

(12) **United States Patent**
Kusleika et al.

(10) **Patent No.:** **US 9,907,643 B2**
(45) **Date of Patent:** ***Mar. 6, 2018**

(54) **SYSTEMS FOR ATTAINING A
PREDETERMINED POROSITY OF A
VASCULAR DEVICE**

(58) **Field of Classification Search**
CPC A61F 2/07; A61F 2/82; A61F 2/86; A61F
2/90; A61F 2/91; A61F 2/958;
(Continued)

(71) Applicant: **COVIDIEN LP**, Mansfield, MA (US)

(56) **References Cited**

(72) Inventors: **Rich Kusleika**, Excelsior, MN (US);
Michael Losordo, San Juan Capistrano,
CA (US)

U.S. PATENT DOCUMENTS

(73) Assignee: **COVIDIEN LP**, Mansfield, MA (US)

2,919,467 A 1/1960 Mercer
4,321,711 A 3/1982 Mano
(Continued)

(*) Notice: Subject to any disclaimer, the term of this
patent is extended or adjusted under 35
U.S.C. 154(b) by 178 days.

This patent is subject to a terminal dis-
claimer.

FOREIGN PATENT DOCUMENTS

CN 101472537 A 7/2009
EP 855170 A2 7/1998
(Continued)

(21) Appl. No.: **14/833,768**

OTHER PUBLICATIONS

(22) Filed: **Aug. 24, 2015**

Benndorf, et al. Treatment of a Ruptured Dissecting Vertebral Artery
Aneurysm with Double Stent Placement: Case Report AJNR Am J
Neuroradiol, Nov.-Dec. 2001, vol. 22, pp. 1844-1848.

(65) **Prior Publication Data**

US 2015/0359646 A1 Dec. 17, 2015

(Continued)

Related U.S. Application Data

Primary Examiner — Ryan J Severson

(63) Continuation of application No. 13/826,971, filed on
Mar. 14, 2013, now Pat. No. 9,114,001.

(74) *Attorney, Agent, or Firm* — Fortem IP LLP; Mary
Fox

(Continued)

(57) **ABSTRACT**

(51) **Int. Cl.**
A61F 2/90 (2013.01)
A61F 2/07 (2013.01)
(Continued)

A system for treating a patient is provided that includes an
expandable vascular device having a body having a sub-
stantially uniform porosity that is adapted to change by
adjusting an axial length of the body. The system also
includes an expanding member positioned within a central
lumen of the device, the expanding member configured to
engage the body, as the body is radially expanded from a
collapsed configuration, and to reduce a porosity of the body
within a body region more than the body porosity is reduced
outside the region.

(52) **U.S. Cl.**
CPC **A61F 2/07** (2013.01); **A61F 2/844**
(2013.01); **A61F 2/90** (2013.01); **A61F 2/958**
(2013.01);
(Continued)

20 Claims, 11 Drawing Sheets

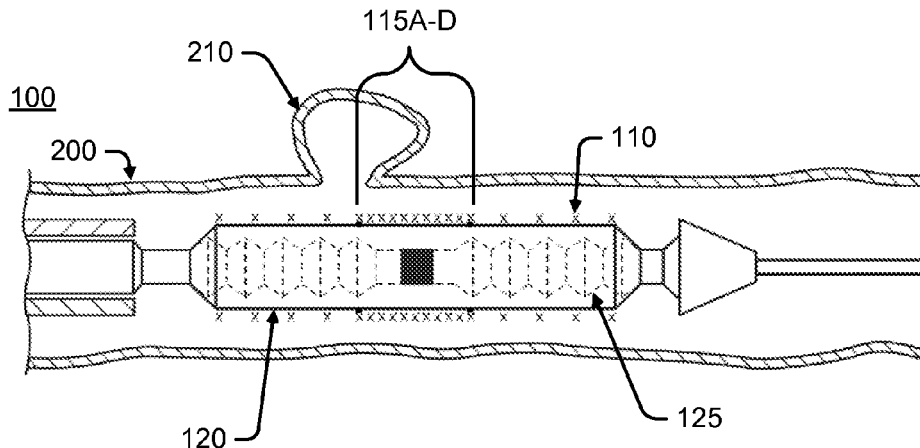

Related U.S. Application Data

(60) Provisional application No. 61/720,154, filed on Oct. 30, 2012.

(51) **Int. Cl.**

A61F 2/958 (2013.01)
A61F 2/844 (2013.01)
A61F 2/82 (2013.01)

(52) **U.S. Cl.**

CPC ... *A61F 2002/823* (2013.01); *A61F 2220/005* (2013.01); *A61F 2220/0008* (2013.01); *A61F 2250/0007* (2013.01); *A61F 2250/0012* (2013.01); *A61F 2250/0018* (2013.01); *A61F 2250/0023* (2013.01); *A61F 2250/0029* (2013.01); *A61F 2250/0039* (2013.01); *A61F 2250/0048* (2013.01)

(58) **Field of Classification Search**

CPC *A61F 2002/075*; *A61F 2002/823*; *A61F 2002/9522*; *A61F 2002/9583*; *A61F 2250/0007*; *A61F 2250/0023*; *A61F 2250/0024*

See application file for complete search history.

(56)

References Cited

U.S. PATENT DOCUMENTS

4,503,569 A 3/1985 Dotter
 4,512,338 A 4/1985 Balko et al.
 4,538,622 A 9/1985 Samson et al.
 4,572,186 A 2/1986 Gould et al.
 4,580,568 A 4/1986 Gianturco
 4,655,771 A 4/1987 Wallsten
 4,681,110 A 7/1987 Wiktor
 4,733,665 A 3/1988 Palmaz
 4,743,251 A 5/1988 Barra
 4,768,507 A 9/1988 Fischell et al.
 4,776,337 A 10/1988 Palmaz
 4,856,516 A 8/1989 Hillstead
 4,954,126 A 9/1990 Wallsten
 5,011,488 A 4/1991 Ginsburg
 5,035,706 A 7/1991 Giantureo et al.
 5,041,126 A 8/1991 Gianturco
 5,061,275 A 10/1991 Wallsten et al.
 5,108,416 A 4/1992 Ryan et al.
 5,160,341 A 11/1992 Brenneman et al.
 5,180,368 A 1/1993 Garrison
 5,192,297 A 3/1993 Hull
 5,197,978 A 3/1993 Hess
 5,201,757 A 4/1993 Heyn et al.
 5,209,731 A 5/1993 Sterman et al.
 5,242,399 A 9/1993 Lau et al.
 5,246,420 A 9/1993 Kraus et al.
 5,246,445 A 9/1993 Yachia et al.
 5,330,500 A 7/1994 Song
 5,344,426 A 9/1994 Lau et al.
 5,360,443 A 11/1994 Barone et al.
 5,382,259 A 1/1995 Phelps et al.
 5,401,257 A 3/1995 Chevalier, Jr. et al.
 5,405,377 A 4/1995 Cragg
 5,405,380 A 4/1995 Gianotti et al.
 5,415,637 A 5/1995 Khosravi
 5,421,826 A 6/1995 Crocker et al.
 5,423,849 A 6/1995 Engelson et al.
 5,449,372 A 9/1995 Schmaltz et al.
 5,458,615 A 10/1995 Klemm et al.
 5,476,505 A 12/1995 Limon
 5,480,423 A 1/1996 Ravenscroft et al.
 5,484,444 A 1/1996 Braunschweiler
 5,489,295 A 2/1996 Piplani et al.
 5,507,767 A 4/1996 Maeda et al.
 5,507,768 A 4/1996 Lau et al.
 5,522,822 A 6/1996 Phelps et al.

5,534,007 A 7/1996 St. Germain et al.
 5,545,208 A 8/1996 Wolff et al.
 5,546,880 A 8/1996 Ronyak et al.
 5,549,662 A 8/1996 Fordenbacher
 5,562,641 A 10/1996 Flomenblit et al.
 5,562,728 A 10/1996 Lazarus et al.
 5,591,225 A 1/1997 Okuda
 5,599,291 A 2/1997 Balbierz et al.
 5,601,593 A 2/1997 Freitag
 5,607,466 A 3/1997 Imbert et al.
 5,609,625 A 3/1997 Piplani et al.
 5,626,602 A 5/1997 Gianotti et al.
 5,628,783 A 5/1997 Quiachon et al.
 5,628,788 A 5/1997 Pinchuk
 5,632,771 A 5/1997 Boatman et al.
 5,632,772 A 5/1997 Alcime et al.
 5,636,641 A 6/1997 Fariabi
 5,637,113 A 6/1997 Tartaglia et al.
 5,639,278 A 6/1997 Dereume et al.
 5,645,559 A 7/1997 Hachtman et al.
 D381,932 S 8/1997 Walshe et al.
 5,667,522 A 9/1997 Flomenblit et al.
 5,674,276 A 10/1997 Andersen et al.
 5,683,451 A 11/1997 Lenker et al.
 5,690,120 A 11/1997 Jacobsen
 5,690,644 A 11/1997 Yurek et al.
 5,695,499 A 12/1997 Helgerson et al.
 5,700,269 A 12/1997 Pinchuk et al.
 5,702,418 A 12/1997 Ravenscroft
 5,709,702 A 1/1998 Cogita
 5,709,703 A 1/1998 Lukic et al.
 5,718,159 A 2/1998 Thompson
 5,725,570 A 3/1998 Heath
 5,733,327 A 3/1998 Igaki et al.
 5,735,859 A 4/1998 Fischell et al.
 5,741,325 A 4/1998 Chaikof et al.
 5,741,333 A 4/1998 Frid
 5,746,765 A 5/1998 Kleshinski et al.
 5,749,883 A 5/1998 Halpern
 5,749,920 A 5/1998 Quiachon et al.
 5,769,884 A 6/1998 Solovay
 5,769,885 A 6/1998 Quiachon et al.
 5,776,099 A 7/1998 Tremulis
 5,776,142 A 7/1998 Gunderson
 5,782,909 A 7/1998 Quiachon et al.
 5,797,952 A 8/1998 Klein
 5,800,518 A 9/1998 Piplani et al.
 5,810,837 A 9/1998 Hofmann et al.
 5,817,102 A 10/1998 Johnson et al.
 5,817,105 A 10/1998 Van Der Brug
 5,824,039 A 10/1998 Piplani et al.
 5,824,041 A 10/1998 Lenker et al.
 5,824,042 A 10/1998 Lombardi et al.
 5,824,044 A 10/1998 Quiachon et al.
 5,824,058 A 10/1998 Ravenscroft et al.
 5,830,229 A 11/1998 Konya et al.
 5,833,632 A 11/1998 Jacobsen et al.
 5,836,868 A 11/1998 Ressemann et al.
 5,843,168 A 12/1998 Dang
 5,868,754 A 2/1999 Levine et al.
 5,876,419 A 3/1999 Carpenter et al.
 5,876,445 A 3/1999 Andersen
 5,888,201 A 3/1999 Stinson et al.
 5,902,266 A 5/1999 Leone et al.
 5,902,317 A 5/1999 Kleshinski et al.
 5,906,640 A 5/1999 Penn et al.
 5,911,717 A 6/1999 Jacobsen et al.
 5,916,194 A 6/1999 Jacobsen et al.
 5,919,204 A 7/1999 Lukic et al.
 5,928,260 A 7/1999 Chin et al.
 5,944,728 A 8/1999 Bates
 5,951,599 A 9/1999 McCrory
 5,957,973 A 9/1999 Quiachon et al.
 5,957,974 A 9/1999 Thompson et al.
 5,964,797 A 10/1999 Ho
 5,980,530 A 11/1999 Willard
 5,980,533 A 11/1999 Holman
 5,984,957 A 11/1999 Laptewicz, Jr. et al.
 6,012,277 A 1/2000 Prins et al.

(56)

References Cited

U.S. PATENT DOCUMENTS

6,014,919	A	1/2000	Jacobsen et al.	6,322,587	B1	11/2001	Quiachon et al.
6,015,432	A	1/2000	Rakos et al.	6,325,826	B1	12/2001	Vardi et al.
6,017,319	A	1/2000	Jacobsen et al.	6,334,871	B1	1/2002	Dor et al.
6,019,778	A	2/2000	Wilson et al.	6,336,938	B1	1/2002	Kavteladze et al.
6,019,786	A	2/2000	Thompson	6,340,367	B1	1/2002	Stinson et al.
6,022,369	A	2/2000	Jacobsen et al.	6,340,368	B1	1/2002	Verbeck
6,024,754	A	2/2000	Engelson	6,342,068	B1	1/2002	Thompson
6,024,763	A	2/2000	Lenker et al.	6,344,041	B1	2/2002	Kupiecki et al.
6,027,516	A	2/2000	Kolobow et al.	6,348,063	B1	2/2002	Yassour et al.
6,033,436	A	3/2000	Steinke et al.	6,350,199	B1	2/2002	Williams et al.
6,039,721	A	3/2000	Johnson	6,350,278	B1	2/2002	Lenker et al.
6,039,758	A	3/2000	Quiachon et al.	6,355,051	B1	3/2002	Sisskind et al.
6,042,589	A	3/2000	Marianne	6,355,061	B1	3/2002	Quiachon
6,051,021	A	4/2000	Frid	6,364,895	B1	4/2002	Greenhalgh
6,056,993	A	5/2000	Leidner et al.	6,368,339	B1	4/2002	Amplatz
6,063,111	A	5/2000	Hieshima et al.	6,368,344	B1	4/2002	Fitz
6,074,407	A	6/2000	Levine et al.	6,368,557	B1	4/2002	Piplani et al.
6,077,295	A	6/2000	Limon et al.	6,375,670	B1	4/2002	Greenhalgh
6,080,191	A	6/2000	Summers	6,375,676	B1	4/2002	Cox
6,083,257	A	7/2000	Taylor et al.	6,379,618	B1	4/2002	Piplani et al.
6,093,199	A	7/2000	Brown et al.	6,380,457	B1	4/2002	Yurek et al.
6,096,052	A	8/2000	Callister et al.	6,389,946	B1	5/2002	Frid
6,102,942	A	8/2000	Ahari	6,395,017	B1	5/2002	Dwyer et al.
6,123,712	A	9/2000	Di Caprio et al.	6,395,021	B1	5/2002	Hart et al.
6,126,685	A	10/2000	Lenker et al.	6,395,022	B1	5/2002	Piplani et al.
6,132,459	A	10/2000	Piplani et al.	6,398,802	B1	6/2002	Yee
6,139,543	A	10/2000	Esch et al.	6,409,683	B1	6/2002	Fonseca et al.
6,146,415	A	11/2000	Fitz	6,413,235	B1	7/2002	Parodi
6,149,680	A	11/2000	Shelso et al.	6,416,519	B1	7/2002	VanDusseldorp
6,159,228	A	12/2000	Frid et al.	6,416,536	B1	7/2002	Yee
6,161,399	A	12/2000	Jayaraman	6,419,693	B1	7/2002	Fariabi
6,165,194	A	12/2000	Denardo	6,428,489	B1	8/2002	Jacobsen et al.
6,165,210	A	12/2000	Lau et al.	6,440,088	B1	8/2002	Jacobsen et al.
6,165,213	A	12/2000	Goicoechea et al.	6,443,971	B1	9/2002	Boylan et al.
6,168,592	B1	1/2001	Kupiecki et al.	6,443,979	B1	9/2002	Stalker
6,174,330	B1	1/2001	Stinson	6,454,999	B1	9/2002	Farhangnia et al.
6,183,410	B1	2/2001	Jacobsen et al.	6,468,301	B1	10/2002	Amplatz et al.
6,183,508	B1	2/2001	Stinson et al.	6,477,768	B1	11/2002	Wildner
6,187,013	B1	2/2001	Stoltze et al.	6,478,778	B1	11/2002	Jacobsen et al.
6,193,708	B1	2/2001	Ken et al.	6,482,221	B1	11/2002	Hebert et al.
6,197,046	B1	3/2001	Piplani et al.	6,488,705	B2	12/2002	Schmitt et al.
6,203,569	B1	3/2001	Wijay	6,491,648	B1	12/2002	Cornish et al.
6,206,868	B1	3/2001	Parodi	6,494,895	B2	12/2002	Addis
6,210,400	B1	4/2001	Hebert et al.	6,497,711	B1	12/2002	Plaia et al.
6,210,434	B1	4/2001	Quiachon et al.	6,503,450	B1	1/2003	Afzal
6,210,435	B1	4/2001	Piplani et al.	6,514,261	B1	2/2003	Randall et al.
6,214,038	B1	4/2001	Piplani et al.	6,514,285	B1	2/2003	Pinchasik
6,214,042	B1	4/2001	Jacobsen et al.	6,524,299	B1	2/2003	Tran et al.
6,221,102	B1	4/2001	Baker et al.	6,527,763	B2	3/2003	Esch et al.
6,224,609	B1	5/2001	Ressemann et al.	6,533,811	B1	3/2003	Ryan et al.
6,224,829	B1	5/2001	Piplani et al.	6,540,778	B1	4/2003	Quiachon et al.
6,231,598	B1	5/2001	Berry et al.	6,547,779	B2	4/2003	Levine
6,235,050	B1	5/2001	Quiachon et al.	6,551,352	B2	4/2003	Clerc et al.
6,241,759	B1	6/2001	Piplani et al.	6,572,646	B1	6/2003	Boylan et al.
6,245,087	B1	6/2001	Addis	6,576,006	B2	6/2003	Limon et al.
6,245,103	B1	6/2001	Stinson	6,582,460	B1	6/2003	Cryer
6,251,132	B1	6/2001	Ravenscroft et al.	6,582,461	B1	6/2003	Burmeister et al.
6,258,115	B1	7/2001	Dubrul	6,589,273	B1	7/2003	McDermott
6,260,458	B1	7/2001	Jacobsen et al.	6,592,616	B1	7/2003	Stack et al.
6,261,305	B1	7/2001	Marotta et al.	6,595,989	B1	7/2003	Scheer
6,261,316	B1	7/2001	Shaolian et al.	6,602,271	B2	8/2003	Adams et al.
6,264,671	B1	7/2001	Stack	6,602,280	B2	8/2003	Chobotov
6,264,689	B1	7/2001	Colgan et al.	6,605,110	B2	8/2003	Harrison
6,270,523	B1	8/2001	Herweck et al.	6,613,075	B1	9/2003	Healy et al.
6,280,465	B1	8/2001	Cryer	6,613,078	B1	9/2003	Barone
6,283,991	B1	9/2001	Cox et al.	6,622,604	B1	9/2003	Chouinard et al.
6,287,331	B1	9/2001	Heath	6,623,518	B2	9/2003	Thompson et al.
6,287,333	B1	9/2001	Appling et al.	6,635,068	B1	10/2003	Dubrul et al.
6,290,721	B1	9/2001	Heath	6,638,243	B2	10/2003	Kupiecki
6,299,636	B1	10/2001	Schmitt et al.	6,645,240	B2	11/2003	Yee
6,302,810	B2	10/2001	Yokota	6,646,218	B1	11/2003	Campbell et al.
6,302,893	B1	10/2001	Limon et al.	6,652,508	B2	11/2003	Griffin
6,309,353	B1	10/2001	Cheng et al.	6,652,574	B1	11/2003	Jayaraman
6,322,576	B1	11/2001	Wallace et al.	6,656,212	B2	12/2003	Ravenscroft et al.
6,322,586	B1	11/2001	Monroe et al.	6,656,218	B1	12/2003	Denardo et al.
				6,660,024	B1	12/2003	Flaherty
				6,660,032	B2	12/2003	Klumb et al.
				6,663,666	B1	12/2003	Quiachon et al.
				6,666,881	B1	12/2003	Richter et al.

(56)

References Cited

U.S. PATENT DOCUMENTS

6,669,719	B2	12/2003	Wallace	7,201,769	B2	4/2007	Jones et al.
6,673,089	B1	1/2004	Yassour et al.	7,211,109	B2	5/2007	Thompson
6,673,100	B2	1/2004	Diaz et al.	7,213,495	B2	5/2007	McCullagh et al.
6,679,893	B1	1/2004	Tran	7,220,271	B2	5/2007	Clubb et al.
6,682,557	B1	1/2004	Quiachon et al.	7,235,096	B1	6/2007	Van Tassel et al.
6,685,735	B1	2/2004	Ahari	7,264,632	B2	9/2007	Wright et al.
6,689,120	B1	2/2004	Gerdts	7,275,471	B2	10/2007	Nishri et al.
6,689,162	B1	2/2004	Thompson	7,279,005	B2	10/2007	Stinson
6,699,274	B2	3/2004	Stinson	7,279,208	B1	10/2007	Goffena et al.
6,702,843	B1	3/2004	Brown et al.	7,294,137	B2	11/2007	Riveili, Jr. et al.
6,709,454	B1	3/2004	Cox et al.	7,294,146	B2	11/2007	Chew et al.
6,712,834	B2	3/2004	Yassour et al.	7,300,456	B2	11/2007	Andreas et al.
6,726,700	B1	4/2004	Levine	7,300,460	B2	11/2007	Levine et al.
6,733,519	B2	5/2004	Lashinski et al.	7,306,624	B2	12/2007	Yodfat et al.
6,740,105	B2	5/2004	Yodfat et al.	7,309,351	B2	12/2007	Escamilla et al.
6,740,112	B2	5/2004	Yodfat et al.	7,311,031	B2	12/2007	McCullagh et al.
6,743,219	B1	6/2004	Dwyer et al.	7,320,702	B2	1/2008	Hammersmark et al.
6,755,855	B2	6/2004	Yurek et al.	7,323,001	B2	1/2008	Clubb et al.
6,758,885	B2	7/2004	Leffel et al.	7,331,973	B2	2/2008	Gesswein et al.
6,767,361	B2	7/2004	Quiachon et al.	7,331,976	B2	2/2008	McGuckin, Jr. et al.
6,773,446	B1	8/2004	Dwyer et al.	7,331,985	B2	2/2008	Thompson et al.
6,793,667	B2	9/2004	Hebert et al.	7,338,518	B2	3/2008	Chobotov
6,814,746	B2	11/2004	Thompson et al.	7,438,712	B2	10/2008	Chouinard
6,814,748	B1	11/2004	Baker et al.	7,462,192	B2	12/2008	Norton et al.
6,818,006	B2	11/2004	Douk et al.	7,468,070	B2	12/2008	Henry et al.
6,833,003	B2	12/2004	Jones et al.	7,470,282	B2	12/2008	Shelso
6,849,084	B2	2/2005	Rabkin et al.	7,473,271	B2	1/2009	Gunderson
6,858,034	B1	2/2005	Hijlkema et al.	7,491,224	B2	2/2009	Cox et al.
6,860,893	B2	3/2005	Wallace et al.	7,520,893	B2	4/2009	Rivelli, Jr.
6,860,898	B2	3/2005	Stack et al.	RE40,816	E	6/2009	Taylor et al.
6,860,899	B1	3/2005	Rivelli, Jr.	7,572,288	B2	8/2009	Cox
6,860,900	B2	3/2005	Clerc et al.	7,572,290	B2	8/2009	Yodfat et al.
6,860,901	B1	3/2005	Baker et al.	7,588,597	B2	9/2009	Frid
6,866,677	B2	3/2005	Douk et al.	7,695,507	B2	4/2010	Rivelli, Jr. et al.
6,866,679	B2	3/2005	Kusleika	7,763,011	B2	7/2010	Ortiz et al.
6,866,680	B2	3/2005	Yassour et al.	7,771,463	B2	8/2010	Ton et al.
6,881,221	B2	4/2005	Golds	7,854,760	B2	12/2010	Molaei et al.
6,887,267	B2	5/2005	Dworschak et al.	7,901,447	B2	3/2011	Molaei et al.
6,890,337	B2	5/2005	Feeser et al.	7,942,925	B2	5/2011	Yodfat et al.
6,893,451	B2	5/2005	Cano et al.	8,007,529	B2	8/2011	Yan
6,918,921	B2	7/2005	Brady et al.	8,092,486	B2	1/2012	Berrada et al.
6,932,837	B2	8/2005	Amplatz et al.	8,092,508	B2	1/2012	Leynov et al.
6,936,055	B1	8/2005	Ken et al.	8,192,484	B2	6/2012	Frid
6,955,685	B2	10/2005	Escamilla et al.	8,382,825	B2	2/2013	Garcia et al.
6,960,227	B2	11/2005	Jones et al.	8,394,119	B2	3/2013	Zaver et al.
6,964,670	B1	11/2005	Shah et al.	8,398,701	B2	3/2013	Berez et al.
6,964,672	B2	11/2005	Brady et al.	8,617,234	B2	12/2013	Garcia et al.
6,969,396	B2	11/2005	Krolík et al.	8,623,067	B2	1/2014	Berez et al.
6,976,991	B2	12/2005	Hebert et al.	8,628,564	B2	1/2014	Berez et al.
6,989,024	B2	1/2006	Hebert et al.	8,764,817	B2	7/2014	Sheldon
6,994,721	B2	2/2006	Israel	8,801,772	B2	8/2014	Shobayashi et al.
7,001,422	B2	2/2006	Escamilla et al.	8,979,918	B2	3/2015	Murayama
7,004,962	B2	2/2006	Stinson	9,050,205	B2	6/2015	Berez et al.
7,004,964	B2	2/2006	Thompson et al.	9,114,001	B2	8/2015	Kusleika et al.
7,011,675	B2	3/2006	Hemerick et al.	9,125,659	B2	9/2015	Berez et al.
7,037,330	B1	5/2006	Rivelli, Jr. et al.	9,301,831	B2*	4/2016	Kusleika A61F 2/90
7,041,129	B2	5/2006	Rourke et al.	9,452,070	B2*	9/2016	Kusleika A61F 2/852
7,066,951	B2	6/2006	Chobotov	2001/0027338	A1	10/2001	Greenberg
7,069,835	B2	7/2006	Nishri et al.	2001/0044651	A1	11/2001	Steinke et al.
7,074,236	B2	7/2006	Rabkin et al.	2001/0049547	A1	12/2001	Moore
7,093,527	B2	8/2006	Rapaport et al.	2001/0056299	A1	12/2001	Thompson
7,101,392	B2	9/2006	Heath	2002/0004667	A1	1/2002	Adams et al.
7,107,105	B2	9/2006	Bjorklund et al.	2002/0007194	A1	1/2002	Plowiecki
7,118,539	B2	10/2006	Vrba et al.	2002/0029061	A1	3/2002	Amplatz et al.
7,118,594	B2	10/2006	Quiachon et al.	2002/0035396	A1	3/2002	Heath
7,122,050	B2	10/2006	Randall et al.	2002/0062091	A1	5/2002	Jacobsen et al.
7,137,990	B2	11/2006	Hebert et al.	2002/0078808	A1	6/2002	Jacobsen et al.
7,166,125	B1	1/2007	Baker et al.	2002/0082558	A1	6/2002	Samson et al.
7,169,170	B2	1/2007	Widenhouse	2002/0087119	A1	7/2002	Parodi
7,169,172	B2	1/2007	Levine et al.	2002/0111633	A1	8/2002	Stoltze et al.
7,172,617	B2	2/2007	Colgan et al.	2002/0111648	A1	8/2002	Kusleika et al.
7,192,434	B2	3/2007	Anderson et al.	2002/0120323	A1	8/2002	Thompson et al.
7,195,639	B2	3/2007	Quiachon et al.	2002/0138133	A1	9/2002	Lenz et al.
7,195,648	B2	3/2007	Jones et al.	2002/0143361	A1	10/2002	Douk et al.
7,201,768	B2	4/2007	Diaz et al.	2002/0143384	A1	10/2002	Ozasa
				2002/0169473	A1	11/2002	Sepetka et al.
				2002/0169474	A1	11/2002	Kusleika et al.
				2002/0173839	A1	11/2002	Leopold et al.
				2002/0188314	A1	12/2002	Anderson et al.

(56)

References Cited

U.S. PATENT DOCUMENTS

2002/0193864	A1	12/2002	Khosravi et al.	2007/0021816	A1	1/2007	Rudin
2003/0009215	A1	1/2003	Mayer	2007/0043419	A1	2/2007	Nikolchev et al.
2003/0023299	A1	1/2003	Amplatz et al.	2007/0055365	A1	3/2007	Greenberg et al.
2003/0069522	A1	4/2003	Jacobsen et al.	2007/0060994	A1	3/2007	Gobran et al.
2003/0100945	A1	5/2003	Yodfat et al.	2007/0073379	A1	3/2007	Chang
2003/0130684	A1	7/2003	Brady et al.	2007/0077347	A1	4/2007	Richter
2003/0135258	A1	7/2003	Andreas et al.	2007/0100321	A1	5/2007	Rudakov et al.
2003/0163155	A1	8/2003	Haverkost et al.	2007/0100414	A1	5/2007	Licata
2003/0163156	A1	8/2003	Hebert et al.	2007/0100430	A1	5/2007	Rudakov et al.
2003/0176884	A1	9/2003	Berrada et al.	2007/0112415	A1	5/2007	Bartlett
2003/0187495	A1	10/2003	Cully et al.	2007/0119295	A1	5/2007	McCullagh
2003/0212429	A1	11/2003	Keegan	2007/0123969	A1	5/2007	Gianotti
2003/0212430	A1	11/2003	Bose et al.	2007/0162104	A1	7/2007	Frid
2004/0024416	A1	2/2004	Yodfat et al.	2007/0167980	A1	7/2007	Figulla et al.
2004/0030265	A1	2/2004	Murayama et al.	2007/0198076	A1	8/2007	Hebert et al.
2004/0044395	A1	3/2004	Nelson	2007/0203559	A1	8/2007	Freudenthal et al.
2004/0073300	A1	4/2004	Chouinard et al.	2007/0203563	A1	8/2007	Hebert et al.
2004/0088037	A1	5/2004	Nachreiner et al.	2007/0208367	A1	9/2007	Fiorella et al.
2004/0093010	A1	5/2004	Gesswein et al.	2007/0208373	A1	9/2007	Zaver et al.
2004/0098099	A1	5/2004	McCullagh et al.	2007/0208376	A1	9/2007	Meng
2004/0133223	A1	7/2004	Weber	2007/0208415	A1	9/2007	Grotheim et al.
2004/0153117	A1	8/2004	Clubb et al.	2007/0219619	A1	9/2007	Dieck et al.
2004/0162606	A1	8/2004	Thompson	2007/0225760	A1	9/2007	Moszner et al.
2004/0172055	A1	9/2004	Huter et al.	2007/0233175	A1	10/2007	Zaver et al.
2004/0186368	A1	9/2004	Ramzpoor et al.	2007/0239261	A1	10/2007	Bose et al.
2004/0193178	A1	9/2004	Nikolchev	2007/0255386	A1	11/2007	Tenne
2004/0193179	A1	9/2004	Nikolchev	2007/0255388	A1	11/2007	Rudakov et al.
2004/0193208	A1	9/2004	Talpade et al.	2007/0280850	A1	12/2007	Carlson
2004/0199243	A1	10/2004	Yodfat	2007/0299500	A1	12/2007	Hebert et al.
2004/0210235	A1	10/2004	Deshmukh et al.	2007/0299501	A1	12/2007	Hebert et al.
2004/0215332	A1	10/2004	Frid	2007/0299502	A1	12/2007	Hebert et al.
2004/0220585	A1	11/2004	Nikolchev	2008/0015673	A1	1/2008	Chuter
2004/0220608	A1	11/2004	D'Aquanni et al.	2008/0033341	A1	2/2008	Grad
2004/0220663	A1	11/2004	Rivelli	2008/0033526	A1	2/2008	Atladottir et al.
2004/0254628	A1	12/2004	Nazzaro et al.	2008/0039930	A1	2/2008	Jones et al.
2004/0260331	A1	12/2004	D'Aquanni et al.	2008/0039933	A1	2/2008	Yodfat
2005/0004595	A1	1/2005	Boyle et al.	2008/0071351	A1	3/2008	Flanagan et al.
2005/0021075	A1	1/2005	Bonnette et al.	2008/0082154	A1	4/2008	Tseng et al.
2005/0033407	A1	2/2005	Weber et al.	2008/0114391	A1	5/2008	Dieck et al.
2005/0038447	A1	2/2005	Huffmaster	2008/0119943	A1	5/2008	Armstrong et al.
2005/0051243	A1	3/2005	Forbes Jones et al.	2008/0125855	A1	5/2008	Henkes et al.
2005/0055047	A1	3/2005	Greenhalgh	2008/0208320	A1	8/2008	Tan-Malecki et al.
2005/0059889	A1	3/2005	Mayer	2008/0221666	A1	9/2008	Licata et al.
2005/0060017	A1	3/2005	Fischell et al.	2008/0221670	A1	9/2008	Clerc et al.
2005/0090888	A1	4/2005	Hines et al.	2008/0221671	A1	9/2008	Chouinard et al.
2005/0101989	A1	5/2005	Cully et al.	2008/0255654	A1	10/2008	Hebert et al.
2005/0137680	A1	6/2005	Ortiz et al.	2008/0255655	A1	10/2008	Kusleika et al.
2005/0149111	A1	7/2005	Kanazawa et al.	2008/0262590	A1	10/2008	Murray
2005/0165441	A1	7/2005	McGuckin et al.	2008/0269774	A1	10/2008	Garcia et al.
2005/0177186	A1	8/2005	Cully et al.	2008/0275497	A1	11/2008	Palmer et al.
2005/0192620	A1	9/2005	Cully et al.	2008/0275498	A1	11/2008	Palmer et al.
2005/0197689	A1	9/2005	Molaei	2008/0294104	A1	11/2008	Mawad
2005/0209672	A1	9/2005	George et al.	2008/0300667	A1	12/2008	Hebert et al.
2005/0209678	A1	9/2005	Henkes et al.	2008/0300668	A1	12/2008	Bonsignore
2005/0246010	A1	11/2005	Alexander et al.	2008/0300673	A1	12/2008	Clerc et al.
2005/0267568	A1	12/2005	Berez et al.	2009/0024202	A1	1/2009	Dave et al.
2005/0283220	A1	12/2005	Gobran et al.	2009/0024205	A1	1/2009	Hebert et al.
2005/0288764	A1	12/2005	Snow	2009/0030496	A1	1/2009	Kaufmann
2005/0288766	A1	12/2005	Plain et al.	2009/0030497	A1	1/2009	Metcalf et al.
2006/0020324	A1	1/2006	Schmid et al.	2009/0054981	A1	2/2009	Frid et al.
2006/0036309	A1	2/2006	Hebert et al.	2009/0099643	A1	4/2009	Hyodoh et al.
2006/0089703	A1	4/2006	Escamilla et al.	2009/0105802	A1	4/2009	Henry et al.
2006/0095213	A1	5/2006	Escamilla et al.	2009/0105803	A1	4/2009	Shelso
2006/0111771	A1	5/2006	Ton et al.	2009/0125093	A1	5/2009	Hansen
2006/0116713	A1	6/2006	Sepetka et al.	2009/0192536	A1	7/2009	Berez et al.
2006/0116750	A1	6/2006	Hebert et al.	2009/0192587	A1	7/2009	Frid
2006/0184238	A1	8/2006	Kaufmann et al.	2009/0198318	A1	8/2009	Berez et al.
2006/0195118	A1	8/2006	Richardson	2009/0216307	A1	8/2009	Kaufmann et al.
2006/0206148	A1	9/2006	Khairkhahan et al.	2009/0222035	A1	9/2009	Schneiderman
2006/0206200	A1	9/2006	Garcia et al.	2009/0270974	A1	10/2009	Berez et al.
2006/0206201	A1	9/2006	Garcia et al.	2009/0287241	A1	11/2009	Berez et al.
2006/0212127	A1	9/2006	Karabey et al.	2009/0287288	A1	11/2009	Berez et al.
2006/0271149	A1	11/2006	Berez et al.	2009/0288000	A1	11/2009	McPherson
2006/0271153	A1	11/2006	Garcia et al.	2009/0292348	A1	11/2009	Berez et al.
2006/0276910	A1	12/2006	Weber	2009/0318947	A1	12/2009	Garcia et al.
				2009/0319017	A1	12/2009	Berez et al.
				2010/0010624	A1	1/2010	Berez et al.
				2010/0042200	A1	2/2010	Richter et al.
				2010/0061604	A1	3/2010	Nahm et al.

(56)

References Cited

U.S. PATENT DOCUMENTS

2010/0063531 A1 3/2010 Rudakov et al.
 2010/0070024 A1 3/2010 Venturelli et al.
 2010/0076317 A1 3/2010 Babic et al.
 2010/0152834 A1 6/2010 Hannes et al.
 2010/0161025 A1 6/2010 Kuppurathanam et al.
 2010/0174269 A1 7/2010 Tompkins et al.
 2010/0174309 A1 7/2010 Fulkerson et al.
 2010/0179583 A1 7/2010 Carpenter et al.
 2010/0179647 A1 7/2010 Carpenter et al.
 2010/0198334 A1 8/2010 Yodfat et al.
 2010/0204779 A1 8/2010 Schuessler et al.
 2010/0211154 A1 8/2010 Murayama
 2010/0222864 A1 9/2010 Rivelli, Jr. et al.
 2010/0241214 A1 9/2010 Holzer et al.
 2010/0256732 A1 10/2010 Shin et al.
 2010/0256733 A1 10/2010 Schuessler
 2010/0280587 A1 11/2010 Ortiz et al.
 2010/0318174 A1 12/2010 Shaolian et al.
 2010/0318178 A1 12/2010 Rapaport et al.
 2011/0016427 A1 1/2011 Douen
 2011/0040372 A1 2/2011 Hansen et al.
 2011/0046718 A1 2/2011 Cattaneo
 2011/0046720 A1 2/2011 Shalev et al.
 2011/0054589 A1 3/2011 Bashiri et al.
 2011/0166592 A1 7/2011 Garcia et al.
 2011/0166637 A1 7/2011 Irwin et al.
 2011/0166639 A1 7/2011 Pulnev et al.
 2011/0179389 A1 7/2011 Douen
 2011/0184451 A1 7/2011 Sahl
 2011/0190862 A1 8/2011 Bashiri et al.
 2011/0245862 A1 10/2011 Dieck et al.
 2011/0270178 A1 11/2011 Fiorella et al.
 2012/0035643 A1 2/2012 Khairkhahan et al.
 2012/0041459 A1 2/2012 Fiorella et al.
 2012/0158124 A1 6/2012 Zaver et al.
 2012/0253454 A1 10/2012 Costello
 2012/0290067 A1 11/2012 Cam
 2012/0316638 A1 12/2012 Grad et al.
 2012/0323309 A1 12/2012 Cattaneo
 2013/0116773 A1 5/2013 Roeder et al.
 2013/0123901 A1 5/2013 Connor et al.
 2013/0138202 A1 5/2013 Paul et al.
 2013/0172975 A1 7/2013 Berez et al.
 2013/0190856 A1 7/2013 von Oepen et al.
 2013/0204347 A1 8/2013 Armstrong et al.
 2013/0211489 A1 8/2013 Makower et al.
 2013/0211497 A1 8/2013 Charlebois et al.
 2013/0274849 A1 10/2013 Zaver et al.
 2014/0018843 A1 1/2014 Berez et al.
 2014/0074149 A1 3/2014 Garcia et al.
 2014/0121744 A1 5/2014 Kusleika
 2014/0121745 A1* 5/2014 Kusleika A61F 2/90
 623/1.11
 2014/0121746 A1 5/2014 Kusleika et al.
 2014/0128957 A1 5/2014 Losordo et al.
 2014/0222130 A1 8/2014 Kusleika
 2014/0316454 A1 10/2014 Zaver et al.
 2014/0336741 A1 11/2014 Connor et al.
 2015/0359646 A1* 12/2015 Kusleika A61F 2/90
 623/1.11
 2017/0000631 A1* 1/2017 Kusleika A61F 2/852

FOREIGN PATENT DOCUMENTS

EP 1683541 A2 7/2006
 EP 1942972 A1 7/2008
 EP 1872742 B1 5/2009
 EP 2 078 512 A1 7/2009
 FR 2556210 B1 4/1988
 JP 10-328216 A 12/1998
 JP 11-506686 6/1999
 JP 11-299901 A 11/1999
 JP 2001-509412 A 7/2001
 JP 2002-253682 A 9/2002

JP 2003-520103 A 7/2003
 JP 2004-049585 A 2/2004
 JP 2005-074230 A 3/2005
 JP 2006-506201 A 2/2006
 JP 2008-502378 A 1/2008
 JP 2008-541832 A 11/2008
 WO WO-88/00813 A1 2/1988
 WO WO-95/009586 A1 4/1995
 WO WO-95/032757 A1 12/1995
 WO WO-98/004211 A1 2/1998
 WO WO-98/47447 A1 10/1998
 WO WO-99/002092 A1 1/1999
 WO WO-99/05977 A1 2/1999
 WO WO-99/049812 A3 12/1999
 WO WO-01/005331 A1 1/2001
 WO WO-01/052771 A1 7/2001
 WO WO-02/005729 1/2002
 WO WO-02/047579 6/2002
 WO WO-02/054988 A3 1/2003
 WO WO-03/007840 A2 1/2003
 WO WO-03/043527 A2 5/2003
 WO WO-03/049600 A2 6/2003
 WO WO-03/057079 A1 7/2003
 WO WO-03/073963 A2 9/2003
 WO WO-2004/087006 A3 11/2004
 WO WO-2005/021061 A2 3/2005
 WO WO-2005/023149 A3 12/2005
 WO WO-2006/034140 A2 3/2006
 WO WO-2006/073745 A2 7/2006
 WO WO-2006/127005 A1 11/2006
 WO WO-2007/122396 A1 11/2007
 WO WO-20081005898 A2 1/2008
 WO WO-2007/139689 A3 9/2008
 WO WO-2007/139699 A3 9/2008
 WO WO-2008/156683 A1 12/2008
 WO WO-2005/115118 A3 7/2009
 WO WO-2009/105710 A1 8/2009
 WO WO-2010/127838 A2 11/2010
 WO WO-2011/023105 A1 3/2011
 WO WO-2011/134663 A2 11/2011

OTHER PUBLICATIONS

Brilstra, et al., Treatment of Intracranial Aneurysms by Embolization with Coils: A Systematic Review, Stroke, Journal of the American Heart Association, 1999, vol. 30, pp. 470-476.
 Ferguson, Gary, Physical Factors in the Initiation, Growth and Rupture of Human Intracranial Saccular Aneurysms, J. Neurosurg, Dec. 1972, vol. 37, pp. 666-667.
 Geremia, et al., Embolization of Experimentally Created Aneurysms with Intravascular Stent Devices, ANJR American Journal of Neuroradiology, Aug. 1994, vol. 15, pp. 1223-1231.
 Geremia, et al., Occlusion of Experimentally Created Fusiform Aneurysms with Porous Metallic Stents, ANJR Am J Neuroradiol, Apr. 2000, Issue 21, pp. 739-745.
 Lanzino, et al., Efficacy and Current Limitations of Intravascular Stents for Intracranial Internal Carotid, Vertebral, and Basilar Artery Aneurysms, Journal of Neurosurgery, Oct. 1999, vol. 91, Issue 4, pp. 538-546.
 Lieber, et al., Alteration of Hemodynamics in Aneurysm Models by Stenting: Influence of Stent Porosity, Ann of Biomedical Eng., 1997, vol. 25, pp. 460-469, Buffalo, NY.
 Lieber, et al., The Physics of Endoluminal Stenting in the Treatment of Cerebrovascular Aneurysms, Neurological Research, 2002, Vcol 24, Issue Supplement 1, pp. S32-S42.
 Moss, et al., Vascular Occlusion with a Balloon-Expandable Stent Occluder, Radiology, May 1994, vol. 191, Issue 2, pp. 483-486.
 Pereira, Edgard, History of Endovascular Aneurysm Occlusion, Management of Cerebral Aneurysms, 2004, pp. 11-26.
 Qureshi, Adnan, Endovascular Treatment of Cerebrovascular Diseases and Intracranial Neoplasms, The Lancet, Mar. 2004, vol. 363, pp. 804-81390.
 Steiger, Pathophysiology of Development and Rupture of Cerebral Aneurysms, Acta Neurochirurgica, Mar. 1990, vol. Supplementum 48, Pages in 62 pages.

(56)

References Cited

OTHER PUBLICATIONS

Tenaglia, et al., Ultrasound Guide Wire-Directed Stent Deployment, Duke University Medical Center, Department of Medicine, 1993 USA.

Yu, et al., A Steady Flow Analysis on the Stented and Non-Stented Sidewall Aneurysm Models, Medical Engineering and Physics, Apr. 1999, Issue 21, pp. 133-141.

U.S. Appl. No. 14/791,876, filed Jul. 6, 2015.

U.S. Appl. No. 14/714,619, filed May 18, 2015.

* cited by examiner

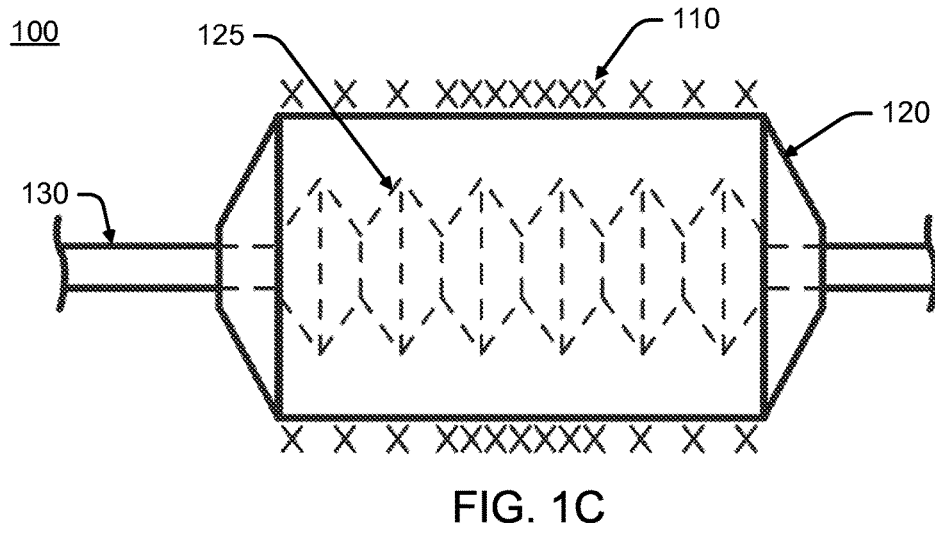
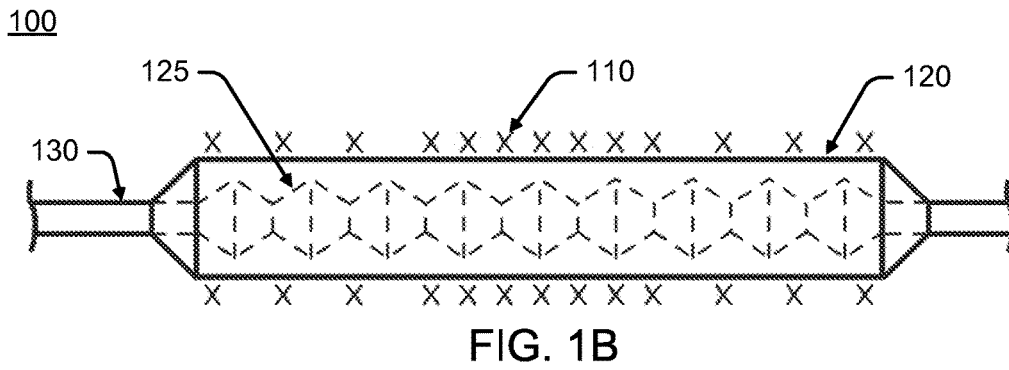
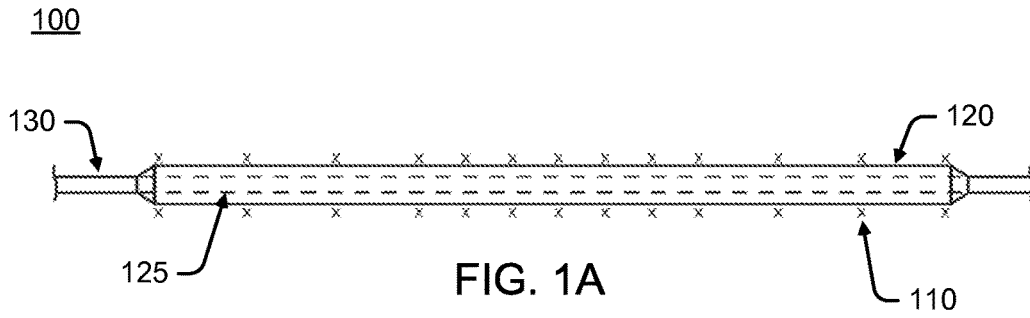

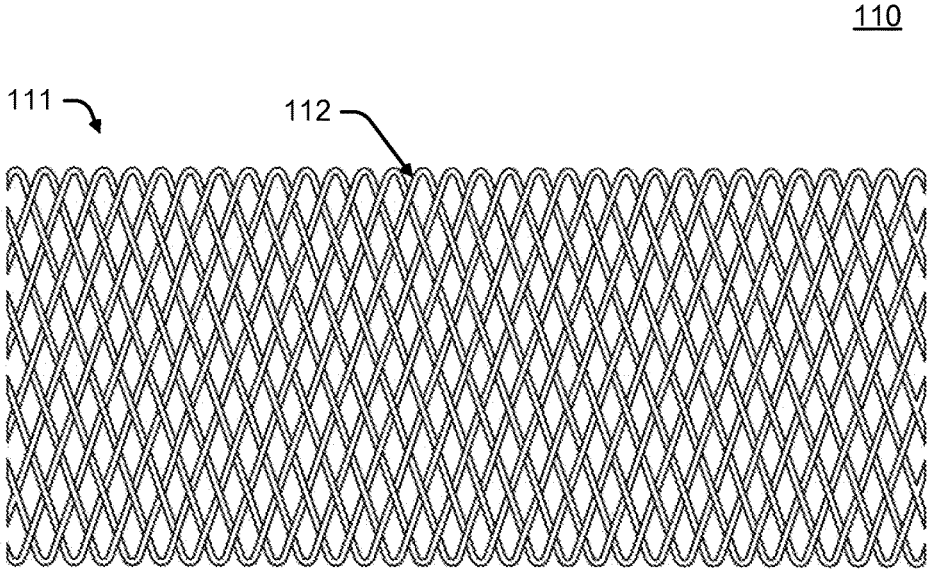
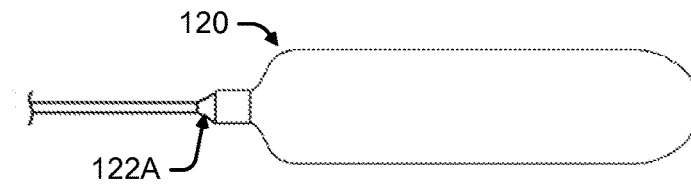
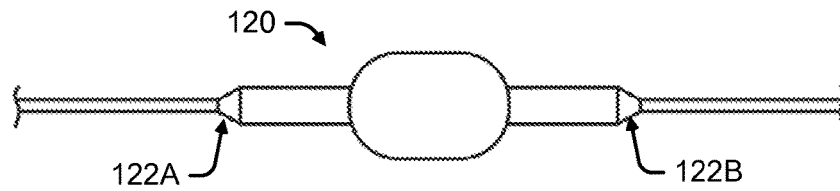
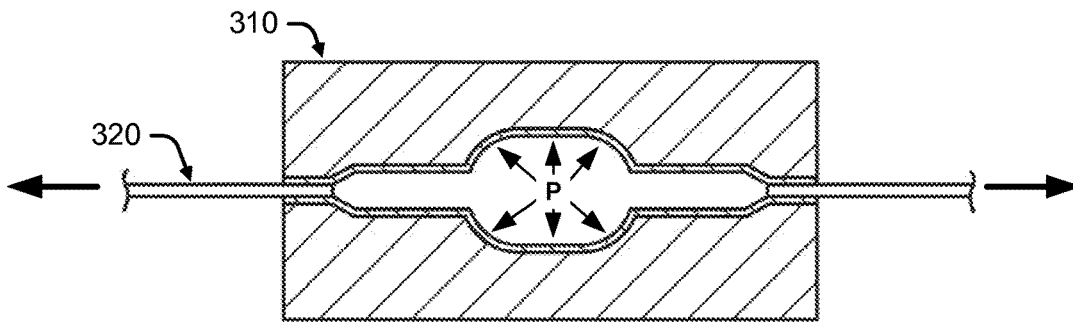
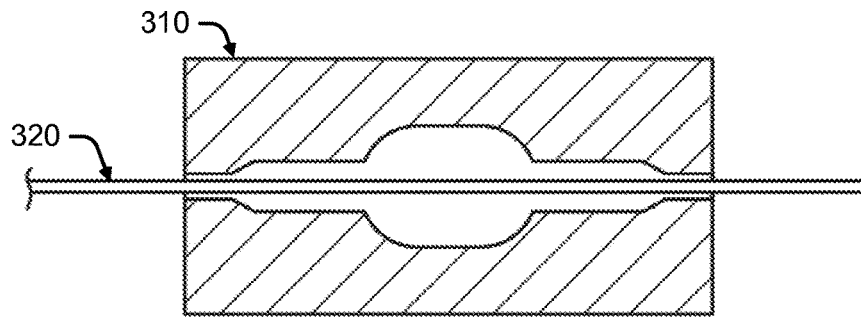
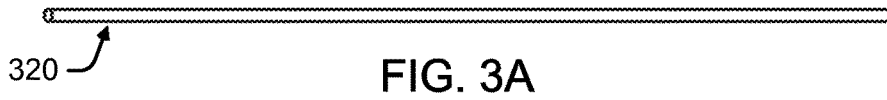

FIG. 2



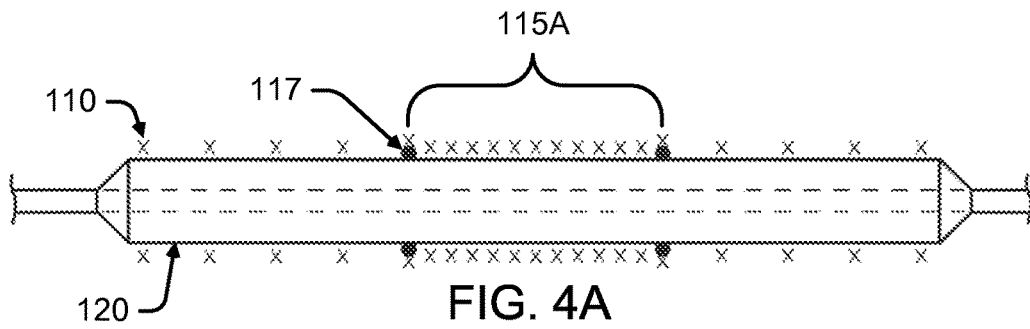

FIG. 4A

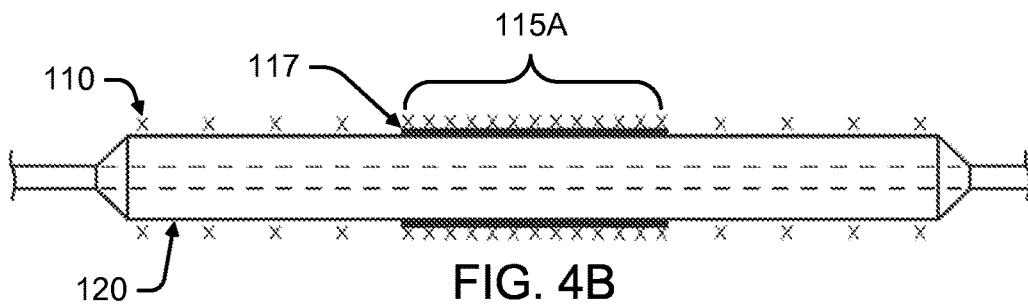

FIG. 4B

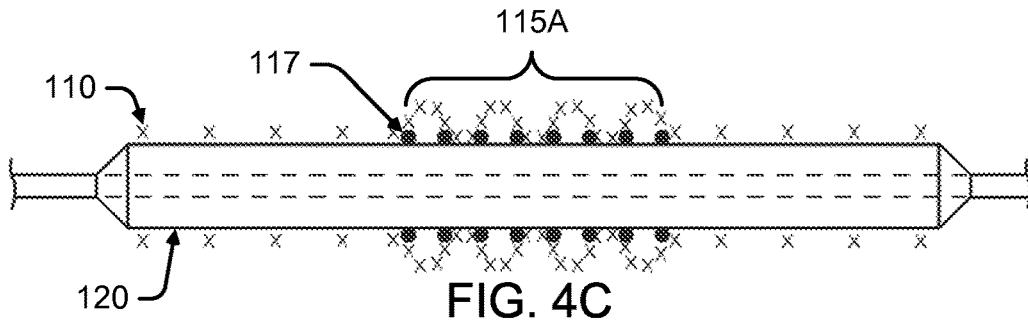

FIG. 4C

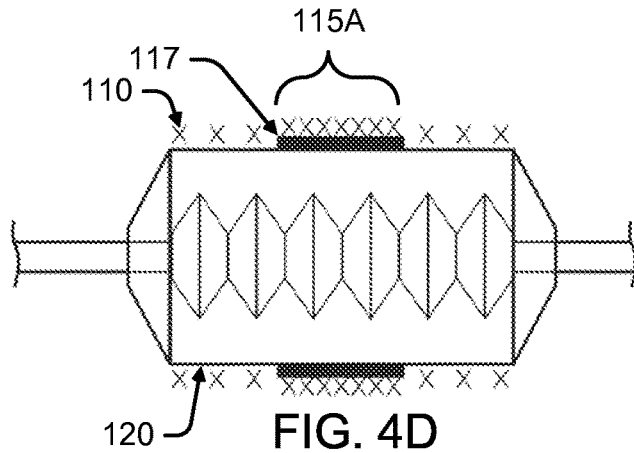

FIG. 4D

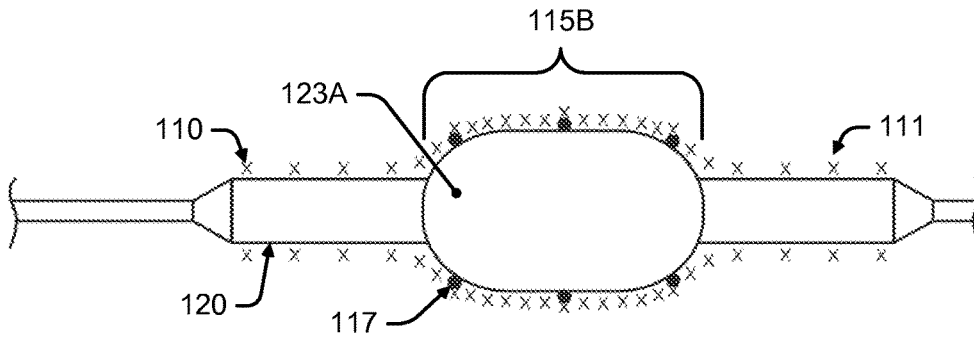

FIG. 5A

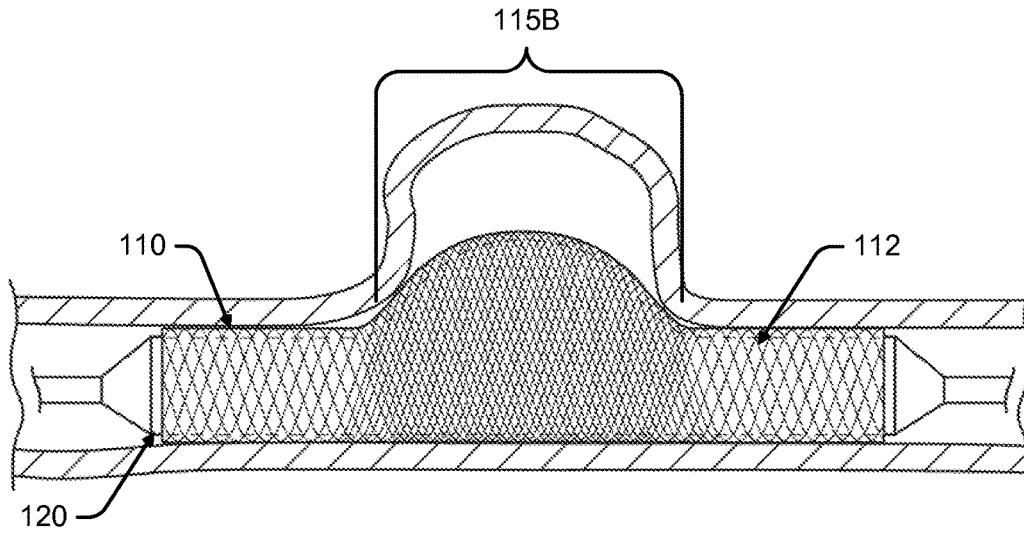

FIG. 5B

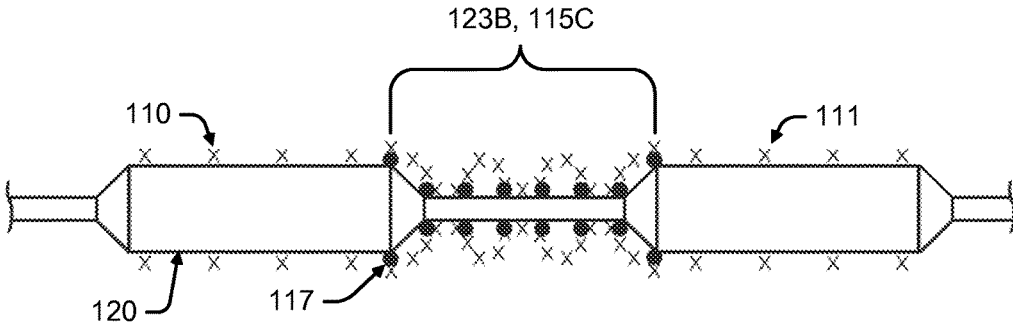

FIG. 6A

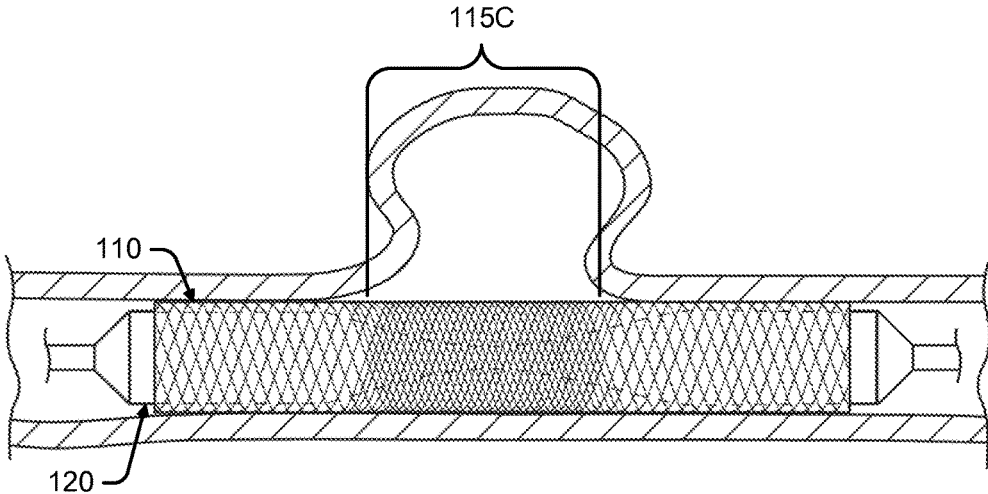

FIG. 6B

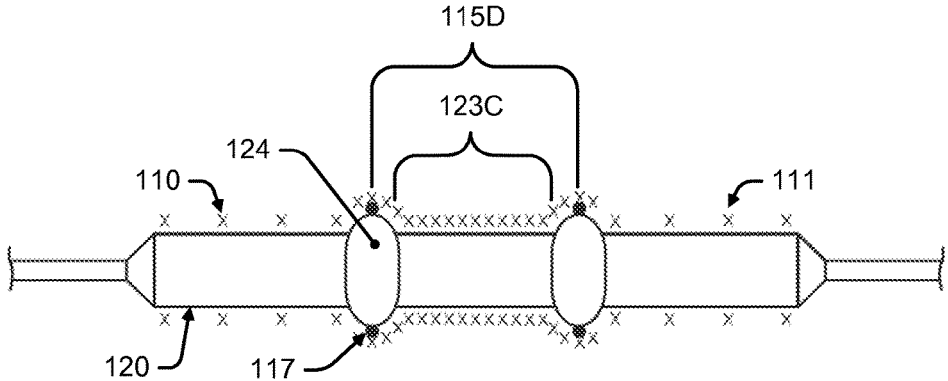

FIG. 7A

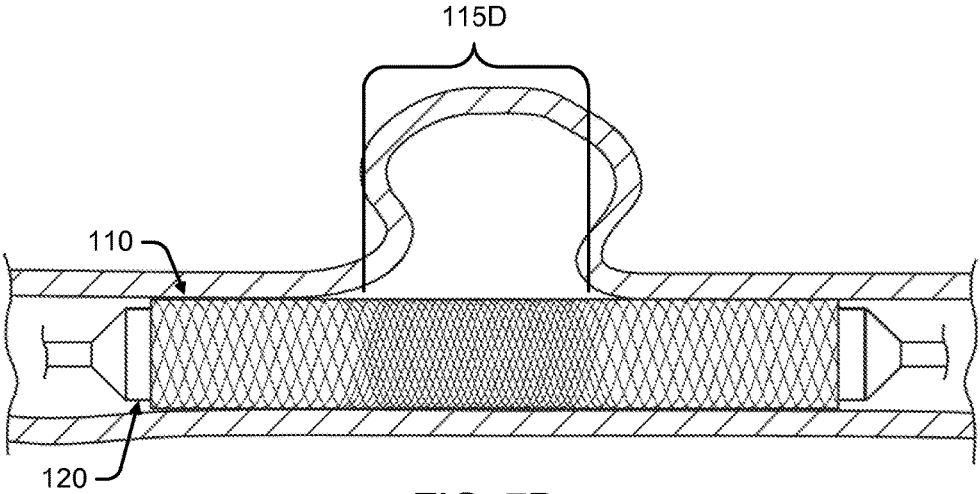

FIG. 7B

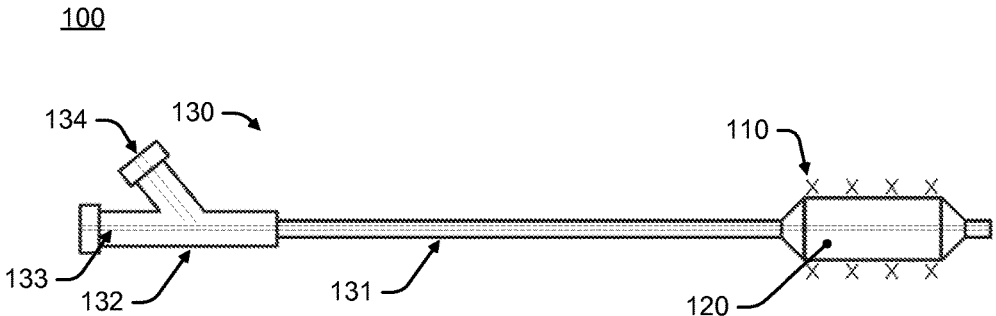

FIG. 8A

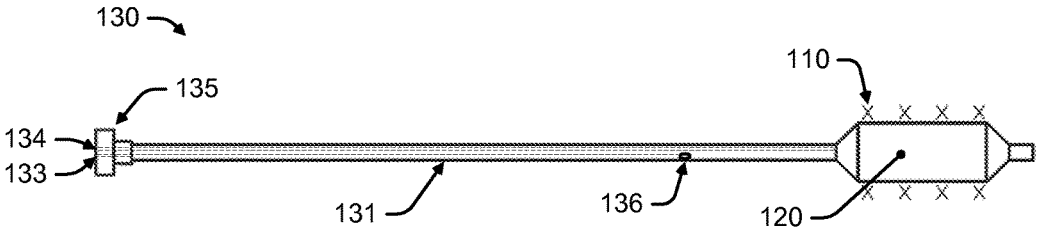

FIG. 8B

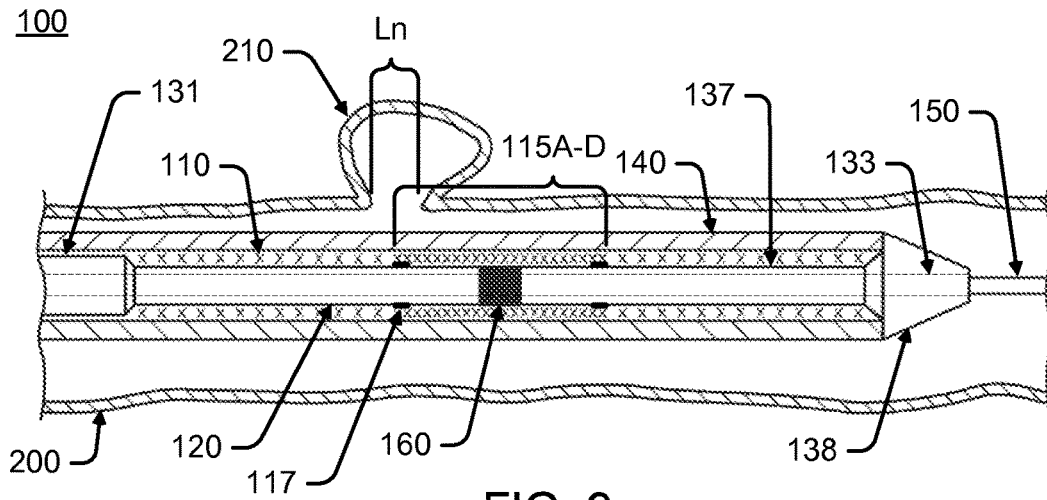

FIG. 9

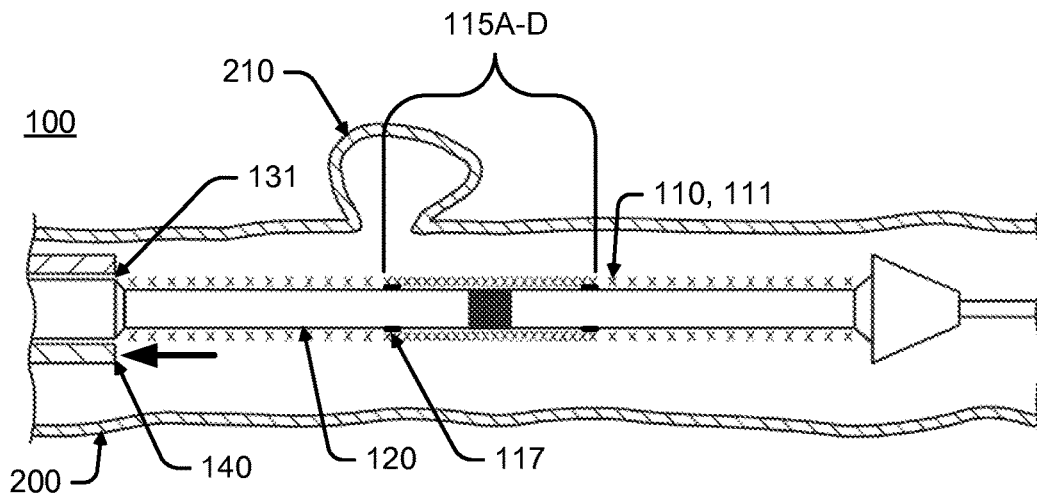

FIG. 10

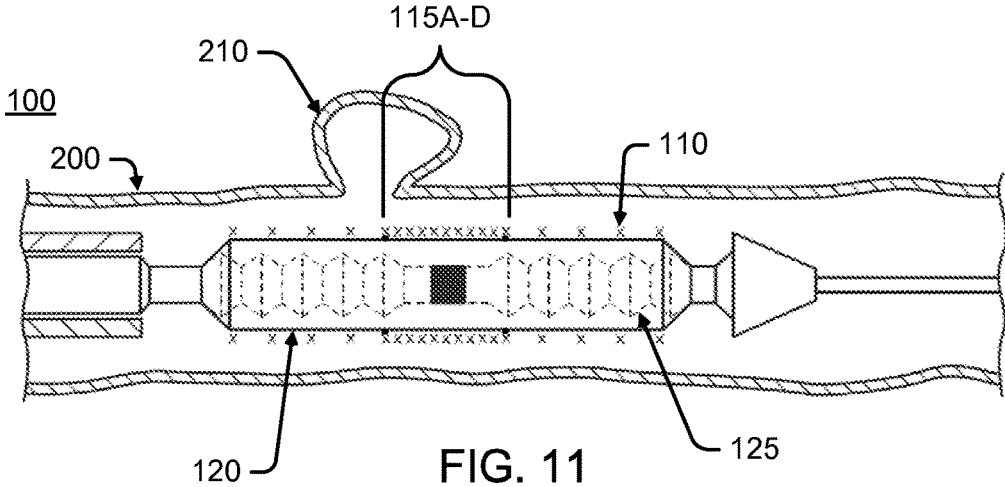

FIG. 11

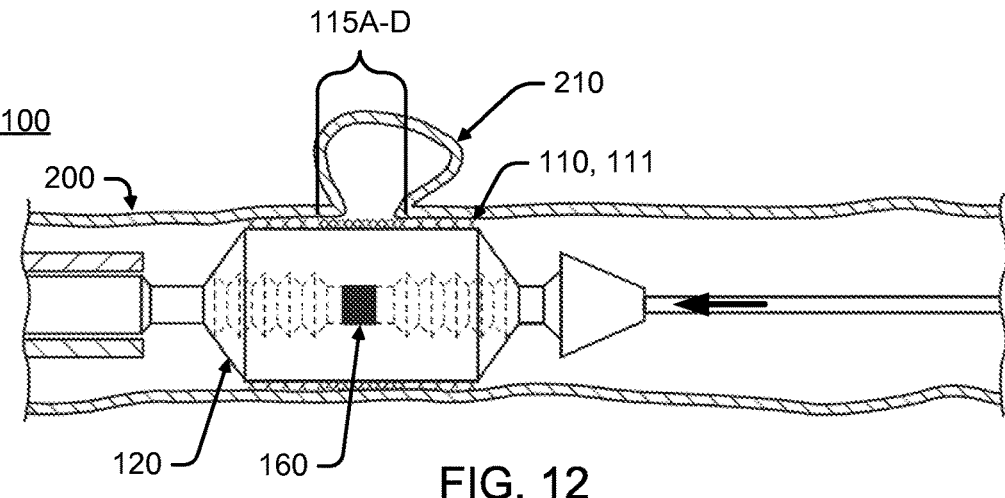

FIG. 12

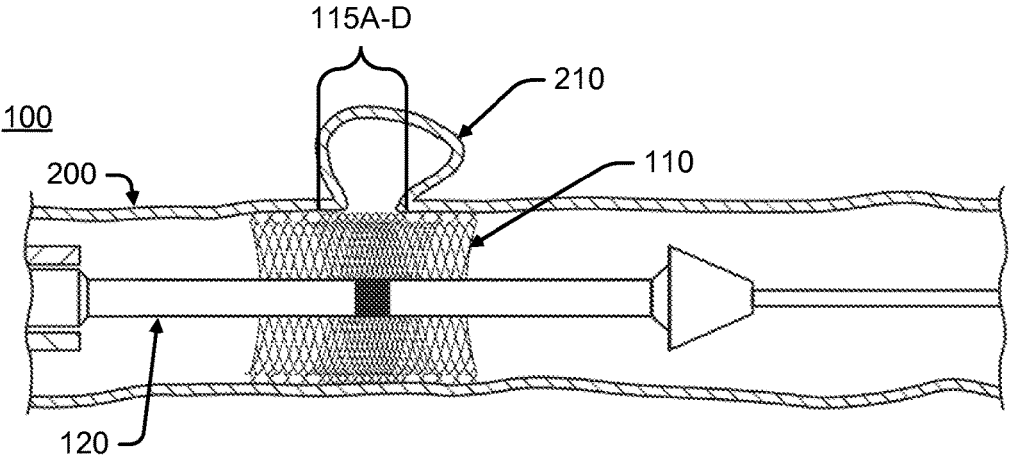

FIG. 13

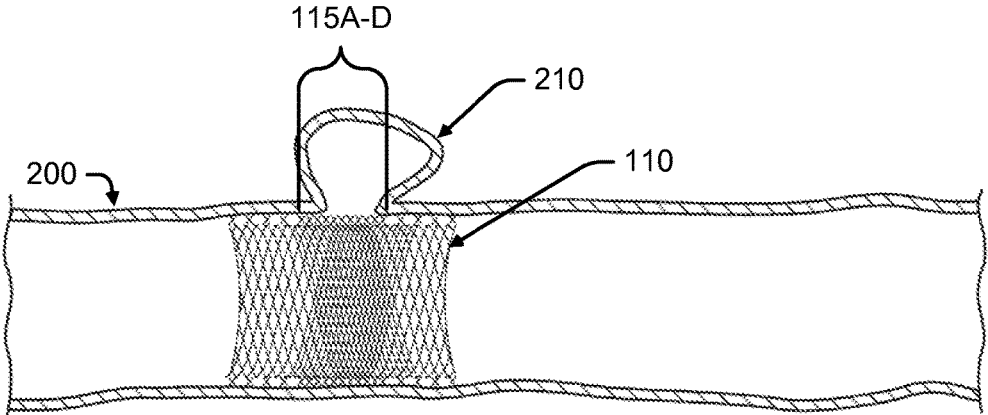

FIG. 14

1

**SYSTEMS FOR ATTAINING A
PREDETERMINED POROSITY OF A
VASCULAR DEVICE**

CROSS-REFERENCE TO RELATED
APPLICATIONS

This application is a continuation of U.S. patent application Ser. No. 13/826,971, filed Mar. 14, 2013, which claims priority benefit of U.S. Provisional Application Ser. No. 61/720,154, filed Oct. 30, 2012, each of which is hereby incorporated herein by reference in its entirety.

BACKGROUND

Lumens in a patient's body can change in size, shape, and/or patency, and such changes can present complications or affect associated bodily functions. For example, the walls of the vasculature, particularly arterial walls, may develop a pathological dilatation, commonly called an aneurysm. Aneurysms are observed as a ballooning-out of the wall of an artery. This is a result of the vessel wall being weakened by disease, injury, or a congenital abnormality. Aneurysms have thin, weak walls and have a tendency to rupture and are often caused or made worse by high blood pressure. Aneurysms can be found in different parts of the body; the most common being abdominal aortic aneurysms (AAA) and the brain or cerebral aneurysms. The mere presence of an aneurysm is not always life-threatening, but an aneurysm can have serious health consequences such as a stroke if one should rupture in the brain. Additionally, a ruptured aneurysm can also result in death.

SUMMARY

The subject technology is illustrated, for example, according to various aspects described below. Various examples of aspects of the subject technology are described as numbered clauses (1, 2, 3, etc.) for convenience. These are provided as examples, and do not limit the subject technology. It is noted that any of the dependent clauses may be combined in any combination, and placed into a respective independent clause, e.g., clause 1, 16 and 23. The other clauses can be presented in a similar manner.

1. A system for treating a patient, the system comprising: an expandable vascular device comprising a body having a substantially uniform porosity that is adapted to change by adjusting an axial length of the body, and an expanding member positioned within a central lumen of the device, the expanding member configured to engage the body, as the body is radially expanded from a collapsed configuration, and to reduce a porosity of the body within a body region more than the body porosity is reduced outside the region.
2. The system of clause 1, wherein the body comprises a braided structure.
3. The system of clause 1, wherein the body comprises a cut metal tube.
4. The system of clause 1, wherein the body comprises a self-expanding structure.
5. The system of clause 1, wherein an axial length of the expanding member in the collapsed configuration is about 200-500% longer than the axial length of the expanding member in an expanded configuration.
6. The system of clause 5, wherein a change in the axial length of the expanding member from the collapsed configuration to the expanded configuration is the same as a

2

change in the axial length of the body from a body collapsed configuration to a body expanded configuration.

7. The system of clause 1, further comprising an adhesive disposed between the expanding member and the region for adhering a portion of the region to the expanding member.

8. The system of clause 7, wherein the adhesive comprises biodegradable material.

9. The system of clause 1, further comprising a corrugated tube disposed within the expanding member, the corrugated tube configured to axially shorten as the expanding member is inflated.

10. The system of clause 1, wherein the expanding member comprises, when expanded, an enlarged region having an enlarged diameter relative to other regions of the expanding member, the enlarged region being substantially axially aligned with the body region.

11. The system of clause 10, further comprising an adhesive disposed between the enlarged region of the expanding member and the body region.

12. The system of clause 1, wherein the expanding member comprises, when expanded, a reduced region having a reduced diameter relative to other regions of the expanding member, the reduced region being substantially axially aligned with the body region.

13. The system of clause 12, further comprising an adhesive disposed proximally or distally of the reduced region of the expanding member.

14. The system of clause 1, wherein the expanding member comprises, when expanded, two enlarged regions having an enlarged diameter relative to a reduced region therebetween, having a reduced diameter, the reduced region being substantially axially aligned with the body region.

15. The system of clause 14, further comprising an adhesive disposed between the enlarged regions and the body.

16. A delivery system for a vascular device, the delivery system comprising:

- a catheter having a lumen;
- a guide wire extending through the catheter lumen;
- a vascular device having a porosity that is altered by adjustment of an axial length of the device; and
- an expanding member disposed within a distal portion of the catheter, the expanding member configured to axially shorten as the expanding member is radially expanded;

wherein the expanding member is configured to engage a region of the device and reduce, as the expanding member axially shortens, a porosity of the device within the region more than the porosity is reduced outside the region.

17. The system of clause 16, wherein an axial length of the expanding member in a collapsed configuration is about 200-500% longer than the axial length of the expanding member in a radially expanded configuration.

18. The system of clause 17, wherein a change in the axial length of the expanding member from the collapsed configuration to the radially expanded configuration is the same as a change in the axial length of the device from a device collapsed configuration to a device expanded configuration.

19. The system of clause 16, further comprising an adhesive disposed between the expanding member and the region for adhering a portion of the region to the expanding member.

20. The system of clause 16, wherein the expanding member comprises, when radially expanded, an enlarged region having an enlarged diameter relative to other regions

of the expanding member, the enlarged region being substantially axially aligned with the region of the device.

21. The system of clause 16, wherein the expanding member comprises, when radially expanded, a reduced region having a reduced diameter relative to other regions of the expanding member, the reduced region being substantially axially aligned with the region of the device.

22. The system of clause 16, wherein the expanding member comprises, when radially expanded, two enlarged regions having an enlarged diameter relative to a reduced region therebetween, having a reduced diameter, the reduced region being substantially axially aligned with the region of the device.

It is understood that other configurations of the subject technology will become readily apparent to those skilled in the art from the following detailed description, wherein various configurations of the subject technology are shown and described by way of illustration. As will be realized, the subject technology is capable of other and different configurations and its several details are capable of modification in various other respects, all without departing from the scope of the subject technology. Accordingly, the drawings and detailed description are to be regarded as illustrative in nature and not as restrictive.

BRIEF DESCRIPTION OF THE DRAWINGS

A detailed description will be made with reference to the accompanying drawings:

FIG. 1A depicts a system for controllably deploying a vascular device in a collapsed configuration, according to some embodiments of the subject technology.

FIG. 1B depicts a system for controllably deploying a vascular device in an intermediate configuration, according to some embodiments of the subject technology.

FIG. 1C depicts a system for controllably deploying a vascular device in an expanded configuration, according to some embodiments of the subject technology.

FIG. 2 depicts a vascular device, according to some embodiments of the subject technology.

FIG. 3A depicts a parison used for manufacturing an expanding member, according to some embodiments of the subject technology.

FIG. 3B depicts an example process for manufacturing an expanding member, according to some embodiments of the subject technology.

FIG. 3C depicts an example process for manufacturing an expanding member, according to some embodiments of the subject technology.

FIG. 3D depicts an expanding member, according to some embodiments of the subject technology.

FIG. 3E depicts an expanding member, according to some embodiments of the subject technology.

FIG. 4A depicts a vascular device coupled to an expanding member using an adhesive, according to some embodiments of the subject technology.

FIG. 4B depicts a vascular device coupled to an expanding member using an adhesive, according to some embodiments of the subject technology.

FIG. 4C depicts a vascular device coupled to an expanding member using an adhesive, according to some embodiments of the subject technology.

FIG. 4D depicts a vascular device coupled to an expanded expanding member using an adhesive, according to some embodiments of the subject technology.

FIG. 5A depicts an expanding member having an enlarged region, according to some embodiments of the subject technology.

FIG. 5B depicts an expanding member having an enlarged region disposed within a vessel, according to some embodiments of the subject technology.

FIG. 6A depicts an expanding member having a reduced region, according to some embodiments of the subject technology.

FIG. 6B depicts an expanding member having a reduced region disposed within a vessel, according to some embodiments of the subject technology.

FIG. 7A depicts an expanding member having two enlarged regions, according to some embodiments of the subject technology.

FIG. 7B depicts an expanding member having two enlarged regions disposed within a vessel, according to some embodiments of the subject technology.

FIG. 8A depicts an example of a catheter, according to some embodiments of the subject technology.

FIG. 8B depicts another example of a catheter, according to some embodiments of the subject technology.

FIG. 9 depicts a cross section view of a vessel and delivery of a vascular device according to some embodiments of the subject technology.

FIG. 10 depicts a cross section view of a vessel and delivery of a vascular device according to some embodiments of the subject technology.

FIG. 11 depicts a cross section view of a vessel and delivery of a vascular device according to some embodiments of the subject technology.

FIG. 12 depicts a cross section view of a vessel and delivery of a vascular device according to some embodiments of the subject technology.

FIG. 13 depicts a cross section view of a vessel and delivery of a vascular device according to some embodiments of the subject technology.

FIG. 14 depicts a cross section view of a vessel and a vascular device according to some embodiments of the subject technology.

DETAILED DESCRIPTION

The detailed description set forth below is intended as a description of various configurations of the subject technology and is not intended to represent the only configurations in which the subject technology may be practiced. The appended drawings are incorporated herein and constitute a part of the detailed description. The detailed description includes specific details for the purpose of providing a thorough understanding of the subject technology. However, it will be apparent to those skilled in the art that the subject technology may be practiced without these specific details. In some instances, well-known structures and components are shown in block diagram form in order to avoid obscuring the concepts of the subject technology.

Aneurysms may be located, for example, along vessel side walls. A neck of an aneurysm typically defines an opening of between about 2 to 25 mm, though other sizes and ranges are also possible. The neck connects an anatomical lumen to a fundus of the aneurysm. In some embodiments, “vessel” or “lumen” may refer to blood vessels (including arteries and veins) or other suitable body organs having a lumen, such as the gastrointestinal tract (e.g., esophagus, stomach, small intestine, colon, rectum), bile ducts, urinary bladder, ureter, urethra, trachea, bronchi, and the like. Blood flow within the anatomical lumen flows

through the neck and into the fundus. In response to the constant blood flow into the fundus of the aneurysm, the wall of the aneurysm continues to distend and presents a significant risk of rupturing. When the blood within the aneurysm causes pressure against the wall of the aneurysm that exceeds the wall strength, the aneurysm ruptures.

Reduction of blood flow to or within the aneurysm results in a reduction in force against the wall of the aneurysm and a corresponding reduction in the risk of rupturing. A reduction of the force and volume of blood entering the aneurysm may be accomplished by an occluding device. Occluding devices may be dependent on a physician's skill during deployment, to ensure that a desired porosity is attained at the neck of the aneurysm. If the porosity too high at the neck, then the occluding device may fail in sufficiently reducing the blood flow into the fundus. The porosity of some occluding devices may be reduced by applying a longitudinally compressive force to a proximal portion of the occluding device towards the direction of a distal portion. Because the porosity of the occluding device may be modified by application of the compressive force, achieving the desired porosity consistently and reliably is heavily dependant on physician skill.

The methods and systems of the subject technology solve some or all of the foregoing problems by controlling the deployment of a vascular device such that the device occludes blood flow into the aneurysm consistently and reliably, to thereby prevent or reduce likelihood of aneurysm ruptures. The system includes an expandable vascular device and an expanding member positioned within a central lumen of the vascular device. The expanding member is configured to attain a predetermined porosity for a region of the device during deployment. Accordingly, controlling the deployment of the vascular device using the expanding member to attain the predetermined porosity for the region, reduces or stops the laminar flow into the aneurysm, thereby allowing the blood within the aneurysm to begin to stagnate. Stagnation of blood, as opposed to continuous flow through a fundus of the aneurysm, results in thrombosis in the aneurysm, which also helps protect the aneurysm from rupturing.

FIGS. 1A-1C depict a system 100 for controllably deploying a vascular device 110, according to some embodiments of the subject technology. The system 100 includes an expandable vascular device 110, an expanding member 120 positioned within a central lumen of the vascular device 110, and a catheter 130.

Referring to FIG. 2, the vascular device 110 comprises a body 111 having a substantially uniform porosity. The body 111 may be formed of a plurality of substantially uniformly spaced members 112. The porosity of the body 111 is adapted to change by adjusting an axial length of the body 111. For example, the body 111 may be configured to decrease in porosity as a result of being axially shortened during and/or after diametrical, or radial, expansion. The body 111 may be a self-expanding stent made of two or more round or ovoid wire filaments 112. Accordingly, the body 111 has a first, collapsed configuration, and a second, expanded configuration. The filaments 112 may be formed of known flexible materials including shape memory materials, such as nitinol, platinum and stainless steel. The body 111 may be fabricated from platinum/8% tungsten and 35N LT (cobalt nickel alloy, which is a low titanium version of MP35N alloy) alloy wires. In other embodiments, one or more of the filaments 112 can be formed of a biocompatible metal material or a biocompatible polymer. The filaments 112 may be braided into a resulting lattice-like structure. In

at least one embodiment, during braiding or winding of the body 111, the filaments 112 may be loosely braided using a 1-over-2-under-2 system. In other embodiments, however, other methods of braiding may be followed, without departing from the scope of the disclosure.

Alternatively, the body 111 may be formed, for example, by laser cutting a pre-formed tube or sheet, by interconnecting a multitude of members 112 by laser welding, or by other suitable methods such as electrochemical etching, grinding, piercing, electroforming, or other means. In another example, the body 111 may comprise a tubular stent.

The body 111 has a porosity configured to reduce hemodynamic flow into, for example, an aneurysm. The porosity of the body 111, determined by the plurality of members 112, may be adjusted by axially shortening the body 111. The ends of the body 111 may be cut to length and therefore remain free for radial expansion and contraction. The body 111 may exhibit a high degree of flexibility due to the materials used, the porosity of the body 111, and the fact that the ends are not secured.

Referring to FIGS. 1A-1C, the expanding member 120 is configured to engage the body 111 of the vascular device 110, as the body 111 is expanded from the first, collapsed configuration. The expanding member 120 may comprise an elastomeric balloon capable of being very elastic, such that an axial length of the expanding member 120 in a collapsed configuration is about 200-500% longer than the axial length of the expanding member 120 in an expanded configuration. The expanding member 120 may be formed from polyurethane, silicone, or other similar materials.

The expanding member 120 is configured to geometrically deform in a similar manner as the vascular device 110, as the body 111 moves from the first, collapsed configuration to the second, expanded configuration. For example, during expansion of the expanding member 120 from the collapsed configuration to the expanded configuration, the expanding member 120 may be configured to shorten in axial length and increase in radial dimension, or diameter, by the same amounts as the body 111 does when the body 111 moves from the first, collapsed configuration to the second, expanded configuration. In other words, a change in the axial length and radial dimension of the expanding member 120 from the collapsed configuration to the expanded configuration is the same as a change in the axial length and radial dimension of the body 111 from the first, collapsed configuration to the second, expanded configuration.

The expanding member 120 may have an inner member 125 disposed within a central longitudinal axis of the expanding member 120 that is configured to axially shorten during expansion or inflation of the expanding member 120. The inner member 125 may be configured to axially shorten by the same amount as the expanding member 120 axially shortens during expansion or inflation. The inner member 125 may, for example, comprise a corrugated tube, telescoping tube, or other structure configured to axially shorten or collapse. A proximal and distal end of the expanding member 120 may be attached, coupled, or adhered to a proximal and distal portion of the inner member 125.

In some aspects, to reduce the tendency of the expanding member 120 to creep or stress relax, the material of the expanding member 120 may be cross-linked. Cross-links are bonds, bi-functional polymer chains or multi-functional polymer chains that link one polymer chain of the expanding member 120 material to another. Cross-links can be formed by chemical reactions that are initiated by heat, pressure, change in pH, radiation, or other means. For example, mixing of an unpolymerized or partially polymerized resin

with specific chemicals called cross-linking reagents results in a chemical reaction that forms cross-links between the polymer chains of the expanding member 120 material. If further protection from creep or stress relaxation is desired, the expanding member 120 could be shipped in an axially shortened and radially expanded configuration, or in the expanded configuration. In this example, the expanding member 120 may be configured to be "at rest" when the expanding member 120 is at its largest diameter and its shortest length.

Referring to FIGS. 3A-3D, the expanding member 120 may be manufactured using molds 310. In this process, a length of polymer tubing (parison) 320 is placed into the mold. Heater elements bring the parison to the working temperature and the parison is then axially stretched and internally pressurized "P" to form the expanding member 120. Using this process, the expanding member 120 may have varying cross sectional shapes either along the expanding member 120 length or normal to the expanding member 120 longitudinal axis, or both. This expanding member 120 manufacturing process may impart axial or biaxial orientation to the polymer chains of which the expanding member 120 may be comprised.

Alternatively, the expanding member 120 may be manufactured by solution casting. Solution casting is a process in which the mold is rotated, causing a solution in the mold to conform to the interior surface of the mold due to centrifugal force. After the solution has cured into a film, the mold is disassembled, thereby releasing the expanding member 120.

Other known methods may also be used to manufacture the expanding member 120. In some examples the expanding member 120 is comprised of wound or braided filaments imbedded in the elastomeric polymer. In another example the expanding member 120 may be comprised of braided filaments which can be axially lengthened or shortened using a telescoping rod and tube, the rod being attached to distal ends of the braided filaments and the tube being attached to proximal ends of the braided filaments.

The expanding member 120 may have a proximal cuff 122A and a distal cuff 122B for attachment to a catheter 130. In another embodiment, the expanding member 120 may only have a proximal cuff 122A, as shown in FIG. 3E. This embodiment is particularly useful for attaching to a distal end of a fixed wire catheter, as discussed further below.

FIGS. 4A-7B depict the vascular device 110 and the expanding member 120, according to some embodiments of the subject technology. The expanding member 120 is positioned within the central lumen of the vascular device 110 before and during deployment of the vascular device 110 within a patient's vasculature. The expanding member 120 may be configured to controllably expand the vascular device 110 such that the vascular device 110 attains a predetermined porosity at a particular region, such as near a treatment site which may be near a neck of an aneurysm. For example, during deployment, the expanding member 120 may cause a reduction in a porosity of the body 111 within a region 115A-D that is more than the reduction of the porosity of the body 111 outside the region 115A-D, thereby attaining a predetermined porosity for the region 115A-D.

Alternatively, the expanding member 120 may be configured to controllably expand the vascular device 110 such that the vascular device 110 attains a predetermined porosity in more than one region, such as proximal and distal to the neck of the aneurysm where pressure may be higher.

Referring to FIGS. 4A-4D, the expanding member 120 may controllably expand the vascular device 110 and attain the predetermined porosity for the region 115A by positively

engaging a portion of the vascular device 110 before and during deployment. For example, an adhesive 117 may be used to positively engage, couple, attach, or adhere a portion of the vascular device 110 to an outer surface of the expanding member 120. The adhesive 117 assists in utilizing the axial shrinkage and radial expansion characteristics of the expanding member 120 to control the porosity of the vascular device 110 by positively engaging, coupling, attaching, or adhering the expanding member 120 to the vascular device 110.

The adhesive 117 may comprise biodegradable materials, or materials that dissolve in the body or in the bloodstream. For example, the adhesive 117 may include sugar, carbowax, polyethylene oxide, poly vinyl alcohol, poly lactic acid (PLA), poly glycolic acid (PGA), poly lactic glycolic acid (PLGA), poly (ε-caprolactone) copolymers, polydioxanone, poly(propylene fumarate) poly(trimethylene carbonate) copolymers, polyhydroxy alkanoates, polyphosphazenes, polyanhydrides, poly(ortho esters), poly(amino acids), or "pseudo"-poly(amino acids).

In some aspects, the expanding member 120 may be configured to allow perfusion of tissues downstream of the expanding member during expansion or inflation of the expanding member 120. Allowing perfusion of tissues downstream also aids in dissolution of the adhesive 117.

Referring to FIG. 4A, in one example, the adhesive 117 may be disposed between the expanding member 120 and a region 115A. The adhesive 117 adheres a portion of the region 115A to the outer surface of the expanding member 120. The adhesive 117 may be applied on the expanding member 120 and/or the vascular device 110, such that it only adheres a proximal and/or distal portion of the region 115A. Referring to FIG. 4C, alternatively, the adhesive 117 may be applied either throughout or at a particular portion of the region 115A. Referring to FIG. 4B, the adhesive 117 may be applied continuously or intermittently on the outer surface of the expanding member 120 or the vascular device 110, depending on the dissolvability and/or fracturability of the adhesive 117. The adhesive 117 may be applied by spray, dip, or other processes.

Referring to FIG. 4D, in one aspect, the adhesive 117 may be applied on the outer surface of the expanding member 120 while the expanding member 120 is uniformly stretched, inflated, partially expanded, and/or in the expanded configuration. For example, the adhesive 117 may be applied on the outer surface of the expanding member 120 when the expanding member 120 is in the expanded configuration and uniformly stretched along its length. In this example, the adhesive 117 may be applied intermittently within the region 115A, such that unadhered areas are formed, as shown in FIG. 4C. The unadhered areas facilitate folding or collapsing of the expanding member 120 and vascular device 110 as the expanding member 120 and vascular device are prepared for deployment within the vasculature and moved to the collapsed configuration.

Alternatively, the adhesive 117 may be applied on the outer surface of the expanding member 120 while the expanding member 120 is deflated, partially collapsed, and/or in the collapsed configuration. In this example, the adhesive 117 may be applied continuously within the region 115A, as shown in FIG. 4B.

In another example, the adhesive 117 may be applied on the outer surface of the expanding member 120 while the expanding member 120 has a portion that is stretched along its length. The stretched portion may correspond to the region 115A of the vascular device 110.

In some aspects, the expanding member 120 and the vascular device 110 are positively engaged, coupled, attached, or adhered such that there is no shear strain in the adhesive 117 when the expanding member 120 and the vascular device 110 are in the expanded configuration. In other aspects, the expanding member 120 and the vascular device 110 are positively engaged, coupled, attached, or adhered such that there is enough shear strain in the adhesive 117, when the expanding member 120 and the vascular device 110 are fully expanded or in the expanded configuration, to fracture or sever the adhesive 117 and thereby release the vascular device 110 from the expanding member 120. In other aspects, the expanding member 120 and the vascular device 110 are positively engaged, coupled, attached, or adhered such that there is enough shear strain in the adhesive 117 when the expanding member 120 and the vascular device 110 are partially expanded to fracture or sever the adhesive 117 and thereby release the vascular device 110 from the expanding member 120 prior to full expansion of the expanding member 120. The shear strain of interest could be axial strain, hoop strain, or a combination of both.

Prior to deployment, the expanding member 120 may be moved to the collapsed configuration, with the vascular device 110 disposed thereon. When in the collapsed configuration, the region 115A of the body 111 will have a higher braid density and lower porosity than other portions of the body 111 due to the adhesive 117 bonding the region 115A to the expanding member 120. During subsequent expansion of the expanding member 120 and the vascular device 110, the overall porosity of the body 111 will decrease as the diameter of the vascular device 110 increases and the axial length of the vascular device 110 shortens. The porosity of the region 115A, however, also decreases and remains less porous than other portions of the body 111 during and after expansion.

Referring to FIGS. 5A-5B, the expanding member 120 may controllably expand the vascular device 110 and attain the predetermined porosity for the region 115B by increasing a diameter of the region 115B of the vascular device 110 to a diameter that is larger than other portions of the vascular device 110. The expanding member 120 may comprise, when expanded, an enlarged region 123A having an enlarged diameter relative to other regions of the expanding member 120. The enlarged region 123A is substantially axially aligned with the region 115B.

The enlarged region 123A of the expanding member 120 increases the diameter of the region 115B to a diameter that is larger than the diameter in other portions of the body 111. Enlarging the diameter of the region 115B causes the members 112 disposed on the other portions of the body 111 to be pulled toward the region 115B, thereby decreasing the porosity within the region 115B. Accordingly, the expanding member 120 causes a reduction in the porosity of the body 111 within the region 115B that is more than the reduction of the porosity of the body 111 outside the region 115B, to thereby attain the predetermined porosity for the region 115B.

In one aspect, the adhesive 117 may be used to positively engage, couple, attach, or adhere the region 115B of the vascular device 110 to the enlarged region 123A of the expanding member 120. The adhesive 117 assists in utilizing the axial shrinkage and radial expansion characteristics of the expanding member 120 to control the porosity of the vascular device 110 by positively engaging, coupling, attaching, or adhering the expanding member 120 to the vascular device 110. The adhesion between the region 115B

of the vascular device 110 and the expanding member 120 ensures that upon deployment, the region 115B attains the predetermined porosity.

Once near the treatment site, the adhesive 117 would begin to dissolve. As the expanding member 120 is expanded, the remaining adhesive 117 will be fractured, thereby further facilitating dissolution of the adhesive 117. The expanding member 120 and the vascular device 110 would expand in the same manner, shortening in axial length while increasing in diameter. The enlarged region 123A of the expanding member 120 would expand to a diameter greater than other portions of the expanding member 120, thereby causing the density within the region 115B to increase and the porosity within the region 115B to decrease, more than the other portions of the body 111.

Referring to FIGS. 6A-6B, the expanding member 120 may controllably expand the vascular device 110 and attain the predetermined porosity for the region 115C by storing excess material of the region 115C of the vascular device 110 within a reduced region 123B of the expanding member 120. For example, the expanding member 120 may comprise, when expanded, the reduced region 123B having a reduced diameter relative to other regions of the expanding member 120. The reduced region 123B is substantially axially aligned with the region 115C and provides an area to store the excess material of the region 115C. In other words, the vascular device 110 may be arranged over the expanding member 120 so that the material of the region 115C may be bunched up and collected, in a highly dense arrangement, within the reduced region 123B of the expanding member 120.

In one aspect, the adhesive 117 may be used to adhere the proximal and/or distal portions of the body 111, with the region 115C unadhered, to the expanding member 120. In another example, the adhesive 117 may be disposed intermittently along the reduced region 123B, as shown in FIG. 6A. The adhesive 117 assists in maintaining the excess material of the region 115C within the reduced region 123B of the expanding member 120 so that upon deployment, the region 115C attains the predetermined porosity. Thus, upon expansion of the expanding member 120, the excess material of the region 115C stored at the reduced region 123B of the expanding member 120 will be deployed with comparatively reduced porosity.

Once near the treatment site, the adhesive 117 would begin to dissolve. As the expanding member 120 is expanded, the remaining adhesive 117 will be fractured, thereby further facilitating dissolution of the adhesive 117. The expanding member 120 and the vascular device 110 would expand in the same manner, shortening in axial length while increasing in diameter. The reduced region 123B of the expanding member 120, which houses the excess material of the region 115C, will begin to enlarge and deploy the excess material contained therein.

Referring to FIGS. 7A-7B, the expanding member 120 may controllably expand the vascular device 110 and attain the predetermined porosity for the region 115D by storing excess material of the region 115D of the vascular device 110 within a region 123C disposed between two enlarged regions 124 of the expanding member 120. For example, the expanding member 120 may comprise, when expanded, two enlarged regions 124 having an enlarged diameter relative to a reduced region 123C therebetween. The reduced region 123C has a reduced diameter, is substantially axially aligned with the region 115D, and provides an area to store the excess material of the region 115D. In other words, the vascular device 110 may be arranged over the expanding

11

member 120 so that the material of the region 115D may be bunched up and collected, in a highly dense arrangement, within the reduced region 123C of the expanding member 120.

In one aspect, the adhesive 117 may be used to adhere the proximal and/or distal portions of the body 111, with the region 115D unadhered, to the enlarged regions 124 of the expanding member 120. The adhesive 117 assists in maintaining the excess material of the region 115D within the reduced region 123C of the expanding member 120 so that upon deployment, the region 115D attains the predetermined porosity. Thus, upon expansion of the expanding member 120, the excess material of the region 115D stored at the reduced region 123C of the expanding member 120 will be deployed with comparatively reduced porosity.

Once near the treatment site, the adhesive 117 would begin to dissolve. As the expanding member 120 is expanded, the remaining adhesive 117 will be fractured, thereby further facilitating dissolution of the adhesive 117. The expanding member 120 and the vascular device 110 would expand in the same manner, shortening in axial length while increasing in diameter. The reduced region 123C of the expanding member 120, which houses the excess material of the region 115D, will begin to enlarge and deploy the excess material contained therein.

Radiopaque markers may be located adjacent the proximal or distal portions of the vascular device 110, and may be located at any position along the length of the vascular device 110 between a proximal and distal end of the vascular device 110, including the region 115A-D. The markers may be attached to the vascular device 110 by techniques such as adhesives, heat fusion, interference fit, fasteners, intermediate members, coatings, or by other techniques.

In some embodiments, the markers are comprised of ultrasonic markers, MRI-safe markers, or other markers. In some embodiments ultrasonic markers permit a physician to accurately determine the position of the vascular device 110 within a patient under ultrasonic visualization. Materials for an ultrasonic marker have an acoustical density sufficiently different from the vascular device 110 to provide suitable visualization via ultrasonic techniques. Exemplary materials comprise polymers, metals such as tantalum, platinum, gold, tungsten and alloys of such metals, hollow glass spheres or microspheres, and other materials.

In some embodiments, MRI-safe markers permit a physician to accurately determine the position of the vascular device 110 within a patient under magnetic resonance imaging. Exemplary materials for making MRI-safe marker have a magnetic signature sufficiently different from the vascular device 110 to provide suitable visualization via MRI techniques. Exemplary materials comprise polymers, metals such as tantalum, platinum, gold, tungsten and alloys of such metals, non-ferrous materials, and other materials.

A technique for treating an aneurysm will now be discussed with reference to FIGS. 8A-14. The vascular device 110 may be delivered into a treatment site using the system 100. The system 100 includes the catheter 130, which may for example, be an over the wire (OTW) catheter, a rapid exchange (multiple lumen) catheter, or a fixed wire catheter.

Referring to FIG. 8A, the OTW catheter includes a shaft 131. A proximal portion of the shaft 131 has a manifold 132 affixed thereto. A distal portion of the shaft 131 has the expanding member 120 affixed thereto. The shaft 131 also includes two lumens, a guide wire lumen 133 and an inflation lumen 134 for expanding or inflating the expanding member 120. A proximal end of each lumen 133, 134 is configured to interface with the manifold 132.

12

Referring to FIG. 8B, the rapid exchange catheter includes a shaft 131 having an inflation lumen 134 extending therethrough. A proximal portion of the shaft 131 has a hub 135 affixed thereto. A distal portion of the shaft 131 has the expanding member 120 affixed thereto. The shaft 131 has two lumens over a distal portion only. The inflation lumen 134 and a guide wire lumen 133 which extends from a distal end of the shaft 131, to a skive 136. At the skive 136, the guide wire lumen 133 terminates and a guide wire communicates with an outer surface of the shaft 131. The inflation lumen 134 is configured to expand or inflate the expanding member 120.

The fixed wire catheter includes a shaft having an inflation lumen only, to which is affixed a hub and the expanding member 120.

Referring to FIG. 9, prior to delivery, the vascular device 110 is mounted to the expanding member 120 either with or without adhesive 117. An outer sheath 140 is disposed over the vascular device 110 and the expanding member 120 to confine, within an annular space between the outer sheath 140 and the expanding member 120, the vascular device 110 in the first, collapsed configuration. The outer sheath 140 also retains the vascular device 110 and the expanding member 120 in an axial elongated and diametrically reduced configuration.

The vascular device 110 and the expanding member 120 may be cooperatively movable within the outer sheath 140 in order to deliver the vascular device 110 to a treatment site, such as an aneurysm, within the vasculature of a patient.

The outer sheath 140 may be configured to be introduced and advanced through the vasculature of the patient. The outer sheath 140 may be made from various thermoplastics, e.g., PTFE, FEP, HDPE, PEEK, etc., which may optionally be lined on the inner surface of the outer sheath 140 or an adjacent surface with a hydrophilic material such as PVP or some other plastic coating. Additionally, either surface may be coated with various combinations of different materials, depending upon the desired results.

The shaft 131 includes the guide wire lumen 133 for allowing a guide wire 150 to extend therethrough. The shaft 131 may also include a reduced diameter at a distal region 137 to provide sufficient annular space in which the vascular device 110 is stowed. In this example, the expanding member 120 would be disposed on the reduced diameter region 137 of the shaft 131.

Radiopaque markers may be provided at various locations along the length of the system 100. For example, an enlarged distal tip 138 of the shaft 131 may be radiopaque. In another example, radiopaque markers may be provided on the reduced diameter distal region 137 of the shaft, beneath the distal and proximal end of the vascular device 110. In yet another example, a radiopaque marker 160 may be disposed on the shaft 131 adjacent to a longitudinal center of the vascular device 110 and/or the expanding member 120.

In one aspect, the vascular devices 110 may be configured with regions 115A-D having different axial lengths. A physician may select the appropriate vascular device 110 based on a size of the neck of the aneurysm and the axial length of the region 115A-D. For example, based on the axial length of the region 115A-D and a length of a neck of the aneurysm "Ln," the vascular device 110 may be selected such that the axial length of the region 115A-D, when the vascular device 110 is in the second, expanded configuration, is longer than the length of the neck of the aneurysm.

In another aspect, the system 100 may be manufactured to ship with the expanding member 120 and the vascular device 110 in the expanded configuration. In this example,

13

after the system **100** is selected such that the as-delivered axial length of the region **115A-D** is longer than the length of the aneurysm, the physician may draw the vascular device **110** and the expanding member **120** assembly proximally into the outer sheath **140** to compress the vascular device and the expanding member **120** assembly. In an alternative embodiment, the system **100** may be manufactured to ship with the expanding member **120** and the vascular device **110** in the collapsed configuration, preloaded in the outer sheath **140**.

Referring to FIG. 9, the system **100** is advanced percutaneously over the guide wire **150** to the treatment site, in this example to the site of an aneurysm **210**. Specifically, the vascular device **110** may be positioned in a vessel **200** at an ostium or the neck of the aneurysm **210**. In one aspect, the radiopaque marker **160** may be positioned distal to a distal lateral wall of the aneurysm **210**, thereby offsetting the region **115A-D** from the ostium of the aneurysm **210** prior to expanding the vascular device **110**. During delivery, any dissolvable adhesive **117** disposed between the vascular device **110** and the expanding member **120** is protected from dissolving by the outer sheath **140**. Specifically, the outer sheath **140** covers the vascular device **110** and the expanding member **120** assembly and thereby prevents any fluids, such as blood, from coming into contact with the adhesive **117**.

Referring to FIG. 10, after navigating the system **100** to the treatment site within the patient, the outer sheath **140** is withdrawn proximally while maintaining the position of the shaft **131** to thereby expose a distal portion of the shaft **131**, the expanding member **120**, and the vascular device **110**. The outer sheath **140** is withdrawn until a distal end of the outer sheath **140** is proximal of the vascular device **110** and the expanding member **120** assembly.

If the vascular device **110** comprises a self-expanding stent, then portions of the vascular device that may be unadhered to the expanding member **120** may partially diametrically expand and partially axially shorten. In this example the region **115A-D** will maintain a higher density and lower porosity than other portions of the body **111**, during and after deployment, because of the adhesive **117** disposed between the region **115A-D** and the expanding member **120**. The adhesive **117** thereby allows the expandable member **120** to controllably expand the vascular device **110** and attain the predetermined porosity for the region **115A-D** by positively engaging the vascular device **110**. Alternatively, if the vascular device **110** does not comprise a self-expanding stent, then the vascular device **110** remains on the expanding member **120**. As the outer sheath **140** is withdrawn, thereby exposing the vascular device **110** and the expanding member **120** assembly, the adhesive **117** begins to make contact with fluids, such as blood. The adhesive **117** begins to dissolve due to the contact with the fluid.

Referring to FIG. 11, as the expanding member **120** is partially expanded or inflated using the inflation lumen **134**, the expanding member **120** and hence, the vascular device **110**, partially diametrically expand and partially axially shorten. During expansion of the expanding member **120**, the inner member **125** also axially shortens by the same amount as the expanding member **120** and/or the vascular device **110**.

Referring to FIG. 12, the system **100** is then withdrawn proximally, until the radiopaque marker **160** is centered along the length of the ostium or neck of the aneurysm **210**. In other words, after the vascular device **110** has been repositioned such that the region **115A-D** is centered along the length of the ostium, the region **115A-D** will cover the

14

ostium or neck of the aneurysm **210** when the vascular device **110** is in the second, expanded configuration.

The expanding member **120** is then expanded to the fully expanded configuration, thereby fully deploying the vascular device **110**. The expanding member **120** will diametrically expand and axially shrink, while maintaining the vascular device **110** to its outer surface due to the remaining adhesive **117** disposed between the vascular device **110** and the expanding member. The expanding member **120** controllably expands the vascular device **110** such that the vascular device **110** attains the predetermined porosity at the region **115A-D**. During deployment, the expanding member **120** causes a reduction in the porosity of the body **111** within the region **115A-D** that is more than the reduction of the porosity of the body **111** outside the region **115A-D**, thereby attaining the predetermined porosity for the region **115A-D**.

The adhesive **117** disposed between the expanding member **120** and the vascular device **110** may dissolve and/or fracture during or after expansion of the expanding member **120**, thereby releasing the vascular device **110** from the expanding member **120**.

The expanding member **120** thereby causes the region **115A-D** to attain the pre-programmed porosity regardless of the endless variety of physician induced movements that can occur during the deployment of the vascular device **110**. Stated another way, the porosity of the region **115A-D** is relatively insensitive to physician applied motions during deployment of the vascular device **110**.

Referring to FIG. 13, once the entire vascular device **110** is fully expanded, the expanding member **120** is collapsed or deflated. Referring to FIG. 14, thereafter, the catheter **130**, along with the outer sheath **140**, shaft **131**, expanding member **120**, and guide wire **150** may be withdrawn from the body.

The region **115A-D** of the vascular device **110** has a significantly lower porosity compared to other portions of the body **111**. Due to the lower porosity of the region **115A-D**, less blood flows into the aneurysm **210** such that substantial thrombosis may occur within the aneurysm **210**.

In one arrangement, the vascular device **110** may be comprised of metal, polymer, ceramic, permanent enduring materials, and may comprise either of or both of non-bioabsorbable and bioabsorbable materials. Exemplary materials include, but are not limited to, NITINOL®, stainless steel, cobalt chromium alloys, Elgiloy, magnesium alloys, polylactic acid, poly glycolic acid, poly ester amide (PEA), poly ester urethane (PEU), amino acid based bio-analogous polymers, tungsten, tantalum, platinum, polymers, bio-polymers, ceramics, bio-ceramics, or metallic glasses. Part or all of the medical device may elute over time substances such as drugs, biologics, gene therapies, anti-thrombotics, coagulants, anti-inflammatory drugs, immunomodulator drugs, anti-proliferatives, migration inhibitors, extracellular matrix modulators, healing promoters, re-endothelialization promoters, or other materials. In some embodiments, the vascular device **110** may be formed from materials having shape memory properties. In some embodiments, the vascular device **110** may be finished by processes to remove slag. In some embodiments, the vascular device **110** may be subjected to a tempering treatment at temperatures customarily applied to the material so that the impressed structure is permanently established.

The vascular device **110** may have various lengths and diameters. For example, the vascular device **110** may have specific cross-sectional diameters, the diameters being measured when the vascular device **110** is fully free to expand, ranging from about 2 mm to about 6 mm. If the vascular

15

device **110** has a diameter between 3 mm and 4 mm, it may be used in a size 18 microcatheters (i.e., microcatheters with an inner diameter of approximately 0.21 inch). If the vascular device **110** has a diameter between 5 mm and 6 mm, it may be used in a size 27 microcatheters (i.e., microcatheters with an inner diameter of approximately 0.027 inch). However, other suitable cross-sectional diameters may be used without deviating from the scope of the subject technology. In some embodiments, the vascular device **110** may have lengths, measured proximally to distally along the longitudinal axis of the vascular device **110**, ranging from 15 mm to 40 mm, though other ranges and sizes are also possible.

Skilled artisans may implement the described functionality in varying ways for each particular application. Various components and blocks may be arranged differently (for example, arranged in a different order, or partitioned in a different way) all without departing from the scope of the subject technology. It is understood that the specific order or hierarchy of steps in the processes disclosed is an illustration of exemplary approaches. Based upon design preferences, it is understood that the specific order or hierarchy of steps in the processes may be rearranged. Some of the steps may be performed simultaneously. The accompanying method claims present elements of the various steps in a sample order, and are not meant to be limited to the specific order or hierarchy presented.

The previous description is provided to enable any person skilled in the art to practice the various aspects described herein. The previous description provides various examples of the subject technology, and the subject technology is not limited to these examples. Various modifications to these aspects will be readily apparent to those skilled in the art, and the generic principles defined herein may be applied to other aspects. Thus, the claims are not intended to be limited to the aspects shown herein, but is to be accorded the full scope consistent with the language claims, wherein reference to an element in the singular is not intended to mean "one and only one" unless specifically so stated, but rather "one or more." Unless specifically stated otherwise, the term "some" refers to one or more. Pronouns in the masculine (for example, his) include the feminine and neuter gender (for example, her and its) and vice versa. Headings and subheadings, if any, are used for convenience only and do not limit the invention.

A phrase such as an "aspect" does not imply that such aspect is essential to the subject technology or that such aspect applies to all configurations of the subject technology. A disclosure relating to an aspect may apply to all configurations, or one or more configurations. An aspect may provide one or more examples. A phrase such as an aspect may refer to one or more aspects and vice versa. A phrase such as an "aspect" does not imply that such aspect is essential to the subject technology or that such aspect applies to all configurations of the subject technology. A disclosure relating to an aspect may apply to all aspects, or one or more aspects. An aspect may provide one or more examples. A phrase such as an "aspect" may refer to one or more aspects and vice versa. A phrase such as a "configuration" does not imply that such configuration is essential to the subject technology or that such configuration applies to all configurations of the subject technology. A disclosure relating to a configuration may apply to all configurations, or one or more configurations. A configuration may provide one or more examples. A phrase such as a "configuration" may refer to one or more configurations and vice versa.

16

The word "exemplary" is used herein to mean "serving as an example or illustration." Any aspect or design described herein as "exemplary" is not necessarily to be construed as preferred or advantageous over other aspects or designs.

All structural and functional equivalents to the elements of the various aspects described throughout this disclosure that are known or later come to be known to those of ordinary skill in the art are expressly incorporated herein by reference and are intended to be encompassed by the claims. Moreover, nothing disclosed herein is intended to be dedicated to the public regardless of whether such disclosure is explicitly recited in the claims. No claim element is to be construed under the provisions of 35 U.S.C. §112, sixth paragraph, unless the element is expressly recited using the phrase "means for" or, in the case of a method claim, the element is recited using the phrase "step for." Furthermore, to the extent that the term "include," "have," or the like is used in the description or the claims, such term is intended to be inclusive in a manner similar to the term "comprise" as "comprise" is interpreted when employed as a transitional word in a claim.

What is claimed is:

1. A system for treating a patient, the system comprising: an expandable vascular device comprising a body having a porosity affectable by adjusting an axial length of the body, and an expanding member positioned within a central lumen of the device, the expanding member being engageable with the body such that, as the body is radially expanded from a collapsed configuration and while engaged by the expanding member, a porosity within a region of the body is changed more than a porosity outside the region of the body is changed.
2. The system of claim 1, wherein the body comprises a braided structure.
3. The system of claim 1, wherein the body comprises a self-expanding structure.
4. The system of claim 1, wherein an axial length of the expanding member in the collapsed configuration is about 200-500% longer than the axial length of the expanding member in an expanded configuration.
5. The system of claim 4, wherein a change in the axial length of the expanding member from the collapsed configuration to the expanded configuration is the same as a change in the axial length of the body from a body collapsed configuration to a body expanded configuration.
6. The system of claim 1, further comprising an adhesive disposed between the expanding member and the region for adhering a portion of the region to the expanding member.
7. The system of claim 1, further comprising a corrugated tube disposed within the expanding member, the corrugated tube configured to axially shorten as the expanding member is inflated.
8. The system of claim 1, wherein the expanding member comprises, when expanded, an enlarged region having an enlarged diameter relative to other regions of the expanding member, the enlarged region being substantially axially aligned with the body region.
9. The system of claim 8, further comprising an adhesive disposed between the enlarged region of the expanding member and the body region.
10. The system of claim 1, wherein the expanding member comprises, when expanded, a reduced region having a reduced diameter relative to other regions of the expanding member, the reduced region being substantially axially aligned with the body region.

17

11. The system of claim 10, further comprising an adhesive disposed proximally or distally of the reduced region of the expanding member.

12. The system of claim 1, wherein the expanding member comprises, when expanded, two enlarged regions having an enlarged diameter relative to a reduced region therebetween, having a reduced diameter, the reduced region being substantially axially aligned with the body region.

13. The system of claim 12, further comprising an adhesive disposed between the enlarged regions and the body.

14. A delivery system for a vascular device, the delivery system comprising:

a catheter having a lumen;

a guide wire extending through the catheter lumen;

a vascular device having a porosity affectable by adjustment of an axial length of the device; and

an expanding member disposed within a distal portion of the catheter, the expanding member having an axial length that is adjustable as the expanding member is radially expanded;

wherein the expanding member is engageable with a region of the device such that, during adjustment of the axial length of the expanding member and while the expanding member engages the region, a porosity within the region of the device is changed more than a porosity outside the region of the device is changed.

15. The system of claim 14, wherein the axial length of the expanding member in a collapsed configuration is about

18

200-500% longer than the axial length of the expanding member in a radially expanded configuration.

16. The system of claim 15, wherein a change in the axial length of the expanding member from the collapsed configuration to the radially expanded configuration is the same as a change in the axial length of the device from a device collapsed configuration to a device expanded configuration.

17. The system of claim 14, further comprising an adhesive disposed between the expanding member and the region for adhering a portion of the region to the expanding member.

18. The system of claim 14, wherein the expanding member comprises, when radially expanded, an enlarged region having an enlarged diameter relative to other regions of the expanding member, the enlarged region being substantially axially aligned with the body region.

19. The system of claim 14, wherein the expanding member comprises, when radially expanded, a reduced region having a reduced diameter relative to other regions of the expanding member, the reduced region being substantially axially aligned with the body region.

20. The system of claim 14, wherein the expanding member comprises, when radially expanded, two enlarged regions having an enlarged diameter relative to a reduced region therebetween, having a reduced diameter, the reduced region being substantially axially aligned with the body region.

* * * * *