



(12) **United States Patent**
Labrot

(10) **Patent No.:** **US 9,855,727 B2**
(45) **Date of Patent:** ***Jan. 2, 2018**

(54) **GLASS PANE AS HEAD-UP DISPLAY**

(75) Inventor: **Michael Labrot**, Aachen (DE)

(73) Assignee: **SEKISUI CHEMICAL CO., LTD.**,
Osaka (JP)

(*) Notice: Subject to any disclaimer, the term of this patent is extended or adjusted under 35 U.S.C. 154(b) by 568 days.

This patent is subject to a terminal disclaimer.

(21) Appl. No.: **13/819,197**

(22) PCT Filed: **Aug. 22, 2011**

(86) PCT No.: **PCT/EP2011/064354**

§ 371 (c)(1),
(2), (4) Date: **Jun. 3, 2013**

(87) PCT Pub. No.: **WO2012/038170**

PCT Pub. Date: **Mar. 29, 2012**

(65) **Prior Publication Data**

US 2013/0242562 A1 Sep. 19, 2013

(30) **Foreign Application Priority Data**

Sep. 21, 2010 (EP) 10177778

(51) **Int. Cl.**

B32B 17/10 (2006.01)
F21V 3/04 (2006.01)

(Continued)

(52) **U.S. Cl.**

CPC .. **B32B 17/10431** (2013.01); **B32B 17/10018**
(2013.01); **B32B 17/10669** (2013.01); **B32B**
17/10761 (2013.01); **C08K 5/0041** (2013.01);

F21V 3/0418 (2013.01); **G02B 27/01**
(2013.01); **B32B 2367/00** (2013.01); **G02B**
2027/0112 (2013.01); **G02B 2027/0194**
(2013.01); **Y10T 428/266** (2015.01); **Y10T**
428/269 (2015.01); **Y10T 428/2848** (2015.01)

(58) **Field of Classification Search**

USPC 428/341, 354, 426, 412, 523, 474.4
See application file for complete search history.

(56) **References Cited**

U.S. PATENT DOCUMENTS

2,490,662 A 12/1949 Thomsen
5,549,786 A * 8/1996 Jones H01L 21/31116
257/E21.252

(Continued)

FOREIGN PATENT DOCUMENTS

CN 1464884 A 12/2003
CN 101302301 A 11/2008

(Continued)

OTHER PUBLICATIONS

Breniaux et al., WO 2011042384A1, Composite glass pane as a head-up display, Apr. 14, 2011 (Machine Translation)*

(Continued)

Primary Examiner — Cheng Huang

(74) *Attorney, Agent, or Firm* — Cheng Law Group, PLLC

(57) **ABSTRACT**

A glass pane is described. The glass pane has at least one pane, and one adhesive layer on the pane. The adhesive layer has at least one thermoplastic film with a luminescent pigment and a barrier film with an anti-scratch coating.

25 Claims, 5 Drawing Sheets

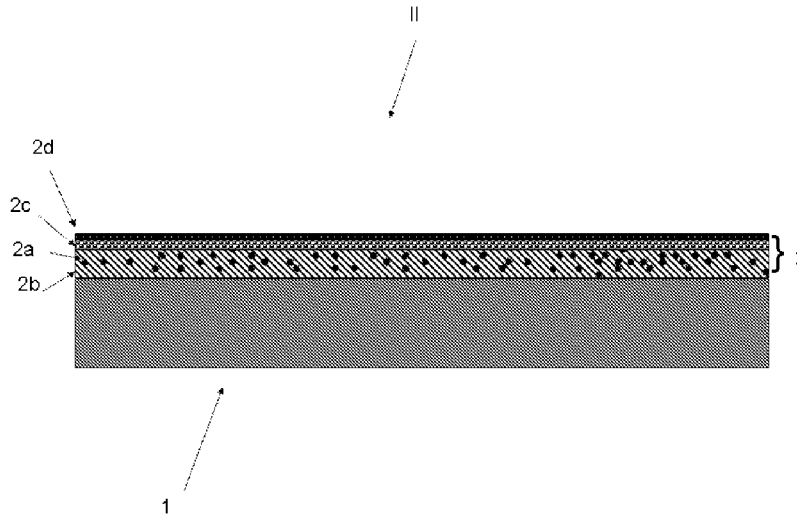

(51) **Int. Cl.**
G02B 27/01
C08K 5/00

(2006.01)
(2006.01)

FOREIGN PATENT DOCUMENTS

DE	822714	C	11/1951	
DE	4024330	A1	2/1992	
DE	19918811	A1	11/2000	
DE	10002152	A1	7/2001	
DE	10350529	A1	3/2005	
DE	102005061855	A1	7/2007	
DE	60314613		6/2008	
DE	102009044181	A1	4/2011	
DE	WO 2011042384	A1 *	4/2011 B32B 17/10036
EP	0157030		10/1985	
EP	0734852	A2	10/1996	
EP	0990941		4/2000	
EP	2110237	A1	10/2009	
EP	2233962	A2	9/2010	
FR	2929016	A1	9/2009	
FR	2929017		9/2009	
GB	2424382	A	9/2006	
JO	2004-341210	A	12/2004	
JP	EP 0597391	A1 *	5/1994 C03C 17/34
JP	H07149988	A	6/1995	
JP	H09327898	A	12/1997	
JP	H10119110	A	5/1998	
JP	2000-168352	A	6/2000	
JP	2001113588	A	4/2001	
JP	2001-249399	A	9/2001	
JP	2002241371	A	8/2002	
JP	2003340851	A	12/2003	
JP	2007001122	A	1/2007	
JP	2007-527548	A	9/2007	
JP	2008-235681	A	10/2008	
JP	2008-260498	A	10/2008	
JP	2009-86182	A	4/2009	
JP	2009-139940	A	6/2009	
JP	2009145846	A	7/2009	
JP	2009-539120	A	11/2009	
JP	2010-243940	A	10/2010	
JP	2010-271443	A	12/2010	
KR	10-1999-0071481	A	9/1999	
KR	1020000068557	A	11/2000	
KR	10-2005-0086398	A	6/2005	
WO	194496	A	12/2001	
WO	2004/099172		11/2004	
WO	2007/039850	A1	4/2007	
WO	2008/132368	A2	11/2008	
WO	2010139889	A1	12/2010	

(56) **References Cited**

U.S. PATENT DOCUMENTS

5,573,842	A	11/1996	Gutweiler	
6,002,505	A	12/1999	Kraenert et al.	
6,072,686	A	6/2000	Yarbrough	
6,670,603	B2	12/2003	Shimada et al.	
6,708,595	B1 *	3/2004	Chaussade B32B 17/10064 428/911
6,879,499	B2	4/2005	Matsumoto	
7,012,746	B2	3/2006	Bermel	
7,090,355	B2	8/2006	Liu et al.	
7,230,767	B2	6/2007	Walck et al.	
7,261,842	B2	8/2007	Henry et al.	
8,072,686	B2	12/2011	Cui et al.	
8,339,332	B2	12/2012	Kanou	
8,487,277	B2	7/2013	Labrot et al.	
8,519,362	B2	8/2013	Labrot et al.	
8,722,195	B2	5/2014	Labrot et al.	
2001/0005262	A1	6/2001	Tsurushima	
2001/0041251	A1	11/2001	Bravet et al.	
2002/0120916	A1	8/2002	Snider, Jr.	
2003/0166788	A1	9/2003	Papenfuhs	
2003/0193044	A1	10/2003	Henry et al.	
2005/0007562	A1	1/2005	Seki et al.	
2005/0074591	A1 *	4/2005	Zagdoun 428/212
2005/0077647	A1	4/2005	Coyle et al.	
2006/0065735	A1	3/2006	Li et al.	
2006/0153558	A1	7/2006	Tan et al.	
2006/0171007	A1	8/2006	Chen et al.	
2006/0221021	A1	10/2006	Hajjar et al.	
2006/0221022	A1	10/2006	Hajjar	
2006/0227087	A1	10/2006	Hajjar et al.	
2006/0244925	A1	11/2006	Seki et al.	
2007/0014318	A1	1/2007	Hajjar et al.	
2007/0046176	A1	3/2007	Bukesov et al.	
2007/0187616	A1	8/2007	Burroughs et al.	
2007/0188417	A1	8/2007	Hajjar et al.	
2007/0206258	A1	9/2007	Malyak et al.	
2007/0228927	A1	10/2007	Kindler et al.	
2008/0203901	A1	8/2008	Bukesov et al.	
2008/0231738	A1	9/2008	Iida	
2008/0259431	A1	10/2008	Weichmann et al.	
2008/0291140	A1	11/2008	Kent et al.	
2008/0318063	A1	12/2008	Anderson	
2009/0033884	A1	2/2009	Yonekubo et al.	
2009/0115100	A1	5/2009	Nakai et al.	
2009/0141496	A1	6/2009	Yamamoto et al.	
2009/0153582	A1	6/2009	Hajjar et al.	
2009/0174632	A1	7/2009	Hajjar et al.	
2010/0063176	A1 *	3/2010	Kato A61K 6/0276 523/116
2010/0243858	A1	9/2010	Newman et al.	
2010/0253600	A1 *	10/2010	Seder B32B 17/10036 345/7
2011/0073773	A1	3/2011	Labrot et al.	
2011/0074660	A1	3/2011	Hajjar et al.	
2011/0076473	A1	3/2011	Lin et al.	
2011/0109529	A1	5/2011	Hajjar et al.	
2011/0141150	A1	6/2011	Hajjar et al.	
2011/0164158	A1	7/2011	Iida	
2011/0176208	A1	7/2011	Kindler et al.	
2011/0181948	A1	7/2011	Kindler et al.	
2011/0291554	A1	12/2011	Bukesov et al.	
2012/0068083	A1	3/2012	Labrot et al.	
2012/0299328	A1	11/2012	Labrot et al.	
2014/0218803	A1	8/2014	Labrot et al.	
2014/0232707	A1	8/2014	Alschinger et al.	
2016/0011414	A1	1/2016	Joseph	

OTHER PUBLICATIONS

PCT International Search Report mailed on Nov. 3, 2011 for PCT Application PCT/EP2011/064354 filed on Aug. 22, 2011 in the name of Saint-Gobain Glass France (English + German).
PCT Written Opinion mailed on Nov. 3, 2011 for PCT Application PCT/EP2011/064354 filed on Aug. 22, 2011 in the name of Saint-Gobain Glass France (English + German).
Edge, M. et al. "Identification of luminescent species contributing to the yellowing of poly(ethylene terephthalate) on degradation" Polymer vol. 36; No. 2; 1995; pp. 227-234.
Day, M., et al., Photochemical Degradation of Poly (ethylene Terephthalate). I. Irradiation Experiments with the Xenon and Carbon Arc, J. Applied Polymer Science Jan. 1972, 16: 175-189.
International Search Report for PCT/EP2010/064734 filed Oct. 4, 2010 on behalf of Saint-Gobain Glass France. Dated Jan. 19, 2011. 7 pages. German original + English translation.
Written Opinion for PCT/EP2010/064734 filed Oct. 4, 2010 on behalf of Saint-Gobain Glass France. Dated Jan. 19, 2011. 15 pages. German original + English translation.
Written Opinion for PCT/EP2012/052338 filed Feb. 10, 2012 on behalf of Saint-Gobain Glass France. Dated Nov. 5, 2012. 13 pages. German original + English translation.
International Search Report for PCT/EP2012/052338 filed Feb. 10, 2012 on behalf of Saint-Gobain Glass France. Dated Nov. 5, 2012. 7 pages. German original + English translation.
Written Opinion for PCT/EP2012/064666 filed Jul. 26, 2012 on behalf of Saint-Gobain Glass France. Dated Oct. 5, 2012. 13 pages. German original + English translation.

(56)

References Cited

OTHER PUBLICATIONS

International Search Report for PCT/EP2012/064666 filed Jul. 26, 2012 on behalf of Saint-Gobain Glass France. Dated Oct. 5, 2012. 9 pages. German original + English translation.

Non-Final Office Action for U.S. Appl. No. 13/499,235, filed Aug. 2, 2012 on behalf of Michael Labrot. Dated Oct. 1, 2013. 13 pages.

Notice of Allowance for U.S. Appl. No. 13/499,235, filed Aug. 2, 2012 on behalf of Michael Labrot. Dated Mar. 14, 2014. 7 pages.

Non-Final Office Action for U.S. Appl. No. 14/110,916, filed Dec. 11, 2013 on behalf of Michael Labrot. Dated Nov. 12, 2015. 18 pages.

Final Office Action for U.S. Appl. No. 14/110,916, filed Dec. 11, 2013 on behalf of Michael Labrot. Dated May 13, 2016. 14 pages.

Notice of Allowance for U.S. Appl. No. 14/110,916, filed Dec. 11, 2013 on behalf of Michael Labrot. Dated Jan. 4, 2017. 9 pages.

* cited by examiner

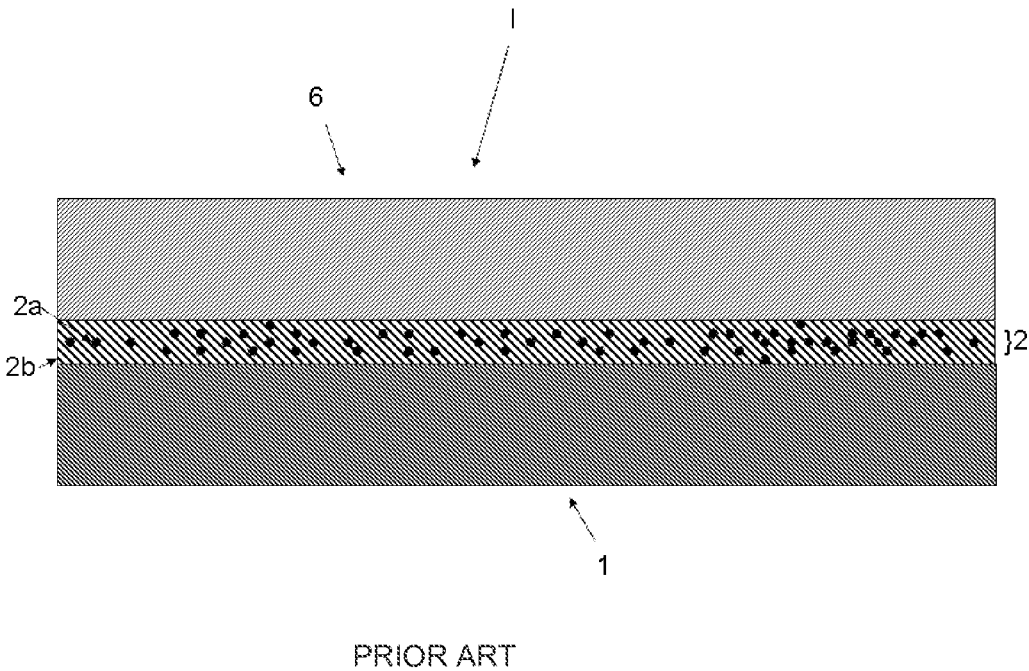

FIG. 1

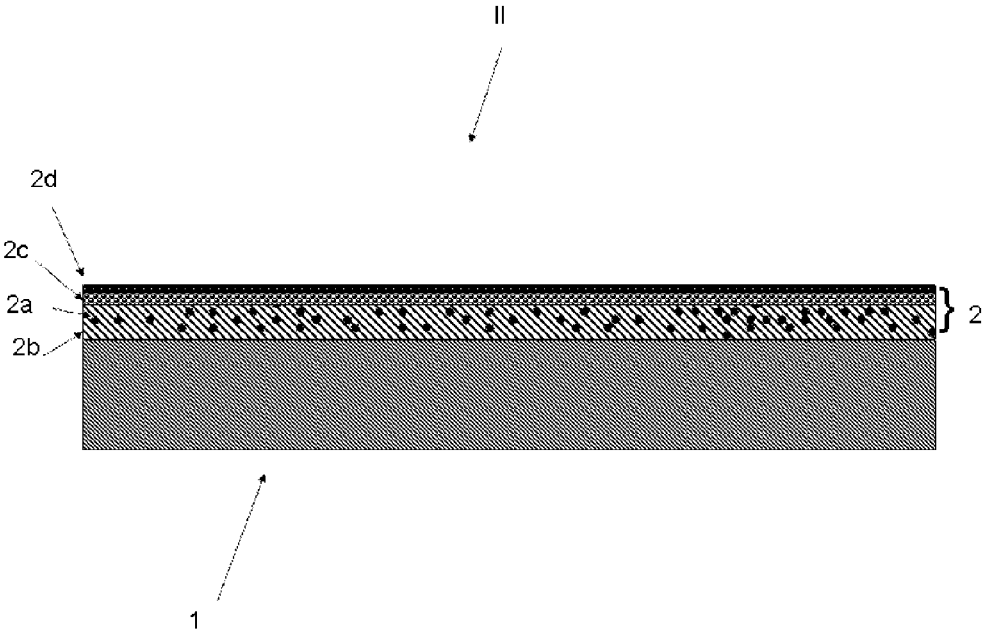

FIG. 2

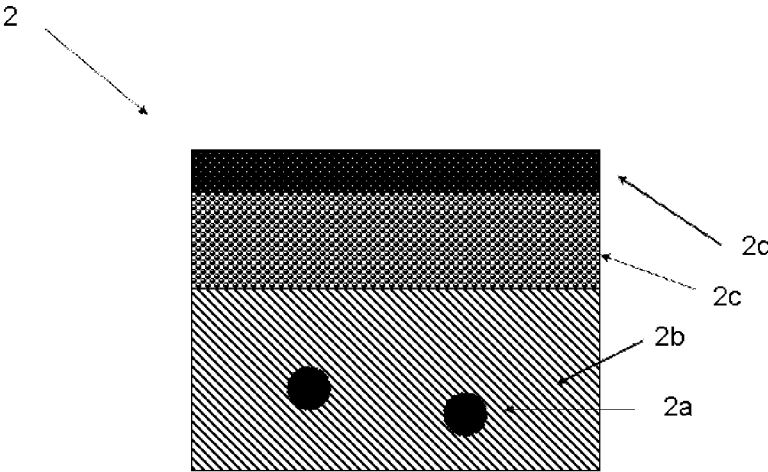

FIG. 3

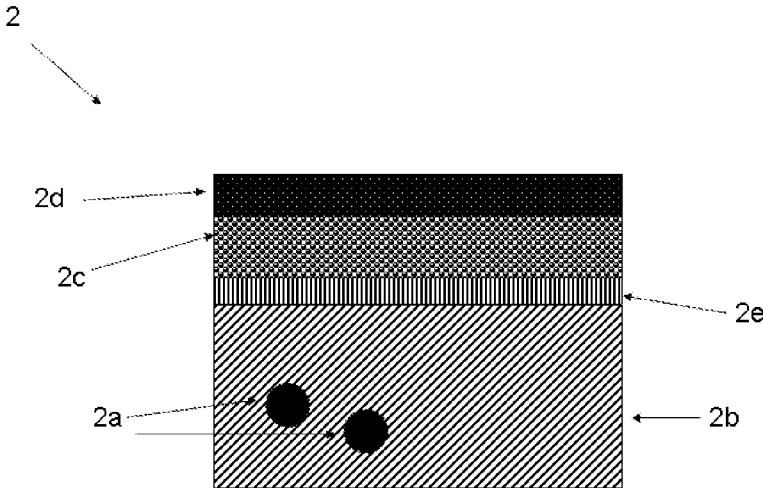

FIG. 4

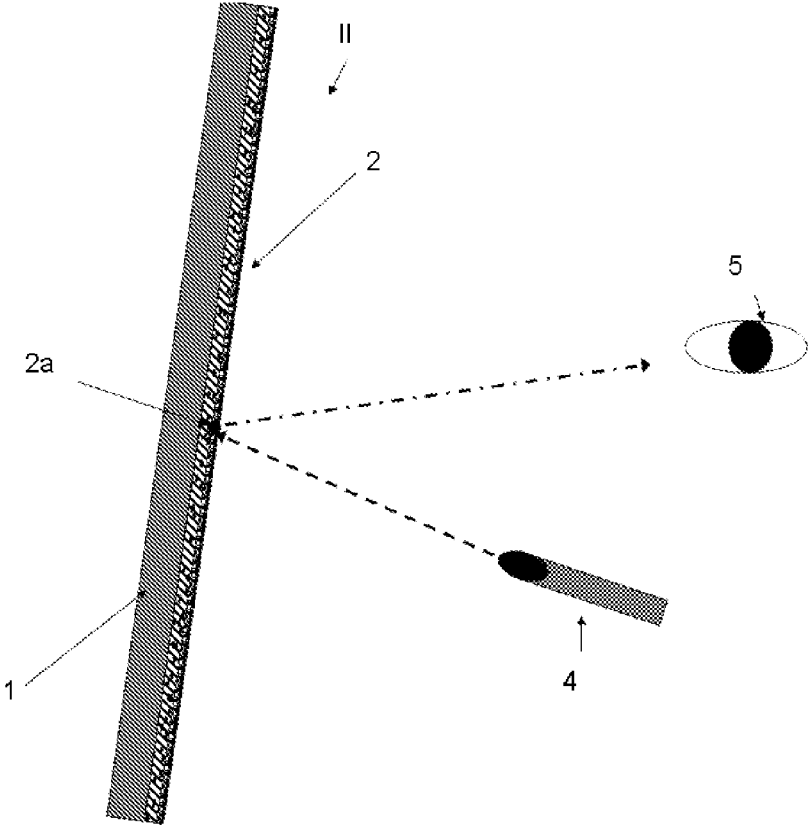

FIG. 5

GLASS PANE AS HEAD-UP DISPLAY

CROSS REFERENCE TO RELATED APPLICATIONS

The present application is the US national stage of International Application PCT/EP2011/064354 filed on Aug. 22, 2011 which, in turn, claims priority to European Patent Application EP 10177778.7 filed on Sep. 21, 2010.

The invention relates to a glass pane, a method for producing the glass pane, and its use as a head-up display.

Head-up displays (HUDs) are widespread in aviation. The systems mounted in the direct field of vision of pilots display the most important data about their own and other aircraft. These systems, established and much used in the military sector, also have many possibilities for use in the civil sector, in particular in the automobile sector. Thus, data about the speed, the distance from the preceding vehicle or directional data from the navigation equipment can, in contrast to head-down displays (HDDs), be displayed right at the eye level of the driver. These capabilities clearly improve the traffic safety of the vehicle as the driver cannot watch the traffic situation while looking at the instruments. At increased speeds of the motor vehicle, on freeways, for example, the distance traveled "blind" by the vehicle can be significant and can cause an increased accident risk.

If head-up displays (HUDs) are illuminated by an external light source, such as a laser, the light fields can be seen only with difficulty depending on the prevailing light and weather conditions. Strong sunlight and light reflection through drops of water or particles of dirt make seeing the data projected in the head-up display significantly more difficult. This is particularly clearly evident with virtual images that are projected onto the display area, for example, the front window. Disadvantages of these conventional HUDs are also the limited field of vision for presentation of the projected data. Real images generated on the display area by electromagnetically excited dyes or pigments constitute a possible approach to a solution. In this case, the entire pane can, in principle, be used as a data carrier.

Because of the size of the pane and the tendency of the pigments to distribute themselves uniformly in the adhesive layer, relatively high concentrations of the chromophoric pigments are necessary. The treatment of the glass pane in the autoclave intensifies the dissolution of the pigments in the adhesive layer. However, in many cases, high pigment concentrations are very expensive and sometimes require special precautionary measures in light of the regulatory classification and handling of pigments or dyes as hazardous substances.

DE 603 14 613 T2 discloses a photochromic composition and a method for its production. The composition contains a linear, cross-linkable polyurethane or polyurethane-urea polymer and a photochromic organic compound.

WO 2004099172 A1 discloses a photochromic composition on a benzo-, naphtho-, and phenanthrochromic structure substituted with an arylamine group.

U.S. Pat. No. 7,230,767 B2 discloses an image display system in a motor vehicle window pane. The arrangement contains luminescent compounds on the outward facing side of the inner pane. The luminescent compounds are illuminated by a light source and appear in the field of vision of an automobile driver.

The object of the invention is to provide a glass pane that can be used as a head-up display and enables good recog-

nizability as well as high luminosity in one or a plurality of colors under all light conditions even with low pigment or dye concentrations.

The object of the present invention is accomplished according to the invention by means of the independent claim 1. Preferred embodiments are given by the subclaims.

A method according to the invention for producing a glass pane with head-up display, a device, and their use emerge from other coordinated claims.

The glass pane according to the invention comprises at least one pane and at least one polymer adhesive layer. The pane preferably contains flat glass (float glass), quartz glass, borosilicate glass, soda lime glass. The pane preferably has average light transmission (unless otherwise specified as light transmission for light type A and a 2°-standard observer according to DIN 5033 for light of the wavelengths from 380 nm to 780 nm) of more than 80%, preferably more than 90%. The pane preferably has light transmission of >70%, particularly preferably 75% in the wavelength range from 360 nm to 420 nm.

The adhesive layer contains at least a first luminescent pigment, a thermoplastic film, and a barrier film. The adhesive layer is disposed with the thermoplastic film side on the pane and fixedly bonded to the pane. The barrier film is disposed on the side of the adhesive layer facing away from the pane. The thermoplastic film preferably contains PVB (polyvinyl butyral) or EVA (poly-ethyl-vinyl acetate). The luminescent first pigments are preferably contained in the entire first thermoplastic film volume. The barrier film acts as a diffusion barrier for the luminescent pigments. The anti-scratch coating on the side of the barrier film facing away from the pane acts as a hard, scratch-resistant surface. The barrier film preferably contains less than 20%, particularly preferably less than 10%, and more particularly preferably less than 1% of the concentration of luminescent pigment than in the thermoplastic film. The luminescent pigments contain, in the context of the invention, organic and/or inorganic luminescent compounds, ions, aggregates, and/or molecules. Luminescence includes fluorescence and/or phosphorescence processes, excitation with electromagnetic radiation, and emission of electromagnetic radiation. The radiation emitted preferably has a different wavelength from the exciting radiation. The radiation emitted preferably has a higher wavelength. The thermoplastic film and further thermoplastic films, if any, preferably have light transmission of >70%, particularly preferably >82%, measured at a wavelength of 405 nm. The light transmission of the thermoplastic films can be adjusted by film thickness, polymer composition, degree of polymerization, distribution of polymerization, UV blockers, or plasticizers.

The barrier film preferably contains polybutylene terephthalate (PBT), polycarbonate (PC), polyethylene terephthalate (PET), and polyethylene naphthalate (PEN), polyvinyl chloride (PVC), polyvinyl fluoride (PVF), polyvinyl butyral (PVB) without plasticizer, and/or copolymers thereof, particularly preferably polyethylene terephthalate (PET).

The barrier film preferably has light transmission of >70%, particularly preferably >80%, measured at a wavelength of 405 nm.

The thermoplastic film preferably has light transmission of >75%, preferably >82%, in the wavelength range from 390 nm to 410 nm.

The adhesive layer preferably contains PVC (polyvinyl chloride), RV (polyurethane), EVA (poly-ethyl vinyl acetate), and mixtures as well as copolymers thereof.

3

The barrier film preferably contains a second luminescent pigment or dye. The second luminescent pigment preferably has a different excitation wavelength and emission wavelength from the first luminescent pigment. Alternatively, further thermoplastic films with luminescent pigments and barrier films lying therebetween can be disposed.

The adhesive layer preferably contains no other UV blockers active in the range of the excitation spectrum of the fluorescent particles between 360 nm and 400 nm. The luminescent pigments according to the invention preferably act as UV blockers.

The luminescent pigment preferably has a local excitation maximum in the range from 350 nm to 450 nm, particularly preferably 390 nm to 420 nm.

The luminescent pigment preferably has a local emission maximum in the range from 400 nm to 800 nm.

The anti-scratch coating preferably contains organically and/or inorganically bound SiO_2 , TiO_2 , Al_2O_3 , Si_3N_4 , preferably polysiloxane. The anti-scratch coating is disposed on the barrier film on the side of the adhesive layer facing away from the pane.

The adhesive layer preferably has a thickness of 0.30 mm to 1.2 mm, preferably 0.70 mm to 0.90 mm. The barrier film preferably has a thickness of 0.10 mm to 0.30 mm. The thermoplastic film preferably has a thickness of 0.3 mm to 0.9 mm.

The luminescent pigment preferably contains a hydroxy-alkyl terephthalate with the formula: $\text{R}_1\text{—COO—P(OH)}_x$ (0-4)- COO—R_2 , where R_1 , R_2 is an alkyl or allyl residue with 1 to 10 C atoms, P is a phenyl ring, OH is hydroxyl groups bonded to the phenyl ring, and x is the number of hydroxyl groups bonded to the phenyl ring. The general structural formula is:

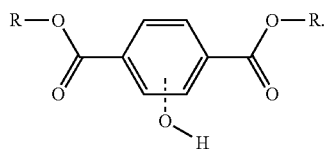

The luminescent pigment preferably contains diethyl 2,5-dihydroxyterephthalate. The structural formula is:

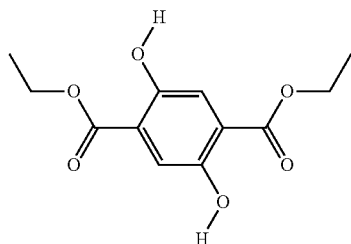

The luminescent pigment preferably contains benzopyranes, naphthopyranes, 2H-naphthopyranes, 3H-naphthopyranes, 2H-phenanthropyranes, 3H-phenanthropyranes, photochromic resins, coumarins, xanthenes, naphthalinic acid derivatives, oxazoles, stilbenes, styryls, perylenes, naphthalimides, naphthals, phenyls, xanthenes, lanthanides, preferably $\text{Y}_2\text{O}_3\text{:Eu}$, $\text{YVO}_4\text{:Tm}$, $\text{Y}_2\text{O}_2\text{S:Pr}$, $\text{Gd}_2\text{O}_2\text{S:Tb}$, and/or mixtures thereof.

The thermoplastic film preferably contains 0.1 gm^2 to 15 gm^2 of luminescent pigment. The quantity indications are based on a thickness of the thermoplastic film of roughly 0.76 mm.

4

The pane preferably has a thickness of 1 mm to 8 mm, particularly preferably 1.4 mm to 2.5 mm.

The barrier film preferably has a coating, preferably a metallic coating, particularly preferably, ZnO , Ag , In_2O_3 , TiO_2 , AlN . The coating intensifies the action of the barrier film as a diffusion barrier for the luminescent pigments or dyes. The coating is preferably disposed on the barrier film adjacent the thermoplastic film.

The invention further comprises a device for displaying a pictogram, numbers, and graphic characters. The device comprises a glass pane as described above and a light source directed to the glass pane. The light source emits electromagnetic radiation, preferably electromagnetic radiation of the wavelength of 360 nm to 420 nm. The radiation emitted by the light source is absorbed by the luminescent pigments in the adhesive layer and is re-emitted with a changed wavelength. This emitted radiation is perceived by the viewer as a pixel on the pane. The light source preferably comprises a diode laser or laser scanner.

The invention further comprises a method for producing a glass pane. In a first step, a thermoplastic film (preferably PVB or EVA) and a barrier film (preferably PET) with an anti-scratch coating (preferably polysiloxane) are bonded to form an adhesive layer (lamination film) on the outside of the barrier film. Then, a luminescent pigment is applied on the thermoplastic film side of the adhesive layer. In the following step, the adhesive layer is laminated between a pane (on the thermoplastic film side) and a lamination pane (on the barrier film side having the anti-scratch coating). The lamination preferably occurs at temperatures from 120° C. to 170° C., a pressure of 10 bar to 15 bar, and for a period of 30 min to 240 min. During lamination, the luminescent pigments are distributed preferably uniformly in the entire thermoplastic film and only slightly in the barrier film. After lamination, the barrier film preferably contains less than 1 wt.-% of a first luminescent pigment in the thermoplastic film. Subsequently, the lamination pane is carefully removed and a composite of a pane and an adhesive layer is obtained.

The luminescent pigment is preferably applied by spraying, screen printing, offset printing, ink jet printing, and/or flexographic printing.

The invention further comprises the use of the glass pane as transparent or (partially) tinted display systems, head-up display in buildings, motor vehicles, airplanes, and/or helicopters, particularly preferably as windshield in motor vehicles.

In the following, the invention is explained in detail with reference to the drawings and an exemplary embodiment as well as a comparative example. The drawings are purely schematic representations and are not to scale. They in no way restrict the invention.

They depict:

FIG. 1 a cross-section of a laminated glass pane with luminescent particles according to the prior art,

FIG. 2 a cross-section of a glass pane according to the invention,

FIG. 3 a cross-section of the adhesive layer according to the invention,

FIG. 4 a cross-section of a preferred embodiment of the adhesive layer according to the invention,

FIG. 5 a schematic view of the device according to the invention.

FIG. 1 depicts a cross-section of a glass pane (1) with luminescent particles (2a) according to the prior art. The glass pane (1) comprises at least one pane (1), one other pane (6), and at least one polymer adhesive layer (2). The adhesive layer (2) comprises a thermoplastic film (2b) made

of PVB and luminescent pigments or dyes (2a), which are statistically distributed in the thermoplastic film (2b) after lamination of the glass pane (I). The broad distribution of the pigments (2a) in the thermoplastic film (2b) makes a high pigment concentration necessary, since luminosity is adequately high only with high pigment density (2a).

FIG. 2 depicts a cross-section of a glass pane (II) according to the invention. The glass pane (II) comprises at least one pane (1) and at least one polymer adhesive layer (2). The adhesive layer (2) comprises a first thermoplastic film (2b) made of PVB and luminescent pigments (2a) distributed in the thermoplastic film (2b). Following the first thermoplastic film (2b) is a barrier film (2c) made of PET, which is virtually free of luminescent pigments or dyes (2a). The expression "virtually free" means, in the context of the invention, no emission of electromagnetic radiation in the barrier film (2c) discernible to the naked eye upon excitation with a suitable radiation source. The barrier film (2c) contains an anti-scratch coating (2d) made of polysiloxane.

FIG. 3 depicts an enlarged cross-section of the adhesive layer (2) according to the invention made of the thermoplastic film (2b) with luminescent particles (2a) as well as the barrier film (2c) following the thermoplastic film (2b) and anti-scratch coating (2d) made of polysiloxane.

FIG. 4 depicts an enlarged cross-section of a preferred embodiment of the adhesive layer (2) according to the invention made of a thermoplastic film (2b) with luminescent particles (2a) and the barrier film (2c) following the first thermoplastic film (2b) and anti-scratch coating (2d). The barrier film (2c) has, adjacent the thermoplastic film (2b), a metallic coating (2e). This metallic coating can be implemented, for example, IR reflective or electrically heatable.

FIG. 5 depicts a cross-section of the device according to the invention. The glass pane (II) comprises a pane (1) and adhesive layer (2). The adhesive layer (2) is illuminated by a light source (4), preferably a laser scanner. The luminescent pigments (2a) situated in the adhesive layer (2) emit light that is perceived by the viewer.

LIST OF REFERENCE CHARACTERS

- (1) pane,
- (2) adhesive layer,
- (2a) luminescent pigment or dye,
- (2b) thermoplastic film,
- (2c) barrier film,
- (2d) anti-scratch coating,
- (2e) coating between barrier film and thermoplastic film,
- (3) lamination pane,
- (4) light source,
- (5) viewer, and
- (6) second pane,

The invention claimed is:

1. A glass pane, comprising:

a pane, and

an adhesive layer on the pane,

wherein the adhesive layer comprises at least one thermoplastic film with a first luminescent pigment and a barrier film with an anti-scratch coating, wherein the first luminescent pigment contains a hydroxyalkyl terephthalate with formula: $R_1-COO-P(OH)xCOO-R_2$ where R_1 R_2 is an alkyl or allyl residue with 1 to 10 C atoms, P is a phenyl ring, OH is hydroxyl groups bonded to the phenyl ring, and x is the number of hydroxyl groups bonded to the phenyl ring having a

value between 0 and 4 and wherein the at least one thermoplastic film contains 0.1 g/m² to 15 g/m² of the first luminescent pigment.

2. The glass pane according to claim 1, wherein the barrier film contains a second luminescent pigment.

3. The glass pane according to claim 2, wherein the first luminescent pigment or the second luminescent pigment have an excitation maximum in a range from 350 nm to 450 nm, an emission maximum in a range from 400 nm to 800 nm, or an excitation maximum in a range from 350 nm to 450 nm and an emission maximum in a range from 400 nm to 800 nm.

4. The glass pane according to claim 3, wherein the excitation maximum is in the range of 390 nm to 420 nm.

5. The glass pane according to claim 3, wherein the emission maximum is in the range from 430 nm to 500 nm.

6. The glass pane according to claim 1, wherein the pane comprises a prestressed or partially prestressed safety glass.

7. The glass pane according to claim 1, wherein the barrier film contains polybutylene terephthalate, polycarbonate, polyethylene terephthalate, polyethylene naphthalate, polyvinyl chloride, polyvinyl fluoride, polyvinyl butyral without plasticizer, and/or mixtures and copolymers thereof.

8. The glass pane according to claim 7, wherein the barrier film contains polyethylene terephthalate.

9. The glass pane according to claim 1, wherein the anti-scratch coating contains organically or inorganically bound SiO₂, TiO₂, Al₂O₃, or Si₃N₄.

10. The glass pane according to claim 9, wherein the anti-scratch coating contains organically or inorganically bound polysiloxane.

11. The glass pane according to claim 1, wherein the adhesive layer has a thickness of 0.30 mm to 0.9 mm.

12. The glass pane according to claim 11, wherein the adhesive layer has a thickness of 0.50 mm to 0.80 mm.

13. The glass pane according to claim 1, wherein the first luminescent pigment contains benzopyranes, naphthopyranes, 2H-naphthopyranes, 3H-naphthopyranes, 2H-phenanthropyranes, 3H-phenanthropyranes, photochromic resins, coumarins, xanthenes, naphthalic acid derivatives, oxazoles, stilbenes, styryls, perylenes, lanthanides, and/or mixtures thereof.

14. The glass pane according to claim 13, wherein the first luminescent pigment contains Y₂O₃:Eu, YVO₄:Tm, Y₂O₂S:Pr, Gd₂O₂S:Tb, and/or mixtures thereof.

15. The glass pane according to claim 1, wherein the pane has a thickness of 1 mm to 8 mm.

16. The glass pane according to claim 15, wherein the pane has a thickness of 1.4 mm to 2.5 mm.

17. The glass pane according to claim 1, wherein the barrier film has a metallic coating.

18. The glass pane according to claim 17, wherein the metallic coating is ZnO, Ag, In₂O₃, Ti, TiO₂, and/or AlN.

19. A device for displaying a pictogram, graphic characters, and/or numbers, comprising:

the glass pane according to claim 1, and

a light source directed to the glass pane, wherein the light source emits electromagnetic radiation onto the glass pane.

20. The device according to claim 19, wherein the light source comprises a laser.

21. The device according to claim 20, wherein the laser is a diode laser.

22. The glass pane according to claim 1, wherein the first luminescent pigment contains diethyl 2,5-dihydroxyterephthalate.

7

23. A method for producing a glass pane, comprising:
 bonding a at least one thermoplastic film and a barrier film
 with an anti-scratch coating to form an adhesive layer,
 applying a luminescent pigment on the at least one
 thermoplastic film of the adhesive layer, 5
 laminating the adhesive layer between a pane and a
 lamination pane,
 removing the lamination pane, and
 obtaining the glass pane having the pane and the adhesive
 layer on the pane, wherein the adhesive layer comprises 10
 the at least one thermoplastic film with the luminescent
 pigment and the barrier film with the anti-scratch
 coating, wherein the luminescent pigment contains a
 hydroxyalkyl terephthalate with formula: R_1-COO-
 $P(OH)_xCOO-R_2$ where R_1 , R_2 is an alkyl or allyl 15
 residue with 1 to 10 C atoms, P is a phenyl ring, OH is
 hydroxyl groups bonded to the phenyl ring, and x is the
 number of hydroxyl groups bonded to the phenyl ring
 having a value between 0 and 4 and wherein the at least
 one thermoplastic film contains 0.1 g/m^2 to 15 g/m^2 of
 luminescent pigment.

8

24. A method comprising:
 using a glass pane as a head-up display in buildings,
 motor vehicles, airplanes, and/or helicopters,
 wherein the glass pane comprises a pane and an adhe-
 sive layer on the pane, wherein the adhesive layer
 comprises at least one thermoplastic film with a first
 luminescent pigment and a barrier film with an
 anti-scratch coating, wherein the first luminescent
 pigment contains a hydroxyalkyl I terephthalate with
 formula: $R_1-COO-P(OH)_xCOO-R_2$, where R_1 ,
 R_2 is an alkyl or allyl residue with 1 to 10 C atoms,
 P is a phenyl ring, OH is hydroxyl groups bonded to
 the phenyl ring, and x is the number of hydroxyl
 groups bonded to the phenyl ring having a value
 between 0 and 4 and wherein the at least one
 thermoplastic film contains 0.1 g/m^2 to 15 g/m^2 of
 the first luminescent pigment.
 25. The method according to claim 24, wherein the glass
 pane is used as windshield motor vehicles or as a billboard.

* * * * *