



(12) **United States Patent**
Kurz et al.

(10) **Patent No.:** **US 9,853,483 B2**
(45) **Date of Patent:** **Dec. 26, 2017**

- (54) **WIRELESS CHARGING COIL**
- (71) Applicant: **A.K. Stamping Company, Inc.**,
Mountainside, NJ (US)
- (72) Inventors: **Arthur Kurz**, New Vernon, NJ (US);
Bernard Duetsch, Summit, NJ (US);
Joshua Kurz, Jersey City, NJ (US)
- (73) Assignee: **A.K. Stamping Company, Inc.**,
Mountainside, NJ (US)
- (*) Notice: Subject to any disclaimer, the term of this
patent is extended or adjusted under 35
U.S.C. 154(b) by 71 days.
- (21) Appl. No.: **14/705,398**
- (22) Filed: **May 6, 2015**
- (65) **Prior Publication Data**
US 2015/0244203 A1 Aug. 27, 2015

Related U.S. Application Data

- (63) Continuation of application No. 14/553,617, filed on
Nov. 25, 2014, now Pat. No. 9,490,656, and a
(Continued)
- (51) **Int. Cl.**
H01F 5/00 (2006.01)
H02J 7/02 (2016.01)
(Continued)
- (52) **U.S. Cl.**
CPC **H02J 7/025** (2013.01); **H01F 5/00**
(2013.01); **H01F 27/2847** (2013.01);
(Continued)
- (58) **Field of Classification Search**
CPC H01F 5/00; H01F 27/00–27/30
(Continued)

(56) **References Cited**
U.S. PATENT DOCUMENTS

3,214,315 A 10/1965 Hildebrand
5,142,767 A 9/1992 Adams et al.
(Continued)

FOREIGN PATENT DOCUMENTS

CN 102084440 6/2011
EP 2645385 A2 10/2013
(Continued)

OTHER PUBLICATIONS

International Search Report of the International Searching Authority
dated Feb. 26, 2015, issued in connection with International Appli-
cation No. PCT/US14/67440 (3 pages).
(Continued)

Primary Examiner — Tuyen Nguyen
(74) *Attorney, Agent, or Firm* — McCarter & English,
LLP

(57) **ABSTRACT**

A wireless charging coil is provided herein. More specifi-
cally, provided herein is a wireless charging coil comprising
a first stamped coil having a first spiral trace, the first spiral
trace defining a first space between windings, and a second
stamped coil having a second spiral trace, the second spiral
trace defining a second space between windings, the first
stamped coil and second stamped coil in co-planar relation,
the first stamped coil positioned within the second space of
the second stamped coil, and the second stamped coil
positioned within the first space of the first stamped coil, the
first and second coils electronically connected and an adhe-
sive covering and surrounding the first stamped coil and the
second stamped coil to bond the coils together and to
insulate the coils.

8 Claims, 17 Drawing Sheets

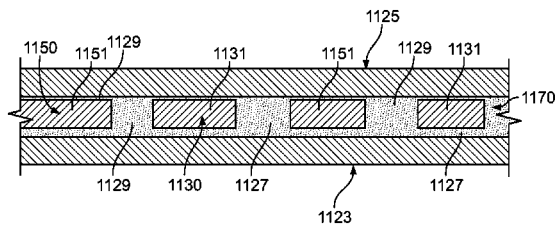
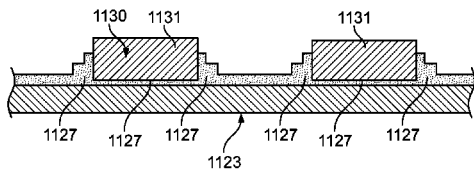

Related U.S. Application Data

- continuation-in-part of application No. 14/470,381, filed on Aug. 27, 2014.
- (60) Provisional application No. 61/908,573, filed on Nov. 25, 2013, provisional application No. 62/004,587, filed on May 29, 2014, provisional application No. 62/077,721, filed on Nov. 10, 2014.
- (51) **Int. Cl.**
H01F 38/14 (2006.01)
H01F 27/28 (2006.01)
H02J 7/00 (2006.01)
H04B 5/00 (2006.01)
H01F 27/36 (2006.01)
H02J 5/00 (2016.01)
- (52) **U.S. Cl.**
 CPC *H01F 27/2852* (2013.01); *H01F 27/2871* (2013.01); *H01F 38/14* (2013.01); *H02J 7/0042* (2013.01); *H04B 5/0037* (2013.01); *H04B 5/0087* (2013.01); *H01F 27/365* (2013.01); *H02J 5/005* (2013.01); *Y10T 29/4902* (2015.01)
- (58) **Field of Classification Search**
 USPC 336/65, 83, 200, 206–208, 232
 See application file for complete search history.

(56) **References Cited**

U.S. PATENT DOCUMENTS

5,831,348	A	11/1998	Nishizawa
6,180,433	B1	1/2001	Furey et al.
8,674,692	B2	3/2014	Camp
9,162,024	B2	10/2015	Pang et al.
2004/0231138	A1	11/2004	Kasahara et al.
2008/0048816	A1	2/2008	Matsumoto et al.
2008/0164967	A1	7/2008	Mashino
2011/0032065	A1	2/2011	Raczkowski
2011/0050382	A1	3/2011	Baarman et al.
2011/0102125	A1	5/2011	Tamura et al.
2012/0068708	A1	3/2012	Camp
2013/0015719	A1	1/2013	Jung et al.
2013/0120100	A1	5/2013	Muramatsu et al.
2013/0181668	A1	7/2013	Tabata et al.
2013/0187474	A1	7/2013	De Boodt
2013/0200974	A1	8/2013	Markowski et al.

2013/0260677	A1	10/2013	Partovi
2013/0307468	A1	11/2013	Lee et al.
2014/0021794	A1	1/2014	Kim et al.
2015/0145634	A1	5/2015	Kurz et al.
2015/0145635	A1	5/2015	Kurz et al.
2016/0163451	A1	6/2016	Wang

FOREIGN PATENT DOCUMENTS

GB	2369251	A	5/2004
TW	201015592	A	4/2010
WO	2013/046533	A1	4/2013

OTHER PUBLICATIONS

PCT Written Opinion of the International Searching Authority dated Feb. 26, 2015, issued in connection with International Application No. PCT/US14/67440 (5 pages).

International Search Report of the International Searching Authority dated Dec. 17, 2014, issued in connection with International Application No. PCT/US14/53151 (3 pages).

PCT Written Opinion of the International Searching Authority dated Dec. 17, 2014, issued in connection with International Application No. PCT/US14/53151 (5 pages).

Office Action dated Mar. 15, 2016, issued in connection with U.S. Appl. No. 14/553,617 (6 pages).

Office Action dated Apr. 14, 2016, issued in connection with U.S. Appl. No. 14/470,381 (8 pages).

Office Action dated Oct. 7, 2015, issued in connection with U.S. Appl. No. 14/470,381 (7 pages).

Notice of Allowance dated Jul. 5, 2016, issued in connection with U.S. Appl. No. 14/553,617 (7 pages).

Office Action dated Aug. 10, 2016, issued in connection with U.S. Appl. No. 14/470,381 (9 pages).

Extended European Search Report dated Jun. 7, 2017, issued by the European Patent Office in connection with European Patent Application No. EP14863209.4 (5 pages).

Office Action, along with its English translation, dated Apr. 25, 2017, issued by the State Intellectual Property Office of China in connection with Chinese Patent Application No. CN102084440 (13 pages).

Office Action dated Apr. 18, 2017, issued in connection with U.S. Appl. No. 14/470,381 (16 pages).

Office Action, along with its English translation, dated Nov. 6, 2017, issued by the Chinese Patent Office in connection with Chinese Patent Application No. 201480074077.1 (10 pages).

Office Action dated Sep. 26, 2017, issued by the Taiwan Patent Office in connection with Taiwan Patent Application No. 103140754, along with English translation (9 pages).

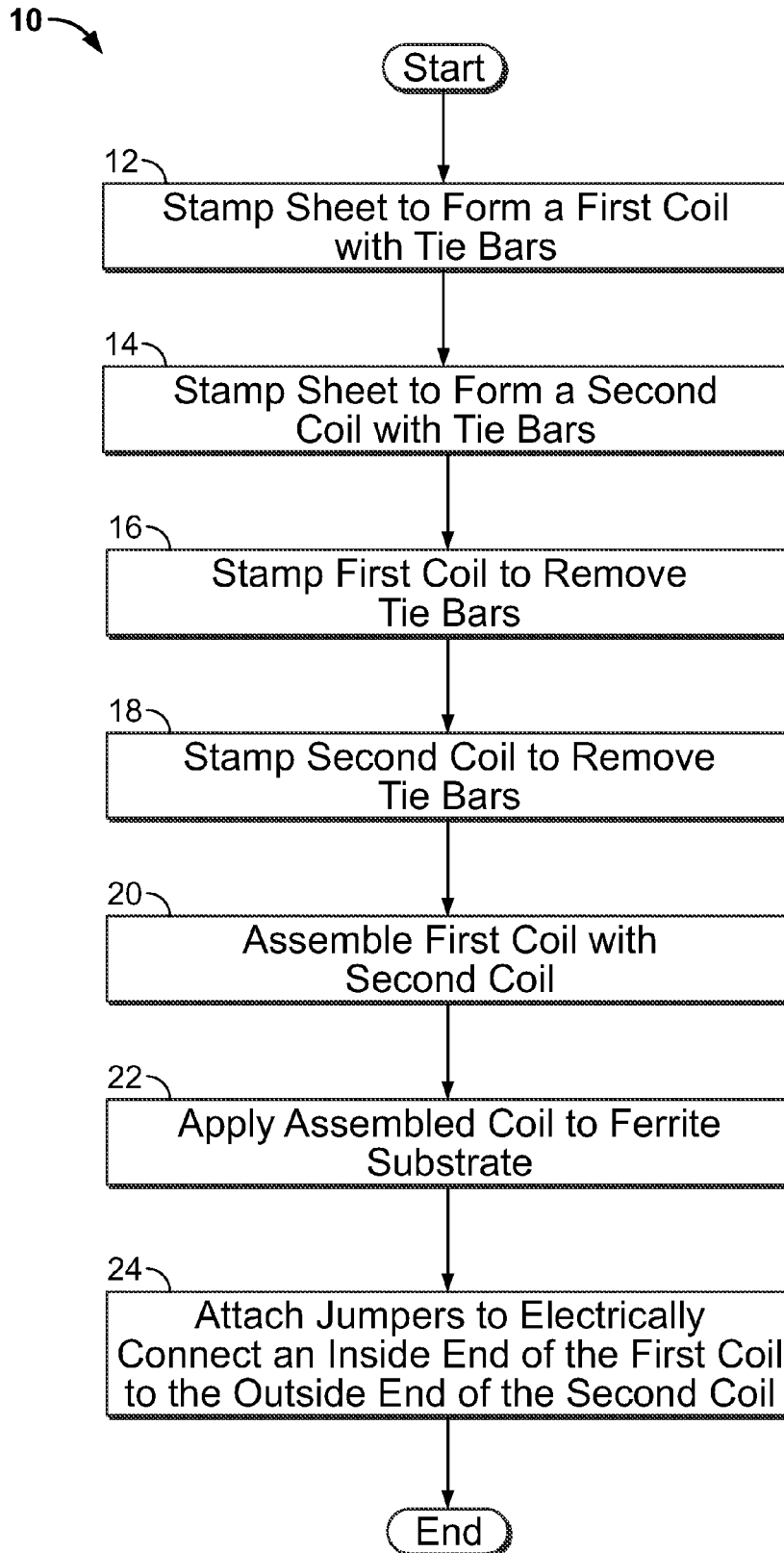

FIG. 1

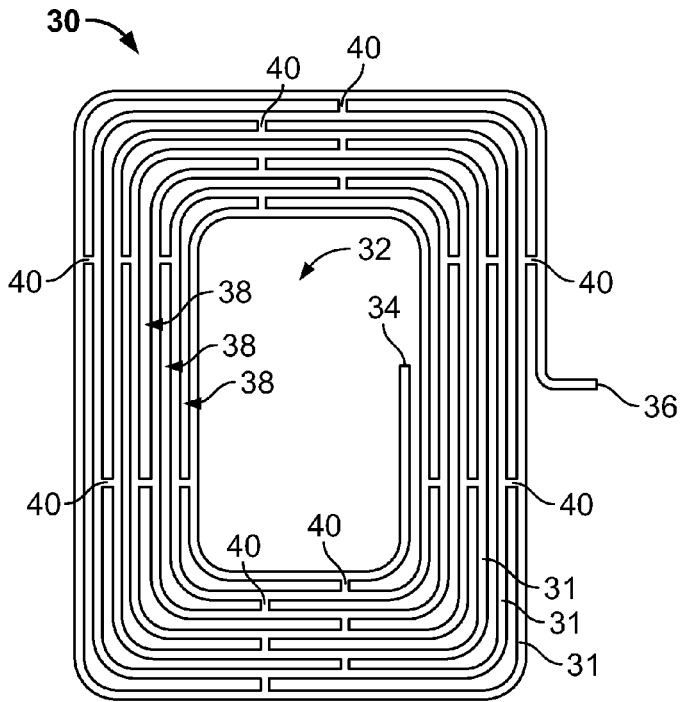

FIG. 2

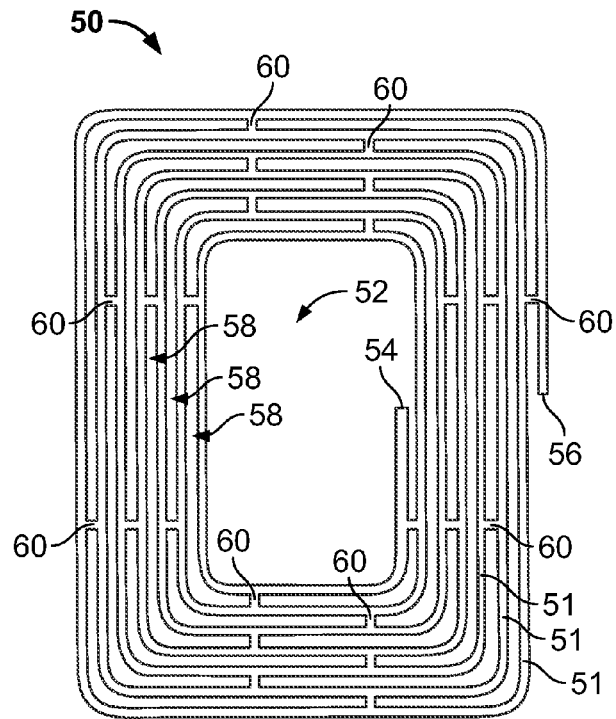

FIG. 3

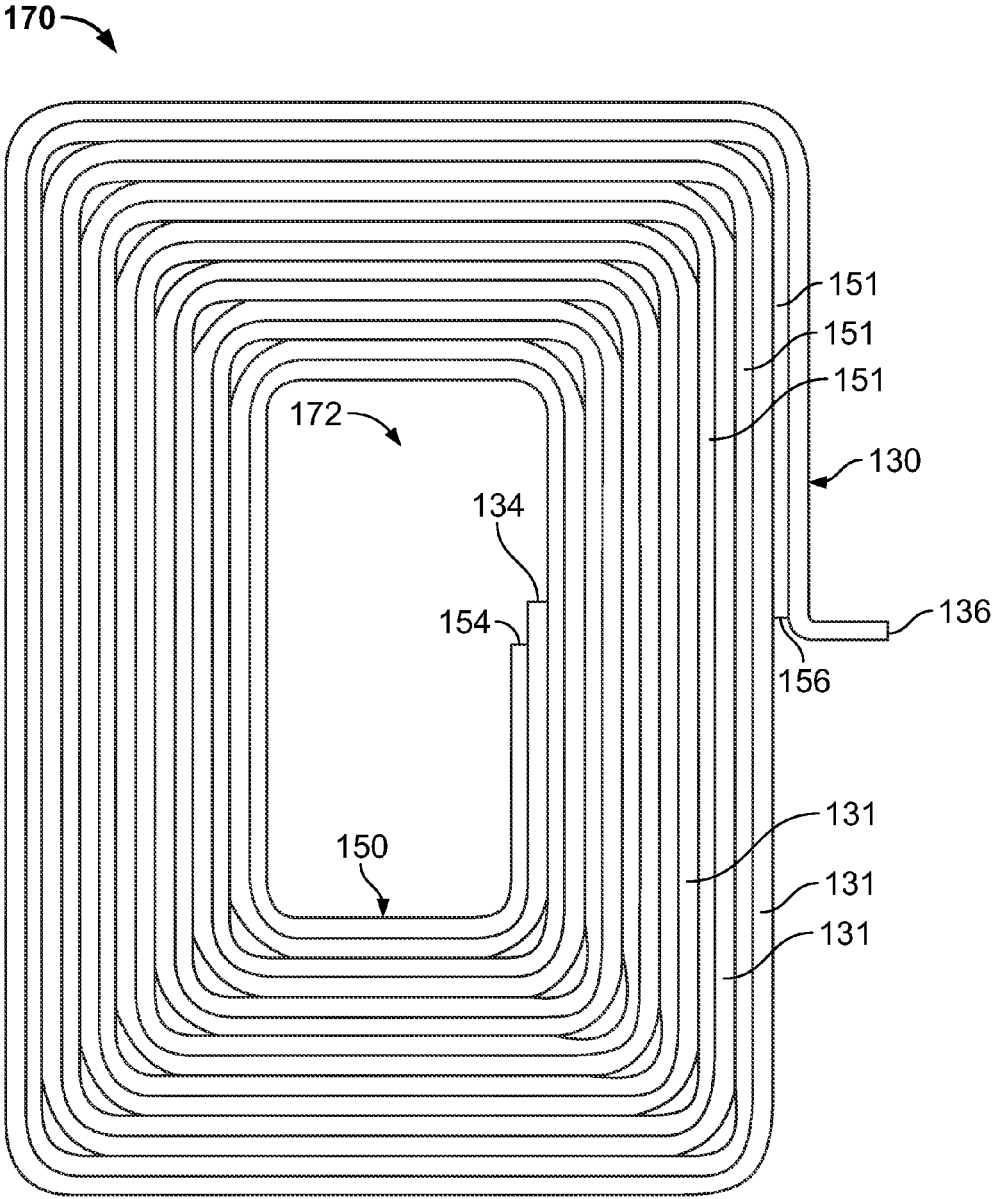

FIG. 4

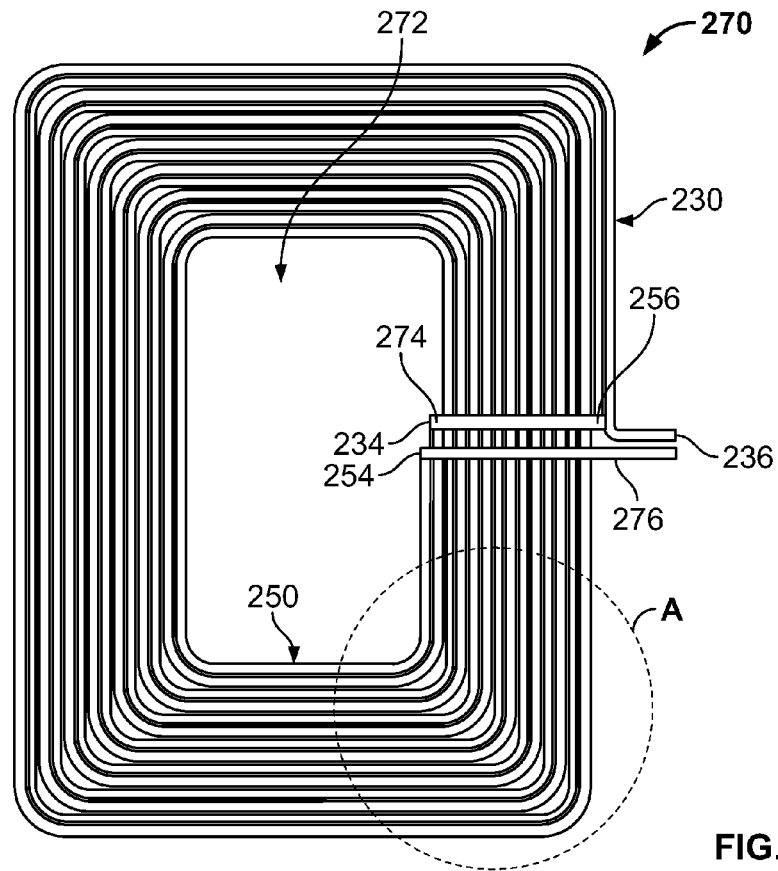

FIG. 5

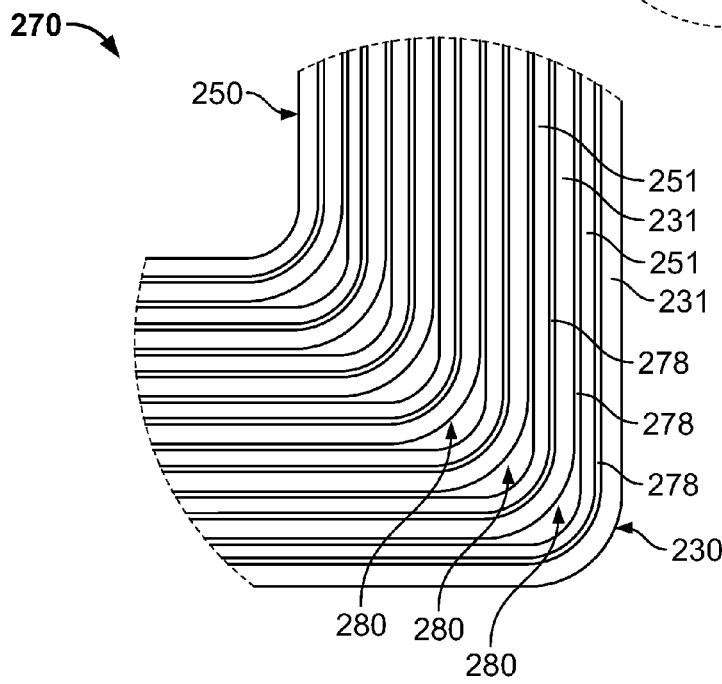

FIG. 6

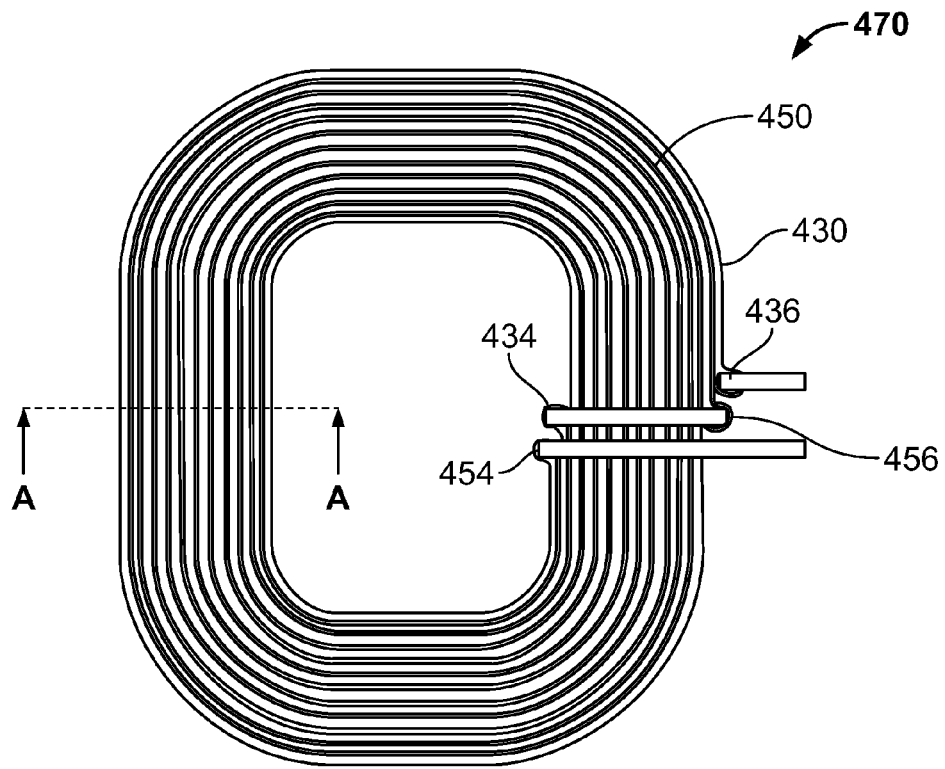

FIG. 8

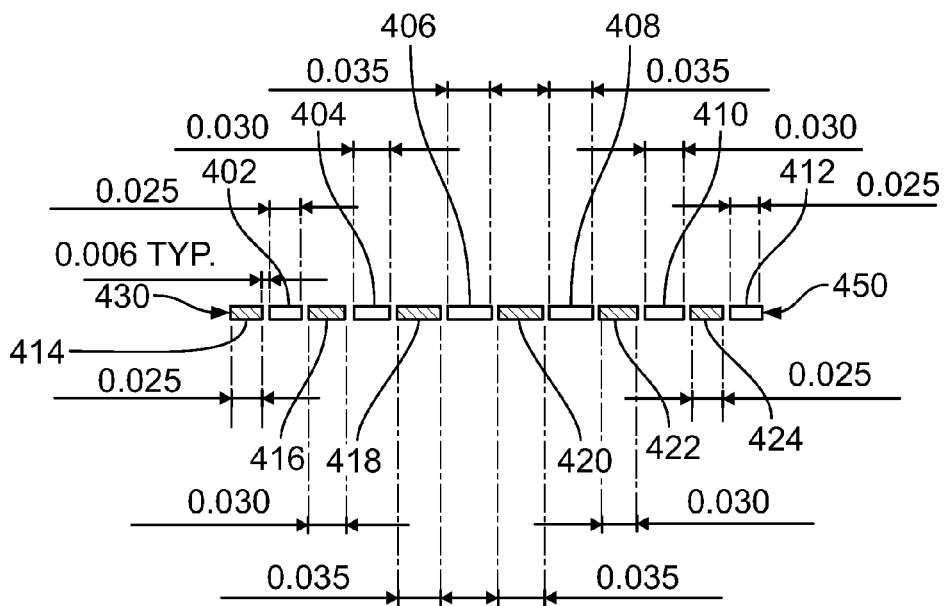

FIG. 9

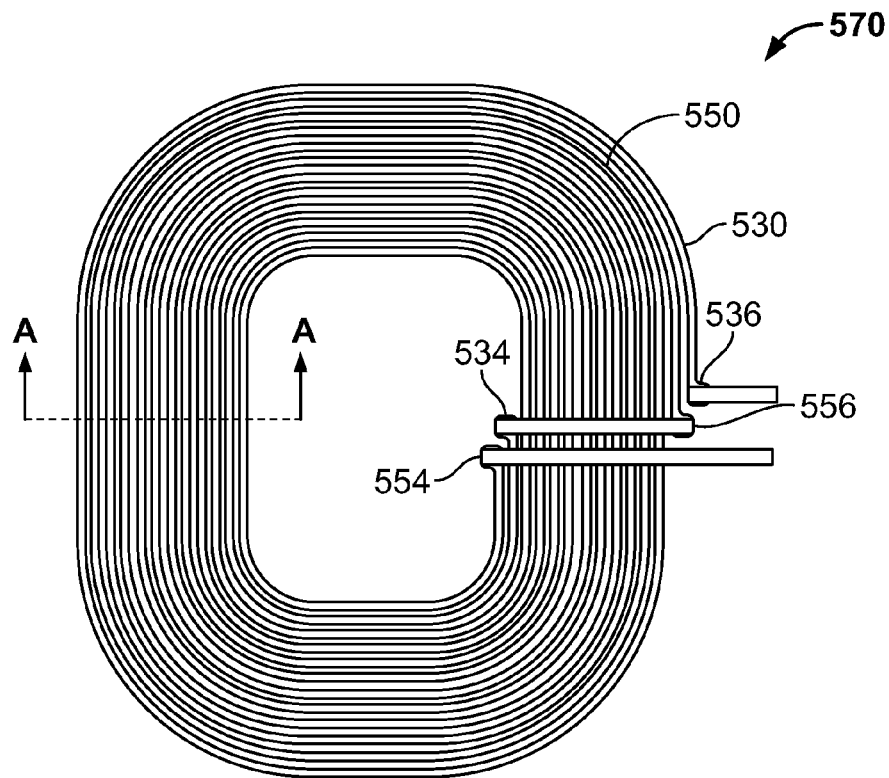

FIG. 10

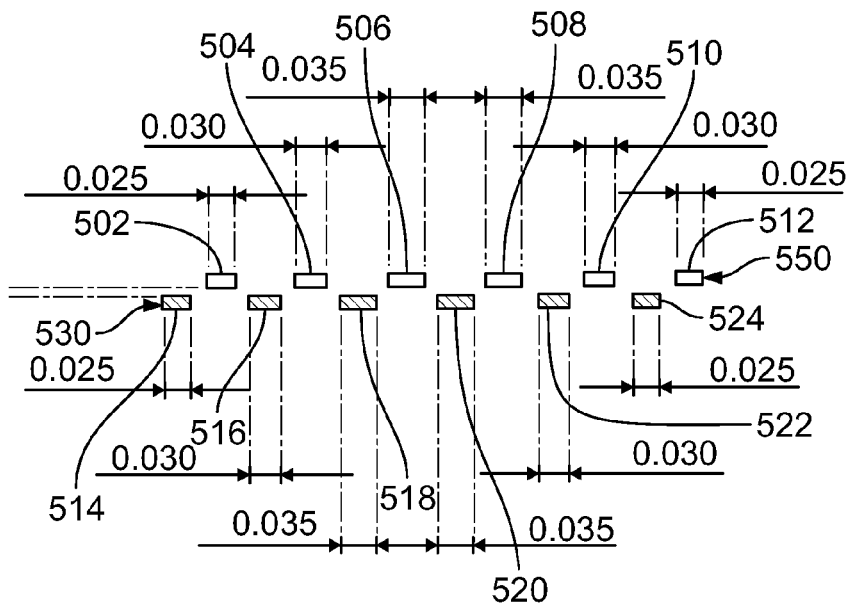

FIG. 11

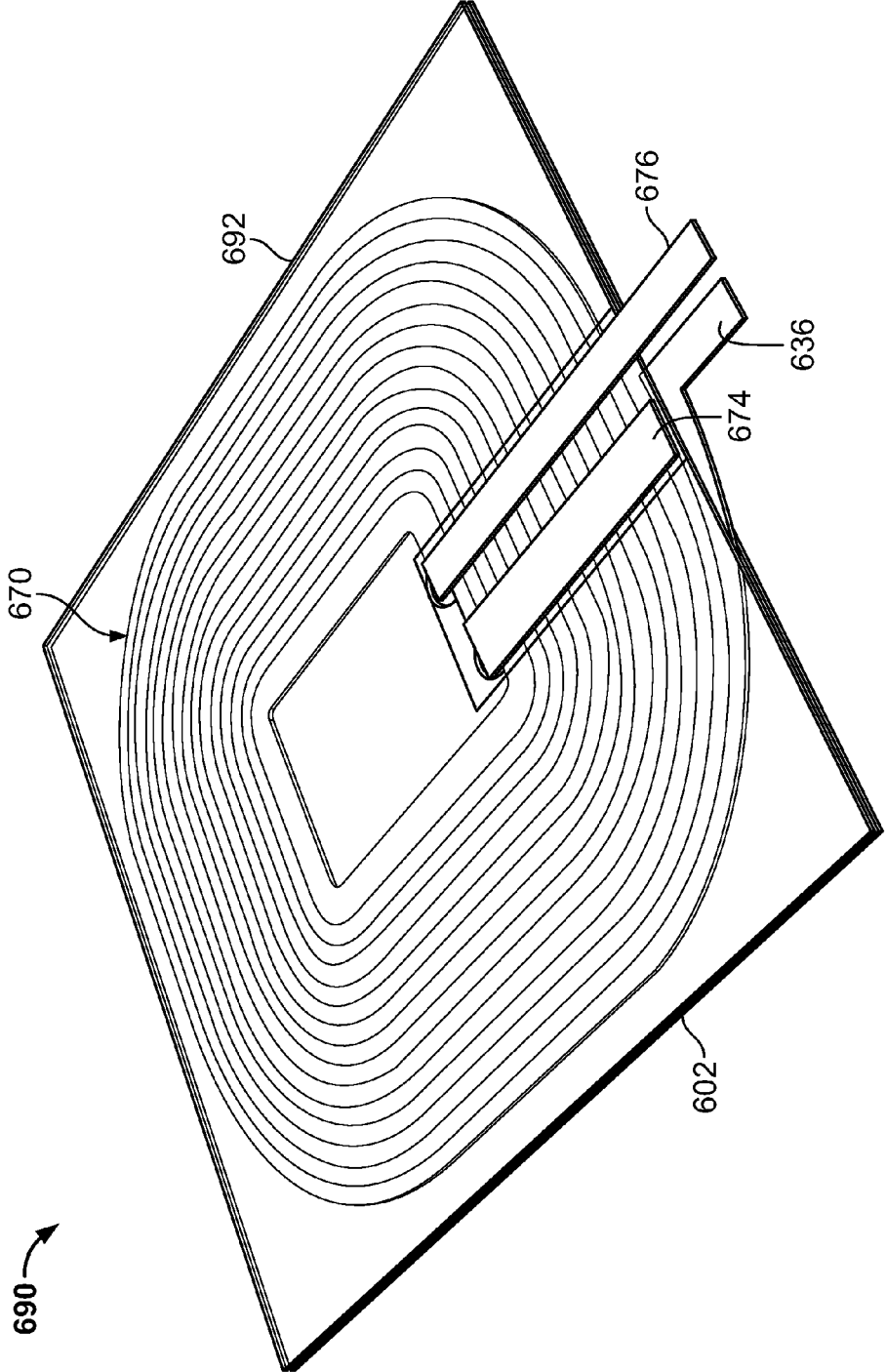

FIG. 12

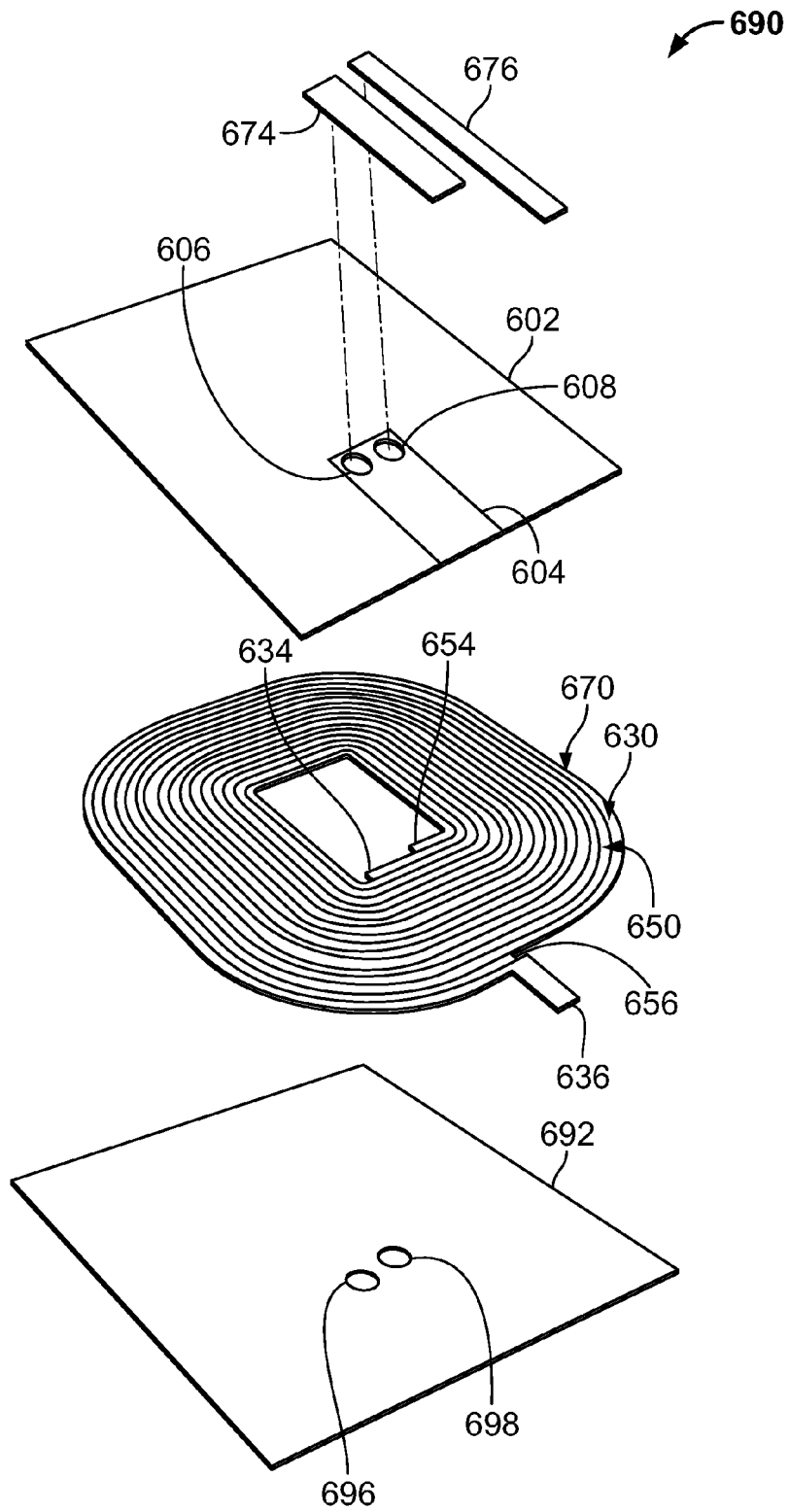

FIG. 13

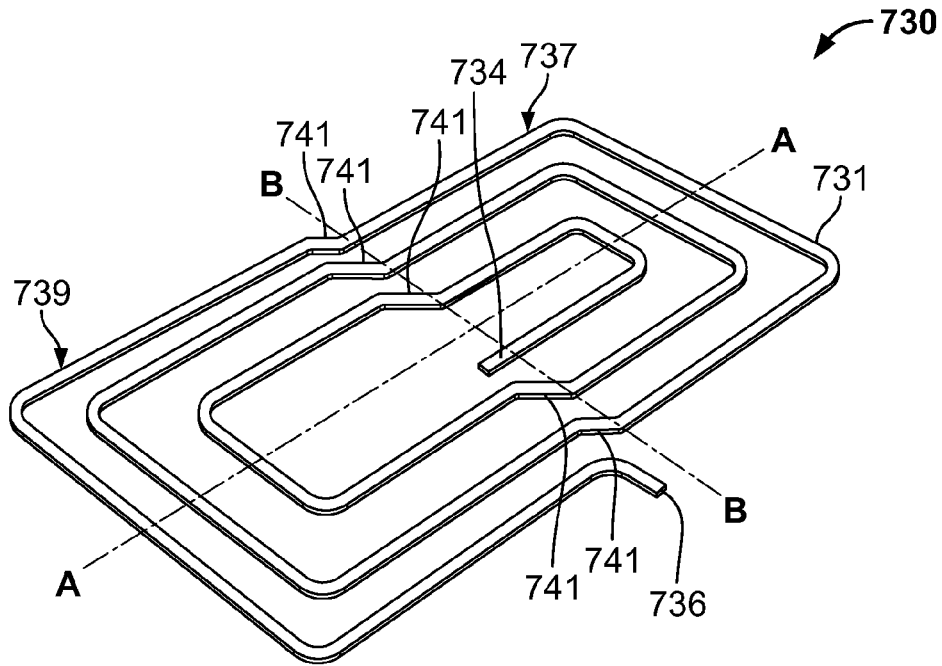

FIG. 14

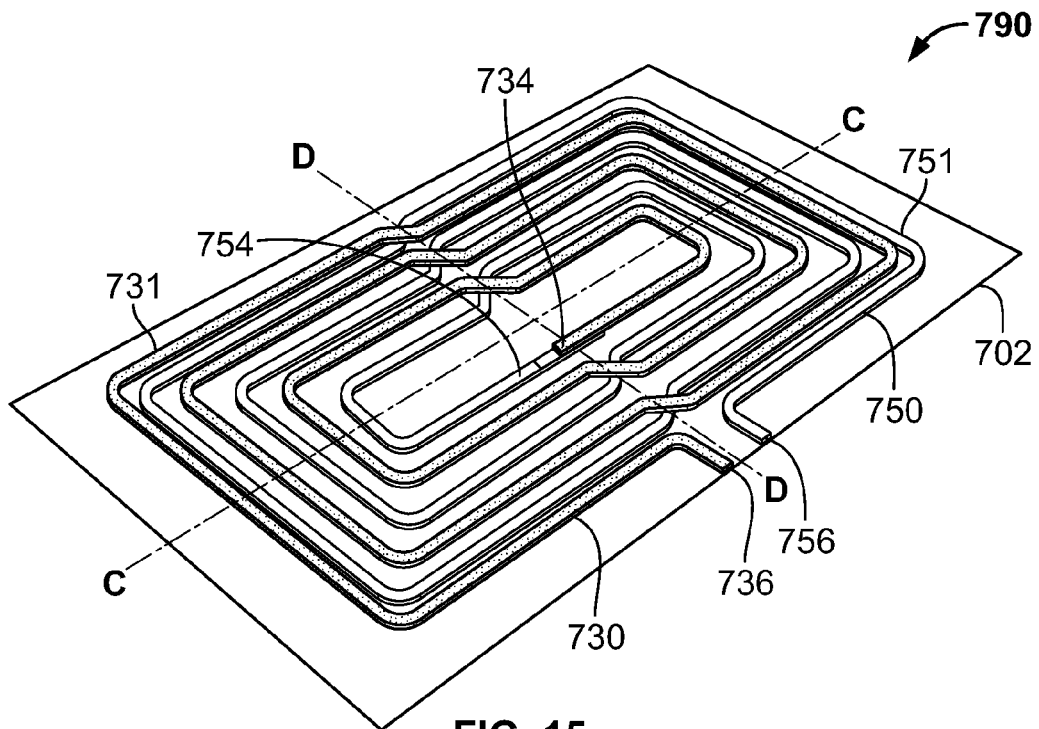

FIG. 15

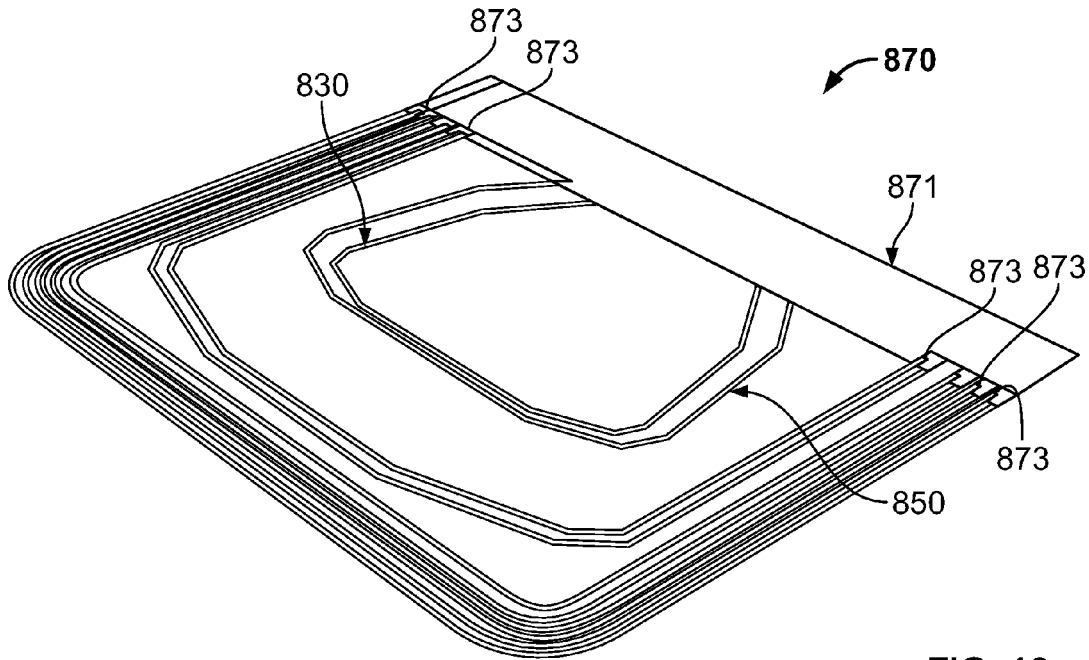

FIG. 16

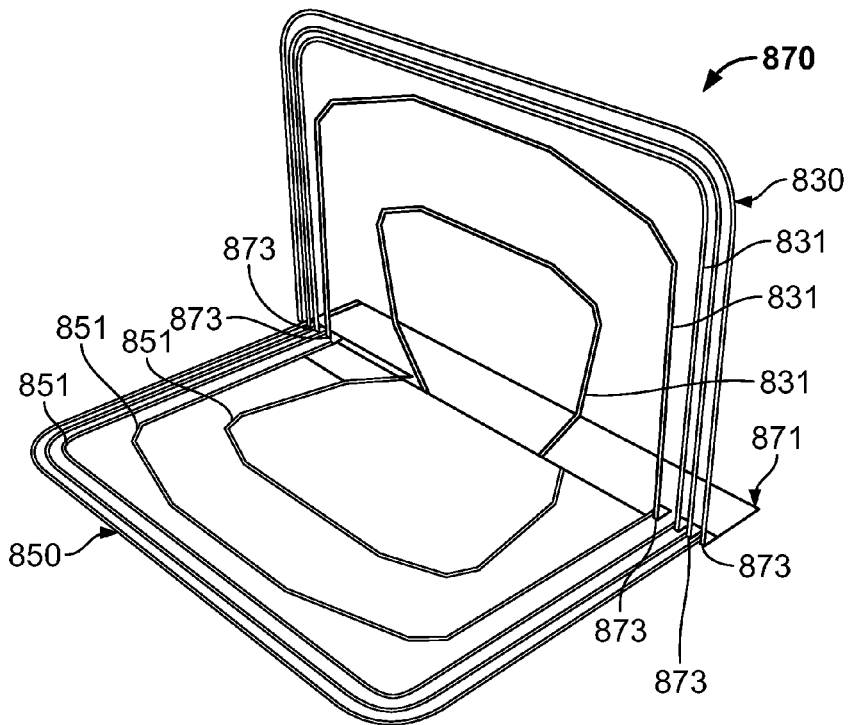

FIG. 17

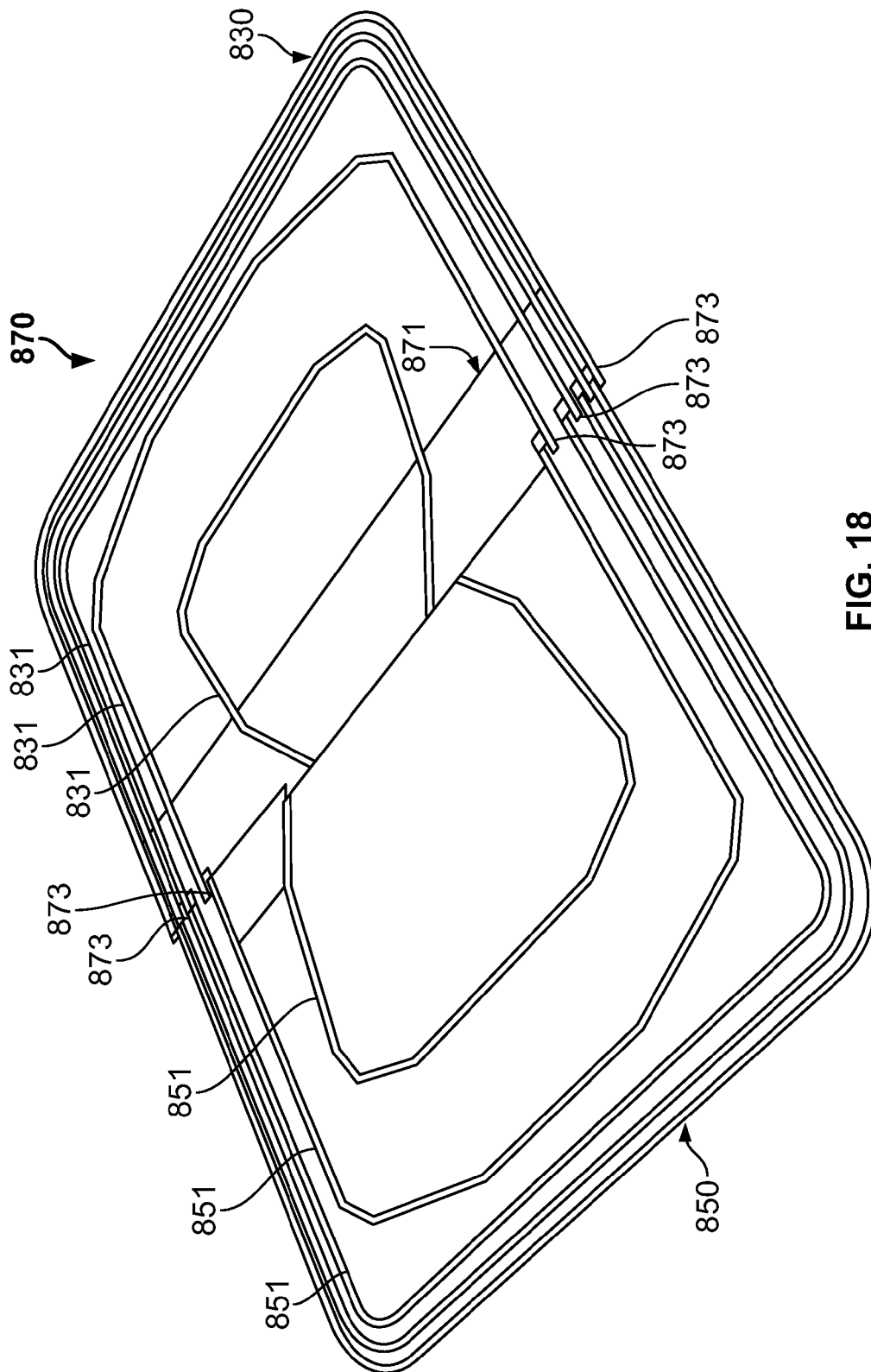

FIG. 18

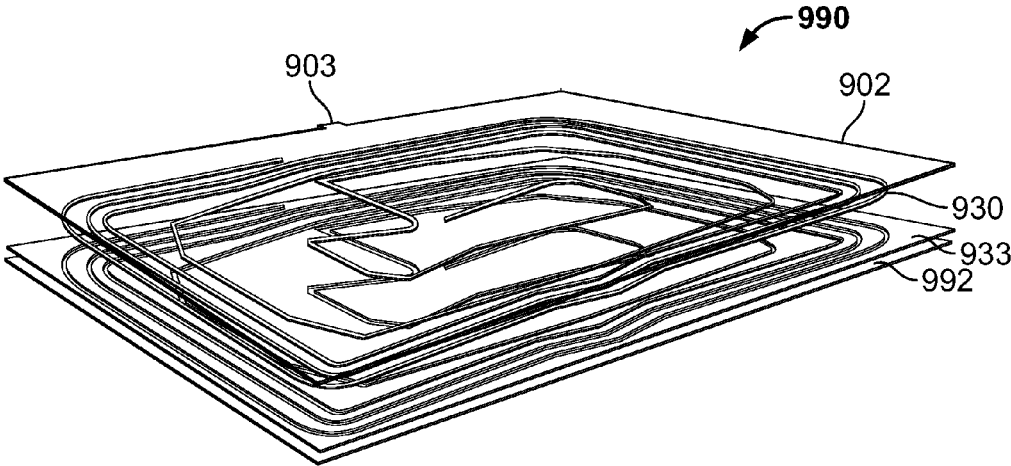

FIG. 19

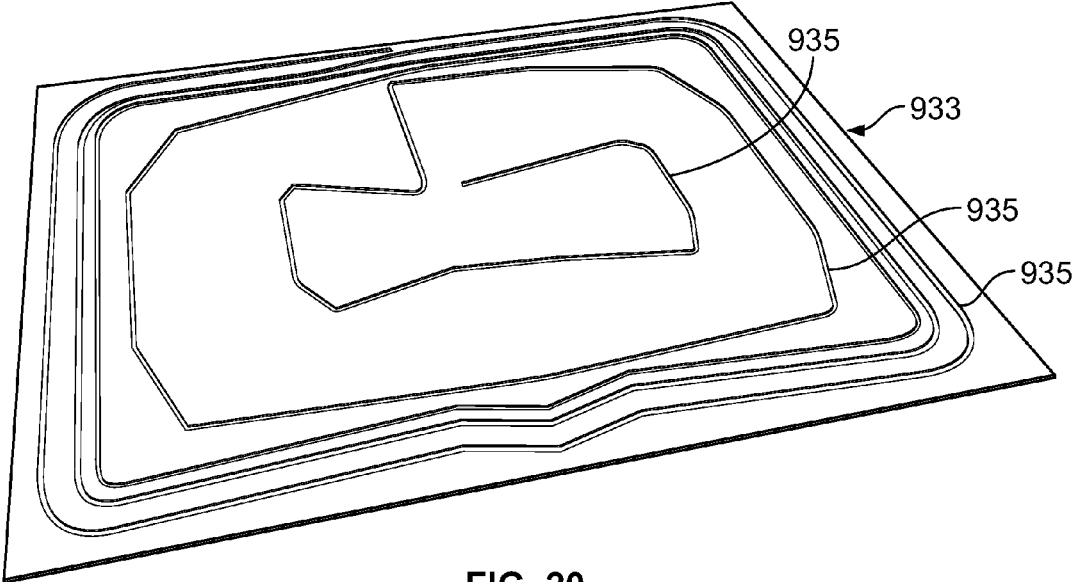

FIG. 20

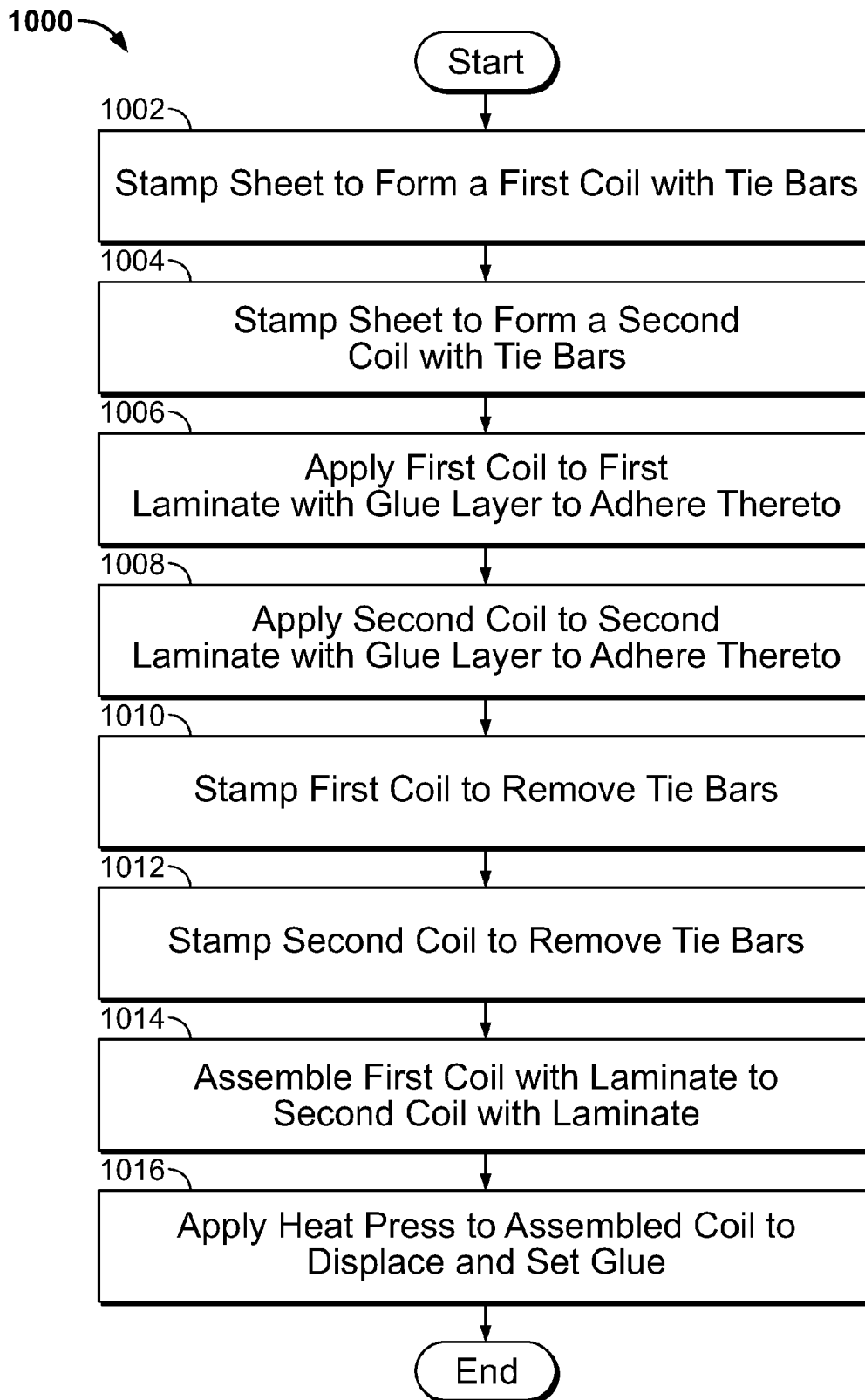

FIG. 21

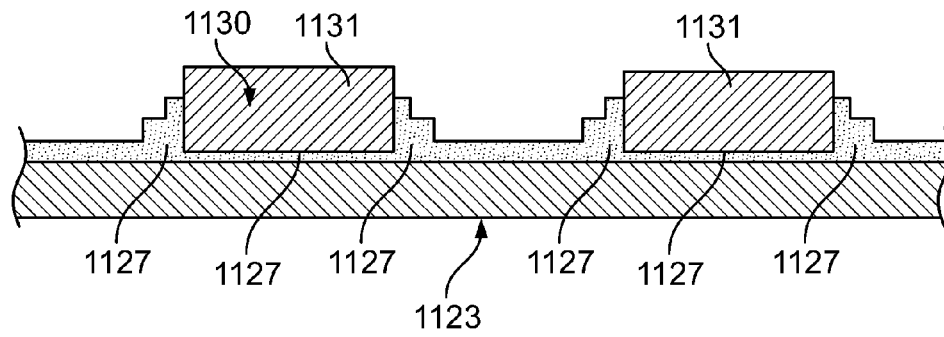

FIG. 22

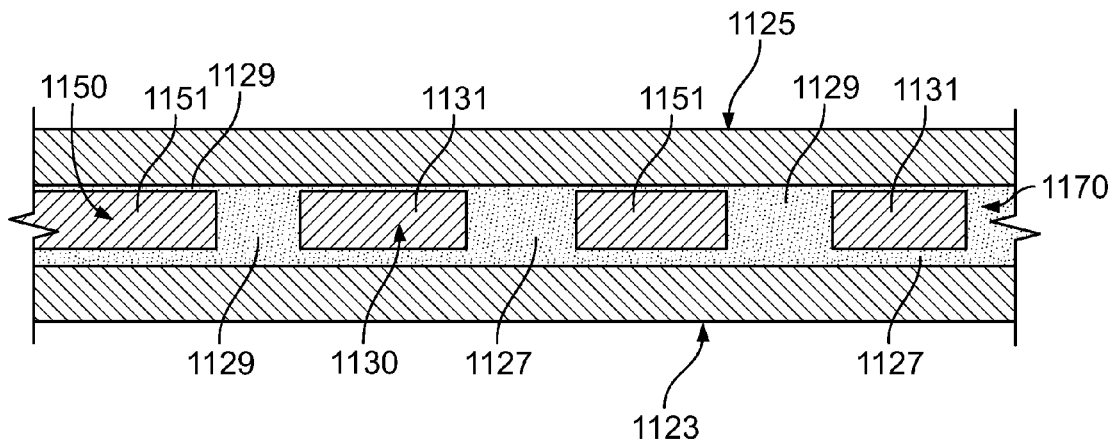

FIG. 23

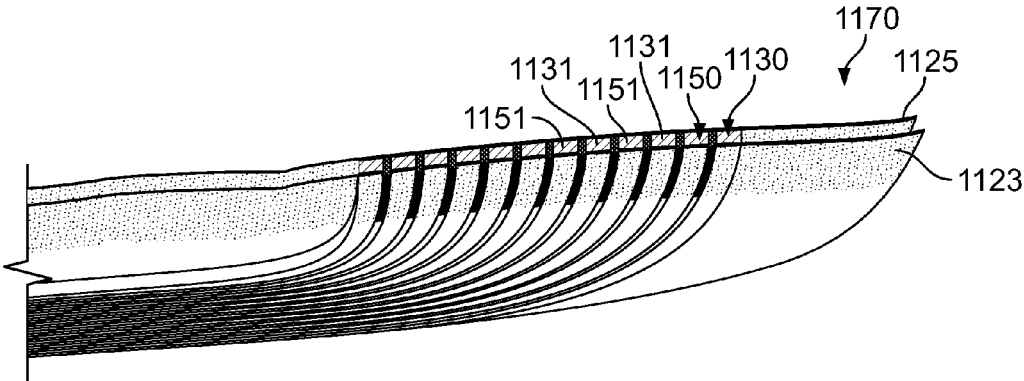

FIG. 24

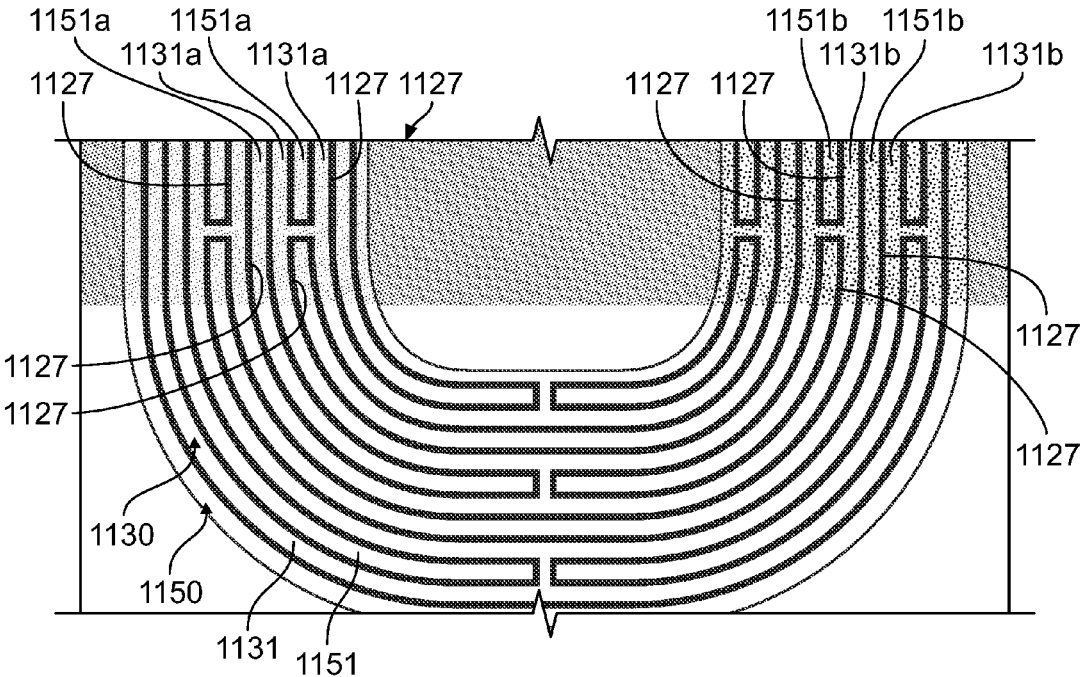

FIG. 25

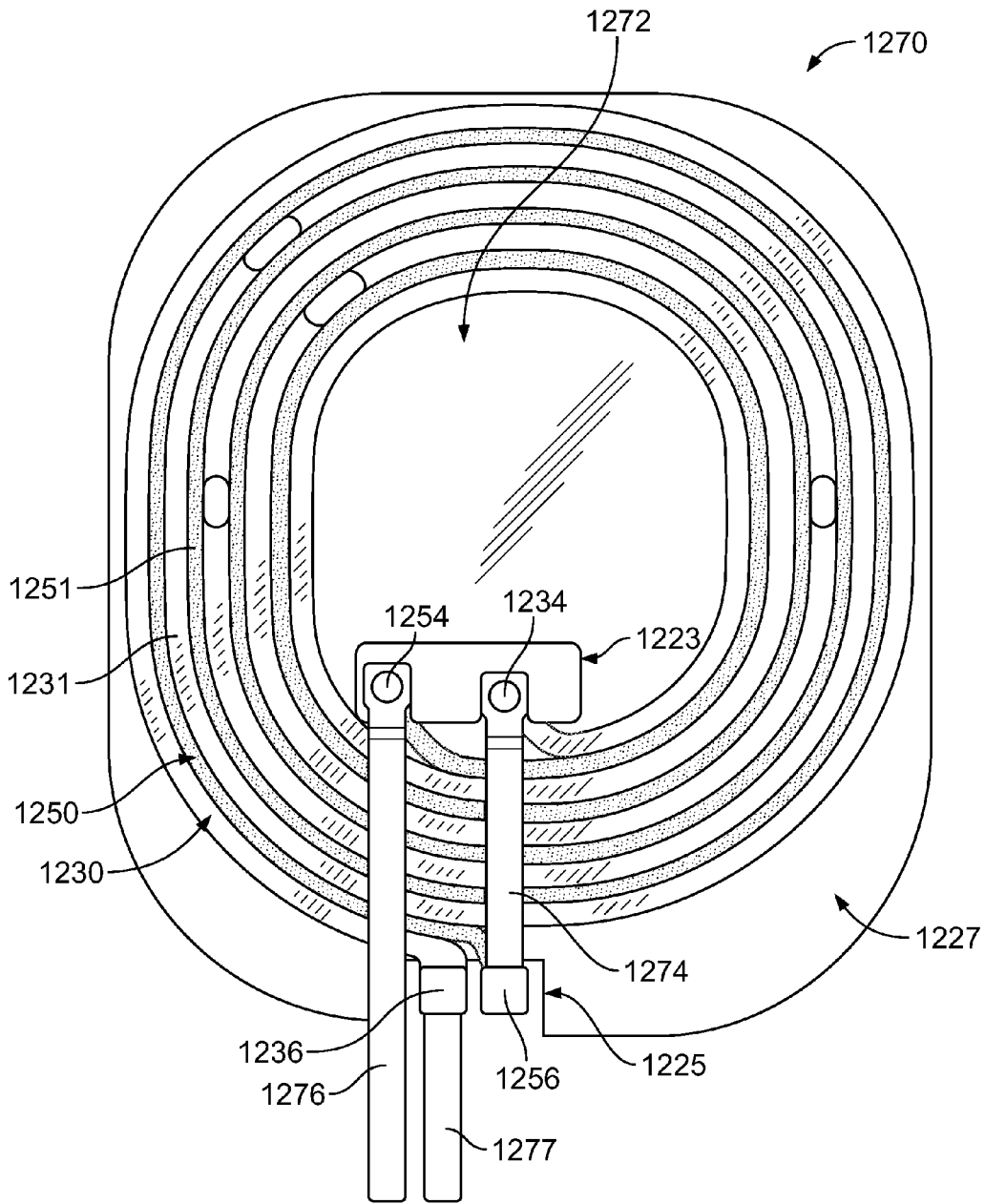

FIG. 26

1

WIRELESS CHARGING COIL**CROSS-REFERENCE TO RELATED APPLICATIONS**

This application is a Continuation Application of, and claims priority to, U.S. Non-Provisional patent application Ser. No. 14/553,617, filed Nov. 25, 2014, which is Continuation-In-Part (CIP) of, and claims priority to, U.S. Non-Provisional patent application Ser. No. 14/470,381, filed Aug. 27, 2014, which claims the benefit of U.S. Provisional Patent Application No. 61/908,573 filed on Nov. 25, 2013, and U.S. Provisional Patent Application No. 62/004,587 filed on May 29, 2014. U.S. Non-Provisional patent application Ser. No. 14/553,617, filed Nov. 25, 2014 also claims priority to U.S. Provisional Patent Application No. 61/908,573 filed on Nov. 25, 2013, U.S. Provisional Patent Application No. 62/004,587 filed on May 29, 2014, and U.S. Provisional Patent Application No. 62/077,721, filed on Nov. 10, 2014, the entire disclosures of which are expressly incorporated herein by reference.

BACKGROUND**Field of the Disclosure**

The present disclosure relates to a wireless charging coil and methods for manufacturing thereof. More specifically, the present disclosure relates to a bifilar parallel wound, series connected wireless charging coil.

Related Art

Wireless power transfer is the transfer of electrical power from a base station (transferring power) to a mobile device (consuming power) through electromagnetic induction (inductive power) and/or resonant frequency method. Wireless power transfer is becoming increasingly popular in mobile devices, and particularly in smartphones. A popular standard for inductive charging technology is the Qi interface standard developed by the Wireless Power Consortium, which has several protocols to allow the wireless transfer of electrical power between electronic devices. Other standards may make use of electromagnetic induction or resonant frequency to wirelessly charge devices. A mobile device (or any other electronic device) must meet certain requirements and performance standards in order to be Qi compliant.

Consumers generally want their mobile devices to be small and thin but also powerful and efficient, which are often counteracting goals. More specifically, charging coils must vary the material thickness to lower resistance and increase efficiency. Further, maximizing these goals can lead to performance and manufacturing limitations.

What would be desirable, but has not yet been developed, is a thinner and more efficient wireless charging coil for wireless power transfer between electronic devices.

SUMMARY

The present disclosure relates to wireless charging coils and methods for making thereof. More specifically, the present disclosure relates to a planar bifilar parallel-wound, series connected wireless charging coil. The coil has a thinner thickness (e.g., low profile), an increased density (e.g., high fill factor), and higher efficiency (e.g., lower resistance) than conventional wireless charging coils.

BRIEF DESCRIPTION OF THE DRAWINGS

The foregoing features of the disclosure will be apparent from the following Detailed Description, taken in connection with the accompanying drawings, in which:

2

FIG. 1 is a diagram showing processing steps for manufacturing a wireless charging coil;

FIG. 2 is a schematic view of a first stamped coil with tie bars;

5 FIG. 3 is a schematic view of a second stamped coil with tie bars;

FIG. 4 is a schematic view of an assembled coil after the tie bars of the first and second stamped coils have been removed;

10 FIG. 5 is a schematic view of the assembled wireless charging coil with jumpers attached;

FIG. 6 is a close up view of portion A of FIG. 5;

15 FIG. 7 is a schematic view of an electrical component assembly including a wireless charging coil and NFC antenna;

FIG. 8 is a schematic view of an assembled wireless charging coil with planar bifilar coils;

FIG. 9 is a cross-sectional view of a portion of the wireless charging coil of FIG. 8;

20 FIG. 10 is a schematic view of an assembled wireless charging coil with stacked bifilar coils;

FIG. 11 is a cross-sectional view of a portion of the wireless charging coil of FIG. 10;

25 FIG. 12 is a perspective view of an electrical component assembly;

FIG. 13 is an exploded view of the electrical component assembly of FIG. 12

FIG. 14 is a perspective view of a resonant coil;

FIG. 15 is a perspective view of a resonant coil assembly;

30 FIG. 16 is a perspective view of a folded stamped resonant coil;

FIG. 17 is a perspective view of the coil of FIG. 16 partially opened;

35 FIG. 18 is a perspective view of the coil of FIG. 16 fully opened;

FIG. 19 is an exploded view of a low profile electrical component assembly; and

FIG. 20 is a perspective view of the filler material of FIG. 19;

40 FIG. 21 is a diagram showing processing steps for manufacturing a wireless charging coil with adhesive;

FIG. 22 is a partial cross-sectional view of a first stamped coil when applied to a first laminate;

45 FIG. 23 is a partial cross-sectional view of an assembled coil positioned between a first and second laminate;

FIG. 24 is partial cross-sectional view of an assembled coil;

FIG. 25 is a partial top view of the assembled coil of FIG. 24; and

50 FIG. 26 is a top view of an assembled coil of the present disclosure.

DETAILED DESCRIPTION

55 The present disclosure relates to a wireless charging coil and methods of making same. As discussed in more detail below in connection with FIGS. 1-7, the stamped metal wireless charging coil comprises a series of parallel traces connected in a bifilar fashion. In other words, the wireless charging coil includes first and second coils that are parallel, closely spaced, and connected in series such that the first and second coils have parallel currents. The first and second coils could be stacked or planar and connected in series and/or parallel to meet performance requirements (e.g., electrical requirements, power requirements, etc.). The wireless charging coil could be used in any battery powered device, particularly in mobile devices (e.g., smartphones,

3

tablets, watches, etc.). The wireless charging coil can be made to be Qi compliant, but could be adjusted to comply with any wireless transfer protocol. A wireless charging coil with a greater amount of conductive material, such as copper, can be positioned within a given space by varying (e.g., increasing) the thickness of the coil, which increases energy availability. Compared with other wireless charging coils, the wireless charging coils described herein exhibit an increased magnetic coupling effectiveness (e.g., magnetic field strength) and thereby transmit energy at a higher efficiency.

FIG. 1 is a diagram showing processing steps 10 for manufacturing a wireless charging coil of the present disclosure. In step 12, a metal sheet is stamped to form a first coil with tie bars. The metal sheet could be any of a variety of materials suitable for wireless power transfer (e.g., copper, copper alloy, aluminum, aluminum alloy, etc.). In step 14, a metal sheet (e.g., the same metal sheet or a different metal sheet) is stamped to form a second coil with tie bars. In step 16, the first coil is stamped to remove the tie bars. In step 18, the second coil is stamped to remove the tie bars. In step 20, the first and second coils are assembled together. In step 22, the assembled coil is applied to a ferrite substrate. In step 24, jumpers (e.g., leads) are attached to electrically connect the first and second coils in series (e.g., an inside end of the first coil is electrically connected to the outside end of the second coil via a jumper).

The steps described above could be interchanged, consolidated, or omitted completely. For example, the coils could be stamped without first forming tie bars, and/or the first and second coils could be applied directly to the ferrite (without being assembled first), etc. Additionally, the coil could be photo-chemically etched or machined instead of stamped, or made by any other suitable manufacturing process.

FIG. 2 is a view of a first stamped coil 30 with tie bars. The first coil 30 can be a generally rectangular planar spiral trace 31, although the trace 31 could form any suitable shape (e.g., circular planar spiral). The dimensions of the coil 30 could vary depending on the application of the coil 30 (e.g., as used in mobile devices, wearable devices, cars, etc.). The coil 30 could be of any suitable thickness, such as between 0.003 in. and 0.020 in., etc., but could be thicker for higher powered applications. The coil 30 could be of any suitable overall dimensions, such as between 0.25 in. and 4 in. in width and/or between 0.25 in. and 4 in. in height. The trace 31 could also be of any suitable dimensions. For example, the trace 31 could be between 0.005 in. and 0.250 in. in width. The dimensions could vary depending on physical and performance requirements of the mobile device (e.g., required frequency). The coil 30 could be made of any suitable material for wireless power transfer, such as, for example, copper, copper alloy, aluminum, aluminum alloy, tempered copper alloy (e.g., C110), etc.

The trace 31 of the coil 30 revolves around a center any number of times (e.g., 5, 10, etc.), such as to comply with any inductive or resonant power requirements. The trace 31 spirals to form an inside portion 32 at the center of the coil 30. As a result, the coil 30 has an inside end 34 and an outside end 36. The spaces 38 between the trace 31 are configured to be wide enough (e.g., 0.0285 in.) to accommodate the second stamped coil (described in more detail below). Tie bars 40 can be positioned at a plurality of locations throughout these spaces 38 to maintain the general shape of the coil 30 (e.g., prevent unwinding or deformation of the shape), such as during transportation of the coil 30 between locations or between stations. The outside end 36

4

could extend out at an angle, such as a generally ninety degree angle. The inside end 34 and outside end 36 can be disposed towards the same side of the coil 30, but could be at any of a variety of locations in the coil 30.

FIG. 3 is a view of a second stamped coil 50 with tie bars. The second coil 50 shares most of the same features and characteristics of the first coil shown in FIG. 2. The second coil 50 can be a generally rectangular planar spiral trace 51, although the trace 51 could form any suitable shape (e.g., circular planar spiral). The dimensions of the coil 50 could vary depending on the application of the coil 50 (e.g., as used in mobile devices, wearable devices, cars, etc.). The coil 50 could be of any suitable thickness, such as between 0.003 in. and 0.020 in., etc., but could be thicker for higher powered applications. The coil 50 could be of any suitable overall dimensions, such as between 0.25 in. and 4 in. in width and/or between 0.25 in. and 4 in. in height. The trace 51 could also be of any suitable dimensions. For example the trace 51 could be between 0.005 in. and 0.250 in. in width. The dimensions could vary depending on physical and performance requirements of the mobile device (e.g., required frequency). The coil 50 could be made of any suitable material for wireless power transfer, such as, for example, copper, copper alloy, aluminum, aluminum alloy, tempered copper alloy (e.g., C110), etc.

The trace 51 of the coil 50 revolves around a center any number of times (e.g., 5, 10, etc.), such as to comply with any inductive or resonant power requirements. The trace 51 spirals to form an inside portion 52 at the center of the coil 50. As a result, the coil 50 has an inside end 54 and an outside end 56. The spaces 58 between the trace 51 are configured to be wide enough (e.g., 0.0285 in.) to accommodate the first stamped coil 30 (described above). Tie bars 60 can be positioned at a plurality of locations throughout these spaces 58 to maintain the general shape of the coil 50 (e.g., prevent unwinding or deformation of the shape), such as during transportation of the coil 50 between locations or between stations. The outside end 56 does not extend out as with the first coil 30 (but could). The inside end 54 and outside end 56 can be disposed towards the same side of the coil 50, but could be at any of a variety of locations in the coil 50.

FIG. 4 is a view of an assembled coil 170 after the tie bars of the first and second stamped coils 130, 150 have been removed. As shown, the first and second coils 130, 150 fit into each other. More specifically, the first coil 130 fits into the space formed between the trace 151 of the second coil 150, and conversely, the second coil 150 fits into the space formed between the trace 131 of the first coil 130. However, when assembled, there are small gaps between the trace 131 of the first coil 130 and the trace 151 of the second coil 150 (e.g., 0.003 in., 0.004 in., etc.), as discussed below in more detail. As a result, together the first and second coils 130, 150 together form a parallel planar spiral. Also shown, the inside end 134 of the first coil 130 is adjacent to the inside end 154 of the second coil 150, and the outside end 136 of the first coil 130 is adjacent to the outside end 156 of the second coil 150. However, the ends could be any relative distance from one another. This stamping method could have an average space width variation of at least approximately 0.003 in. for the assembled coil 170. The maximum and minimum variance are dependent on the assembled coil 170 dimensions (e.g., overall height and width).

The tight tolerances and rectangular cross-sectional shape of the traces 130, 131 could result in a fill ratio (e.g., 85%) greater than current industry coils (e.g., 65%), such as wound coils, etched coils, etc. For example, the rectangular

5

cross-sectional shape achieved from stamping (see FIG. 9 below) provides a potentially greater fill ratio than the circular cross-sectional shape of a round wire (e.g., round copper wire). More specifically, a 0.010 in. diameter insulated round wire (0.009 diameter in. wire with 0.0005 in. insulation) could provide a 65% fill ratio, compared to a stamped coil with a rectangular cross section having a 0.006 thickness and 0.003 spacing gap. Further, the wireless charging coil 170 can operate under higher ambient temperatures than other current industry wires (e.g., Litz wire), and is not susceptible to degradation by vibration, shock, or heat. This is partly because the wireless charging coil 170 is made of a single-monolithic conductor (e.g., not a multi-strand wire). This can be compared to the individual strands of a Litz wire, which has insulation material separating each of the individual wire strands which cannot withstand higher temperatures.

FIG. 5 is a view of the assembled wireless charging coil 270 with jumpers attached. Although not shown, a jumper could be attached to the first outside end 236. As shown, the inside end 234 of the first coil 230 is electrically connected to the outside end 256 of the second coil 250 by a first jumper 274. These ends 234, 256 are relatively proximate to one another, and disposed on the same side of the coil 270 to allow for a short jumper 274. A second jumper 276 is then used to electrically connect the inside end 254 of the second coil with the mobile device circuitry. The outside end 236 and inside end 254 are relatively proximate and disposed towards the same side of the coil 270, to provide for a short jumper 276 and for ease of electrical wiring with the electronic device. The result is a pair of parallel, closely spaced coils 230, 250 connected in series such that the first and second traces 230, 250 have parallel currents (e.g., the currents of each trace are in the same clockwise or counter-clockwise direction).

When fully assembled with the other components of the electronic device, the inside portion 272 of the assembled coil 270 is insulated (e.g., by plastic and glue) to ensure proper performance. The assembled wireless charging coil 270 can have any number of windings, depending upon electrical requirements. The wireless charging coil 270 could be used in any battery powered device, such as smartphones. The assembled coil 270 could be of any suitable overall dimensions (e.g., 1.142 in. width and 1.457 in. height, etc.). The coil length could be of any suitable length (e.g., 48.459 in.).

FIG. 6 is a close up view of portion A of FIG. 5. As shown, there are very small gaps 278 (e.g., voids) between the trace 231 of the first coil 230 and the trace 251 of the second coil 250 (e.g., 0.003 in., 0.004 in., etc.), although there could be increased gaps 280 at the corners to account for the bends in the traces 231, 251 (e.g., such that the gap increase alternates). These tight tolerances could result in a fill ratio greater than current industry methods.

The assembled wireless charging coil 270 could provide direct current (DC) resistance (ohms), alternating current (AC) resistance, and/or AC/DC resistance ratios at a number of different values depending on the dimensions of the charging coil 270 and material(s) used in construction of the charging coil. The values could be adjusted to achieve high AC/DC ratios to meet induction standards. The coil dimensions could be varied to achieve varying resistance depending on the performance characteristics required. For example, for a resistance of 0.232 ohms using C110 alloy, the traces 230, 250 could have a cross section of 0.0001234 in.² (e.g., 0.005 in. thickness and 0.0246 in. width, or 0.004 in. thickness and 0.0308 in. width, etc.), and for a resistance

6

of 0.300 ohms using C110 alloy, the traces 230, 250 could have a cross section of 0.0000953 in.² (e.g., 0.005 in. thickness and 0.019 in. width, or 0.004 in. thickness and 0.0238 in. width, etc.). The stamped wireless charging coil 270 can achieve a high trace thickness and/or high overall aspect ratio compared to other current industry methods (e.g., printed circuit board (PCB) etched coils).

FIG. 7 is a view of an electrical component assembly 390 including a wireless charging coil 370. More specifically, the wireless charging coil 370 is attached to ferrite substrate 392 and in conjunction with a near field communication (NFC) antenna 394 having contact paddles. The wireless charging coil 370 and NFC antenna 394 could have contact pads (e.g., gold) to connect the wireless charging coil 370 and NFC antenna 394 to the circuitry of the mobile device. The assembly comprises a first jumper 374, a second jumper 376, and a third jumper 377 connecting the various ends of the coil 370, as explained above in more detail. There could be a film (e.g., clear plastic) over the wireless charging coil 370 and NFC antenna 394, with the jumpers 374, 376, 377 on top of the film and only going through the film at the points of connection. This prevents accidentally shorting any of the electrical connections of the coil 370. Alternatively, the jumpers 374, 376, 377 could be insulated so that a film is not needed. To minimize space, the wireless charging coil 370 is within the NFC antenna 394 with jumpers 376, 377 that extend to the outside of the NFC antenna 394. However, the wireless charging coil 370 and jumpers 376, 377 could be placed at any location relative to the NFC antenna 394.

The total thickness of the assembly could vary depending on various potential needs and requirements. For example, the jumpers could be 0.05-0.08 mm thick, the film could be 0.03 mm thick, the NFC antenna 394 and coil 370 could be 0.08 mm thick, and the ferrite 392 could be 0.2 mm thick for a total wireless charging coil thickness of approximately 0.36 mm.

FIG. 8 is a schematic view of an assembled wireless charging coil 470 with planar bifilar coils. As discussed above, the wireless charging coil 470 includes a first coil 430 (e.g., trace) and a second coil 450 (e.g., trace). The assembled coil 470 is manufactured and operates in the manner discussed above with respect to FIGS. 1-7. The first coil 430 and the second coil 450 can have any desired thickness, such as to meet different power requirements. The first coil 430 and second coil 450 could be connected in series or parallel.

The width of the first and/or second coil 430, 450 could vary along the length of the coil to optimize performance of the assembled wireless charging coil 470. Similarly, the thickness of the first and second coils 430, 450 could change over the length of the coil. For example, the width (and/or thickness) of the first coil 430 could gradually increase (or narrow) from a first end 434 towards a middle of the coil 430, and the width (and/or thickness) could likewise gradually narrow (or increase) from the middle to the second end 436 of the coil 430 (e.g., a spiral coil of wide-narrow-wide), thereby varying the cross-sectional area throughout. Any variation of width (e.g., cross-section) or thickness could be used, and/or these dimensions could be maintained constant over portions of the coil, according to desired performance characteristics.

Additionally (or alternatively), the spaces between the windings of the coil could be varied to optimize performance of the wireless charging coil 470. For example, the gap width between the traces could be wider towards the outside of the first coil 430 and narrower towards the inside of the first coil 430 (or the opposite). Similarly, the distance

7

between the first coil **430** and second coil **450** in the assembled coil **470** could also be varied to optimize performance. Further, the geometry of the edges of the coil could be varied (e.g., scalloped, castellated, etc.), such as to reduce eddy currents.

FIG. **9** is a cross-sectional view of a portion of the wireless charging coil of FIG. **8**. The first coil **430** comprises sections **414-424** and the second coil **450** comprises sections **402-412**. As shown, the cross-section of the first coil **430** becomes gradually wider and then narrower from a first end to a second end of the first coil **430**. As a result, sections **414** and **424** are the narrowest (e.g., 0.025 in.), followed by sections **404** and **422** (e.g., 0.030 in.), and sections **418** and **420** are the widest (e.g., 0.035 in.). In the same way, the cross-section of the second coil **450** becomes gradually wider and then narrower from a first end to a second end of the second coil **450**. As a result, sections **402** and **412** are the narrowest, and sections **406** and **408** are the widest. Changes in the dimensions of the cross section of the antenna can likewise be varied in other manners.

FIG. **10** is a schematic view of an assembled wireless charging coil **570** with stacked bifilar coils. As discussed above, the wireless charging coil **570** includes a first coil **530** and a second coil **550**. The assembled coil **570** is manufactured and operates in the manner discussed above with respect to FIGS. **1-7**, as well as that discussed in FIGS. **8-9**, except that the first and second coils **530**, **550** are stacked instead of planar. The first coil **530** includes a first end **534** and a second end **536**, and the second coil **550** includes a first end **554** and a second end **556**. Further, varying the skew or offset (e.g., stacking distance) of the first coil **530** relative to the second coil **550** can affect the performance of the wireless charging coil **570**. The first coil **530** and second coil **550** could be connected in series or parallel.

FIG. **11** is a cross-sectional view of a portion of the wireless charging coil of FIG. **10**. This coil **570** is similar to that of FIGS. **8-9**, including a first coil **530** with sections **514-524** and a second coil **550** with sections **502-512**, except that the first and second coils **530**, **550** are stacked instead of planar.

FIGS. **12-13** are views showing an electrical component assembly **690**. More specifically, FIG. **12** is a perspective view of an electrical component assembly **690**. The electrical component assembly **690** comprises a ferrite shield **692**, a pressure sensitive adhesive (PSA) layer **602** positioned on the ferrite shield **692**, an assembled coil **670** (e.g., bifilar coil) positioned therebetween, and jumpers **674**, **676** positioned on the PSA layer **602**.

FIG. **13** is an exploded view of the electrical component assembly **690** of FIG. **12**. The bifilar coil **670** includes a first coil **630** having an inside end **634** and an outside end **636** interconnected with a second coil **650** having an inside end **654** and an outside end **656**. The inside and outside ends are on the same side of the assembled coil **670** for ease of use and assembly (e.g., minimize the distance to electrically connect the ends).

Ferrite shield **692** includes a first hole **696** and a second hole **698** positioned to correlate with the placement of the inside end **634** of the first coil **630** and the inside end **654** of the second coil **650** (e.g., when the coil **670** is placed onto the ferrite shield **692**). Although holes **696**, **698** are shown as circular, any shape and size openings could be used (e.g., one rectangular opening, etc.). These holes **696**, **698** facilitate assembly and welding of the electrical component assembly **690**.

PSA layer **602** and ferrite shield **692** are similarly sized to one another, and although shown as rectangular, both could

8

be of any shape (e.g., circular). PSA layer secures the relative placement of the assembled coil **670** to the ferrite shield **692**. PSA layer **602** could have adhesive on one or both sides, and could include a polyethylene terephthalate (PET) film area **604** free of adhesive on one or both sides. PET film area **604** facilitates assembly and welding of the electrical component assembly **690**.

PSA layer **602** includes a first hole **606** and a second hole **608** in the PET film area **604** which correlate in position with the placement of the inside end **634** of the first coil **630** and the inside end **654** of the second coil **650** (as well as the first hole **696** and second hole **698** of the ferrite substrate **692**). Although holes **606**, **608** are shown as circular, any shape and size openings could be used (e.g., one rectangular opening). Holes **606**, **608** provide access through the PSA layer **602** to electrically connect jumpers **674**, **676** with the inside ends **634**, **654** of the assembled coil **670**. The PET film area **604** facilitates attachment of the jumpers **674**, **676** to the assembly **690**.

FIG. **14** is a perspective view of a resonant coil **730**. Resonant coil **730** could be a generally rectangular planar spiral trace **731**, although the trace **731** could form any suitable shape. The resonant coil **730** includes an inside end **734** and an outside end **736**. The trace **731** is stamped on a strip or sheet of metal (e.g., copper, aluminum, etc.). The dimensions of the coil **730** could vary depending on the application of the coil **730**. The coil **730** could be of any suitable thickness, and of any suitable overall dimensions. The trace **731** could also be of any suitable dimensions. The dimensions could vary depending on physical and performance requirements. The coil **730** could be made of any suitable material for wireless power transfer, such as, for example, copper, copper alloy, aluminum, aluminum alloy, tempered copper alloy (e.g., C110), etc. The gaps between the windings of the trace **731** are larger for a resonant coil than for other types of inductive coils due to performance requirements.

Stamping provides a scalable process for high volume production with high yields. The stamped trace **731** is not prone to unwinding and can allow for a thicker trace. This is advantageous compared with other existing technologies. For example, winding wire (e.g., copper) to a specific pattern on a surface is difficult and the wound wire can unwind. Further, etched copper is expensive and could be limited to a maximum thickness (e.g., 0.004 in. thick).

The trace **731** of the resonant coil **730** includes a first side **737** and a second side **739** offset from the first side **737** by angled portions **741** of the trace **731**. The angled portions **741** are aligned with one another (e.g., occur along line B-B), and angled in the same direction. In other words, angled portions **741** are all angled toward a particular side of the coil **730** (e.g., towards one side of line A-A), such that a first portion **737** (e.g., upper portion) of the coil **730** is shifted relative to a second portion **739** (e.g., lower portion) of the coil **730**.

FIG. **15** is a perspective view of a resonant coil assembly **790**, including the first resonant coil **730** from FIG. **14**. The resonant coil assembly **790** includes a first coil **730** and a second coil **750**, which are identical to one another (which minimizes manufacturing costs). The resonant coil assembly **790** could be laminated such that the first coil **730** and second coil **750** are laminated to a film **702** (e.g., PET film), such as by an adhesive (e.g., heat activated, pressure sensitive, etc.) to provide more stability in downstream operations. The first coil **730** could be adhered to one side of the film **702** and the second coil **750** could be adhered to the opposite side of the film **702**.

The first coil **730** includes an outside end **736** and an inside end **734**, and the second coil **750** includes an outside end **756** and an inside end **754**. The first coil **730** and second coil **750** could be exactly the same size and shape coil, except that the second coil **750** is rotated 180 degrees about line D-D. In this way, the trace **731** of the first coil **730** is positioned between the gap formed by the windings of the trace **751** of the second coil **750** (and vice-versa), except at the angled portions of each coil along line D-D, where the traces cross one another. The inside end **734** of the first coil **730** could be adjacent to (and in electrical connection with) the inside end **754** of the second coil **750**, and the outside end **736** of the first coil **730** could be adjacent to the outside end **756** of the second coil **750**.

FIGS. **16-18** are views of a stamped resonant coil **870**. FIG. **16** is a perspective view of a folded stamped resonant coil **870**. The coil **870** comprises connector sheet **871**, a first set of traces **831** of a first coil portion **830** with ends thereof connected to an edge of the connector sheet **871** at connection points **873**, and a second set of traces **851** of a second coil portion **850** with ends thereof connected to the same edge of the connector sheet **871** at connection points **873**. To create the stamped resonant coil **870**, a (single) sheet of metal is stamped to form the first set of traces **831** and the second set of traces **851** (e.g., such that the arcs of each trace of the first and second sets of traces **831**, **851** are oriented in the same direction). The ends of the first and second set of traces **831**, **851** are then connected to the same edge of connector sheet **871** (e.g., insulation material). The connector sheet **871** facilitates wiring of the sets of traces **831**, **851** to each other, as well as facilitates the connection of the stamped resonant coil **870** to electronic circuitry. The ends of the first and second set of traces **831**, **851** are then wired to each other, such as by using a series of jumpers and/or traces. For example, the jumpers and/or traces could be in the connector sheet **871** and could run parallel to the connector sheet (and perpendicular to the first and second sets of traces **831**, **851**).

FIG. **17** is a perspective view of the coil **870** of FIG. **16** partially opened. As shown, the first set of traces **831** of the first coil portion **830** are bent at connection points **873**. FIG. **18** is a perspective view of the coil **870** of FIG. **16** fully opened. As shown, the first set of traces **831** of the first coil portion **830** continue to be bent at connection points **873** until the first coil portion **830** is planar with the second coil portion **850**. Bending of the traces could result in fracturing on the outside surface thereof, in which case, ultrasonic welding could be used to ensure electrical conductivity. Alternatively, the first and second sets of traces **831**, **851** could connect to opposing edges of the connector sheet **871**, such that bending could not be required. Stamping (and bending) in this way reduces the amount of scrap generated, thereby increasing material utilization.

FIG. **19** is an exploded view of a low profile electrical component assembly **990**. More specifically, the low profile electrical component assembly **990** comprises a substrate **992** (e.g., PET layer), a filler material layer **933** (e.g., rubber, foam, durometer, etc.), a coil **930** (e.g., resonant coil), and a protective layer **902**. The protective layer **902** could be partly translucent and could comprise a tab (e.g., for applying or removing).

FIG. **20** is a perspective view of the filler material **933** of FIG. **19**. Filler material **933** comprises grooves **935** which correspond in size and shape to that of the coil **930**. In this way, the coil **930** is nested in filler material **933**, which

protects the coil shape from bending and/or deformation. Such an assembly facilitates handling of the coil **930** for subsequent operations.

FIG. **21** is a diagram showing processing steps **1000** for manufacturing a wireless charging coil with adhesive (e.g., glue). In step **1002**, a metal sheet is stamped to form a first coil with tie bars. In step **1004**, a metal sheet is stamped to form a second coil with tie bars. In step **1006**, a first coil is applied to a first laminate (e.g., plastic substrate, Transil-wrap) with an adhesive layer to adhere thereto. In step **1008**, a second coil is applied to a second laminate (e.g., plastic substrate, Transilwrap) with an adhesive layer to adhere thereto. In step **1010**, the first coil is stamped to remove tie bars. In step **1012**, the second coil is stamped to remove tie bars. Accordingly, the first coil and second coil are fixed in place as a result of the adhesive layer on the plastic laminate. In step **1014** the first coil with the laminate adhered thereto, is assembled with the second coil with the laminate adhered thereto. More specifically, as discussed above, the first coil with a spiral trace fits into the space formed between a trace of a second coil, and conversely, the second coil fits into the space formed between the trace of the first coil, thereby forming an assembled coil. As a result, the assembled coil is positioned between (e.g., sandwiched between) the first laminate and the second laminate.

In step **1016**, a heat press is applied to the assembled coil to displace and set the adhesive layer from the first and second laminates. More specifically, the heat applied should be hot enough to melt the adhesive (e.g., more than 220-250° F.), but not hot enough to melt the plastic laminate. The pressure applied pushes the first coil towards the second laminate, such that the adhesive of the second laminate positioned in between the trace of the second coil is displaced and forced between the spaces between the first trace of the first coil and the second trace of the second coil. Squeezing the first and second coils together (e.g., with heat and/or pressure) migrates the adhesive to the spaces in between the traces (e.g., to insulate them from one another). This covers or coats the traces of the first coil and the second coil, and bonds the first coil to the second coil. The pressure, heat, and duration could vary depending on the desired cycle time for manufacturing the assembled coil. It is noted that such a process could result in a planar offset of the first coil from the second coil when assembled together.

FIG. **22** is a partial cross-sectional view of a first stamped coil **1130** when applied to a first laminate **1123**. The first laminate **1123** includes an adhesive layer **1127** applied to a surface thereof. When the first stamped coil **1130** is applied to the first laminate **1123**, some of the adhesive **1127** is displaced to the sides, such that the displaced adhesive **1127** accumulates against the sides of the trace **1131** of the first stamped coil **1130**. Accordingly, the adhesive **1127** on the sides and underneath the trace **1131** of the first stamped coil **1130** prevents the trace **1131** from moving relative to the first laminate **1123**.

FIG. **23** is a partial cross-sectional view of an assembled coil positioned between a first laminate **1123** and second laminate **1125**. As described above, when assembled, the first coil **1130** with a first trace **1131** fits into the space formed between a second trace **1151** of a second coil **1150**, and conversely, the second coil **1150** fits into the space formed between the first trace **1131** of the first coil **1130**, thereby forming an assembled coil **1170**. As a result, the assembled coil **1170** is positioned between (e.g., sandwiched between) the first laminate **1123** and the second laminate **1125**. This displaces the first adhesive **1127** between the first

11

trace **1131** of the first coil **1130**, and displaces the second adhesive **1129** between the second trace **1151** of the second coil **1150**.

When the first and second adhesive layers **1127**, **1129** are set (e.g., by pressure and/or heat), the adhesive covers the surface of the traces **1131**, **1151** (e.g., by melting), and acts as an insulator and stabilizer for the traces **1131**, **1151**. In other words, the first and second coils **1130**, **1150** are bonded together. This prevents relative movement of the traces **1131**, **1151**, which prevents the first stamped coil **1130** from contacting the second stamped coil **1150** and shorting out the assembled coil **1170**. As an example, the first and second stamped coils **1130**, **1150** could each be 0.0125 in. thick, and each adhesive layer **1127**, **1129** could be 0.0055 in. thick, for a total thickness of 0.0225 in. After pressure and/or heat have been applied, the total thickness could be 0.0205 in., with a total adhesive displacement of 0.002 in.

FIGS. **24-25** are partial views of an assembled coil **1170**. More specifically, FIG. **24** is partial cross-sectional view of an assembled coil **1170**, and FIG. **25** is a partial top view of the assembled coil **1170** of FIG. **24**. The assembled coil **1170** comprises (as discussed above) a first coil **1130** with a spiral trace **1131**, which fits into the space formed between a trace **1151** of a second coil **1150**, and conversely, the second coil **1150** fits into the space formed between the trace **1131** of the first coil **1130**. Accordingly, the first and second coils **1130**, **1150** form a parallel planar spiral.

As discussed above, a first laminate **1123** (e.g., Transilwrap) with a first adhesive layer is applied to the first stamped coil **1130**, and a second laminate **1125** (e.g., Transilwrap) with a second adhesive layer applied to the second stamped coil **1150**. As a result, the first and second stamped coils **1130**, **1150** are positioned between the first and second laminates **1123**, **1125**. When the first and second coils **1130**, **1150** are assembled with one another, the adhesive **1127** (dyed black for clarity) is displaced to fill the spaces between the first and second traces **1131**, **1151**.

FIG. **25** shows the displacement of adhesive **1127** when the first coil **1130** and second coil **1150** are assembled. More specifically, the adhesive **1127** (dyed black for clarity) is shown between the first trace **1131** and the second trace **1151**. Further, in the particular example shown, more pressure has been exerted on the left side first and second traces **1131a**, **1151a**, than the right side traces **1131b**, **1151b**. As a result, less adhesive **1127** has been displaced on the right side than the left side, thereby making the right side trace **1151b** less visible than the left side trace **1151a** (as a result of the black dyed adhesive **1127**).

FIG. **26** is a top view of an assembled coil **1270** of the present disclosure. As discussed above, the assembled coil **1270** comprises a first coil **1230** with a first spiral trace **1231** having an inside end **1234** and an outside end **1236**, a second coil **1250** with a second spiral trace **1251** having an inside end **1254** and an outside end **1256**, a first jumper **1277** attached to the outside end **1236** of the first coil **1230**, a second jumper **1274** attached to the inside end **1234** of the first coil **1230** and the outside end **1256** of the second coil **1250**, and a third jumper **1276** attached to the inside end **1254** of the second coil **1250**. The first and second spiral coils **1230**, **1250** forming an inside portion **1272**.

A laminate **1227** (e.g., film, adhesive film, plastic film, etc.) covers the assembled coil **1270** including the inside portion **1272**. As explained above, the adhesive layer of the laminate **1227** stabilizes the first coil **1230** and second coil **1250** and insulates them. This prevents relative movement of the first and second coil **1230**, **1250** and prevents the first and

12

second coils **1230**, **1250** from accidentally contacting one another and shorting out the assembled coil **1270**

The laminate **1227** could define one or more cutouts. More specifically, the laminate **1227** could define an inside cutout **1223** to provide access to (e.g., expose) the first inside end **1234** of the first coil **1230** and the second inside end **1254** of the second coil **1250**. The laminate **1227** could also define an outside cutout **1225** to provide access to (e.g., expose) the first outside end **1236** of the first coil **1230** and the second outside end **1256** of the second coil **1250**. The first cutout **1223** could extend to substantially of the inside portion **1272**. The assembled coil **1270** (and the first and second coils **1230**, **1250** thereof) could be of any material and/or style (e.g., A6 style coil).

For any of the embodiments discussed above, the wireless charging coil (e.g., bifilar coil) could be constructed and then (e.g., at a different location and/or time) the first and second coils of the wireless charging coil, whether stacked or planar, could be electrically connected to each other in series or parallel depending on electrical requirements.

Having thus described the system and method in detail, it is to be understood that the foregoing description is not intended to limit the spirit or scope thereof. It will be understood that the embodiments of the present disclosure described herein are merely exemplary and that a person skilled in the art may make any variations and modification without departing from the spirit and scope of the disclosure. All such variations and modifications, including those discussed above, are intended to be included within the scope of the disclosure.

What is claimed is:

1. A wireless charging coil comprising:
 - a first stamped coil having a first spiral trace, the first spiral trace defining a first space between windings;
 - a second stamped coil having a second spiral trace, the second spiral trace defining a second space between windings,
 - the first stamped coil and second stamped coil in coplanar relation, the first stamped coil positioned within the second space of the second stamped coil, and the second stamped coil positioned within the first space of the first stamped coil, the first and second coils electronically connected;
 - a first laminate attached to the first stamped coil and fixing the first stamped coil in place; and
 - a second laminate attached to the second stamped coil and fixing the second stamped coil in place,
 the first laminate being engaged with the second laminate to bond the coils together and to insulate the coils.
2. The wireless charging coil of claim 1, wherein the first stamped coil and the second stamped coil are positioned between the first laminate and the second laminate.
3. The wireless charging coil of claim 1, wherein the first stamped coil and second stamped coil are connected in series.
4. The wireless charging coil of claim 1, wherein the first stamped coil and second stamped coil are connected in parallel.
5. The wireless charging coil of claim 1, wherein the first stamped coil includes an inside end and an outside end, the inside end disposed on the same side of the first stamped coil as the outside end.
6. The wireless charging coil of claim 5, further comprising a first jumper attached to the outside end of the first coil.
7. The wireless charging coil of claim 6, wherein the second stamped coil includes an inside end and an outside

end, and further comprising a second jumper attached to the inside end of the first coil and the outside end of the second coil.

8. The wireless charging coil of claim 7, further comprising a third jumper attached to the inside end of the second coil.

* * * * *