



(12) **United States Patent**
Niakan et al.

(10) **Patent No.:** **US 9,816,468 B2**
(45) **Date of Patent:** **Nov. 14, 2017**

(54) **AIR FILTER RETENTION INTERFACE**

(56) **References Cited**

(71) Applicants: **Shahriar Nick Niakan**, Anaheim Hills, CA (US); **Saul Daniel Zambrano**, Corona, CA (US); **Stuart T. Miyagishima**, Corona, CA (US)

(72) Inventors: **Shahriar Nick Niakan**, Anaheim Hills, CA (US); **Saul Daniel Zambrano**, Corona, CA (US); **Stuart T. Miyagishima**, Corona, CA (US)

(73) Assignee: **Advanced Flow Engineering**, Corona, CA (US)

(*) Notice: Subject to any disclaimer, the term of this patent is extended or adjusted under 35 U.S.C. 154(b) by 58 days.

(21) Appl. No.: **13/986,263**

(22) Filed: **Apr. 16, 2013**

(65) **Prior Publication Data**
US 2014/0305089 A1 Oct. 16, 2014

(51) **Int. Cl.**
B01D 39/00 (2006.01)
B01D 46/00 (2006.01)
F02M 35/024 (2006.01)

(52) **U.S. Cl.**
CPC **F02M 35/02416** (2013.01)

(58) **Field of Classification Search**
CPC B01D 46/10; B01D 46/0002; B01D 46/0005; B01D 46/001; B01D 46/0004
USPC 55/495
See application file for complete search history.

U.S. PATENT DOCUMENTS

4,065,276	A *	12/1977	Nakaya et al.	96/380
4,244,718	A *	1/1981	Noddin	55/377
4,541,658	A *	9/1985	Bartholomew	285/319
4,902,043	A *	2/1990	Zillig et al.	285/4
5,195,787	A *	3/1993	Bartholomew	285/319
5,752,726	A *	5/1998	Fixemer	285/39
5,868,808	A *	2/1999	Henderson	55/336
5,888,260	A *	3/1999	Sica	55/331
5,954,345	A *	9/1999	Svoboda et al.	277/626
5,971,445	A *	10/1999	Norkey	285/319
6,029,981	A *	2/2000	Hawley et al.	277/607
6,383,244	B1 *	5/2002	Wake et al.	55/482
6,739,597	B2 *	5/2004	Nicolia et al.	277/609
6,817,631	B1 *	11/2004	Gavin	285/139.1
6,866,304	B2 *	3/2005	Kaminski et al.	285/319
7,299,688	B2 *	11/2007	Salvisberg	73/114.14
7,306,235	B2 *	12/2007	Roberts et al.	277/593
7,497,478	B2 *	3/2009	Callahan	285/305

(Continued)

Primary Examiner — Amber R Orlando

(74) Attorney, Agent, or Firm — Gibbs & White P.C.; Franklin E. Gibbs

(57) **ABSTRACT**

An air filter retention interface for use with an internal combustion engine is disclosed. The interface is substantially secured in an opening of a wall and the interface attaches to an air filter at the front end of the interface and an air intake tube on the back end of the interface. The interface has a filter sleeve and a filter base. During operation of the engine the filter sleeve is disposed through the opening in the wall such that the wall is between beads disposed on the external surface of the filter sleeve and the filter base thereby substantially securing the interface in place and the front end of the filter base is attached to the filter and the back end of the filter base is attached to the air intake tube and air passes through the filter then through the filter base and filter sleeve and then into the air intake tube and toward the engine.

2 Claims, 3 Drawing Sheets

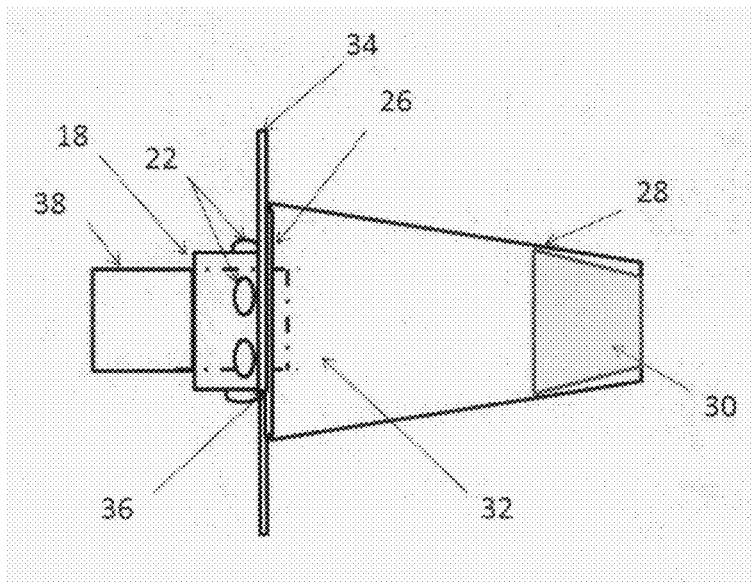

(56)

References Cited

U.S. PATENT DOCUMENTS

7,878,299	B2 *	2/2011	Geyer, III	181/243
8,101,003	B2 *	1/2012	Krisko et al.	55/502
2009/0107340	A1 *	4/2009	Niakan et al.	96/135
2009/0165447	A1 *	7/2009	Hiranuma et al.	60/295
2010/0224161	A1 *	9/2010	Kolczyk et al.	123/196 A
2012/0304400	A1 *	12/2012	Jenkins et al.	8/137

* cited by examiner

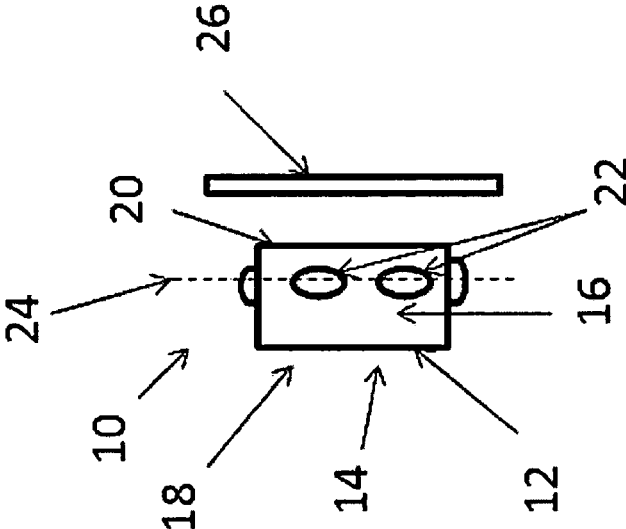

Fig. 1

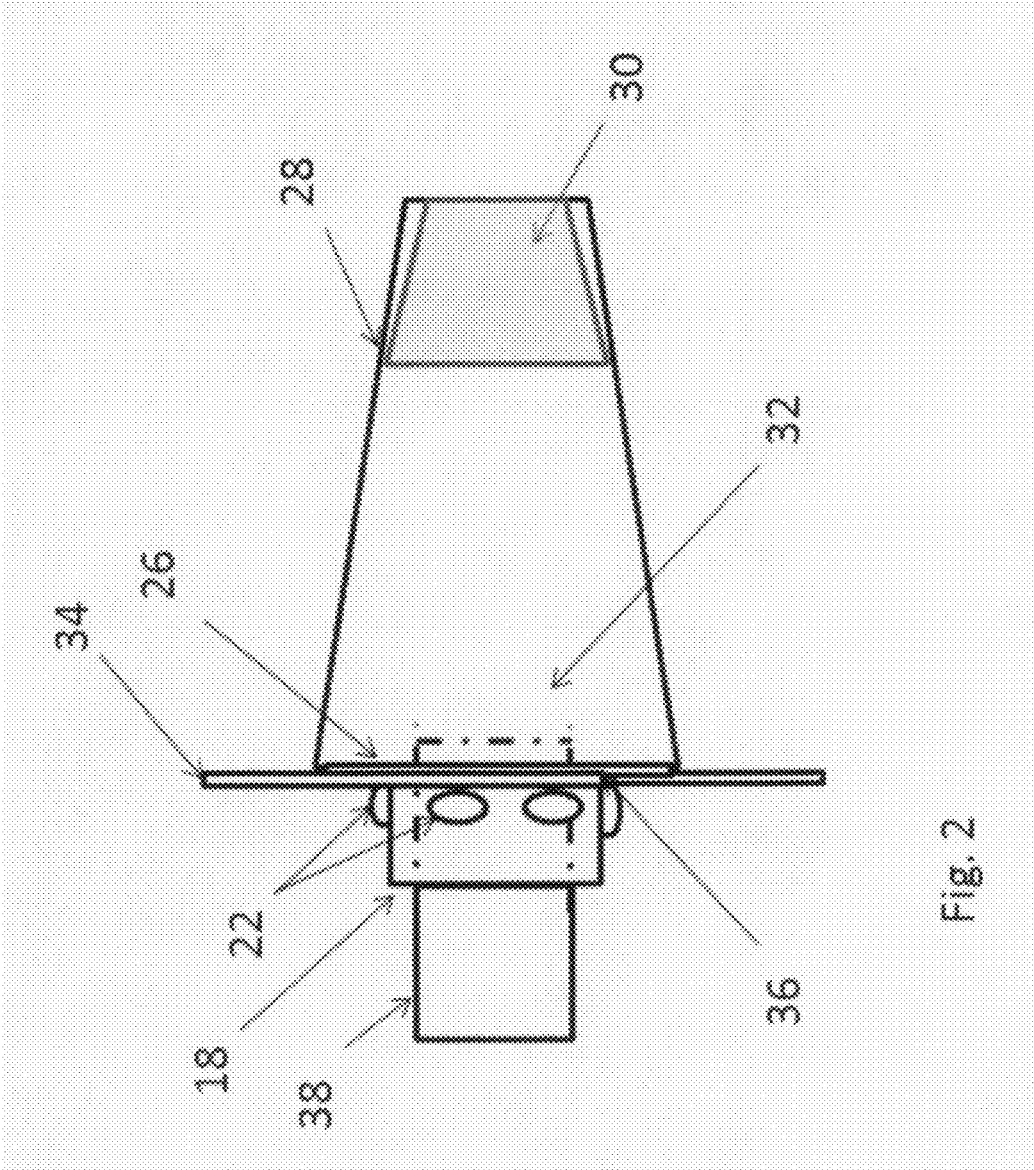

Fig. 2

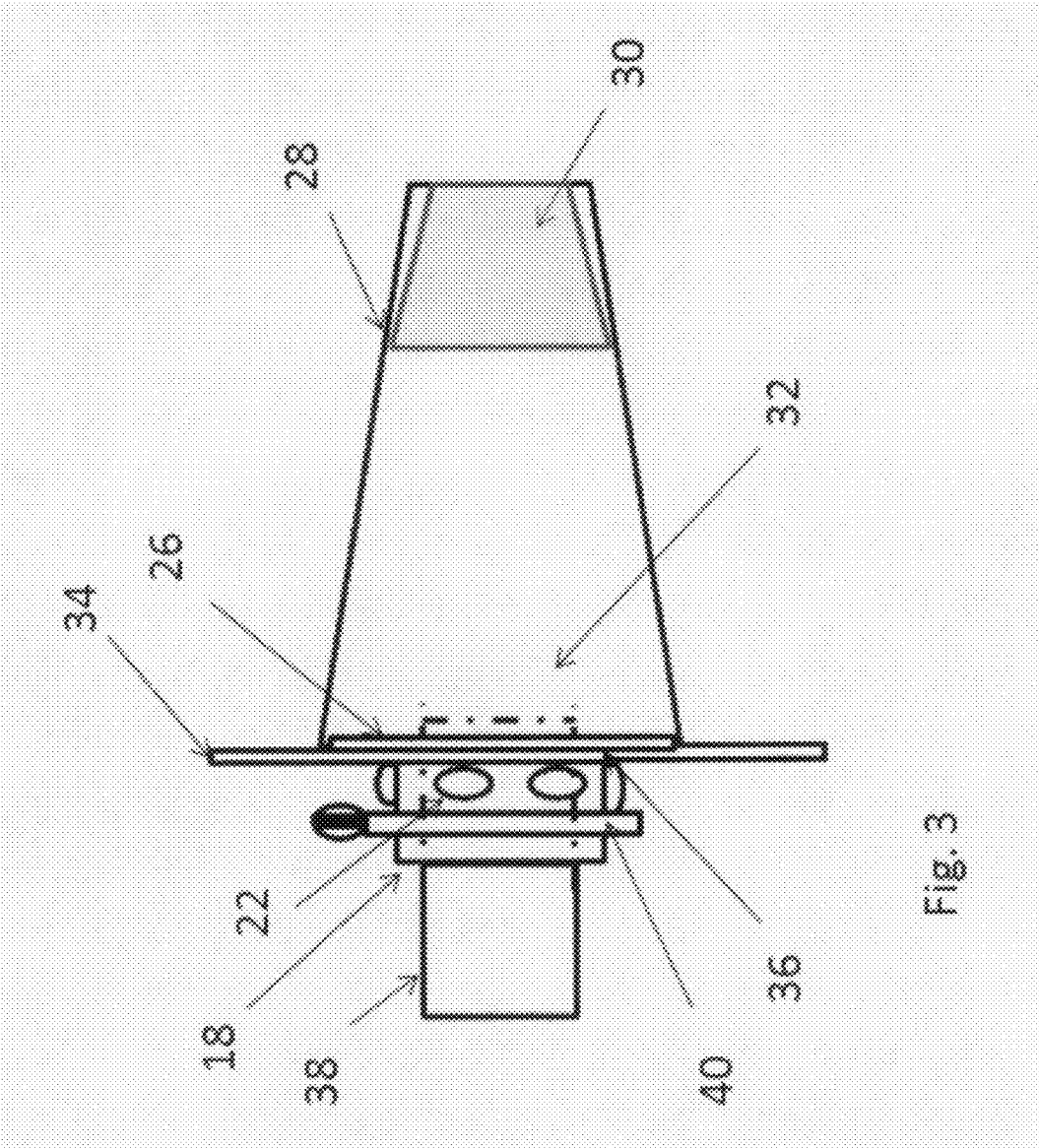

Fig. 3

1

AIR FILTER RETENTION INTERFACE

FIELD OF THE INVENTION

This invention generally relates to air filters for use with internal combustion engines.

BACKGROUND OF THE INVENTION

Air filters are critical components for internal combustion engines. The filter performs the function of removing debris from the air as the air is transferred into the engine. This reduces contamination that would otherwise enter the engine. In turn, the cleaner air allows the engine to run more efficiently and reduces wear that can occur with the introduction of particulate matter in the combustion process.

There are a variety of techniques used to secure the filter in proximity to the engine. However, the existing techniques tend to be difficult to use when installing or replacing the filter. What is needed is a more efficient technique for installing or replacing the filter.

SUMMARY OF THE INVENTION

In accordance with the present disclosure, an air filter retention interface for use with an internal combustion engine is provided. In one embodiment, the interface is substantially secured in an opening of a wall and the interface attaches to an air filter at the front end of the interface and an air intake tube on the back end of the interface.

The interface has a filter sleeve having an internal surface, an external surface, an outer radius, and a front and back ends.

The external surface of the filter sleeve has beads extending above the external surface and disposed substantially along a circumferential line extending around the external surface.

There is an filter base having an outer radius greater than the outer radius of the filter sleeve and the filter base having an opening and the filter base is attached to the front end of the filter sleeve;

During operation of the engine the filter sleeve is disposed through the opening in the wall such that the wall is between the beads and the filter base and the interface is substantially secured in place and the filter base is attached to the filter and the back end of the filter sleeve is attached to the air intake tube and air passes through the filter then through the filter sleeve and then into the air intake tube and toward the engine.

BRIEF DESCRIPTION OF THE DRAWINGS

The invention is generally shown by way of reference to the accompanying drawings in which:

FIG. 1 is a side view of the elements of one embodiment of an air filter retention interface;

FIG. 2 is a side view of one embodiment of the air filter retention interface, filter, wall, and air inlet tube; and

FIG. 3 is a side view of one embodiment of the air filter retention interface, filter, wall, air inlet tube, and clamp.

DETAILED DESCRIPTION OF THE INVENTION

FIG. 1 shows an embodiment of the air filter retention interface 10. There is a filter sleeve 12 having an internal

2

surface 14 and an external surface 16. The filter sleeve also has a back end 18 and a front end 20. The filter sleeve is basically a tube that can be fitted over another tube to some degree such as an engine air intake tube. In one embodiment, the filter sleeve is somewhat flexible. Other embodiments can include a more rigid structure. On the external surface 16 there are beads 22 that roughly are along a line 24 and the beads are thus substantially along a circumferential line around the external surface of the filter sleeve. There is also a filter base 26.

Turning to FIG. 2, the filter base 26 attaches to the front end of the sleeve. The base 26 also attaches to the filter 28. The filter base 26 has a passage that allows air to flow between the filter 28 and the filter sleeve 12. The filter 28 has input ports 30 where air enters and is filtered. There is also an output port 32 inside the filter where the filtered air can be directed away from the filter 28.

In one embodiment, the beads 22 are made of a relatively flexible material such as rubber. In use, the filter sleeve 12 is attached to the base 26. The sleeve is placed through an opening 36 in the wall 34. The wall 34 may be a part of a filter housing chamber or another structure possibly within an engine compartment that can provide support for the interface. The opening 36 is large enough to allow the filter sleeve 12 to pass and would normally not allow the beads 22 to pass if the beads 22 and base 26 were rigid. Since the beads 22 are somewhat flexible, the beads 22 and filter sleeve 12 structure can pass through the opening 36. The wall then abuts the filter base 26 on one side and the beads 22 on the other. This relatively secures the interface 10 in place. It should be appreciated that the geometry and number of the beads 22 can be chosen to fit any particular application desired and is not limited to those in the figures. In another embodiment, the filter sleeve 12 can also be somewhat flexible. The number and geometry of the beads 22 can vary.

FIG. 2 also identifies an air inlet tube 38. The air inlet tube 38 passes through the back end 18 of the filter sleeve 12. The tube 38 can extend through the sleeve 12 and filter base 26 into the filter 28. However, the depth of penetration of the tube 38 can be a function of any particular application. Also, while it may appear that the attachment end of the filter may be generally circular in shape, filters of other attachment end geometries and structural geometries are used in other embodiments.

Turning to FIG. 3, a clamp 40 as well known in the art is identified. The clamp 40 extends circumferentially around the filter sleeve 12. The air intake tube 38 extends far enough into the sleeve 12 so that the clamp 40 can force the filter sleeve 12 against the tube 38 thereby substantially securing the tube 38 in place. The clamp 40 forces the internal surface 14 of the filter sleeve 12 against the tube 38.

As FIG. 3 also indicates, the filter sleeve 12, filter base 26 and filter 28 can be combined to form a single structure. The sleeve 12 and beads 22 can still be passed through the opening 36 in the wall 34. In other embodiments, the filter base 26 could be detachably connected to a filter by a number of conventional methods including a threading structure. It should also be appreciated that the base 26 could be of a number of geometries to fit the geometries of a desired filter or that an interface could be used to couple a filter base 26 of one geometry to a filter 28 of another geometry.

While embodiments have been described in detail, it should be appreciated that various modifications and/or variations may be made without departing from the scope or spirit of the invention. In this regard it is important to note that practicing the invention is not limited to the applications

3

described herein. Many other applications and/or alterations may be utilized provided that such other applications and/or alterations do not depart from the intended purpose of the invention. Also, features illustrated or described as part of one embodiment may be used in another embodiment to provide yet another embodiment such that the features are not limited to the embodiments described herein. Thus, it is intended that the invention cover all such embodiments and variations. Nothing in this disclosure is intended to limit the scope of the invention in any way.

What is claimed is:

1. An air filter unit for use with an internal combustion engine having a filtering housing chamber having a wall and opening in the wall for receiving the air filter unit, the air filter unit comprising:

a filter sleeve having an external surface, and a front and back ends;

the external surface of the filter sleeve having beads disposed substantially along a circumferential line

4

extending around the external surface and the beads adapted to abut the filter housing chamber wall;

a filter base disposed on the front end of the filter sleeve and the filter base adapted to abut the wall when the filter sleeve is disposed through the opening in the wall such that the wall is between the beads and the filter base;

the beads adapted to abut the wall when the filter sleeve is disposed through the opening in the filter housing chamber wall such a that the wall is between the beads and the filter base;

an air filter attached to the filter base; and the filter, filter base, and filter sleeve forming a single unit.

2. The air unit of claim 1, further comprising a clamp disposed about the external surface of the filter sleeve, wherein the clamp surrounds a portion of the filter sleeve that covers a portion of the air intake tube and the clamp secures the air intake tube to the filter sleeve.

* * * * *