

- [54] **EXPANDABLE INTRALUMINAL GRAFT, AND METHOD AND APPARATUS FOR IMPLANTING AN EXPANDABLE INTRALUMINAL GRAFT**
- [75] **Inventor:** Julio C. Palmaz, San Antonio, Tex.
- [73] **Assignee:** Expandable Grafts Partnership, San Antonio, Tex.
- [21] **Appl. No.:** 796,009
- [22] **Filed:** Nov. 7, 1985
- [51] **Int. Cl.<sup>4</sup>** ..... A61M 29/00
- [52] **U.S. Cl.** ..... 128/343; 604/104; 604/96; 623/1
- [58] **Field of Search** ..... 128/343-344, 128/1 R; 623/1; 604/96, 104, 106-109

- 4,580,568 4/1986 Gianturco .
- 4,650,466 3/1987 Luther ..... 604/266

**FOREIGN PATENT DOCUMENTS**

- 0183372 4/1986 European Pat. Off. .
- 2135585 9/1984 United Kingdom .

**OTHER PUBLICATIONS**

- "Flexible Balloon-Expanded Stent for Small Vessels", *Radiology*, Jan. 1987, pp. 276-280, vol. 162, No. 1.
- "Expandable Intraluminal Graft: A Preliminary Study"; *Radiology* Jul. 1985; paper presented at 70th Scientific Assembly and Annual Meeting of the Radiological Society of North America, Nov. 25, 1984, by Julio C. Palmaz et al.
- "Percutaneous Endovascular Stents: An Experimental Evaluation"; Wright et al., *Radiology* 156; 1985.
- "Transluminal Expandable Nitinol Coil Stent Grafting: Preliminary Report" Dotter et al.; *Radiology* 147; 1983.
- "Non Surgical Placement of Arterial Endoprostheses: A New Technique Using Nitinol Wire"; Cragg et al.; *Radiology* 147, 1983.
- "Transluminally-Placed Coilspring Endurtorial Tube Grafts"; Dotter *Investigative Radiology*; Sep.-Oct. 1969.
- "Radio Logical Follow-Up of Transluminally Inserted Vascular Endoprostheses: An Experimental Study Using Expanding Spirals"; *Radiology* 152; 1984.

[56] **References Cited**

**U.S. PATENT DOCUMENTS**

2,701,559	2/1955	Cooper	128/344
3,774,596	11/1973	Cook	
3,868,956	3/1975	Alfidi et al.	
3,882,845	5/1975	Bucalo	128/1 R
3,889,685	6/1975	Miller et al.	128/348
4,018,230	4/1977	Ochiai et al.	128/344
4,140,126	2/1979	Choudhury	
4,141,364	2/1979	Schultze	
4,183,102	1/1980	Guiset	3/1.4
4,299,226	11/1981	Banka	
4,318,410	3/1982	Chin	
4,416,028	11/1983	Erikson et al.	
4,425,908	1/1984	Simon	
4,483,339	11/1984	Gillis	
4,483,340	11/1984	Fogarty et al.	128/344
4,503,569	3/1985	Dotter	3/1.4
4,512,338	4/1985	Balko	
4,553,545	11/1985	Maass	
4,560,374	12/1985	Hammerslag	
4,562,596	1/1986	Kornberg	
4,564,014	1/1986	Fogerty et al.	
4,577,631	3/1986	Kreamer	

*Primary Examiner*—C. Fred Rosenbaum  
*Assistant Examiner*—Gene B. Kartchner  
*Attorney, Agent, or Firm*—Ben D. Tobor

[57] **ABSTRACT**

An expandable intraluminal vascular graft is expanded within a blood vessel by an angioplasty balloon associated with a catheter to dilate and expand the lumen of a blood vessel. The graft may be a wire mesh tube.

**28 Claims, 6 Drawing Figures**

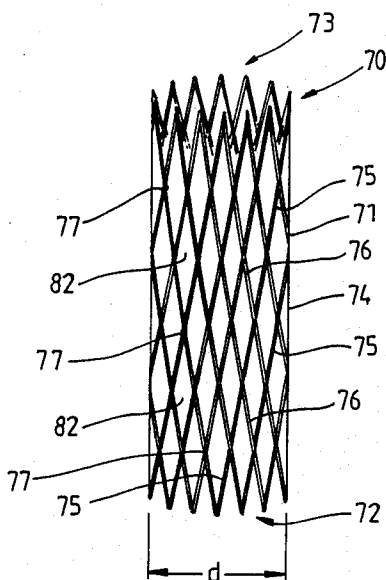

**Fig. 1A**

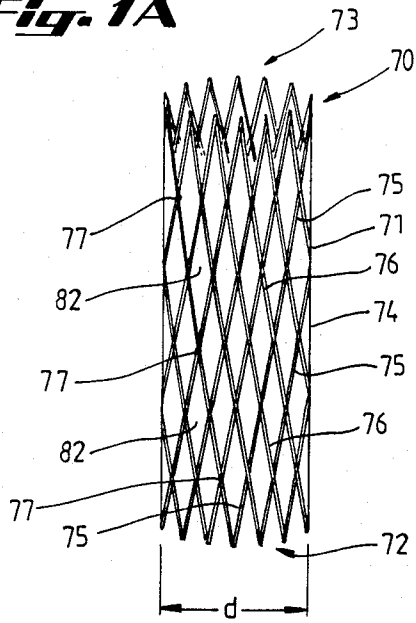

**Fig. 1B**

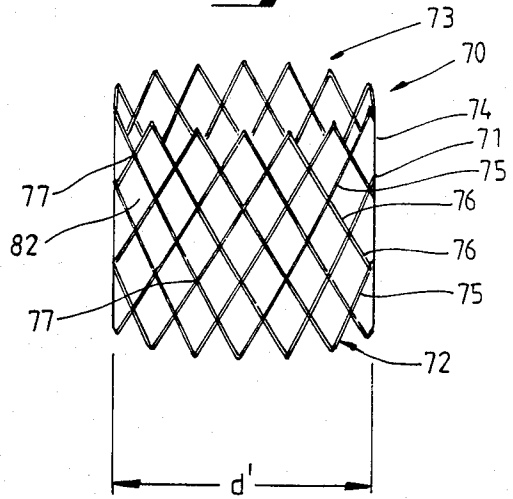

**Fig. 2A**

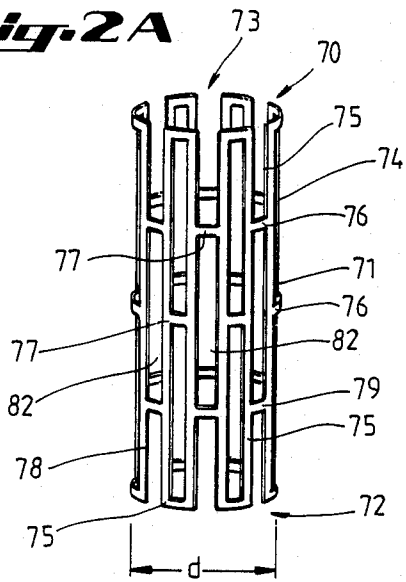

**Fig. 2B**

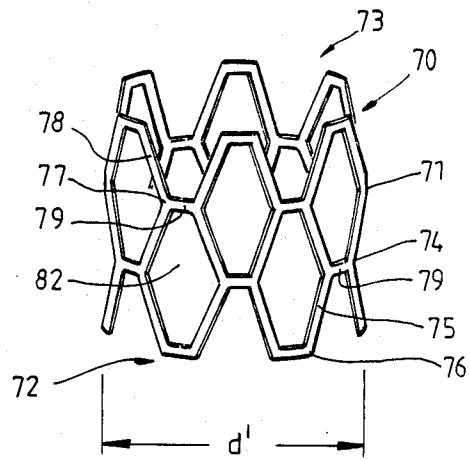

**Fig. 3**

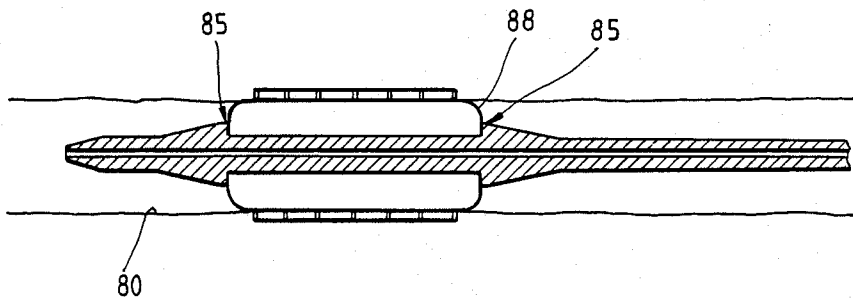
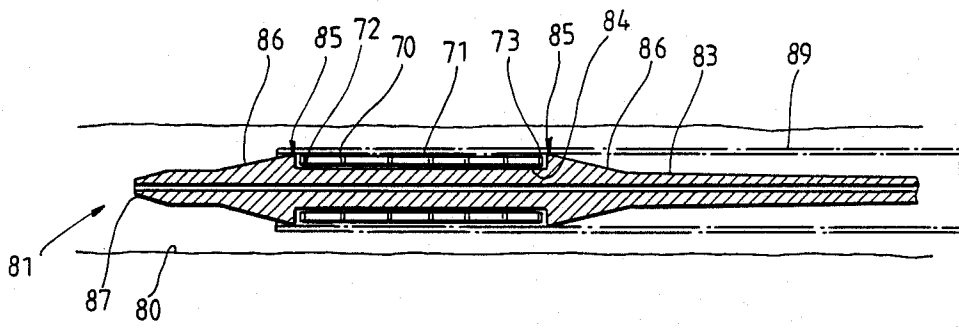

**Fig. 4**

## EXPANDABLE INTRALUMINAL GRAFT, AND METHOD AND APPARATUS FOR IMPLANTING AN EXPANDABLE INTRALUMINAL GRAFT

### Field of the Invention

The government of the United States of America retains a non-exclusive, irrevocable, royalty-free license in this invention for all governmental purposes, pursuant to 37 C.F.R. §100.6(b) (2).

The invention relates to an expandable intraluminal graft for use within a body passageway or duct and, more particularly, expandable intraluminal vascular grafts which are particularly useful for repairing blood vessels narrowed or occluded by disease; and a method and apparatus for implanting expandable intraluminal grafts.

### Description of the Prior Art

Intraluminal endovascular grafting has been demonstrated by experimentation to present a possible alternative to conventional vascular surgery. Intraluminal endovascular grafting involves the percutaneous insertion into a blood vessel of a tubular prosthetic graft and its delivery via a catheter to the desired location within the vascular system. Advantages of this method over conventional vascular surgery include obviating the need for surgically exposing, incising, removing, replacing, or bypassing the defective blood vessel.

Structures which have previously been used as intraluminal vascular grafts have included coiled stainless steel springs; helically wound coil springs manufactured from an expandable heat-sensitive material; and expanding stainless steel stents formed of stainless steel wire in a zig-zag pattern. In general, the foregoing structures have one major disadvantage in common. Insofar as these structures must be delivered to the desired location within a given body passageway in a collapsed state, in order to pass through the body passageway, there is no effective control over the final, expanded configuration of each structure. For example, the expansion of a particular coiled spring-type graft is predetermined by the spring constant and modulus of elasticity of the particular material utilized to manufacture the coiled spring structure. These same factors predetermine the amount of expansion of collapsed stents formed of stainless steel wire in a zig-zag pattern. In the case of intraluminal grafts, or prostheses, formed of a heat sensitive material which expands upon heating, the amount of expansion is likewise predetermined by the heat expansion characteristics of the particular alloy utilized in the manufacture of the intraluminal graft.

Thus, once the foregoing types of intraluminal grafts are expanded at the desired location within a body passageway, such as within an artery or vein, the expanded size of the graft cannot be changed. If the diameter of the desired body passageway has been miscalculated, an undersized graft might not expand enough to contact the interior surface of the body passageway, so as to be secured thereto. It may then migrate away from the desired location within the body passageway. Likewise, an oversized graft might expand to such an extent that the spring force, or expansion force, exerted by the graft upon the body passageway could cause rupturing of the body passageway.

Another alternative to conventional vascular surgery has been percutaneous balloon dilation of elastic vascular stenoses, or blockages, through use of a catheter

mounted angioplasty balloon. In this procedure, the angioplasty balloon is inflated within the stenosed vessel, or body passageway, in order to shear and disrupt the wall components of the vessel to obtain an enlarged lumen. With respect to arterial atherosclerotic lesions, the relatively incompressible plaque remains unaltered, while the more elastic medial and adventitial layers of the body passageway stretch around the plaque. This process produces dissection, or a splitting and tearing, of the body passageway wall layers, wherein the intima, or internal surface of the artery or body passageway, suffers fissuring. This dissection forms a "flap" of underlying tissue which may reduce the blood flow through the lumen, or block the lumen. Typically, the distending intraluminal pressure within the body passageway can hold the disrupted layer, or flap, in place. If the intimal flap created by the balloon dilation procedure is not maintained in place against the expanded intima, the intimal flap can fold down into the lumen and close off the lumen, or may even become detached and enter the body passageway. When the intimal flap closes off the body passageway, immediate surgery is necessary to correct this problem.

Although the balloon dilation procedure is typically conducted in the catheterization lab of a hospital, because of the foregoing problem, it is always necessary to have a surgeon on call should the intimal flap block the blood vessel or body passageway. Further, because of the possibility of the intimal flap tearing away from the blood vessel and blocking the lumen, balloon dilations cannot be performed upon certain critical body passageways, such as the left main coronary artery, which leads into the heart. If an intimal flap formed by a balloon dilation procedure abruptly comes down and closes off a critical body passageway, such as the left main coronary artery, the patient could die before any surgical procedures could be performed.

Additional disadvantages associated with balloon dilation of elastic vascular stenoses is that many fail because of elastic recoil of the stenotic lesion. This usually occurs due to a high fibrocollagenous content in the lesion and is sometimes due to certain mechanical characteristics of the area to be dilated. Thus, although the body passageway may initially be successfully expanded by a balloon dilation procedure, subsequent, early restenosis can occur due to the recoil of the body passageway wall which decreases the size of the previously expanded lumen of the body passageway. For example, stenoses of the renal artery at the ostium are known to be refractory to balloon dilation because the dilating forces are applied to the aortic wall rather than to the renal artery itself. Vascular stenoses caused by neointimal fibrosis, such as those seen in dialysis-access fistulas, have proved to be difficult to dilate, requiring high dilating pressures and larger balloon diameters. Similar difficulties have been observed in angioplasties of graft-artery anastomotic strictures and postarterectomy recurrent stenoses. Percutaneous angioplasty of Takayasu arteritis and neurofibromatosis arterial stenoses may show poor initial response and recurrence which is believed due to the fibrotic nature of these lesions.

Accordingly, prior to the development of the present invention, there has been no expandable intraluminal vascular graft, and method and apparatus for expanding the lumen of a body passageway, which: prevents recurrence of stenoses in the body passageway; can be

utilized for critical body passageways, such as the left main coronary artery of a patient's heart; prevents recoil of the body passageway wall; and allows the intraluminal graft to be expanded to a variable size to prevent migration of the graft away from the desired location; and to prevent rupturing of the body passageway by the expanded graft. Therefore, the art has sought an expandable intraluminal vascular graft, and method and apparatus for expanding the lumen of a body passageway which: prevents recurrence of stenoses in the body passageway; is believed to be able to be utilized in critical body passageways, such as the left main coronary artery of the heart; prevents recoil of the body passageway; and can be expanded to a variable size within the body passageway to prevent migration of the graft away from the desired location; and to prevent rupturing of the body passageway by the expanded graft.

### SUMMARY OF THE INVENTION

In accordance with the invention the foregoing advantages have been achieved through the present expandable intraluminal vascular graft. The present invention includes a tubular shaped member having first and second ends and a wall surface disposed between the first and second ends, the wall surface being formed by a plurality of intersecting elongate members, at least some of the elongate members intersecting with one another intermediate the first and second ends of the tubular shaped member; the tubular shaped member having a first diameter which permits intraluminal delivery of the tubular shaped member into a body passageway having a lumen; and the tubular shaped member having a second, expanded diameter, upon the application from the interior of the tubular shaped member of a radially, outwardly extending force, which second diameter is variable and dependent upon the amount of force applied to the tubular shaped member, whereby the tubular shaped member may be expanded to expand the lumen of the body passageway.

A further feature of the present invention is that the plurality of elongate members may be a plurality of wires, and the wires may be fixedly secured to one another where the wires intersect with one another. An additional feature of the present invention is that the plurality of elongate members may be a plurality of thin bars which are fixedly secured to one another where the bars intersect with one another. A further feature of the present invention is that the tubular shaped member may have a biologically inert coating on its wall surface, and the coating may include a means for anchoring the tubular shaped member to the body passageway.

In accordance with the invention, the foregoing advantages have also been achieved through the present method for expanding the lumen of a body passageway. The method of the present invention comprises the steps of: inserting an intraluminal graft, disposed upon a catheter, into the body passageway until it is disposed adjacent a desired location within the body passageway; and expanding a portion of the catheter to cause the intraluminal graft to radially expand outwardly into contact with the body passageway until the lumen of the body passageway at the desired location of the body passageway has been expanded, whereby the intraluminal graft prevents the body passageway from collapsing and decreasing the size of the expanded lumen.

A further feature of the present invention is that the portion of the catheter in contact with the intraluminal graft may be collapsed, and the catheter removed from

the body passageway. A further feature of the present invention is that a catheter having an expandable, inflatable portion associated therewith may be utilized; and expansion of the intraluminal graft and the portion of the catheter is accomplished by inflating the expandable, inflatable portion of the catheter.

A further feature of the present invention is that a wire mesh tube may be utilized as the intraluminal graft, the wire mesh tube having a first predetermined, collapsed diameter which permits the tube to be inserted within the body passageway at and delivered to the desired location. Another feature of the present invention is that the wire mesh tube may be expanded to a second diameter within the body passageway; the second, expanded diameter being variable and determined by the desired expanded internal diameter of the body passageway, whereby the expanded wire mesh tube will not migrate from the desired location within the body passageway and the expansion of the intraluminal graft does not cause a rupture of the body passageway.

In accordance with the invention, the foregoing advantages have also been achieved through the present apparatus for intraluminally reinforcing a body passageway. The present invention includes: an expandable, tubular shaped prosthesis having first and second ends and a wall surface disposed between the first and second ends, the wall surface being formed by a plurality of intersecting elongate members; and a catheter, having an expandable, inflatable portion associated therewith and including means for mounting and retaining the expandable tubular shaped prosthesis on the expandable, inflatable portion, whereby upon inflation of the expandable, inflatable portion of the catheter, the prosthesis is forced radially into contact with the body passageway. A further feature of the present invention is that the mounting and retaining means may comprise a retainer ring member disposed on the catheter adjacent the expandable, inflatable portion and adjacent each end of the expandable, tubular shaped prosthesis.

The expandable intraluminal vascular graft, method for expanding the lumen of a body passageway, and apparatus for intraluminally reinforcing a body passageway of the present invention, when compared with previously proposed prior art intraluminal grafts, methods for implanting them, and balloon dilation techniques have the advantages of: preventing recurrence of stenoses; is believed to permit implantation of grafts in critical body passageways, such as in the left main coronary artery of the heart; prevents recoil of the body passageway; and permits expansion of the graft to a variable size dependent upon conditions within the body passageway.

### BRIEF DESCRIPTION OF THE DRAWINGS

In the drawings:

FIG. 1A is a perspective view of an expandable intraluminal vascular graft, or prosthesis for a body passageway, having a first diameter which permits delivery of the graft, or prosthesis, into a body passageway;

FIG. 1B is a perspective view of the graft, or prosthesis, of FIG. 1A, in its expanded configuration when disposed within a body passageway;

FIG. 2A is a perspective view of another embodiment of an expandable intraluminal vascular graft, or prosthesis for a body passageway, having a first diameter which permits intraluminal delivery of the graft, or prosthesis, into a body passageway;

FIG. 2B is a perspective view of the graft, or prosthesis, of FIG. 2A, shown in its expanded configuration when disposed within a body passageway;

FIG. 3 is a cross-sectional view of an apparatus for intraluminally reinforcing a body passageway, or for expanding the lumen of a body passageway, illustrating a prosthesis, or intraluminal vascular graft, in the configurations shown in FIGS. 1A and 2A;

FIG. 4 is a cross-sectional view of the apparatus for intraluminally reinforcing a body passageway, or for expanding the lumen of a body passageway, with a graft, or prosthesis, in the configurations shown in FIGS. 1B and 2B.

When the invention will be described in connection with the preferred embodiment, it will be understood that it is not intended to limit the invention to that embodiment. On the contrary, it is intended to cover all alternatives, modifications, and equivalents, as may be included within the spirit and scope of the invention as defined by the appended claims.

#### DETAILED DESCRIPTION OF THE INVENTION

In FIGS. 1A and 2A, an expandable intraluminal vascular graft, or expandable prosthesis for a body passageway, 70 is illustrated. It should be understood that the terms "expandable intraluminal vascular graft" and "expandable prosthesis" are interchangeably used to some extent in describing the present invention, insofar as the methods, apparatus, and structures of the present invention may be utilized not only in connection with an expandable intraluminal vascular graft for expanding partially occluded segments of a blood vessel, or body passageway, but may also be utilized for many other purposes as an expandable prosthesis for many other types of body passageways. For example, expandable prostheses 70 may also be used for such purposes as: (1) supportive graft placement within blocked arteries opened by transluminal recanalization, but which are likely to collapse in the absence of an internal support; (2) similar use following catheter passage through mediastinal and other veins occluded by inoperable cancers; (3) reinforcement of catheter created intrahepatic communications between portal and hepatic veins in patients suffering from portal hypertension; (4) supportive graft placement of narrowing of the esophagus, the intestine, the ureters, the urethra; and (5) supportive graft reinforcement of reopened and previously obstructed bile ducts. Accordingly, use of the term "prosthesis" encompasses the foregoing usages within various types of body passageways, and the use of the term "intraluminal vascular graft" encompasses use for expanding the lumen of a body passageway. Further, in this regard, the term "body passageway" encompasses any duct within the human body, such as those previously described, as well as any vein, artery, or blood vessel within the human vascular system.

Still with reference to FIG. 1A, the expandable intraluminal vascular graft, or prosthesis, 70 is shown to generally comprise a tubular shaped member 71 having first and second ends 72, 73 and a wall surface 74 disposed between the first and second ends 72, 73. Preferably, the wall surface 74 is formed by a plurality of intersecting elongate members 75, 76 with at least some of the elongate members 75, 76 intersecting with one another intermediate the first and second ends 72, 73 of the tubular shaped member 71, such as shown at intersection points 77. Tubular shaped member 71 has a first

diameter,  $d$ , which, to be hereinafter described in greater detail, permits intraluminal delivery of the tubular shaped member 71 into a body passageway 80 having a lumen (FIG. 3). With reference to FIG. 1B, upon the application from the interior of the tubular shaped member 71 of a radially, outwardly extending force, to be hereinafter described in greater detail, tubular shaped member 71 has a second, expanded diameter,  $d'$ , which second diameter  $d'$  is variable in size and dependent upon the amount of force applied to the tubular shaped member 71.

With reference to FIGS. 1A and 1B, elongate members 75, 76, which form wall surface 74 of tubular shaped member 71, may be any suitable material which is compatible with the human body and the bodily fluids (not shown) with which the vascular graft, or prosthesis, 70 may come into contact. Elongate members 75, 76 must also be made of a material which has the requisite strength and elasticity characteristics to permit the tubular shaped member 71 to be expanded from the configuration shown in FIG. 1A to the configuration shown illustrated in FIG. 1B and further to permit the tubular shaped member 71 to retain its expanded configuration with the enlarged diameter  $d'$  shown in FIG. 1B. Suitable materials for the fabrication of tubular shaped member 71 would include silver, tantalum, stainless steel, gold, titanium or any suitable plastic material having the requisite characteristics previously described. Preferably, elongate members 75, 76 are fabricated from stainless steel. Preferably, the elongate members 75, 76 illustrated in FIGS. 1A and 1B are small diameter stainless steel wires having a cylindrical cross-section. It should of course be understood that each elongate member 75, 76, could have other cross-sectional configurations, such as triangular, square, rectangular, hexagonal, etc. Further, it is preferable that the plurality of elongate members 75, 76 are fixedly secured to one another where the elongate members 75, 76 intersect with one another, such as at the intersection points 77. Elongate members 75, 76 could be fixedly secured to one another in any conventional manner, such as by welding, soldering, or gluing, such as with a suitable epoxy glue; however, it is preferred that the intersection points 77 are soldered with silver. By fixedly securing the elongate members 75, 76, to one another, tubular member 71 is provided with a relatively high resistance to radial collapse, and the tubular shaped member 71 has the ability to retain its enlarged diameter,  $d'$ , as shown in FIG. 1B. Preferably, tubular shaped member 71 is made of continuous, stainless steel wire woven in a criss-crossed tubular pattern to form what can be generally described as a wire mesh tube.

When fabricating tubular shaped member, or wire mesh tube, 71, it can be initially fabricated in the configuration shown in FIG. 1A with diameter,  $d$ . Alternatively, it can be fabricated with a diameter which is larger than initial diameter  $d$  and after fabrication, tubular shaped member 71 could be carefully collapsed to have diameter  $d$  shown in FIG. 1A. During the collapsing of tubular shaped member, or wire mesh tube, 71, care must be taken to insure that overlapping of adjacent elongate members 75, 76 is avoided. It should of course be understood that upon expansion of tubular shaped member, or wire mesh tube, 71 into the configuration shown in FIG. 1B, the distance between first and second ends 72 and 73 will of course decrease.

With reference now to FIGS. 2A and 2B, another embodiment of expandable intraluminal vascular graft,

or prosthesis, 70, is illustrated. The same reference numerals are utilized and are applicable for elements previously described in FIGS. 1A and 1B. The intraluminal vascular graft, or prosthesis, 70 of FIGS. 2A and 2B differs from that previously described in connection with FIGS. 1A and 1B, in that the plurality of elongate members 75 and 76 are a plurality of thin bars 78, 79 which are preferably fixedly secured to one another where the bars 78, 79 intersect with one another. Bars 78, 79 preferably have a thin, rectangular cross-sectional configuration, and may be joined to one another in any conventional manner, such as by welding, brazing, soldering, or may be formed integral with one another. Preferably, tubular shaped member 71 is initially a thin-walled stainless steel tube, and the openings 82 between the intersecting bars 78 and 79 are formed by a conventional etching process, such as electromechanical or laser etching, whereby the resultant structure is a tubular shaped member 71 having a plurality of intersecting elongate members 78, 79. The embodiment of graft, or prosthesis, 70 of FIG. 2A, likewise can assume an expanded configuration as shown in FIG. 2B and as previously described in connection with FIG. 1B, upon the application from the interior of the tubular shaped member 71 of a radially, outwardly extending force. It should be further understood that the embodiment of vascular graft, or prosthesis, 70 of FIGS. 2A and 2B, could also be generally described as a wire mesh tube.

With reference now to FIGS. 3 and 4, the methods and apparatus of the present invention will be described in greater detail. Once again, it should be understood that the methods and apparatus of the present invention are useful not only for expanding the lumen of a body passageway, such as an artery, vein, or blood vessel of the human vascular system, but are also useful to perform the previously described procedures to intraluminally reinforce other body passageways or ducts, as previously described. Still with reference to FIGS. 3 and 4, an expandable intraluminal vascular graft, or prosthesis, 70, which may be of the type previously described in connection with FIGS. 1A or 2A, is disposed or mounted upon a catheter 83. Catheter 83 has an expandable, inflatable portion 84 associated therewith. Catheter 83 includes means for mounting and retaining 85 the expandable intraluminal vascular graft, or prosthesis, 70 on the expandable, inflatable portion 84 of catheter 83. Preferably, the mounting and retaining means 85 comprises retainer ring members 86 disposed on the catheter 83 adjacent the expandable inflatable portion 84 of catheter 83; and a retainer ring member 86 is disposed adjacent each end 72, 73 of the expandable intraluminal vascular graft, or prosthesis, 70. Preferably, as seen in FIG. 3, while retainer ring members are formed integral with catheter 83, and the retainer ring member 86 adjacent the leading tip 87 of catheter 83 slopes upwardly and away from catheter tip 87 in order to protect and retain graft or prosthesis, 70 as it is inserted into the lumen 81 of body passageway 80, as to be hereinafter described in greater detail. The remaining retainer ring member 86 as shown in FIG. 3, slopes downwardly away from tip 87 of catheter 83, to insure easy removal of catheter 83 from body passageway 80. After expandable intraluminal graft, or prosthesis, 70 has been disposed upon catheter 83, in the manner previously described, the graft, or prosthesis, 70 and catheter 83 are inserted within a body passageway 80 by catheterization of the body passageway 80 in a conventional manner.

In a conventional manner, the catheter 83 and graft, or prosthesis, 70 are delivered to the desired location within the body passageway 80, whereat it is desired to expand the lumen 81 of body passageway 80 via intraluminal graft 70, or where it is desired to implant prosthesis 70. Fluoroscopy, and/or other conventional techniques may be utilized to insure that the catheter 83 and graft, or prosthesis, 70 are delivered to the desired location within the body passageway. Prosthesis, or graft, 70 are then expanded by expanding the expandable, inflatable portion 84 of catheter 83, whereby the prosthesis, or graft, 70 is forced radially, outwardly into contact with the body passageway 80 as shown, in FIG. 4. In this regard, the expandable, inflatable portion of catheter 83 may be a conventional angioplasty balloon 88. After the desired expansion of prosthesis, or graft, 70 has been accomplished, angioplasty balloon 88 may be collapsed, or deflated, and the catheter 83 may be removed in a conventional manner from body passageway 80. If desired, as seen in FIG. 3, catheter 83, having graft or prosthesis, 70 disposed thereon, may be initially encased in a conventional Teflon™ sheath 89, which is pulled away from prosthesis, or graft, 70, prior to expansion of the prosthesis, or graft, 70.

Still with reference to FIGS. 3 and 4, it should be noted that the tubular shaped member 71 of prosthesis, or graft, 70 initially has the first predetermined, collapsed diameter  $d$  as described in connection with FIGS. 1A and 2A, in order to permit the insertion of the wire mesh tube, or tubular shaped member, 71 into the body passageway 80 as previously described. When it is desired to implant prosthesis 70 within a body passageway 80 for the purposes previously described, the wire mesh tube, or prosthesis 70, is expanded to the second diameter  $d'$  and the second, expanded diameter  $d'$  is variable and determined by the internal diameter of the body passageway 80, as shown in FIG. 4. Accordingly, the expanded prosthesis 70, upon deflation of angioplasty balloon 88 will not be able to migrate from the desired location within the body passageway 80, nor will the expansion of the prosthesis 70 be likely to cause a rupture of the body passageway 80.

When it is desired to use expandable intraluminal graft 70 to expand the lumen 81 of a body passageway 80 having an area of stenosis, the expansion of intraluminal vascular graft 70 by angioplasty balloon 88, allows controlled dilation of the stenotic area and, at the same time controlled expansion of the vascular graft 70, whereby vascular graft 70 prevents the body passageway 80 from collapsing and decreasing the size of the previously expanded lumen 81. Once again, the second, expanded diameter  $d'$  of intraluminal vascular graft 70, as shown in FIG. 4 is variable and determined by the desired expanded internal diameter of body passageway 80. Thus, the expandable intraluminal graft 70 will not migrate away from the desired location within the body passageway 80 upon deflation of angioplasty balloon 88, nor will the expansion of intraluminal graft 70 likely cause a rupture of body passageway 80. Further, should an intimal flap, or fissure, be formed in body passageway 80 at the location of graft 70, graft 70 will insure that such an intimal flap will not be able to fold inwardly into body passageway 80, nor tear loose and flow through body passageway 80. In the situation of utilizing graft 70 in the manner previously described to expand the lumen of a portion of the left main artery, it is believed that the intimal flap will be unable to enter the heart and cause the death of the patient.

Because it is only necessary to inflate angioplasty balloon 88 one time in order to expand graft 70, it is believed that a greater amount of endothelium, or inner layer of the intima, or inner surface of the body passageway, will be preserved, insofar as the extent of endothelial denudation during transluminal angioplasty is proportional to the balloon inflation time. Further, in theory, the amount of preserved endothelium should be large because in the expanded configuration of graft 70, potentially 80% of the endothelium is exposed through openings 82 of graft 70. It is further believed that intact patches of endothelium between the elongate members 75, 76, 78, 79 of graft 70 may result in a rapid, multicentric endothelialization pattern as shown by experimental studies.

It is to be understood that the invention is not limited to the exact details of construction, operation, exact materials or embodiment shown and described, as obvious modifications and equivalents will be apparent to one skilled in the art. For example, the means for expanding the prosthesis or graft could be a plurality of hydraulically actuated rigid members disposed on a catheter, or a plurality of angioplasty balloons could be utilized to expand the prosthesis or graft. Accordingly, the invention is therefore to be limited only by the scope of the appended claims.

What is claimed is:

1. A method for implanting a prosthesis within a body passageway comprising the steps of:

disposing the prosthesis upon a catheter;  
inserting the prosthesis and catheter within the body passageway by catheterization of said body passageway; and

providing controllable expansion of the prosthesis at a desired location within the body passageway by expanding a portion of the catheter associated with the prosthesis to force the prosthesis radially outwardly into contact with the body passageway, by deforming a portion of the prosthesis with a force in excess of the elastic limit of the portion of the prosthesis, to implant the prosthesis within the body passageway.

2. The method of claim 1, further including the steps of: collapsing the portion of the catheter associated with the prosthesis, and removing the catheter from the body passageway.

3. The method of claim 1, including the steps of: utilizing a catheter having an expandable, inflatable portion associated therewith; and the controllable expansion of the prosthesis and the portion of the catheter is accomplished by inflating the expandable, inflatable portion of the catheter.

4. The method of claim 1, including the step of: utilizing a wire mesh tube as the prosthesis, the wire mesh tube having a first predetermined collapsed diameter which permits the tube to be disposed upon the catheter and inserted into the body passageway.

5. The method of claim 4, wherein tantalum is utilized for the wire mesh tube.

6. The method of claim 4, wherein the wire mesh tube is expanded to a second diameter within the body passageway; the second, expanded diameter being variable and determined by the internal diameter of the body passageway, whereby the expanded wire mesh tube will not migrate from the desired location within the body passageway and the expansion of the prosthesis does not cause a rupture of the body passageway.

7. A method for expanding the lumen of a body passageway comprising the steps of:

inserting an intraluminal graft, disposed upon a catheter, into the body passageway until it is disposed adjacent a desired location within the body passageway; and

expanding a portion of the catheter to provide controllable expansion of the intraluminal graft radially, outwardly into contact with the body passageway, by deforming a portion of the intraluminal graft with a force in excess of the elastic limit of the portion of the prosthesis, until the lumen of the body passageway at the desired location in the body passageway has been expanded, whereby the intraluminal graft prevents the body passageway from collapsing and decreasing the size of the expanded lumen, and the intraluminal graft remains in the passageway.

8. The method of claim 7, further including the steps of: collapsing the portion of the catheter in contact with the intraluminal graft and removing the catheter from the body passageway.

9. The method of claim 7, including the steps of: utilizing a catheter having an expandable, inflatable portion associated therewith; and the controllable expansion of the intraluminal graft and the portion of the catheter is accomplished by inflating the expandable, inflatable portion of the catheter.

10. The method of claim 7, including the step of: utilizing a wire mesh tube as the intraluminal graft, the wire mesh tube having a first predetermined, collapsed diameter which permits the tube to be inserted within the body passageway at the desired location.

11. The method of claim 10, wherein tantalum is utilized for the wire mesh tube.

12. The method of claim 10, wherein the wire mesh tube is expanded to a second diameter within the body passageway; the second, expanded diameter being variable and determined by the desired expanded internal diameter of the body passageway, whereby the expanded wire mesh tube will not migrate from the desired location within the body passageway and the expansion of the intraluminal graft does not cause a rupture of the body passageway.

13. An expandable intraluminal vascular graft, comprising:

a tubular shaped member having first and second ends and a wall surface disposed between the first and second ends, the wall surface being formed by a plurality of intersecting elongate members, at least some of the elongate members intersecting with one another intermediate the first and second ends of the tubular shaped member;

the tubular shaped member having a first diameter which permits intraluminal delivery of the tubular shaped member into a body passageway having a lumen; and

the tubular shaped member having a second, expanded diameter, upon the application from the interior of the tubular shaped member of a radially, outwardly extending force, which second diameter is variable and controlled by the amount of force applied to the tubular shaped member, at least some of the elongate members being deformed by the radially, outwardly extending force, to retain the tubular shaped member with the second, expanded diameter, whereby the tubular shaped member may



be expanded to expand the lumen of the body passageway and remain therein.

14. The expandable intraluminal vascular graft of claim 13, wherein the plurality of elongate members are a plurality of wires, and the wires are fixedly secured to one another where the wires intersect with one another.

15. The expandable intraluminal vascular graft of claim 14, wherein the plurality of elongate members are a plurality of tantalum wires.

16. The expandable intraluminal vascular graft of claim 13 wherein the plurality of elongate members are a plurality of thin bars which are fixedly secured to one another where the bars intersect with one another.

17. The expandable intraluminal vascular graft of claim 16, wherein the plurality of elongate members are a plurality of thin tantalum bars.

18. An expandable prosthesis for a body passageway, comprising:

a tubular shaped member having first and second ends and a wall surface disposed between the first and second ends, the wall surface being formed by a plurality of intersecting elongate members, at least some of the elongate members intersecting with one another intermediate the first and second ends of the tubular shaped member;

the tubular shaped member having a first diameter which permits intraluminal delivery of the tubular shaped member into a body passageway having a lumen; and

the tubular shaped member having a second, expanded diameter, upon the application from the interior of the tubular shaped member of a radially, outwardly extending force, which second diameter is variable and controlled by the amount of force applied to the tubular shaped member, at least some of the elongate members being deformed by the radially, outwardly extending force, to retain the tubular shaped member with the second, expanded diameter, whereby the tubular shaped member may be expanded to expand the lumen of the body passageway and remain therein.

19. The expandable prosthesis for a body passageway of claim 18, wherein the plurality of elongate members are a plurality of wires and the wires are fixedly secured to one another where the wires intersect with one another.

20. The expandable prosthesis of claim 19, wherein the plurality of elongate members are a plurality of tantalum wires.

21. The expandable prosthesis for a body passageway of claim 18, wherein the plurality of elongate members are a plurality of thin bars which are fixedly secured to one another where the bars intersect with one another.

22. The expandable prosthesis of claim 21, wherein the plurality of elongate members are a plurality of thin tantalum bars.

23. An apparatus for intraluminally reinforcing a body passageway, comprising:

an expandable, tubular shaped prosthesis having first and second ends, and a wall surface disposed between the first and second ends, the wall surface being formed by a plurality of intersecting elongate members, the expansion of the prosthesis being controllable; and

a catheter, having an expandable, inflatable portion associated therewith and including means for mounting and retaining the expandable, tubular shaped prosthesis on the expandable, inflatable portion,

whereby upon inflation of the expandable, inflatable portion of the catheter, the prosthesis is forced radially outwardly into contact with the body passageway to remain therein, and the expansion of the prosthesis is controlled by the expansion of the inflatable portion of the catheter.

24. The apparatus of claim 23, wherein the plurality of intersecting elongate members are a plurality of intersecting elongate, tantalum members.

25. The apparatus of claim 23, wherein the mounting and retaining means comprises retainer ring members disposed on the catheter adjacent the expandable, inflatable portion and adjacent each end of the expandable, tubular shaped prosthesis.

26. An apparatus for expanding the lumen of a body passageway comprising:

an expandable intraluminal vascular graft having first and second ends, and a wall surface disposed between the first and second ends, the wall surface being formed by a plurality of intersecting elongate members, the expansion of the vascular graft being controllable; and

a catheter, having an expandable, inflatable portion associated therewith and including means for mounting and retaining the expandable intraluminal vascular graft on the expandable, inflatable portion

whereby upon inflation of the expandable, inflatable portion of the catheter, the intraluminal vascular graft is forced radially outwardly into contact with the body passageway to remain therein, and the expansion of the vascular graft is controlled by the expansion of the inflatable portion of the catheter.

27. The apparatus of claim 26, wherein the plurality of intersecting elongate members are a plurality of intersecting elongate, tantalum members.

28. The apparatus of claim 26, wherein the mounting and retaining means comprises retainer ring members disposed on the catheter adjacent the expandable, inflatable portion and adjacent each end of the expandable intraluminal vascular graft.

\* \* \* \* \*

UNITED STATES PATENT AND TRADEMARK OFFICE  
**CERTIFICATE OF CORRECTION**

PATENT NO. : B1-4,733,665  
DATED : January 11, 1994  
INVENTOR(S) : Julio C. Palmaz

It is certified that error appears in the above-identified patent and that said Letters Patent is hereby corrected as shown below:

Column 2

In Claim 29, Line 2, delete "cather", and insert--catheter--.

In Claim 29, Line 2, delete "catheri-", and insert--catheteri-

---

In Claim 30, Line 3, delete "catherization", and insert--  
catheterization--.

Signed and Sealed this  
Sixth Day of December, 1994

Attest:



BRUCE LEHMAN

Attesting Officer

Commissioner of Patents and Trademarks

UNITED STATES PATENT AND TRADEMARK OFFICE

CERTIFICATE EXTENDING PATENT TERM  
UNDER 35 U.S.C. § 156

PATENT NO.: 4,733,665  
DATED: March 29, 1988  
INVENTOR: Julio C. Palmaz  
PATENT OWNER: Expandable Grafts Partnership

This is to certify that there has been presented to the

COMMISSIONER OF PATENTS AND TRADEMARKS

an application under 35 U.S.C. § 156 for an extension of the patent term. Since it appears that the requirements of the law have been met, this certificate extends the term of the patent for the period of

182 DAYS

with all rights pertaining thereto as provided by 35 U.S.C. § 156(b).



I have caused the seal of the Patent and Trademark Office to be affixed this 20th day of May 1993.

A handwritten signature in cursive script that reads "Michael K. Kirk".

Michael K. Kirk  
Acting Commissioner of Patents and Trademarks



US004733665B1

# REEXAMINATION CERTIFICATE (2182nd)

United States Patent [19]

[11] B1 4,733,665

Palmaz

[45] Certificate Issued Jan. 11, 1994

[54] EXPANDABLE INTRALUMINAL GRAFT, AND METHOD AND APPARATUS FOR IMPLANTING AN EXPANDABLE INTRALUMINAL GRAFT

[75] Inventor: Julio C. Palmaz, San Antonio, Tex.

[73] Assignee: Expandable Grafts Partnership, Antonio, Tex.

**Reexamination Requests:**

No. 90/002,493, Oct. 23, 1991  
No. 90/002,638, Feb. 12, 1992

**Reexamination Certificate for:**

Patent No.: 4,733,665  
Issued: Mar. 29, 1988  
Appl. No.: 796,009  
Filed: Nov. 7, 1985

- [51] Int. Cl.<sup>5</sup> ..... A61M 29/00
- [52] U.S. Cl. .... 606/108; 606/191;  
604/96; 604/104; 623/1
- [58] Field of Search ..... 606/108, 191, 198

[56] **References Cited**

**U.S. PATENT DOCUMENTS**

- 3,657,744 4/1972 Ersek .
- 4,140,126 2/1979 Choudhury .
- 4,299,226 11/1981 Banka .
- 4,328,811 5/1982 Fogarty .
- 4,338,942 7/1982 Fogarty .
- 4,403,612 9/1983 Fogarty .
- 4,503,569 3/1985 Dotter .
- 4,560,374 12/1985 Hammerslag .

**FOREIGN PATENT DOCUMENTS**

WO83/03752 11/1983 PCT Int'l Appl. .

**OTHER PUBLICATIONS**

Program Abstract for the 1984 Annual Meeting of the Radiological Society of North America: Palmaz et al., "Expandable Intraluminal Graft: A Preliminary Study"—distributed to the public Oct. 1984.

Palmaz et al., "Expandable Intraluminal Graft: A Preliminary Study", Radiology, 1985: 156: 73-77.

Palmaz et al., "Atherosclerotic Rabbit Aortas: Expandable Intraluminal Grafting", Radiology 1986: 160:723.

Abstract of Journal of Biomedical Materials Research, Jul. 1979, 13(4) pp. 631-643.

Abstract of Journal of Orthodontistry, May 1983, 83(5), pp. 391-407.

Dotter, "Transluminally-placed Coilspring Endarterial Tube Grafts", Investigative radiology, Sep.-Oct. 1969, vol. 4, pp. 329-332.

Maass et al., "Radiological Follow-up of Transluminally Inserted Vascular Endoprostheses: An Experimental Study Using Expanding Spirals", Radiology 1984: 152: 659-663.

Dorland's Illustrated Medical Dictionary, 26th Ed., 1981, pp. 675 and 759.

"The Experimental Use of Steel Mesh Tubes For The Replacement of Arterial Segments" AMA Archives of Surgery, Jan. 1956, vol. 72, pp. 69-75, B. G. Lary et al. Radiology, vol. 153P (Special Issue—Scientific Program For Nov. RSNA Meeting) p. 329, (Mailed to Public in Oct. of 1984).

Primary Examiner—Michael H. Thaler

[57] **ABSTRACT**

An expandable intraluminal vascular graft is expanded within a blood vessel by an angioplasty balloon associated with a catheter to dilate and expand the lumen of a blood vessel. The graft may be a wire mesh tube.

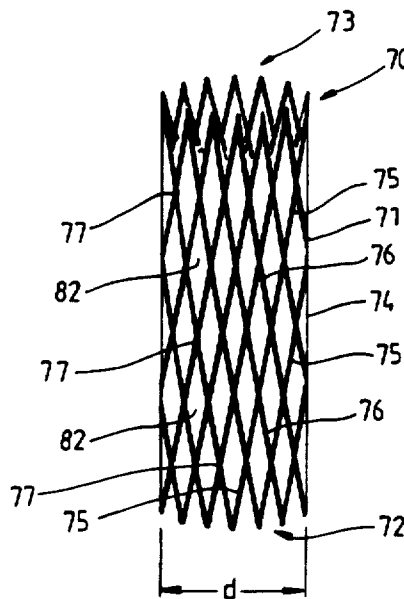

REEXAMINATION CERTIFICATE  
ISSUED UNDER 35 U.S.C. 307

THE PATENT IS HEREBY AMENDED AS  
INDICATED BELOW.

Matter enclosed in heavy brackets [ ] appeared in the patent, but has been deleted and is no longer a part of the patent; matter printed in italics indicates additions made to the patent.

AS A RESULT OF REEXAMINATION, IT HAS  
BEEN DETERMINED THAT:

The patentability of claims 23-28 is confirmed.

Claims 1, 7, 13 and 18 are determined to be patentable as amended.

Claims 2-6, 8-12, 14-17 and 19-22, dependent on an amended claim, are determined to be patentable.

New claims 29-32 are added and determined to be patentable.

1. A method for implanting a prosthesis at a desired location within a body passageway comprising the steps of:

- disposing the prosthesis upon a catheter;
- inserting the prosthesis and catheter within the body passageway by catheterization of said body passageway; [and]
- delivering the catheter and prosthesis through the body passageway to the desired location in the body passageway without surgically exposing the desired location of the body passageway; and
- providing controllable expansion of the prosthesis at [a] the desired location within the body passageway by expanding a portion of the catheter associated with the prosthesis to force the prosthesis radially outwardly into contact with the body passageway, by deforming a portion of the prosthesis with a force in excess of the elastic limit of the portion of the prosthesis, to implant the prosthesis within the body passageway.

7. A method for expanding the lumen of a body passageway comprising the steps of:

- [inserting an intraluminal graft, disposed upon a catheter, into the body passageway until it is disposed adjacent a desired location within the body passageway; and]
- disposing an intraluminal graft upon a catheter;
- inserting the intraluminal graft and catheter within the body passageway by catheterization of the body passageway;
- delivering the intraluminal graft and catheter through the body passageway to a desired location within the body passageway without surgically exposing the desired location of the body passageway; and
- expanding a portion of the catheter to provide controllable expansion of the intraluminal graft radially, outwardly into contact with the body passageway, by deforming a portion of the intraluminal graft with a force in excess of the elastic limit of the portion of the [prosthesis] intraluminal graft, until the lumen of the body passageway at the desired location in the body passageway has been expanded, whereby the intraluminal graft prevents the body passageway from collapsing and decreases

ing the size of the expanded lumen, and the intraluminal graft remains in the body passageway.

13. An expandable intraluminal vascular graft, comprising:

- a tubular shaped member having first and second ends and a smooth outer wall surface, without any narrow, outwardly projecting edges, disposed between the first and second ends, the wall surface being formed by a plurality of intersecting elongate members, at least some of the elongate members intersecting with one another intermediate the first and second ends of the tubular shaped member;
- the tubular shaped member having a first diameter which permits intraluminal delivery of the tubular shaped member into a body passageway having a lumen; and
- the tubular shaped member having a second, expanded diameter and a substantially smooth outer wall surface, without any narrow, outwardly projecting edges, upon the application from the interior of the tubular shaped member of a radially, outwardly extending force, which second diameter is variable and controlled by the amount of force applied to the tubular shaped member, at least some of the elongate members being deformed by the radially, outwardly extending force to retain the tubular shaped member with the second, expanded diameter, whereby the tubular shaped member may be expanded to expand the lumen of the body passageway and remain therein.

18. An expandable prosthesis for a body passageway, comprising:

- a tubular shaped member having first and second ends and a smooth outer wall surface, without any narrow, outwardly projecting edges, disposed between the first and second ends, the wall surface being formed by a plurality of intersecting elongate members, at least some of the elongate members intersecting with one another intermediate the first and second ends of the tubular shaped member;
- the tubular shaped member having a first diameter which permits intraluminal delivery of the tubular shaped member into a body passageway having a lumen; and
- the tubular shaped member having a second, expanded diameter and a substantially smooth outer wall surface, without any narrow outwardly projecting edges, upon the application from the interior of the tubular shaped member of a radially, outwardly extending force, which second diameter is variable and controlled by the amount of force applied to the tubular shaped member, at least some of the elongate members being deformed by the radially, outwardly extending force, to retain the tubular shaped member with the second, expanded diameter, whereby the tubular shaped member may be expanded to expand the lumen of the body passageway and remain therein.

29. The method of claim 1, wherein the prosthesis and catheter are inserted within the body passageway by catheterization through a body orifice.

30. The method of claim 1, wherein the prosthesis and catheter are inserted within the body passageway by percutaneous catheterization of the body passageway.

31. The method of claim 7, wherein the intraluminal graft and catheter are inserted within the body passageway by catheterization through a body orifice.

32. The method of claim 7, wherein the intraluminal graft and catheter are inserted within the body passageway by percutaneous catheterization of the body passageway.

\* \* \* \* \*