



(12) **United States Patent**  
**Nelson et al.**

(10) **Patent No.:** **US 9,795,849 B2**  
(45) **Date of Patent:** **Oct. 24, 2017**

(54) **BALL NET STRUCTURE WITH ALTERABLE BASE**

(71) Applicant: **TRIAD SPORTS, INC.**, Camarillo, CA (US)

(72) Inventors: **David Nelson**, Camarillo, CA (US);  
**John Lucas**, Camarillo, CA (US)

(73) Assignee: **TRIAD SPORTS, INC.**, Camarillo, CA (US)

(\* ) Notice: Subject to any disclaimer, the term of this patent is extended or adjusted under 35 U.S.C. 154(b) by 0 days.

(21) Appl. No.: **15/230,210**

(22) Filed: **Aug. 5, 2016**

(65) **Prior Publication Data**  
US 2017/0056741 A1 Mar. 2, 2017

**Related U.S. Application Data**

(63) Continuation-in-part of application No. 15/068,354, filed on Mar. 11, 2016, which is a continuation of (Continued)

(51) **Int. Cl.**  
**A63B 69/00** (2006.01)  
**A63B 61/00** (2006.01)  
(Continued)

(52) **U.S. Cl.**  
CPC ..... **A63B 69/00** (2013.01); **A63B 61/00** (2013.01); **A63B 63/00** (2013.01); **A63B 71/022** (2013.01);  
(Continued)

(58) **Field of Classification Search**  
CPC . A63B 63/04; A63B 2210/50; A63B 2210/52; A63B 2210/54; A63B 61/02; A63B 61/04; A63B 63/00; A63B 63/004  
(Continued)

(56) **References Cited**

**U.S. PATENT DOCUMENTS**

4,274,632 A 6/1981 Jacobs  
5,080,375 A \* 1/1992 Moosavi ..... A63B 63/004  
473/478

(Continued)

**FOREIGN PATENT DOCUMENTS**

JP 3100716 5/2004  
JP 2011024660 2/2011  
KR 920008138 11/1992

**OTHER PUBLICATIONS**

International Preliminary Report and Written Opinion from PCT/US2012/040557, dated Dec. 12, 2013.

*Primary Examiner* — Mark Graham

(74) *Attorney, Agent, or Firm* — Koppel, Patrick, Heybl & Philpott

(57) **ABSTRACT**

A ball net structure arranged to be portable, collapsible, and able to be configured into different arrangements for different nets and/or different sports-related activities. The ball net structure comprising a base structure including at least one support portion, at least one base extension, and at least one base extension hinge, wherein the at least one support portion and the at least one base extension are coupled to the at least one base extension hinge. At least one rod is removably coupled to the base structure and received by a net, wherein the net is adapted to exert a force on the at least one rod causing the at least one rod to exert a force onto said base structure.

**1 Claim, 13 Drawing Sheets**

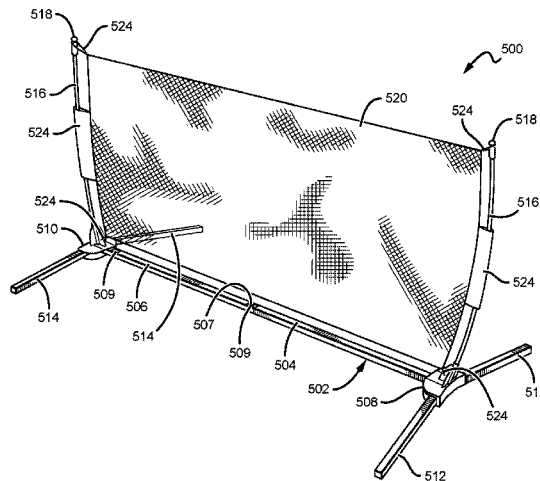

**Related U.S. Application Data**

(56)

**References Cited**

- application No. 13/485,775, filed on May 31, 2012, now Pat. No. 9,283,455.
- (60) Provisional application No. 61/492,010, filed on Jun. 1, 2011, provisional application No. 62/287,356, filed on Jan. 26, 2016.
- (51) **Int. Cl.**  
*A63B 63/00* (2006.01)  
*A63B 71/02* (2006.01)  
*A63B 102/18* (2015.01)
- (52) **U.S. Cl.**  
 CPC ..... *A63B 2071/026* (2013.01); *A63B 2102/18* (2015.10); *A63B 2209/02* (2013.01); *A63B 2210/50* (2013.01); *A63B 2225/055* (2013.01); *A63B 2243/0025* (2013.01)
- (58) **Field of Classification Search**  
 USPC ..... 273/398-402, 395, 396; 473/478, 434, 473/435, 490, 492-495
- See application file for complete search history.

U.S. PATENT DOCUMENTS

5,269,533	A	12/1993	Kellams
5,539,957	A	7/1996	Schmidt
5,816,956	A	10/1998	Ellis et al.
5,839,733	A	11/1998	Meeks et al.
6,371,873	B1	4/2002	Wang
6,511,390	B2	1/2003	Kim
6,716,123	B1	4/2004	Chen
7,371,195	B2	5/2008	Stevens
8,216,092	B2	7/2012	Wennesland
8,216,093	B2	7/2012	Chen
9,283,455	B2 *	3/2016	Nelson ..... A63B 61/00
2003/0153412	A1	8/2003	Duba et al.
2004/0036222	A1	2/2004	Chou
2007/0087869	A1	4/2007	Lin
2007/0281805	A1	12/2007	Hsiao
2010/0304902	A1	12/2010	Holland et al.
2011/0074111	A1	3/2011	Jackson
2011/0230284	A1	9/2011	Simon
2011/0287872	A1	11/2011	Lynch

\* cited by examiner

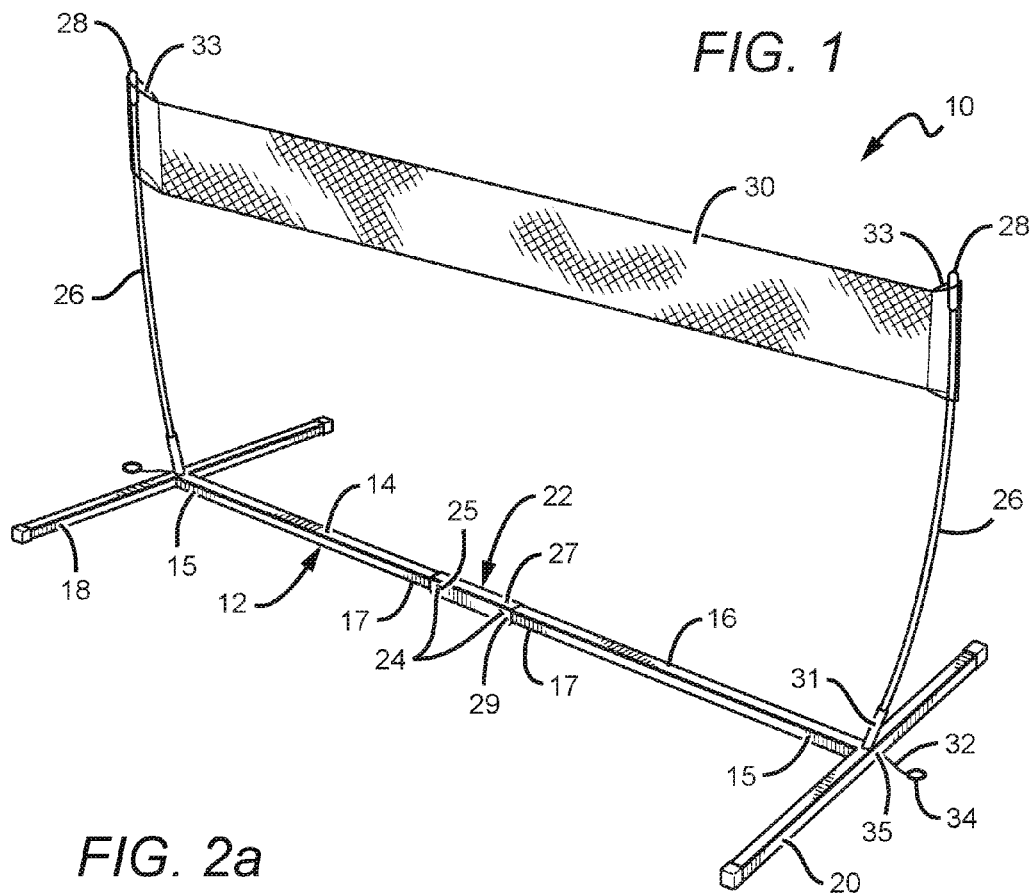

**FIG. 2a**

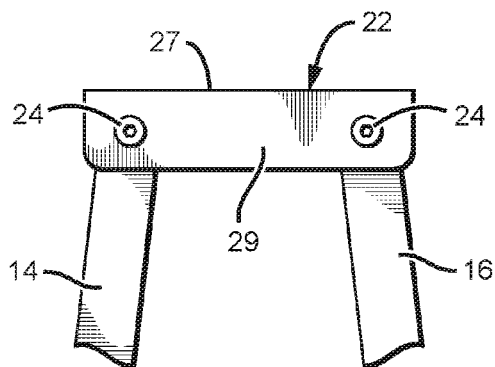

**FIG. 2b**

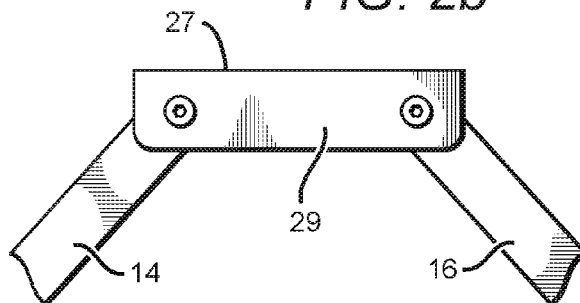

FIG. 2c

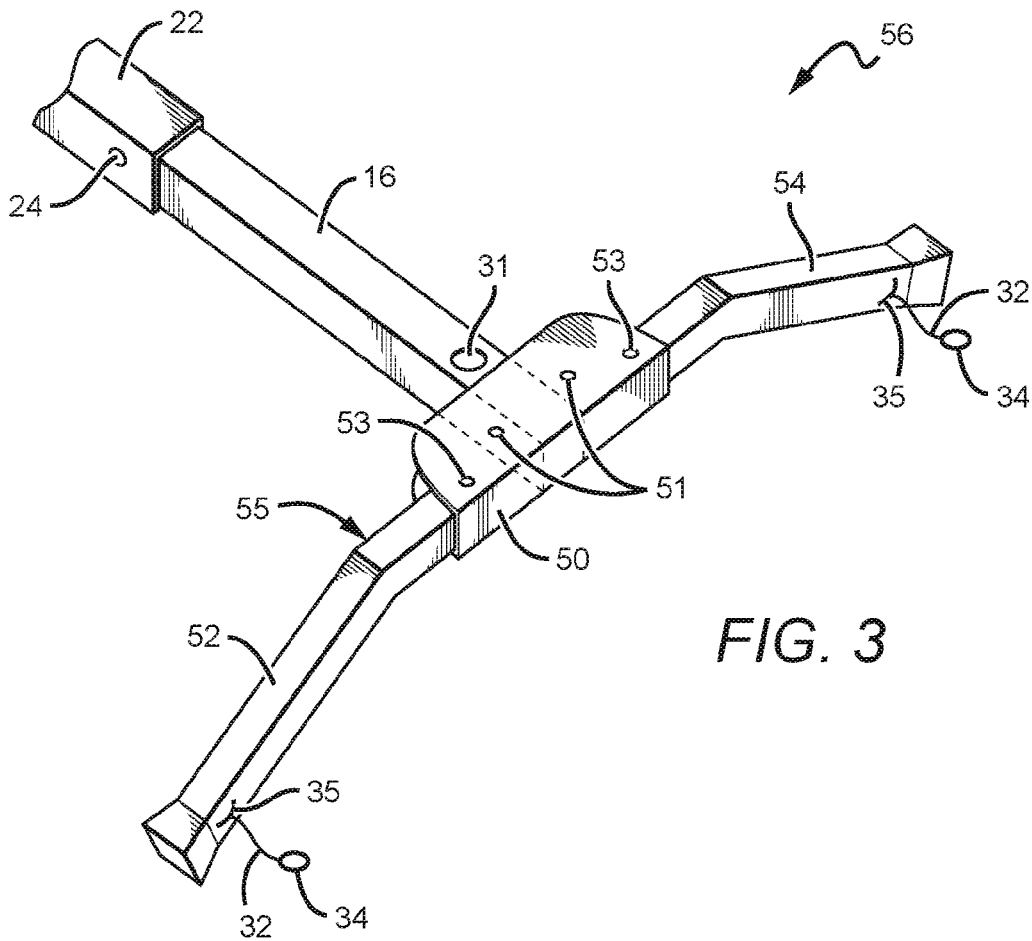
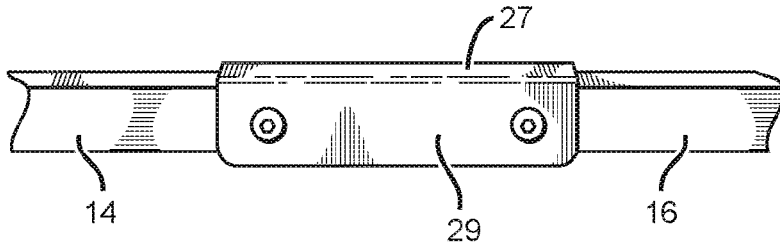

FIG. 3

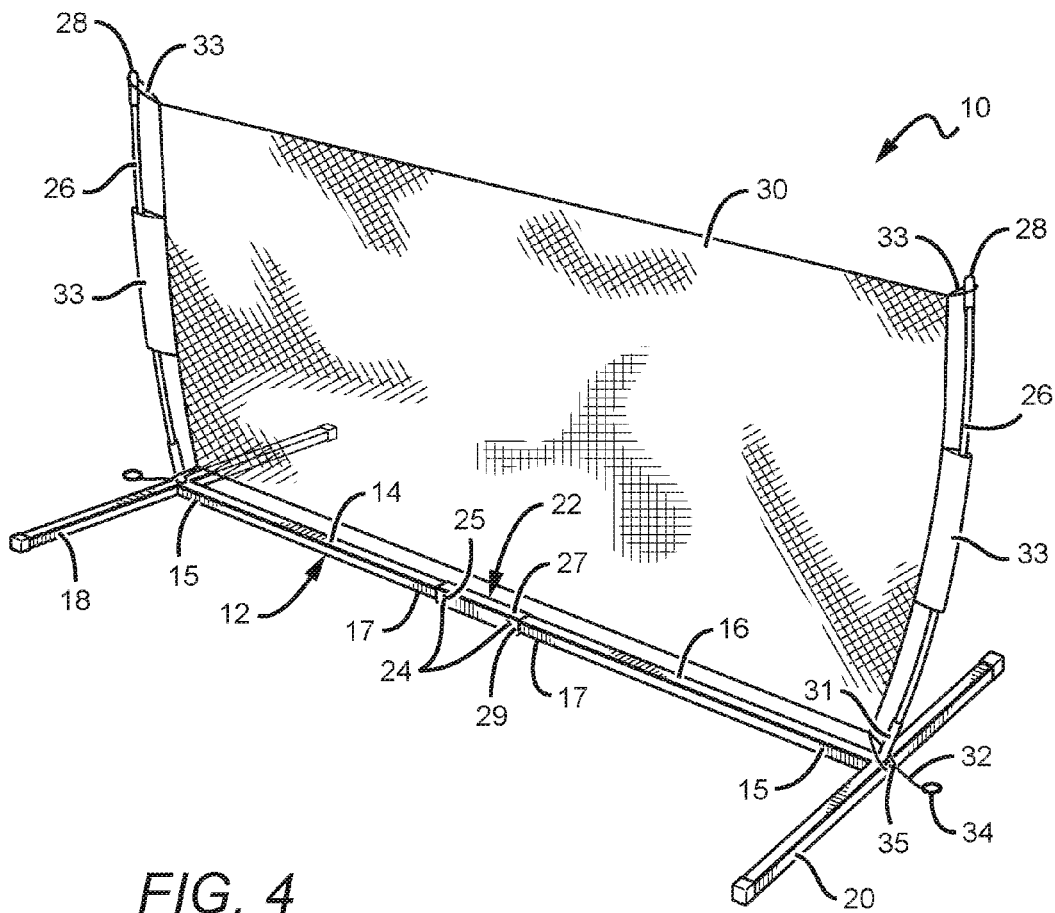

FIG. 4

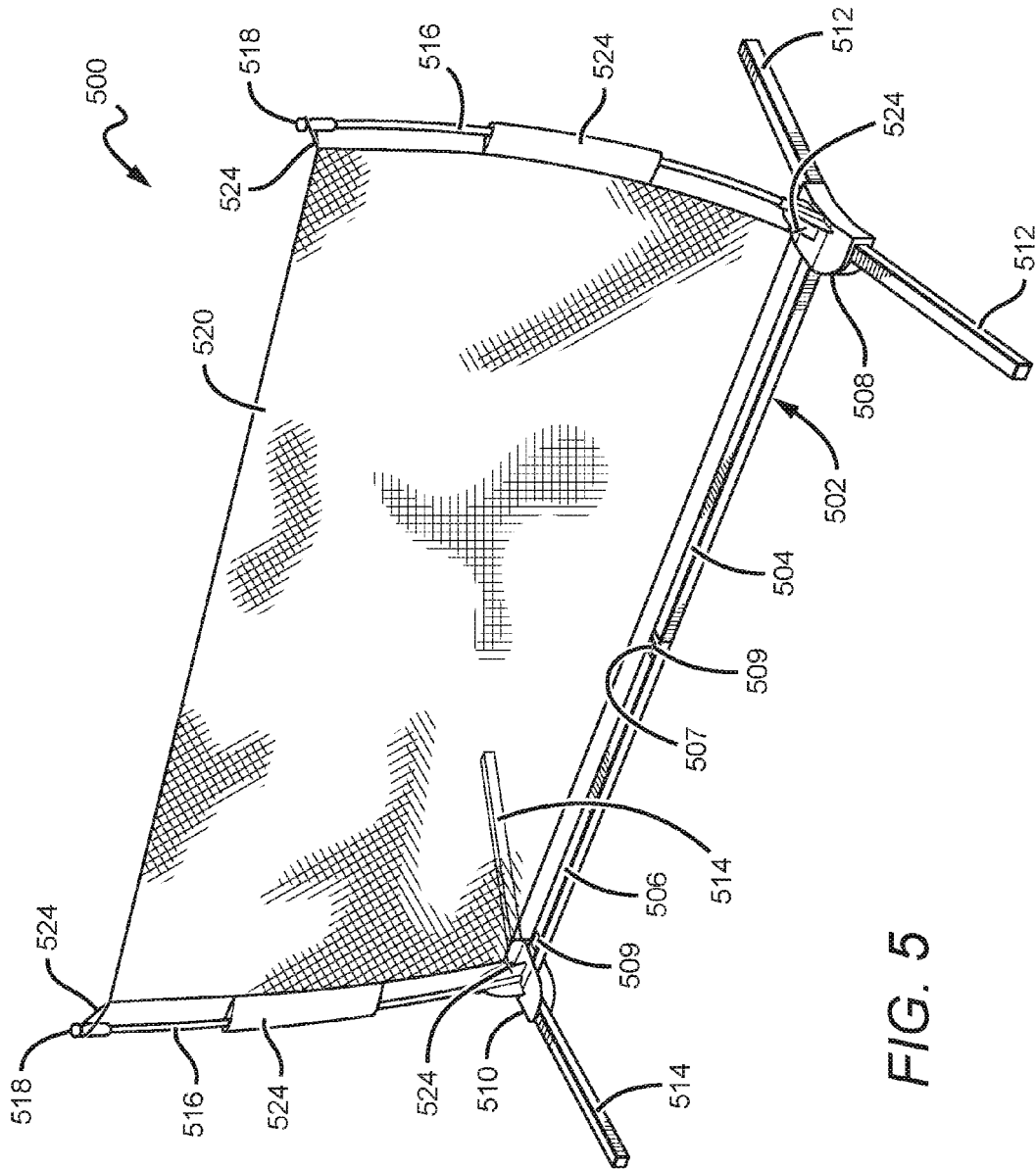

FIG. 5

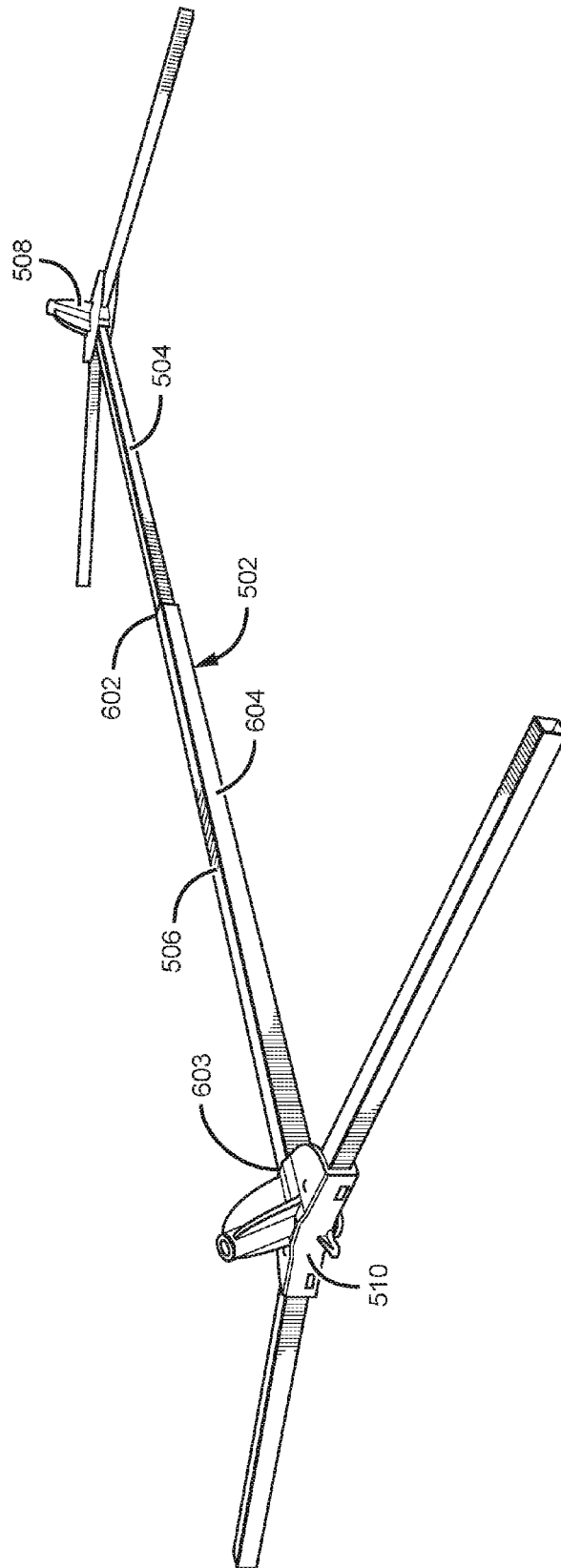

FIG. 6

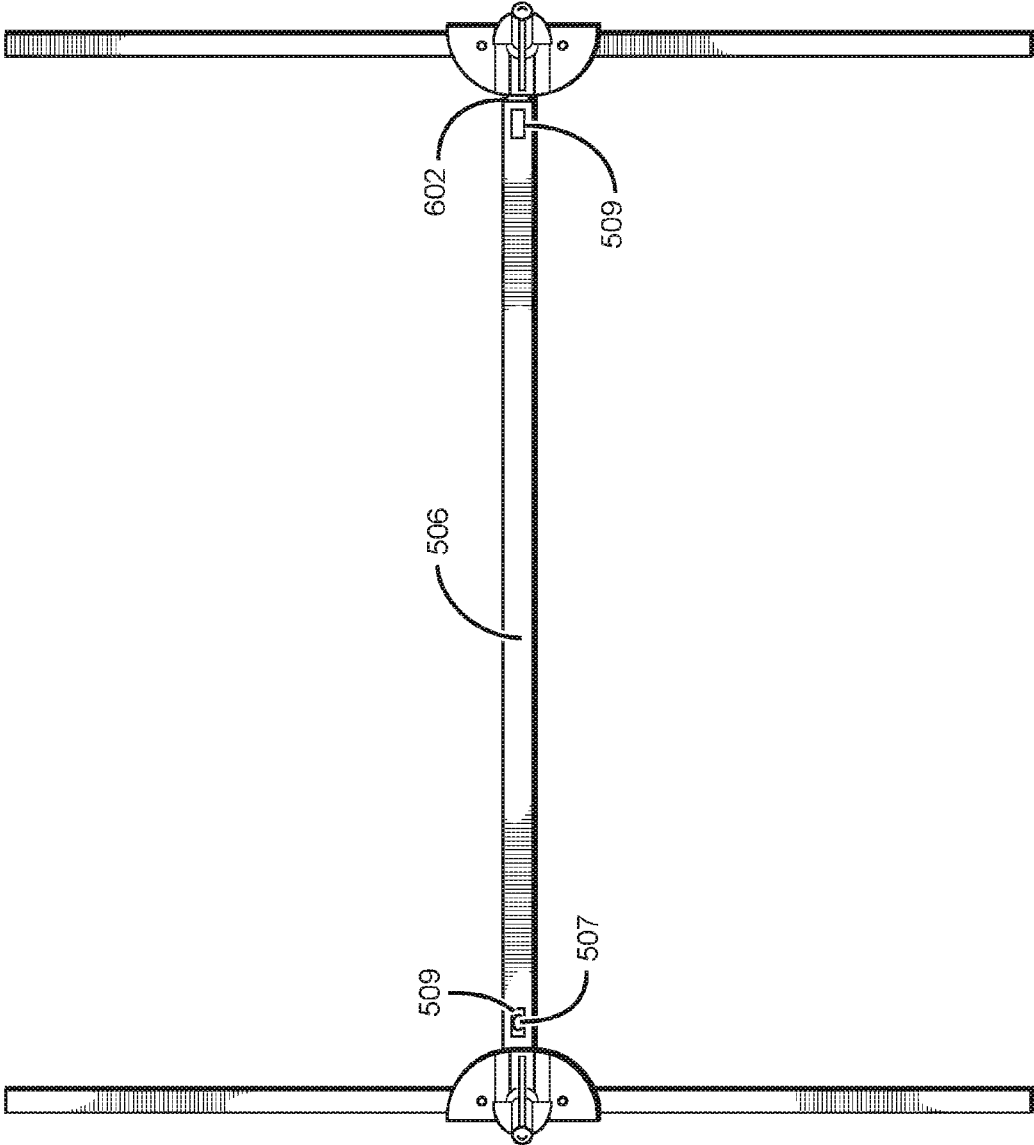
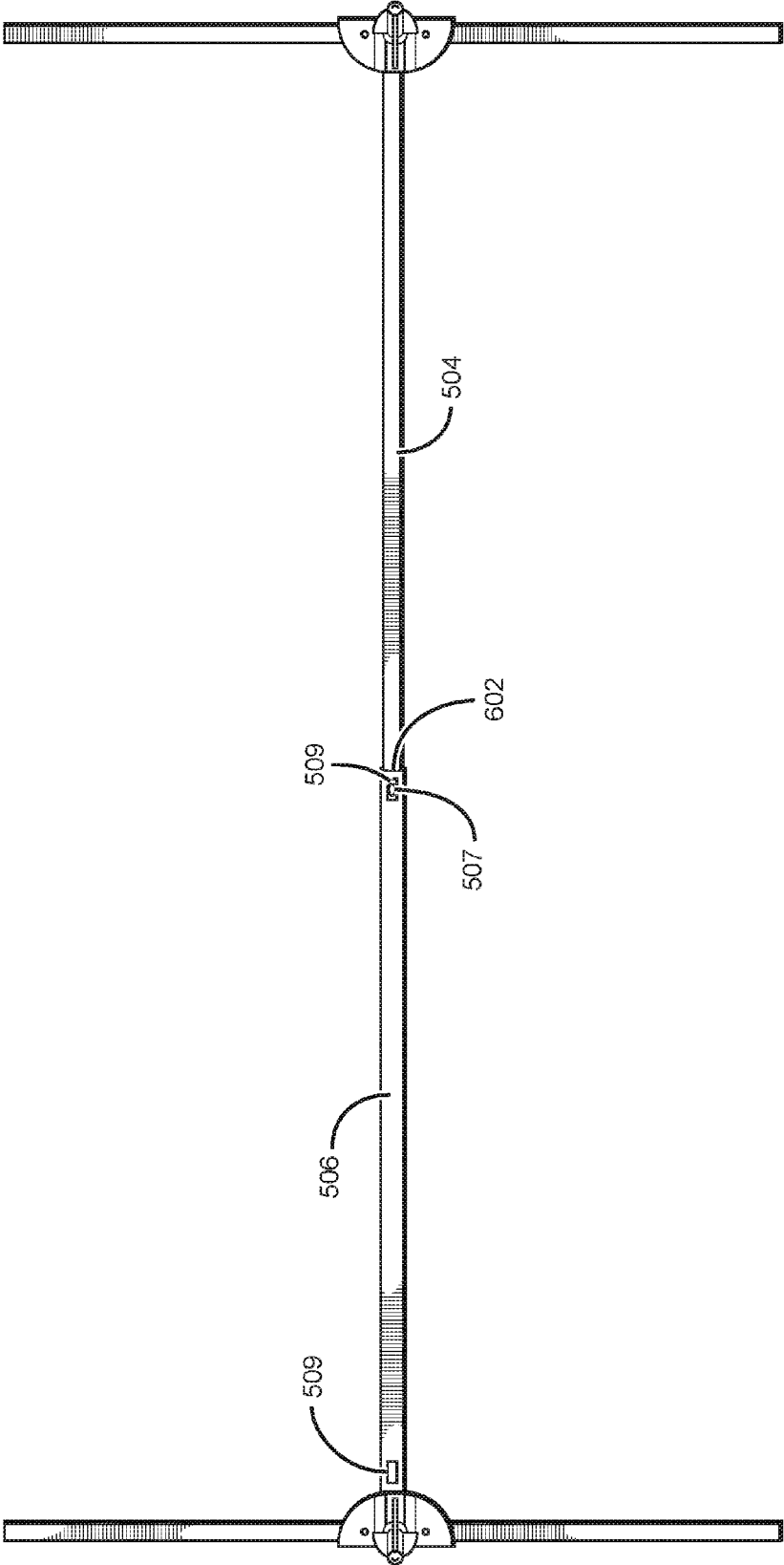

FIG. 7



FIG. 8



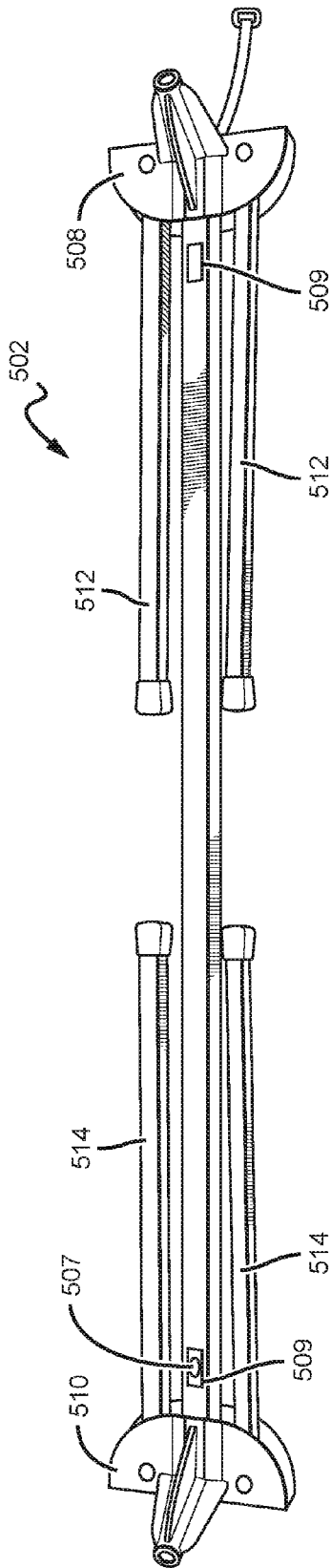

FIG. 9

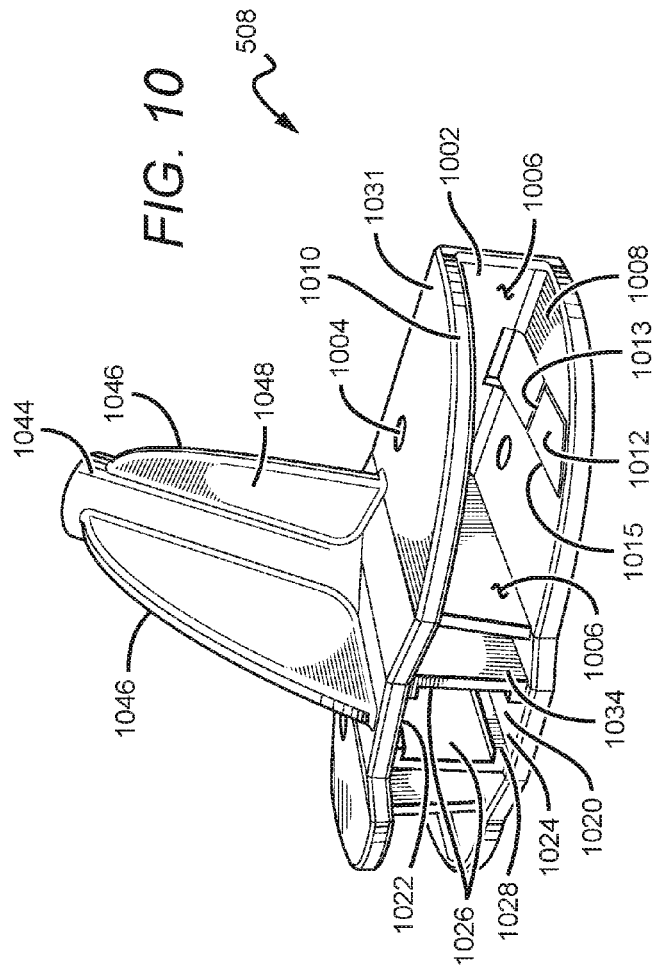
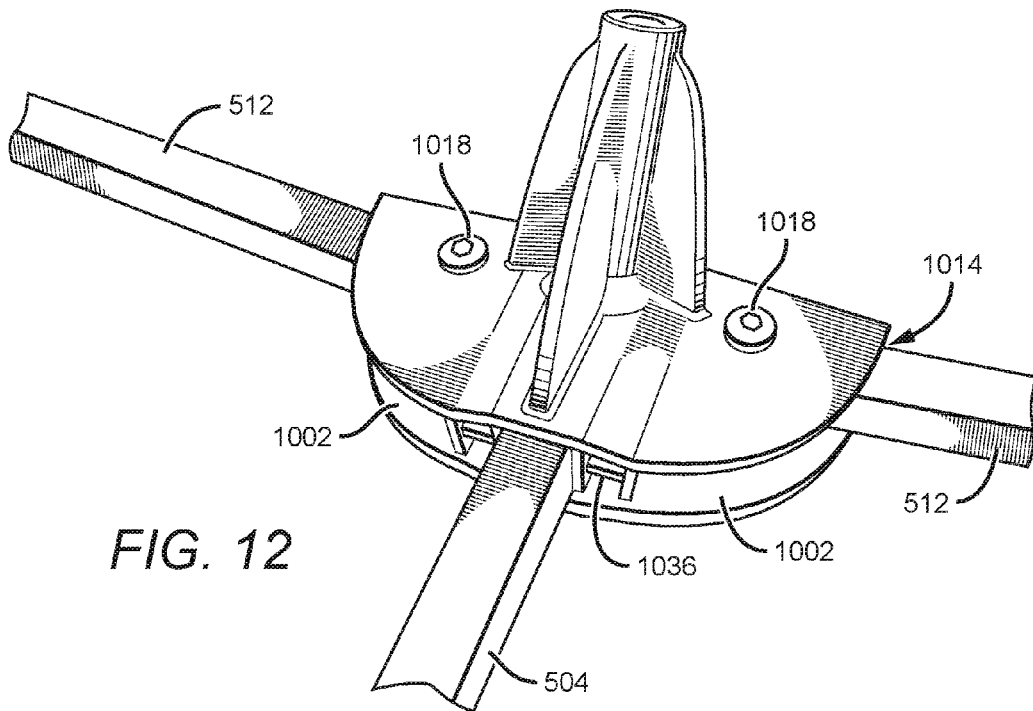
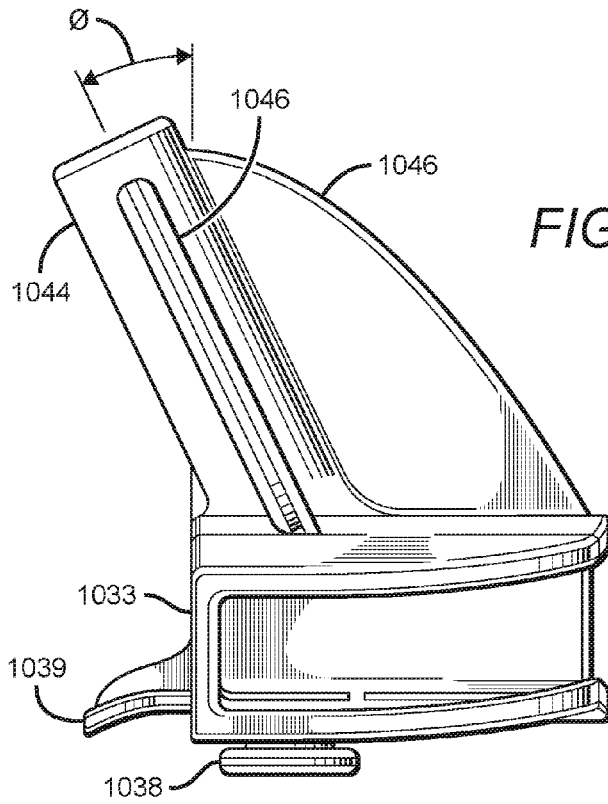

FIG. 10



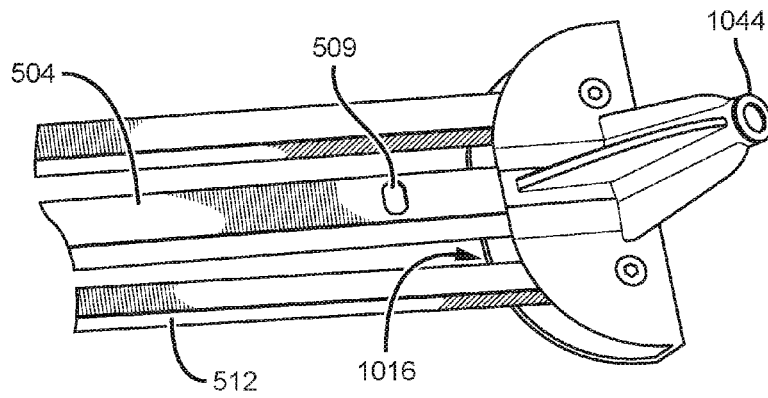

FIG. 13

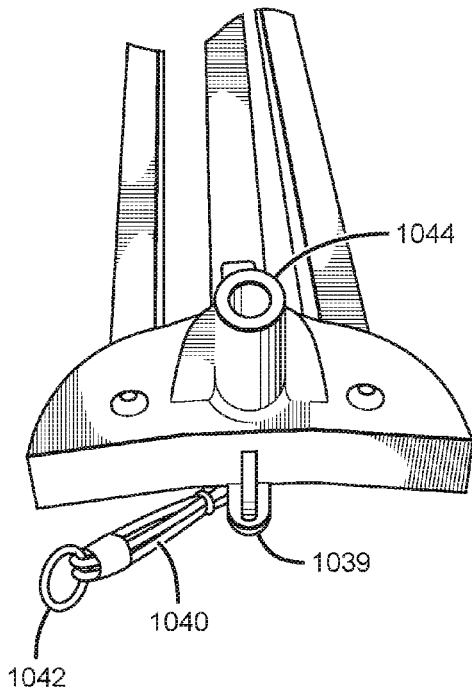

FIG. 14

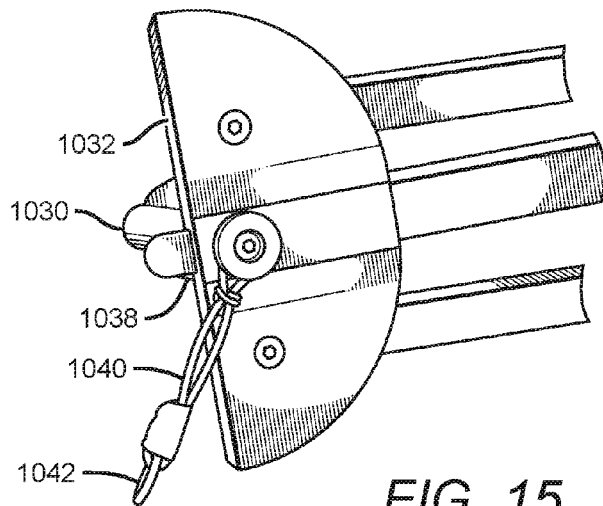

FIG. 15

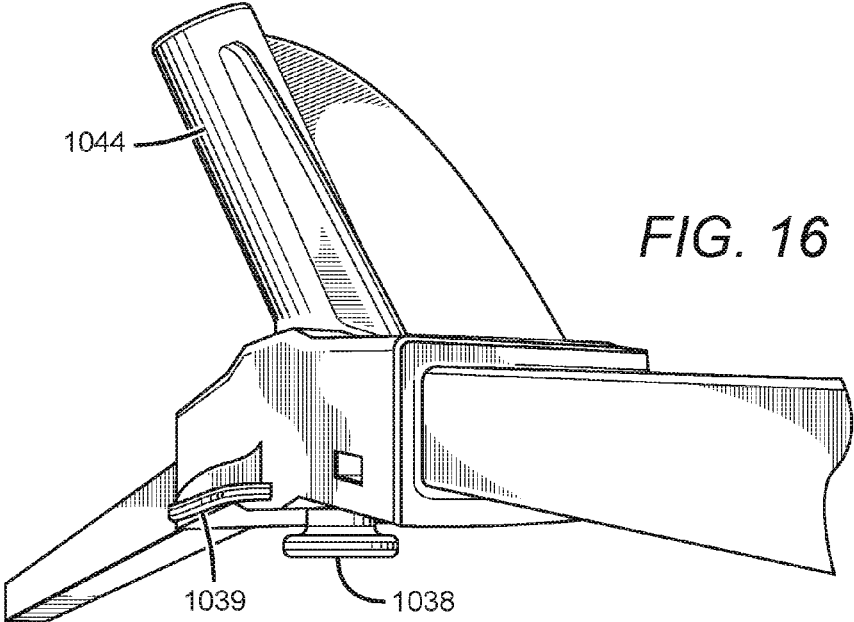
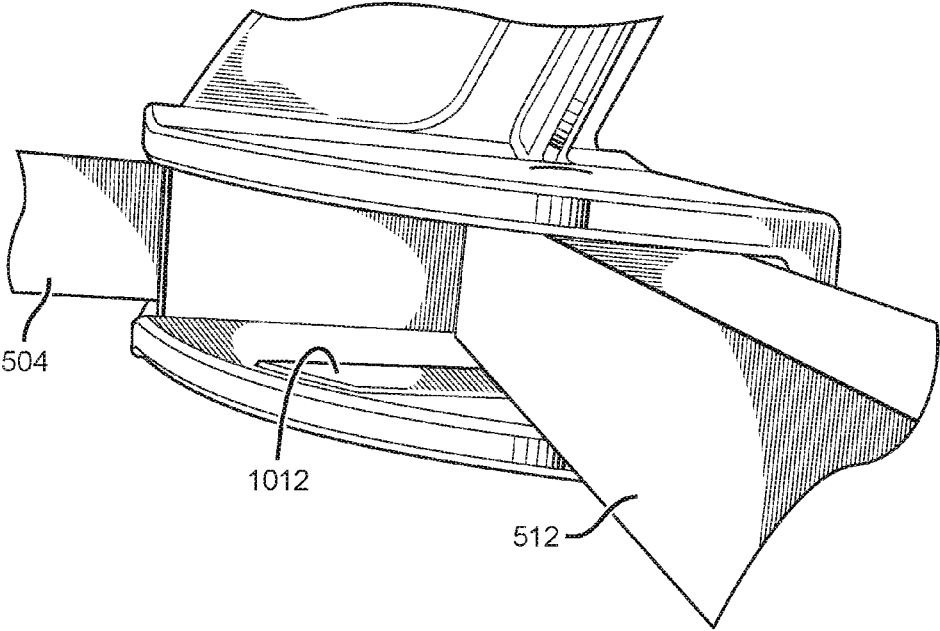

FIG. 16

FIG. 17



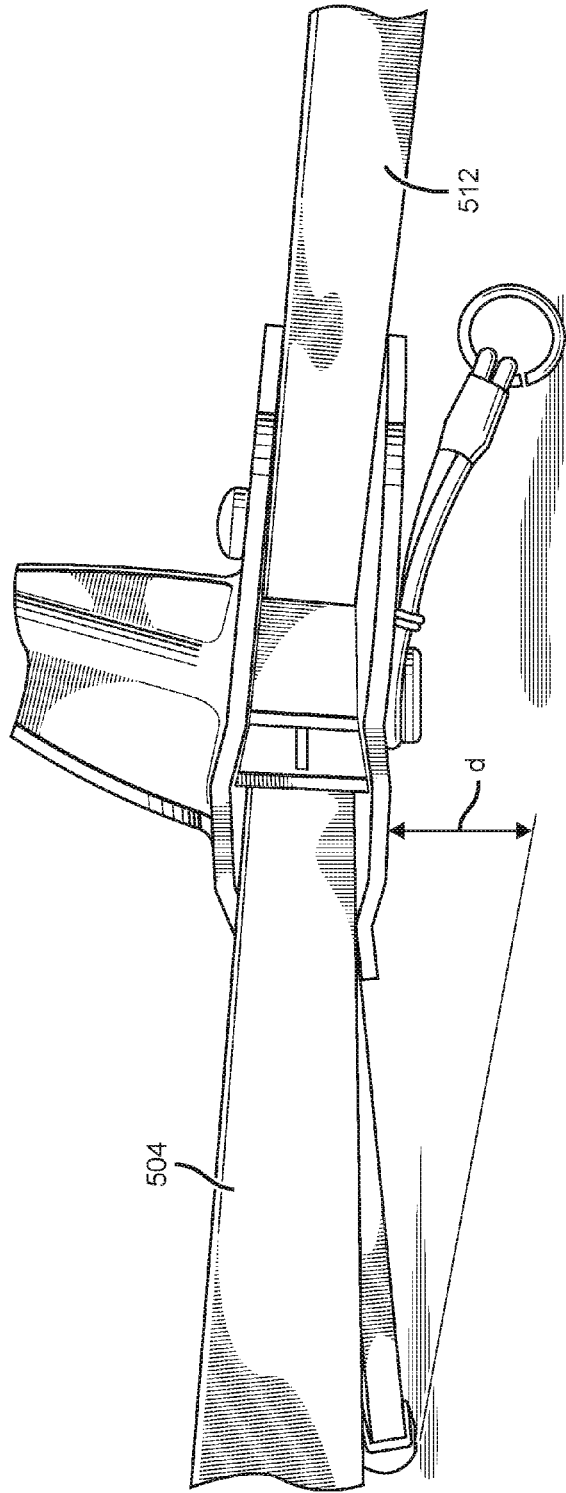

FIG. 18

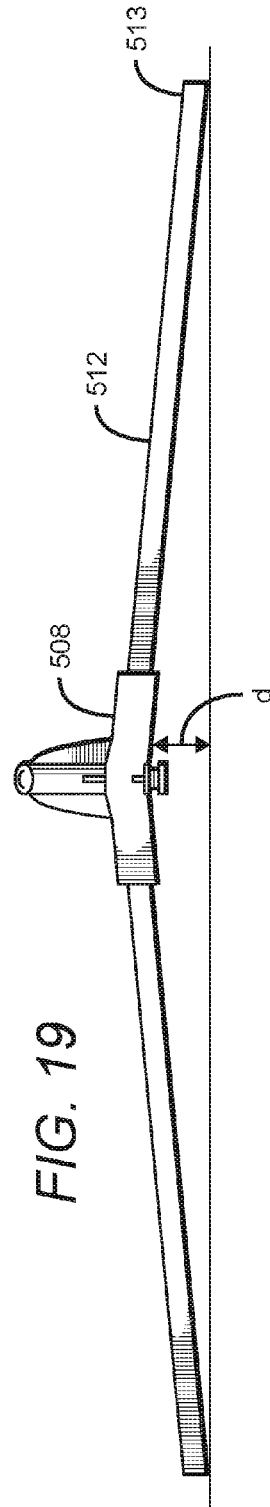

FIG. 19

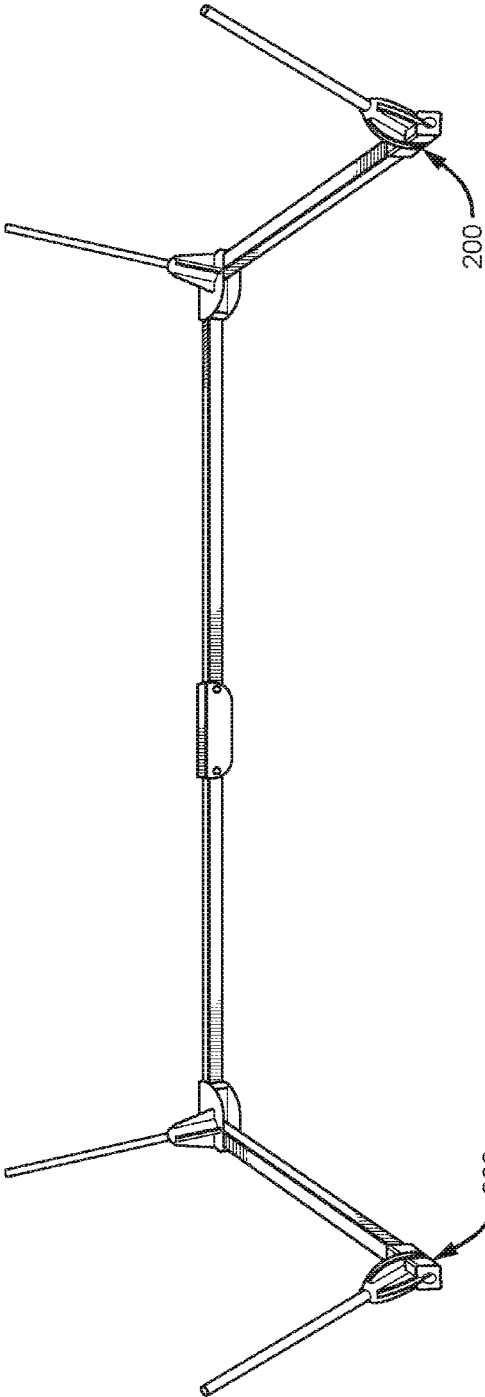

FIG. 20

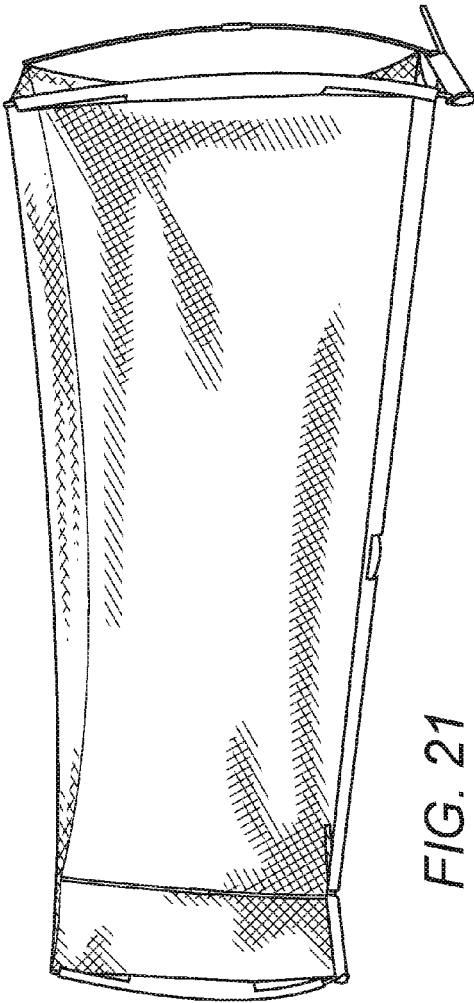

FIG. 21

1

**BALL NET STRUCTURE WITH ALTERABLE  
BASE**

## RELATED APPLICATION

This application is a continuation in part application of Ser. No. 15/068,354 to David Nelson et al., filed on Mar. 11, 2016, which is a continuation application of Ser. No. 13/485,775 to David Nelson et al., filed on May 31, 2012, now U.S. Pat. No. 9,283,455, which claims the benefit of priority of U.S. Provisional Application Ser. No. 61/492,010, filed on Jun. 1, 2011. This application also claims the benefit of priority of U.S. Provisional Application Ser. No. 62/287,356, filed on Jan. 26, 2016. The contents of Ser. Nos. 13/485,775, 15/068,354, 61/492,010, and 62/287,356, including their drawings, schematics, diagrams and written description, are hereby incorporated in their entirety by reference.

## BACKGROUND

## Field

This disclosure relates to a ball net structure adapted to be used in sports-related activities. More specifically, the disclosure is directed to a customizable ball net structure that is configured to be collapsible to allow for ease of portability and transport.

## Description of the Related Art

Various sports such as soccer or baseball involve hitting or throwing projectiles such as soccer balls or baseballs toward a desired direction in a field. For practice purposes, it is desirable to capture the ball before it travels a large distance or strikes objects or people. Existing capturing structures include a net attached to the perimeter of a capturing frame and a rigid support frame attached to the capturing frame. The support frame is attached to the capturing frame and provides a base allowing the capturing structure to be disposed on the ground.

A disadvantage of such structures is that they cannot be easily collapsed and efficiently stored. This is because both the support frame and the capturing frame must be properly folded and placed in a container. Further use of a capturing frame and a supporting frame makes such structures more expensive to manufacture and harder to carry due to increased weight.

There are portable ball net structures available, and they tend to have members that are formed from a single continuous piece or formed from numerous smaller pieces. A disadvantage of net structures formed of a single continuous piece is that they cannot be easily collapsed and efficiently stored due in part to its size. For example, a portable soccer goal can be formed of a single continuous frame wherein wheels are attached to a base to allow the soccer goal to be transported or wheeled out to a desired location. Although portable, transporting or positioning the soccer goal can be cumbersome, especially if the soccer goal is a regulation sized goal.

Portable goals formed of numerous pieces are more likely to be collapsible and easy transport, but have the distinct disadvantage of being difficult and slow to set up. For instance, loose fasteners may require tools for driving or tightening, and may also become lost in transit or storage or during assembly of the goal on the playing surface. Additionally, collapsible goals or nets may have components that are attached using lockable hinges. The hinges on such goals or nets typically require a locking device to hold the frame of the goal or net in a stable and locked position. Operation

2

of the locking device of a typical hinge normally requires a person to press a button or release/attach a clip to collapse or deploy the goal or net. Pressing the button or releasing/attaching the clip could cause injury to a person, even if performed with care. Furthermore, if such locking device were to malfunction or break, the hinge would be ineffective at holding the support frame of the goal; thereby rendering the goal inoperable.

The above frame structures are typically configured for a single configuration and net, such that the frame is fixed and cannot be configured into a different arrangement for a different net and/or a different sports-related activity. For example, the portable soccer goal formed of a single continuous frame cannot be modified into a differently configured frame for a different net because the single continuous frame is permanently fixed and only designed to be used with a soccer goal net. In addition, frames formed of multiple pieces can only be assembled in the designed single configuration and are not customizable.

The disclosure is a ball net structure that is portable, collapsible, modular, and able to be configured into different arrangements for different nets and/or different sports-related activities. For example, the ball net structure can be configured to receive nets of different sizes and/or configurations that are designed for different sports and/or different sports-related activities. The disclosure addresses these needs and provides further related advantages.

## SUMMARY

The disclosure provides various aspects of a ball net structure that is cost effective, easy to assemble/disassemble, easily transportable and provides the required structural support to receive and/or capture a projectile such as but not limited to a soccer ball or baseball. The ball net structure comprises elements to allow the ball net structure to be configured into different arrangements, such that the ball net structure can be used with different nets and/or attachments for different sports and/or different sports-related activities. The ball net structure is configured to be collapsible, easy to transport between locations and yet provide a sufficiently sized net to allow for sports practice or training, such as but not limited to soccer or baseball. The disclosure provides a ball net structure that can be easily assembled or disassembled by a single individual.

In one aspect of the disclosure, as broadly described herein, a ball net structure comprises a base structure including at least one support portion, at least one base extension, and a hinge, wherein the at least one support portion is coupled to the at least one base extension and the hinge. At least one rod is removably coupled to the base structure and received by a net, wherein the net is adapted to exert a pulling force on the at least one rod such that the at least one rod exerts a force onto said hinge in order to lock the at least one support portion in place.

In another aspect of the disclosure, the ball net structure comprises a base structure comprising first and second support portions pivotally attached to a hinge, a plurality of rods coupled to the base structure, and a net received by one or more of the plurality of rods, wherein the rods are configured to exert a force on the hinge in order to prevent rotation of the first and second support portions. The base structure, rods and net, when fully deployed, are adapted to withstand the force of a ball or projectile so as to capture the ball and to maintain the net apparatus in an upright position.

In another aspect of the disclosure, a ball net structure comprises a base structure comprising a first support por-



3

tion, a first base extension, and a first base extension hinge, wherein the first support portion and base extension are coupled to the first base extension hinge, a second support portion, a second base extension, and a second base extension hinge, wherein the second support portion and second base extension are coupled to the second base extension hinge. The first support portion is configured to receive the second support portion, wherein the second support portion comprises a locking pin that engages one of a plurality of openings in said first support portion to lock the first and second support portions together. The plurality of openings allows the positioning of second support portion within the first support portion to be adjustable. At least one rod is removably coupled to the base structure proximate at least one of the first and second base extension hinges, and is received by a net. The net is adapted to exert a pulling force on the at least one rod such that the at least one rod is in a flexed state. The adjustability of the second support portion within the first support portion allows the base structure to be arranged to be configured into different arrangements, such that the ball net structure can be used with different nets and/or attachments for different sports and/or different sports-related activities.

In another aspect of the disclosure, the ball net structure comprises a base structure comprising at least one support portion, at least one base extension, at least one base extension hinge, and a base hinge, wherein the at least one support portion is coupled to the at least one base extension hinge and the base hinge, and the at least one base extension is coupled to the at least one base extension hinge. At least one rod is removably coupled to the base structure and received by a net, wherein the net is adapted to exert a pulling force on the at least one rod such that the at least one rod exerts a torque force onto said base hinge in order to lock the at least one support portion in place.

This has outlined, rather broadly, the features and technical advantages of the disclosure in order that the detailed description that follows may be better understood. Additional features and advantages of the disclosure will be described below. It should be appreciated by those skilled in the art that this disclosure may be readily utilized as a basis for modifying or designing other structures for carrying out the same purposes of the present disclosure. It should also be realized by those skilled in the art that such equivalent constructions do not depart from the teachings of the disclosure as set forth in the appended claims. The novel features, which are believed to be characteristic of the disclosure, both as to its organization and method of operation, together with further objects and advantages, will be better understood from the following description when considered in connection with the accompanying figures. It is to be expressly understood, however, that each of the figures is provided for the purpose of illustration and description only and is not intended as a definition of the limits of the present disclosure.

#### BRIEF DESCRIPTION OF THE DRAWINGS

FIG. 1 is a perspective view of a ball net structure according to an aspect of the disclosure.

FIG. 2a is a side view of a hinge according to an aspect of the disclosure.

FIG. 2b is another side view of the hinge according to an aspect of the disclosure.

FIG. 2c is another side view of the hinge according to an aspect of the disclosure.

4

FIG. 3 is a perspective view of a base structure according to an aspect of the disclosure.

FIG. 4 is a perspective view of a ball net structure according to an aspect of the disclosure.

FIG. 5 is a perspective view of a ball net structure according to an aspect of the disclosure.

FIG. 6 is a perspective view of a base structure according to an aspect of the disclosure.

FIG. 7 is a top plan view of the base structure of FIG. 6. FIG. 8 is another top plan view of the base structure of FIG. 6.

FIG. 9 is another top plan view of the base structure of FIG. 6.

FIG. 10 is a perspective view of a base extension hinge according to an aspect of the disclosure.

FIG. 11 is a side view of the base extension hinge of FIG. 10.

FIG. 12 is a perspective view of a base structure according to an aspect of the disclosure.

FIG. 13 is a perspective view of a base structure according to an aspect of the disclosure.

FIG. 14 is a side view of a base structure according to an aspect of the disclosure.

FIG. 15 is a bottom view of a base structure according to an aspect of the disclosure.

FIG. 16 is a side view of a base structure according to an aspect of the disclosure.

FIG. 17 is an enlarged side view of a base extension hinge according to an aspect of the disclosure.

FIG. 18 is a side view of a base structure according to an aspect of the disclosure.

FIG. 19 is a side view of a base structure according to an aspect of the disclosure.

FIG. 20 is a perspective view of a base structure according to an aspect of the disclosure.

FIG. 21 is a perspective view of a ball net structure according to an aspect of the disclosure.

#### DETAILED DESCRIPTION

The disclosure described herein is directed to different aspects of a ball net structure that in some aspects provide a frame structure that is easy to setup and is collapsible such that the frame structure is easy to assemble by a single individual, store, is portable, and is customizable for different nets and/or sports-related activities. The detailed description set forth below, in connection with the appended drawings, is intended as a description of various configurations and is not intended to represent the only configurations in which the concepts described herein may be practiced. The detailed description includes specific details for the purpose of providing a thorough understanding of the various concepts. It will be apparent, however, to those skilled in the art that these concepts may be practiced without these specific details. In some instances, well-known structures and components are shown in block diagram form in order to avoid obscuring such concepts. As described herein, the use of the term "and/or" is intended to represent an "inclusive OR", and the use of the term "or" is intended to represent an "exclusive OR".

The ball net structure can comprise many different materials and can be used in many different applications such as, but not limited to, practicing soccer skills, throwing and/or hitting baseballs. The ball net structure according to the disclosure can be arranged in many different ways with many different components, and is generally arranged to provide a net structure to capture or catch a projectile. In one

5

aspect, as broadly described herein, a ball net structure comprises a base structure comprising at least one support portion and at least one base extension. The ball net structure further comprises a hinge, wherein the at least one support portion is coupled to the at least one base extension and the hinge. At least one rod is removably coupled to the base structure and is adapted to be received by a net. The net is adapted to exert a pulling force on the at least one rod causing the at least one rod to exert a torque force onto said hinge, whereby the at least one support portion is locked into place. In other aspects of the disclosure, the ball net structure comprises a base structure comprising a first support portion and a second support portion, wherein the first and second support portions are attached to a hinge, such that the first and second support portions are opposite each other and the hinge is interposed therebetween. At least one rod is removably received by the base structure, wherein a net is adapted to receive the at least one rod. The ball net structure further comprises a first base extension coupled to the first support portion and a second base extension coupled to the second support portion. The first and second base extensions are adapted to further support the load of the ball net structure and allow the ball net structure to remain upright while in use. In some aspects, the ball net structure can also comprise an attachment device proximate the base structure, such that the attachment device is adapted to receive an attachment cord that is adapted to receive a weighted device or force resistance device to provide additional structural support. The attachment device can also be configured to receive part of the net. In some aspects, the attachment device can be on at least one base extension, at least one support portion, the hinge, or a combination thereof. At least one advantage of the ball net structure is that the ball net structure is configured to exert a force on the hinge so as to maintain the ball net structure in an upright state when deployed. This arrangement allows the hinge to remain in a fixed state without the need of one or more locking devices to lock the support portion to the hinge.

In another aspect, the ball net structure comprises a base structure comprising a first support portion, a first base extension, and a first base extension hinge, wherein the first support portion and first base extension are coupled to the first base extension hinge. The base structure can comprise a second support portion, a second base extension, and a second base extension hinge, wherein the second support portion and second base extension are coupled to the second base extension hinge. The first support portion is configured to receive the second support portion, wherein the second support portion comprises a locking pin that engages one of a plurality of openings in said first support portion to lock the first and second support portions together. At least one rod is removably coupled to the base structure and is received by a net. The net is adapted to exert a pulling force on the at least one rod such that the at least one rod is bent in a flexed state. The first and second base extensions are adapted to support the load of the ball net structure and allow the ball net structure to remain upright while in use. In some aspects, the ball net structure can also comprise at least one attachment device on the base structure, such that the at least one attachment device is adapted to receive an attachment clip which is adapted to provide additional structural support. The at least one attachment device can also be configured to receive part of the net. In some aspects, the at least one attachment device can be on at least one support portion, at least one base extension, at least one base extension hinge, or a combination thereof.

6

The ball net structure of the disclosure can provide a number of additional advantages beyond those mentioned above. For example, the hinge allows for ease of assembly/disassembly and storage of the ball net structure because the hinge does not have a locking device that needs to be forcibly engaged and/or disengaged. Typical hinges have a locking pin that prevents an element from pivoting about a hinge. These locking pins can be hard to engage and/or disengage which could cause injury to the person trying to engage and/or disengage the locking pin. Other typical hinges have a locking button, instead of a locking pin, that is depressed in order to allow an element to be engaged and/or disengaged from the hinge. In such hinges, operation of the locking button requires the person to press down and pivot the element about the hinge. In some instances, the person pressing the locking button could get a portion of their finger caught and/or pinched by the button causing injury. In addition, these push locking buttons may not withstand forces imparted by a ball/projectile and/or forces from users, such as kicks, that occur during normal use. Another advantage of the disclosure is that the ball net structure is collapsible such that the ball net structure can be folded upon itself and form a smaller package that can easily be transported and/or stored without taking up too much physical space. A disadvantage of hinges having the locking pin or the locking button is that the locking pin or the locking button will deteriorate over time due to many different factors, such as the load imparted onto them or by damage due to repeated use or misuse. At least another advantage of the disclosure is that the first support portion being configured to receive the second support portion allows the base structure to alter its shape and/or size such that nets of different sizes can be used with the ball net structure. Additionally, nets of different sizes and/or configurations can be used with the ball net structure, due in part to the adjustability of the base structure. The ability to use nets that are differently sized and/or differently configured with the ball net structure allows various training exercises and/or sports-related activities to be performed with the ball net structure.

The ball net structure of the disclosure can be used to stop or capture a ball or the like when performing sports-related activities. However, the disclosure is not intended to be limited to such aspects. As further described below, the ball net structure can be arranged to allow an individual to easily deploy and disassemble the ball net structure in an outdoor or indoor setting.

The disclosure is described herein with reference to certain aspects, but it is understood that the disclosure can be embodied in many different forms and should not be construed as limited to the aspects set forth herein. In particular, the disclosure is described below in regards to a ball net structure to practice or perform sports-related activities in an outdoor setting, but it is understood that the disclosure can be used for many other applications in many different settings. The components of the ball net structure can have different shapes and sizes beyond those shown in the figures or discussed herein.

Although the terms first, second, etc. may be used herein to describe various elements or components, these elements or components should not be limited by these terms. These terms are only used to distinguish one element or component from another. Thus, a first element discussed herein could be termed a second element without departing from the teachings of the present application. It is understood that actual systems or fixtures embodying the disclosure can be

arranged in many different ways with many more features and elements beyond what is shown in the figures.

It is to be understood that when an element or component is referred to as being “on” another element or component, it can be directly on the other element or intervening elements may also be present. Furthermore, relative terms such as “between”, “within”, “below”, and similar terms, may be used herein to describe a relationship of one element or component to another. It is understood that these terms are intended to encompass different orientations of the device in addition to the orientation depicted in the figures.

Aspects of the disclosure are described herein with reference to illustrations that are schematic illustrations. As such, the actual thickness of elements can be different, and variations from the shapes of the illustrations as a result, for example, of manufacturing techniques and/or tolerances are expected. Thus, the elements illustrated in the figures are schematic in nature and their shapes are not intended to illustrate the precise shape of a region of a device and are not intended to limit the scope of the disclosure.

FIGS. 1-2c show one aspect of a ball net structure 10 according to an aspect of the disclosure. In some aspects, the ball net structure 10 is configured such that the ball net structure 10 can be deployed in an outdoor setting such as, but not limited to, a natural grass, synthetic field, dirt, concrete or the like. In other aspects, the ball net structure 10 can be deployed in an indoor setting such as but not limited to an indoor training facility, residential or commercial setting having a synthetic or natural surface, or the like. The ball net structure 10 can be used in sports-related activities, such as but not limited to baseball, softball, soccer, football and the like. The ball net structure 10 can also be used to allow users to practice kicking, hitting or throwing a ball or other projectile to the ball net structure 10, such that the ball net structure captures or catches the ball so that the user does not have to travel great distances to retrieve the ball. The ball net structure 10 comprises a base structure 12 comprising first and second support portions 14, 16 pivotally attached to a hinge 22, a plurality of rods 26 removably coupled to the base structure 12, and a net 30 adapted to receive the plurality of rods 26. The aspect shown in FIG. 1 has two rods 26, but other aspects can have more than two rods 26. The rods 26 are configured to exert a force on the hinge 22 in order to lock the first and second support portions 14, 16 in place and prevent rotation of the first and second portions 14, 16 about the hinge 22. The base structure 12, rods 26 and net 30, when fully assembled and deployed, are adapted to withstand the force of a ball or projectile so as to capture the ball while keeping the ball net structure 10 in an upright position.

For the same or similar elements or features, the reference numbers from FIGS. 1-2c may be used throughout the application herein. In one aspect of the disclosure, the base structure 12 can comprise a first base extension 18 coupled to the first support portion 14 and a second base extension 20 coupled to the second support portion 16. This arrangement allows the first and second base extensions 18, 20 to provide additional structural support to further stabilize the ball net structure 10 in an upright position. In some aspects, the first and second base extensions 18, 20 can be coupled to the respective support portions 14, 16 such that the first and second base extensions 18, 20 are perpendicular to the respective support portion 14, 16. In other aspects, the first and second base extensions 18, 20 can be angled in a V-shaped configuration and configured to raise the base structure 12 above the ground or surface or allow the base structure 12 to contact the ground or surface, wherein the

angle of the V-shaped base extensions 18, 20 can be in the range of 90°-140° (degrees). In yet other aspects, as in FIG. 3, a base extension 55 comprises a base extension hinge 50 coupled to the support portions 16 and 14 (not shown), first and second base extension legs 52, 54 pivotally attached to the base extension hinge 50 about a respective pivot point 51, and can be locked into place by respective locking pins/buttons 53. In this arrangement, the legs 52, 54 can be released from their respective locking pins/buttons 53 and are able to rotate about pivot points 51 towards the support portions 16 and 14 such that the base structure 56 is further collapsible and easy to transport. In the aspect of FIG. 1, the base extensions 18, 20 are stationary and are not able to be rotated towards their respective support portion 14, 16. Additionally, the first and second legs 52, 54, in FIG. 3 can be arranged either bent, curved, or straight, such that the base structure 56 is elevated off the ground or surface. However, in other aspects, the legs 52, 54 can be arranged to allow the base structure 56 to contact the ground or surface. The legs 52, 54 can also comprise the attachment device 33, attachment cord 32 and ring 34 as discussed in the aspect of FIG. 1.

The first and second support portions 14, 16 each have a first end 15 and a second end 17, wherein the first end 15 of each of the support portions 14, 16 is coupled to the respective base extensions 18, 20. The first and second support portions 14, 16 extend from the respective base extensions 18, 20 towards a hinge 22 and are pivotally coupled to the hinge 22, such that the base extensions 18, 20 are opposite the hinge 22. The second ends 17 of support portions 14, 16 are coupled to the hinge 22 using hinge pins 24. The hinge 22 has openings 25 that receive the hinge pins 24 so as to couple the support portions 14, 16 to the hinge 22. In one aspect, the hinge pins 24 can be screws with a nut to hold the screw in place. However, in other aspects, the openings 25 of the hinge 22 can be threaded to receive the hinge pins 24, or the hinge pins can be nails, rivets or the like. The support portions 14, 16 can be coupled to the hinge 22 using various known means in the art and is not intended to be limited to the aspects disclosed herein. The first and second support portions 14, 16 can be made of many different materials known in the art, such as but not limited to wood, plastic, metal, a composition thereof or the like. The first and second support portions 14, 16 can be formed to have many different shapes, such as but not limited to circular, square, polygonal, a combination thereof or the like. The first and second portions 14, 16 of the aspect of FIGS. 1-2c are shown as having a square-like shape.

The hinge 22 is arranged to receive at least a portion of the first and second support portions 14, 16 such that the support portions 14, 16 are able to rotate about the respective hinge pin 24. In one aspect, the hinge 22 is configured to be a U-shaped channel having a hinge base 27, sidewalls 29 and openings 25 to allow respective hinge pins 24 to be received by the hinge 22 as well as the first and second support portions 14, 16, such that the first and second support portions 14, 16 are pivotally coupled to hinge 22. In the aspect of FIG. 1, the second ends 17 of each of the first and second support portions 14, 16 are pivotally coupled to the hinge 22. However, in other aspects, the first and second support portions 14, 16 can be pivotally coupled to the hinge 22 at different locations between the first and second ends 15, 17.

An advantage of the disclosure is that in some aspects the hinge 22 can be U-shaped which allows the hinge 22 to hold the first and second support portions 14, 16 in a stable and parallel position along the same axis and also provides a

physical stop which prevents the first and second support portions 14, 16 from pivoting beyond the physical stop. However, in other aspects, the hinge 22 can be shaped in different forms such that the support portions 14, 16 are not aligned along the same axis, can be parallel or non-parallel, yet still provide a physical stop to prevent the portions 14, 16 from rotating beyond the physical stop.

As shown in FIGS. 1-2c, the first and second portions 14, 16 are coupled to the hinge 22, using hinge pins 24, such that they rotate about the respective hinge pin 24. Rotation of the first support portion 14, in a direction opposite the second support portion 16, about the hinge pin 24 will stop when the first support portion 14 comes into contact with the hinge base of the hinge 22; FIG. 2c shows an example of the support portions 14, 16 in contact with the hinge base 27 and precluding further rotation. The hinge base 27 provides a physical stop and prevents the first support portion 14 from further rotation. The second support portion 16 is similarly configured as the first support portion 14 and will stop rotating about hinge pin 24 when the second support portion 16 contacts the hinge base 27. The physical stop provided by the hinge 22 properly aligns the first and second support portions 14, 16 when assembling the ball net structure 10. Yet another advantage of the disclosure is that the hinge 22 allows the base structure 12 to be folded onto itself so that the ball net structure 10 can be easily stored as well as easy to transport. This arrangement allows the base structure 12 to reduce its size and/or area, thereby allowing the ball net structure 10 to be stored in a small container.

When assembling the ball net structure 10, the first and second support portions 14, 16 of the base structure 12 are rotated away from the opposite support portion 16, 14 towards the hinge base 27. When the support portions 14, 16 are in contact with the hinge base 27, precluding further rotation, the base structure 12 is ready to be placed on the playing surface, such as but not limited to a natural grass, synthetic field, cement, wood, asphalt, or the like. The base structure 12 is placed on the playing surface such that the hinge base 27 is opposite the playing surface. In other words, the hinge base 27 does not contact the surface upon which the base structure 12 is positioned on. The hinge 22 can be arranged in many different configurations and is not intended to be limited to the aspects presented herein. In some aspects, the hinge 22 can be configured such that the hinge base 27 is proximate the playing surface. At this point, the at least one rod 26 is ready to be installed.

The base structure 12 is further adapted to receive the at least one rod 26. In one aspect, the base structure 12 comprises at least one shaft 31 extending substantially vertically and configured to receive one of the at least one rod 26. In another aspect, the base structure 12 comprises a plurality of shafts 31, wherein each respective shaft 31 is adapted to receive a respective one of the at least one rod 26. In the aspect of FIG. 1, the base structure 12 comprises two shafts 31, with one shaft 31 coupled to the first base extension 18 and another shaft 31 coupled to the second base extension 20. As shown in FIG. 1, each of the shafts 31 are coupled to a respective base extension 18, 20 proximate the first end 15 of the first and second support portions 14, 16. However, in other aspects, the shaft 31 can be positioned at various other locations on the base extensions 18, 20 and/or the support portions 14, 16, or a combination thereof. In yet other aspects, the base structure 12 can comprise more than two shafts 31 for aspects that comprise more than two rods 26. The number of shafts 31 present will be equal to the number of rods 26.

The at least one rods 26 are configured to be securely held within the shaft 31, such that the shaft 31 maintains a stable structural connection between the shaft 31 and the at least one rods 26 and prevents the rod 26 from being removed from the shaft 31 when the ball net structure 10 is assembled. In one aspect of the disclosure, the shaft 31 is similarly shaped as the rod 26, such as but not limited to cylindrically shaped, and is slightly larger than the rod 26 such that the rod 26 can easily be received by the shaft 31. The shaft 31 can further comprise a sheath contacting the inner wall of the shaft 31 that receives the rod 26. The sheath is adapted to protect the rod 26 within the shaft 31 from forces exerted on the rod 26 when the ball net structure 10 is fully assembled. As will be discussed below, upon assembly of the ball net structure 10, the rods 26 experience a moment force at the point where the rod 26 is received by the shaft 31, and causes the rod 26 to exert a compression force upon the sheath. The sheath thereby protects the rod 26 from the forces exerted on and/or by the rod 26.

In other aspects, the shaft 31 can be shaped such that the radius of the shaft 31 decreases the further the rod 26 is inserted into the shaft 31. In this arrangement, the shaft 31 uses a compression force to form the structural connection between the shaft 31 and the rod 26. In other aspects, mechanical devices, such as but not limited to, screws, nuts, nails, rivets or the like, can be used to form the structural connection so as to securely attach the rod 26 to the shaft 31. In yet other aspects, the rods 26 can be configured to have an attachment means such that the rods 26 can be attached to the shaft 31; non-limiting examples of such attachment means are the rods 26 being threaded and screwed into the shaft 31 or the rod 26 and shaft 31 configured similarly like a bayonet-type locking device.

In the aspect of FIG. 1, the rods 26 are circularly shaped and the shaft 31 is also correspondingly circularly shaped to receive the rod 26. The shape of the rod 26 and shaft is not intended to be limited to a circular shape, other shapes such as quadrilateral, triangular, or any other polygonal shape can be used. The shaft 31 can also be similarly shaped as the rod 26, but in some aspects, the shaft 31 can be shaped differently than the rod 26. The rods 26 can be made of many different materials known in the art, such as but not limited to fiberglass or carbon fiber, such that the rods 26 are flexible, elastic, capable of returning to an initial form or state after deformation, and able to withstand the impact forces applied by sports-related balls and/or other projectiles that can be captured or caught by the ball net structure 10, or thrown, kicked, and/or hit towards the ball net structure 10.

The rods 26, when received by the shaft 31 flare outwards, such that the rods 26 are in a relaxed state and are substantially straight. A net 30 comprising at least one sleeve 33 is arranged to receive the at least one rod 26 and is adapted to exert a force on the at least one rod 26 bending the at least one rod 26 into a flexed state. Inserting the at least one rod 26 into the sleeve 33 results in the at least one rod 26 being bent from the relaxed state into a flexed state. As shown in FIG. 1, when both rods 26 are received by the respective shaft and the net 30, both rods 26 are bent inwards towards the opposing rod and into the flexed state. Removal of the net 30 allows the rods 26 to return to their original form of the relaxed state. Repeated use of the ball net structure 10 does not result in the rods 26 being permanently bent in a shape similar to that of the flexed state. The net 30 can be easily installed and removed by a single individual.

The net 30 imparts a pulling force on each of the rods which causes each of the rods 26 to bend in a direction

11

towards the hinge 22. Once bent towards the hinge 22, the rods 26 are in the flexed state and experience a moment force about its pivot point. The pivot point of each of the rods 26 corresponds to the point at which the rods 26 are received by the shaft 31. The moment force experienced by the rods 26 is imparted onto the hinge 22 and the first and second support portions 14, 16 of the base structure 12, with the transferred force being greatest at the hinge 22. This transferred force further assists in locking the hinge 22 and base structure 12, such that the first and second support portions 14, 16 are locked into place.

An advantage of the disclosure is that the force exerted onto the rods 26 by the net 30 results in a torque force experienced by the rods 26 and transferred to the hinge 22, which allows the hinge 22 to lock the first and second support portions 14, 16 into place without the need of a locking device such as a locking clip or button. The absence of such a locking device on the hinge 22 prolongs the lifetime of the ball net structure 10 due, in part, to the hinge 22 not deteriorating or breaking down due to failure or malfunctioning of the locking clip or button.

The net 30 can be a mesh surface or any typical net known in the art. The net comprises at least one sleeve 33 adapted to receive the rod 26 so as to mount the net 30 onto the rods 26. The aspect of FIG. 1 shows the net 30 having a sleeve 33 in the form of a plurality of loops that receive the rods 26. However, in other aspects, such as FIG. 4, the net 30 comprises a plurality of sleeves 33 wherein at least one of the plurality of sleeves 33 receives the base structure 12, in order to provide additional structural support for the ball net structure 10. The sleeve 33 can be configured in many different ways, such as but not limited to a sleeve that spans the length of the rod, a plurality of smaller sleeves that are spaced apart from each other and run along the length of the rods 26, or a sleeve that spans along a partial length of the rods 26. In some aspects, each rod 26 comprises an endcap 28 opposite the portion of the rod 26 that is received by the shaft 31 and is configured to receive at least a portion of the sleeve 33, such that the endcap 28 prevents the sleeve 33 from coming off the rods 26 while the ball net structure 10 is assembled and/or in use. In one aspect, the endcaps 28 can have a tab that extends outward beyond the external shape of the rod 26 that prevents the net 30 from coming off the rod 26. However, in other aspects, the endcaps 28 can have other means of preventing the net 30 from coming off the rod 26, such as but not limited to a hook, loop, locking clip, or the like.

The ball net structure 10 according to the disclosure is designed to withstand the force of a ball or other projectile so as to catch or capture the ball, such that the ball net structure 10 maintains an upright standing position. In some aspects of the disclosure, the ball net structure 10 can comprise at least one attachment device 35 that can receive an attachment cord 32 having a ring 34. The attachment cord 32 allows for the connection of a weight, stake or similar device to provide additional support for the ball net structure 10. In the aspect of FIG. 1, the attachment device 35 is a loop-like device that is coupled to the base structure 12 and allows the attachment cord 32 to be tied or coupled to the attachment device 35. The attachment cord 32 can be a bungee cord, rope, or the like. The ring 34 allows for a weighted or force-resistant device (not shown), such as but not limited to a sandbag or a suction cup, to be attached to the base structure 12 to provide additional support for the ball net structure 10 and prevent the ball net structure 10 from moving, falling over, or shifting. The ring 34 can also be used to receive a stake, staple, hook or similar device that

12

is inserted into the ground or surface so as to attach the ball net structure 10 to the ground or surface.

The attachment device 35 is configured to extend laterally or horizontally from the base structure 12, such that the weight or similar device attached to the cord 32 provides a lateral support, which prevents the ball net structure 10 from lifting upwards or shifting its position. In some aspects, the net 30 can be received by the attachment device 35, such that the sleeve 33 of the net 30 is coupled to the attachment device 35. The attachment device 35 allows for both the sleeve 33 and the cord 32 to be coupled to the attachment device 35. An advantage of this arrangement is that the weight or similar device attached to the attachment device 35 can also act as a shock absorber when a ball or projectile is caught or captured by the ball net structure 10. The force of the ball is distributed throughout the ball net structure 10 and also partially transferred to the weight or device attached to the attachment device 35, which further provides additional support to the ball net structure 10 which increases the stability and/or the force the ball net structure 10 can withstand. In other aspects of the disclosure, the ball net structure 10 comprises a plurality of attachment devices 35 and can be disposed on the base structure 12 and/or on base extensions 18, 20.

FIG. 5 shows one aspect of a ball net structure 500 according to the disclosure.

The ball net structure 500 comprises a base structure 502 comprising a first support portion 504, a first base extension 512, and a first base extension hinge 508, wherein the first support portion 504 and first base extension 512 are coupled to the first base extension hinge 508. The base structure 502 further comprises a second support portion 506, a second base extension 514, and a second base extension hinge 510, wherein the second support portion 506 and second base extension 514 are coupled to the second base extension hinge 510. The first support portion 504 is configured to receive the second support portion 506, such that the second support portion 506 is removably coupled to the first support portion 504. At least one rod 516 is removably coupled to the base structure 502 and is received by a net 520. The net 520 is adapted to exert a pulling force on the at least one rod 516 such that the at least one rod 516 is in a flexed state. The first and second base extensions 512, 514 are adapted to support the load of the ball net structure 500 and allow the ball net structure 500 to remain upright on a surface. The first and second base extensions 512, 514 absorb at least part of the load exerted onto the ball net structure 500 from a ball or other projectile when in use so as to maintain the ball net structure 500 in an upright position.

In one aspect, as shown in FIGS. 6-9, the first support portion 504 is configured to receive the second support portion 506, such that the second support portion 506 is removably coupled to the first support portion 504. In one aspect, the second support portion 506 can be hollow and comprise an open end 602 that allows part of the first support portion 504 to be at least partially inserted the open end 602 and at least partially received within the second support portion 506. In some aspects, the second support portion 506 can comprise a hollow cavity 604 extending from the open end 602 to an opposing end 603 of the second support portion 506 that is received by the second base extension hinge 510. In some aspects, the hollow cavity 604 can extend various lengths from the open end 602 and is not intended to be limited to the aspects disclosed herein. The second support portion 506 being hollow allows the positioning of the first support portion 504 within the second support portion 506 to be adjustable. In some aspects, the

13

position of the first support portion **504** can be adjusted by sliding the first support portion **504** within the hollow cavity of the second support portion **506**.

The position of the first support portion **504** within the second support portion **506** can be secured such that the first support portion **504** and second support portion **506** are coupled. In one aspect, the first support portion **504** comprises a locking pin **507** and the second support portion **506** comprises a plurality of openings **509**, wherein the locking pin **507** engages one of the plurality of openings **509** to couple the first and second support portions **504**, **506** together. The locking pin **507** securely fastens the first and second support portions **504**, **506** and maintains the structural connection between the first and second support portions. In one aspect, the locking pin **507** can be a push button pin within the first support portion **504**, wherein the push button pin is depressed to release the connection of the locking pin and the opening **509**, allowing the first support portion **504** to be removably coupled to the second support portion **506**. In other aspects, the locking pin **507** can be a pin that is external to the first support portion **504** that is inserted into one of the plurality of openings **509** to couple the first and second support portions **504**, **506**. In such aspect, the first and second support portion **504**, **506** can comprise a plurality of openings **509** wherein the pin is inserted into aligned openings **509** of the first and second support portions **504**, **506** to couple the first and second support portions **504**, **506**. In other aspects, the locking pin can be a screw, stake, or the like. The disclosure is not intended to be limited to a locking pin, and can be configured in many different ways, such that the second support portion and the first support portion are coupled.

The first and second support portions **504**, **506** can be configured in many different ways and are not intended to be limited to the aspects disclosed herein. For example, in one aspect, the first support portion **504** can be coupled to an exterior surface of the second support portion **506**, wherein the first support portion can be secured along different points of the outer surface of the second support portion. In yet other aspects, an intervening structure could be present to connect the first and second support portions **504**, **506** together, such as but not limited to the hinge **22** of FIG. **1** discussed above, or a hinge similar to the base extension hinge **508** discussed herein. The first support portion **504** and/or the second support portion **506** can be permanently coupled to the intervening structure or removably coupled to the intervening structure, while yet being able to adjust the positioning of either first support portion or the second support portion with respect to the intervening structure and/or the opposing support portion. In some aspects, the first and/or second support portions can be telescopic support portions such that each can comprise one or more portions that can extend and/or retract such that the size of the first and/or second support portion can be adjusted.

In one aspect, the first and second support portions **504**, **506** are axially aligned along the same axis, such that the first support portion **504** is received within the second support portion **506**. The positioning of the first and second support portions can be adjusted by sliding at least one of the first and/or second support portions with respect to the other support portion. For example, in the aspect of FIG. **7**, the first support portion **504** is received within the second support portion **506**, wherein the locking pin **507** is engaged with the opening **509** that is opposite the open end **602** of the second support portion **506**. Disengaging the locking pin **507** from the opening **509** allows the positioning of the first support portion **504** within the second support portion **506** to

14

be adjusted. With reference to FIG. **8**, the first support portion **504** can be adjusted to be removably coupled to the second support portion **506** at the opening **509** proximate the open end **602** of the second support portion **506**. In the aspect of FIG. **7**, the first and second support portions **504**, **506** are locked in a first configuration. The configuration can be altered by adjusting the positioning of the first support portion within the second support portion, such that the first and second support portions are locked in a second configuration, as shown in FIG. **8**. The positioning of the first support portion **504** within the second support portion **506** can be easily adjusted by disengaging the locking pin **507** from the at least one openings **509** and engaging the locking pin **507** in the desired at least one openings **509**. The adjustability of the first and second support portions **504**, **506** allows the base structure to be configured into different sizes, thereby allowing different nets to be used with the ball net structure. In the aspect of FIG. **7**, the size of the base structure is smaller in comparison to the size of the base structure shown in FIG. **8**. The first support portion **504** can be easily adjusted from the configuration disclosed in FIG. **8** back to the configuration disclosed in FIG. **7** by disengaging the locking pin **507** and sliding the first support portion **504** into the second support portion **506** and engaging the locking pin **507** with the opening **509** that is opposite the open end **602** of the second support portion **506**.

The first and second support portions **504**, **506** can be configured in many different ways and are not intended to be limited to the aspects disclosed herein. In the aspects of FIGS. **7** and **8**, the second support portion **506** comprises two openings **509**, but in other aspect, the second support portion **506** can comprise a plurality of openings **509** such that the first support portion **504** can be coupled to the second support portion at any one of the plurality of openings. In yet other aspects, the respective lengths of the first and second support portions can be the same and/or different. In yet other aspects, the first and second support portions are not axially aligned. The first and second support portion can be arranged in many different ways and are not intended to the aspects disclosed herein. For example, the first and second support portions can be parallel with respect to each other, while in other aspects, the first and second support portions could be arranged at an angle with respect to each other. In yet other aspects, the position of the first support portion can be adjusted with respect to the second support portion while not being received by the second support portion.

At least one advantage of the disclosure is the ability to alter the configuration of the base structure. The configuration of the base structure can be altered, in part, due to the positioning of the first and second support portions **504**, **506** being adjustable. The adjustability of the positioning of the first and second support portions allows the first support portion to be secured along different openings of the second support portion, thereby allowing the base structure to be adjusted to different sizes. The base structure being adjustable to different sizes allows the ball net structure to be used with nets of different sizes and/or configurations. The base structure is compatible with various sized nets that can be used for different activities. In some aspects, the separation of the first and second base extension hinges can be determined, in part, by the length of the first and/or second support portions and/or by the positioning of the first support portion within the second support portion. In the aspects of FIGS. **7** and **8**, the first and second support portions are similar in length and the separation of the first and second base extension hinges is altered by adjusting the positioning

15

of the first support portion within the second support portion. In some aspects, the nets that are compatible with the disclosure are based, in part, by the separation of the first and second base extension hinges. However, in other aspects, the nets compatible with the disclosure do not depend on the separation of the first and second base extension hinges. Typically, nets are used with a dedicated frame structure that is only intended to be used with one type of net, and is not able to be adjusted so that a different net can be used on the dedicated structure. As such, users would have to purchase multiple dedicated net framing structures each using a different net for different sports-related activities and/or training, which can be costly. The disclosure allows different nets to be used on the same base structure by adjusting the base structure as needed, so that users would only have to purchase the nets and not multiple framing structures of the net.

The base structure 502 of the ball net structure 500 comprises a first base extension hinge 508 and a second base extension hinge 510. The first and second base extension hinges 508, 510 receive the respective first and second support portions 504, 506, as shown in FIG. 5. The first and second base extension hinges 508, 510 further receive the respective first and second base extensions 512, 514, as also shown in FIG. 5. In the aspect of at least FIG. 5, the base structure 502 comprises two first base extensions 512 and two second base extensions 514, but it is understood that the base structure can comprise one or more first base extensions and/or one or more second base extensions and is not intended to be limited to the aspects disclosed herein.

The first and second base extension hinges 508, 510 can be substantially similar. As such, a discussion of the first base extension hinge 508 will be presented herein with the understanding that such disclosure can be applicable to the second base extension hinge 510, in an effort to reduce duplicate descriptions. However, the disclosure does not require the first and second base extensions hinges to be identical. In some aspects, the first and/or second base extension hinge 508, 510 can comprise some of the same elements disclosed herein. While in other aspects, the first and/or second base extension hinges do not necessarily comprise some of the same elements of the other base extension hinge(s). Additionally, the first and second base extensions 512, 514 can be substantially similar, and the following discussion referring to the first base extension 512 is understood to be applicable to the second base extension 514. However, the first and second base extension do not have to be identical. In some aspects, the first and/or second base extensions 512, 514 can comprise some of the same elements disclosed herein, while in other aspects, the first and/or second base extensions do not comprise some of the same elements of the other base extension(s).

The first base extension hinge 508, as shown in FIG. 10, comprises at least one groove 1002 and a pivot 1004, wherein part of the first base extension 512 is received in the at least one groove 1002 and coupled to the first base extension hinge 508 such that the first base extension 512 can pivot about the pivot 1004 within the at least one groove 1002. The at least one groove 1002 comprises at least one groove sidewall 1006, a groove base 1008 and a groove top 1010, wherein the at least one sidewall 1006 at least partially defines the range of which the first base extension 512 can pivot within the at least one groove 1002. The first base extension hinge comprise a stop 1012 that assists in preventing substantial movement of the first base extension 512 within the at least one groove 1002. In some aspects, the stop 1012 maintains the positioning of the first base extension

16

512 while positioned at the ends of the range of pivot motion within the groove 1002, such that the first base extension 512 is secured and does not freely move. In one aspect, the range of pivot motion can comprise an opened end 1014 wherein the first base extension 512 is deployed, as shown in FIG. 12, and a closed end 1016 wherein the first base extension 512 is retracted and proximate the first support portion 504, as shown in FIG. 13. The stop 1012 provides an obstacle or physical structure to maintain the positioning of the first base extension 512 at either the opened end 1014 or the closed end 1016. The stop 1012 can be shaped to partially correspond to part of the first base extension 512 received within the groove 1002. In some aspects, the stop 1012 comprises a first edge 1013 that is proximate the first base extension 512 when positioned at the opened end 1014. In some aspects, the stop 1012 can comprise a second edge 1015 that is proximate the first base extension 512 when positioned at the closed end 1016. The stop 1012 comprises an elevated or raised surface with respect to the groove base 1008 such that the first and second edges 1013, 1015 provide a physical barrier that assists to maintain the first base extension 512 at either the opened end 1014 or the closed end 1016. The stop 1012 prevents the first base extension 512 from freely moving within the groove 1002, and assists in stabilizing the base structure 502. In some aspects, the first and second edges 1013, 1015 extend from the groove base 1008 to the same height. While in other aspects, the first and second edges 1013, 1015 extend from the groove base 1008 to different heights. In some aspects, at least part of the first and second edges 1013, 1015 can contact part of the first base extension 512 to maintain the position of the first base extension 512. The stop 1012 provides resistance to prevent slight movement of the first base extension 512, but does not prevent the first base extension 512 from moving between the opened end 1014 and the closed end 1016. The stop 1012 can be configured in many different ways and is not intended to be limited to the aspects disclosed herein. In the aspect of FIG. 10, each groove 1002 comprises one stop 1012 on the groove base 1008. However, in other aspects, each groove 1002 can comprise one or more stops 1012 on the groove base 1008. In some aspects, one or more stops 1012 can be on the at least one groove sidewall 1006, the groove base 1008, the groove top 1010, or a combination thereof.

When the first base extension 512 is positioned at the closed end 1016 of the groove 1002, the base structure 502 is in a closed state and in condition to be stored for later use. When the first base extension 512 is positioned at the opened end 1014 of the groove 1002, the base structure 502 is in a deployed condition and ready to be used. The range of pivot motion of the first base extension 512 is not intended to be limited to the aspects described herein. For example, the range of pivot motion of the first base extension 512 between the closed end 1016 and the opened end 1014 within the groove 1002 can range from about 0 to 90 degrees. However in some aspects, the range of pivot motion of each and/or some of the base extension from the closed end to the opened end of the respective groove can range from about 0 to 180 degrees. In some aspects the range of pivot motion of the base extensions can be the same, while in other aspects the range of pivot motion can be different for the base extensions.

The first base extension 512 is coupled to the first base extension hinge 508 by a pin 1018, such that the first base extension 512 is adapted to pivot within the groove 1002 about the pivot 1004. In the aspects of FIGS. 12 and 13, the first base extension hinge 508 comprises two grooves 1002, two pins 1018 and two first base extensions 512, wherein a

17

respective first base extension 512 is partially received within a respective groove 1002 and coupled to the first base extension hinge 508 by a respective pin 1018. In the aspects of FIGS. 12 and 13, each pin and base extension are opposite each other. In other aspects, the base extension hinge can comprise any number of base extensions and/or grooves, and is not intended to be limited to the aspects disclosed herein.

The first base extension hinge 508 further comprises a channel 1020 to receive the first support portion 504, as shown in FIG. 12. The channel 1020 comprises a top 1022, a base 1024, and sidewalls 1026 wherein the channel 1020 is proximate the at least one groove 1002 of the base extension hinge 508. In the aspect of FIG. 10, the first base extension hinge 508 comprises two grooves 1002 opposite each other with the channel 1020 interposed between the opposing grooves 1002. In some aspects, the channel 1020 can comprise at least one rib 1028 within the channel 1020 to assist in securing the first support portion 502 within the channel 1020. In some aspects, the at least one rib 1028 can be arranged within the channel 1020 such that the channel 1020 can accommodate the dimensions of the first support portion 504 that is received within the channel 1020, as shown in FIG. 18. In other aspects, the at least one rib 1028 can be arranged within the channel 1020 such that part of the first support portion 504 received within the channel 1020 at least partially contacts at least one of the top 1022, base 1024, sidewall 1026, and/or a combination thereof. The at least one rib 1028 at least partially extends along the length of the channel 1020. The at least one rib 1028 can be a continuous rib, while in other aspects, the at least one rib 1028 can comprise a plurality of ribs that are separated and aligned to form the at least one rib. In some aspects, the channel 1020 can comprise a plurality of ribs 1028 that contact part of the first support portion 504 that is received in the channel 1020 such that the plurality of ribs 1028 prevent the first support portion 504 from shifting and/or moving while in the channel 1020. In one aspect, the at least one rib 1028 can be at the intersection of the sidewall 1026 and the top 1022 and/or base 1024. However, the at least one rib 1028 can be arranged in many different locations within the channel 1020 and is not intended to be limited to the aspects described herein. In some aspects, the at least one rib 1028 can be on a sidewall 1026, the top 1022, the base 1024, or a combination thereof. In some aspects, the channel 1020 can comprise at least one rib 1028 at an intersection of the top 1022 and the sidewall 1026, the base 1024 and the sidewall 1026, the top 1022, the base 1024, the sidewalls 1026, or a combination thereof. The first base extension hinge 508 can further comprise a channel lock pin 1030 to couple the first support portion 504 within the channel 1020, as shown in FIG. 15. The channel lock pin 1030 in the aspect of FIG. 15 is disclosed as being at a bottom surface 1032 of the first base extension hinge 508. However, the channel lock pin 1030 is not intended to be limited to the aspects described herein. In some aspects, the channel lock pin 1030 can be at the top surface or any other surface of the first base extension hinge 508 in order to couple the first support portion 504 within the channel 1020.

The first base extension hinge 508 can further comprise at least one cavity 1034, wherein the at least one cavity 1034 is interposed between the groove 1002 and the channel 1020. In the aspect of FIG. 10, the first base extension hinge 508 comprises two cavities 1034, wherein each cavity 1034 is interposed between the channel 1020 and a respective groove 1002. The cavity 1034 provides a separation between the channel 1020 and the groove 1002 to allow for the first

18

support portion 504 to be separated from the first base extension 512 when the first base extension 512 is positioned in the closed end 1016 within the groove 1002. With reference to FIGS. 13-14, the separation between the first support portion 504 and the first base extension 512 prevents the first base extension 512 from hitting and/or striking the first support portion 504 when being positioned into and/or when positioned in the closed end 1016. The separation assists in preventing damage to either the first support portion 504 and/or the first base extension 512, which can prolong the durability of the ball net structure 500. In some aspects, the at least one cavity 1034 can comprise at least one bridge 1036, as shown in FIG. 12. The at least one bridge 1036 can extend between the channel 1020 and the groove 1002. The at least one bridge 1036 can provide further structural support to the first base extension hinge 508, and assist the first base extension hinge 508 in withstanding loads and/or forces exerted onto the ball net structure 500.

FIGS. 18 and 19 show an aspect of the first base extension hinge 508, wherein the first base extension hinge 508 is angled such that when the at least one first base extension 512 is deployed, at least the first base extension hinge 508 is raised off the ground or surface a distance "d" and part of the at least one first base extension 512 is on the ground or surface. In one aspect, the at least one groove 1002 of the first base extension hinge 508 is set at an angle towards the ground or surface. As a result, the first support portion 504 and the first base extension hinge 508 of the base structure 502 are raised off the ground or surface by at least the distance "d" while part of the at least one first base extension 512 is on the ground. In some aspects, a base extension end 513 of the first base extension 512 is opposite the first base extension hinge 508 and contacts the ground or surface when the first base extension 512 is deployed, as shown in FIG. 19. However, in some aspects, at least a portion of the first base extension 512 contacts the ground or surface when deployed. The angle of the at least one groove 1002 can be set at any degree towards the ground or surface, and in some aspects can be within a range of 0 to 90 degrees. In the aspects of FIGS. 18 and 19, the first base extension hinge 508 comprises two grooves 1002 and two first base extensions 512, wherein each groove 1002 is angled such that the first base extension hinge 508 and first support portion 504 are raised off the ground when the first base extensions 512 are deployed. The disclosure is not intended to be limited to the aspects disclosed herein. In other aspects, the first base extension hinge 508 can comprise one or more grooves 1002. In such aspects, the one or more grooves 1002 can be angled with respect to the surface, wherein the one or more grooves 1002 are set to the same or different angle. In yet other aspects, the one or more grooves 1002 are not angled with respect to the surface such that the one or more grooves 1002 are substantially parallel to the surface. While in other aspects, one groove 1002 can be angled with respect to the surface while another groove 1002 is not angled with respect to the surface.

The first base extension hinge 508 can further comprise at least one attachment device 1038 to assist in stabilizing the ball net structure 500 to the surface. With reference to FIGS. 11 and 14-16, the base extension hinge 508 can comprise an attachment device 1038 at the bottom surface 1032 of the first base extension hinge 508, wherein the attachment device 1038 is an extension that extends from the bottom surface 1032 of the first base extension hinge 512. The attachment device 1038 can receive an attachment cord 1040 comprising a ring 1042 which is adapted to provide addi-



tional structural support. The ring 1042 can receive a stake, weight, or similar device so as to attach the ball net structure to the ground or surface. The at least one attachment device 1038 is configured to further provide additional structural support to the ball net structure 500 which increases the stability and/or the force the ball net structure 500 can withstand. Furthermore, the at least one attachment device 1038 can also be used to maintain the positioning of the ball net structure 500 to prevent shifting of the ball net structure 500. In other aspects of the disclosure, the ball net structure 500 comprises a plurality of attachment devices 1038 and can be on the first support portion 504 and/or the first base extensions 512. In yet other aspects, the attachment device 1038 can be located on different locations on the first base extension hinge 508 and is not intended to be limited to being at the bottom surface 1032. In yet other aspects, an attachment device 1038 can be on at least one of the first support portion 504, first base extension hinge 508, first base extensions 512, and/or a combination thereof.

The first base extension hinge 508 further comprises a shaft 1044 extending from a top surface 1031 of the first base extension hinge 508. In some aspects, the shaft 1044 extends outward in a direction towards a back surface 1033 of the first base extension hinge 508. The shaft 1044 can be angled at an angle  $\theta$  (theta) with respect to the back surface 1033 of the first base extension hinge 508, as further shown in FIG. 11. In one aspect, the shaft 1044 can be angled at an angle  $\theta$  of approximately 26 degrees. However, the angle  $\theta$  can be many different angles and is not intended to be limited to 26 degrees. In some aspects, the shaft 1044 can be angled at an angle  $\theta$  within the range of 0 and 90 degrees. In some aspects, the shaft 1044 can comprise at least one fin 1046, wherein the at least one fin 1046 provides structural support to the first base extension hinge 508 and/or the shaft 1044. The at least one fin 1046 can comprise a planar body 1048 that is coupled to the shaft 1044 and to part of the top surface 1031 of the first base extension hinge 508. The at least one fin 1046 stabilizes the shaft 1044 and assists to withstand forces exerted onto the shaft 1044. The at least one fin 1046 can also assist in withstanding forces exerted onto any part of the ball net structure 500, such as but not limited to the base extension hinge, base extension, support portion, and/or any elements of the ball net structure 500. In the aspect of FIGS. 10-11, the shaft 1044 comprises three fins 1046. However, in other aspects, the shaft 1044 can comprise one or more fins 1046 and is not intended to be limited to the aspects disclosed herein. In some aspects, the at least one fin 1046 can comprise an attachment device 1038, similarly as disclosed above. The attachment device 1038 of the at least one fin 1046 can be configured to receive the attachment cord 1040 as discussed above to stabilize the ball net structure 500. While in other aspects, the attachment device 1038 of the at least one fin 1046 can receive part of a net 520, such as but not limited to a sleeve 524. The attachment device 1038 of the at least one fin 1046 can be configured in many different ways and is not intended to be limited to the aspects disclosed herein. In some aspects, the attachment device 1038 of the at least one fin 1046 can comprise at least one tab extending from the planar body 1048. In other aspects, the attachment device 1038 of the at least one fin 1046 comprises a notch formed within the planar body 1048. In yet other aspects, the attachment device 1038 of the at least one fin 1046 comprises an aperture in the planar body 1048 and a stud within the aperture extending from the planar body 1048.

The shaft 1044 is configured to receive a rod 516. The rod 516 is securely held within the shaft 1044, such that the shaft

1044 maintains a stable structural connection between the shaft 1044 and the rod 516 and prevents the rod 516 from being removed from the shaft 1044 when the ball net structure 500 is assembled. In one aspect of the disclosure, the shaft 1044 is similarly shaped as the rod 516, such as but not limited to cylindrically shaped, and can be larger than the rod 516 such that the rod 516 can be easily received by and/or removed from the shaft 1044. In some aspects, the shaft 1044 can comprise a sheath contacting at least part of an inner wall of the shaft 1044 that receives the rod 516. The sheath is adapted to protect the rod 516 within the shaft 1044 from forces exerted on the rod 516. As discussed above in the aspects of FIGS. 1-4, and discussed below, the rods 516 experience a moment force proximate where the rod 516 is received by the shaft 1044, and causes the rod 516 to exert a compression force upon the inner surface of the shaft 1044. The sheath, if present, protects the rod 516 from the forces exerted on and/or by the rod 516.

The shaft 1044 can be arranged in many different ways and is not intended to be limited to the aspects disclosed herein. In some aspects, the shaft 1044 can comprise a tapered inner surface such that the radius of the shaft 1044 decreases as the rod 516 is further inserted into the shaft 1044. In such aspect, the shaft 1044 applies a compression force onto the rod 516 to form a structural connection with the rod 516. In other aspects, mechanical devices, such as but not limited to, screws, nuts, nails, rivets or the like, can be used to form the structural connection to securely attach the rod 516 to the shaft 1044. In yet other aspects, the rods 516 can comprise an attachment device such that the rods 516 can be attached to the shaft 1044; non-limiting examples of such attachment devices are the rods 516 being threaded and screwed into the shaft 1044 or the rod 516 and shaft 1044 configured similarly like a bayonet-type locking device.

In the aspect of FIG. 5, the rods 516 are circularly shaped and the shaft 1044 is also correspondingly circularly shaped to receive the rod 516. The shape of the rod 516 and shaft 1044 is not intended to be limited to a circular shape, other shapes such as quadrilateral, triangular, or any other polygonal shape can be used. The shaft 1044 can also be similarly shaped as the rod 516, but in some aspects, the shaft 1044 can be shaped differently than the rod 516. The rods 516 can be made of many different materials known in the art, such as but not limited to fiberglass or carbon fiber, such that the rods 516 are flexible, elastic, capable of returning to an initial form or state after deformation, and able to withstand the impact forces applied by sports-related balls and/or other projectiles that can be captured or caught by the ball net structure 500, or thrown, kicked, and/or hit towards the ball net structure 500.

The angle at which the shaft 1044 is angled with respect to the back surface 1033 of the first base extension 508 causes the rod 516 to extend outward at substantially the same angle as that of the shaft 1044. The rods 516, when received by the shaft 1044 flare outwards, such that the rods 516 are in a relaxed state and are substantially straight. A net 520 is arranged to receive the at least one rod 516 of the ball net structure. In some aspects, the net 520 comprises at least one sleeve 524 to receive part of at least one rod 516 of the ball net structure 500. The net 520 is adapted to exert a force on the at least one rod 516 bending the at least one rod 516 into a flexed state. The at least one rod 516 received by the at least one sleeve 524 results in the at least one rod 516 being bent from the relaxed state into a flexed state. In the aspect of FIG. 5, the ball net structure 500 comprises two rods 516, wherein each rods 516 is received by a respective

21

shaft **1044** and at least one respective sleeve **524** of the net **520**, such that both rods **516** are bent in a direction towards the base structure **502** and into the flexed state. Removal of the net **520** from at least one rod **516** allows the rods **516** to return to their original form of the relaxed state. When the at least one rod **516** is in the relaxed state, the at least one rod **516** can be easily removed from the shaft **1044** and allows the ball net structure **500** to be disassembled and stored for later use. Repeated use of the ball net structure **500** does not result in the rods **516** being permanently bent in a shape similar to that of the flexed state. In other aspects, when the at least one rod **516** is in the relaxed state, the base structure **502** can be configured into a different configuration to allow a different net to be used with the base structure **502**.

The net **520** is similar to the net **30**, discussed above, and imparts a pulling force on each of the rods **516** which causes the rods **516** to bend in a direction towards the base structure **502**. Once bent towards the base structure **502**, the rods **516** are in the flexed state and experience a moment force about its pivot point. The pivot point of each of the rods **516**, in the aspect of FIG. 5, corresponds to the point at which the rods **516** are received by the shaft **1044**. The moment force experienced by the rods **516** is imparted onto at least the base structure **502** and the first and second support portions **504**, **506** of the base structure **502**, with the transferred force being greatest at a central region of the base structure **502**. This transferred force further assists in stabilizing the base structure **502** on the surface which the ball net structure **500** is on.

The net **520** can comprise a mesh surface and/or can be comprised of typical net materials known in the art. The net **520** comprises at least one sleeve **524** to receive a rod **516** and/or the base structure **502**. The aspect of FIG. 5 shows the net **520** comprising a plurality of sleeves **524** that at least partially extend along opposing edges of the net **520**, such that the sleeves **524** are opposite each other. The sleeves **524** of the aspect of FIG. 5 are in the form of sleeves of varying sizes on opposing edges of the net that are adapted to receive a respective rod **516**. For example, on one edge the net comprises an elongated sleeve that extends along part of the edge of the net, and two smaller sleeves that are proximate a respective corner region of the net. The elongated sleeve is adapted to extend along part of the rod, and the smaller sleeves are adapted to be removably coupled to an end of the rod and/or base structure. The sleeves **524** of the net **520** can be configured in many different configurations and are not intended to be limited to the aspects disclosed herein. In some aspects, the sleeve can span the length of the rod. In other aspects, the sleeve can comprise a plurality of smaller sleeves or loops that are spaced apart from each other and run along part of the rods **516**, or can comprise a sleeve that spans along a partial length of the rod **516**, or can comprise a plurality of sleeves of various lengths. The at least one sleeve of the net can be arranged in many different shapes, such as but not limited to at least one sleeve that extends along a substantial portion of the rod **516**, a plurality of sleeves **524** that extend along part of the rod **516**, or a combination thereof. In some aspects, the sleeves are fixedly attached to the net. Whereas in other aspects, the sleeves comprise an attachment mechanism in order to removably couple the sleeves to the rod and/or base structure. In some aspects, the attachment mechanism can comprise a hook and loop system, such that the sleeves are removably coupled via the hook and loop system. In other aspects, the attachment mechanism can comprise a hook, latch, or the like in order to removably couple the sleeve to the rod and/or the base

22

structure. The sleeves **524** receive the rods **516** and securely hold the net **520** on the rods **516** due in part to the sleeves **524** bending the rods **516**.

In some aspects, the net can comprise at least one sleeve **524** adapted to be removably coupled to the rod **516**. In some aspects, the net **520** can comprise at least one sleeve **524** received by an end portion of the rod **516**, opposite the shaft **1044**, and at least one sleeve **524** that extends along part of the rod. In some aspects, the net **520** can comprise at least one sleeve **524** that is removably coupled to the base structure **502**, which assists in holding the net **520** onto the base structure **502**. In some aspects, the base extension hinge **508** comprises an extension **1039** at the back surface **1033** of the base extension hinge **508** that allows for connection of the at least one sleeve **524** to the extension **1039**. The extension **1039** can be at many different locations on the base extension hinge **508** and is not intended to be limited to the back surface **1033** of the base extension hinge **508**. In some aspects, the extension **1039** can be on any part of the base structure **502**, such as but not limited to the first and/or second support portions **504**, **506**, the first and/or second base extensions **512**, **514**, or a combination thereof. In yet other aspects, the base structure **502** can comprise a plurality of extensions **1039** to allow for the connection of at least one sleeve **524**. In the aspect of FIG. 11, the extension **1039** is in the form of a tab that extends out from the base extension hinge. However, in other aspects, the extension **1039** can be arranged in many different configurations and is not intended to be limited to the aspects disclosed herein. In some aspects, the extension **1039** can be in the form of a loop coupled to the base structure. In some aspects, the at least one attachment device **1038** can also be configured to receive part of the net and/or at least one sleeve **524**. In some aspects, the net **520** can comprise at least one sleeve **524** adapted to receive part of at least one of the first and second support portions **504**, **506**. While in other aspects, the net **520** can comprise a plurality of sleeves that receive a respective one of the first and second support portions **504**, **506**, first and second base extensions **512**, **514**, first and second base extension hinges **508**, **510**, or a combination thereof. The sleeves that receive the support portion and/or base extension can extend along the edge of the net that is proximate the base structure. The at least one sleeve **524** of the net can be comprised of many different materials, such as but not limited to fabric, plastic, elastic material, rope, cord, or the like.

Each rod **516** comprises an endcap **518** opposite the portion of the rod **516** that is received by the shaft **1044**. The endcap **518** is configured to receive at least a portion of the sleeve and/or loop **524**, such that the endcap **518** prevents the net **520** from coming off the rods **516** while the ball net structure **500** is assembled and/or in use. In some aspects, the endcaps **518** comprise a tab and a notch adapted to prevent the net **520** from coming off the rod **516**. For example, the endcap **518** comprises a tab and a notch proximate the tab, such that the notch provides a depressed surface that receives the sleeve and/or loop **524** such that the sleeve and/or loop is securely held by the endcap **518** within the notch. In other aspects, the net **520** can comprise a keyhole clip configured to be removably coupled to the endcap **518**. In one aspect, the keyhole clip comprises a housing comprising an opening, a groove, and a cover, wherein the keyhole clip is received by the endcap **518**. In one aspect, the tab of the endcap **518** is received by the opening the keyhole clip and is slidably received with the groove, such that the notch of the endcap **518** is sized to fit and be removably coupled to the groove of the keyhole clip.

23

The keyhole clip is thereby securely held by the endcap and is prevented from coming off the endcap while the ball net structure is assembled and/or in use. The cover of the housing covers the groove and opening, such that when the keyhole clip is received by the endcap, the cover covers the endcap and assists in maintaining the net on the rod. At least one advantage is that the keyhole clip provides for ease of installing and/or coupling the net **520** onto the rods **516**. In addition, the keyhole clip being securely held by the endcap assists in keeping the net on the rods in the event that a ball and/or other projectile hits the net proximate the endcap. However, in other aspects, the endcaps **518** can have other means of preventing the net **502** from coming off the rods **516**, such as but not limited to a hook, loop, locking clip, or the like.

At least one advantage of the disclosure is that the base structure **502** can compensate for forces exerted onto the base structure by the rods **516** while in the flexed state. When the net **520** is coupled and/or received by the rods that are within the respective shafts of the base extension hinge, the net exerts a pulling force onto the rods, such that the rods are in the flexed state. The rods in the flexed state exert a force onto at least the support portions **504**, **506** of the base structure, and raising at least the support portions off the ground or surface allows the base structure to compensate for the force exerted onto the base structure by the rods in the flex state. The base structure can absorb the load exerted onto the support portions due to the rods being in the flexed state and distribute the load across the base structure. In one aspect, the raised support portions allows the base structure to at least partially oscillate and/or bow to dampen the load from the rods. If the support portions of the base structure were to remain on the ground, the force exerted onto the base structure by the rods in the flexed state could cause the base structure to bend and become deformed. Thus, the base extension hinges being angled such that the base extensions raise the base structure when the base extensions are deployed, seeks to counteract the force exerted onto the base structure from the rods. In other aspects, the first and/or second support portions can be bent to at least partially raise part of the first and/or second support portions in order to counteract the downward force exerted onto the base structure **502** by the rods **516** bent in the flexed state. In other aspects, the base extensions can be bent to raise the base structure when the base extensions are deployed.

The base extensions can be configured in many different configurations and are not intended to be limited to the aspects of the disclosure herein. The base extensions of at least FIGS. **18** and **19** are shown as being straight or linear. However, the base extensions are not intended to be limited to being straight or linear. In some aspects of the disclosure, the base extensions can be bent such that the bent base extensions raise the base structure off the ground or surface by the distance "d" when the base extensions are deployed. The bent base extension could be used with the angled base extension hinge to further assist in lifting the base structure from the ground or surface. In some aspects, the at least one grooves of the base extension hinge are not angled towards the ground, such that the base extension hinge is flat with respect to the ground or surface. In such aspects, the base extensions and/or the support portions can be bent such that the base structure is at least partially raised off the ground or surface. In yet other such aspects, the base extension hinge can further comprise feet that lift the base extension hinge off the ground or surface such that at least the support portions are raised off the ground or surface. In another aspect, the at least one groove of the base extension hinge

24

can be angled away from the ground. In such aspects, the base extensions and/or support portions can be bent in order to at least partially lift the base structure off the ground or surface, or the hinge can also comprise feet that lift the base extension hinge off the ground, or a combination thereof.

The base extension hinge can be configured in many different configurations and is not intended to be limited to the aspects disclosed herein. For example, in some aspects, the base extension hinge has a general semi-circular shape, but in other aspects, the base extension hinge can comprise many different shapes and not limited to a semi-circular shape. In other aspects, the base extension hinge can comprise one groove or more than one groove. For example, in FIGS. **18** and **19**, the base extension hinges comprise two grooves and a base extension pivotable within a respective groove. Additionally, the grooves are set at an angle such that the bottom surface of the base extension hinge is not substantially flat. As discussed above, the angled grooves of the base extension hinge causes the base extensions to lift the base structure when the base extensions are deployed or positioned at the opened end of the groove. Furthermore, the stop within the groove can be a raised surface that corresponds to the shape of the base extensions to prevent rotation of the base extension within the groove. In other aspects, the base extension hinge can further comprise a locking pin and/or other locking mechanism in addition to the stop to further assist in preventing the rotation of the base extension within the groove.

The base extension hinge can be formed of many different materials. In one aspect, the base extension hinge can be comprised of plastic materials, fabricated using an injection molding process. With reference to FIGS. **10**, **14**, **16** and **17**, the base extension hinge can comprise a hole at the back surface that is aligned with the stop within the groove. The holes at the back surface are formed due to the injection molding process. The mold used to injection mold the base extension hinge comprises at least one tab wherein the material used to form the base extension hinge surrounds the at least one tab and forms the stop within the groove, such that when the mold is removed and the tab is extracted, the base extension hinge is formed and comprises the hole at the back surface of the base extension hinge. An advantage of the disclosure is that the base extension hinge is of solid construction and is not formed of separate components that are joined together. The unitary construction of the base extension hinge results in a stronger device and can bear the load of the rods exerted onto the base structure. The base extension hinge can further comprise support extensions extending from one or more surfaces of the shaft to further support the ball net structure when fully deployed and/or to withstand the force exerted by the rods onto the shaft when the net is coupled to the rod and/or when the rod is in the flexed state.

The base structure of the ball net structure can be configured in many different ways and is not intended to be limited to the aspects shown herein. The base structure of FIG. **5** is disclosed as having an "I" like shape, due to the base structure comprising two first base extensions and two second base extensions. In some aspects, the base structure can comprise one first and one second base extension. In other aspects, the base structure can be arranged to be shaped into many different shapes. For example, the base structure can be shaped similar to a soccer goal, lacrosse goal, baseball backstop, etc. The advantage of the disclosure is that the ball net structure can be configurable to many different arrangements to be used for many different sports, such as but not limited to, baseball, soccer, volleyball,

25

tennis, lacrosse, football, and the like. For example, in aspects when the at least one rod 516 is in the relaxed state, the base structure 502 can be configured into a different configuration to allow a different net to be used with the base structure 502. The positioning of the first and second support portions can be altered to either increase or decrease the size of the base structure, while in some aspects, the first and/or second base extensions can receive an extension end bracket 200 configured to receive a rod to form a soccer-like goal structure, as shown in FIG. 20, wherein a soccer goal net can be used with the transformed base structure 502, as shown in FIG. 21, wherein the soccer goal net is received by the altered base structure 502, as disclosed herein and can also be adapted to be received by the extension end bracket 200, the base extensions, or a combination thereof. The extension end bracket 200 can comprise an attachment device and/or an extension similar to the attachment device 1038 and/or the extension 1039 described above. In the aspect of FIG. 20, the adjustable base structure 502 is shown with an intervening structure, such as the hinge 22, while at least one of the first and second support portions can be configured to be telescoping as discussed above such that the length of the at least one of the support portions can be adjusted. In other aspects, the adjustable base structure 502 does not comprise the intervening structure, and the base structure is adjustable by altering the position of the first support portion 504 with respect to the second support portion 506. In addition, once the base structure 502 is configured to receive a different net, such as but not limited to a soccer goal net, the base extensions that do not receive the extension end bracket can be moved to the closed end within the groove of the base extension hinge, or they can remain deployed.

Although the disclosure has been described in considerable detail with reference to certain configurations thereof, other versions are possible. Ball net structures according to the disclosure can be many different sizes and can be used for many different applications, other than for sports-related activities. The ball net structure can comprise net sidewalls to form an enclosure, similar to a soccer goal, lacrosse goal or the like and can also include a plurality of hinges coupled to the support portions and/or the base extensions of base structure and support the force exerted onto the base structure of the ball net structure. In other aspects, the support portions can be adjustable to make a smaller or bigger base structure, while the size of the rods can also be adjusted to make a smaller or bigger ball net structures. In other aspects, the rods can be made of a single piece of material, whereas

26

in other aspects, the rods can be comprised of a plurality of rod pieces that are joined together to form the rod. Therefore, the spirit and scope of the disclosure should not be limited to the versions described above.

We claim:

1. A net apparatus, comprising:

a base structure comprising at least one support portion, at least one base extension coupled to said at least one support portion, and at least one base extension hinge, wherein said at least one support portion and said at least one base extension are coupled to said at least one base extension hinge;

said base extension hinge comprising:

at least one groove and a pivot within said at least one groove;

at least one stop within said at least one groove;

wherein part of said at least one base extension is received in said at least one groove and coupled to said base extension hinge such that said at least one base extension can pivot about said pivot;

a channel configured to receive said at least one support portion, wherein said channel is proximate said at least one groove such that there is at least some separation between said channel and said at least one groove;

a shaft comprising an insertion end to receive said at least one flexible rod, said shaft tilted outward opposite said channel; and

an extension configured to receive part of said net;

a plurality of flexible rods coupled to said base structure, said plurality of flexible rods comprising an endcap on said plurality of flexible rods opposite where said plurality of flexible rods are coupled to said base structure; and

a net, coupled to the plurality of flexible rods and the base structure, said net being retained on said net apparatus by coupling said net to said endcap, in which said net comprises a plurality of sleeves such that at least a first sleeve in said plurality of sleeves is coupled to one of said plurality of flexible rods and at least a second sleeve in the plurality of sleeves is coupled to said base structure, such that at least one sleeve in the plurality of sleeves exert a force on said plurality of flexible rods at a point where said plurality of flexible rods are coupled to said base structure, said force bending said plurality of flexible rods into a bow-shaped flexed state.

\* \* \* \* \*