



US009795373B2

(12) **United States Patent**  
**Sengun**

(10) **Patent No.:** **US 9,795,373 B2**  
(45) **Date of Patent:** **\*Oct. 24, 2017**

(54) **SYSTEMS, DEVICES, AND METHODS FOR SECURING TISSUE USING A SUTURE HAVING ONE OR MORE PROTRUSIONS**

(71) Applicant: **Medos International Sàrl**, Le Locle (CH)

(72) Inventor: **Mehmet Sengun**, Canton, MA (US)

(73) Assignee: **MEDOS INTERNATIONAL SÀRL**, Le Locle (CH)

(\* ) Notice: Subject to any disclaimer, the term of this patent is extended or adjusted under 35 U.S.C. 154(b) by 103 days.  
This patent is subject to a terminal disclaimer.

(21) Appl. No.: **14/711,959**

(22) Filed: **May 14, 2015**

(65) **Prior Publication Data**  
US 2015/0238183 A1 Aug. 27, 2015

**Related U.S. Application Data**  
(60) Continuation of application No. 14/522,562, filed on Oct. 23, 2014, now Pat. No. 9,034,013, which is a (Continued)

(51) **Int. Cl.**  
**A61B 17/04** (2006.01)  
**A61L 17/00** (2006.01)  
**A61B 17/06** (2006.01)

(52) **U.S. Cl.**  
CPC .... **A61B 17/0401** (2013.01); **A61B 17/06166** (2013.01); **A61B 2017/0403** (2013.01); (Continued)

(58) **Field of Classification Search**  
CPC ..... A61B 17/0401; A61B 2017/0409; A61B 17/0469; A61B 2017/0477; A61B 2017/0464; A61B 2017/0496 (Continued)

(56) **References Cited**

U.S. PATENT DOCUMENTS

2,566,625 A	9/1951	Nagelmann
2,600,395 A	6/1952	Domoj et al.
2,697,624 A	12/1954	Thomas et al.
2,758,858 A	8/1956	Smith
2,992,029 A	7/1961	Russell
3,106,417 A	10/1963	Clow
3,131,957 A	5/1964	Musto
3,177,021 A	4/1965	Benham

(Continued)

FOREIGN PATENT DOCUMENTS

AU	2008229746 A1	10/2008
CA	2772500 A1	9/2013

(Continued)

OTHER PUBLICATIONS

Japanese Office Action for Application No. 2011-281088, issued Nov. 10, 2015 (4 pages).

(Continued)

*Primary Examiner* — Katherine M Shi

(57) **ABSTRACT**

Systems, devices, and methods are provided for securing soft tissue to bone. One exemplary embodiment of a surgical repair construct includes an anchor, a filament having a snare formed on one end and a collapsible loop on another end, and a suture having a plurality of stationary protrusions formed therein. The suture is configured to be coupled to detached tissue and have its ends passed through an opening in the snare. The snare can be collapsed around the suture such that at least one of the suture protrusions is proximal of the collapsed snare. The anchor can be disposed in bone and the filament coupled thereto. Accordingly, collapsing the snare around the suture couples the tissue to bone, and applying tension to a tensioning limb of the filament can collapse the collapsible loop to incrementally tighten and secure the tissue to bone. Other exemplary systems, devices, and methods for use with soft tissue repair are also provided.

**20 Claims, 4 Drawing Sheets**

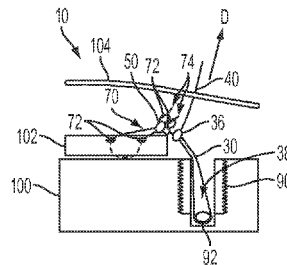
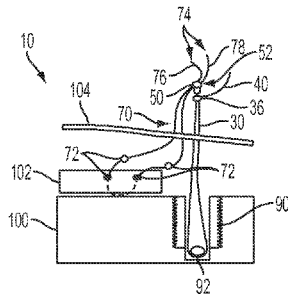

**Related U.S. Application Data**

division of application No. 13/465,362, filed on May 7, 2012, now Pat. No. 8,894,684.

(52) **U.S. Cl.**

CPC ..... *A61B 2017/0414* (2013.01); *A61B 2017/0475* (2013.01); *A61B 2017/0496* (2013.01); *A61B 2017/06176* (2013.01); *A61B 2017/06185* (2013.01)

(58) **Field of Classification Search**

USPC ..... 606/144–148, 151, 228–232  
See application file for complete search history.

(56) **References Cited**

U.S. PATENT DOCUMENTS

3,402,957 A 9/1968 Peterson  
3,521,918 A 7/1970 Hammond  
3,565,077 A 2/1971 Glick  
3,580,256 A 5/1971 Wilkinson et al.  
3,712,651 A 1/1973 Shockley  
3,752,516 A 8/1973 Mumma  
3,873,140 A 3/1975 Bloch  
4,029,346 A 6/1977 Browning  
4,036,101 A 7/1977 Burnett  
4,038,988 A 8/1977 Perisse  
4,105,034 A 8/1978 Shalaby et al.  
4,130,639 A 12/1978 Shalaby et al.  
4,140,678 A 2/1979 Shalaby et al.  
4,141,087 A 2/1979 Shalaby et al.  
4,186,921 A 2/1980 Fox  
4,205,399 A 6/1980 Shalaby et al.  
4,208,511 A 6/1980 Shalaby et al.  
4,319,428 A 3/1982 Fox  
4,403,797 A 9/1983 Ragland, Jr.  
4,510,934 A 4/1985 Batra  
4,572,554 A 2/1986 Janssen et al.  
4,792,336 A 12/1988 Hlavacek et al.  
4,870,957 A 10/1989 Goble et al.  
4,946,377 A 8/1990 Kovach  
4,962,929 A 10/1990 Melton, Jr.  
4,987,665 A 1/1991 Dumican et al.  
5,062,344 A 11/1991 Gerker  
5,098,137 A 3/1992 Wardall  
5,144,961 A 9/1992 Chen et al.  
5,156,616 A 10/1992 Meadows et al.  
5,178,629 A 1/1993 Kammerer  
5,217,495 A 6/1993 Kaplan et al.  
5,250,053 A 10/1993 Snyder  
5,250,054 A 10/1993 Li  
5,259,846 A 11/1993 Granger et al.  
5,263,984 A 11/1993 Li et al.  
5,279,311 A 1/1994 Snyder  
5,282,809 A 2/1994 Kammerer et al.  
5,284,485 A 2/1994 Kammerer et al.  
5,312,423 A 5/1994 Rosenbluth et al.  
5,318,575 A 6/1994 Chesterfield et al.  
5,320,629 A 6/1994 Noda et al.  
5,376,118 A 12/1994 Kaplan et al.  
5,391,176 A 2/1995 de la Torre  
5,395,382 A 3/1995 DiGiovanni et al.  
5,405,352 A 4/1995 Weston  
5,450,860 A 9/1995 O'Connor  
5,454,820 A 10/1995 Kammerer et al.  
5,456,722 A 10/1995 McLeod et al.  
5,464,427 A 11/1995 Curtis et al.  
5,464,929 A 11/1995 Bezwada et al.  
5,472,446 A 12/1995 de la Torre  
5,527,323 A 6/1996 Jervis et al.  
5,534,011 A 7/1996 Greene, Jr. et al.  
5,540,703 A 7/1996 Barker, Jr. et al.  
5,549,618 A 8/1996 Fleenor et al.  
5,562,684 A 10/1996 Kammerer  
5,569,306 A 10/1996 Thal  
5,571,139 A 11/1996 Jenkins, Jr.

5,573,286 A 11/1996 Rogozinski  
5,591,207 A 1/1997 Coleman  
5,593,189 A 1/1997 Little  
5,595,751 A 1/1997 Bezwada et al.  
5,597,579 A 1/1997 Bezwada et al.  
5,607,687 A 3/1997 Bezwada et al.  
5,618,552 A 4/1997 Bezwada et al.  
5,620,698 A 4/1997 Bezwada et al.  
5,628,756 A 5/1997 Barker  
5,645,850 A 7/1997 Bezwada et al.  
5,647,616 A 7/1997 Hamilton  
5,647,874 A 7/1997 Hayhurst  
5,648,088 A 7/1997 Bezwada et al.  
5,667,528 A 9/1997 Colligan  
5,683,417 A 11/1997 Cooper  
5,683,419 A 11/1997 Thal  
5,685,037 A 11/1997 Fitzner et al.  
5,698,213 A 12/1997 Jamiolkowski et al.  
5,700,583 A 12/1997 Jamiolkowski et al.  
5,702,397 A 12/1997 Goble et al.  
5,709,708 A 1/1998 Thal  
5,716,368 A 2/1998 de la Torre et al.  
5,725,556 A 3/1998 Moser et al.  
5,728,109 A 3/1998 Schulze et al.  
5,741,332 A 4/1998 Schmitt  
5,749,898 A 5/1998 Schulze et al.  
5,782,864 A 7/1998 Lizardi  
5,814,069 A 9/1998 Schulze et al.  
5,859,150 A 1/1999 Jamiolkowski et al.  
5,899,920 A 5/1999 DeSatnick et al.  
5,941,900 A 8/1999 Bonutti  
5,964,783 A 10/1999 Grafton et al.  
5,971,447 A 10/1999 Steck, III  
5,989,252 A 11/1999 Fumex  
6,024,758 A 2/2000 Thal  
6,045,574 A 4/2000 Thal  
6,143,017 A 11/2000 Thal  
6,221,084 B1 4/2001 Fleenor  
6,267,766 B1 7/2001 Burkhart  
6,296,659 B1 10/2001 Foerster  
6,319,271 B1 11/2001 Schwartz  
6,322,112 B1 11/2001 Duncan  
6,517,578 B2 2/2003 Hein  
6,527,794 B1 3/2003 McDevitt et al.  
6,527,795 B1 3/2003 Lizardi  
6,540,750 B2 4/2003 Burkhart  
6,547,807 B2 4/2003 Chan et al.  
6,596,015 B1 7/2003 Pitt et al.  
6,641,596 B1 11/2003 Lizardi  
6,641,597 B2 11/2003 Burkhart et al.  
6,652,563 B2 11/2003 Dreyfuss  
6,660,023 B2 12/2003 McDevitt et al.  
6,689,154 B2 2/2004 Bartlett  
6,716,234 B2 4/2004 Grafton et al.  
6,767,037 B2 7/2004 Wenstrom, Jr.  
6,818,010 B2 11/2004 Eichhorn et al.  
6,887,259 B2 5/2005 Lizardi  
6,923,824 B2 8/2005 Morgan et al.  
6,994,719 B2 2/2006 Grafton  
7,029,490 B2 4/2006 Grafton et al.  
7,048,754 B2 5/2006 Martin et al.  
7,081,126 B2 7/2006 McDevitt et al.  
7,217,279 B2 5/2007 Reese  
7,226,469 B2 6/2007 Benavitz et al.  
7,235,090 B2 6/2007 Buckman et al.  
7,285,124 B2 10/2007 Foerster  
7,309,337 B2 12/2007 Colleran et al.  
7,338,502 B2 3/2008 Rosenblatt  
7,381,213 B2 6/2008 Lizardi  
7,390,332 B2 6/2008 Selvitelli et al.  
7,455,684 B2 11/2008 Gradel et al.  
7,582,105 B2 9/2009 Kolster  
7,601,165 B2 10/2009 Stone  
7,651,509 B2 1/2010 Bojarski et al.  
7,654,321 B2 2/2010 Zazovsky et al.  
7,658,750 B2 2/2010 Li  
7,658,751 B2 2/2010 Stone et al.  
7,682,374 B2 3/2010 Foerster et al.  
7,695,495 B2 4/2010 Dreyfuss

(56)

## References Cited

## U.S. PATENT DOCUMENTS

7,703,372	B1	4/2010	Shakespeare	2008/0009901	A1	1/2008	Redmond et al.
7,803,173	B2	9/2010	Burkhart et al.	2008/0009904	A1	1/2008	Bourque et al.
7,875,043	B1	1/2011	Ashby et al.	2008/0027446	A1	1/2008	Stone et al.
7,883,528	B2	2/2011	Grafton et al.	2008/0065114	A1	3/2008	Stone et al.
7,883,529	B2	2/2011	Sinnott et al.	2008/0077182	A1	3/2008	Geissler et al.
7,905,903	B2	3/2011	Stone et al.	2008/0091237	A1	4/2008	Schwartz et al.
7,905,904	B2	3/2011	Stone et al.	2008/0103528	A1	5/2008	Zirps et al.
7,959,650	B2	6/2011	Kaiser et al.	2008/0140092	A1	6/2008	Stone et al.
7,981,140	B2	7/2011	Burkhart	2008/0147063	A1	6/2008	Cauldwell et al.
8,012,171	B2	9/2011	Schmieding	2008/0188893	A1	8/2008	Selvitelli et al.
8,088,130	B2	1/2012	Kaiser et al.	2008/0195205	A1	8/2008	Schwartz
8,088,146	B2	1/2012	Wert et al.	2008/0208265	A1	8/2008	Frazier et al.
8,114,128	B2	2/2012	Cauldwell et al.	2008/0228265	A1	9/2008	Spence et al.
8,118,836	B2	2/2012	Denham et al.	2008/0255613	A1	10/2008	Kaiser et al.
8,137,382	B2	3/2012	Denham et al.	2008/0275469	A1	11/2008	Fanton et al.
8,231,653	B2	7/2012	Dreyfuss	2008/0312689	A1	12/2008	Denham et al.
8,231,654	B2	7/2012	Kaiser et al.	2009/0023984	A1	1/2009	Stokes et al.
8,419,769	B2	4/2013	Thal	2009/0036905	A1	2/2009	Schmieding
8,545,535	B2	10/2013	Hirotsuka et al.	2009/0054928	A1	2/2009	Denham et al.
8,608,758	B2	12/2013	Singhatat et al.	2009/0062850	A1	3/2009	Ken
8,790,369	B2	7/2014	Orphanos et al.	2009/0062854	A1	3/2009	Kaiser et al.
8,790,370	B2	7/2014	Spenciner et al.	2009/0082805	A1	3/2009	Kaiser et al.
8,814,905	B2	8/2014	Sengun et al.	2009/0082807	A1	3/2009	Miller et al.
8,821,543	B2	9/2014	Hernandez et al.	2009/0088798	A1	4/2009	Snyder et al.
8,821,544	B2	9/2014	Sengun et al.	2009/0099598	A1	4/2009	McDevitt et al.
8,821,545	B2	9/2014	Sengun	2009/0138042	A1	5/2009	Thal
8,894,684	B2	11/2014	Sengun	2009/0234387	A1	9/2009	Miller et al.
8,974,495	B2	3/2015	Hernandez et al.	2009/0281568	A1	11/2009	Cendan et al.
9,017,381	B2	4/2015	Kaiser et al.	2009/0281581	A1	11/2009	Berg
9,034,013	B2	5/2015	Sengun	2009/0287246	A1	11/2009	Cauldwell et al.
9,060,763	B2	6/2015	Sengun	2009/0306711	A1	12/2009	Stone et al.
9,060,764	B2	6/2015	Sengun	2009/0312776	A1	12/2009	Kaiser et al.
9,095,331	B2	8/2015	Hernandez et al.	2009/0312794	A1	12/2009	Nason et al.
9,179,908	B2	11/2015	Sengun	2009/0318958	A1	12/2009	Ochiai
9,192,373	B2	11/2015	Sengun	2010/0004683	A1	1/2010	Hoof et al.
9,198,653	B2	12/2015	Sengun et al.	2010/0016892	A1	1/2010	Kaiser et al.
9,271,716	B2	3/2016	Sengun	2010/0094425	A1	4/2010	Bentley et al.
9,345,468	B2	5/2016	Sengun et al.	2010/0162882	A1	7/2010	Shakespeare
9,345,567	B2	5/2016	Sengun	2010/0204730	A1	8/2010	Maiorino et al.
9,532,778	B2	1/2017	Sengun et al.	2010/0249809	A1	9/2010	Singhatat et al.
2002/0019649	A1	2/2002	Sikora et al.	2010/0249834	A1	9/2010	Dreyfuss
2002/0029066	A1	3/2002	Foerster	2010/0256677	A1	10/2010	Albertorio et al.
2003/0004545	A1	1/2003	Burkhart et al.	2010/0292732	A1	11/2010	Hirotsuka et al.
2003/0050667	A1	3/2003	Grafton et al.	2010/0292792	A1	11/2010	Stone et al.
2003/0120309	A1	6/2003	Colleran et al.	2011/0022083	A1	1/2011	Dimatteo et al.
2003/0130695	A1	7/2003	McDevitt et al.	2011/0022084	A1	1/2011	Sengun et al.
2003/0229362	A1	12/2003	Chan et al.	2011/0077667	A1	3/2011	Singhatat et al.
2004/0093031	A1	5/2004	Burkhart et al.	2011/0098727	A1	4/2011	Kaiser et al.
2004/0098050	A1	5/2004	Foerster et al.	2011/0152928	A1	6/2011	Colleran et al.
2004/0153074	A1	8/2004	Bojarski et al.	2011/0190815	A1	8/2011	Saliman
2004/0172062	A1	9/2004	Burkhart	2011/0208239	A1	8/2011	Stone et al.
2004/0236373	A1	11/2004	Anspach	2011/0208240	A1	8/2011	Stone et al.
2005/0033363	A1	2/2005	Bojarski et al.	2011/0213416	A1	9/2011	Kaiser
2005/0119696	A1	6/2005	Walters et al.	2011/0238111	A1	9/2011	Frank
2005/0137624	A1	6/2005	Fallman	2011/0264140	A1	10/2011	Lizardi et al.
2005/0187577	A1	8/2005	Selvitelli et al.	2011/0264141	A1	10/2011	Denham et al.
2005/0251208	A1	11/2005	Elmer et al.	2011/0270278	A1	11/2011	Overes et al.
2006/0106423	A1	5/2006	Weisel et al.	2012/0046693	A1	2/2012	Denham et al.
2006/0178680	A1	8/2006	Nelson et al.	2012/0053630	A1	3/2012	Denham et al.
2006/0178702	A1	8/2006	Pierce et al.	2012/0059417	A1	3/2012	Norton et al.
2006/0293710	A1	12/2006	Foerster et al.	2012/0101523	A1	4/2012	Wert et al.
2007/0027476	A1	2/2007	Harris et al.	2012/0101524	A1	4/2012	Bennett
2007/0032792	A1	2/2007	Collin et al.	2012/0130423	A1	5/2012	Sengun et al.
2007/0060922	A1	3/2007	Dreyfuss	2012/0130424	A1	5/2012	Sengun et al.
2007/0083236	A1	4/2007	Sikora et al.	2012/0150223	A1	6/2012	Manos et al.
2007/0135843	A1	6/2007	Burkhart	2012/0165864	A1	6/2012	Hernandez et al.
2007/0150003	A1	6/2007	Dreyfuss et al.	2012/0179199	A1	7/2012	Hernandez et al.
2007/0156148	A1	7/2007	Fanton et al.	2012/0253389	A1	10/2012	Sengun et al.
2007/0156149	A1	7/2007	Fanton et al.	2012/0253390	A1	10/2012	Sengun
2007/0156150	A1	7/2007	Fanton et al.	2012/0296375	A1	11/2012	Thal
2007/0156176	A1	7/2007	Fanton et al.	2013/0110165	A1	5/2013	Burkhart et al.
2007/0219557	A1	9/2007	Bourque et al.	2013/0158598	A1	6/2013	Lizardi
2007/0219558	A1	9/2007	Deusch	2013/0261664	A1	10/2013	Spenciner et al.
2007/0225719	A1	9/2007	Stone et al.	2013/0296895	A1	11/2013	Sengun
2007/0239209	A1	10/2007	Fallman	2013/0296896	A1	11/2013	Sengun
				2013/0296931	A1	11/2013	Sengun
				2013/0296934	A1	11/2013	Sengun
				2014/0081324	A1	3/2014	Sengun
				2014/0107701	A1	4/2014	Lizardi et al.

(56)

**References Cited**

## U.S. PATENT DOCUMENTS

2014/0188163	A1	7/2014	Sengun
2014/0188164	A1	7/2014	Sengun
2014/0277132	A1	9/2014	Sengun et al.
2014/0330312	A1	11/2014	Spenciner et al.
2014/0343606	A1	11/2014	Hernandez et al.
2014/0343607	A1	11/2014	Sengun et al.
2015/0012038	A1	1/2015	Sengun et al.
2015/0025572	A1	1/2015	Sengun
2015/0045832	A1	2/2015	Sengun
2015/0245832	A1	9/2015	Sengun
2015/0297214	A1	10/2015	Hernandez et al.
2015/0313587	A1	11/2015	Lizardi et al.
2016/0128687	A1	5/2016	Sengun
2016/0278761	A1	9/2016	Sengun et al.
2016/0296222	A1	10/2016	Sengun
2017/0000479	A1	1/2017	Sengun et al.

## FOREIGN PATENT DOCUMENTS

CN	2719234	Y	8/2005
CN	101252887	A	8/2008
CN	101442944	A	5/2009
CN	101961256	A	2/2011
CN	102113901	A	7/2011
EP	0 870 471	A1	10/1998
EP	1 199 035	A1	4/2002
EP	1 707 127	A1	10/2006
EP	2 277 457	A1	1/2011
EP	2 455 003	A2	5/2012
EP	2 572 650	A1	3/2013
JP	2000-512193	A	9/2000
WO	95/19139	A1	7/1995
WO	97/17901	A1	5/1997
WO	98/11825	A1	3/1998
WO	98/42261	A1	10/1998
WO	01/06933	A2	2/2001
WO	03/022161	A1	3/2003
WO	2007/005394	A1	1/2007
WO	2007/078281	A2	7/2007
WO	2007/109769	A1	9/2007

## OTHER PUBLICATIONS

Chinese Office Action for Application No. 201310163420.7, issued May 5, 2016 (21 pages).

[No Author Listed] Arthroscopic Knot Tying Manual 2005. DePuy Mitek. 27 pages.

[No Author Listed] Gryphon Brochure. DePuy Mitek. 2 pages (undated).

[No Author Listed] Versalok Anchor. Brochure. DePuy Mitek, a Johnson & Johnson company, 92 pages, 2007.

Allcock, The Encyclopedia of Polymer Science, vol. 13, pp. 31-41, Wiley Intersciences, John Wiley & Sons, 1988.

Cohn et al., Biodegradable PEO/PLA block copolymers. J Biomed Mater Res. Nov. 1998;22(11):993-1009.

Cohn et al., Polym Preprint. 1989;30(1):498.

Dahl et al., Biomechanical characteristics of 9 arthroscopic knots. Arthroscopy. Jun. 2010;26(6):813-8.

EP Search Report for Application No. 11190157.5 issued Feb. 27, 2012. (8 pages).

Extended European Search Report for Application No. 11190157.5 issued Jul. 6, 2012. (10 pages).

EP Search Report for Application No. 11190159.1 issued Feb. 21, 2012. (8 pages).

Extended European Search Report for Application No. 11190159.1 issued Jul. 6, 2012. (11 pages).

Extended European Search Report for Application No. 11195100.0 issued Oct. 17, 2012. (7 pages).

Extended European Search Report for Application No. 13166905.3 issued Aug. 13, 2013 (9 Pages).

Extended European Search Report for Application No. 13166907.9, issued Aug. 1, 2013 (6 pages).

Extended European Search Report for Application No. 13166908.7, issued Aug. 23, 2013 (8 pages).

Extended European Search Report for Application No. 13185425.9 issued Dec. 16, 2013 (9 Pages).

Extended European Search Report for Application No. 13199724.9 issued Apr. 4, 2014 (6 Pages).

Heller, Handbook of Biodegradable Polymers, edited by Domb, et al., Hardwood Academic Press, pp. 99-118 (1997).

International Search Report for Application No. PCT/US2011/067119, mailed Jun. 4, 2012. (6 pages).

Kemnitzner et al., Handbook of biodegradable Polymers. Eds. Domb et al. Hardwood Acad. Press. 1997;251-72.

Vandorpe et al., Handbook of Biodegradable Polymers, edited by Domb, et al., Hardwood Acad. Press, pp. 161-182 (1997).

Chinese Office Action for Application No. 201310163700.8 issued Jun. 3, 2016 (14 pages).

Chinese Office Action for Application No. 201310429109.2 issued Oct. 24, 2016 (13 pages).

Chinese Office Action for Application No. 201310741440.8, issued Jan. 26, 2017 (12 pages).

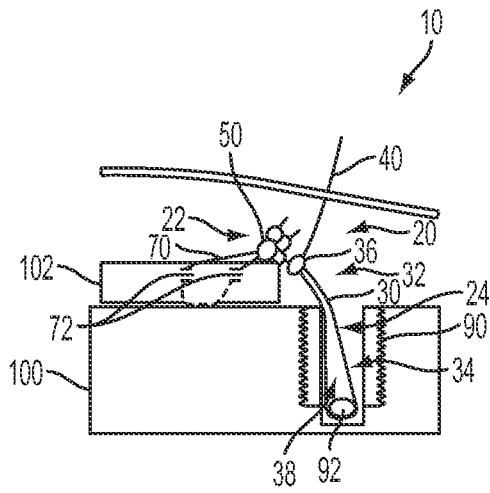

FIG. 1

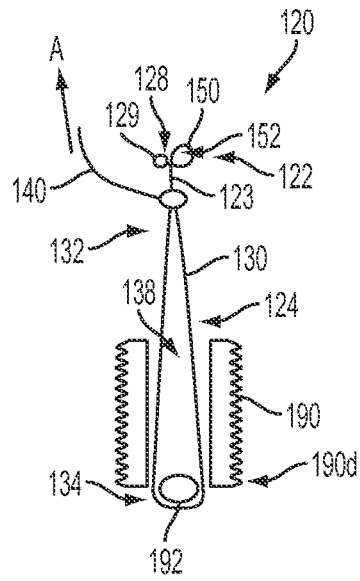

FIG. 2

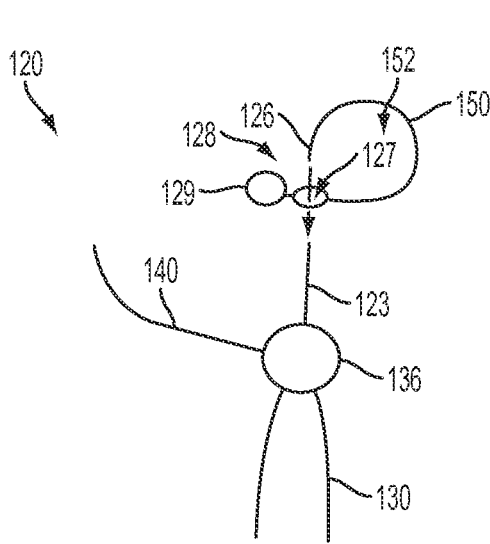

FIG. 3

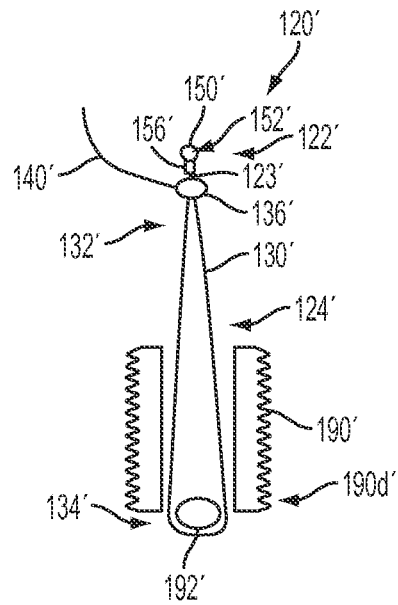
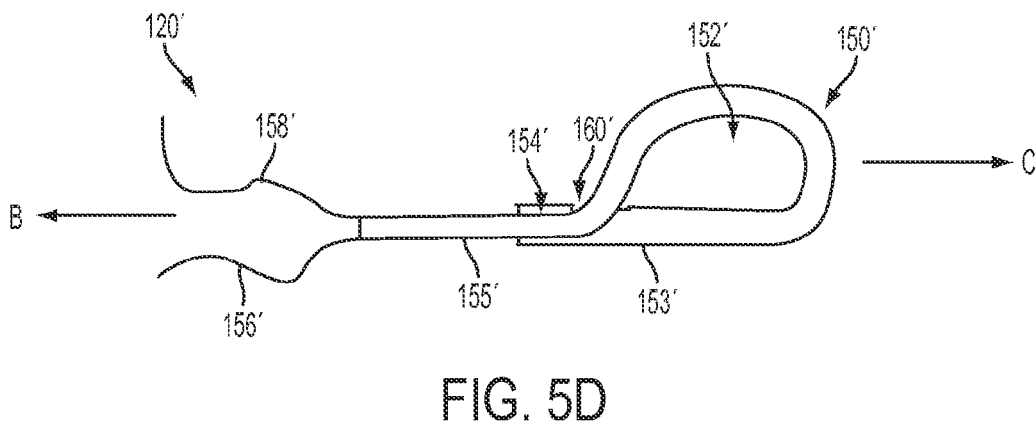
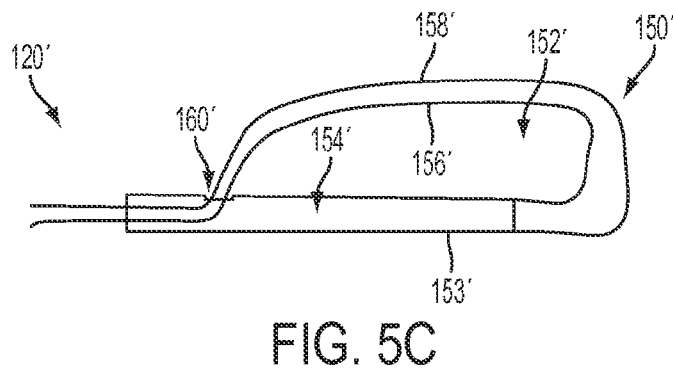
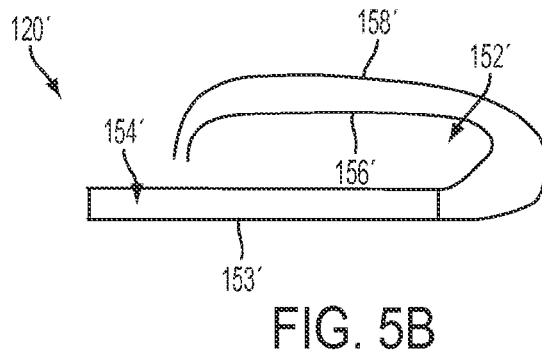
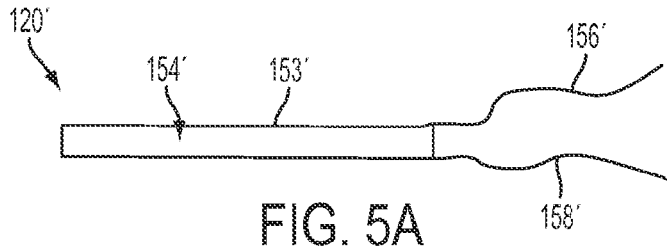

FIG. 4



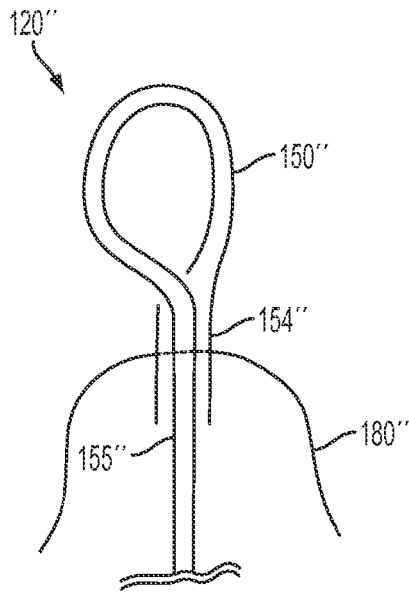

FIG. 6

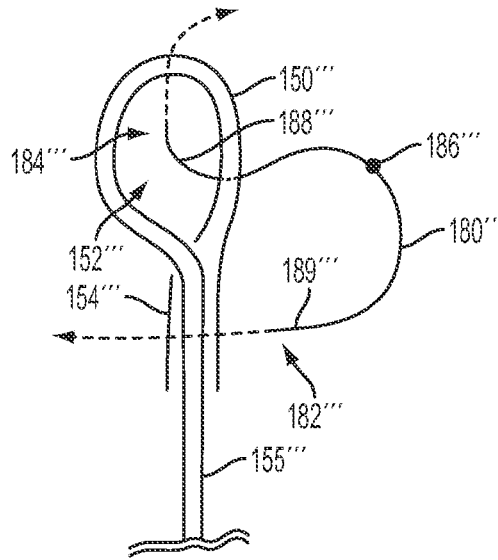

FIG. 7A

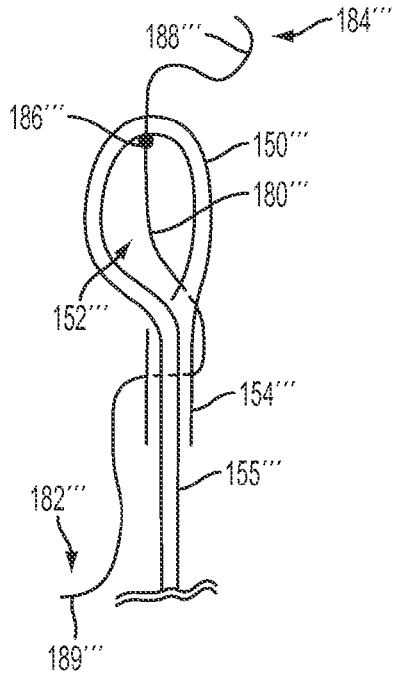

FIG. 7B

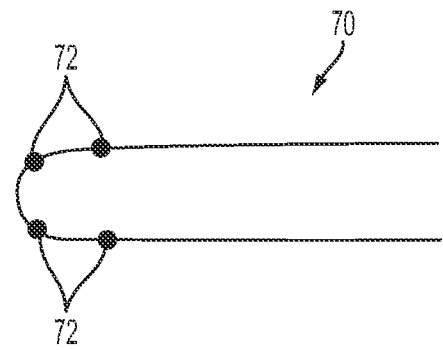

FIG. 8

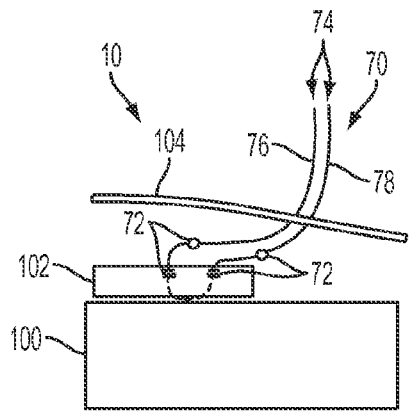

FIG. 9A

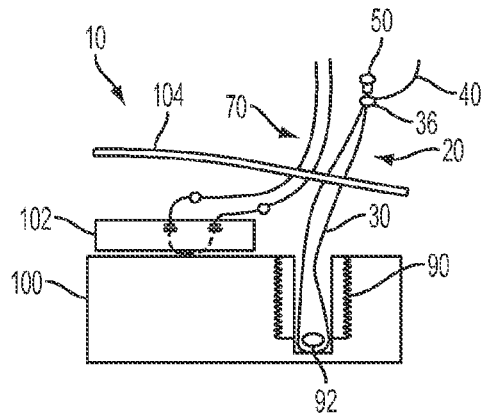

FIG. 9B

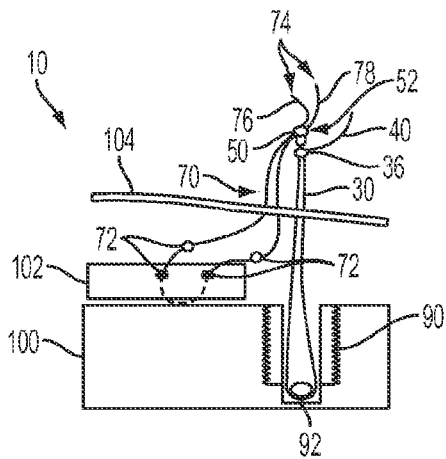

FIG. 9C

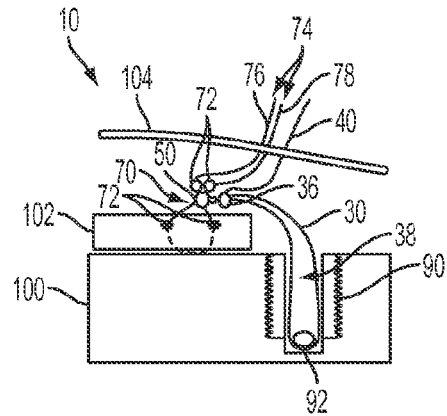

FIG. 9D

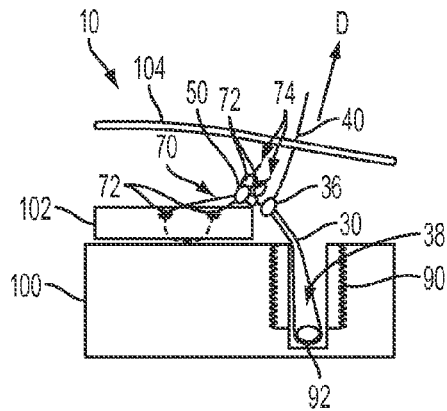

FIG. 9E



1

**SYSTEMS, DEVICES, AND METHODS FOR  
SECURING TISSUE USING A SUTURE  
HAVING ONE OR MORE PROTRUSIONS**

CROSS REFERENCE TO RELATED  
APPLICATIONS

The present application is a continuation of U.S. patent application Ser. No. 14/522,562, filed Oct. 23, 2014, and entitled "SYSTEMS, DEVICES, AND METHODS FOR SECURING TISSUE USING A SUTURE HAVING ONE OR MORE PROTRUSIONS," which itself is a divisional of U.S. Pat. No. 8,894,684, filed May 7, 2012, issued Nov. 25, 2014, and entitled "SYSTEMS, DEVICES, AND METHODS FOR SECURING TISSUE USING A SUTURE HAVING ONE OR MORE PROTRUSIONS," each of which is hereby incorporated by reference in its entirety.

FIELD

The present disclosure relates to systems, devices, and methods for securing soft tissue to bone, and more particularly relates to securing soft tissue using a suture having one or more protrusions formed thereon while minimizing or eliminating the tying of knots to tension and secure the tissue.

BACKGROUND

A common injury, especially among athletes and people of advancing age, is the complete or partial detachment of tendons, ligaments, or other soft tissues from bone. Tissue detachment may occur during a fall, by overexertion, or for a variety of other reasons. Surgical intervention is often needed, particularly when tissue is completely detached from its associated bone. Currently available devices for tissue attachment include screws, staples, suture anchors, and tacks. Currently available devices for patients of advancing age can be particularly insufficient due to soft and weak bones leading to inadequate suture-to-anchor fixation.

Arthroscopic knot tying is commonly practiced in shoulder rotator cuff and instability procedures. Typically, an anchor loaded with suture is first attached to bone. The suture is normally slidably attached to the anchor through an eyelet or around a post, such that a single length of suture has two free limbs. One limb of the suture is passed through soft tissue to be repaired such as a tendon or labrum. The two ends of the suture are then tied to each other, thereby capturing the soft tissue in a loop with the anchor. Upon tightening the loop, the soft tissue is approximated to the bone via the anchor.

Surgeons typically tie the suture ends using a surgical sliding knot such as the Tennessee Slider or Duncan Loop. After advancing the knot distally to tighten the loop, a number of additional half hitches or other knots are tied in an effort to secure the new location of the sliding knot. The additional knots are needed because a conventional sliding knot used in current repair constructs does not provide the necessary protection against loosening or slippage, especially when tension is placed primarily on the limbs of the loop. The generally accepted practice is to follow the sliding knot with at least three reversed half hitches on alternating posts of the suture.

Before one or more half hitches or other knots can be added to the sliding knot, however, there exists a potential for the sliding knot to slip, that is, for the loop to enlarge as the tissue places tension on the loop. This has been referred

2

to as "loop security" and can reportedly occur even in the hands of very experienced surgeons. Sometimes, even fully-tied knots may slip. In addition to this "loop security" problem, conventional knots typically have an overall size that can be obstructive or intrusive, especially in tight joints, which may damage cartilage or other tissue by abrasion with the knot.

Suture anchor systems with sliding and locking knots for repairing torn or damaged tissue include U.S. Pat. No. 6,767,037 by Wenstrom, Jr. Other suture anchor systems suited especially for meniscal repair are disclosed in U.S. Pat. No. 7,390,332 by Selvitelli et al. and are utilized in the OmniSpan™ meniscal repair system commercially available from DePuy Mitek Inc., 325 Paramount Drive, Rayn- ham, Mass. 02767. Screw-type anchors normally require anchor attachment before operating sutures, which can lead to challenges related to the connection between the suture and the tissue.

There are a number of suture implant systems which proclaim to be "knotless," that is, to not require a surgeon to tie a knot during surgery. Many such systems control tension on tissue by the depth to which an anchor is driven into bone. U.S. Pat. Nos. 5,782,864 and 7,381,213 by Lizardi disclose certain types of suture anchors that capture a fixed-length loop of suture. Adjustable loop knotless anchor assemblies utilizing an anchor element inserted into a sleeve are described by Thal in U.S. Pat. Nos. 5,569,306 and 6,045,574 and in U.S. Patent Application Publication No. 2009/0138042. Other systems having clamps or other locking mechanisms include U.S. Pat. No. 5,702,397 by Goble et al. and U.S. Patent Application Publication No. 2008/0091237 by Schwartz et al. Present, so-called "knotless" designs, however, generally suffer from inadequate suture-to-anchor fixation and/or inadequate anchor-to-bone fixation, among other deficiencies.

It is therefore desirable to provide systems, devices, and methods for use in soft tissue repair that are robust, strong, and improve "loop security," yet minimize or eliminate the number and size of knots to be tied by a surgeon, particularly during arthroscopic repair procedures.

SUMMARY

Systems, devices, and methods are generally provided for securing soft tissue to bone. In one exemplary embodiment a surgical repair construct includes an anchor, a filament having a collapsible snare formed on one end thereof and a collapsible loop at a second end thereof, and a suture having a plurality of stationary protrusions formed thereon in a spaced-apart arrangement. The anchor can include a filament engagement feature and can be capable of being fixated in bone. The filament and the suture are both capable of being passed through soft tissue to be repaired. An opening of the filament's snare can be configured to receive the suture such that the snare is slidable with respect to the suture and collapsible around the suture. The filament's collapsible loop can be coupled to the anchor's filament engagement feature, and the loop can include a sliding knot with a tensioning limb extending therefrom. The tensioning limb can be effective to collapse the collapsible loop independent of the snare. Further, the collapsible loop can be capable of being tightened incrementally to secure the soft tissue to bone.

The snare can have a variety of configurations and can be made in a number of different ways. In some embodiments, the snare can be configured by passing a terminal end of the filament through an adjacent portion of the filament. The

3

terminal end can include a protrusion that maintains the terminal end within the portion of the filament through which it is disposed. In some other embodiments, the snare can be configured by a second sliding knot that is effective to collapse the snare. In still other embodiments, the snare can include a coaxial sliding neck that is effective to collapse the snare. Further, a flexible member can be removably placed in a portion of the snare to prevent unintentional collapse of the snare, and when the snare includes a coaxial sliding neck, the flexible member can be removably disposed therethrough to immobilize the coaxial sliding neck. The filament can be a cannulated surgical filament or a braided suture filament. Further, in embodiments that include a flexible member, the flexible member can be formed of a second filament. A thickness of the second filament can be in the range of about 25 gauge to about 40 gauge, while a thickness of either or both of the filament that forms the collapsible loop and the collapsible snare can be in the range of about 20 gauge to about 34 gauge. The diameter of the protrusions of the suture can be in the range of about 0.5 millimeters to about 2 millimeters.

In one exemplary embodiment of a surgical repair method, the method includes passing a first end of a suture having formed thereon a plurality of stationary protrusions through and/or into tissue. The first end of the suture can be passed through the tissue such that first and second limbs of the suture extend from the first side of the tissue. The suture can be arranged in the tissue such that at least one of the protrusions is disposed adjacent to at least one of the first and second sides of the tissue. In one embodiment at least one protrusion is disposed adjacent to the first side of the tissue. The method can also include inserting an anchor into bone in proximity to the detached soft tissue. The anchor can have a filament engagement feature to which a filament is attached, and the filament can have a collapsible snare formed on one end and a collapsible loop at its second end, the collapsible loop being coupled to the filament engagement feature. The collapsible loop can include a sliding knot with a tensioning limb that extends therefrom, and the tensioning limb can be effective to collapse the collapsible loop independent of the snare. The method can further include inserting the first and second limbs of the suture through an opening formed in the snare, sliding the snare distally towards the tissue and distally past at least one protrusion disposed on the first side of the tissue, collapsing the snare around the first and second limbs of the suture, and pulling the snare towards the anchor by shortening the collapsible loop and thus drawing the tissue into proximity with the bone.

In some embodiments the step of pulling the snare towards the anchor by shortening the collapsible loop can include tensioning the tensioning limb. In such embodiments the snare can be advanced in an incremental fashion without slackening of the filament. The suture can include at least four protrusions. In some embodiments the snare can be positioned between at least one protrusion and the tissue, while in some other embodiments the snare can be positioned between at least two protrusions and the tissue. Optionally, a flexible member can be disposed in a portion of the snare to prevent unintentional collapse thereof. In such embodiments the flexible member can be removed from the snare prior to collapsing the snare. The methods provided for herein can be performed without tying a knot.

#### BRIEF DESCRIPTION OF DRAWINGS

This invention will be more fully understood from the following detailed description taken in conjunction with the accompanying drawings, in which:

4

FIG. 1 is schematic view of one exemplary embodiment of a surgical repair construct disposed at a surgical site;

FIG. 2 is a schematic view of one exemplary embodiment of a filament coupled to an anchor for use as part of a surgical repair construct;

FIG. 3 is a close-up view of a portion of the filament of FIG. 2, illustrating the formation of a snare using the filament;

FIG. 4 is a schematic view of a filament coupled to an anchor from the surgical repair construct of FIG. 1;

FIGS. 5A-5D are sequential views of one exemplary embodiment for forming a snare from a filament in which the snare has a coaxial sliding neck;

FIG. 6 is a schematic view of one exemplary embodiment of a snare formed from a filament and a flexible member in which the snare has a coaxial sliding neck and the flexible member is disposed through the snare;

FIG. 7A is a schematic view of another exemplary embodiment of a snare formed from a filament and a flexible member in which the snare has a coaxial sliding neck, this view illustrating how the flexible member can be disposed through the neck and the snare;

FIG. 7B is a schematic view of the snare and flexible member of FIG. 7A, illustrating the flexible member disposed through the neck and the snare;

FIG. 8 is a schematic view of a suture from the surgical repair construct of FIG. 1; and

FIGS. 9A-9E are sequential views of one exemplary embodiment for using the surgical repair construct of FIG. 1 to secure tissue to bone.

#### DETAILED DESCRIPTION

Certain exemplary embodiments will now be described to provide an overall understanding of the principles of the structure, function, manufacture, and use of the devices and methods disclosed herein. One or more examples of these embodiments are illustrated in the accompanying drawings. Those skilled in the art will understand that the devices and methods specifically described herein and illustrated in the accompanying drawings are non-limiting exemplary embodiments and that the scope of the present invention is defined solely by the claims. The features illustrated or described in connection with one exemplary embodiment may be combined with the features of other embodiments. Such modifications and variations are intended to be included within the scope of the present invention. Further, in the present disclosure, like-numbered components of the embodiments generally have similar features, and thus within a particular embodiment each feature of each like-numbered component is not necessarily fully elaborated upon. Additionally, to the extent that linear or circular dimensions are used in the description of the disclosed systems, devices, and methods, such dimensions are not intended to limit the types of shapes that can be used in conjunction with such systems, devices, and methods. A person skilled in the art will recognize that an equivalent to such linear and circular dimensions can easily be determined for any geometric shape. Sizes and shapes of the systems and devices, and the components thereof, can depend at least on the anatomy of the subject in which the systems and devices will be used, the size and shape of components with which the systems and devices will be used, and the methods and procedures in which the systems and devices will be used.

The figures provided herein are not necessarily to scale. Still further, to the extent arrows are used to describe a

5

direction a component can be tensioned or pulled, these arrows are illustrative and in no way limit the direction the respective component can be moved. A person skilled in the art will recognize other ways and directions for creating the desired result. Additionally, a number of terms may be used throughout the disclosure interchangeably but will be understood by a person skilled in the art.

Systems, devices, and methods for soft tissue repair are generally provided and they generally involve the use of surgical filaments and sutures that are configured in a variety of manners to minimize and/or eliminate the tying of knots during a surgical procedure. The systems and devices described herein provide superior strength for use in a number of different surgical procedures, such as rotator cuff and instability repair procedures and other types of tendon and tissue repair procedures. The systems and devices provided herein also allow for both improved and new procedures for soft tissue repair. For example, the systems and devices provided herein can be used to advance tissue towards bone in an incremental fashion without the construct backlashing. Reducing and/or eliminating backlashing during advancement can prevent the size of the collapsible loop from increasing and prevent the tissue from moving away from the bone and/or not being held tightly in place with respect to the bone due to backlashing. Additionally, the systems and devices allow a surgeon to secure a location of the tissue without tying a knot during the procedure.

As shown by one exemplary embodiment of a surgical repair construct **10** in FIG. **1**, the constructs of the present disclosure generally include a filament **20** that forms a snare **50** at a first end **22** thereof and a collapsible loop **30** at a second end **24** thereof, a suture **70** having one or more stationary protrusions **72** formed therein, and an anchor **90** coupled to the collapsible loop **30**, for instance at an engagement feature **92** of the anchor **90**. In the illustrated embodiment, the anchor **90** is disposed in bone **100**, the suture **70** is passed through soft tissue, for example tendon **102**, and the snare **50** is slidable with respect to the suture **70** and collapsed around a portion of the suture **70** to couple the bone **100** and tendon **102** via the surgical repair construct **10**. As will be described in greater detail below, the snare **50** can begin outside of the body and be moved distally (e.g., towards the bone **100**) such that it is distal of at least one of the protrusions **72**. The snare **50** can subsequently be collapsed such that the protrusions **72** prevent the snare **50** from backlashing in a proximal direction (e.g., away from the bone **100**), which would allow the tissue to move away from the bone. The filament **20** can further include a sliding knot **36** at a first end **32** of the loop **30**, which can be moved distally towards a second end **34** of the loop **30** to collapse a size of an opening **38** formed by the loop **30**, thereby applying a force to draw the tendon **102** towards the bone **100**. A collapsible tail or tensioning limb **40** can extend from the sliding knot **36** and can be operable to move the sliding knot **36** towards the second end **34** in a ratchet-like or incremental manner to secure the tendon **102** to the bone **100**. Movement, of the snare **50**, including collapsing the snare **50**, and movement of the collapsible loop **30**, including by tensioning the tensioning limb **40**, can be independent of each other.

Filaments for use in a surgical repair construct can have a variety of configurations, some of which are described in greater detail below. Generally filaments have a portion for grasping a separate suture coupled to tissue, illustrated herein as a snare, and a portion, illustrated herein as a collapsible loop, that is coupled to bone and to which tension can be applied to draw the tissue towards bone. In operation,

6

grasping the separate suture couples the tissue to the filament and collapsing the loop towards the bone draws the tissue towards the bone.

FIG. **2** provides one exemplary embodiment of a filament **120** for use as part of a surgical repair construct. A first end **122** of the filament **120** can include a snare **150** that is configured to collapse under tension, a second end **124** of the filament **120** can include a collapsible loop **130** that is configured to collapse under tension, independent of the snare **150**, and a neck **123** can extend between the first and second ends **122**, **124**. The filament **120** having both a snare **150** and a collapsible loop **130** can be referred to as a snare assembly.

The snare **150** can be formed in a variety of ways known to those skilled in the art, some of which are discussed in greater detail below. In the illustrated embodiment the snare **150** is formed by passing a portion of the filament **120** through itself. Further, a protrusion **129** can be formed at a terminal end **128** of the filament **120**, proximate to the snare **150**, to prevent pull-through and to resist fraying, particularly if the filament **120** is a braided filament. The protrusion **129** can be pre-formed, or it can be formed by a surgeon, for instance by tying a half-hitch or other simple knot.

FIG. **3** illustrates one of the many ways the snare **150** can be formed. As shown, a leading end **126** of the filament **120** can be passed through an opening **127** of the filament **120** to form a collapsible opening **152** of the snare **150**. The opening **127** can be pre-formed and collapsible, or alternatively, it can be part of the construct of the filament **120**, such as an opening due to the filament **120** being braided. The leading end **126** can be used to form the other portions of the filament **120**, including the collapsible loop **130**, a sliding knot **136**, and a tensioning limb **140**, which are described in greater detail below, for instance by forming the loop **130** and the sliding knot **136** on the tensioning limb **140**. In this arrangement, any tension applied on the neck **123**, such as by pulling the tensioning limb **140**, not only collapses the snare **150** to strangulate objects passing therethrough, but also binds the portion of the filament **120** passing through the opening **127** upon itself. In other arrangements, a half-hitch or other simple knot can be tied adjacent to the opening, and the filament **120** can be looped through that simple knot.

The loop **130** can likewise be formed in a variety of ways known to those skilled in the art, some of which are discussed in greater detail below. In the illustrated embodiment of FIG. **2**, the loop **130** has first and second ends **132**, **134**, with a sliding knot **136** formed at the first end **132**. As shown, the second end **134** can be slidably coupled to an anchor **190**, for instance at an engagement feature **192** thereof, such as a saddle or post. While in the illustrated embodiment the engagement feature **192** is located at a distal end **190d** of the anchor **190**, it can be located in any part of the anchor **190** and it allows the filament **120** to be slidably engaged with the anchor **190**.

The collapsible loop **130** can be expanded and collapsed as desired by the sliding knot **136**. Accordingly, when the loop **130** is coupled to tissue, for instance by having a suture disposed through the snare **150** of the filament **120** that forms the loop **130**, collapsing the loop **130** creates a force that draws the tissue towards a desired location. As shown in FIG. **2**, as the sliding knot **136** is moved towards the second end **134**, the loop **130** collapses, and as the knot **136** is moved away from the second end **134**, the size of an opening **138** of the loop **130** increases. The sliding knot **136** can be formed in a variety of ways using a variety of techniques well known to those skilled in the art. Non-

limiting examples of the types of knots that can be used as the loop's sliding knot include a Buntline Hitch, a Tennessee Slider, a Duncan Loop, a Hangman's Noose, and a loop having a coaxial sliding neck. The type of knot selected may affect the manner in which the loop 130 can be collapsed, and a person having skill in the art will recognize how to collapse the loop based on the type of knot used.

As shown in FIG. 2, the loop 130 can also have a collapsible tail or tensioning limb 140 that extends from the sliding knot 136. The tensioning limb 140 can be a terminal end of a limb of the filament 120 used to form the sliding knot 136 that completes the collapsible loop 130. The tensioning limb 140 can be operable to tension and collapse the loop 130 by moving the sliding knot 136 towards the loop second end 134. More particularly, applying tension to the tensioning limb 140 in approximately a direction A can cause the knot 136 to slide distally towards the second end 134. As a result, the sliding knot 136 can move in a ratchet-like or incremental fashion such that the knot 136 moves towards the second end 134 with little or no back-lashing, which in turn minimizes or prevents the opening 138 of the collapsible loop 130 from increasing in size. When tension is not applied, the location of the sliding knot 136 remains substantially fixed, and further tensioning of the knot 136 until either the tension is released or an obstruction precludes further distal movement of the knot 136. The self-locking capabilities provided by this sliding knot 136 that results from the overall formation of a surgical repair construct including the filament 120 are beneficial at least because of the ability to incrementally advance the knot 136 with minimal or no backlashing. Still further, in some embodiments a second, stationary tail or tail can also be formed and can be used, for example, to assist in threading the filament through tissue, providing additional strength to the repair, and/or performing various surgical procedures, such as double row procedures

With reference to FIG. 3, an example of steps for manufacturing the snare assembly formed by the filament 120 is as follows. The protrusion 129 can be formed at the terminal end 128 by tying a knot and a tail of a terminal end thereof can be trimmed. The leading end 126 can be looped and passed through itself at the opening 127, in close proximity to the protrusion 129, to form the opening 152 in the snare 150. Alternatively, a second half-hitch can be tied in close proximity to the protrusion 129 and the leading end 126 can be passed through the second half-hitch to form the opening 152 in the snare 150. A flexible member, such as a filament or suture (discussed in greater detail below with respect to FIGS. 6, 7A, and 7B), or other objects, including but not limited to thin mandrel or pin, can be placed through the snare 150 to maintain patency. The sliding knot 136, such as a Buntline Hitch, can be tied in close proximity to the snare 150 and the filament 120 can be placed in sliding engagement with an engagement feature of an anchor. The sliding knot 136 can be subsequently dressed or finalized as desired, including in manners described herein.

FIG. 4 provides another exemplary embodiment of a filament 120' for use as part of a surgical repair construct. Similar to the filament 120, a first end 122' of the filament 120' can include a snare 150' having an opening 152' that is configured to collapse under tension, a second end 124' of the filament 120' can include a collapsible loop 130' that is configured to collapse under tension, independent of the snare 150', and a neck 123' can extend between the first and

second ends 122', 124'. The filament 120' having both a snare 150' and a collapsible loop 130' can be referred to as a snare assembly.

The snare 150' can be formed in a variety of ways known to those skilled in the art, some of which are discussed in greater detail below. In the illustrated embodiment the snare 150' is formed by way of a sliding knot 156', such as, by way of non-limiting examples, a Buntline Hitch, a Tennessee Slider, a Duncan Loop, a Hangman's Noose, and a loop having a coaxial sliding neck. Although the type of sliding knot will affect the relative movement of the knot 156' and the filament 120' with respect to the direction either is moved to expand or collapse the snare 150', as described herein, unless otherwise designated, a knot used to form a snare is movable away from the second end 124' of the filament 120', i.e., away from the collapsible loop 130', to collapse the snare 150' and towards the second end 124', i.e., towards the collapsible loop 130', to increase a size of the snare 150'. A person skilled in the art would be able to adapt the teachings herein based on the type of sliding knot used in conjunction with the snare 150'.

FIGS. 5A-5D illustrate one of the many ways the snare 150' can be formed. As shown, the snare 150' is formed from a bifurcated suture filament having a tubular portion 153' with a core removed therefrom to form a cannulated portion 154' and first and second terminal limbs 156', 158'. As shown in FIG. 5B, the terminal limbs 156', 158' can be curled back towards the tubular portion 153' to form a loop having an opening 152' that defines the snare 150'. As shown in FIG. 5C, a bore 160' can be formed on a side of the tubular portion 153' and the terminal limbs 156', 158' can be placed into the cannulated tubular portion 154' through the bore 160'. Ends of the terminal limbs 156', 158' can be fed through the cannulated portion 154', and as shown in FIG. 5D, the terminal limbs 156', 158' can be pulled distally (direction B in FIG. 5D) through the tubular portion 153' such that the tubular portion 153' is fed through itself and a coaxial sliding neck 155' that can slide with respect to the tubular portion 153' of the filament is formed. Accordingly, the snare 150' can be collapsed by tensioning the limbs 156', 158' and/or coaxial sliding neck 155' in approximately a first direction B, and the snare 150' can be expanded by applying a force to the snare 150' in approximately a second, opposite direction C, which pulls the limbs 156', 158' and the coaxial sliding neck 155' towards the snare 150'. Passing the filament through itself to form a coaxial sliding neck allows the filament to have a low profile that minimizes the amount of space the construct consumes in the body and that minimizes and/or eliminates trauma associated with passing the filament through tissue.

The loop 130' can likewise be formed in a variety of ways known to those skilled in the art, some of which are discussed in greater detail below. In the illustrated embodiment of FIG. 4, the loop 130' has first and second ends 132', 134' with a sliding knot 136' formed at the first end 132'. As shown, the second end 134' can be slidably coupled to an anchor 190', for instance at an engagement feature 192' thereof, such as a saddle or post. While in the illustrated embodiment the engagement feature 192' is located at a distal end 190a' of the anchor 190', it can be located in any part of the anchor 190' and allows the filament 120' to be slidably engaged with the anchor 190'.

The collapsible loop 130' can be expanded and collapsed as desired by the sliding knot 136' in a manner similar to as described with respect to the sliding knot 136 of the loop 130. Further, as shown in FIG. 4, the loop 130' can include a collapsible tail or tensioning limb 140' that extends from

the sliding knot **136'** and can operate in a manner similar to as described with respect to the tensioning limb **140**. Thus, the loop **130'** of the filament **120'** can move in a ratchet-like or incremental fashion such that the knot **136'** moves towards the second end **134'** with little or no backslashing, which in turn minimizes or prevents the opening of the collapsible loop **130'** from increasing in size. Still further, in some embodiments a second, stationary tail or tail can also be formed and used in a manner similar to as described with respect to the filament **120**.

The filaments **120**, **120'** can be any suitable suture material such as a cannulated filament, a braided filament, and a mono filament. The type, size, and strength of the filament can depend, at least in part, on the other materials of the system, including the material(s) of any suture coupled thereto, any obstructions through which the filament may pass, and the type of procedure in which it is used. In one exemplary embodiment the filament is formed from a #0 filament (about 26 gauge to about 27 gauge), such as an Orthocord™ filament that is commercially available from DePuy Mitek, Inc or Ethibond™ filament available from Ethicon, Inc. Generally the filament is relatively thin to minimize any trauma to tissue through which it passes. In some embodiments the filament can have a size between about a #4 filament (about 21 gauge to about 22 gauge) and about a #4-0 filament (about 32 gauge to about 34 gauge). The Orthocord™ #2 filament can be useful because it has a braided configuration, which allows other components, including the filament itself and flexible members as discussed below, to pass through subcomponents of the braid without causing damage to the filament. Filaments configured to allow for a cannulated configuration, such as by removing a core therefrom or having a pre-formed cannulated configuration, can also be used. Orthocord™ suture is approximately fifty-five to sixty-five percent PDS™ polydioxanone, which is bioabsorbable, and the remaining thirty-five to forty-five percent ultra high molecular weight polyethylene, while Ethibond™ suture is primarily high strength polyester. The amount and type of bioabsorbable material, if any, utilized in the filaments of the present disclosure is primarily a matter of surgeon preference for the particular surgical procedure to be performed.

A length of the filament can be in the range of about 2 centimeters to about 60 centimeters, and in one embodiment it can be about 40 centimeters. Still further, a diameter of the sliding knot of the loop will depend, at least in part, on the size of the filament used to form it, the type of sliding knot that it is, and the type of procedure with which it will be used. In one exemplary embodiment a diameter of the sliding knot of the loop can be in the range of about 0.5 millimeters to about 2 millimeters, and in one embodiment it can be about 1 millimeter. Likewise, if the snare is formed from a sliding knot, its diameter will also depend, at least in part, on the size of the filament used to form it, the type of sliding knot that it is, and the type of procedure with which it will be used.

Although in the embodiments described above the snare and collapsible loop are formed from the same filament, in other embodiments each component can be formed from a separate filament. Exemplary systems, devices, and methods related to such configurations involving the formation of snares and loops from a single filament or more than one filament are described at least in U.S. patent application Ser. No. 13/218,810 filed Aug. 26, 2011, and entitled "SURGICAL FILAMENT SNARE ASSEMBLIES," and in U.S. patent application Ser. No. 13/465,288 filed concurrently herewith, and entitled "Systems, Devices, and Methods for

Securing Tissue", the content of each which is incorporated by reference herein in its entirety.

Because the snare of the filament can both expand and contract, a flexible member, such as a suture pin, can be removably disposed across the neck to prevent unintentional movement of the snare. One exemplary embodiment of a flexible member **180''** associated with a coaxially sliding neck **155''** of a snare **150''** of a filament **120''** is shown in FIG. 6. As illustrated, the flexible member **180''** can extend across the filament **120''** to immobilize the coaxially sliding neck **155''** with respect to a portion **154''** of the filament **150''** through which it is passed. When the surgeon desires to collapse the snare, the flexible member **180''** can be removed. The use of a flexible member of the type described herein to prevent unintentional collapse of the snare in tissue repair procedures is advantageous as it can prevent unintentional collapse of the snare during the procedures, including in instances in which the snare is passed through obstructions, such as tissue.

In another embodiment, shown in FIGS. 7A and 7B, a flexible member **180'''** can immobilize a snare **150'''** of a filament and serve as a suture shuttle to guide the filament through obstructions, such as tissue, during the course of a procedure. As shown in FIG. 7A, a first end **182'''** of the flexible member **180'''** can be passed across the filament, including a cannulated portion **154'''** and a coaxially sliding neck **155'''** of the filament, so that a first portion of the flexible member **180'''** is disposed through the coaxially sliding neck **155'''**, while a second end **184'''** of the flexible member **180'''** is passed through and disposed in the snare **150'''**. A protrusion **186'''**, for instance a stationary knot that can be pre-formed or formed or modified during a procedure, can be disposed on the flexible member **180'''** at a location between the first and second ends **182'''**, **184'''**. The protrusion **186'''** can serve to maintain the flexible member **180'''** in a coupled arrangement with the filament, and as shown in FIG. 7B, the protrusion **186'''** can be disposed within the opening or loop **152'''** formed by the snare **150'''**, abutting a surface of the snare, with a terminal portion **188'''** extending through and beyond the loop **152'''** for use as a shuttle. Optionally, a needle or similar tool or device can be coupled to the terminal portion **188'''** to assist in threading the filament **120'''** through tissue.

Other configurations in which a flexible member is used as both a suture pin and a suture shuttle are also possible, depending, at least in part, on the configuration of the filament and obstructions through which the filament will be passed, without departing from the spirit of the present disclosure. For example, the flexible member **180'''** can be disposed through another portion of the coaxially sliding neck **155'''** or a different portion of the snare **150'''**. One benefit of using a flexible member for both maintaining a snare shape and shuttling the filament is that it can improve filament management by limiting the number of filaments used in a procedure. Further, such a construction allows for a single action to remove both the pin and the shuttle from the filament, such as by grabbing the flexible member **180'''** between the stationary knot and the coaxially sliding neck **155'''** to decouple the flexible member **180'''** from the filament. In still other embodiments a flexible member can be used primarily for the purpose of shuttling the filament and/or one flexible member can be used as a suture pin and a second flexible member can be used as a suture shuttle.

The flexible member(s) can be made of a variety of materials, but in one exemplary embodiment it is a surgical filament that is separate from the filament that forms the snare and collapsible loop. In some embodiments the flex-

ible member is formed using a surgical filament, such as a cannulated filament, a braided filament, and a mono filament. The type, size, and strength of the filament can depend, at least in part, on the other materials of the system, including the material(s) of the filament through which it will pass, the obstructions through which the snare will pass, how the filament is being used (e.g., as a suture pin, as a suture shuttle, or as a joint suture pin and suture shuttle), and the type of procedure in which it is used. In one exemplary embodiment the flexible member is formed from a #2-0 filament (about 28 gauge), such as an Orthocord™ filament that is commercially available from DePuy Mitek, Inc. or Ethibond™ filament available from Ethicon Inc. Generally the flexible member is relatively thin to minimize any trauma to tissue through which it passes, and typically the flexible member is thinner than filament through which it passes. In some embodiments the flexible member can have a size between about a #1 filament (about 25 gauge to about 26 gauge) and about a #6-0 filament (about 38 gauge to about 40 gauge). A length of the flexible member can be in the range of about 1 centimeter to about 100 centimeters. In one embodiment in which the flexible member is only being used as a suture pin it can have a length of about 2 centimeters. In one embodiment in which the flexible member is used as both a suture pin and a suture shuttle it can have a length of about 100 centimeters.

FIG. 8 illustrates one exemplary embodiment of a suture 70 for use as part of the surgical repair construct 10. The suture is generally a flexible member having one or more stationary protrusions 72 formed therein. The protrusions 72 can have a spaced-apart arrangement, can be pre-formed by the suture manufacturer, or alternatively, a surgeon can form one or more of the protrusions 72 in advance of or during a surgical procedure. Different spaced-apart arrangements can be used for different procedures with the spaced-apart relationship being based, at least in part, on the other components of the surgical repair construct 10, the tissue(s) that will be coupled to the suture 70, and the type of procedure being performed. In the illustrated embodiment, there are four protrusions 72 approximately equidistant from each other, although any number of protrusions, including by way of non-limiting example six, in any form of spaced relationships can be used. The protrusions 72 can be used to assist in grasping soft tissue for repair to help prevent the collapsed snare 50 of the filament 20 from backlashing and to provide additional strength to the tissue-to-bone attachment.

One skilled in the art will appreciate that protrusions 72 can be formed by placing a knot in the suture 70, or by affixing another object to the suture 70.

The suture can be made of any suitable suture material, such as a cannulated filament, a braided filament, and a mono filament. The type, size, and strength of the filament can depend, at least in part, on the other materials of the system, including the material(s) of the filament with which it will be coupled, the tissue(s) through which the suture may pass, and the type of procedure in which it is used. In one exemplary embodiment the suture is formed from a size #2 (23-24 gauge) filament, such as an Orthocord™ filament that is commercially available from DePuy Mitek, Inc. or Ethibond™ filament available from Ethicon, Inc. Generally the suture is relatively thin to minimize any trauma to tissue through which it passes. In some embodiments the suture can have a size between about a #5 filament (about 20 gauge) and about a #4-0 filament (about 32 gauge to about 34 gauge). A length of the suture can be in the range of about 10 centimeters to about 120 centimeters, and in one embodiment the suture has a length of about 90 centimeters. Still

further, a diameter of the protrusions can be in the range of about 0.5 millimeters to about 2 millimeters, and in one embodiment the diameter of each of the protrusions is about 1 millimeter. Additionally, a length of a space between each of the protrusions can be in the range of about 1 millimeter to about 10 millimeters, and in one embodiment the length of the space between each protrusion is about 5 millimeters. The diameters of the protrusions along a length of the suture and a length of a space between each of the protrusions can all be the same, or they can vary from protrusion to protrusion.

One exemplary method for performing a rotator cuff repair using the repair construct 10 illustrated in FIG. 1 is schematically illustrated in FIGS. 9A-9E. A surgical opening can be formed through skin 104 and a cannula can be passed therethrough to create a surgical repair site in a manner well known to those skilled in the art. Although cannulas are often used to define a channel through which the procedure can be performed, the cannula is not shown in FIGS. 9A-9E for ease of illustration. Accordingly, to the extent the figures show components of the systems and devices passing through skin 104, these components would typically be extending through the cannula, which itself is passed through the skin 104. Further, although the devices and methods described herein are particularly useful for minimally invasive surgery, such as arthroscopic surgery, they can also be used in open surgical procedures.

As shown in FIG. 9A, the suture 70 can be passed through a tendon 102 detached from bone 100 such that at least one of the protrusions 72 is disposed adjacent to at least one side of the tendon 102. In the illustrated embodiment, two protrusions 72 are located proximal of the tendon 102 while two protrusions 72 are disposed within the tendon 102. Although not shown, it is understood that one or more protrusions can be formed on the distal side of the tendon 102, as opposed to within it. The suture 70 can be passed completely or partially through the tissue using any number of techniques known to those skilled in the art, including by coupling a needle or similar tool or device to one of terminal ends 74 of the suture 70 to assist with threading the suture 70 through the tendon 102. In one exemplary embodiment, one of the terminal ends 74 is passed through the tendon 102 from a first (proximal) side of the tendon 102 facing away from the adjacent bone 100 and back through the tissue from a second (distal) side of the tendon 102 facing towards the bone 100 such that first and second limbs 76, 78 of the suture 70 extend from the first side of the tendon 102, i.e., proximal of the tendon 102. The suture 70 can be manipulated by a surgeon with respect to the tendon 102 to expose as many protrusions 72 as desired. Protrusions 72 located proximal of and adjacent to the tendon 102 can be used to help maintain a location of the collapsed snare 50 as well as to accommodate variations in tissue thickness and the bite size (i.e., the distance between the locations that the suture limbs enter the tissue). In one embodiment it is particularly useful to have at least two fully-exposed protrusions in close proximity to the tendon 102. A person skilled in the art will recognize that there are other ways by which the suture 70 can be coupled to or shuttled through the tendon 102, including, by way of non-limiting example, by wrapping the suture 70 around the tendon 102 such that at least one of the protrusions 72 is proximal of the tendon 102. Further, the suture can be passed through tissue (e.g., tendon 102) through a variety of techniques and orientations known to those skilled in the art.

As shown in FIG. 9B, the anchor 90 can be fixated into bone 100 using ordinary techniques, such as with a driver to

13

screw or tap the anchor **90** into place. In the illustrated embodiment the filament **20** is already coupled thereto at the engagement feature **92**, although in other embodiments the filament **20** can be slidably coupled to the anchor **90** after the anchor **90** is positioned at its desired location. As shown, the filament **20** includes the snare **50**, the collapsible loop **30**, the sliding knot **36**, and the collapsible tail or tensioning limb **40**.

As shown in FIG. **9C**, the terminal ends **74** of the first and second limbs **76**, **78** of suture **70** can be passed through the opening **52** of the snare **50**, thereby placing the tendon **102** in a position to be coupled to the filament **20**. The snare **50** can then be advanced distally towards the bone **100**, for instance by sliding the snare **50** along the suture **70**, until the snare **50** is distal of at least one of the protrusions **72** and proximal of the tendon **102**. As shown in FIG. **9D**, the snare **50** can be advanced distal of two protrusions **72** and is located approximately adjacent to the tendon **102**. In other embodiments the snare **50** can be advanced distal of three or more protrusions **72**. Any number of techniques known to those skilled in the art can be used to advance the snare **50** distally, including using a pusher tool or advancing it by hand.

After the snare **50** has been advanced distally past at least one of the protrusions **72** and to its desired location, the snare **50** can be collapsed or dressed in a manner consistent with its snare type. Collapsing the snare **50** around the suture couples the tendon **102** to the filament **20** and directs it towards the bone **100**. In some embodiments, a flexible member can be disposed through the snare **50** to prevent unintentional collapse of the snare opening **52**. In such embodiments, the flexible member can be removed prior to collapsing or dressing the snare. Further, although in the illustrated embodiment the snare **50** is collapsed after it is advanced distally past at least one of the protrusions **72**, in other embodiments the snare **50** can be at least partially collapsed prior to fully advancing it in the distal direction provided that the opening **52** in the snare **50** is still configured to allow at least one of the protrusions **72** to pass therethrough.

As shown in FIG. **9E**, tension can be applied to the tensioning limb **40** by pulling approximately in a direction **D**, thereby causing the sliding knot **36** to advance distally towards the bone **100** to decrease a size of the opening **38** of the collapsible loop **30**, i.e., shorten the collapsible loop **30**. This movement also applies additional tension to the suture **70** by virtue of being coupled to the filament **20**, and in turn brings the tendon **102** into proximity with the bone **100**. The configuration of the filament **20** in conjunction with the suture **70** allows the knot **36** to be advanced in an incremental, ratchet-like fashion when the tensioning limb **40** is pulled in the direction **D** without the risk of reversing the progress of the knot **36** as a result of slipping backward, sometimes referred to as backing out, backlashing, or slackening of the filament. Optionally, as shown, excess portions of the terminal ends **74** of the suture **70** proximal of the protrusions **72** can be cut-off and removed. Likewise, an excess portion of the tensioning limb **40** can also be cut-off and removed if desired. In embodiments in which the filament includes a stationary terminal tail or limb adjacent to the tensioning limb, excess portions of that limb can likewise be cut-off and removed if desired. Still further, optionally, one or more half-hitches can be added to the filament **20**, for instance on the tensioning limb **40**, the suture **70**, or a stationary terminal limb if such limb exists, to provide additional strength once the filament **20** and suture **70** have been finally positioned to approximate tissue.

14

Other than the optional half-hitches, no knots need to be tied during the course of the illustrated procedure.

The resulting break strength of the formed attachment can be in the range of about 50 Newtons to about 200 Newtons without the formation of any half-hitches, and in one embodiment the break strength can be about 130 Newtons without the formation of any half-hitches. The use of half-hitches typically increases the load capacity.

The procedure discussed with respect to FIGS. **9A-9E** is just one example of a procedure that can be performed in conjunction with systems, devices, and methods disclosed herein. A person skilled in the art will recognize a number of other ways that the disclosed systems, devices, and methods can be used in various other configurations and types of surgical procedures. For example, although the filament **20** of FIGS. **9A-9E** is coupled to an anchor, in other embodiments, no anchor can be used and instead repair constructs of the nature disclosed herein can be coupled directly to bone without an anchor. Alternatively, repair constructs of the nature disclosed herein can be used to draw two or more tissues together by passing a filament of a construct through one tissue, a suture having one or more stationary protrusions formed thereon through a second tissue, and the operating the construct in a manner consistent with the teachings herein. Further, the systems, devices, and methods can easily be adapted to be used in conjunction with three or more components, such as multiple tissues and a bone or three or more soft tissue components. Some non-limiting examples of other systems, devices, assemblies, constructs, and surgical procedures with which the present systems, devices, and methods can be used are described in U.S. patent application Ser. No. 13/218,810 filed Aug. 26, 2011, and entitled "SURGICAL FILAMENT SNARE ASSEMBLIES," and in U.S. patent application Ser. No. 13/465,288 filed concurrently herewith, and entitled "Systems, Devices, and Methods for Securing Tissue", the content of which was previously incorporated by reference herein in their entireties.

One skilled in the art will appreciate further features and advantages of the invention based on the above-described embodiments. Accordingly, the invention is not to be limited by what has been particularly shown and described, except as indicated by the appended claims. By way of non-limiting example, although the embodiments described herein include a snare formed in a first end of the filament, other components having similar functionality can be associated with the first end of the filament, such as a clip or a like element to clamp a portion of the suture. Further, although the systems, devices, and methods provided for herein are generally directed to surgical techniques, at least some of the systems, devices, and methods can be used in applications outside of the surgical field. All publications and references cited herein are expressly incorporated herein by reference in their entirety.

What is claimed is:

1. A surgical repair method, comprising:

passing a first end of a suture having a plurality of stationary protrusions through detached soft tissue, the first end being passed through the tissue such that first and second limbs of the suture extend from the first side of the tissue, the suture being arranged in tissue such that at least one of the protrusions is disposed adjacent to at least one of the first and second sides of the tissue; inserting an anchor into bone in proximity to the detached soft tissue, the anchor having a filament associated therewith;

## 15

coupling the filament associated with the anchor to at least one of the first and second limbs of the suture at a location on the limb that is between a protrusion of the plurality of stationary protrusions on the limb and the first side of the tissue, the location being distal of the protrusion of the plurality of stationary protrusions on the limb; and

drawing the detached soft tissue toward the bone into which the anchor is inserted.

2. The method of claim 1, wherein drawing the detached soft tissue toward the bone further comprises applying tension to the filament in a direction away from the tissue.

3. The method of claim 1, wherein coupling the filament associated with the anchor to at least one of the first and second limbs of the suture further comprises coupling the filament associated with the anchor to each of the first and second limbs of the suture at a location on at least one of the limbs that is between a protrusion of the plurality of stationary protrusions on the limb and the first side of the tissue, the location being distal of the protrusion of the plurality of stationary protrusions the limb.

4. The method of claim 3, wherein the coupling step is performed such that the location at which the filament is coupled to each of the first and second limbs of the suture is between a protrusion of the plurality of stationary protrusions on each of the first and second limbs and the first side of the tissue, the location being distal of the protrusion of the plurality of stationary protrusions on each of the first and second limbs.

5. The method of claim 1, wherein the filament associated with the anchor includes a collapsible snare, and the step of coupling the filament associated with the anchor to at least one of the first and second limbs of the suture further comprises collapsing the snare around the at least one of the first and second limbs of the suture.

6. The method of claim 5, further comprising:

inserting at least one of the first and second limbs of the suture through an opening defined by the collapsible snare,

wherein the step of collapsing the snare around the at least one of the first and second limbs of the suture occurs after the collapsible snare is positioned at the location on the limb that is between a protrusion of the plurality of stationary protrusions on limb and the first side of the tissue.

7. The method of claim 5, wherein a flexible member is disposed in a portion of the filament to prevent unintentional collapse of the collapsible snare, the method further comprising removing the flexible member from the filament prior to collapsing the snare.

8. The method of claim 1,

wherein the filament associated with the anchor includes a collapsible loop defined by a sliding knot, and the location at which the filament associated with the anchor is coupled to at least one of the first and second limbs of the suture is proximal of the sliding knot, and wherein drawing the detached soft tissue toward the bone into which the anchor is inserted further comprises advancing the sliding knot distally to reduce a circumference of the collapsible loop.

9. The method of claim 8, wherein advancing the sliding knot distally to reduce a circumference of the collapsible loop further comprises applying tension to a tensioning limb of the filament that extends from the sliding knot.

10. The method of claim 1, wherein the method is performed without tying a knot.

## 16

11. A surgical repair method, comprising:

passing at least one terminal end of a suture having a plurality of stationary protrusions and coupled to detached soft tissue through a first collapsible opening of a filament such that a portion of the suture is disposed in the first collapsible opening, the filament extending from an anchor disposed in bone proximate to the detached soft tissue;

collapsing the first collapsible opening around the portion of the suture disposed in the first collapsible opening such that the collapsed first collapsible opening is disposed between the detached soft tissue and at least one protrusion of the plurality of stationary protrusions; and

drawing the detached soft tissue toward the bone in which the anchor is disposed.

12. The surgical method of claim 11, wherein drawing the detached soft tissue toward the bone further comprises collapsing a second collapsible opening of the filament.

13. The surgical method of claim 12, wherein collapsing a second collapsible opening of the filament further comprises advancing a sliding knot that is formed on the filament distally towards the anchor.

14. The surgical method of claim 13, wherein advancing a sliding knot further comprises applying tension to a tensioning limb of the filament that extends from the sliding knot.

15. The surgical method of claim 11, wherein collapsing the first collapsible opening further comprises moving a sliding knot with respect to the filament to decrease a circumference of the first collapsible opening.

16. The surgical method of claim 11, wherein a flexible member is disposed in a portion of the filament to prevent unintentional collapse of the first collapsible opening, the method further comprising removing the flexible member from the filament prior to collapsing the first collapsible opening.

17. The surgical method of claim 11, wherein passing at least one terminal end of a suture having a plurality of stationary protrusions and coupled to detached soft tissue through a first collapsible opening of a filament further comprises passing both terminal ends of the suture through the first collapsible opening of the filament such that the portion of the suture that is disposed in the first collapsible opening includes a first limb associated with a first terminal end of the both terminal ends of the suture and a second limb associated with a second terminal end of the both terminal ends of the suture.

18. The surgical method of claim 17, wherein collapsing the first collapsible opening around the portion of the suture disposed in the first collapsible opening occurs such that the collapsed first collapsible opening is disposed between the detached soft tissue and at least one protrusion of the plurality of stationary protrusions formed on each of the first and second limbs.

19. The surgical method of claim 11, further comprising: manipulating the suture with respect to detached soft tissue to which it is coupled such that at least one protrusion of the plurality of stationary protrusions is disposed adjacent to at least one of a first and second side of the detached soft tissue.

20. The method of claim 11, wherein the method is performed without tying a knot.