



US009758049B2

(12) **United States Patent**  
Sullivan et al.

(10) **Patent No.:** US 9,758,049 B2  
(45) **Date of Patent:** \*Sep. 12, 2017

(54) **AUTONOMOUS TRANSPORT VEHICLE CHARGING SYSTEM**  
(71) Applicant: **Symbotic, LLC**, Wilmington, MA (US)  
(72) Inventors: **Robert Sullivan**, Wilmington, MA (US); **Dmitry Vasilyev**, Somerville, MA (US)  
(73) Assignee: **Symbotic, LLC**, Wilmington, MA (US)  
(\* ) Notice: Subject to any disclaimer, the term of this patent is extended or adjusted under 35 U.S.C. 154(b) by 0 days.  
This patent is subject to a terminal disclaimer.

(21) Appl. No.: **15/359,366**  
(22) Filed: **Nov. 22, 2016**  
(65) **Prior Publication Data**  
US 2017/0072809 A1 Mar. 16, 2017

**Related U.S. Application Data**  
(63) Continuation of application No. 14/799,367, filed on Jul. 14, 2015, now Pat. No. 9,499,062, which is a (Continued)  
(51) **Int. Cl.**  
**H02J 7/00** (2006.01)  
**B60L 11/18** (2006.01)  
(Continued)  
(52) **U.S. Cl.**  
CPC ..... **B60L 11/1838** (2013.01); **B60L 11/1844** (2013.01); **B60S 5/00** (2013.01);  
(Continued)  
(58) **Field of Classification Search**  
USPC ..... 320/109  
See application file for complete search history.

(56) **References Cited**  
U.S. PATENT DOCUMENTS  
2,945,604 A 7/1960 Kroll et al.  
3,016,154 A 1/1962 Ugolini et al.  
(Continued)  
FOREIGN PATENT DOCUMENTS  
DE 2150500 4/1973  
EP 2073088 6/2009  
(Continued)  
OTHER PUBLICATIONS  
US 8,290,622, 10/2012, Dooley et al. (withdrawn)

*Primary Examiner* — Yalkew Fantu  
(74) *Attorney, Agent, or Firm* — Perman & Green, LLP

(57) **ABSTRACT**  
A charging system for autonomous transport vehicles including at least one charging contact disposed on each pick floor level of a storage and retrieval system, each of the at least one charging contact being located at a transfer station, at least one power supply configured to supply power to the at least one charging contact, and a controller in communication with the transfer station and being configured to communicate information relating to a transfer of items between the transfer station and a predetermined one of the autonomous transport vehicles and to apply power from the power supply to the at least one charging contact for charging the predetermined autonomous transport vehicle corresponding to the transfer and located at the transfer station, wherein the controller is configured to supply power to the charging contacts simultaneously with the predetermined autonomous transport vehicle exchanging items related to the transfer at the transfer station.

**26 Claims, 14 Drawing Sheets**

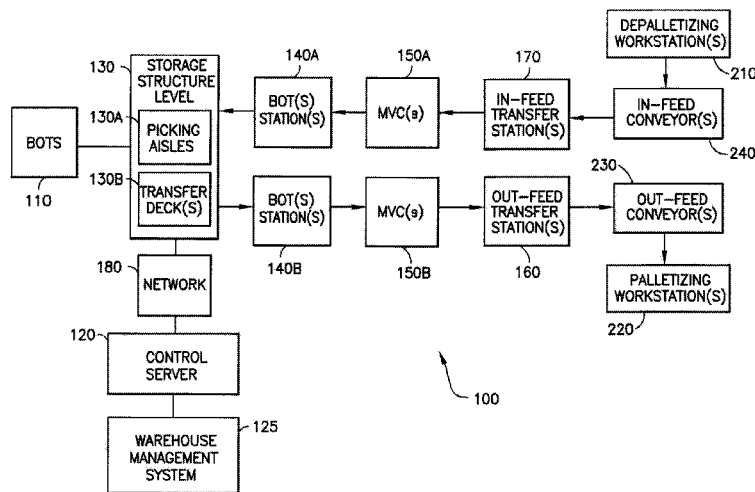

**Related U.S. Application Data**

- continuation of application No. 13/326,823, filed on Dec. 15, 2011, now Pat. No. 9,082,112.
- (60) Provisional application No. 61/423,402, filed on Dec. 15, 2010.
- (51) **Int. Cl.**  
**G06Q 20/10** (2012.01)  
**G06Q 30/02** (2012.01)  
**G06Q 40/00** (2012.01)  
**B65G 47/04** (2006.01)  
**B65G 67/02** (2006.01)  
**B60S 5/00** (2006.01)  
**B65G 1/04** (2006.01)  
**B65G 1/137** (2006.01)  
**G06Q 10/08** (2012.01)
- (52) **U.S. Cl.**  
 CPC ..... **B65G 1/0492** (2013.01); **B65G 1/1373** (2013.01); **B65G 47/04** (2013.01); **B65G 67/02** (2013.01); **G06Q 20/105** (2013.01); **G06Q 30/0215** (2013.01); **G06Q 40/00** (2013.01); **H02J 7/007** (2013.01); **H02J 7/0021** (2013.01); **G06Q 10/087** (2013.01)

(56) **References Cited**

U.S. PATENT DOCUMENTS

3,161,303 A 12/1964 Burrows  
 3,554,390 A 1/1971 Saul  
 3,581,915 A 6/1971 Saul  
 4,428,708 A 1/1984 Burt  
 4,777,416 A 10/1988 George, II et al.  
 4,856,263 A 8/1989 Schneider et al.  
 4,909,697 A 3/1990 Bernard, II et al.  
 4,987,992 A 1/1991 Pflieger  
 5,045,769 A 9/1991 Everett, Jr.  
 5,220,263 A 6/1993 Onishi et al.  
 5,273,392 A 12/1993 Bernard, II et al.  
 5,323,098 A 6/1994 Hamaguchi et al.  
 5,350,270 A 9/1994 Stallard et al.  
 5,395,206 A 3/1995 Cerny, Jr.  
 5,462,439 A 10/1995 Keith  
 5,509,538 A 4/1996 Spindler et al.  
 5,565,755 A 10/1996 Keith  
 5,569,993 A 10/1996 Keith  
 5,664,929 A 9/1997 Esaki et al.  
 5,709,291 A 1/1998 Nishino et al.  
 5,718,322 A 2/1998 Mulhern  
 5,847,537 A 12/1998 Parmley, Sr.  
 6,061,607 A 5/2000 Bradley et al.  
 6,222,342 B1 4/2001 Eggert et al.  
 6,259,228 B1 7/2001 Becker et al.  
 6,262,559 B1 7/2001 Eggert et al.  
 6,289,260 B1 9/2001 Bradley et al.  
 6,325,586 B1\* 12/2001 Loy ..... B65G 1/02  
 414/281

6,377,867 B1 4/2002 Bradley et al.  
 6,394,260 B1 5/2002 Barth et al.  
 6,397,990 B1 6/2002 Brien et al.  
 6,404,168 B1 6/2002 Shoji  
 6,496,755 B2 12/2002 Wallach et al.  
 6,597,150 B1 7/2003 Bertness et al.  
 6,597,151 B1 7/2003 Price et al.  
 6,652,213 B1 11/2003 Mitchel et al.  
 6,764,373 B1 7/2004 Osawa et al.  
 6,836,701 B2 12/2004 McKee  
 6,859,682 B2 2/2005 Naka et al.  
 6,894,457 B2 5/2005 Germagian et al.  
 7,015,674 B2 3/2006 VonderHaar  
 7,054,716 B2 5/2006 McKee et al.  
 7,066,291 B2 6/2006 Martins et al.  
 7,133,746 B2 11/2006 Abramson et al.

7,137,593 B2 11/2006 Baatz  
 7,224,086 B2 5/2007 Germagian et al.  
 D557,206 S 12/2007 Hussaini et al.  
 7,329,081 B2 2/2008 Baker et al.  
 7,332,890 B2 2/2008 Cohen et al.  
 7,352,153 B2 4/2008 Yan  
 7,376,487 B2 5/2008 Kumhyr  
 7,397,213 B2 7/2008 Im et al.  
 7,460,462 B2 12/2008 Mejia et al.  
 7,520,376 B2 4/2009 Bar  
 7,532,947 B2 5/2009 Waddington et al.  
 7,591,630 B2 9/2009 Lert, Jr.  
 7,615,957 B2 11/2009 Kim et al.  
 7,653,457 B2 1/2010 Bloom  
 7,686,560 B2 3/2010 Laurin et al.  
 7,728,549 B2 6/2010 Bartlett et al.  
 7,826,920 B2 11/2010 Stevens et al.  
 7,856,290 B2 12/2010 Kumhyr  
 7,858,227 B2 12/2010 Song et al.  
 7,861,844 B2 1/2011 Hayduchok et al.  
 7,880,431 B2 2/2011 Rayl et al.  
 7,890,228 B2 2/2011 Redmann, Jr. et al.  
 7,894,940 B2 2/2011 Kumhyr  
 7,906,937 B2 3/2011 Bhade et al.  
 7,941,244 B2 5/2011 Somin et al.  
 7,945,798 B2 5/2011 Carlson et al.  
 7,991,505 B2 8/2011 Lert, Jr. et al.  
 8,004,237 B2 8/2011 Manor et al.  
 8,013,570 B2 9/2011 Baxter et al.  
 8,024,064 B1 9/2011 Sanghavi et al.  
 8,028,822 B2 10/2011 Braunstein  
 8,047,756 B2 11/2011 Tuffis et al.  
 8,072,184 B2 12/2011 Bhade et al.  
 8,076,900 B1 12/2011 Brown  
 8,080,975 B2 12/2011 Bessa et al.  
 8,097,356 B2 1/2012 Horikoshi et al.  
 8,253,373 B2 8/2012 Manor et al.  
 8,288,989 B2 10/2012 Baba  
 8,299,750 B2 10/2012 Pai  
 8,344,686 B2 1/2013 Gaul et al.  
 8,350,526 B2 1/2013 Dyer et al.  
 8,354,913 B2 1/2013 Solomon et al.  
 9,082,112 B2 7/2015 Sullivan et al.  
 2002/0124389 A1 9/2002 Matson  
 2004/0088081 A1 5/2004 Song et al.  
 2004/0238326 A1 12/2004 Lichti  
 2005/0212478 A1 9/2005 Takenaka  
 2007/0114975 A1 5/2007 Cohen et al.  
 2007/0216347 A1 9/2007 Kaneko et al.  
 2007/0267998 A1 11/2007 Cohen et al.  
 2008/0007203 A1 1/2008 Cohen et al.  
 2008/0025833 A1 1/2008 Baker et al.  
 2008/0129445 A1 6/2008 Kraimer et al.  
 2008/0174268 A1 7/2008 Koo et al.  
 2009/0074545 A1 3/2009 Lert et al.  
 2009/0138149 A1\* 5/2009 Chattot ..... B60L 1/003  
 701/22

2009/0284245 A1 11/2009 Kirby et al.  
 2009/0315501 A1 12/2009 Li et al.  
 2010/0131182 A1 5/2010 Deegan et al.  
 2010/0145507 A1 6/2010 Blust et al.  
 2010/0277005 A1 11/2010 Karalis et al.  
 2010/0277121 A1 11/2010 Hall et al.  
 2010/0308939 A1 12/2010 Kurs  
 2010/0322747 A1\* 12/2010 Lert ..... B65G 1/045  
 414/273

2011/0058926 A1 3/2011 Winkler  
 2011/0082583 A1 4/2011 Kumhyr  
 2011/0106295 A1 5/2011 Miranda et al.  
 2011/0118903 A1 5/2011 Kraimer et al.  
 2011/0148364 A1 6/2011 Ota  
 2011/0216185 A1 9/2011 Laws et al.  
 2011/0234153 A1 9/2011 Abramson  
 2011/0238206 A1 9/2011 Somin et al.  
 2011/0241845 A1\* 10/2011 Sullivan ..... H01L 21/67294  
 340/10.42

2011/0246252 A1 10/2011 Uesugi  
 2011/0254503 A1 10/2011 Widmer et al.  
 2011/0285349 A1 11/2011 Widmer et al.

(56)

**References Cited**

U.S. PATENT DOCUMENTS

2012/0045303	A1	2/2012	Macdonald
2012/0200256	A1	8/2012	Tse
2012/0200259	A1	8/2012	Sullivan et al.
2012/0235477	A1	9/2012	Korman
2013/0043826	A1	2/2013	Workman et al.
2013/0127415	A1	5/2013	Ohtomo
2014/0312838	A1	10/2014	Dorval et al.
2014/0343717	A1	11/2014	Dorval et al.

FOREIGN PATENT DOCUMENTS

WO	2012119853	9/2012
WO	2012177193	12/2012

\* cited by examiner

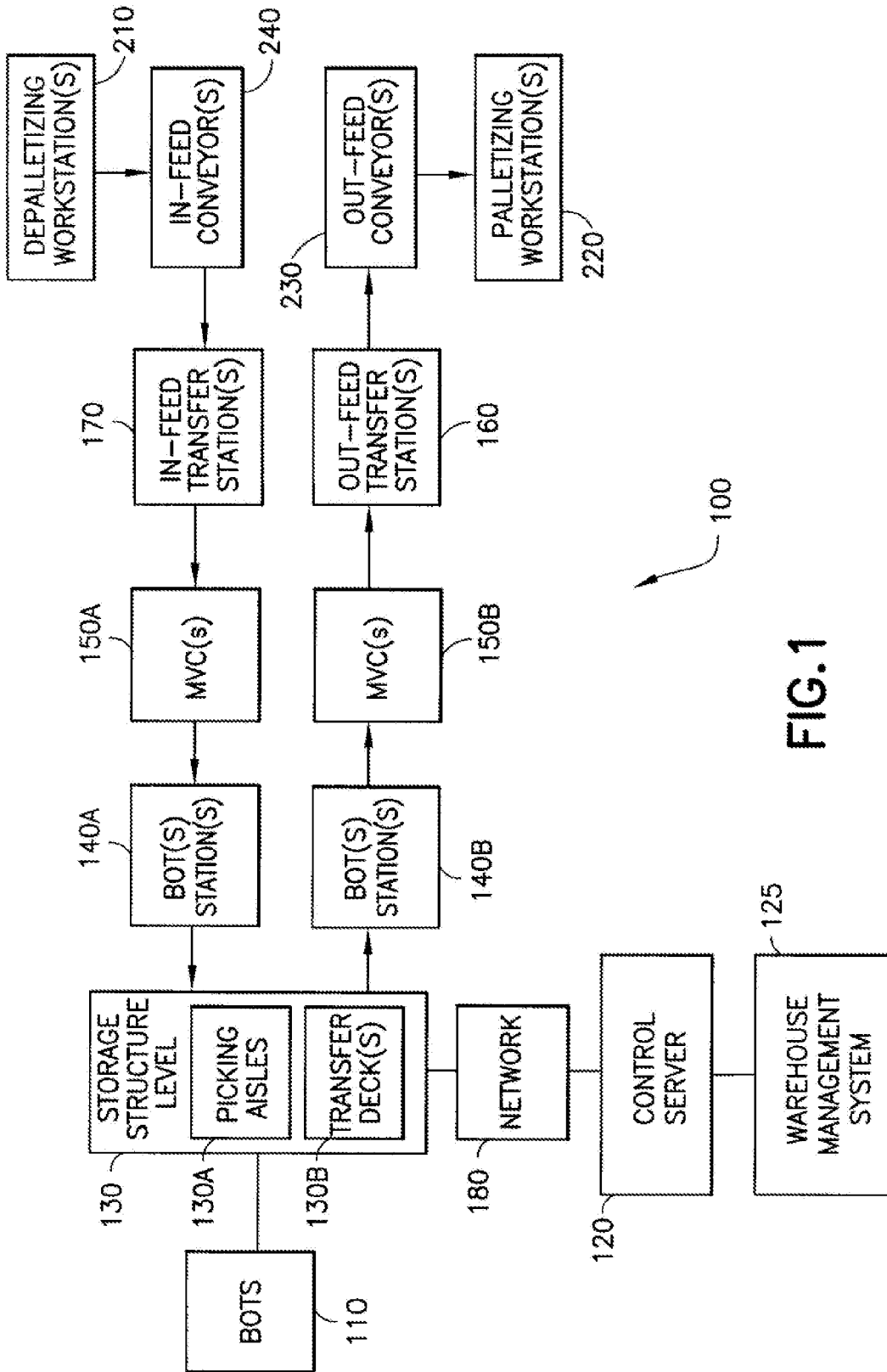

FIG.1

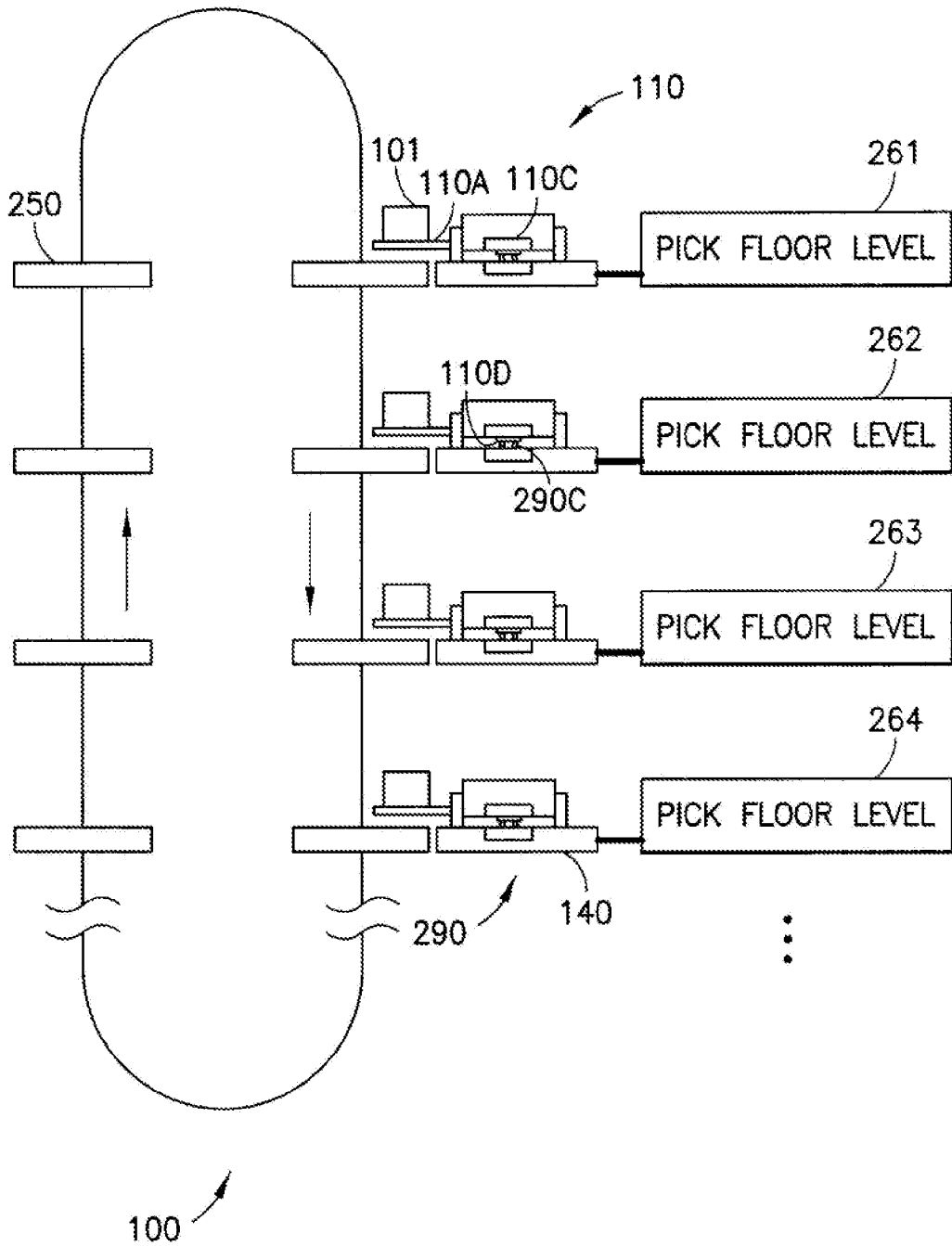

FIG.2A

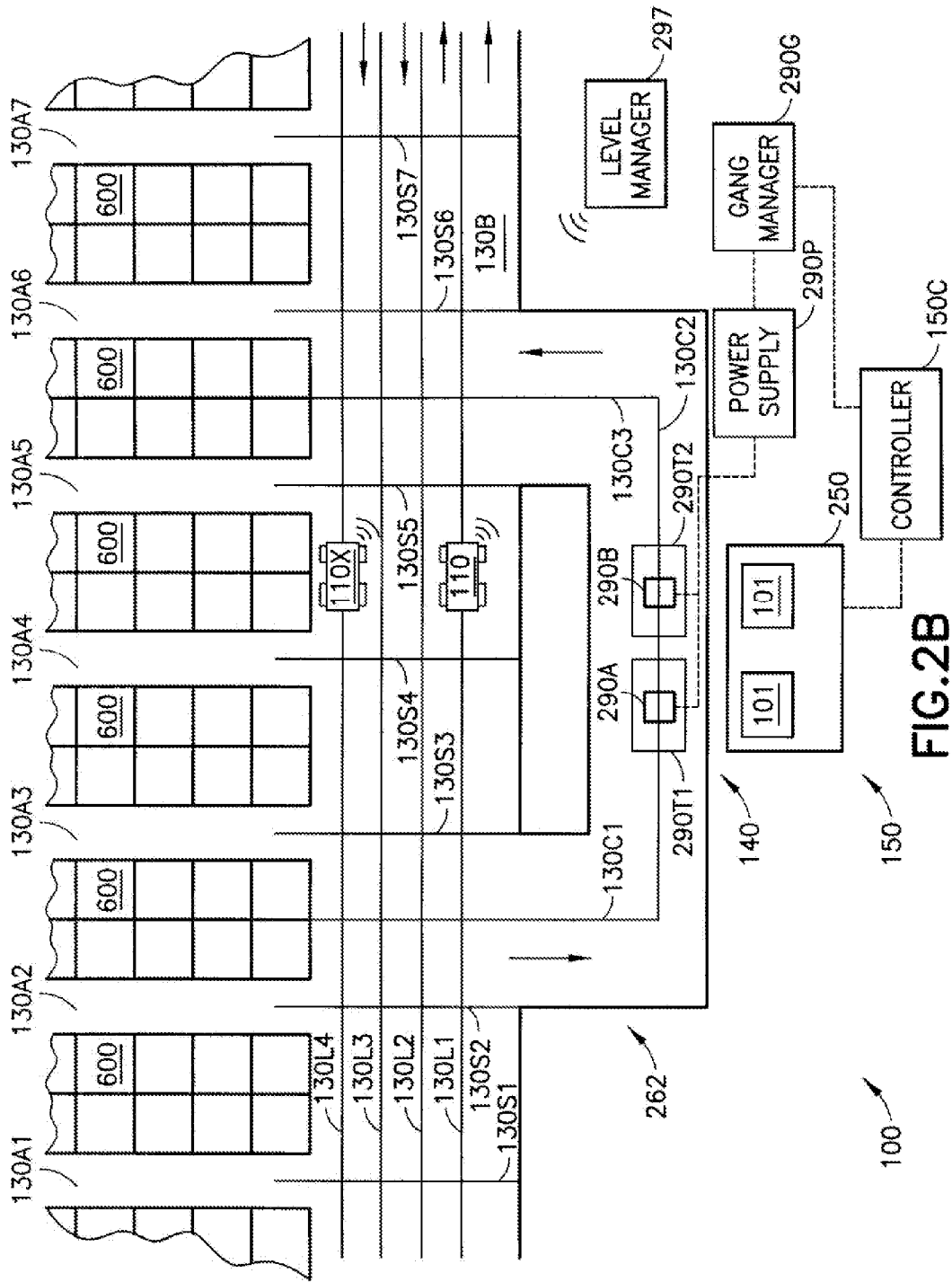

FIG.2B

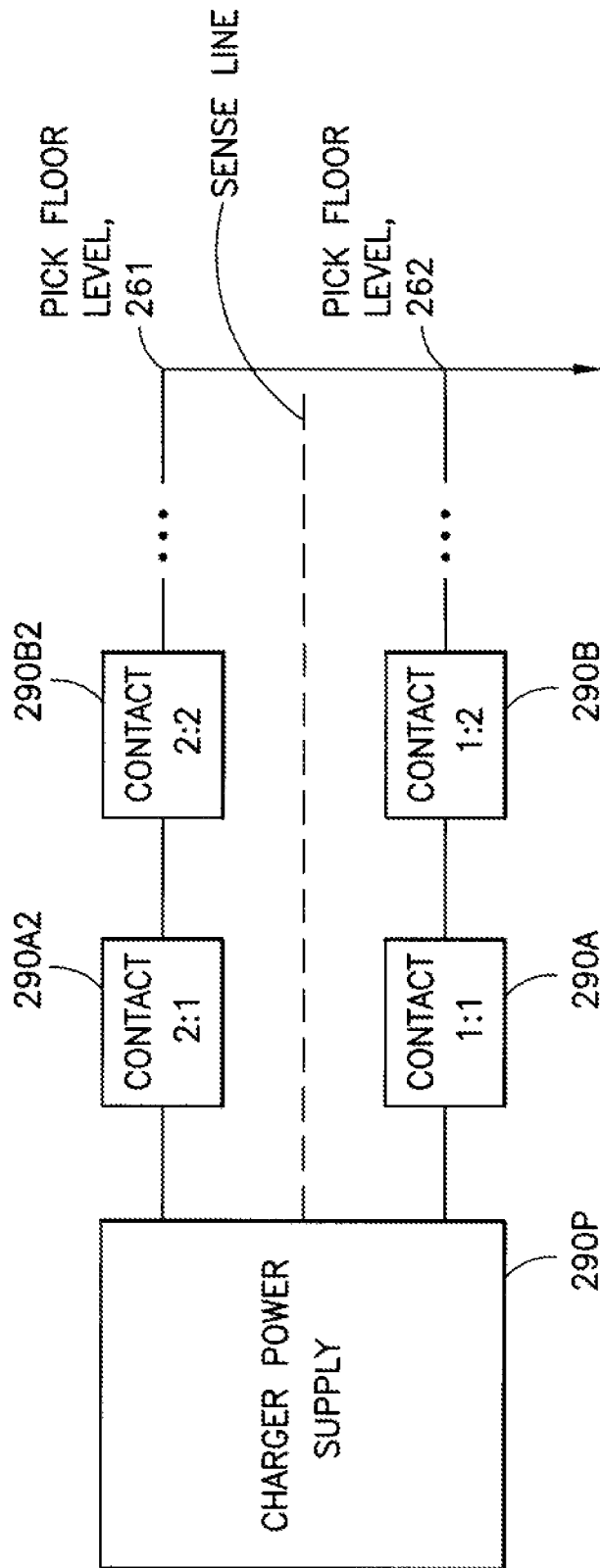
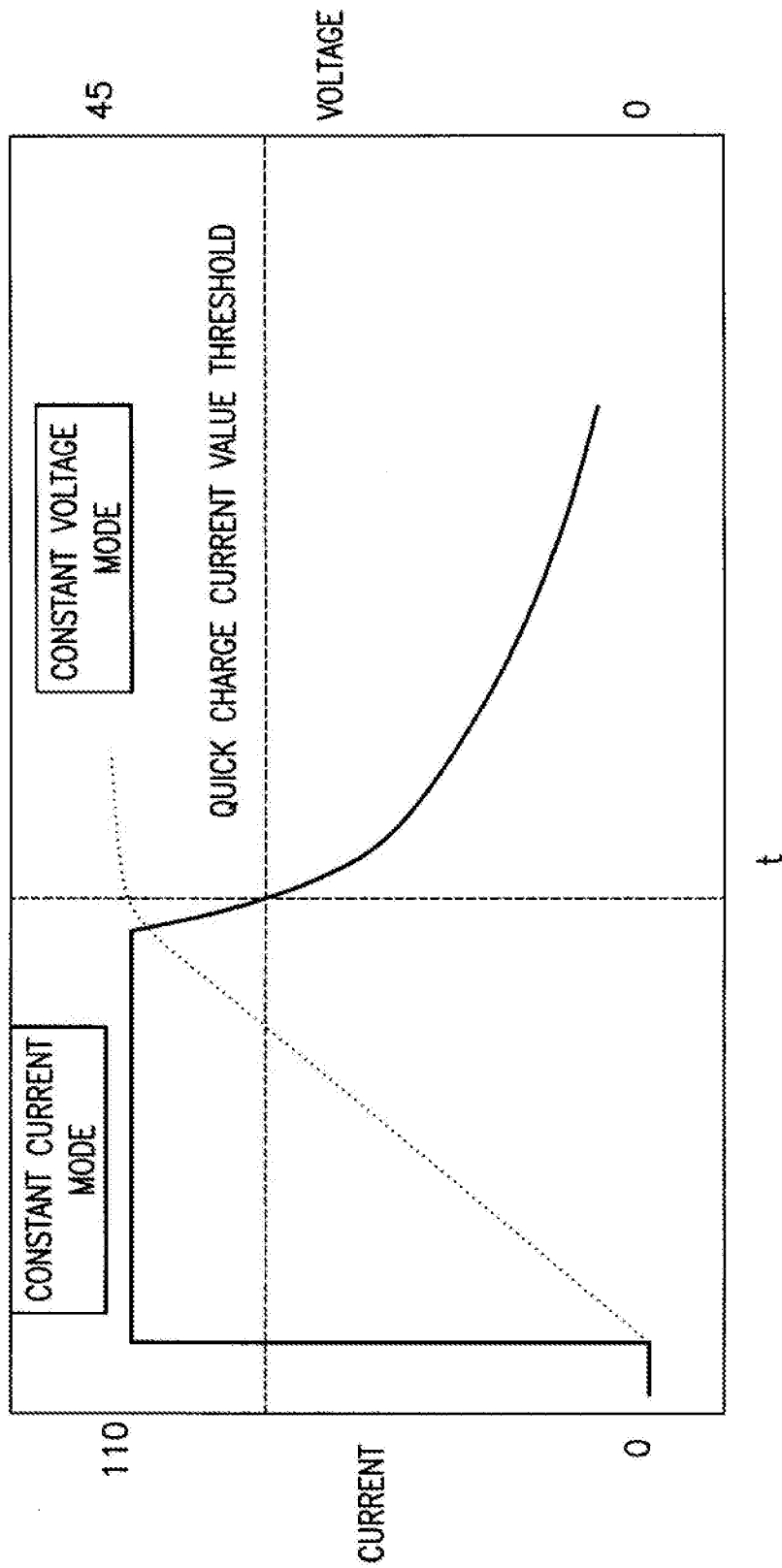

FIG.3



TYPICAL CHARGE CYCLE

FIG.4



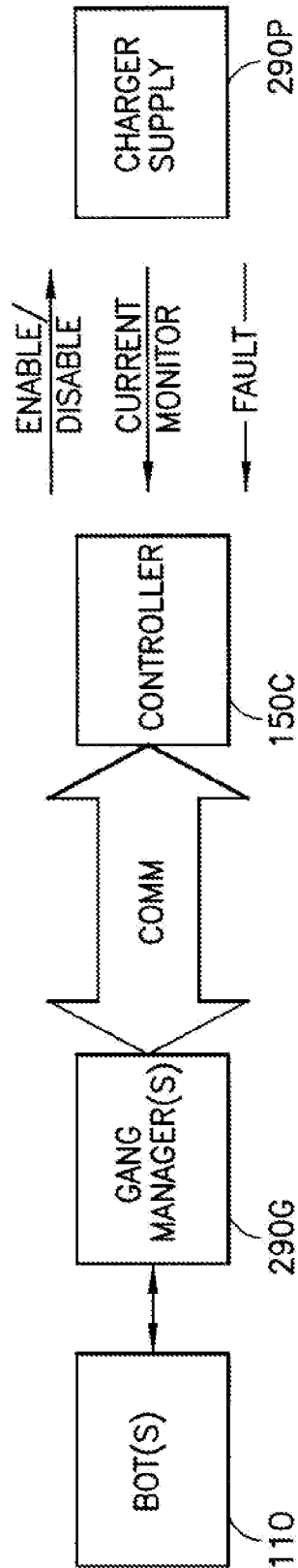

FIG.5

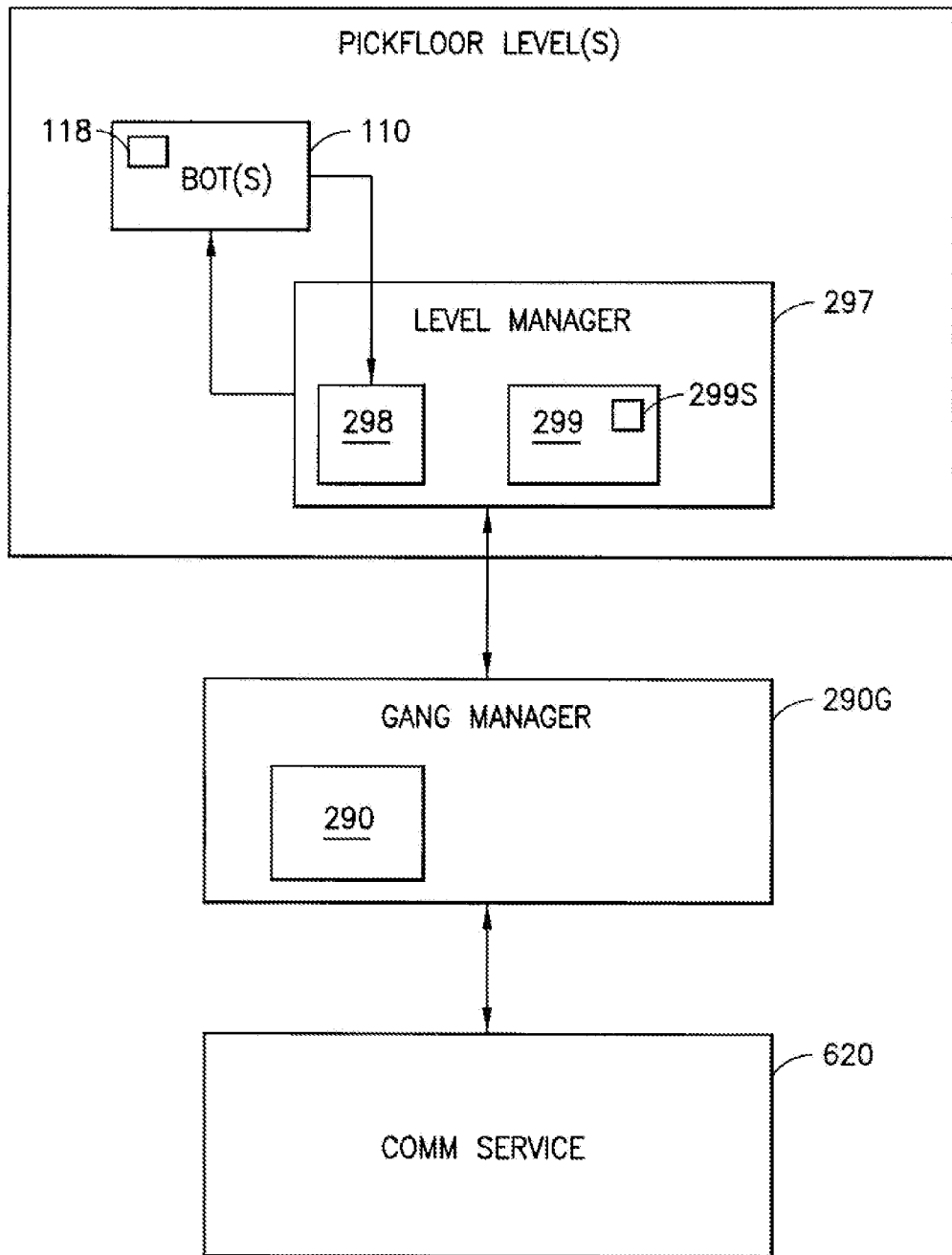

FIG. 6

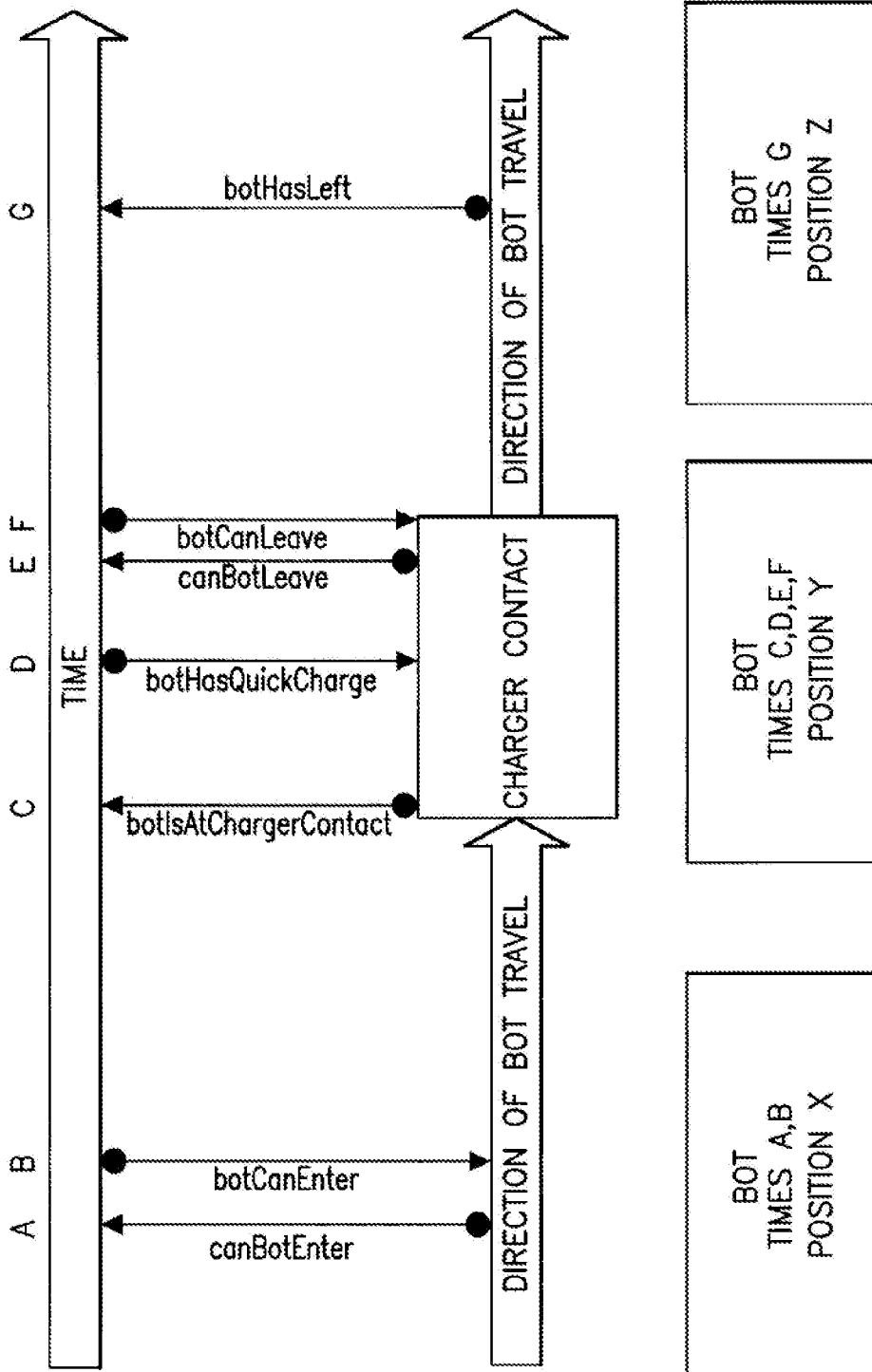

FIG.7

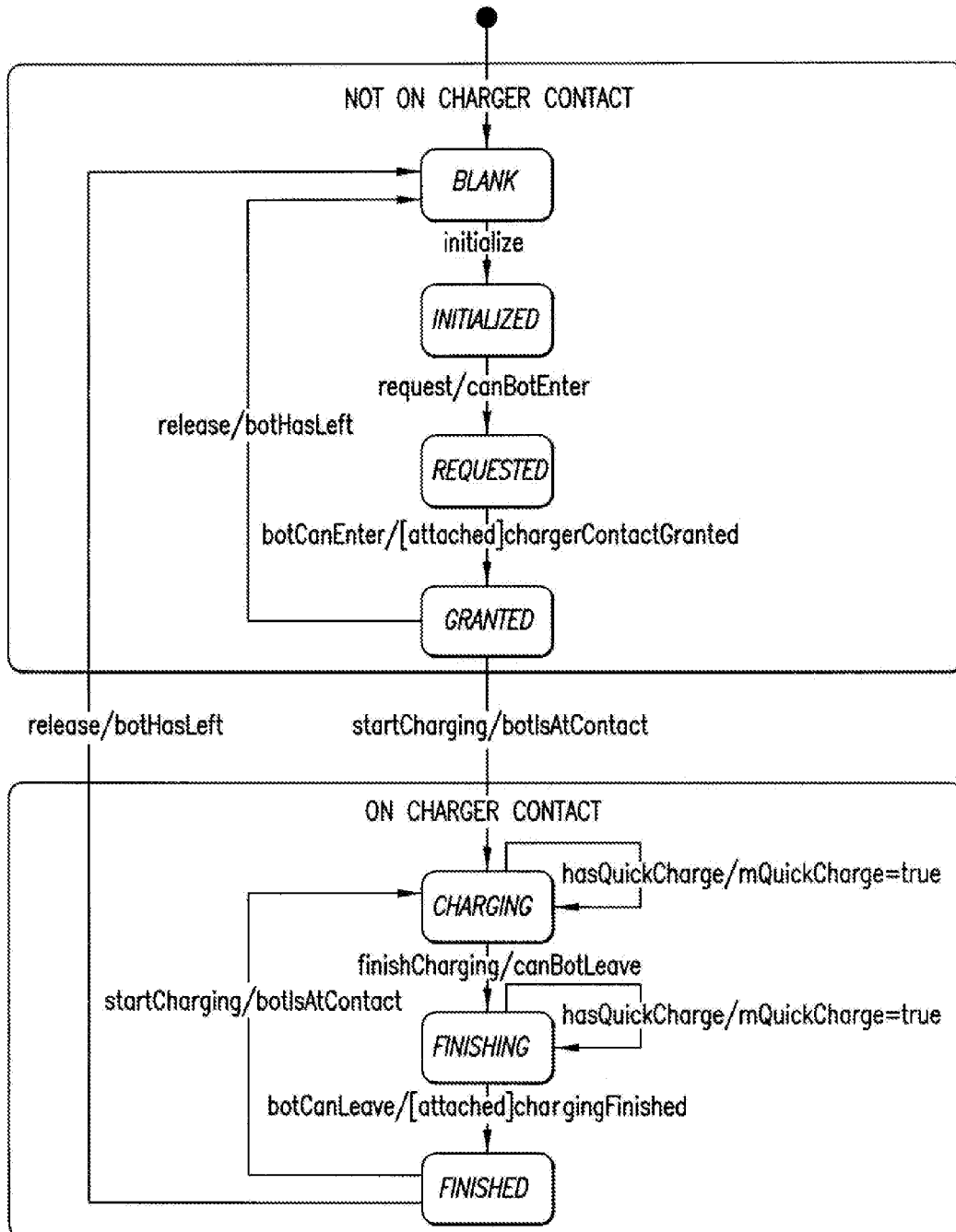

FIG.8

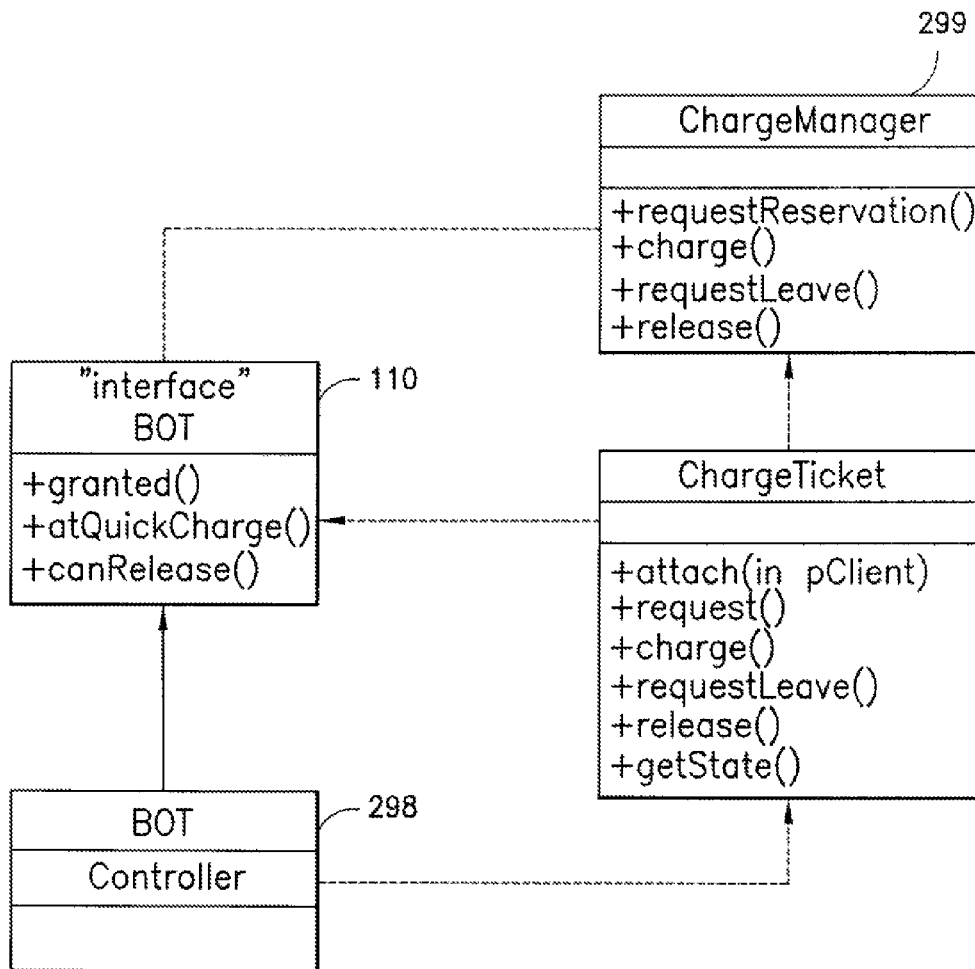

FIG.9

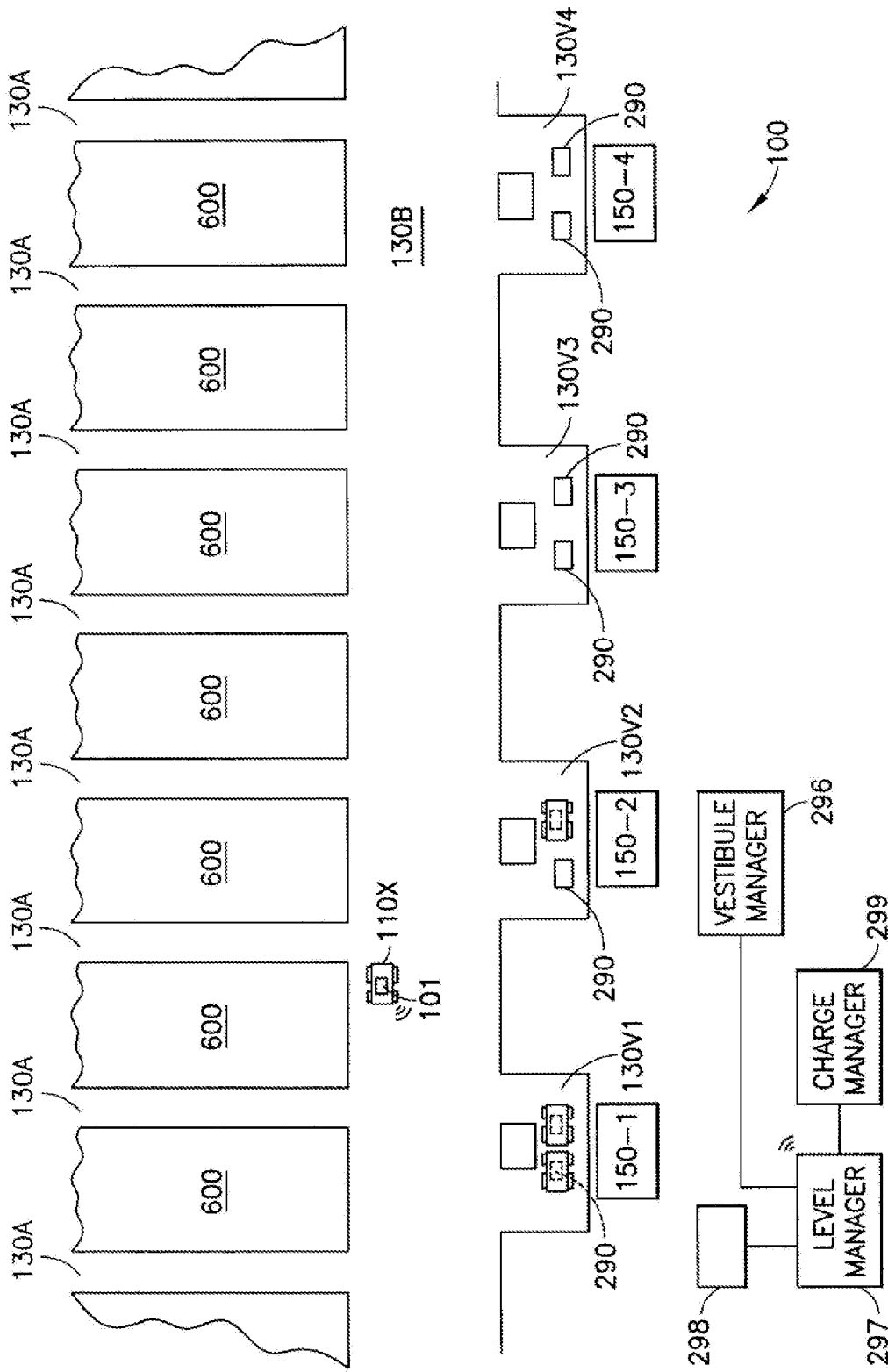

FIG. 10

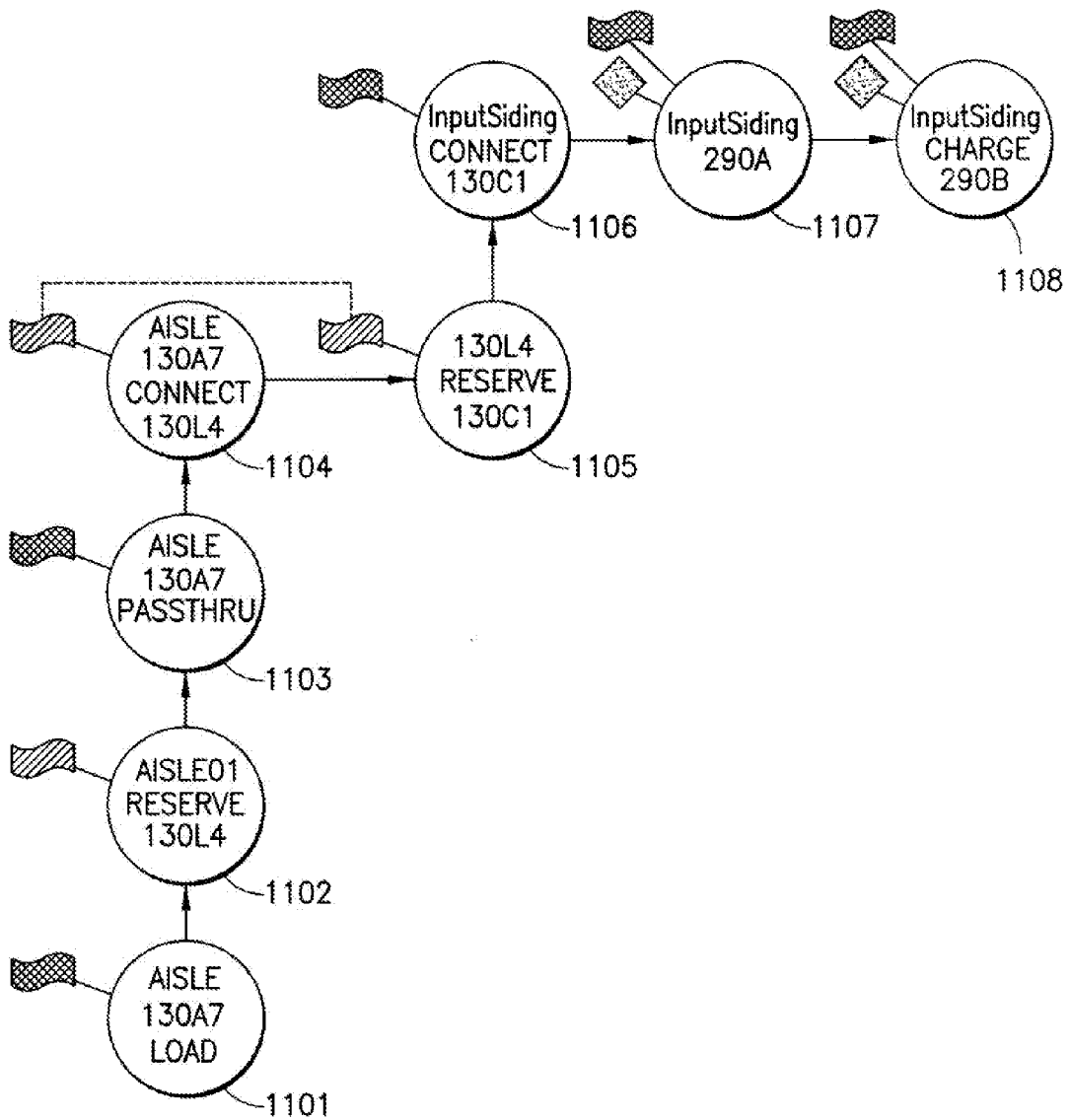

FIG. 11

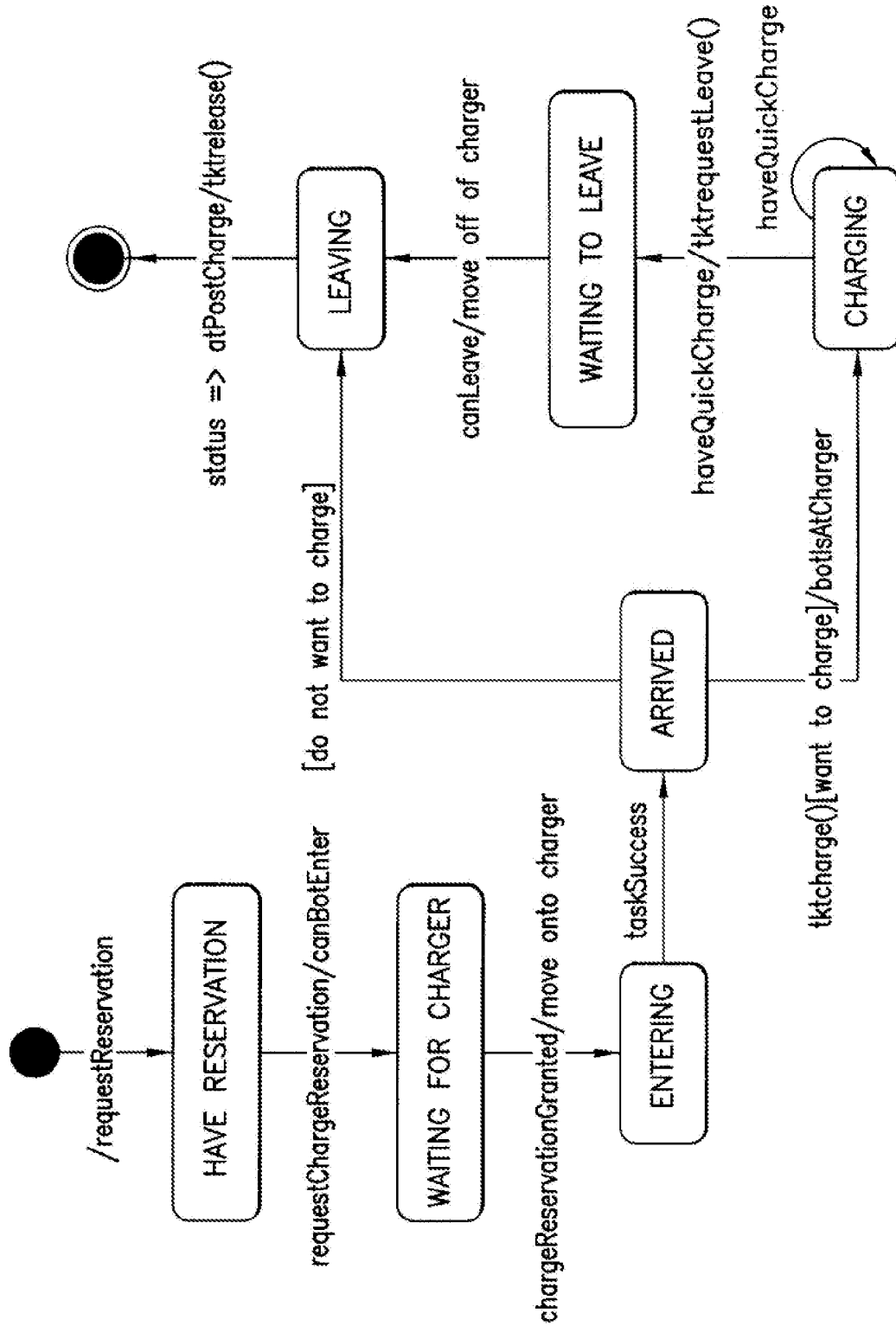

FIG.12



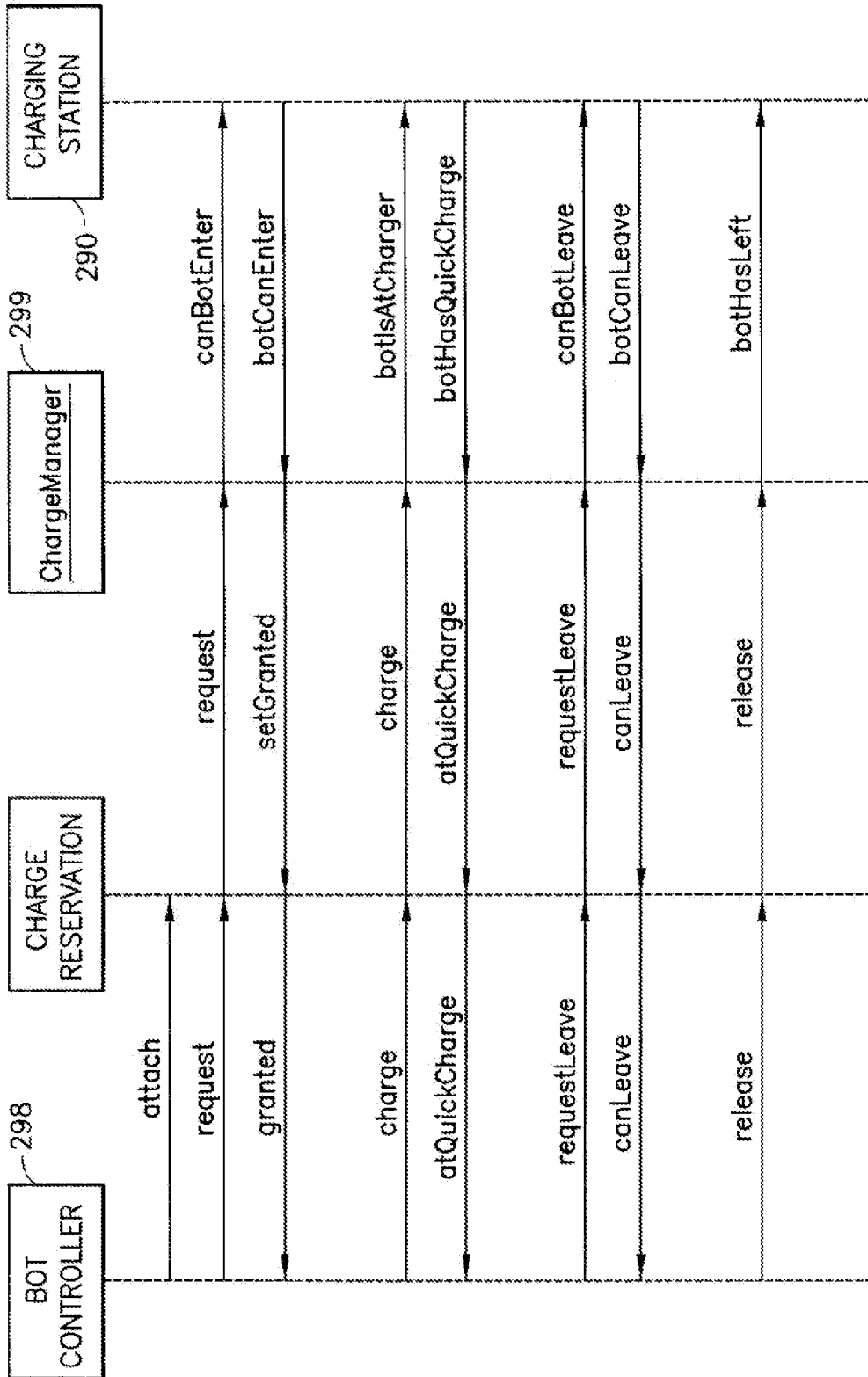

FIG. 13

1

## AUTONOMOUS TRANSPORT VEHICLE CHARGING SYSTEM

### CROSS-REFERENCE TO RELATED APPLICATIONS

This application is a continuation of U.S. patent application Ser. No. 14/799,367, filed Jul. 14, 2015 (now U.S. Pat. No. 9,499,062), which is a continuation of U.S. patent application Ser. No. 13/326,823, filed Dec. 15, 2011 (now U.S. Pat. No. 9,082,112) which claims the benefit of and priority from U.S. provisional patent application No. 61/423,402, filed on Dec. 15, 2010, the disclosures of which are incorporated herein by reference in their entireties.

### BACKGROUND

#### 1. Field

The embodiments generally relate to storage and retrieval systems and, more particularly, to autonomous transports of the storage and retrieval systems.

#### 2. Brief Description of Related Developments

Warehouses for storing case units may generally comprise a series of storage racks that are accessible by transport devices such as, for example, fork lifts, carts and elevators that are movable within aisles between or along the storage racks or by other lifting and transporting devices. These transport devices may be automated or manually driven. Generally the items transported to/from and stored on the storage racks are contained in carriers, for example storage containers such as trays, totes or shipping cases, or on pallets.

It would be advantageous for the automated transport vehicle to operate at substantially full utility while transporting items throughout the storage and retrieval system.

### BRIEF DESCRIPTION OF THE DRAWINGS

The foregoing aspects and other features of the disclosed embodiments are explained in the following description, taken in connection with the accompanying drawings, wherein:

FIG. 1 schematically illustrates an exemplary storage and retrieval system in accordance with the embodiments;

FIG. 2A illustrates a schematic view of a portion of the storage and retrieval system of FIG. 1 in accordance with the embodiments;

FIG. 2B is another schematic illustration of a portion of the storage and retrieval system of FIG. 1 in accordance with the embodiments;

FIG. 3 illustrates a schematic view of a portion of an autonomous transport vehicle charging system in accordance with the embodiments;

FIG. 4 illustrates an exemplary graph of an autonomous transport vehicle charging cycle in accordance with the embodiments;

FIG. 5 is a schematic illustration of an exemplary topology for an autonomous transport vehicle charging system in accordance with the embodiments;

FIG. 6 is a schematic representation of service interactions for an autonomous transport vehicle charging system in accordance with the embodiments;

FIG. 7 is a schematic illustration of an autonomous transport vehicle charging sequence in accordance with the embodiments;

FIG. 8 is an illustration of an exemplary charger state diagram in accordance with the embodiments;

2

FIG. 9 is a schematic illustration of a portion of a communication hierarchy for an autonomous transport vehicle charging system in accordance with the embodiments;

FIG. 10 illustrates a schematic view of a portion of a storage and retrieval system in accordance with the embodiments;

FIG. 11 illustrates a schematic waypoint list for an autonomous transport vehicle in accordance with the embodiments;

FIG. 12 illustrates an exemplary schematic state chart diagram for a portion of an autonomous transport vehicle charging system in accordance with the embodiments; and

FIG. 13 is a schematic illustration of an exemplary sequence diagram for charging transactions of an autonomous transport vehicle charging system in accordance with the embodiments.

### DETAILED DESCRIPTION OF THE EXEMPLARY EMBODIMENT(S)

FIG. 1 schematically illustrates an exemplary storage and retrieval system **100** in accordance with the embodiments. Although the disclosed embodiments will be described with reference to the embodiments shown in the drawings, it should be understood that the disclosed embodiments can be embodied in many alternate forms. In addition, any suitable size, shape or type of elements or materials could be used.

In accordance with the embodiments the storage and retrieval system **100** may operate in a retail distribution center or warehouse to, for example, fulfill orders received from retail stores for case units (where case units as used herein means items not stored in trays, on totes or on pallets, e.g. uncontained or items stored in trays totes or on pallets). It is noted that the case units may include cases of items (e.g. case of soup cans, boxes of cereal, etc.) or individual items that are adapted to be taken off of or placed on a pallet. In accordance with the embodiments, shipping cases or case units (e.g. cartons, barrels, boxes, crates, jugs, totes, pallets or any other suitable device for holding case units) may have variable sizes and may be used to hold items in shipping and may be configured so they are capable of being palletized for shipping. It is noted that when, for example, bundles or pallets of case units arrive at the storage and retrieval system the content of each pallet may be uniform (e.g. each pallet holds a predetermined number of the same item—one pallet holds soup and another pallet holds cereal) and as pallets leave the storage and retrieval system the pallets may contain any suitable number and combination of different items (e.g. each pallet may hold different types of items—a pallet holds a combination of soup and cereal). In the embodiments the storage and retrieval system described herein may be applied to any environment in which case units are stored and retrieved.

The storage and retrieval system **100** may be configured for installation in, for example, existing warehouse structures or adapted to new warehouse structures. In the embodiments, the storage and retrieval system may include in-feed and out-feed transfer stations **170**, **160**, multilevel vertical conveyors **150A**, **150B**, autonomous transport vehicle or robot (referred to herein as “bots”) stations **140A**, **140B**, a storage structure **130**, and a number of bots **110**. Suitable examples of storage and retrieval systems may be found in U.S. patent application Ser. No. 12/757,220, entitled “STORAGE AND RETRIEVAL SYSTEM” and filed on Apr. 9, 2010 and U.S. patent application Ser. No. 12/757,381, entitled “STORAGE AND RETRIEVAL SYSTEM”

and filed on Apr. 9, 2010, and U.S. Provisional Patent Application Ser. No. 61/423,340 entitled “Warehousing Scalable Storage Structure” filed on Dec. 15, 2010 (now U.S. patent application Ser. No. 13/326,674 filed on Dec. 15, 2011), the disclosures of which are incorporated by reference herein in their entireties. The in-feed transfer stations **170** and out-feed transfer stations **160** may operate together with their respective multilevel vertical conveyors **150A**, **150B** for bi-directionally transferring case units to and from one or more levels of the storage structure **130**. It is noted that while the multilevel vertical conveyors **150** are described herein as being dedicated inbound or in-feed conveyors **150A** and outbound or out-feed conveyors **150B**, each of the conveyors **150A**, **150B** may be used for both inbound and outbound transfer of case units/items from the storage and retrieval system. The multilevel vertical conveyors **150** may be any suitable lifting devices for transporting case units between levels of the storage and retrieval system. Some non-limiting suitable examples of multilevel vertical conveyors can be found in, for example, U.S. Provisional Patent Application No. 61/423,298, entitled “MULTILEVEL VERTICAL CONVEYOR PLATFORM GUIDES” filed on Dec. 15, 2010, and U.S. patent application Ser. No. 12/757,354, entitled “LIFT INTERFACE FOR STORAGE AND RETRIEVAL SYSTEMS” and filed on Apr. 9, 2010 (the disclosures of which are incorporated by reference herein in their entireties) and U.S. patent application Ser. No. 12/757,220, entitled “STORAGE AND RETRIEVAL SYSTEM,” (previously incorporated by reference). For example, the multilevel vertical conveyors **150A**, **150B** may have any suitable number of support shelves **250** (FIG. 2) for transporting the case units to a predetermined level **261-264** (FIG. 2) of the storage and retrieval system **100**. The support shelves **250** may have slatted supports configured to allow, for example, fingers of a transfer arm **110A** (FIGS. 2A, 2B) of the bots **110** to pass between the slats for transferring case units **101** (FIG. 2) to and from the conveyor. In alternate embodiments, case units may be indirectly transferred between the bots **110** and the multilevel vertical conveyors **150A**, **150B** as described in, for example, U.S. patent application Ser. No. 12/757,220, entitled “STORAGE AND RETRIEVAL SYSTEM,” (previously incorporated by reference). It is noted that in the embodiments transfer of case units between the bots **110** and multilevel vertical conveyors may occur in any suitable manner.

As may be realized, the storage and retrieval system **100** may include multiple in-feed and out-feed multilevel vertical conveyors **150A**, **150B** that are accessible by, for example, bots **110** on each level of the storage and retrieval system **100** so that one or more case unit(s) can be transferred from a multilevel vertical conveyor **150A**, **150B** to each storage space on a respective level and from each storage space to any one of the multilevel vertical conveyors **150A**, **150B** on a respective level. The bots **110** may be configured to transfer the case units between the storage spaces on storage racks **600** (FIG. 2B) and the multilevel vertical conveyors with one pick (e.g. substantially directly between the storage spaces and the multilevel vertical conveyors). By way of further example, the designated bot **110** picks the case unit(s) from a shelf of a multilevel vertical conveyor, transports the case unit(s) to a predetermined storage area of the storage structure **130** and places the case unit(s) in the predetermined storage area (and vice versa). It is noted that while multilevel vertical conveyors are described herein in other aspects the conveyors may be any

suitable conveyors or transfer/picking devices having any suitable transport path orientation.

The bots **110** may be configured to place case units, such as the above described retail merchandise, into picking stock in the one or more levels of the storage structure **130** and then selectively retrieve ordered items for shipping the ordered items to, for example, a store or other suitable location. As described above, the bots **110** may interface in any suitable manner with the multilevel vertical conveyors **150A**, **150B** such as through, for example, extension of a transfer arm **110A** (FIG. 2A) of the bot (which may have fingers for interfacing with slatted support shelves of the multi-level vertical conveyors) relative to a frame of the bot. In the embodiments the bot may also interface with the multilevel vertical conveyors indirectly in any other suitable manner. Suitable examples of bots are described in U.S. patent application Ser. No. 12/757,312, entitled “AUTONOMOUS TRANSPORTS FOR STORAGE AND RETRIEVAL SYSTEMS” and filed on Apr. 9, 2010, U.S. Provisional Patent Application Ser. No. 61/423,220 entitled “BOT PAYLOAD ALIGNMENT AND SENSING” filed on Dec. 15, 2010 (now U.S. patent application Ser. No. 13/327,040 filed on Dec. 15, 2011), U.S. Provisional Patent Application Ser. No. 61/423,365 entitled “AUTOMATED BOT WITH TRANSFER ARM” filed on Dec. 15, 2010 (now U.S. patent application Ser. No. 13/326,952 filed on Dec. 15, 2011), U.S. Provisional Patent Application Ser. No. 61/423,388 entitled “AUTOMATED BOT TRANSFER ARM DRIVE SYSTEM” filed on Dec. 15, 2010 (now U.S. patent application Ser. No. 13/326,993 filed on Dec. 15, 2011), U.S. Provisional Patent Application Ser. No. 61/423,359 entitled “BOT HAVING HIGH SPEED STABILITY” filed on Dec. 15, 2010 (now U.S. Pat. No. 8,965,619 issued on Feb. 24, 2015), and U.S. Provisional Patent Application Ser. No. 61/423,206 entitled “BOT POSITION SENSING” filed on Dec. 15, 2010 (now U.S. patent application Ser. No. 13/327,035 filed on Dec. 15, 2011), the disclosures of which are incorporated by reference herein in their entireties.

The storage structure **130** may include multiple levels of storage rack modules **600** (FIG. 2B) where each level includes an array of storage spaces (arrayed on the multiple levels and in multiple rows on each level), picking aisles **130A** formed between the rows of storage spaces, and transfer decks **130B**. In the embodiments, the picking aisles **130A** and transfer decks **130B** may be arranged for allowing the bots **110** to traverse respective levels of the storage structure **130** for placing case units into picking stock and to retrieve the ordered case units. As may be realized, the storage and retrieval system may be configured to allow random accessibility to the storage spaces. For example, all storage spaces in the storage structure **130** may be treated substantially equally when determining which storage spaces are to be used when picking and placing case units from/to the storage structure **130** such that any storage space of sufficient size can be used to store items. The storage structure **130** may also be arranged such that there is no vertical or horizontal array partitioning of the storage structure. For example, each multilevel vertical conveyor **150A**, **150B** is common to all storage spaces (e.g. the array of storage spaces) in the storage structure **130** such that any bot **110** can access each storage space and any multilevel vertical conveyor **150A**, **150B** can receive case units from any storage space on any level so that the multiple levels in the array of storage spaces substantially act as a single level (e.g. no vertical partitioning). The multilevel vertical conveyors **150A**, **150B** can also receive case units from any storage space on any level of the storage structure **130** (e.g.

no horizontal partitioning). It is noted that in the embodiments the storage and retrieval system may be configured so that each multilevel vertical conveyor serves a predetermined area of the array of storage spaces. Suitable exemplary configurations of storage and retrieval systems can be found in, for example, U.S. patent application Ser. No. 12/757,381, entitled "STORAGE AND RETRIEVAL SYSTEM" and filed on Apr. 9, 2010, the disclosure of which is incorporated by reference herein in its entirety.

The storage structure **130** may also include charging stations **290** for replenishing, for example, a battery pack, capacitor, ultra-capacitor or other electricity storage device of the bots **110** as will be described in greater detail below. The charging stations **290** may be located at, for example, bot stations **140A**, **140B** (generally **140**) of the transfer deck **130B** so that the bots **110** can substantially simultaneously transfer items, for example, to and from a multilevel vertical conveyor **150A**, **150B** while being charged. The bots **110** and other suitable features of the storage and retrieval system **100** may be controlled by, for example, one or more central system control computers (e.g. control server) **120** through, for example, any suitable network **180**. The network **180** may be a wired network, a wireless network or a combination of a wireless and wired network using any suitable type and/or number of communication protocols. It is noted that, the system control server **120** may be configured to manage and coordinate the overall operation of the storage and retrieval system **100** and interface with, for example, a warehouse management system **125**, which in turn manages the warehouse facility as a whole. The control server **120** may be substantially similar to that described in, for example, U.S. patent application Ser. No. 12/757,337, entitled "CONTROL SYSTEM FOR STORAGE AND RETRIEVAL SYSTEMS" and filed on Apr. 9, 2010, the disclosure of which is incorporated by reference herein in its entirety.

Referring now to FIGS. 2A and 2B, each of the bots **110** in the storage and retrieval system **100** include one or more suitable electricity storage devices for powering the bot **110**. In the embodiments the one or more electricity storage devices may be one or more suitable capacitors or ultra-capacitors (referred to herein generally as capacitor **110C**). While the embodiments are described with respect to capacitors it should be understood that the electrical storage devices, in alternate embodiments, may be any suitable solid state, chemical, or other electricity storage system. Still, the bots may be powered by fossil fuels the replenishing of which may be substantially similar to that described herein.

To enable substantially full (about 100%) bot utility during normal operation (e.g. when the bot is actively transferring items in the storage and retrieval system) or during extended idle time, the bots on each storage level **261-264** of the storage and retrieval system **100** may recharge or replenish their power supplies, such as the one or more capacitors **110C**, at charging locations or stations **290** at the multilevel vertical conveyor **150** exchange areas (e.g. bot/transfer stations **140**). The bots may access the bot stations **140** by, for example, following lines or other suitable guides, such as conveyor access guide lines **130C1-130C3** on the transfer deck **130B**. For example, the transfer deck **130B** may have any suitable number of travel guide lines **130L1-130L4** and any suitable number of shunt or bypass guide lines **130S1-130S7** that form one or more travel paths or lanes for the bots **110** to traverse. For example, guide lines **130L1**, **130L2** allow travel in a first direction and guide lines **130L3**, **130L4** allow travel in a second direction substantially opposite the first direction.

The shunt guide lines **130S1-130S7** may be oriented substantially transverse to the travel guide lines **130L1-130L4** but in other aspects they may have any suitable orientation relative to the travel guide lines. The shunt guide lines **130S1-130S7** allow bidirectional travel of the bots **110** for switching between travel guide lines **130L1-130L4** so that the bots can access, for example, the picking aisles **130A** or the bot stations **140** without traversing an entire length of the travel guide lines **130L1-130L4**. In the embodiments, the shunt guide lines may be aligned with the picking aisles **130A1-130A7** or any other suitable ingress or egress location of the storage and retrieval system allowing the bot to turn down a corresponding picking aisle while travelling along any one of the travel guide lines **130L1-130L4**. The shunt guide lines **130S1-130S7** may also be located at ends of the transfer deck **130B** or at any other suitable locations of the transfer deck **130B**. As an example, a bot **110** travelling along a path corresponding to guide line **130L1** may be instructed to transfer an item to a storage location in picking aisle **130A4**. However, the bot **110** may have already passed the shunt guide line **130S4** corresponding to picking aisle **130A4**. The bot may continue to travel along guide line **130L1** until it encounters the next available shunt (e.g. a shunt not being used by another bot) such as shunt guide line **130S5**. The bot may turn onto shunt guide line **130S5** and then turn onto one of the guide lines **130L3**, **130L4** so that the bot **110** is travelling in substantially the opposite direction towards the picking aisle **130A4**. The bot may continue to travel along one of the guide lines **130L3**, **130L4** until it encounters shunt guide line **130S4**, corresponding to picking aisle **130A4**, where the bot turns onto shunt guide line **130S4** for transitioning into or otherwise entering the picking aisle **130A4** guide way (such as, for example, a rail guidance system). The conveyor access guide lines **130C1-130C3** may be substantially similar to the shunt guide lines **130S1-130S2** however, in the embodiments the conveyor access guide lines may only allow unidirectional travel of the bots **110** through the bot station **140**. For example, conveyor access guide line **130C1** may provide an entrance path into the bot station. Conveyor access guide line **130C2** may provide a pathway for charging the bots **110** and allowing the bots to interface with the multilevel vertical conveyor shelves **250**. Conveyor access guide line **130C3** may provide an exit path into the bot station. The conveyor access guide lines **130C1-130C3** may also provide bidirectional travel of the bots so that the bots **110** can enter and/or leave the bot station using either of guide lines **130C1** or **130C3**. The conveyor access guide lines **130C1**, **130C3** may extend across the transfer deck **130B** so that the bots can access the bot station **140** from any one of the travel guide lines **130L1-130L4** and exit onto any one of the travel guide lines **130L1-130L4** from the bot station **140**. It is noted that while the embodiments of the transfer deck **130B** and bot stations **140** are described herein with respect to line following, the transfer deck **130B** and bot stations **140** may be configured so that the bots are guided by any suitable rail system. In one example, the bots **110** may enter and exit the picking aisles **130A** and the bot stations **140** with either a front end of the bot leading the direction of travel or a back end of the bot leading the direction of travel as described in for example, U.S. Provisional Patent Application Ser. No. 61/423,409 entitled "AUTONOMOUS TRANSPORT VEHICLE" filed on Dec. 15, 2010 (now U.S. patent application Ser. No. 13/326,423 filed on Dec. 15, 2011), the disclosures of which are incorporated herein by reference in their entireties.

In the embodiments, the travel guide lines **130L1-130L4** and shunt guide lines **130S1-130S7** (including guide lines

130C1, 130C3) are arranged so that the bots 110 travel in a substantially counterclockwise direction but it should be realized that the guide lines may be arranged so that the bots travel in a substantially clockwise direction. When traversing the guide lines 130L1-130L4, 130S1-130S7 collisions between the bots 110 may be avoided in any suitable manner such as through bot-to-bot communications or bot location tracking and management through, for example, control server 120 or other suitable bot controller. A suitable example, of bot collision avoidance may be found in, for example, U.S. patent application Ser. No. 12/257,337 entitled "CONTROL SYSTEM FOR STORAGE AND RETRIEVAL SYSTEMS" and filed on Apr. 9, 2010, the disclosure of which is incorporated by reference herein in its entirety.

In the embodiments the bot station 140 may be in the form of a vestibule 130V that extends between the transfer deck 130B and the multilevel vertical conveyor 150. Each vestibule 130V may be configured with more than one charging station 290A, 290B (each of which may also serve as a transfer location for accessing a respective portion of the multilevel vertical conveyor shelf 250) arranged in, for example, a linear array, along guide line 130C2. In this example, there are two charging stations 290A, 290B corresponding with two item holding locations on the multilevel vertical conveyor shelf 250. It is noted that in the embodiments there may be any suitable number of charging stations, which may correspond with a respective number of item holding locations on the multilevel vertical conveyor storage shelf 250.

The charging stations 290A, 290B of each vestibule 130V may be connected to a common power supply 290P as will be described in greater detail below. The common power supply 290P may power the charging stations 290 of multiple bot stations 140. For example, the bot stations 140 may be disposed one above the other in a vertical array or stack so that the bots 110 of each pick floor level 261-264 travel along substantially parallel paths while in the bot stations 140. The storage and retrieval system may include one or more power supplies 290P each of which may be connected to the charging stations 290 of one or more pick floor levels 261-264. Bot 110 ingress and egress to/from the vestibule 130V of the bot station 140 and to the charging stations 290 along, for example, the guide line 130C2 may be synchronized with other bots 110 destined for, leaving, or charging at the charging stations 290 by an access-charge-depart protocol, hosted in any suitable controller of the storage and retrieval system, to maximize substantially full utility of all charging stations 290 of a given vestibule 130V (e.g. to substantially avoid a case where the charging of bots 110 interferes with the ingress/egress process or other bots 110 designated to travel to the same vestibule 130V). Each multilevel vertical conveyor may have any suitable controller 150C, such as a programmable logic controller, for controlling the operations of the respective multilevel vertical conveyor 150 as well as controlling the power supply or supplies of the charging stations 290 disposed on the vestibules 130V providing access to the shelves 250 of the respective multilevel vertical conveyor 150.

The ingress and egress of the bots 110 to the vestibules 130V may be managed by, for example a level manager 297 a portion of which may include a vestibule manager 296 (FIG. 10). The level manager 297 may have any suitable organization so as to, for example, manage bot operations on one or more pick floor levels, in one or more stacks of bot stations 140 (e.g. bot stations 140 located one above the other), or in geographical regions of the storage and retrieval

system. The level manager 297 may be in communication with the bots 110 in any suitable manner using any suitable communication protocol. For example the communication between the bots 110 and the level manager 297 may be a wired or wireless bidirectional and/or unidirectional communications, Linux based communications, etc. In the embodiments each pick floor level 261-264 may have its own respective level manager 297 for controlling or otherwise managing movement of the bots 110 on the respective level and/or, one level manager may manage more than one pick floor level 261-264. The level manager 297 may be configured such that it tracks the location of operative bot charging stations 290 and communicates with a gang manager 290G (FIG. 2B—described below) for obtaining access to the chargers and the status of bot 110 charges. The vestibule manager 296 may manage the areas in which the charging stations 290 are located for determining if access is available before, for example, the gang manager 290G requests access to the charging stations. As will be described below, if one or more charging station 290 in a vestibule is inoperative the vestibule manager 296 may, in the embodiments, close the vestibule (e.g. deny access so that bots are directed to other vestibules) with the inoperative charging station(s) 290.

Each bot 110, through any suitable onboard controller or manager, may communicate with the level manager to effect a charge cycle on the bot 110 in combination with a case unit 101 exchange with a multilevel vertical conveyor 150 on the pick floor level 261-264 on which the bot 110 is located. Each charging station 290A, 290B includes contacts 290C for interfacing with corresponding contacts 110D (e.g. such as a charger pad) on the bot 110 for charging, for example, the bot's capacitor(s) 110C. The contacts 290C may be any suitable contacts such as spring loaded or other actuable contacts that are configured to engage the contacts 110D of the bot 110 when the bot is positioned substantially over the charging station 290A, 290B. These charging station contacts 290C may be positioned at the charging stations 290A, 290B such that they interface with the contacts 110D of a bot 110 when the bot 110 is positioned for interface and exchange with one of the holding locations of the multilevel vertical conveyor shelf 250. As described above the bots access the vestibules 130V of the bot stations 140 through an access-charge-depart protocol that may include getting permission to travel on to the charger contacts 290C (prior to item exchange with the multilevel vertical conveyor), initiating charge, and getting permission to leave (after item exchange with the multilevel vertical conveyor). The level manager 297 may be configured to manage the requests for access to the vestibules 130V and charging stations 290A, 290B and make decisions on whether to allow bots 110 to enter, leave and initiate/terminate charging accordingly. A charge can be initiated once the bot 110 has gained access and stops on one of the charging stations 290A, 290B corresponding to a location on the shelf 250 the bot 110 is to pick/place an item. The charging of the bot 110 may occur during the time it takes to transfer an item between the bot 110 and the shelf 250 or after the transfer has completed. In addition, the bot 110 may charge at the nearest available (e.g. unallocated) vestibule 130V without interfering with other transfers (non-determinative, opportunity charging).

In the embodiments, the bots 110 may perform a quick charge before leaving the multilevel vertical conveyor vestibule 130V, at which point the multilevel vertical conveyor controller 150C may inform a gang manager 290G (FIG. 2B) that a quick charge has been achieved. The quick charge of the bot 110 may be a charge that terminates (or signals

ready for termination) at the point where the power supply **290P** switches from a constant current mode (e.g. the power supply is delivering maximum current output with variable voltage) to a constant voltage mode (e.g. where the power supply has reached the maximum voltage output set point with a variable current). It is noted that the bot **110** may remain at the charging station **290A**, **290B** and continue to charge (e.g. to achieve a top off or full charge) until, for example the control server **120** or other suitable controller of the storage and retrieval system deems necessary to move the bot **110**, such as to allow another bot **110** access to the charging stations **290A**, **290B**.

During a quick charge the capacitor **110C** of the bot **110** may be at a voltage that does not take into account losses from the power supply **290P** to the capacitor **110C**. During a top off or full charge the extended period for the capacitor to reach the applied voltage level ( $\tau = R * C$ ,  $5 * \tau \approx 99.3\%$  of final voltage, where  $R$  is the combined ESR of the capacitor and any resistance between the power supply sense lines (FIG. 3) and the capacitor). The gang manager **290G** may be a collection of cooperating interfaces that manages gang charging of bots **110** (e.g. charging more than one bot at a time where a gang is a group of bots that are charged by the same power supply) on multiple pick floor levels **261-264** that share a power supply. In the embodiments there may be one gang manager **290G** per power supply **290** or each gang manager may serve multiple power supplies. In the embodiments, the bots **110** may not have access to a charging station **290** if the power supply **290P** is enabled and operational (e.g. power is being transferred to the charging station waiting to be accessed). In the embodiments, after charging and the power supply **290P** stops transmitting power to the charging station **290** the gang manager **290G**, for example, may cause the bot **110** to remain at the charging station **290** for a predetermined amount of time, which in one example, may be about 280 milliseconds. In other examples, the amount of time the bot **110** remains at the charging station **290** after the power is turned off may be any suitable time period.

Referring to FIGS. 3 and 4, there may be, for example, four charging stations **290A**, **290B**, **290A2**, **290B2** per power supply **290P**. The charging stations **290A**, **290B**, **290A2**, **290B2** may be vertically placed within a single multilevel vertical conveyor **150** area and disposed in a rectangular configuration with two charging stations **290A**, **290B** on one pick floor level and two charging stations **290A2**, **290B2** on another different pick floor level, where the pick floor levels may be adjacent to one another. As an example, referring back to FIG. 2A, in this power supply configuration the charging stations of pick floor levels **261**, **262** would share a power supply, the charging stations of pick floor levels **263**, **264** would share a power supply, etc. It is noted that in the embodiments there may be any suitable number of charging stations on each pick floor level that share a power supply with any suitable number of charging stations from one or more other pick floor levels. Each power supply **290P** may be located within a predetermined distance to the charging stations **290** that it serves. For example, power supply **290P** may be located less than about 18 feet from the charging stations **290A**, **290B**, **290A2**, **290B2** to, for example, reduce wiring loss and increase charging throughput. It is noted that in the embodiments, the power supplies **290P** may be located any suitable distance from their respective charging stations **290**.

As described above, each power supply may be controlled by, for example, a controller **150C** of a respective multilevel vertical conveyor **150**, or any other suitable controller. In the

embodiments there can be up to about sixteen power supplies **290** and up to about sixty-four charging stations **290** associated with a single multilevel vertical conveyor **150** where the charging stations are located on different pick floor levels. In the embodiments, the controller **150C** may be configured such that when the multilevel vertical conveyor is stopped (e.g. power is shut off to the conveyor) the charging stations **290** will remain operational. Power to the charging stations **290** and the multilevel vertical conveyor may be individually disabled/enabled.

Referring to FIGS. 2B and 3, and with respect to pick floor level **262** for exemplary purposes, the bot charging process may initiated before the bot **110** enters the multilevel vertical conveyor area (e.g. the bot station **140**). The bot may initiate communication with the gang manager **290G** to request permission to drive on to a particular charging station **290A**, **290B**. In the embodiments, the decision on which charging station **290A**, **290B** the bot is to interface with may be dependent on which multilevel vertical conveyor shelf **250** is the intended target and in which location of the shelf **250** the item to be transferred is to be picked from or placed to.

The Bot may remain out of the charging station **290A**, **290B** area (e.g. the load/unload area of the multilevel vertical conveyor) until it receives permission from, for example, the control server **120** (or other suitable controller such as the vestibule manager of the level manager) that it is safe to enter the charging station **290A**, **290B**. In one example, the gang manager **290G** may have knowledge of any other bots **110** on the pick floor level (which in this example is pick floor **262**) that may access the charging station **290A**, **290B** and may command controller **150C** to turn off the power supply **290P** for allowing a bot **110** to enter the charging station **290A**, **290B**. In one example, the gang manager **290G** may have the discretion to decide when to turn off the power supply **290P** and when to allow the bot **110** on to the charging station **290A**, **290B**.

Once the Bot has permission to move in to the charging station **290A**, **290B** (e.g. the multilevel vertical conveyor load/unload area), the bot **110** may maneuver to the intended charging station **290A**, **290B** and report its position accordingly. Once the bot **110** is located at the intended charging station **290A**, **290B**, the gang manager **290G** may communicate to the controller **150C** to re-enable the power supply **290P**, at which point the bot **110** will begin charging. This charging of the bot **110** may overlap with charging of other bots **110** that are on the same shared charging system network (e.g. if bot **110** is charging at charging station **290A**, other bots **110** may be also be charging at one or more of charging stations **290B**, **290A2**, **290B2**). In the embodiments, the charging process is open ended and may not terminate until commanded to do so by, for example, the gang manager **290G** or other suitable controller of the storage and retrieval system **100**.

The controller **150C** may control the power supply **290P** and monitor a status of the power supply **290P**. The controller **150** may monitor the status of the power supply **290P** and report to, for example, the gang manager **290G** when the power supply **290P** has reached a constant voltage mode and measures a current output falling below about 75% of its maximum value. It is noted that in the embodiments, the controller **150C** may report to, for example, the gang manager **290G** at any suitable time such as when the current output is above or below about 75%. At this point, the bot **110** has been "Quick Charged" and can be ready to perform tasks as needed. The gang manager **290G** may send a command to terminate the charge cycle if the bot **110** is

needed to transport items within the storage and retrieval system **100**. If the Bot is not needed, charging may continue and the charger supply may remain on indefinitely. It is noted that in the embodiments the power to the charging station being used may be shut off upon a predetermined condition such as when, for example, the bot reaches a “full charge.” A full charge may be accomplished if the Bot remains charging for about five R\*C time constants. The time to reach a full charge may be dependent on, for example, such factors including the resistance between the charger station contact **290C** and the contacts **110D** of the bot **110**, the wiring on the bot **110** as well as the resistance inside the capacitor **110C**. In one example, a bot **110** may leave the charging station **290A**, **290B** any time after a quick charge.

In the embodiments there may be N number of gang managers **290G** controlling N number of power supplies **290P**. For example, the controller **150C** of each multilevel vertical conveyor **150** may have addressable ports unique to each power supply **290P**. The bot **110** when requesting a charge may communicate, through for example, level manager **297** (FIG. 2B), with a gang manager **290G** controlling a power supply **290P** for a charging station to which the bot **110** will travel. As described above, the communication between the bots **110** and the level manager **297** as well as the gang manager **290G**, controller **150C** and power supply **290P** (and other suitable components of the storage and retrieval system) may be any suitable communication protocol and methods such as, for example, wired or wireless bidirectional and/or unidirectional communications, Linux based communications, or other suitable communications.

Referring to FIG. 6, in the embodiments the level manager **297** may manage the bots **110** on a level (or more than one level) to which the level manager **297** is assigned. The level manager **297** may include a bot controller **298** for use by the bots **110**, and conversely each bot **110** may include a controller **118** for use by the bot controller **298**. There may be, for example, a one to one mapping between the bot controller **298** and each bot **110** (e.g. the level manager **297** includes one bot controller for each bot) or, one bot controller may be mapped to more than one bot. The level manager **297** may also include a charge manager **299** that may act as an intermediary between the bot controller **298** and the gang manager **290G** to manage charging.

Each bot controller **298** may communicate with the gang manager **290G** via the charge manager **299** to effect charging of the bot **110**. In the embodiments there may be, for example, ten multilevel vertical conveyors that intersect the pick floor levels **261-264** (e.g. with twenty charging stations **290** disposed at each pick floor level—e.g. two charging stations per multilevel vertical conveyor intersection). It is noted that in the embodiments there may be any suitable number of multilevel vertical conveyors and charging stations per pick floor level. The charge manager **299** may choose the appropriate charging station **290** to converse with for a given charge cycle. Since bot gangs (e.g. groups of bots charged using the same power supply) span adjacent levels, two level managers **297** may each establish communication connections with the charging stations **290** of their respective levels (which in this example, is twenty charging stations per level).

Conversely, each charge manager **299** may include a charging station status server **299S** for each charging station **290**, that the gang manager **290G** uses to relay power supply status information sent to it by a charging communication service **620**. It is noted that the charging communication service **620** may handle status requests from, for example,

the controller **150C**, on/off requests for, as an example, controller **150C**, and requests to enter/leave a charging station **290**. Since each gang manager **290G** may manage two pick floor levels, it may have connections to, for exemplary purposes only, about four such charging station status server objects, e.g. two for each pick floor level. There may be as many named instances for requests to enter/leave a charging station **290** (e.g. a request instance) as there are charger stations **290**. In one example, each group of four request instances maps to a portion of the charging communication service that handles on/off requests, and hosts a portion of the charging communication service that handles charging station status requests.

In an exemplary operation, the bot controller **298** may issue tasks for the bot **110**. It is noted that when issuing tasks for the **110**, the bot controller **298** may allow for an efficient exchange of items between the bots **110** and the multilevel vertical conveyors. When issuing these tasks the bot controller **298** may do so such that bots **110** are not held up from entering the bot stations **140** (and charging areas **290**) for commencing item transfer with the multilevel vertical conveyor **150**. Also, when issuing tasks the bot controller may not prevent egress of bots from the charging areas **290** because of bots **110** that have not finished charging or have not received a minimum amount of charge. It is also noted that if a first bot **110** has not completed a case unit **101** transfer with the multilevel vertical conveyor **150** any bots located in charging stations **290** behind the first bot **110** may remain in their charging stations to continue receiving a charge.

Referring to FIG. 7, when issuing tasks the bot controller may be aware of when the bot **110** needs to enter the charging station **290**, and when the bot **110** is at the charging station **290**. However, the bot controller **298** may not be aware of exactly when in time the bot **110** clears or leaves the charging station **290**. The bot controller **298** and the bot **110** may cooperate with each other to create a charging cycle. In an exemplary charging cycle, the bot controller may identify the appropriate charging station **290** to communicate with. The bot controller **298** may request (e.g. a “can bot enter” message) that the charge manager **299** send a “bot can enter” message to the charging station **290**. The gang manager **290G** may verify that the charging station **290** is turned off and waiting for a charger status to reflect the off status. The gang manager **290G** may send a charger status and “bot can enter” message to the charge manager **299**, which relays it to the bot controller **298**. The bot controller **298** may issue other tasks to the bot **110** via the controller **118**. When the bot **110** reaches the charging station **290**, the bot controller **298** may wait for a “bot is at charging station” message in order to read a simulated bot voltage and ask the charge manager **299** to send a “bot is at charging station” message to, for example the gang manager **290G**. The charge manager may send a “bot has quick charge” message when the bot **110** has received a quick charge. This allows the level manager **297** to mark the bot **110** as available for other tasks, when it finishes any current job, such as the transfer of items between the bot **110** and the multilevel vertical conveyor. When the bot controller **298** deems that the bot **110** should move out of the charging station **290**, it asks the charge manager to send a “can bot leave” message, to for example, the gang manager **290G**. The gang manager **290G** verifies that at least a quick charge has been delivered to the bot **110**, turns off the charging station **290** if necessary, and sends a “bot can leave” message, which gets relayed to the bot controller **298** and then to the controller **118**. This allows the simulated bot to update its voltage at the end of

a charge cycle. It is noted that the simulate bot may exist in the any suitable memory of any suitable controller of the storage and retrieval system such that based on the tasks sent to the bot, the controller can determine how much of a charge remains in the bot. It is noted that in the embodiments, the bots 110 may periodically send a message to the controller indicating a charge status of the bots 110 or that the bots 110 need to be charged. The bot controller 298 may send the next set of tasks to the bot 110. When the bot 110 deems that it is safely out of the charging area, the bot 110 may send a "bot has left" message, which causes the bot controller 298 to send a "bot has left" message via the charge manager 299. The bot 110 need not wait for an acknowledgement or stop its motion to send this message. The power supply 290P gets re-enabled by the gang manager 290G if necessary for other bots remaining at the charger stations 290.

In the embodiments, separately from any ongoing charge cycle interactions, the gang manager 290G may relay power supply status information to, for example, the level manager 297 so that the level manager may route bots 110 away from unavailable chargers. It is noted that the level manager 297 may establish, through for example, the gang manager 290G the operational status of each of the charging stations 290 and whether the charging stations 290 are available.

It is noted that each bot goes through the same charging sequence described above. In the embodiments, the gang manager 290G may be configured to reconcile multiple pending charge requests by turning each of the charging stations on and off, individually or in groups, as needed. The gang manager may also be configured to collectively turn off the charging stations by, for example, turning off the power supply 290P. This is done by keeping track of the number of bots 110 moving to/from the charging stations 290, and the number of bots at the charging stations 290. One non-limiting example, of keeping tracking of bots 110 is as follows:

Request	Actions
Can Bot Enter	If necessary, the charger is turned OFF When the charger is confirmed to be OFF: iNumMoving++ Send botCanEnter
Bot Is At Contact	iNumMoving- iNumAt++ if(!iNumMoving && iNumAt)turn_charger_on( )
Can Bot Leave	If bot has not received one charge cycle, defer request until such charge is received or power supply fails or is disabled. Charger is turned OFF if necessary When the charger is confirmed to be OFF: iNumMoving++ Send botCanLeave
Bot Has Left	iNumMoving- if(!iNumMoving && iNumAt) turnChargerOn( )
Charger Status	If charger passed the quick charge mark, mark all bots at charger to have received a quick charge so they can leave if desired. Send the botHasQuickCharge( ) message. If charger turned off as a result of having been turned off, update all bot states as outlined previously so bots can enter or leave the charger contact. If the charger had an error, send notification on appropriate ChargerContactStatus::isAvailable( ) interfaces.

The term "Comm Failure" may be used to indicate that the two sides of a communication connection get an "unbind" indication. Conversely, the "bind" indication indicates a (re)connection between the two sides. The following outlines non-limiting exemplary charging specific actions that may be done upon various failures.

Activity	Value	Rationale
Comm message transaction time	About 1 second	Expected worst case time for a comm message to reach destination
Maximum power supply cutoff voltage	About 46.3 V	Power supply specification
Power supply turn off time	About 2 seconds	Hardware behaviour
Power supply maximum current	About 110 A	Power supply field configuration
Highest bot capacitance	About 181.5 F	The supercap used on the bots is nominally about 165 F, allow 10% variation
Maximum charge time for a bot	About 305 seconds	Largest voltage delta to quick charge =MaxPowerSupplyCutoff - 0 V =about 46.3 V Smallest current while charging =Power supply minimum current/ MaxContactsPerSupply =111/4 =about 27.25 A Worst case time to charge =max_capacitance * max_delta_V/ min_current =181.5 * 45.3/27.25 =about 303 seconds Additional about 2 seconds to turn off supply at end.
Time for bot to move to contact after having received permission to do so	X seconds	Allowance for bot
Time for bot to move	Y seconds	Allowance for bot



-continued

Activity	Value	Rationale
away from contact after having received permission to do so		
Overall margin	About 10%, minimum, about 1 second	Additional margin for all timeout calculations

The following are non-limiting exemplary timeout values that may be used to deem a transaction to be a failure.

Transaction	Time out (sec)	Entity using timeout	Rationale
canBotEnter ->	About 7	Charge Manager	About 4 comm transactions turn off power supply
botCanEnter ->	About 8	Gang Manager	About 2 comm transactions move bot
botIsAtContact ->	About 338	Charge Manager	About 2 comm transactions to gang manager
botHasQuick Charge			Max charge time = N seconds
canBotLeave ->	About 7	Charge Manager	About 4 comm transactions turn charger off
botCanLeave ->	About 6	Gang Manager	Move bot
botHasLeft Time to turn off a bot	About 5	Gang Manager	off cycle About 1 each for comm
Time to charge a bot	About 338	Gang Manager	About 2 comm transactions max charge time = N seconds

When there is a power supply failure a message may be relayed from the gang manager 290G. During a power supply failure the bots 110 may be allowed to leave the charging stations 290 even if the bots have not received a minimum amount of charge. The charge manager 299 may use the information from the gang manager 290G in conjunction with, for example, the state of the bot 110 or bot controller's 298 conversation with the gang manager 290G to complete any pending charging cycles, and mark the charging station(s) 290 connected to the failed power supply as inoperable. In this case the gang manager 290G and or charger manager 299 may find other available charging stations 290 and communicate with the level manager 297 for routing the bots 110 that did not receive the minimum amount of charge to these available charging stations 290 (e.g. without impeding ingress/egress to the respective multilevel vertical conveyors 150 at the locations of the available charging stations 290).

With respect to other exemplary communications within the bot charging system, the bots 110 may communicate with a respective bot controller 298 to indicate a simulated bot's voltage and that the bot has left (or arrived at) a charging station 290. The bot controller 298 may communicate with a respective bot 110 a post-charge voltage that may be valid only during a simulation. The charge manager 299 may communicate with the charging stations 290 to ensure the charging station is off so a bot 110 can enter or leave the charging station 290. The charge manager 299 may also indicate when gang charging can start or resume, indicate that a bot has left a charging station and to resume

charging and to enable/disable one or more charging stations. The gang manager 290G may indicate the charging station is off so that the bot can move on to or off the charging station, that the bot has received a quick charge, and a state of the charging station 290 (e.g. whether the charging station is inoperable, off, in constant current mode, in constant voltage mode, etc.).

In the embodiments, the bot controller 298 may be configured to allocate the charging stations 290 using reservations (e.g. each bot that is to access a particular charging station "reserves" or allocates that charging station so no other bots are able to access it during the reservation period). When a bot 110 with a reservation accesses a charging station 290 it receives a charge and when complete the bot 110 requests to release (e.g. un-reserve) the charging station 290 so that the charging station 290 can be reserved for other bots 110. FIG. 8 illustrates a transaction state diagram for a charging sequence in which a reservation is held. For example, before the bot enters the charging station 290 a request is made for the bot to enter the charging station. If there is no bot present at the charging station 290 the request may be granted and the bot enters the charging station 290. If only a transfer of items to/from a multilevel vertical conveyor 150 is being made, the transfer may take place and a request for release of the charging station 290 may be sent by the bot 110 and after the release a notification that the bot 110 has left may be made. Where charging is to occur (in addition to or in lieu of a transfer of items to/from the multilevel vertical conveyor 150) charging may occur when the bot 110 is in the charging station 290. A check may be made as to whether the bot 110 has received a quick charge. If the bot 110 has received a quick charge the bot 110 is able to leave the charging station 290 and makes a request to release the charging station 290. Once the charging station 290 is released the bot 110 exits the charging station 290 and an indication that the bot 110 has left is made.

FIG. 9 illustrates exemplary class hierarchies and dependencies with respect to communication between the charge manager 299 and the bots 110.

In the embodiments the operational state of the charging station within a vestibule 130V may be linked in any suitable manner to an operational state of a corresponding multilevel vertical conveyor 150. Referring to FIG. 10, for exemplary purposes only four vestibules 130V1-130V4 of a single pick floor level are shown where each vestibule 130V1-130V4 has two charging stations 290. It is noted that in the embodiments the storage and retrieval system may have any suitable number of vestibules each having any suitable number of charging stations. Each vestibule is served by a respective multilevel vertical conveyor 150-1, 150-2, 150-3, 150-4. Each of these multilevel vertical conveyors also serves other vestibules vertically stacked above and/or below a respective one of the vestibules 130V1-130V4.

Upon startup of the level manager 297, with respect to charging operations of the bots 110, the charge manager 299

knows the structural information about each charging station 290 (e.g. where they are located and which multilevel vertical conveyor is associated with the respective charging stations). The charge manager 299 may communicate with each charging station 290 to obtain, for example, an operational status of the charging stations 290. The bot controller 298 of the level manager 297 may communicate with the bots 110 for issuing commands or jobs (e.g. to transfer case units 101) to the bots 110.

When a bot, such as bot 110X, needs to be charged, whether in conjunction with the transfer of a case unit 101 to/from a multilevel vertical conveyor 150-1, 150-2, 150-3, 150-4 or not, the bot may send a message to a vestibule manager 296 for determining which vestibule 130V1-130V4 the bot is to be directed to. In the embodiments the vestibule manager 296 may be part of the level manager 297 or, the vestibule manager 296 may be included in any suitable controller of the storage and retrieval system. If the charging of bot 110X is not in connection with a case unit 101 transfer, the vestibule manager 296 may direct the bot 110X to a vacant or unallocated operational charging station 290 in a nearest "online" or operational vestibule 130V1-130V4. If the charge of the bot 110X is in conjunction with a transfer of case units 101 to/from a multilevel vertical conveyor 150-1, 150-2, 150-3, 150-4, the vestibule manager 296 may communicate with the vestibule (which for exemplary purposes may be vestibule 150-3) at which the bot 110X is to transfer the case units 101 to verify that the charging stations 290 of that vestibule are operational. At least one of the charging stations at, for example, vestibule 150-3 may be reserved for the bot 110X as described above. If however, one or more of the charging stations for the vestibule 150-3 is determined as being inoperable a suitable controller of the storage and retrieval system such as control server 120 may inform the level manager 297 and/or the vestibule manager 296 that the vestibule 150-3 is "offline" or inoperable such that no case units 101 can be transferred to the multilevel vertical conveyor 150-3 nor can bots 110 be charged at other operational charging stations 290 of offline vestibule 130V3. The level manager 297, with information provided by the vestibule manager 296, may communicate with bot 110X and direct the bot 110X to an available charging station 290 of the next available vestibule 130V1-130V4 for transferring the item 101 while simultaneously charging the bot 110X.

In the embodiments, vestibules vertically stacked above and/or below vestibule 130V3 may still be able to charge bots 110 and transfer case units 101 to the multilevel vertical conveyor 150-3. In the embodiments, because the charging stations 290 of vestibule 130V3 may be powered by the same power supply 290P (FIG. 3) as charging stations of vestibules stacked above and/or below vestibule 130V3, all of the vestibules associated with the power supply of vestibule 130V3 may be designated as offline for charging and item 101 transfers. Still, the vestibule 130V3 may remain "online" so that bots can charge and transfer case units 101 at the remaining operational charging station(s) 290 of the vestibule 130V3. The vestibule 130V3 may also remain online with respect to item transfers such that, if bot 110X has a sufficient charge, the bot 110X can transfer items at a location of the inoperable charging station 290 and then move on to be charged at a next available charging station 290 at the same vestibule 130V3 or different vestibule 130V1, 130V2, 130 V4.

Referring to FIGS. 11-13 and also to FIGS. 2B and 6 the bot controller 298 and charge manager 299 may interact with each other for reserving resources within the storage and retrieval system 100. It is noted that FIG. 12 illustrates a

state chart diagram for bot controller 298 interaction for reserving resources of the storage and retrieval system and FIG. 13 illustrates a sequence diagram of how each reservation request for a charging station translates into a reservation of the charging station. As an example, bot 110X may be designated by bot controller 298 for charging at charging station 290B of vestibule 130V. Travel of the bot 110X may be defined by waypoints 1101-1108 within the storage and retrieval system 100. As the bot travels the bot controller 298 of level manager 297 may look to each waypoint for reserving a resource of the storage and retrieval system to allow the bot 110X to travel along a predetermined course. Prior to or during reservation of the resources by the bot controller 298 the charge manager may confirm that a desired charging resource and any intervening charging resources are available or will be available at the time they are needed by the bot 110X. If the charging resources are available the bot controller 298 continues with planning the predetermined route, which in this example, is charging station 290B. If one or more of the charging resources and intervening charging resources are not or will not be available the route of the bot 110X may be re-routed to an available charging resource (and corresponding multilevel vertical conveyor). In this example, the bot 110X may start in picking aisle 130A7 for picking a case unit 101. Picking aisle 103A7 may be reserved by the bot 110X while the bot 110 is located within the aisle 130A7. As the bot is travelling out of the picking aisle 130A7 a request to reserve an entrance onto guide line or travel path 130L4 is made and granted. Once on the guide line 130L4 a reservation is requested for travelling along vestibule 130V/multilevel vertical conveyor 150 entrance guide line or path 130C1 and is granted. The bot controller looks to the next waypoint 1107 and requests a reservation for the multilevel vertical conveyor transfer location 290T1 and if the availability of the transfer location 290T1 is verified the request is granted. The bot controller may check to see if the transfer location 290T1 is also a charging resource, which it is, and requests a reservation for charging station 290A and if the charging station is available the request is granted. Even though the bot 110X will not transfer case units 101 or charge at transfer location 290T1/charging station 290A, the bot 110X passes through these areas on its way to charging station 290B and reserves transfer location 290T1/charging station 290A to ensure passage to charging station 290B. The bot controller also looks to waypoint 1108 to reserve multilevel vertical conveyor transfer location 290T2 and if the availability of the transfer location 290T2 is verified the request is granted. The bot controller 298 may check to see if the transfer location 290T2 is also a charging resource, which it is, and requests a reservation for charging station 290B and if the charging station is available the request is granted. After the bot passes through transfer location 290T1 and charging station 290A the bot controller releases transfer location 290T1 and charging station 290A so these resources are available to other bots 110. While the bot 110X is at the transfer location 290T2, the bot 110X may transfer case units 101 between the bot 110X and the conveyor shelf 250 while simultaneously receiving a charge from charging station 290B. Upon reaching a quick charge level the bot 110X the bot controller 298 is notified of the quick charge being substantially complete and requests that the bot 110X leave the transfer location 290T2 and charging station 290B. The bot 110X verifies that it has left the transfer location 290T2 and charging station 290B and the bot controller releases the transfer location 290T2 and charging station 290B so they become available resources for other bots 110.

Referring again to FIGS. 6 and 10, as described above, when a charging station 290 becomes inoperable the storage and retrieval system is configured to re-route a bot 110 to another operable charging station 290. In one exemplary embodiment when a charging station 290 becomes inoperable all affected bot controllers 298 are notified for taking appropriate action such as, for example, canceling jobs directed to the inoperable charging station. It is noted that in one exemplary embodiment the affected bot controller 298 may be bot controller for pick floor levels having charging stations powered by the same power supply as the inoperable charging station. Any bot jobs not yet scheduled (e.g. that have already been re-routed) may not be allocated to the inoperable charging stations 290 or their corresponding multilevel vertical conveyors 150 for at least the pick floor level on which the inoperable charging station 290 is located.

Referring again to FIG. 2B in the embodiments the controller 150C may be used to initiate and monitor charging of the bots 110. In one example the gang manager 290G may start the power supply 290P and the controller 150C may enable the power supply output. The controller 150C may monitor an operational status of the power supply and alert the gang manager 290G if there is any inoperability of the power supply 290P. The controller 150C may wait a predetermined amount of time before monitoring the power supply 290P (e.g. to avoid any inrush power spikes) and maintain a record of the current of the power supply and monitors the current for a condition where the current drops below a predetermined level. The gang manager 290G may turn off the power supply for any suitable reason (such as e.g. when a bot wants to enter or leave a charging station) and the controller 150C may turn off the power to the chargers and direct the bots 110 accordingly.

In a first aspect of the embodiments, a charging system for autonomous transport vehicles in a warehouse storage and retrieval system is provided. The charging system includes at least one charging contact disposed on each pick floor level of the storage and retrieval system, each of the at least one charging contact being located at a transfer station, at least one power supply configured to supply power to the at least one charging contact and a first controller in communication with the transfer station and being configured to communicate information relating to a transfer of items between the transfer station and a predetermined one of the autonomous transport vehicles and to apply power from the power supply to the at least one charging contact for charging the predetermined autonomous transport vehicle corresponding to the transfer and located at the multilevel vertical conveyor transfer station, wherein the first controller is configured to supply power to the charging contacts for charging the predetermined autonomous transport vehicle simultaneously with the predetermined autonomous transport vehicle exchanging items at the transfer station.

In accordance with a first sub-aspect of the first aspect of the embodiments, the charging system further comprising a capacitor disposed on the autonomous transport vehicle and a receptacle configured to interface with the at least one charging contact where the engagement is configured to transfer power to the capacitor.

In accordance with the first sub-aspect of the first aspect of the embodiments, the receptacle includes a contact pad and the at least one charging contact includes actuable members configured to engage the contact pad.

In accordance with the first aspect of the embodiments, each pick floor of the storage and retrieval system includes at least one vestibule extending from a transfer deck and

located adjacent a respective multilevel vertical conveyor, wherein at least one charging contact is located in each of the at least one vestibule.

In accordance with the first aspect of the embodiments, the transfer station includes a multilevel vertical conveyors and the operation of the at least one charging contact and an associated multilevel vertical conveyor are linked such that when the at least one charging contact is inoperable the controller deems the multilevel vertical conveyor inoperable at least for the pick floor level on which the at least one charging contact is located.

In accordance with the first aspect of the embodiments, the first controller is configured to control operations of the power supply and the multilevel vertical conveyor.

In accordance with a second sub-aspect of the first aspect of the embodiments, the charging system further comprises a second controller configured to effect a charge cycle of each autonomous transport vehicle located on at least one pick floor level simultaneously with the exchange of items with the multilevel vertical conveyor.

In accordance with a second aspect of the embodiments, a storage and retrieval system is provided. The storage and retrieval system includes, at least one autonomous transport vehicle, at least one transfer station having an operable and inoperable state where in the operable state the at least one transfer station is configured to allow transfer of items from and to the at least one autonomous transport vehicle, at least one charging station disposed on each pick floor level of the storage and retrieval system, each of the at least one charging contact being located at a respective one of the at least one transfer station, at least one power supply configured to supply power to the at least one charging contact, and a controller in communication with the transfer station and being configured to communicate information relating to a transfer of items between the transfer station and a predetermined one of the autonomous transport vehicles and to apply power from the power supply to the at least one charging station for charging the at least one autonomous transport vehicle located at the transfer station, wherein the controller is configured to supply power to the charging station for charging a predetermined autonomous transport vehicle corresponding to the transfer of items simultaneously with the predetermined autonomous transport vehicle exchanging items related to the transfer at a predetermined transfer station when the predetermined transfer station is in the operative state and to supply power to the charging station for charging another of the at least one autonomous vehicles located at the predetermined transfer station when the predetermined transfer station is in the inoperative state.

In accordance with the second aspect of the embodiments, the storage and retrieval system further includes at least one multilevel conveyor and at least one pick floor level having storage locations, at least one vestibule and a transfer deck connecting the storage locations with the at least one vestibule, each of the at least one vestibules having at least one of the at least one transfer station configured to provide access to a respective one of the at least one multilevel vertical conveyor, wherein the controller is configured to control operations of at least one of the at least one multilevel vertical conveyors and operations of at least one charging station located in vestibules associated with the respective multilevel vertical conveyor.

In accordance with the second aspect of the embodiments, a level controller is connected to each pick floor level and configured to control storage and retrieval operations of the respective level, the level controller being further configured to link operations of the at least one multilevel vertical

## 21

conveyors with associated charging stations such that access to the at least one multilevel vertical conveyor is prevented when one or more of the associated charging stations is inoperable.

In accordance with a first sub-aspect of the second aspect of the embodiments, the storage and retrieval system includes at least one power supply, the at least one power supply being commonly connected to charging stations of vertically adjacent ones of the at least one pick floor level.

In accordance with the first sub-aspect of the second aspect of the embodiments, the charging stations commonly connected to the at least one power supply comprising a two by two array of charging stations where a first two of the charging stations in the array are located on a first pick floor level and a second two of the charging stations in the array are located on a second pick floor level, the first two of the charging stations and the second two of the charging stations being vertically stacked one above the other.

In accordance with the first sub-aspect of the second aspect of the embodiments, each vestibule includes at least two charging stations arranged on a common linear path.

In accordance with the first sub-aspect of the second aspect of the embodiments, the transfer deck includes an array of autonomous transport vehicle travel paths, the array including longitudinal travel paths providing access to the storage locations and the at least one vestibule and transverse travel paths providing shunts between the longitudinal travel paths.

In accordance with the second sub-aspect of the second aspect of the embodiments, the controller is configured to reserve one or more of the charging stations for allowing an autonomous transport vehicle access to the one or more of the at least two charging stations.

In accordance with the second aspect of the embodiments, the controller is configured to re-route an autonomous transport vehicle destined for a charging station at a first vestibule to a charging station at another vestibule when the charging station at the first vestibule is inoperable.

In accordance with the second aspect of the embodiments, when in the unallocated state the transfer station is not configured to allow transfer of items from and to the at least one autonomous transport vehicle.

It should be understood that the embodiments disclosed herein can be used individually or in any suitable combination thereof. It should also be understood that the foregoing description is only illustrative of the embodiments. Various alternatives and modifications can be devised by those skilled in the art without departing from the embodiments. Accordingly, the present embodiments are intended to embrace all such alternatives, modifications and variances that fall within the scope of the appended claims.

What is claimed is:

**1.** A method comprising:

providing at least one autonomous transport vehicle;  
 providing at least one transfer station having an allocated and unallocated state where in the allocated state the at least one transfer station allows transfer of items from and to the at least one autonomous transport vehicle;  
 providing at least one charging station on each pick floor level of a storage and retrieval system, each of the at least one charging station being located at a respective one of the at least one transfer station;  
 providing at least one power supply configured to supply power to the at least one charging station;  
 communicating, with a controller in communication with at least one of the at least one charging station or the at least one autonomous transport vehicle, information

## 22

related to a transfer of items between a predetermined at least one transfer station and a predetermined one of the at least one autonomous transport vehicle; and  
 with the controller, applying power from the at least one power supply to the at least one charging station for charging the at least one autonomous transport vehicle located at the at least one transfer station, wherein the controller supplies power to the at least one charging station for charging the predetermined one of the at least one autonomous transport vehicle corresponding to the transfer of items with the predetermined one of the at least one autonomous transport vehicle transferring the items at the predetermined at least one transfer station with the predetermined at least one transfer station in the allocated state and communicating with another of the at least one autonomous transport vehicle and identifying an unallocated time period with the predetermined at least one transfer station in the unallocated state for charging the other one of the at least one autonomous transport vehicle at the at least one charging station of the predetermined at least one transfer station in the unallocated state.

**2.** The method of claim 1, further comprising:  
 providing at least one vertical lift within the storage and retrieval system;

providing at least one pick floor level having storage locations, at least one vestibule and a transfer deck connecting the storage locations with the at least one vestibule, each of the at least one vestibule having at least one of the at least one transfer station providing access to a respective one of the at least one vertical lift; and

controlling operations, with the controller, of at least one of the at least one vertical lift and operations of at least one charging station located in vestibules associated with the respective vertical lift.

**3.** The method of claim 2, further comprising controlling, with a level controller connected to each pick floor level, storage and retrieval operations of a respective level, and linking, with the level controller, operations of the at least one vertical lift with associated charging stations such that access to the at least one vertical lift is prevented when one or more of the associated charging stations is inoperable.

**4.** The method of claim 2, wherein the at least one power supply is commonly connected to charging stations of vertically adjacent ones of the at least one pick floor level.

**5.** The method of claim 4, wherein the charging stations are commonly connected to the at least one power supply comprising a two by two array of charging stations where a first two of the charging stations in the array are located on a first pick floor level and a second two of the charging stations in the array are located on a second pick floor level, the first two of the charging stations and the second two of the charging stations being vertically stacked one above the other.

**6.** The method of claim 2, further comprising providing each vestibule with at least two charging stations and arranging the at least two charging stations on a common linear path.

**7.** The method of claim 2, further comprising providing the transfer deck with an array of autonomous transport vehicle travel paths, the array including longitudinal travel paths providing access to the storage locations and the at least one vestibule and transverse travel paths providing shunts between the longitudinal travel paths.

**8.** The method of claim 2, further comprising reserving, with the controller, one or more of the at least one charging

23

station for allowing one of the at least one autonomous transport vehicle access to the one or more of the at least one charging station.

9. The method of claim 2, further comprising re-routing, with the controller, one of the at least one autonomous transport vehicle destined for a charging station at a first vestibule to a charging station at another vestibule when the charging station at the first vestibule is inoperable.

10. The method of claim 2, wherein in the unallocated state the at least one transfer station does not allow the transfer of items from and to the at least one autonomous transport vehicle.

11. The method of claim 2, wherein the other of the at least one autonomous transport vehicle traverses from a position on a transfer deck or in a picking aisle to the predetermined at least one transfer station along at least one shunt path between the position on the transfer deck or in the picking aisle and the predetermined at least one transfer station and, wherein the other of the at least one autonomous transport vehicle enters the at least one vestibule from the at least one shunt path.

12. The method of claim 1, wherein the other of the at least one autonomous transport vehicle traverses from a position on a transfer deck or in a picking aisle to the predetermined at least one transfer station along at least one shunt path between the position on the transfer deck or in the picking aisle and the predetermined at least one transfer station.

13. The method of claim 12, wherein the other of the at least one autonomous transport vehicle is in an idle state at the position on the transfer deck or in the picking aisle.

14. A warehouse storage and retrieval system comprising at least one autonomous transport vehicle;

at least one transfer station having an allocated and unallocated state where in the allocated state the at least one transfer station allows transfer of items from and to the at least one autonomous transport vehicle;

at least one charging station disposed on each pick floor level of the warehouse storage and retrieval system, each of the at least one charging station being located at a respective one of the at least one transfer station; at least one power supply configured to supply power to the at least one charging station; and

a controller communication with at least one of the at least one charging station or the at least one autonomous transport vehicle, where the controller is configured to communicate information related to a transfer of items between a predetermined at least one transfer station and a predetermined one of the at least one autonomous transport vehicle,

apply power from the at least one power supply to the at least one charging station for charging the at least one autonomous transport vehicle located at the at least one transfer station, wherein the controller supplies power to the at least one charging station for charging the predetermined one of the at least one autonomous transport vehicle corresponding to the transfer of items with the predetermined one of the at least one autonomous transport vehicle transferring the items at the predetermined at least one transfer station with the predetermined at least one transfer station in the allocated state, and

communicate with another of the at least one autonomous transport vehicle to identify an unallocated time period with the predetermined at least one transfer station in the unallocated state for charging the other of the at least one autonomous transport vehicle at the at least

24

one charging station of the predetermined at least one transfer station in the unallocated state.

15. The warehouse storage and retrieval system of claim 14, further comprising:

at least one vertical lift within the storage and retrieval system;

at least one pick floor level having storage locations;

at least one vestibule; and

a transfer deck connecting the storage locations with the at least one vestibule, each of the at least one vestibule having at least one of the at least one transfer station configured to provide access to a respective one of the at least one vertical lift;

wherein the controller is configured to control operations of at least one of the at least one vertical lift and operations of at least one charging station located in vestibules associated with the respective vertical lift.

16. The warehouse storage and retrieval system of claim 15, further comprising a level controller connected to each pick floor level, the level controller being configured to control storage and retrieval operations of a respective level, and

link operations of the at least one vertical lift with associated charging stations such that access to the at least one vertical lift is prevented when one or more of the associated charging stations is inoperable.

17. The warehouse storage and retrieval system of claim 15, wherein the at least one power supply is commonly connected to charging stations of vertically adjacent ones of the at least one pick floor level.

18. The warehouse storage and retrieval system of claim 17, wherein the charging stations are commonly connected to the at least one power supply comprising a two by two array of charging stations where a first two of the charging stations in the array are located on a first pick floor level and a second two of the charging stations in the array are located on a second pick floor level, the first two of the charging stations and the second two of the charging stations being vertically stacked one above the other.

19. The warehouse storage and retrieval system of claim 15, wherein each at least one vestibule includes at least two charging stations arranged on a common linear path.

20. The warehouse storage and retrieval system of claim 15, wherein the transfer deck includes an array of autonomous transport vehicle travel paths, the array including longitudinal travel paths providing access to the storage locations and the at least one vestibule and transverse travel paths providing shunts between the longitudinal travel paths.

21. The warehouse storage and retrieval system of claim 15, wherein the controller is configured to reserve one or more of the at least one charging station for allowing one of the at least one autonomous transport vehicle access to the one or more of the at least one charging station.

22. The warehouse storage and retrieval system of claim 15, wherein the controller is configured to re-route one of the at least one autonomous transport vehicle destined for a charging station at a first vestibule to a charging station at another vestibule when the charging station at the first vestibule is inoperable.

23. The warehouse storage and retrieval system of claim 15, wherein in the unallocated state the at least one transfer station does not allow transfer of items from and to the at least one autonomous transport vehicle.

24. The warehouse storage and retrieval system of claim 15, wherein the other of the at least one autonomous transport vehicle traverses from a position on a transfer deck or in a picking aisle to the predetermined at least one transfer

station along at least one shunt path between the at least one autonomous vehicle position on the transfer deck or in the picking aisle and the predetermined at least one transfer station and, wherein the other of the at least one autonomous transport vehicle enters the at least one vestibule from the at least one shunt path. 5

25. The warehouse storage and retrieval system of claim 14, wherein the other of the at least one autonomous transport vehicle traverses from a position on a transfer deck or in a picking aisle to the predetermined at least one transfer station along at least one shunt path between the at least one autonomous vehicle position on the transfer deck or in the picking aisle and the predetermined at least one transfer station. 10

26. The warehouse storage and retrieval system of claim 15 15  
25, wherein the other of the at least one autonomous transport vehicle is in an idle state at the position on the transfer deck or in the picking aisle.

\* \* \* \* \*