



US009745167B2

(12) **United States Patent**
Niu

(10) **Patent No.:** **US 9,745,167 B2**

(45) **Date of Patent:** **Aug. 29, 2017**

- (54) **REEL WITH BUILT IN PALLET**
- (71) Applicant: **Sonoco Development, Inc.**, Hartsville, SC (US)
- (72) Inventor: **Xiaokai Niu**, Hartsville, SC (US)
- (73) Assignee: **Sonoco Development, Inc.**, Hartsville, SC (US)
- (*) Notice: Subject to any disclaimer, the term of this patent is extended or adjusted under 35 U.S.C. 154(b) by 0 days.

(56) **References Cited**

U.S. PATENT DOCUMENTS

2,834,507 A *	5/1958	Metzler	B65D 21/0209
			206/509
6,533,216 B1 *	3/2003	Bumgarner	B65H 75/14
			242/118.41
9,278,827 B2 *	3/2016	Niu	B65H 75/14
2006/0086863 A1 *	4/2006	Couchey	B65H 75/18
			242/610.6
2009/0084887 A1 *	4/2009	Aiston	B65H 75/148
			242/587.2

FOREIGN PATENT DOCUMENTS

DE	2033923 A1 *	2/1971	B21C 47/28
----	--------------	--------------	------------

* cited by examiner

- (21) Appl. No.: **15/002,645**
- (22) Filed: **Jan. 21, 2016**
- (65) **Prior Publication Data**

US 2016/0152436 A1 Jun. 2, 2016

Related U.S. Application Data

- (63) Continuation of application No. 13/591,630, filed on Aug. 22, 2012, now Pat. No. 9,278,827.

- (51) **Int. Cl.**
- B65H 75/18** (2006.01)
- B65H 75/14** (2006.01)
- B65G 57/26** (2006.01)

- (52) **U.S. Cl.**
- CPC **B65H 75/185** (2013.01); **B65G 57/26** (2013.01); **B65H 75/14** (2013.01); **B65H 75/18** (2013.01); **B65H 2701/534** (2013.01)

- (58) **Field of Classification Search**
- CPC B65H 75/14; B65H 75/18; B65H 75/185; B65H 75/40; B65H 75/44; B65H 49/328; B65H 67/066; B65H 2701/534; B65G 57/26

See application file for complete search history.

Primary Examiner — William E Dondero
(74) *Attorney, Agent, or Firm* — Miller, Matthias & Hull LLP

(57) **ABSTRACT**

A cable reel for holding a cable wound thereon that includes a cylindrical drum having a longitudinal axis, a first end, and a second end spaced from the first end. The cable reel also includes a first flange that is coupled to the first end of the cylindrical drum and a second flange that is coupled to the second end of the cylindrical drum. The cable reel further includes a spacer that extends axially outward from the first flange. The spacer is configured to support the reel with the first flange spaced above a support surface when the longitudinal axis of the reel is in a substantially vertical orientation and with the reel being supported on the support surface by the spacer.

8 Claims, 6 Drawing Sheets

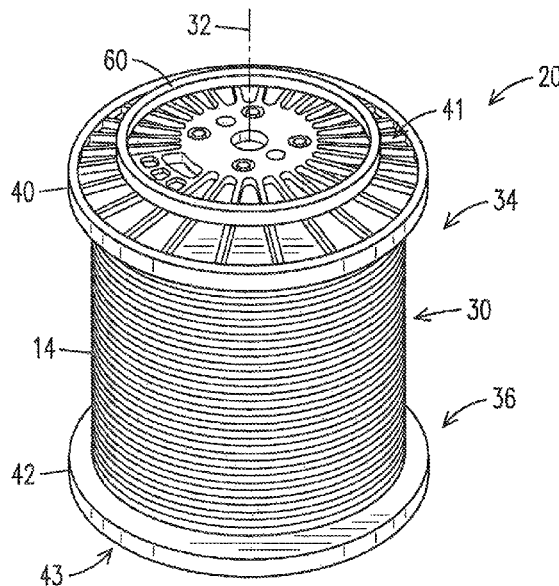

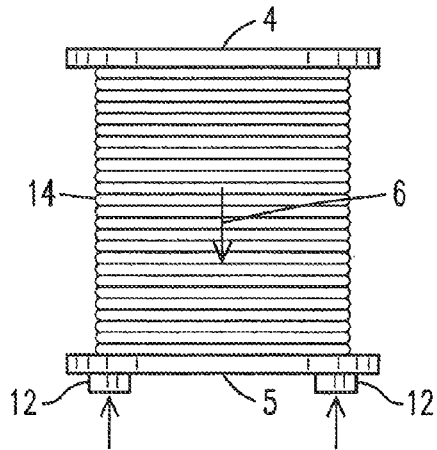

FIG. 1
PRIOR ART

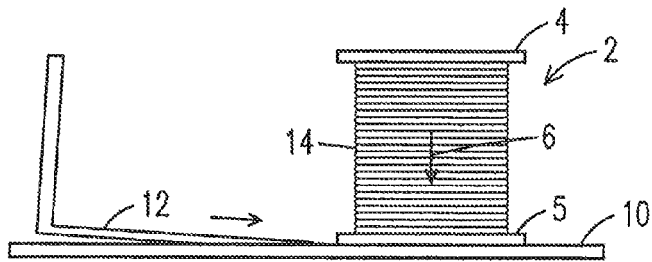

FIG. 2A
PRIOR ART

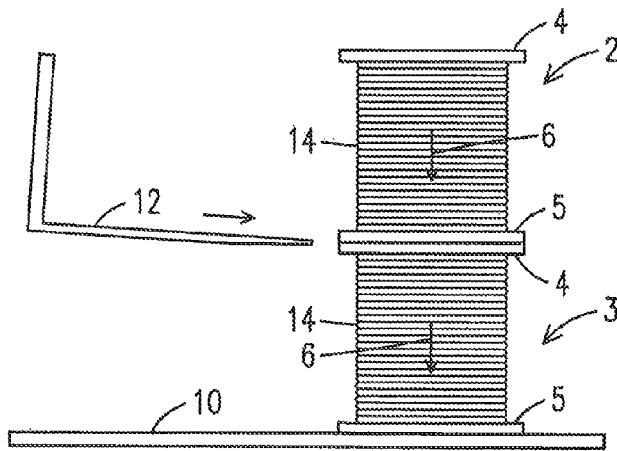

FIG. 2B
PRIOR ART

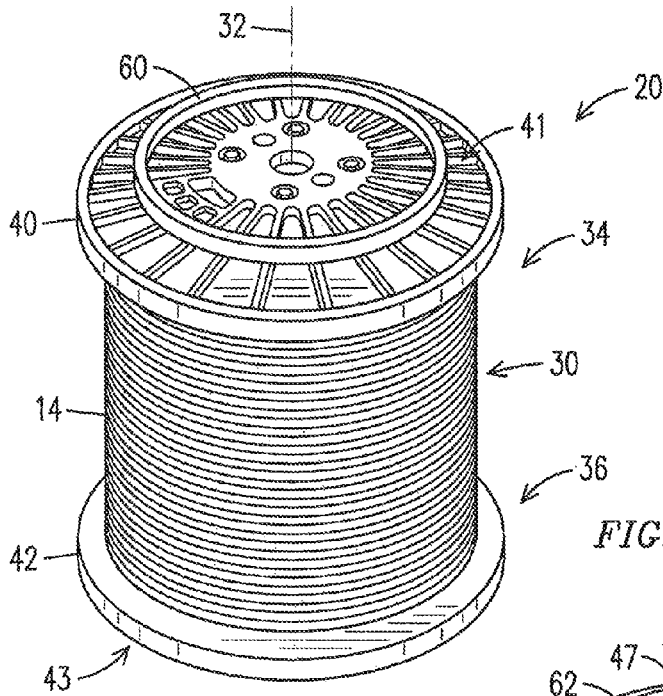

FIG. 3

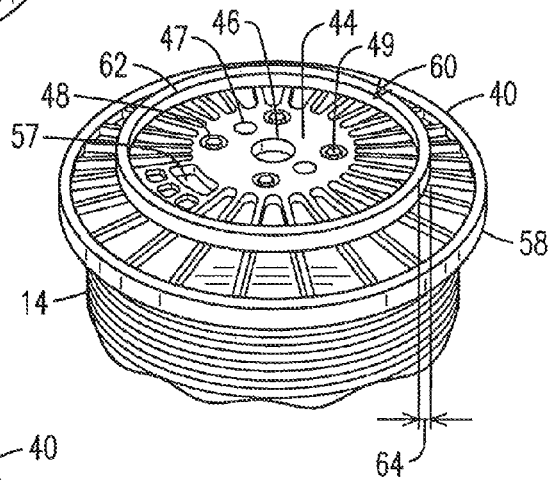

FIG. 4A

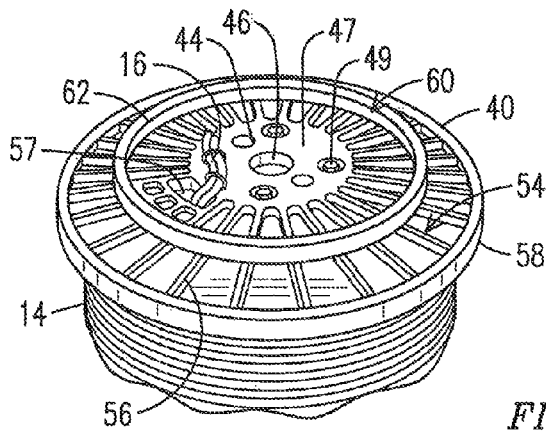

FIG. 4B

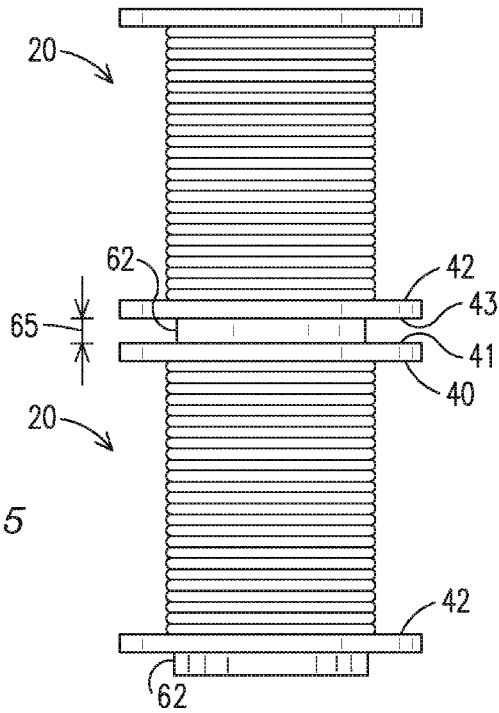

FIG. 5

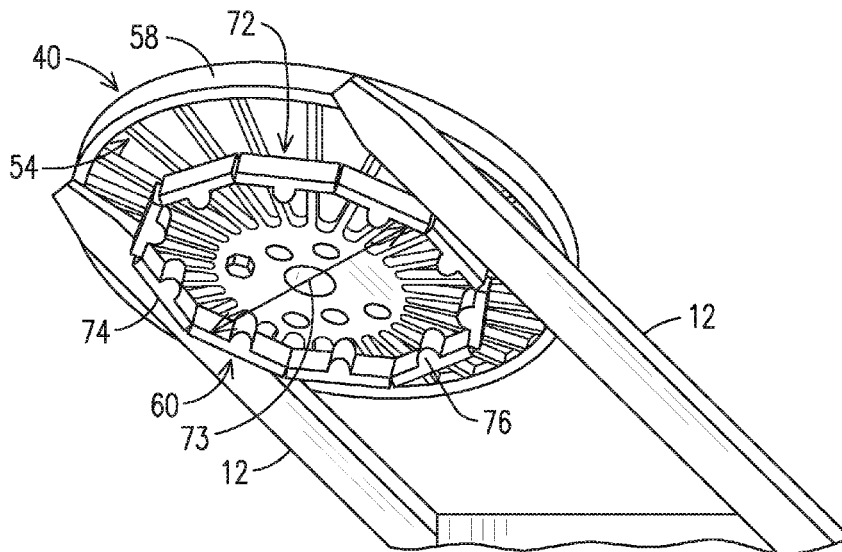
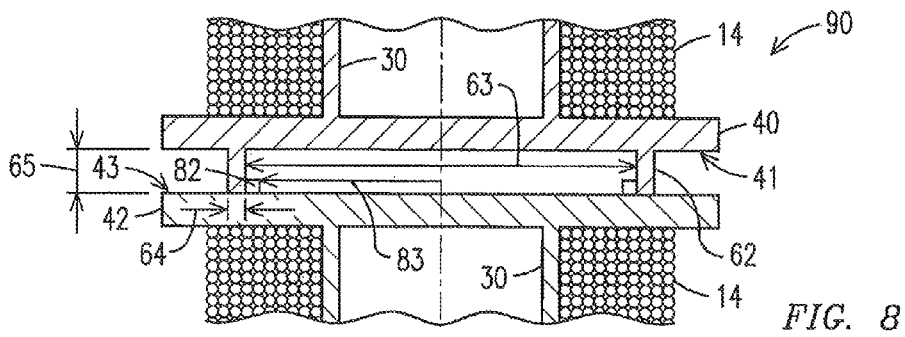
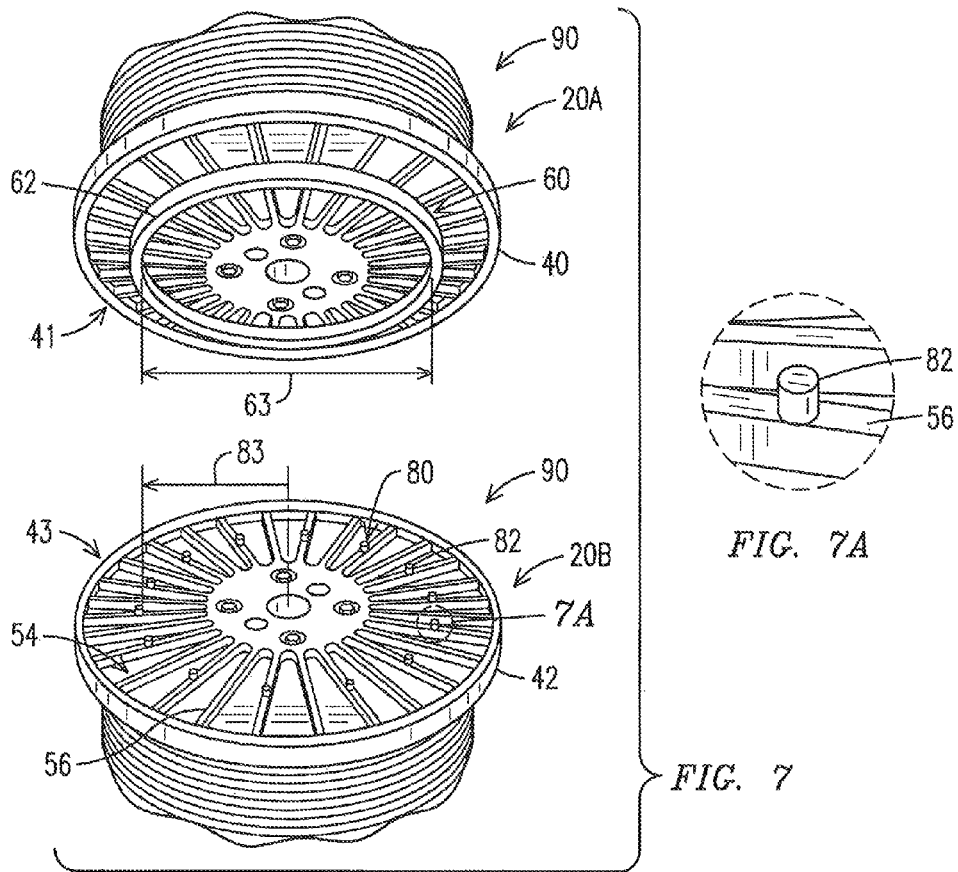
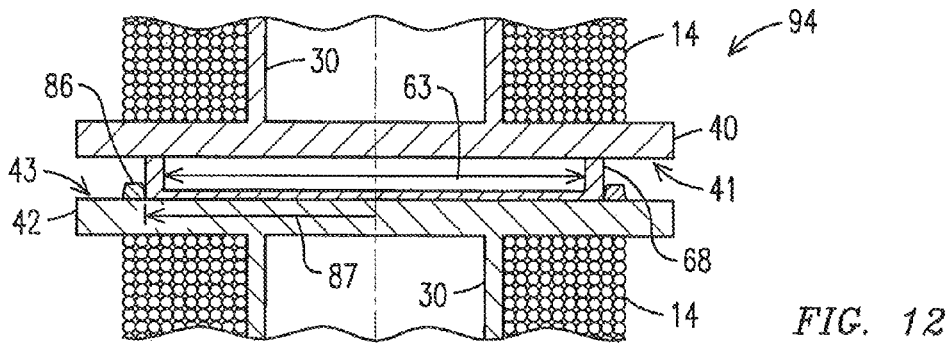
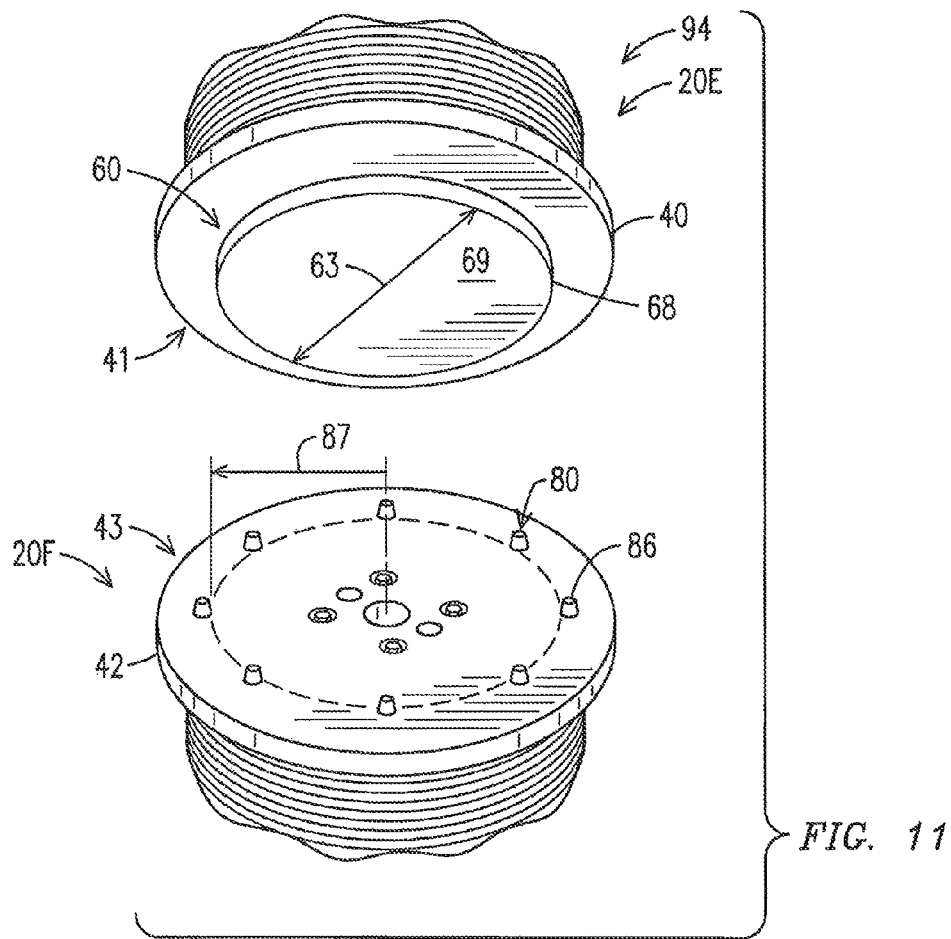

FIG. 6





1

REEL WITH BUILT IN PALLETCROSS REFERENCE TO RELATED
APPLICATION

This application is a continuation of U.S. application Ser. No. 13/591,630, filed Aug. 22, 2012. U.S. application Ser. No. 13/591,630 is incorporated here by reference in its entirety to provide continuity of disclosure.

TECHNICAL FIELD

This disclosure relates generally to cable reels for holding cables wound thereon, and more particularly to apparatus and systems for stacking upright cable reels on top of each other.

BACKGROUND

FIG. 1 is a schematic representation of a cable reel 2 as typically found in the prior art, and which includes a barrel portion (not shown) with flanges 4, 5 attached at both ends. A cable 14 is typically wrapped around the barrel portion and in between the inner surfaces of the flanges 4, 5 while the reel 2 is rotatably mounted on a horizontal spindle installed through spindle holes in the center of the flanges 4, 5. After the cable has been wrapped around the barrel portion, the cable reel 2 is typically turned upright for storage and transportation to the location of intended use, where it is once again mounted onto a spindle and rotated as the cable 14 is fed from the reel 2. While oriented in the vertical and upright position, however, the cable reel 2 must be stackable on top of a lower cable reel 3 of equal or greater size (see FIG. 2B). And whether isolated or stacked, the upright cable reel 2 must also be able to tolerate lateral loadings and forces which may be experienced during storage and transportation (e.g. within the cargo area of a truck) that would otherwise cause the cable reel to tip and fall.

A cable reel 2 that is loaded with wire or cable 14 can be quite heavy, with a significant weight 6 that generally requires a fork truck having forks 12 to lift and move the loaded cable reel. With loaded cable reels 2, it is desirable that the forks 12 be positioned completely under the lower flange 5 of the upright cable reel 2 and towards the outer portion of the flange, but still underneath the boundary of the wrapped cable 14 (as shown in FIG. 1). This ensures that the elevated reel 2 has a wide base to protect against tipping and falling, and with the weight 6 of the cable 14 passing directly downward through the thickness of the flange 5 to the supporting forks 12, and not laterally across the expanse of the flange. If the forks 12 are too far apart, so as to leave the center portion of the flange 5 largely unsupported, the flange could bow or sag downwards in the center under the weight 6 of the cable 14 and eventually crack and fail.

It can be problematic, however, to correctly position the forks 12 under the lower flange 5 of the cable reel 2 when the bottom face of the lower flange 5 is contacting and flush with the ground surface 10 (FIG. 2A), or stacked flush on top of the upper flange 4 of another cable reel 3 (FIG. 2B). This is because the driver of the fork truck, who usually works alone, may have difficulty forcing the forks 12 in between the floor 10 and the bottom flange 5, or in between the top flange 4 of the bottom reel 3 and the bottom flange 5 of the top reel 2 to pick up the reel 2.

What is needed is a system for better supporting an upright cable reel on a ground surface or on the upper flange

2

of a lower cable reel that allows the forks of a fork lift to be properly positioned for lifting and moving the cable reel. Moreover, the system must still provided the support necessary to avoid tipping and falling during storage and stacked transportation (e.g. such as being stacked within the cargo area of a truck, etc.)

SUMMARY

Briefly described, a cable reel for holding a cable thereon includes a cylindrical drum having a longitudinal axis, a first end, and a second end spaced from the first end. The cable reel also includes a first flange that is coupled to the first end of the cylindrical drum and a second flange that is coupled to the second end of the cylindrical drum. The cable reel further includes a spacer that extends axially outward from the first flange. The spacer is configured to support the reel with the first flange spaced above a support surface when the longitudinal axis of the reel is in a substantially vertical or upright orientation and with the reel being supported on the support surface by the spacer.

In another representative embodiment, the cable reel includes a cylindrical drum having ends and flanges extending radially outwardly from the ends of the drum, with each flange having an outer face. The cable reel also includes a spacer that projects outwardly from the outer face of one of the flanges, and which is configured to support the reel on a surface with the outer face of the one flange being spaced from the surface.

In another representative embodiment, a system for stacking a plurality of cable reels that includes a first cable reel and a second cable reel. The first cable reel includes a first cylindrical drum having a first longitudinal axis, a first proximal flange coupled to the first cylindrical portion at a first proximal end, and a first distal flange coupled to the first cylindrical portion at a first distal end spaced from the first proximal end. Similarly, the second cable reel includes a second cylindrical drum having a second longitudinal axis, a second proximal flange coupled to the second cylindrical portion at a second proximal end, and a second distal flange coupled to the second cylindrical portion at a second distal end spaced from the second proximal end.

The system further includes a spacer positioned between an adjacent proximal flange of one of the first cable reel and the second cable reel and an adjacent distal flange of the other of the first cable reel and the second cable reel, with the spacer being coupled to and extending axially outward from one of the adjacent proximal flange and the adjacent distal flange to support the first cable reel when the first cable reel is stacked over the second cable reel so that the first longitudinal axis is substantially coaxial with the second longitudinal axis.

BRIEF DESCRIPTION OF THE DRAWINGS

FIG. 1 is a schematic representation of a cable reel as typically found in the prior art.

FIGS. 2A and 2B are schematic representations of single and stacked cable reels as typically found in the prior art.

FIG. 3 is a perspective view of a cable reel with a built in pallet, in accordance with an exemplary embodiment of the present disclosure.

FIGS. 4A and 4B are close-up top and perspective views, respectively, of a flange of the cable reel of FIG. 3.

FIG. 5 is a side view of stacked cable reels, in accordance with the embodiment of FIG. 3.

3

FIG. 6 is an underside view of an upper cable reel supported on a fork lift, in accordance with another exemplary embodiment of the present disclosure.

FIGS. 7 and 7A are perspective views of the upper and lower flanges of the cable reel, in accordance with another exemplary embodiment of the present disclosure.

FIG. 8 is a close-up cross-sectional view of the upper and lower flanges of FIG. 7 in a mated configuration.

FIGS. 9 and 9A are perspective views of the upper and lower flanges of the cable reel, in accordance with another exemplary embodiment of the present disclosure.

FIG. 10 is a close-up cross-sectional view of the upper and lower flanges of FIG. 9 in a mated configuration.

FIG. 11 is a perspective view of the upper and lower flanges of the cable reel, in accordance with yet another exemplary embodiment of the present disclosure.

FIG. 12 is a close-up cross-sectional view of the upper and lower flanges of FIG. 11 in a mated configuration.

DETAILED DESCRIPTION

Reference is now made in more detail to the above drawing figures, wherein like reference numerals indicate like parts throughout the several views.

Illustrated in FIGS. 3-12 are several representative embodiments of a cable reel and a system for stacking a plurality of cable reels, which embodiments also include various methods for stacking cable reels on top of each other, end-to-end, for transportation and storage. As described hereinbelow, the cable reel stacking system provides several significant advantages and benefits over other systems and methods for stacking and storing cable reels. However, the recited advantages are not meant to be limiting in any way, as one skilled in the art will appreciate that other advantages may also be realized upon practicing the present invention.

FIG. 3 is a perspective view of a cable reel 20 having a built in pallet, in accordance with a representative embodiment of the present disclosure. The cable reel 20 includes a barrel portion 30 (not visible as it is covered by the cable 14) having a longitudinal axis 32 and a first flange 40 mounted at a first end 34. The first flange 40 includes an outer face 41 having a spacer 60 extending outwardly therefrom in an axial direction. The cable reel 20 also includes a second flange 42 mounted at a second end 36. In some aspects, the outer face 43 of the second flange 42 can include alignment features (not shown) which are complimentary with the spacer 60 that extends axially outward from the outer face 41 of the first flange 40, as will be discussed in more detail below. In other aspects, the outer face 43 of the second flange 42 may not include alignment features.

For visibility purposes, in FIG. 3 the cable reel 20 is oriented with the first flange 40 being the upper or top flange and the second flange 42 being the lower or bottom flange. However, as will be appreciated by one of skill in the art, the orientation of the cable reel 20 is completely reversible, with the first flange 40 being positioned at the bottom and the second flange 42 at the top.

Referring now to FIGS. 4A and 4B, the first flange 40 can comprise a number of structural features formed into or through the outer face 41 which may also be included, but not necessarily required, in other embodiments of the disclosure. These structural features include a central hub portion 44 that more or less aligns with the barrel, a spindle hole 46, and one or more drive holes 47. The hub portion may also include a plurality of bolt recesses 48 with bolts 49 installed therein. The bolts 49 can attach the first flange 40

4

either directly to the barrel portion or to the second flange 42 with the barrel portion being clasped there between, depending upon the design of the cable reel 20. Other systems and methods for attaching the flange 40 to the barrel or to the opposing flange 42 are also possible and may be considered to fall within the scope of the present disclosure.

The first flange can further include an outer portion 54 that is radially positioned between the hub portion 44 and the outer rim 58 of the flange 40. The outer portion can also include a plurality of structural ribs 56 which stiffen and strengthen the periphery of the flange 40, as well as an optional start hole 57 for feeding the end of the cable therethrough when winding the cable into the cable reel 20. As shown in FIG. 4B, the end of the cable 14 which extends through the start hole 57, also known as a pigtail 16, can be secured to the outer face 41 of the flange 40 with tie wraps.

The second flange 42 can include structural features formed into its outer face 43 which are similar to those included in the first flange, so that the two flanges have a measure of interchangeability when mounted within a mandrel (not shown) during the winding or unwinding of the cable. For instance, both the first and second flanges 40, 42 can include spindle holes 46 and drive holes 47 that are sized and configured for the same type of mandrel apparatus, which allows the cable to be mounted and wound or unwound from either direction.

As shown in FIGS. 3, 4A and 4B, both the first flange 40 and the second flange 42 can be formed from a composite material, such as a compression-molded wood plastic composite, a thermoplastic, and the like, which can allow for the structural features described above to be included in the molds which are used to form the flange. In other embodiments the flanges can be made from wood, such as nailed wood or plywood, which generally result in a smooth outer face 41, 43 of the flanges 40, 42 and in which the spindle hole, the drive hole(s), and the bolt holes may be drilled separately.

In the case of composite flanges, both the spacer 60 included in the first flange 40 and the alignment features (not shown) included in the second flange 42 can be formed integral with their respective flanges or added subsequent to the making of the flange. In the case of the wooden flanges, the spacer and alignment features can be separate structures which are added later.

With the embodiment of the disclosure illustrated in FIGS. 4A and 4B, the spacer 60 can comprise a round spacer ring 62 having a thickness 64 that is configured to support the weight of one or more loaded cable reels stacked one on top the other. As shown in FIG. 5, moreover, the spacer ring 62 can have a height 65 that is sufficient to create a gap between the outer faces 41, 43 of the opposing flanges 40, 42 so that the forks 12 of a fork lift can enter between the flanges without having to further pry apart the two faces.

Finally, as shown in FIG. 6, the spacer 60 (in this case, segmented spacer ring 72) can be centered on the first flange 40, and can have a diameter 73 which locates the spacer ring 72 within the outer portion 54 of the flange first 40, so that the forks 12 will be positioned interior to the outer rim 58 of the flange 40 and underneath the outer boundary of the cable 14 that has been wrapped around the drum of the cable reel 20 (see also FIG. 1).

FIGS. 7, 7A and 8 together illustrate one embodiment of a system 90 for stacking a plurality of cable reels 20A, 20B that includes the spacer 60 or spacer ring 62 of FIG. 3 molded or attached to the outer face 41 of the first flange 40, and one or more complimentary alignment features 80 molded or attached to the outer face 43 of the second flange

5

42. In this case, the alignment features **80** can include a plurality of alignment tabs **82** located both at an alignment tab radius **83** and at regular angular intervals around the outer face **43** of the second flange **42**. As shown in FIG. 7A, in one aspect the alignment tabs **82** can project outwardly in the axial direction from the ribs **56** formed into the outer portion **54** of the second flange **42**.

Referring now to FIG. 8, in one aspect the radius **83** of the alignment tabs **82** can be slightly less than $\frac{1}{2}$ the diameter **63** of the spacer ring **62**, so that when the two flanges are brought together in alignment, the inside surface of the spacer ring **62** abuts against the outside edges of the alignment tabs **82**. Thus, when located at regular angular intervals around the outer face **43** the second flange **42**, the alignment tabs **82** can restrict the lateral or sliding movement of the spacer ring **62**, and therefore the cable reel **20A**, in any direction.

In one aspect, either or both of the inside surface of the spacer ring **62** and outside edges of the alignment tabs **82** may taper away from their complimentary or mating structure, as viewed from the base portion proximate the flange towards the tip of the structure. This taper can provide a wider tolerance when first aligning the two complimentary structures, which then tightens as the two flanges are brought into greater contact with each other.

In yet another aspect of the present disclosure, the radius **83** of the alignment tabs **82** can be substantially less than $\frac{1}{2}$ the diameter **63** of the spacer ring **62**, so that when the upper flange **40** is positioned on top the lower flange **42**, the inside surface of the spacer ring **62** does not abut against the outside edges of all the alignment tabs **82**, but instead contacts fewer than all the alignment tabs, or even possibly no alignment tabs if well centered. Thus, the longitudinal axis of the upper reel **20A** may not be forced into alignment with the longitudinal axis of the lower cable reel **20B**, but instead can be offset or skewed to one side. Nevertheless, the interaction between the alignment tabs **82** on the second flange **42** and the spacer ring **62** extending from the first flange **40** can be sufficient to keep the upper cable reel **20A** from sliding more than a small distance across the outer face **43** on the second flange **42** of the lower cable reel **20B**. Such a configuration can make it easier for driver of the forklift to stack the cable reels by allowing for greater tolerances when positioning the upper cable reel **20A** on top of the lower cable reel **20B**.

It is also to be appreciated that in some embodiments the alignment tabs **82** can be positioned outside the spacer ring **62** and at a radius **83** that is greater (whether slightly or substantially) than $\frac{1}{2}$ the diameter **63** of the spacer ring **62**, so that when the two flanges are brought together in alignment, the outside surface of the spacer ring **62** abuts against the inside edges of one or more alignment tabs **82**, and thereby restricts the lateral or sliding movement of the spacer ring **62**, and therefore the cable reel **20A**, in any direction.

FIGS. 9, 9A and 10 together illustrate another embodiment of a system **92** for stacking a plurality of cable reels **20C**, **20D** that includes the spacer **60** or spacer ring **66** (which spacer ring **66** is similar to the spacer ring **62** shown in FIG. 3, only taller) molded or attached to the outer face **41** of the first flange **40**. In this case, however, the complimentary alignment feature **80** can include a plurality of alignment slots **84** (or a continuous recess) which have been molded into the outer face **43** of the second flange **41** at an alignment slot radius **85**. As shown in FIG. 9A, in one aspect the alignment slots **84** can extend inwardly into the ribs **56** formed into the outer portion **54** of the second flange **41**.

6

Referring now to FIG. 10, the radius **85** of the alignment slots **84** can equal to $\frac{1}{2}$ the diameter **63** of the spacer ring **66**, and the spacer ring **66** can have a height **65** that is greater than the embodiment of the spacer ring shown in FIG. 3. Thus, when the two flanges are brought together in alignment, the tip portion **67** of the spacer ring **66** can be captured within the sidewalls of the alignment slots **84** while maintaining the same separation distance between the outer faces **41**, **42** of the flanges **40**, **42** to allow for insertion of the forks there in between. Like the alignment tabs described above, the alignment slots **84** can also function to restrict the lateral or sliding movement of the spacer ring **66**, and therefore the cable reel **20C**, in any direction. In providing for an embodiment that allows for greater tolerances in positioning the upper cable reel **20C** on top of the lower cable reel **20D**, however, in this case the width of the alignment slots **84** can be substantially greater than the thickness of the spacer ring **66** to allow a forklift truck driver greater flexibility in stacking the cable reels.

FIGS. 11 and 12 together illustrate another embodiment of a system **94** for stacking a plurality of cable reels **20E**, **20F** that includes the spacer **60**, in this case a spacer cap **68**, that can be removably attached to the outer face **41** of the first flange **40**. The spacer cap **68** can have an outer diameter **63** and a substantially-planar top surface **69** which can seat securely against an outer face **43** of a second flange **42** which is substantially flat, such as when the second flange is made of wood. In this case, the complimentary alignment feature **80** can be a plurality of alignment tabs **86** located both at an alignment tab radius **87** and at regular angular intervals around the outer face **43** of the second flange **42**, and which can project axially outward from the substantially flat face **43** of the second flange **42**.

Referring now to FIG. 12, the radius **87** of the alignment tabs **86** can be slightly greater than $\frac{1}{2}$ the diameter **63** of the spacer cap **68**, so that when the two flanges are brought together in alignment, the outside surface of the spacer cap **68** abuts against the inside edges of the alignment tabs **86**. Here again, when located at regular angular intervals around outer face **43** the second flange **42**, the alignment tabs **86** can restrict the lateral or sliding movement of the spacer cap **68**, and therefore the cable reel **20E**, in any direction.

And in yet another embodiment of the present disclosure, the radius **87** of the alignment tabs **86** can be substantially greater than $\frac{1}{2}$ the diameter **63** of the spacer cap **68**, in order to provide for greater tolerances in positioning the upper cable reel **20E** on top of the lower cable reel **20F** to allow a forklift truck driver greater flexibility in stacking the cable reels. Nevertheless, the interaction between the alignment tabs **86** on the second flange **42** and the spacer ring **62** extending from the first flange **40** can be sufficient to keep the upper cable reel **20E** from sliding more than a small distance across the outer face **43** on the second flange **42** of the lower cable reel **20F**.

Another advantage with the alignment cap **68** is that it can cover and protect the pigtail of the cable during storage and transportation of the cable reel **20E**. Referring back to FIG. 4B, this is similar to the protection provided to the pigtail **16** of the cable **14** by the open spacer ring **62** shown in the drawing, but with the additional coverage over the top of the volume surrounded and defined by the spacer ring **62**.

It is to be appreciated that the spacer **60** of the present disclosure is not limited to the circular embodiments described herein, and may comprise a variety of polygonal shapes included octagons, hexagons, a square, and the like. Such shapes may correspond with complementary recesses formed into the outer surface **43** of the second flange **42**. It

is also to be appreciated that the spacer 60 can constructed and mounted to the outer surface 41 of the first flange 40 using a variety of methods, including but not limited to the segmented spacer ring 72 shown in FIG. 6 which can be formed from a plurality of segments 74, each of which is individually attached to the first flange 40 with a fastener, such as bolt 76.

The invention has been described herein within the context of preferred embodiments and methodologies considered by the inventor to represent the best mode of carrying out the invention. It will be apparent to those of skill in the art, however, that a large number of additions, deletions, and modifications, both subtle and gross, may well be made to the illustrated embodiments without departing from the spirit and scope of the invention, which is delineated only by the claims hereof.

The invention claimed is:

1. A winding apparatus comprising:
 - a cylindrical body having a longitudinal central axis, a first end, and a second end spaced from the first end;
 - a flange coupled to the first end of the cylindrical body and having an outer face and an outer rim;
 - a spacer extending axially outward from the outer face, the spacer being configured to support the winding apparatus with the flange spaced above a support surface when the longitudinal central axis of the winding apparatus is in a substantially vertical orientation, the spacer comprising an annular ring centered about the longitudinal central axis; and
 - a plurality of structural ribs affixed to the flange; wherein the plurality of structural ribs define a planar surface located radially inward of the outer rim and radially outward of the spacer for receiving in flat abutting relationship an upper surface of a pair of forklift forks.
2. The winding apparatus of claim 1 wherein the spacer is molded to the flange.
3. The winding apparatus of claim 1 wherein the spacer is coupled to the flange.
4. The winding apparatus of claim 1 wherein the spacer is symmetric about the longitudinal axis and wherein the spacer has a height and a constant diameter along its height.

5. The winding apparatus of claim 1 further comprising a second flange coupled to the second end of the cylindrical body.

6. A system for stacking a plurality of cable reels, the system comprising:

- a first cable reel, the first cable reel including a first cylindrical drum having a first longitudinal axis, a lower flange coupled to the first cylindrical drum at a lower end, and an upper flange coupled to the first cylindrical drum at an upper end spaced from the lower end;
- a second cable reel, the second cable reel including a second cylindrical drum having a second longitudinal axis, a lower flange coupled to the second cylindrical drum at a lower end, and an upper flange coupled to the second cylindrical drum at an upper end spaced from the lower end; and
- a spacer positioned between opposing faces of the lower flange of the first cable reel and the upper flange of the second cable reel when the first cable reel is stacked over the second cable reel so that the first longitudinal axis is substantially coaxial with the second longitudinal axis;

wherein the spacer extends axially downward from the lower flange of the first cable reel to support the first cable reel upon and spaced above the upper flange of the second cable reel; and

wherein the spacer is spaced inwardly from an outer rim of the lower flange of the first cable reel to form a circumferential gap between the opposing faces that is accessible with the forks of a fork lift vehicle from all directions, and wherein the spacer comprises an annular ring centered about the first longitudinal axis.

7. The system of claim 6 wherein the lower flange of the first cable reel defines a planar surface located radially inward of the outer rim for receiving an upper surface of a pair of forklift forks in flat abutting relationship.

8. The system of claim 7 wherein the first cable reel further comprises a plurality of radially extending structural ribs affixed to the lower flange.

* * * * *