



US009743223B2

(12) **United States Patent**  
**Liu et al.**

(10) **Patent No.:** **US 9,743,223 B2**  
(45) **Date of Patent:** **Aug. 22, 2017**

(54) **TECHNIQUES FOR COMMUNICATING USING CONDUCTED RF LINKS**

(58) **Field of Classification Search**  
CPC ..... H04W 4/008  
See application file for complete search history.

(71) Applicant: **Apple Inc.**, Cupertino, CA (US)

(56) **References Cited**

(72) Inventors: **Hsin-Yuo Liu**, Fremont, CA (US);  
**Indranil S. Sen**, Fremont, CA (US);  
**Mohit Narang**, San Jose, CA (US);  
**Peter M. Agboh**, San Francisco, CA (US);  
**Ruben Caballero**, San Jose, CA (US)

**U.S. PATENT DOCUMENTS**

6,392,504 B1	5/2002	Stein	
7,532,861 B2	5/2009	Ranta et al.	
8,682,269 B1 *	3/2014	Rajendran	H04B 1/18 455/136
8,868,145 B2	10/2014	Rofougaran et al.	
9,136,655 B2	9/2015	Moon et al.	
2006/0139833 A1 *	6/2006	Ranta	H01Q 1/246 361/113
2009/0247082 A1 *	10/2009	Sathath	G06F 1/1616 455/41.2
2013/0332632 A1 *	12/2013	Rathi	H04M 1/72527 710/38
2016/0276735 A1 *	9/2016	Sun	H01Q 1/36

(73) Assignee: **APPLE INC.**, Cupertino, CA (US)

(\*) Notice: Subject to any disclaimer, the term of this patent is extended or adjusted under 35 U.S.C. 154(b) by 0 days.

**FOREIGN PATENT DOCUMENTS**

EP 1 988 650 B1 9/2012

\* cited by examiner

(21) Appl. No.: **14/871,903**

(22) Filed: **Sep. 30, 2015**

*Primary Examiner* — Christopher M Brandt  
(74) *Attorney, Agent, or Firm* — Fletcher Yoder PC

(65) **Prior Publication Data**

US 2016/0353232 A1 Dec. 1, 2016

**Related U.S. Application Data**

(60) Provisional application No. 62/168,272, filed on May 29, 2015.

(57) **ABSTRACT**

Electronic devices may communicate with each other using a “conducted RF link.” Such a conducted RF link is essentially a link that utilizes a conductor or cable that facilitates communication between electronic devices. Instead of the conductor carrying a traditional signal, it carries a modulated RF signal, such as those produced by a typical wireless RF radio like presently available WiFi/Bluetooth® cores.

(51) **Int. Cl.**

**H04W 4/00** (2009.01)  
**H04W 52/02** (2009.01)  
**H04W 88/06** (2009.01)

**20 Claims, 11 Drawing Sheets**

(52) **U.S. Cl.**

CPC ..... **H04W 4/008** (2013.01); **H04W 52/0274** (2013.01); **H04W 88/06** (2013.01); **Y02B 60/50** (2013.01)

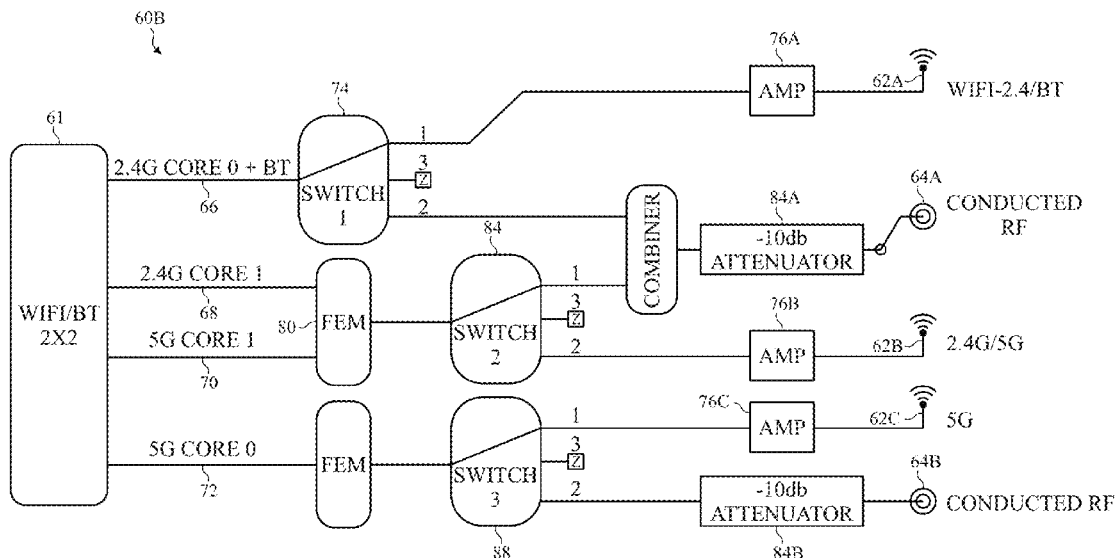

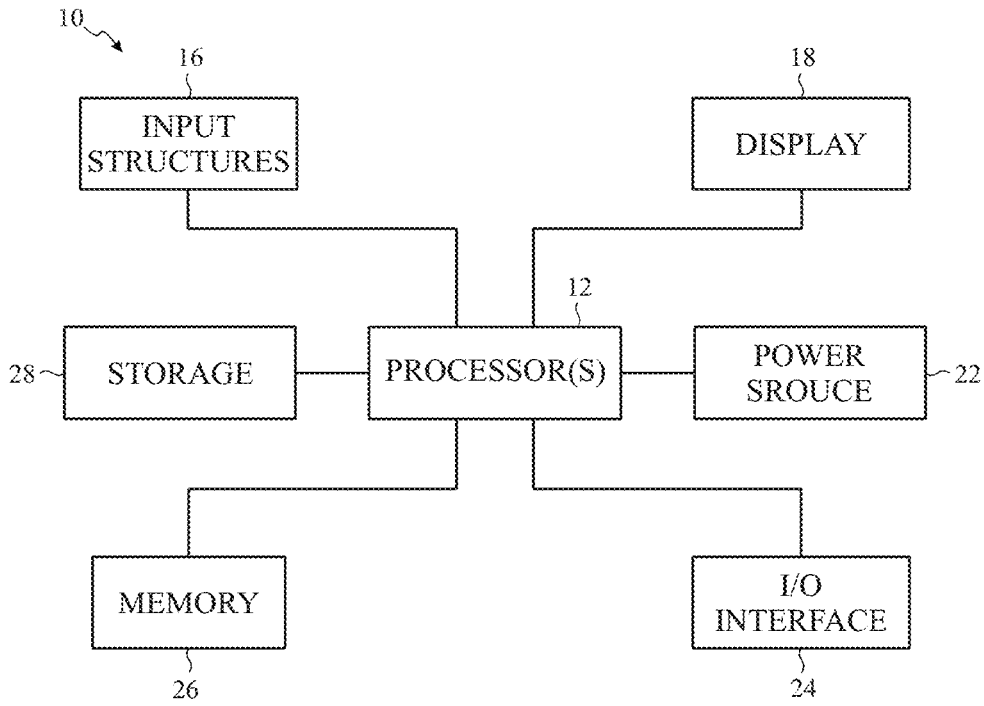

FIG. 1

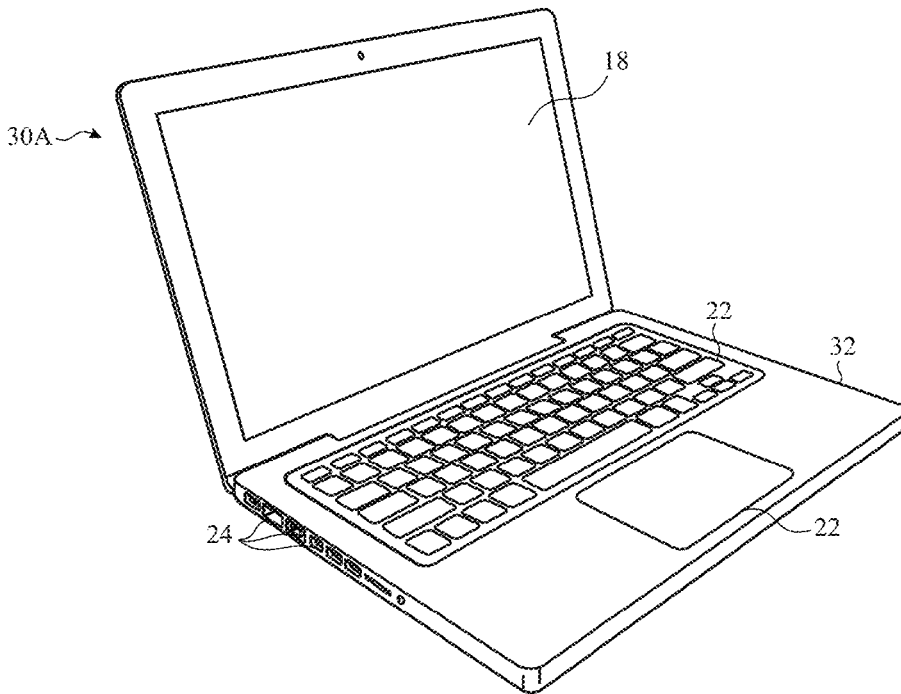

FIG. 2

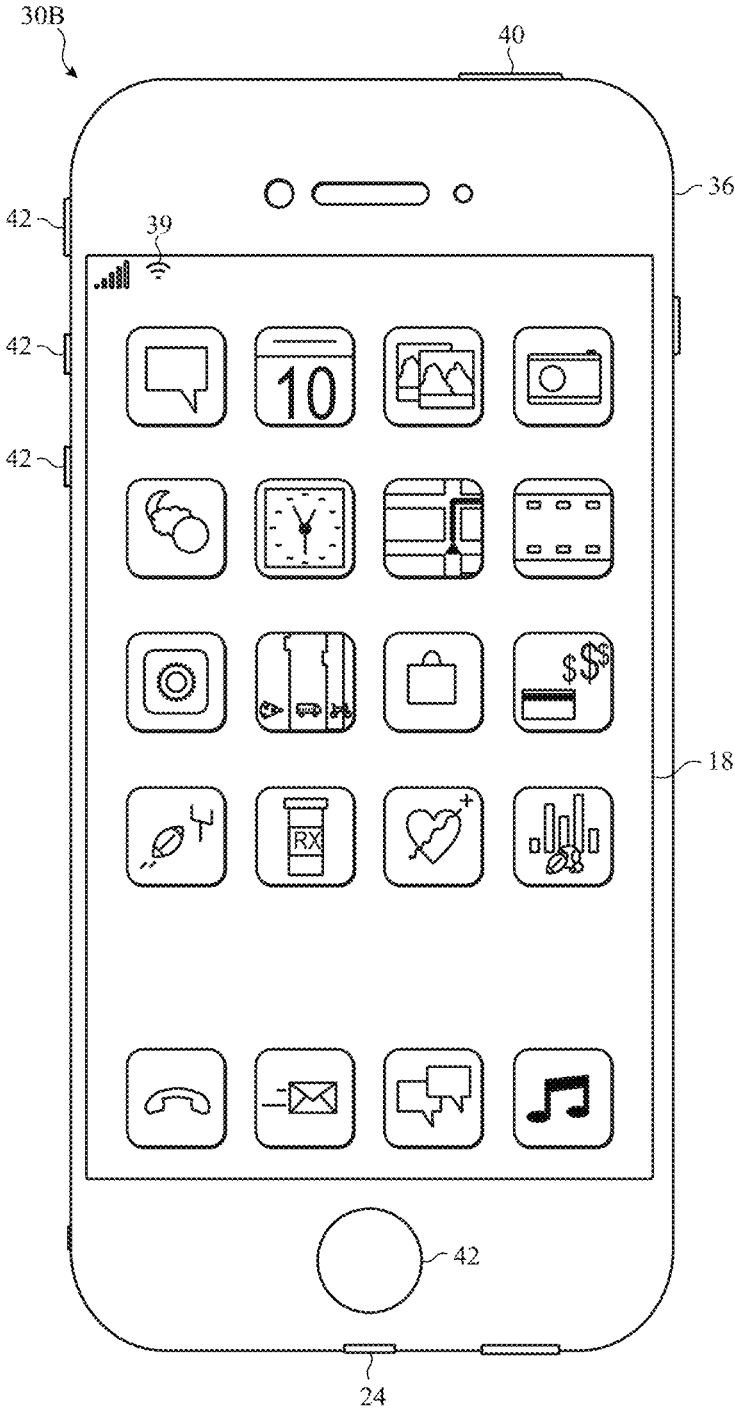

FIG. 3

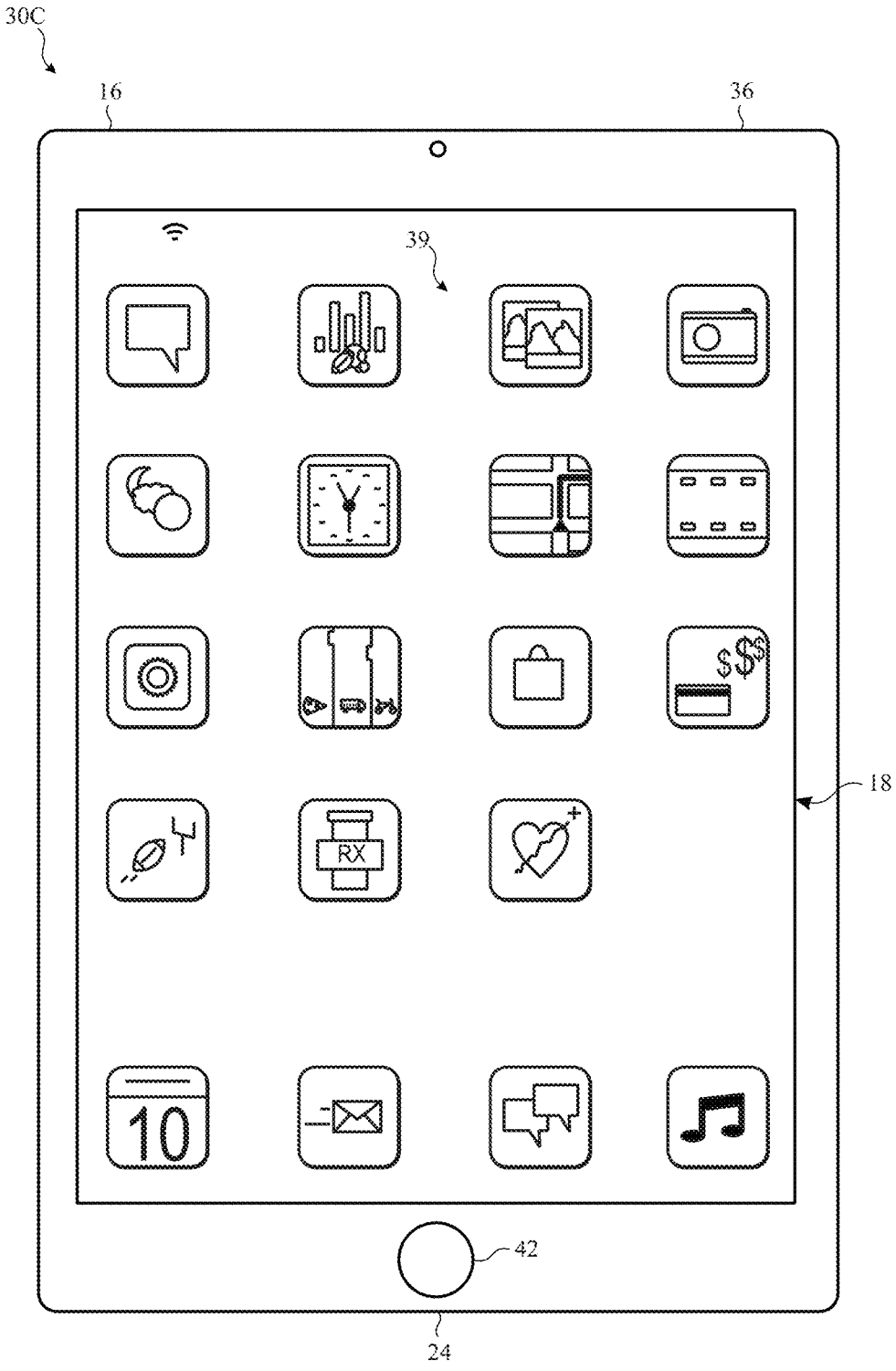

FIG. 4

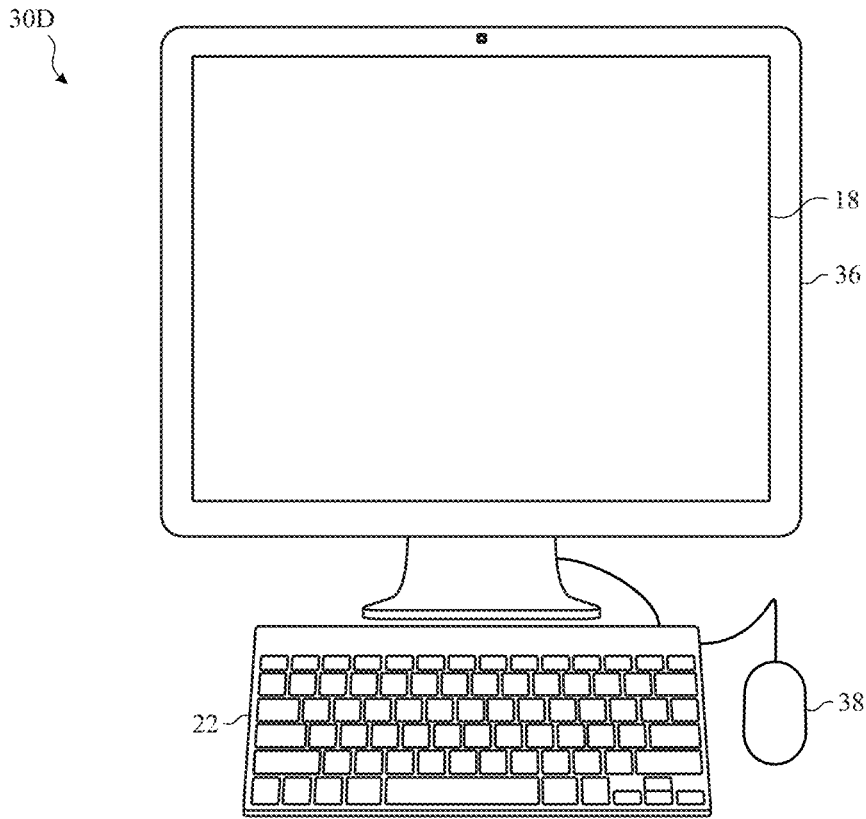

FIG. 5

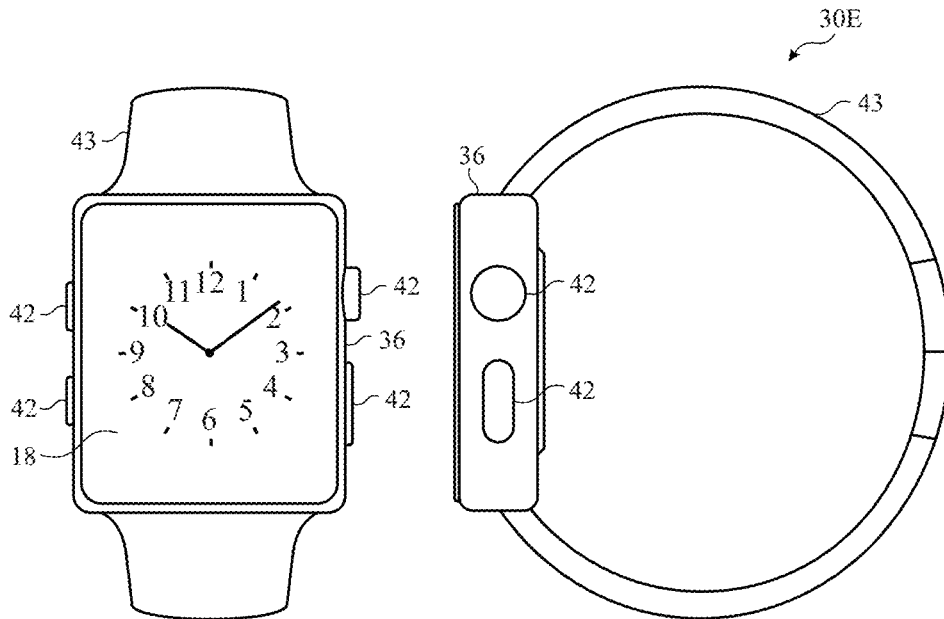
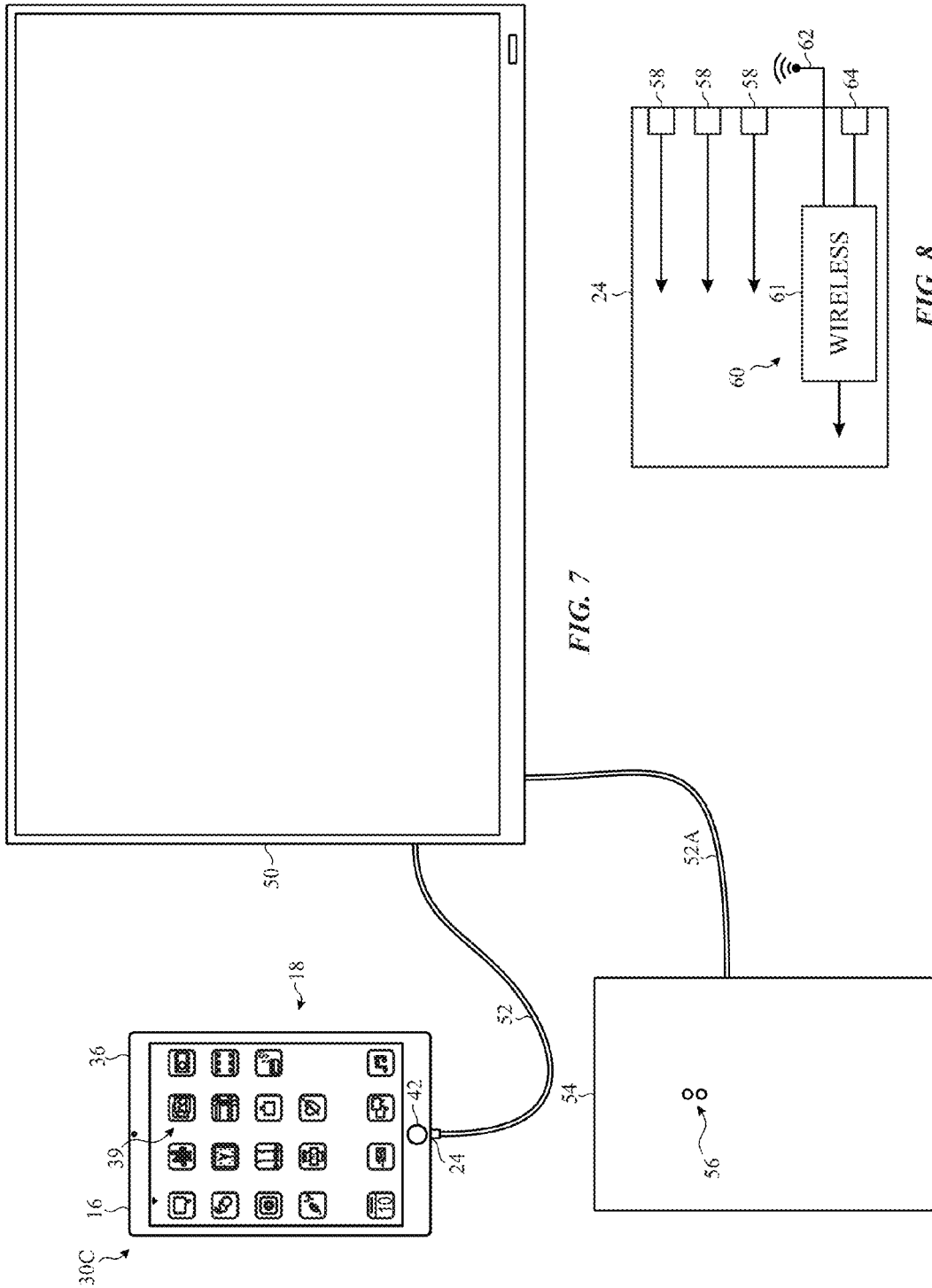

FIG. 6



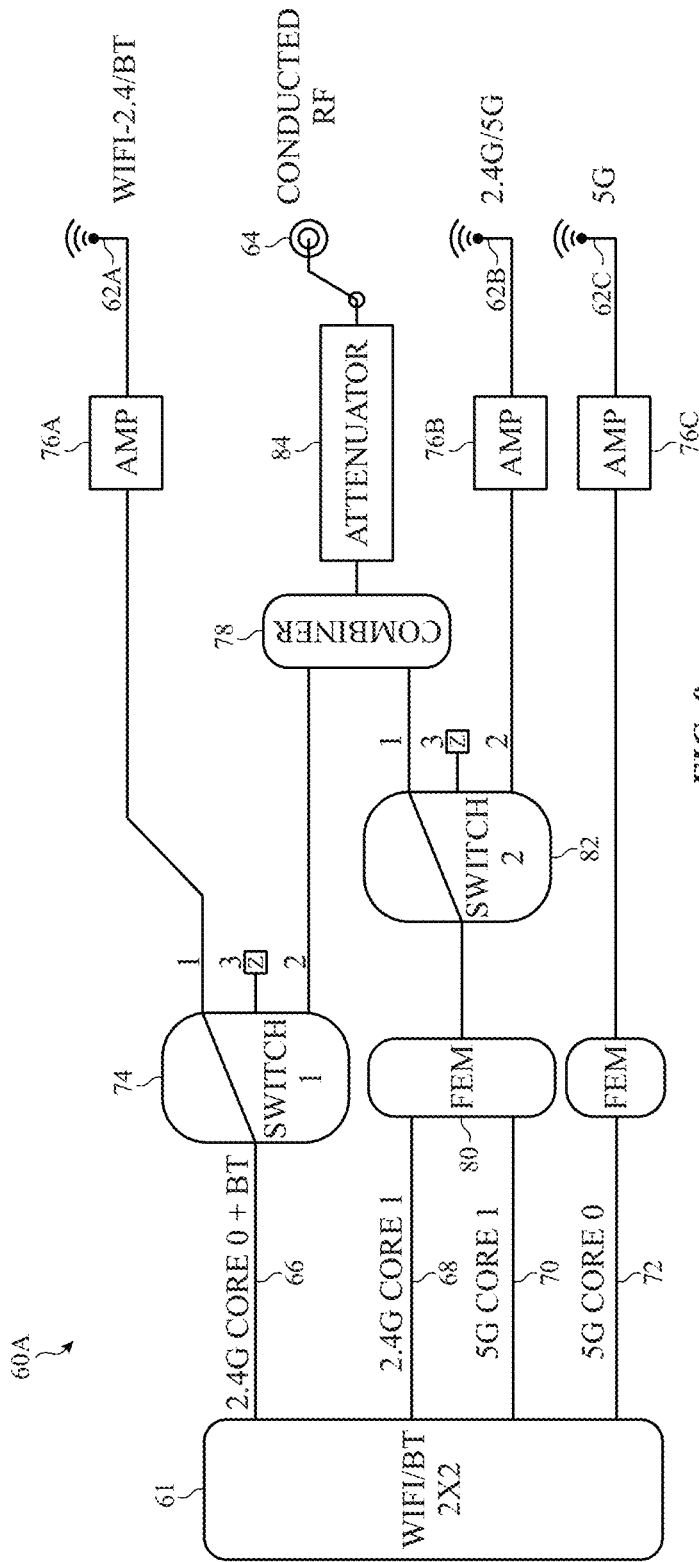

FIG. 9

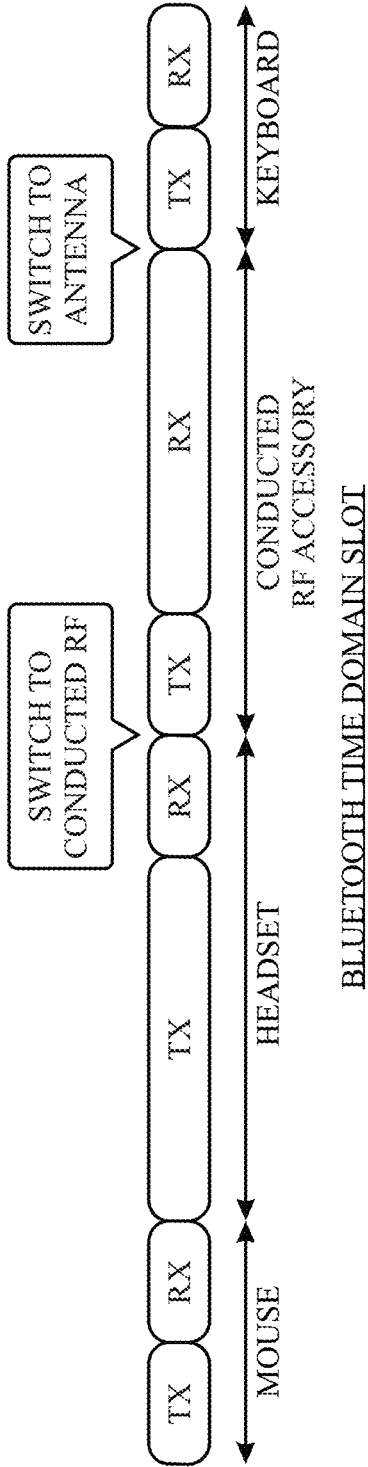

FIG. 10

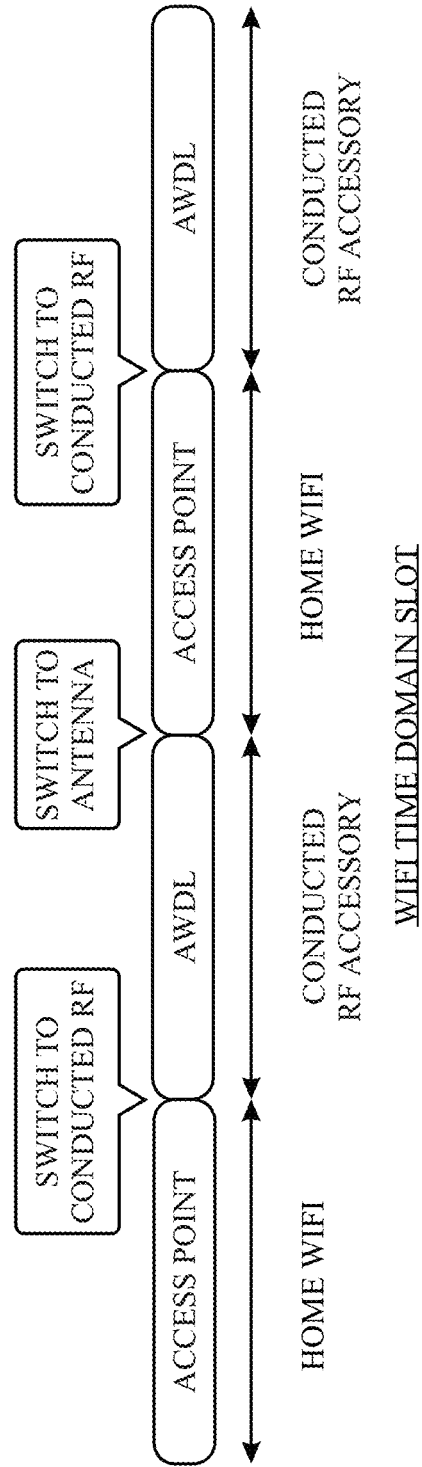

FIG. 11



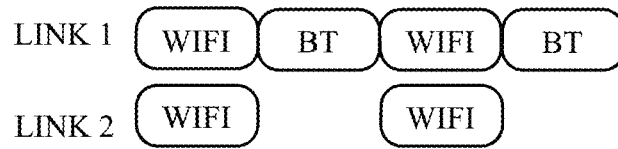

FIG. 12

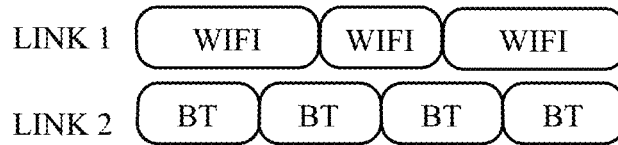

FIG. 13

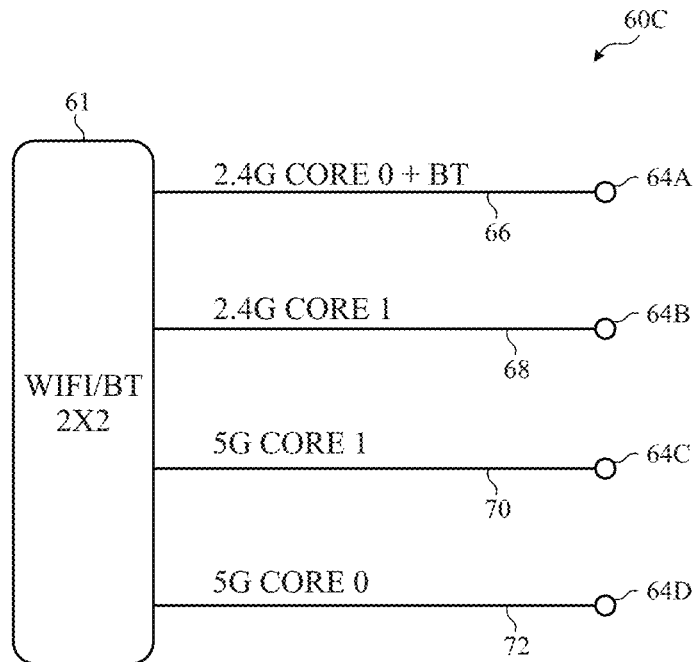

FIG. 15

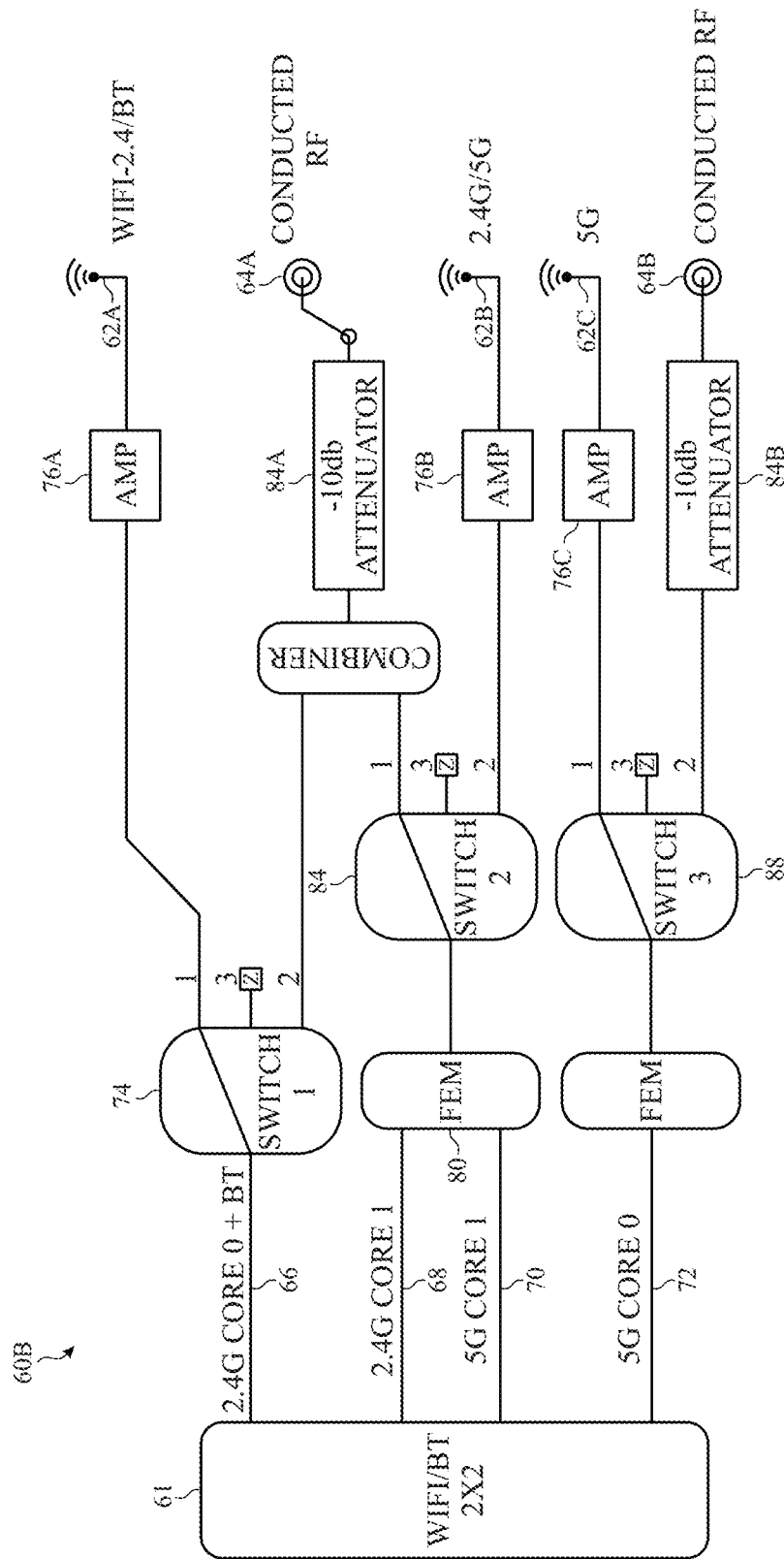

FIG. 14

I		II		III		IV		V		VI		VII		VIII	
Active Radio	Accessory	CoEx Scenario		BT Radio Throughput (Mbps)	WiFi Ratio Throughput (Mbps)	Conducted RF Throughput (Mbps)	SW1	SW2							
A	using BT	/	/	/	/	2.1	2	3							
	using WiFi 2.5GHz	/	/	/	/	60/320	3	1							
B	using BT	WiFi SISO Simultaneous Operation 1+1		/	60	2.1	2	2							
		MIMO TDD		/	Up to 120	Up to 2.1	1/2	2/3							
		MIMO TDD		/	Up to 120	Up to 60	1/2	2/3							
C	using WiFi 5GHz	MIMO TDD		/	Up to 120	Up to 320	1/3	2/1							
		MIMO Simultaneous Operation		/	550	2.1	2	2							
		MIMO TDD		/	Up to 550	Up to 60	3/2	2/3							
D	Using BT	BT TDD		Up to 2.1	/	Up to 2.1	1/2	3							
	using WiFi 2.5GHz	BT Simultaneous Operation 1+1		2.1	/	60/320	1	1							

FIG. 16

Configuration Scenarios		III	IV	V	VI	VII	VIII
I	II	CoEx scenario	BT Radio Throughput (Mbps)	WiFi Radio Throughput (Mbps)	Conducted RF Throughput (Mbps)	Switch 1	Switch 2
Active Radio	Arbitrary						
E BT + WiFi 2.4GHz	using BT	MIMO TDD	Up to 2.1	Up to 120	Up to 2.1	1/1/2	3/2/3
	using WiFi 2GHz	MIMO TDD	2.1*	Up to 120	Up to 60	1/1/2	3/2/3
	using WiFi 5GHz	MIMO TDD	2.1*	Up to 120	Up to 320	1/1/3	3/2/1
F BT + WiFi 5GHz	using BT	MIMO Simultaneous Operation	Up to 2.1	550	Up to 2.1	1/1/2	2/2/2
	using WiFi 2GHz	BT Simultaneous Operation + MIMO/TDD	2.1	Up to 550	Up to 60	1/1/1	2/2/1
	using WiFi 5GHz	BT Simultaneous Operation + MIMO/TDD	2.1	Up to 550	Up to 320	1/1/1	2/2/1

\*\*Bluetooth high priority

FIG. 17

## TECHNIQUES FOR COMMUNICATING USING CONDUCTED RF LINKS

### CROSS REFERENCE TO RELATED APPLICATIONS

This application is a Non-Provisional application claiming priority to U.S. Provisional Patent Application No. 62/168,272, entitled “Techniques for Communicating Using Conducted RF Links”, filed May 29, 2015, which is herein incorporated by reference.

### BACKGROUND

The present disclosure relates generally to techniques for facilitating communication between two electronic devices and, more particularly to, techniques that utilize a conducted radio frequency (RF) link to facilitate communication between electronic devices.

This section is intended to introduce the reader to various aspects of art that may be related to various aspects of the present disclosure, which are described and/or claimed below. This discussion is believed to be helpful in providing the reader with background information to facilitate a better understanding of the various aspects of the present disclosure. Accordingly, it should be understood that these statements are to be read in this light, and not as admissions of prior art.

In the marketplace today, there are a wide variety of electronic devices available for a wide variety of purposes. Such devices include cellular telephones, tablet computers, laptop computers, personal computers, televisions, headphones, Bluetooth® enabled watches, printers, and cameras, just to name a few. It is often desirable for one electronic device to communicate with one or more other electronic devices. Traditionally, such connections have been “hard-wired”, such that the devices had to be connected directly to one another by some sort of cabling or by cabling via a network interface. Such cabling is typically terminated by standardized connectors (e.g., USB, RS232, etc.) or by proprietary connectors, e.g. Apple’s Lightning® connector, etc. Hence, not only does the cabling solution require a plethora of unsightly wires, it often requires specific types of cables and/or adaptors because of the wide variety of connectors and signaling schemes.

In addition to some of these disadvantages, cables are subject to wear and tear. Their conductors and insulation can be damaged, and their connectors can break, corrode, or become too dirty to conduct signals properly. These problems tend to reduce the ability of the cables to send and receive signals accurately, thus limiting their speed and efficiency.

To address many of these concerns, various wireless technologies have become popular for facilitating communication between electronic devices. For example radio frequency (RF) technologies, such as WiFi (IEEE 802.11) and Bluetooth® (IEEE 802.15), are now commonly used by many electronic devices to facilitate communication without the need for cabling. Although such wireless interfaces address some of the problems with cabling, they are subject to their own disadvantages. For example, because wireless signals are transmitted through the air, they can be received by devices other than those intended by the user, thus creating potential security problems. Furthermore, because wireless signals typically need to be amplified more than signals that travel on an actual conductor, electronic devices typically utilize more power when communicating wire-

lessly, thus reducing battery life. Further, such devices are also subject to various regulatory requirements due to the fact that they radiate energy.

### BRIEF DESCRIPTION OF THE DRAWINGS

Various aspects of this disclosure may be better understood upon reading the following detailed description and upon reference to the drawings in which:

FIG. 1 is a schematic block diagram of an electronic device including display control circuitry, in accordance with an embodiment;

FIG. 2 is a perspective view of a notebook computer representing an embodiment of the electronic device of FIG. 1, in accordance with an embodiment;

FIG. 3 is a front view of a hand-held device representing another embodiment of the electronic device of FIG. 1, in accordance with an embodiment;

FIG. 4 is a front view of another hand-held device representing another embodiment of the electronic device of FIG. 1, in accordance with an embodiment;

FIG. 5 is a front view of a desktop computer representing another embodiment of the electronic device of FIG. 1, in accordance with an embodiment;

FIG. 6 is a front view of a wearable electronic device representing another embodiment of the electronic device of FIG. 1, in accordance with an embodiment.

FIG. 7 is a diagram illustrating a first electronic device, such as a tablet computer, communicating with a second electronic device, such as a television, via a conducted RF link;

FIG. 8 is a schematic diagram of one example of an I/O interface that includes one or more traditional ports along with one or more wireless links and conducted RF links;

FIG. 9 is a schematic diagram of an example an RF circuit that facilitates both wireless communication and conducted RF communication;

FIG. 10 is a diagram illustrating an example of a Bluetooth® time domain slot for wireless and conducted RF communication;

FIG. 11 is diagram illustrating an example of a WiFi time domain slot for wireless and conducted RF communication;

FIG. 12 is a diagram illustrating an example of a multiple in multiple out (MIMO) time division duplex scheme for the circuit illustrated in FIG. 11;

FIG. 13 is a diagram illustrating an example of a single in single out (SISO) communication scheme for the circuitry illustrated in FIG. 11;

FIG. 14 is another example of an RF circuit for facilitating both wireless communication and conducted RF communication;

FIG. 15 is a schematic diagram of an RF circuit for facilitating multiple conducted RF links; and

FIGS. 16 and 17 are charts depicting various configuration scenarios for the RF circuit of FIG. 9.

### DETAILED DESCRIPTION OF SPECIFIC EMBODIMENTS

One or more specific embodiments will be described below. In an effort to provide a concise description of these embodiments, not all features of an actual implementation are described in the specification. It should be appreciated that in the development of any such actual implementation, as in any engineering or design project, numerous implementation-specific decisions must be made to achieve the developers’ specific goals, such as compliance with system-

related and business-related constraints, which may vary from one implementation to another. Moreover, it should be appreciated that such a development effort might be complex and time consuming, but would nevertheless be a routine undertaking of design, fabrication, and manufacture for those of ordinary skill having the benefit of this disclosure.

When introducing elements of various embodiments of the present disclosure, the articles “a,” “an,” and “the” are intended to mean that there are one or more of the elements. The terms “comprising,” “including,” and “having” are intended to be inclusive and mean that there may be additional elements other than the listed elements. Additionally, it should be understood that references to “one embodiment” or “an embodiment” of the present disclosure are not intended to be interpreted as excluding the existence of additional embodiments that also incorporate the recited features.

To address some of the concerns mentioned above, it is proposed to allow electronic devices to communicate with each other using a “conducted RF link.” Such a conducted RF link is essentially a link that utilizes a conductor or cable that facilitates communication between electronic devices, but instead of the cable carrying a traditional signal it carries a modulated RF signal, such as those produced by a typical wireless RF radio like presently available WiFi/Bluetooth® cores. Because the signal is transmitted via a conductor as opposed to an air interface, it does not require the amount of amplification of a wireless signal, thus saving power compared to wireless communication. Furthermore, since the signal is not transmitted over the air, wireless security problems are not an issue. In addition, because a conducted RF link uses only a very simple connector scheme (only one conductor for the signal and another conductor for ground), many problems related to standardized and proprietary connectors are overcome. Indeed, because of the simplicity of the connection scheme, electronic devices can have surface contacts so that one merely places one electronic device on the surface of the other to facilitate the conducted RF connection.

With these features in mind, a general description of suitable electronic devices that may use conducted RF links is provided. Turning first to FIG. 1, an electronic device 10 according to an embodiment of the present disclosure may include, among other things, one or more processor(s) 12, memory 14, nonvolatile storage 16, a display 18 input structures 22, an input/output (I/O) interface 24 and a power source 26. The various functional blocks shown in FIG. 1 may include hardware elements (e.g., including circuitry), software elements (e.g., including computer code stored on a computer-readable medium) or a combination of both hardware and software elements. It should be noted that FIG. 1 is merely one example of a particular implementation and is intended to illustrate the types of components that may be present in electronic device 10.

By way of example, the electronic device 10 may represent a block diagram of the notebook computer depicted in FIG. 2, the handheld device depicted in either of FIG. 3 or FIG. 4, the desktop computer depicted in FIG. 5, the wearable electronic device depicted in FIG. 6, or similar devices. It should be noted that the processor(s) 12 and/or other data processing circuitry may be generally referred to herein as “data processing circuitry.” Such data processing circuitry may be embodied wholly or in part as software, firmware, hardware, or any combination thereof. Furthermore, the data processing circuitry may be a single con-

tained processing module or may be incorporated wholly or partially within any of the other elements within the electronic device 10.

In the electronic device 10 of FIG. 1, the processor(s) 12 and/or other data processing circuitry may be operably coupled with the memory 14 and the nonvolatile memory 16 to perform various algorithms. Such programs or instructions executed by the processor(s) 12 may be stored in any suitable article of manufacture that includes one or more tangible, computer-readable media at least collectively storing the instructions or routines, such as the memory 14 and the nonvolatile storage 16. The memory 14 and the nonvolatile storage 16 may include any suitable articles of manufacture for storing data and executable instructions, such as random-access memory, read-only memory, rewritable flash memory, hard drives, and optical discs. Also, programs (e.g., e.g., an operating system) encoded on such a computer program product may also include instructions that may be executed by the processor(s) 12 to enable the electronic device 10 to provide various functionalities.

In certain embodiments, the display 18 may be a liquid crystal display (e.g., LCD), which may allow users to view images generated on the electronic device 10. In some embodiments, the display 18 may include a touch screen, which may allow users to interact with a user interface of the electronic device 10. Furthermore, it should be appreciated that, in some embodiments, the display 18 may include one or more light emitting diode (e.g., LED) displays, or some combination of LCD panels and LED panels.

The input structures 22 of the electronic device 10 may enable a user to interact with the electronic device 10 (e.g., e.g., pressing a button to increase or decrease a volume level). The I/O interface 24 may enable electronic device 10 to interface with various other electronic devices. The I/O interface 24 may include various types of ports that may be connected to cabling. These ports may include standardized and/or proprietary ports, such as USB, RS232, Apple’s Lightning® connector, as well as one or more ports for a conducted RF link. The I/O interface 24 may also include, for example, interfaces for a personal area network (e.g., PAN), such as a Bluetooth network, for a local area network (e.g., LAN) or wireless local area network (e.g., WLAN), such as an 802.11x Wi-Fi network, and/or for a wide area network (e.g., WAN), such as a 3<sup>rd</sup> generation (e.g., 3G) cellular network, 4<sup>th</sup> generation (e.g., 4G) cellular network, or long term evolution (e.g., LTE) cellular network. The I/O interface 24 may also include interfaces for, for example, broadband fixed wireless access networks (e.g., WiMAX), mobile broadband Wireless networks (e.g., mobile WiMAX), and so forth.

As further illustrated, the electronic device 10 may include a power source 26. The power source 26 may include any suitable source of power, such as a rechargeable lithium polymer (e.g., Li-poly) battery and/or an alternating current (e.g., AC) power converter. The power source 26 may be removable, such as replaceable battery cell.

In certain embodiments, the electronic device 10 may take the form of a computer, a portable electronic device, a wearable electronic device, or other type of electronic device. Such computers may include computers that are generally portable (e.g., such as laptop, notebook, and tablet computers) as well as computers that are generally used in one place (e.g., such as conventional desktop computers, workstations and/or servers). In certain embodiments, the electronic device 10 in the form of a computer may be a model of a MacBook®, MacBook® Pro, MacBook Air®, iMac®, Mac® mini, or Mac Pro® available from Apple Inc.

5

By way of example, the electronic device 10, taking the form of a notebook computer 30A, is illustrated in FIG. 2 in accordance with one embodiment of the present disclosure. The depicted computer 30A may include a housing or enclosure 32, a display 18, input structures 22, and ports of the I/O interface 24. In one embodiment, the input structures 22 (e.g., such as a keyboard and/or touchpad) may be used to interact with the computer 30A, such as to start, control, or operate a GUI or applications running on computer 30A. For example, a keyboard and/or touchpad may allow a user to navigate a user interface or application interface displayed on display 18.

FIG. 3 depicts a front view of a handheld device 30B, which represents one embodiment of the electronic device 10. The handheld device 34 may represent, for example, a portable phone, a media player, a personal data organizer, a handheld game platform, or any combination of such devices. By way of example, the handheld device 34 may be a model of an iPod® or iPhone® available from Apple Inc. of Cupertino, Calif.

The handheld device 30B may include an enclosure 36 to protect interior components from physical damage and to shield them from electromagnetic interference. The enclosure 36 may surround the display 18, which may display indicator icons 39. The indicator icons 39 may indicate, among other things, a cellular signal strength, Bluetooth connection, and/or battery life. The I/O interfaces 24 may open through the enclosure 36 and may include, for example, an I/O port for a hard wired connection for charging and/or content manipulation using a connector and protocol, such as the Lightning connector provided by Apple Inc., a universal serial bus (e.g., USB), one or more conducted RF connectors, or other connectors and protocols.

User input structures 40 and 42, in combination with the display 18, may allow a user to control the handheld device 30B. For example, the input structure 40 may activate or deactivate the handheld device 30B, one of the input structures 42 may navigate user interface to a home screen, a user-configurable application screen, and/or activate a voice-recognition feature of the handheld device 30B, while other of the input structures 42 may provide volume control, or may toggle between vibrate and ring modes. Additional input structures 42 may also include a microphone may obtain a user's voice for various voice-related features, and a speaker to allow for audio playback and/or certain phone capabilities. The input structures 42 may also include a headphone input to provide a connection to external speakers and/or headphones.

FIG. 4 depicts a front view of another handheld device 30C, which represents another embodiment of the electronic device 10. The handheld device 30C may represent, for example, a tablet computer, or one of various portable computing devices. By way of example, the handheld device 30C may be a tablet-sized embodiment of the electronic device 10, which may be, for example, a model of an iPad® available from Apple Inc. of Cupertino, Calif.

Turning to FIG. 5, a computer 30D may represent another embodiment of the electronic device 10 of FIG. 1. The computer 30D may be any computer, such as a desktop computer, a server, or a notebook computer, but may also be a standalone media player or video gaming machine. By way of example, the computer 30D may be an iMac®, a MacBook®, or other similar device by Apple Inc. It should be noted that the computer 30D may also represent a personal computer (e.g., PC) by another manufacturer. A similar enclosure 36 may be provided to protect and enclose internal components of the computer 30D such as the dual-layer

6

display 18. In certain embodiments, a user of the computer 30D may interact with the computer 30D using various peripheral input devices, such as the keyboard 22 or mouse 38, which may connect to the computer 30D via a wired and/or wireless I/O interface 24.

Similarly, FIG. 6 depicts a wearable electronic device 30E representing another embodiment of the electronic device 10 of FIG. 1 that may be configured to operate using the techniques described herein. By way of example, the wearable electronic device 30E, which may include a wristband 43, may be an Apple Watch® by Apple, Inc. However, in other embodiments, the wearable electronic device 30E may include any wearable electronic device such as, for example, a wearable exercise monitoring device (e.g., pedometer, accelerometer, heart rate monitor), or other device by another manufacturer. The display 18 of the wearable electronic device 30E may include a touch screen (e.g., LCD, OLED display, active-matrix organic light emitting diode (e.g., AMOLED) display, and so forth), which may allow users to interact with a user interface of the wearable electronic device 30E.

As mentioned previously, it is often desirable for various electronic devices to communicate with one another. In view of the various disadvantages associated with traditional cabling and wireless solutions, many situations may arise where a conducted RF link represents a desirable alternative to facilitate such communication. Indeed, in a communication scenario that would benefit from relatively high bandwidth and relatively low power consumption, a conducted RF link represents a good option. One such example is illustrated in FIG. 7, where a video that is stored on or is streaming from a tablet computing device 30C is coupled to a television 50 via a conducted RF link 52. In this example, a relatively simple cable may be run between the I/O interface 24 of the tablet computer 30C to an appropriate input of the television 50, as illustrated. Alternatively, a pad 54 may be coupled to an appropriate input of the television 50 by a conducted RF link 52A. The pad 54 may include surface contacts 56 that may interface with surface contacts (not shown) on the back of the tablet computer 30C, or other electronic device, so that the tablet computer 30C may simply be laid upon the pad 54 such that its surface contacts align with the contacts 56 to facilitate the conducted RF communication.

As illustrated in FIG. 8, to provide various communication options, the I/O interface 24 of the electronic device 10 may include a variety of traditional conductive ports 58 as well as a wireless communications device such as a wireless module 60. The wireless module 60 may include one or more wireless cores 61 that may be coupled to one or more antennae 62 and one or more conductive RF ports 64. FIG. 9 illustrates one example of a wireless module 60A, which includes a WiFi/Bluetooth® 2x2 core 61 that feeds three antennas 62A, 62B and 62C and one conducted RF port 64. As can be seen, the WiFi/Bluetooth® core 61 can output a 2.4 GHz signal or Bluetooth® signal from core 0 on line 66, a 2.4 GHz signal from core 1 on line 68, a 5 GHz signal from core 1 on line 70, and a 5 GHz signal from core 0 on line 72. A first switch 74 can deliver the 2.4 GHz WiFi signal or Bluetooth® signal from core 0 through an amplifier 76A to the antenna 62A or through a combiner 78 to the conducted RF port 64. The 2.4 GHz and 5 GHz signals from core 1 on lines 68 and 70 may be delivered through a multiplexor 80 to a second switch 82. The switch 82 may deliver one of these WiFi signals through the combiner 78 to the conducted RF port 64, or through an amplifier 76B to the second

antenna 62B. The 5 GHz signal from core 0 on line 72 may be delivered through an amplifier 76C to the third antenna 62C.

As mentioned previously, one of the advantages of communicating using the conducted RF link is that it may use less power than communicating wirelessly because the RF signal produced by the core 61 may not need to be amplified prior to transmission. Indeed, in some circumstances the RF signal produced by the core 61 may be attenuated using an attenuator 84 prior to transmission via the conducted RF port 64. For example, a -10 dB attenuator may be used. To provide further power savings, the amplifiers 76A, 76B, and/or 76C may be turned off during periods when signals are being provided via the conducted RF port 64 rather than the respective antennas 62A, 62B, and 62C.

The wireless module 60A can operate in different modes, depending upon the positions of the switches 74 and 82. For example, the wireless module 60A can operate in single in, single out (SISO) mode where one link outputs WiFi and the other link outputs Bluetooth®. Alternatively, the wireless module 60 can operate in multiple in, multiple out (MIMO), where both links can output WiFi simultaneously. FIG. 10 illustrates one example in which the first switch 74 is operating the Bluetooth® link in a time division duplex fashion. As illustrated, the switch 74 may be in position 1 while communicating with a wireless mouse and a wireless headset via the antenna 62A, and then switch to position 2 to communicate with a conducted RF accessory via the conducted RF port 64. Similarly, FIG. 11 illustrates a conducted RF accessory running on a WiFi link, such as an Apple wireless direct link (AWDL). In this situation, the second switch 82 is in position 2 while communicating with the home WiFi, and then switches to position 1 to communicate with the conducted RF accessory. In the example illustrated in FIG. 12, at any given time either the conducted RF Bluetooth® accessory is active or WiFi MIMO is active. Similarly, as illustrated in FIG. 13, the WiFi may operate in SISO and the conducted Bluetooth® accessory will operate at the same time.

It should be understood that the wireless module 60A and the manner in which it operates as described with respect to FIGS. 9-13 above represents merely a single set of examples of how the wireless module 60 may be structured and may operate. Indeed, it should be understood that using a 2x2 core 61, the wireless module 60 may include up to four antennas 62 and up to four conducted RF ports 64. Accordingly, as another example, FIG. 14 illustrates a wireless module 60B, which is identical to the wireless module 60A except with the addition of a third switch 88, a second attenuator 84B, and a second conducted RF link 62B. Furthermore, it should be understood that the above examples utilize a single wireless core 61 to perform both wireless and conducted RF functions. However, an electronic device could include a wireless module 60C as illustrated in FIG. 15 that has a wireless core 61 that provides outputs solely to conducted RF links 64A, 64B, 64C and 64D, either with or without an additional wireless core 61 to handle traditional wireless communication.

It should be understood that various configuration scenarios may be envisioned, with respect to the wireless module 60A illustrated in FIG. 9, for example, depending upon which radio is active, the coexistence scenario, and the switch positions, and that these different configuration scenarios can affect the bandwidth or throughput of the wireless links and the conducted RF link. Various configuration scenarios are illustrated in FIGS. 16 and 17. For various active radio scenarios listed in Column I, the charts illus-

trated in FIGS. 16 and 17 demonstrate the type of signals that may be used by an accessory listed in Column II, along with the various coexistence scenarios, throughputs, and switch positions listed in columns III-VIII, respectively.

For the scenario illustrated in Row A, it should be noted that the radio is not active. In other words, no wireless signals are being sent to any of the antennas 62A, 62B, or 62C. Rather, an accessory coupled to the conducted RF port 64 either receives a Bluetooth® signal or a WiFi signal. In the first scenario, switch 74 is in position 2, and switch 82 is in position 3. Hence, the Bluetooth® signal is delivered from the wireless core 61 on line 66 and sent through the combiner 78 and attenuator 84 to the conducted RF port 64. In the second scenario, switch 74 is in position 3 and switch 82 is in position 1. Hence, either the 2.4 GHz WiFi signal on line 68 or the 5 GHz Wifi on line 70 is delivered through the switch 82, the combiner 78, and the attenuator 84 to the conducted RF port 64.

For the scenario illustrated in Row B, the 2.4 GHz WiFi signal is available for transmission on one or more of the antennas 62, while either the Bluetooth® signal, a 2.4 GHz WiFi signal, or a 5 GHz WiFi signal is available to be sent to the conducted RF port 64. In the first scenario, switch 74 is position 2 and the switch 82 is in position 2. Hence, the Bluetooth® signal on line 66 is delivered to the conducted RF port 64, and the 2.4 GHz WiFi signal on line 68 is delivered to the antenna 62B. In the second scenario, the switch 74 toggles between positions 1 and 2, while the switch 82 toggles between positions 2 and 3. When the switches 74 and 82 are in positions 1 and 2 respectively, the Bluetooth® signal on line 66 is delivered to the antenna 62A and a 2.4 GHz WiFi signal on line 68 is delivered to antenna 62B. When the switches 74 and 82 are in positions 2 and 3, respectively, the Bluetooth® signal on line 66 is delivered to the conducted RF port 64, while no signals are delivered any of the antennas 62A-C. It should be noted that the throughput (e.g., bandwidth) speeds in Columns IV-VI is dependent on the duty cycle created by the switches 74 and 82. In the third scenario, the switch 74 toggles between positions 1 and 2, while the switch 82 toggles between positions 2 and 3. When the switches 74 and 82 are in positions 1 and 2, respectively, the 2.4 GHz WiFi signal on line 66 is delivered to the antenna 62A, and the 2.4 GHz WiFi signal on line 68 is delivered to the antenna 62B. When the switches 74 and 82 are in positions 2 and 3, respectively, the 2.4 GHz WiFi signal on line 66 is delivered to the conducted RF port 64, while no signals are received by the antennas 62A-C. Finally, in the fourth scenario, the switch 74 toggles between positions 1 and 3, while the switch 82 toggles between positions 2 and 1. When the switches 74 and 82 are in positions 1 and 2, respectively, the 2.4 GHz WiFi signal on line 66 is delivered to the antenna 62A, while the 5 GHz signal on line 70 is delivered to the antenna 62B. When the switches 74 and 82 are in positions 3 and 1, respectively, the 5 GHz signal on line 70 is delivered to the conducted RF port 64, while no signals are sent to any of the antennas 62A-C.

For the scenario illustrated in Row C, one or more of the antenna 62 will receive a 5 GHz WiFi signal, while the conducted RF port 64 will receive either the Bluetooth® signal, a 2.4 GHz WiFi signal, or a 5 GHz WiFi signal. In the first scenario, the switch 74 is in position 2 and the switch 82 is in position 2. Hence, the Bluetooth® signal on line 66 is delivered to the conducted RF port 64, while the 5 GHz signal on line 70 is delivered to the antenna 62B. In the second scenario, the switch 74 toggles between positions 3 and 2, while the switch 82 toggles between positions 2 and 3. When the switches 74 and 82 are in positions 3 and 2,



respectively, the 5 GHz signal on line 70 is delivered to the antenna 62B and the 5 GHz signal on the line 72 is delivered to the antenna 62C. When the switches 74 and 82 are in positions 2 and 3, respectively, the 2.4 GHz signal on line 66 is delivered to the conducted RF port 64 while the 5 GHz signal on line 72 is delivered to the antenna 62C. In the third scenario, the switch 74 remains in position 3, while the switch 82 toggles between positions 2 and 1. When the switches 74 and 82 are in positions 3 and 2, respectively, the 5 GHz signal on line 70 is delivered to the antenna 62B, while the 5 GHz signal on the line 72 is delivered to the antenna 62C. When the switches 74 and 82 are in positions 3 and 1, respectively, the 5 GHz signal on line 70 is delivered to the conducted RF port 64, while the 5 GHz signal on line 72 is delivered to the antenna 62C.

For the scenario illustrated in Row D, the Bluetooth® signal is available on the antenna 62A, while either the Bluetooth® signal, a 2.4 GHz signal, or a 5 GHz signal is available on the conducted RF port 64. In the first scenario, the switch 74 toggles between positions 1 and 2, while the switch 82 remains in position 3. When the switches 74 and 82 are in positions 1 and 3, respectively, the Bluetooth® signal on line 66 is delivered to the antenna 62A, while no signals are available on the conducted RF port 64 or the antennas 62B and 62C. When the switches 74 and 82 are in positions 2 and 3, respectively, the Bluetooth® signal on line 66 is delivered to the conducted RF port 64, while no signals are sent to any of the antennas 62A-62C. In the second scenario, the switches 74 and 82 remain in positions 1 and 1, respectively. Hence, the Bluetooth® signal on line 66 is delivered to the antenna 62A, while either the 2.4 GHz signal on line 68 or the 5 GHz on line 70 is delivered to the conducted RF port 64.

For the scenario illustrated in Row E, the Bluetooth® signal and a 2.4 GHz WiFi signal are available on the antennas 62, while either the Bluetooth® signal, a 2.4 GHz WiFi signal, or a 5 GHz signal WiFi is available on the conducted RF port 64. In the first scenario, the switch 74 toggles between positions 1, 1, and 2, while the switch 82 toggles between positions 3, 2, and 3. When the switches 74 and 82 are in positions 1 and 3, respectively, either the Bluetooth® signal or the 2.4 GHz signal on line 66 is delivered to the antenna 62A, while no signals are sent to the conducted RF port 64 or the antennas 62B and 62C. When the switches 74 and 82 are in the positions 1 and 2, respectively, either the Bluetooth® signal or the 2.4 GHz signal on line 66 is delivered to the antenna 62A, while the 2.4 GHz signal line 68 is delivered to the antenna 62B. When the switches 74 and 82 are in positions 2 and 3, respectively, the Bluetooth® signal on line 66 is delivered to the conducted RF port 64, while no signals are sent to any of the antennas 62A-C. In the second scenario, the switch 74 toggles between positions 1, 1, and 2, while the switch 82 toggles between positions 3, 2, and 3. When the switches 74 and 82 are in positions 1 and 3, respectively, either the Bluetooth® signal or the 2.4 GHz signal on line 66 is delivered to the antenna 62A, while no signals are sent to the conducted RF port 64 or the antenna 62B or 62C. When the switches 74 and 82 are in positions 1 and 2, respectively, either the Bluetooth® signal or the 2.4 GHz signal on line 66 is delivered to the antenna 62A, while the 2.4 GHz signal on line 68 is delivered to the antenna 62B. When the switches 74 and 82 are in positions 2 and 3, respectively, the 2.4 GHz signal on line 66 is delivered to the conducted RF port 64, while no signals are sent to any of the antennas 62A-C. In the third scenario, the switch 74 toggles between positions 1, 1, and 3, while the switch 82 toggles between positions 3,

2, and 1. When the switches 74 and 82 are in positions 1 and 3, respectively, either the Bluetooth® signal or the 2.4 GHz signal on line 66 is delivered to antenna 62A, while no signals are delivered to the conducted RF port 64 or antennas 62B and 62C. When the switches 74 and 82 are in positions 1 and 2, respectively, the Bluetooth® signal on line 66 is delivered to the antenna 62A, while the 5 GHz signal on line 70 is delivered to the antenna 62B. When the switches 74 and 82 are in positions 3 and 1, respectively, the 5 GHz signal on line 70 is delivered to the conducted RF port 64, while no signals are delivered to the antennas 62A-62C.

For the scenario illustrated in Row F, the Bluetooth® signal and a 5 GHz WiFi signal are available on the antennas 62, while either the Bluetooth® signal, a 2.4 GHz WiFi signal, or a 5 GHz signal WiFi is available on the conducted RF port 64. In the first scenario, the switch 74 toggles between positions 1, 1, and 2, while the switch 82 remains in position 2. When the switches 74 and 82 are in positions 1 and 2, respectively, the Bluetooth® signal on line 66 is delivered to the antenna 62A, while the 5 GHz signal on line 70 is sent to the antenna 62B and the 5 GHz signal on line 72 is delivered to the antenna 62C. When the switches 74 and 82 are in the positions 1 and 2, respectively, in the next phase, the Bluetooth® signal on line 66 is delivered to the antenna 62A, while the 5 GHz signal line 70 is delivered to the antenna 62B and the 5 GHz signal on line 72 is delivered to the antenna 62C. When the switches 74 and 82 are in positions 2 and 2, respectively, the Bluetooth® signal on line 66 is delivered to the conducted RF port 64, and the 5 GHz signal on line 70 is delivered to the antenna 62B and the 5 GHz signal on line 72 is delivered to the antenna 62C. In the second scenario, the switch 74 remains in position 1, while the switch 82 toggles between positions 2, 2, and 1. When the switches 74 and 82 are in positions 1 and 2, respectively, the Bluetooth® signal on line 66 is delivered to the antenna 62A, the 5 GHz signal on line 70 is delivered to the antenna 62B and the 5 GHz signal on line 72 is delivered to the antenna 62C. When the switches 74 and 82 are in positions 1 and 2, respectively, in the next phase, the Bluetooth® signal on line 66 is delivered to the antenna 62A, while the 5 GHz signal on line 70 is delivered to the antenna 62B and the 5 GHz signal on line 72 is delivered to the antenna 62C. When the switches 74 and 82 are in positions 1 and 1, respectively, the Bluetooth® signal on line 66 is delivered to the antenna 62A, while the 2.4 GHz signal on line 68 is delivered to the conducted RF port 64. In the third scenario, the switch 74 remains in position 1, while the switch 82 toggles between positions 2, 2, and 1. When the switches 74 and 82 are in positions 1 and 2, respectively, the Bluetooth® signal on line 66 is delivered to antenna 62A, while the 5 GHz signal on line 70 is delivered to the antenna 62B and the 5 GHz signal on line 72 is delivered to the antenna 62C. When the switches 74 and 82 are in positions 1 and 2, respectively, in the next phase, the Bluetooth® signal on line 66 is delivered to the antenna 62A, while the 5 GHz signal on line 70 is delivered to the antenna 62B and the 5 GHz signal on line 72 is delivered to the antenna 62C. When the switches 74 and 82 are in positions 1 and 1, respectively, the Bluetooth® signal on line 66 is delivered to antenna 62A, while the 5 GHz signal on line 70 is delivered to the conducted RF port 64.

Finally, it should be understood that the accessories that may be used to communicate with the electronic device via the conducted RF link 64 may include a suitable demodulator that receives the modulated analog RF signal and demodulates it to recover the digital signal that is being transmitted between the devices, as well as a suitable

## 11

modulator for converting digital data to a modulated analog RF signal so that it can be transmitted back to the device **10** via a conducted RF link. Similarly, although it is not shown, the wireless module **60** may include a demodulator for receiving the RF signal transmitted back to the electronic device **10** from the accessory.

The specific embodiments described above have been shown by way of example, and it should be understood that these embodiments may be susceptible to various modifications and alternative forms. It should be further understood that the claims are not intended to be limited to the particular forms disclosed, but rather to cover all modifications, equivalents, and alternatives falling within the spirit and scope of this disclosure.

What is claimed is:

**1.** A communications apparatus comprising:  
a wireless communications device configured to generate a radio frequency (RF) signal onto a conductor; and  
a conducted RF port operably coupled to the conductor, the conducted RF port being configured to conductively couple the RF signal on the conductor to another device.

**2.** The communications apparatus, as set forth in claim **1**, wherein the wireless communications device comprises a cellular device.

**3.** The communications apparatus, as set forth in claim **1**, wherein the wireless communications device comprises a WiFi device.

**4.** The communications apparatus, as set forth in claim **1**, wherein the wireless communications device comprises a Bluetooth device.

**5.** The communications apparatus, as set forth in claim **1**, wherein the wireless communications device comprises a wireless module having a WiFi core and a Bluetooth core.

**6.** The communications apparatus, as set forth in claim **5**, wherein the wireless module comprises a first WiFi output and a first Bluetooth output, and wherein the communications apparatus comprises a first switch coupled to the first WiFi output and the first Bluetooth output to direct either a first WiFi signal on the first WiFi output or a first Bluetooth signal on the first Bluetooth output to the conducted RF port.

**7.** The communications apparatus, as set forth in claim **6**, wherein the wireless module comprises a second WiFi output and a third WiFi output, and wherein the communications apparatus comprises a second switch coupled to the second WiFi output and the third WiFi output to direct either a second WiFi signal on the second WiFi output or a third WiFi signal on the third WiFi output to an antenna.

**8.** The communications apparatus, as set forth in claim **6**, comprising a first antenna, and wherein the first switch is coupled to the first WiFi output and the first Bluetooth output to direct either the first WiFi signal on the first WiFi output or the first Bluetooth signal on the first Bluetooth output to the conducted RF port when the first switch is in a first position and to direct either the first WiFi signal on the first WiFi output or the first Bluetooth signal on the first Bluetooth output to the first antenna when the first switch is in a second position.

**9.** The communications apparatus, as set forth in claim **8**, wherein the wireless module comprises a second WiFi output and a third WiFi output, and wherein the communications apparatus comprises a second antenna, a third antenna, and a second switch, wherein the second switch is coupled to the second WiFi output and the third WiFi output to direct either a second WiFi signal on the second WiFi output or a third WiFi signal on the WiFi output to the second antenna when the second switch is in a first position

## 12

and to direct either the second WiFi signal on the second WiFi output or the third WiFi signal on the third WiFi output to the third antenna when the second switch is in a second position.

**10.** The communications apparatus, as set forth in claim **1**, wherein the wireless communications device is configured to generate a plurality of radio frequency (RF) signals onto a plurality of conductors, and

wherein the communications apparatus comprises a plurality of conducted RF ports operably coupled to respective conductors, the plurality of conducted RF ports being configured to conductively couple the plurality of RF signals on the conductors to other devices.

**11.** A communications method comprising:

using a wireless communications device to generate a radio frequency (RF) signal onto a conductor; and  
using a conducted RF port operably coupled to the conductor to conductively couple the RF signal on the conductor to another device.

**12.** The communications method, as set forth in claim **11**, wherein the wireless communications device comprises a cellular device.

**13.** The communications method, as set forth in claim **11**, wherein the wireless communications device comprises a WiFi device.

**14.** The communications method, as set forth in claim **11**, wherein the wireless communications device comprises a Bluetooth device.

**15.** The communications method, as set forth in claim **11**, wherein the wireless communications device comprises a wireless module having a WiFi core and a Bluetooth core.

**16.** The communications method, as set forth in claim **15**, wherein the wireless module comprises a first WiFi output and a first Bluetooth output, and wherein the communications method comprises using a first switch coupled to the first WiFi output and the first Bluetooth output to direct either a first WiFi signal on the first WiFi output or a first Bluetooth signal on the first Bluetooth output to the conducted RF port.

**17.** The communications method, as set forth in claim **16**, wherein the wireless module comprises a second WiFi output and a third WiFi output, and wherein the communications method comprises using a second switch coupled to the second WiFi output and the third WiFi output to direct either a second WiFi signal on the second WiFi output or a third WiFi signal on the third WiFi output to an antenna.

**18.** The communications method, as set forth in claim **16**, comprising a first antenna, and wherein the communications method comprises using the first switch to direct either the first WiFi signal on the first WiFi output or the first Bluetooth signal on the first Bluetooth output to the conducted RF port when the first switch is in a first position and to direct either the first WiFi signal on the first WiFi output or the first Bluetooth signal on the first Bluetooth output to the first antenna when the first switch is in a second position.

**19.** The communications method, as set forth in claim **18**, wherein the wireless module comprises a second WiFi output and a third WiFi output, and wherein the communications method comprises a second switch coupled to the second WiFi output and the third WiFi output to direct either a second WiFi signal on the second WiFi output or a third WiFi signal on the WiFi output to a second antenna when the second switch is in a first position and to direct either the second WiFi signal on the second WiFi output or the third WiFi signal on the third WiFi output to a third antenna when the second switch is in a second position.

20. The communications method, as set forth in claim 11, comprising:

using the wireless communications device to generate a plurality of radio frequency (RF) signals onto a plurality of conductors; and

5

using a plurality of conducted RF ports operably coupled to respective conductors to conductively couple the plurality of RF signals on the conductors to other devices.

\* \* \* \* \*

10