



US009707711B2

(12) **United States Patent**
Trude et al.

(10) **Patent No.:** **US 9,707,711 B2**
(45) **Date of Patent:** ***Jul. 18, 2017**

(54) **CONTAINER HAVING OUTWARDLY BLOWN, INVERTIBLE DEEP-SET GRIPS**

(75) Inventors: **Gregory Trude**, Clarks Summit, PA (US); **Paul Kelley**, Wrightsville, PA (US)

(73) Assignee: **GRAHAM PACKAGING COMPANY, L.P.**, York, PA (US)

(*) Notice: Subject to any disclaimer, the term of this patent is extended or adjusted under 35 U.S.C. 154(b) by 820 days.

This patent is subject to a terminal disclaimer.

(21) Appl. No.: **13/453,993**

(22) Filed: **Apr. 23, 2012**

(65) **Prior Publication Data**

US 2012/0267381 A1 Oct. 25, 2012

Related U.S. Application Data

(60) Continuation-in-part of application No. 12/627,922, filed on Nov. 30, 2009, now Pat. No. 8,162,655, (Continued)

(51) **Int. Cl.**
B29C 49/32 (2006.01)
B29C 49/48 (2006.01)
(Continued)

(52) **U.S. Cl.**
CPC **B29C 49/4802** (2013.01); **B29C 49/54** (2013.01); **B65D 23/102** (2013.01);
(Continued)

(58) **Field of Classification Search**
CPC **B29C 49/4802**; **B65D 23/102**
(Continued)

(56) **References Cited**

U.S. PATENT DOCUMENTS

D1,665 S * 10/1862 Robinson D9/560
1,499,239 A 6/1924 Malmquist
(Continued)

FOREIGN PATENT DOCUMENTS

AU 2002257159 B2 4/2003
CA 2077717 A1 3/1993
(Continued)

OTHER PUBLICATIONS

U.S. Appl. No. 60/220,326, filed Jul. 24, 2000.
(Continued)

Primary Examiner — Anthony Stashick
Assistant Examiner — Raven Collins
(74) *Attorney, Agent, or Firm* — Baker Botts L.L.P.

(57) **ABSTRACT**

A container forming assembly and method includes receiving a parison within a cavity of a mold, enclosing the parison within the mold having a wall with a recess, inflating the parison in the mold to form a blow molded container where the blow molded container has a sidewall, a movable region formed at the recess, and a hinge circumscribing an interface between the sidewall and the movable region, and moving or repositioning the movable region toward an interior of the blow molded container about the hinge before filling. The movable region can form a deep-set grip. Further, multiple movable regions can be provided, each of which may form respective deep-set grips. The container shape can be symmetrical or asymmetrical.

17 Claims, 22 Drawing Sheets

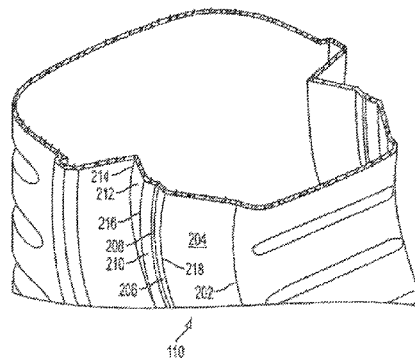
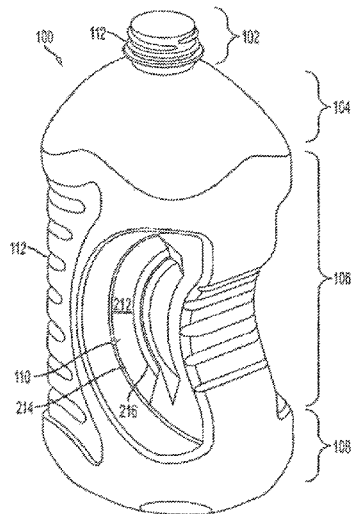

Related U.S. Application Data

which is a division of application No. 11/399,430, filed on Apr. 7, 2006, now Pat. No. 8,017,065.

(51) **Int. Cl.**

- B29C 49/54* (2006.01)
- B65D 23/10* (2006.01)
- B29C 49/06* (2006.01)
- B29C 49/22* (2006.01)
- B29K 23/00* (2006.01)
- B29K 67/00* (2006.01)
- B29K 77/00* (2006.01)
- B29L 31/46* (2006.01)
- B29L 31/00* (2006.01)

(52) **U.S. Cl.**

- CPC *B29B 2911/1402* (2013.01); *B29B 2911/1404* (2013.01); *B29B 2911/14026* (2013.01); *B29B 2911/14033* (2013.01); *B29C 49/06* (2013.01); *B29C 49/22* (2013.01); *B29K 2023/06* (2013.01); *B29K 2023/065* (2013.01); *B29K 2023/0633* (2013.01); *B29K 2023/086* (2013.01); *B29K 2067/00* (2013.01); *B29K 2077/00* (2013.01); *B29L 2031/463* (2013.01); *B29L 2031/7158* (2013.01)

(58) **Field of Classification Search**

- USPC 215/379–385, 397; 220/669, 760, 773; D9/532, 541–543, 559, 569–572
- See application file for complete search history.

(56)

References Cited

U.S. PATENT DOCUMENTS

2,142,257 A 1/1937 Saeta
D110,624 S 7/1938 Mekeel, Jr.
2,124,959 A 7/1938 Vogel
2,378,324 A 6/1945 Ray et al.
2,880,902 A 4/1959 Owsen
2,960,248 A 11/1960 Kuhlman
2,971,671 A 2/1961 Shakman
2,982,440 A 5/1961 Harrison
D192,535 S * 4/1962 Laudano D9/543
3,043,461 A 7/1962 Glassco
3,081,002 A 3/1963 Tauschinski et al.
3,090,478 A 5/1963 Stanley
3,142,371 A 7/1964 Rice et al.
3,174,655 A 3/1965 Hurschman
3,198,861 A 8/1965 Marvel
3,201,111 A 8/1965 Afton
3,301,293 A 1/1967 Santelli
3,325,031 A * 6/1967 Singier 215/247
3,397,724 A 8/1968 Bolen et al.
3,409,167 A 11/1968 Blanchard
3,417,893 A 12/1968 Lieberman
3,426,939 A 2/1969 Young
3,441,982 A 5/1969 Tsukahara et al.
3,468,443 A 9/1969 Marcus
3,483,908 A 12/1969 Donovan
3,485,355 A 12/1969 Stewart
D217,439 S * 5/1970 Platte D9/543
D219,366 S * 12/1970 Lewis, Jr. et al. D9/532
3,693,828 A 9/1972 Kneusel et al.
3,704,140 A 11/1972 Petit et al.
3,727,783 A 4/1973 Carmichael
3,791,508 A 2/1974 Osborne et al.
D231,904 S * 6/1974 Boden D9/543
3,819,789 A 6/1974 Parker
3,904,069 A 9/1975 Toukmanian
3,918,920 A 11/1975 Barber
3,935,955 A 2/1976 Das
3,941,237 A 3/1976 MacGregor, Jr.
3,942,673 A 3/1976 Lyu et al.

3,949,033 A 4/1976 Uhlig
3,956,441 A 5/1976 Uhlig
4,035,455 A 7/1977 Rosenkranz et al.
4,036,926 A 7/1977 Chang
4,037,752 A 7/1977 Dulmaine et al.
4,117,062 A 9/1978 Uhlig
4,123,217 A 10/1978 Fischer et al.
4,125,632 A 11/1978 Vosti et al.
4,134,510 A 1/1979 Chang
4,158,624 A 6/1979 Ford et al.
4,170,622 A 10/1979 Uhlig
4,174,782 A 11/1979 Obsomer
4,177,239 A 12/1979 Gittner et al.
4,219,137 A 8/1980 Hutchens
4,231,483 A 11/1980 Dechenne et al.
4,247,012 A 1/1981 Alberghini
D258,117 S * 2/1981 Bashour D9/543
4,301,933 A 11/1981 Yoshino et al.
D262,267 S * 12/1981 Cox D9/543
4,318,489 A 3/1982 Snyder et al.
4,318,882 A 3/1982 Agrawal et al.
4,338,765 A 7/1982 Ohmori et al.
4,355,728 A 10/1982 Ota et al.
4,377,191 A 3/1983 Yamaguchi
4,378,328 A 3/1983 Przytulla et al.
4,381,061 A 4/1983 Cerny et al.
D269,158 S 5/1983 Gaunt et al.
4,386,701 A 6/1983 Galer
4,436,216 A 3/1984 Chang
4,444,308 A 4/1984 MacEwen
4,450,878 A 5/1984 Takada et al.
4,465,199 A 8/1984 Aoki
4,495,974 A 1/1985 Pohorski
D277,551 S * 2/1985 Kerr D9/543
4,497,621 A 2/1985 Kudert et al.
4,497,855 A 2/1985 Agrawal et al.
4,525,401 A 6/1985 Pocock et al.
4,542,029 A 9/1985 Caner et al.
4,547,333 A 10/1985 Takada
4,585,158 A 4/1986 Wardlaw, III
4,610,366 A 9/1986 Estes et al.
4,628,669 A 12/1986 Herron et al.
4,642,968 A 2/1987 McHenry et al.
4,645,078 A 2/1987 Reyner
4,667,454 A 5/1987 McHenry et al.
4,684,025 A 8/1987 Copland et al.
4,685,273 A 8/1987 Caner et al.
D292,378 S 10/1987 Brandt et al.
4,701,121 A 10/1987 Jakobsen et al.
4,723,661 A 2/1988 Hoppmann et al.
4,724,855 A 2/1988 Jackson
4,725,464 A 2/1988 Collette
4,747,507 A 5/1988 Fitzgerald et al.
4,749,092 A 6/1988 Sugiura et al.
4,769,206 A 9/1988 Reymann et al.
4,773,458 A 9/1988 Touzani
4,785,949 A 11/1988 Krishnakumar et al.
4,785,950 A 11/1988 Miller et al.
4,804,097 A * 2/1989 Alberghini et al. 215/384
4,807,424 A 2/1989 Robinson et al.
4,813,556 A 3/1989 Lawrence
4,831,050 A 5/1989 Cassidy et al.
4,836,398 A 6/1989 Leftault, Jr. et al.
4,840,289 A 6/1989 Fait et al.
4,850,493 A 7/1989 Howard, Jr.
4,850,494 A 7/1989 Howard, Jr.
4,865,206 A 9/1989 Behm et al.
4,867,323 A 9/1989 Powers
4,880,129 A 11/1989 McHenry et al.
4,887,730 A 12/1989 Touzani
4,890,752 A * 1/1990 Ota et al. 215/384
4,892,205 A 1/1990 Powers et al.
4,896,205 A 1/1990 Weber
4,921,147 A 5/1990 Poirier
4,927,679 A 5/1990 Beck
4,962,863 A 10/1990 Wendling et al.
4,967,538 A 11/1990 Leftault, Jr. et al.
4,978,015 A 12/1990 Walker
4,993,565 A * 2/1991 Ota et al. 215/384

(56)

References Cited

U.S. PATENT DOCUMENTS

4,997,692	A	3/1991	Yoshino		5,758,790	A	*	6/1998	Ewing, Jr.	215/384
5,004,109	A	4/1991	Bartley et al.		5,758,802	A		6/1998	Wallays	
5,005,716	A	4/1991	Eberle		5,762,221	A		6/1998	Tobias et al.	
5,014,868	A	5/1991	Wittig et al.		5,780,130	A		7/1998	Hansen et al.	
5,020,691	A	6/1991	Nye		5,785,197	A		7/1998	Slat	
5,024,340	A	6/1991	Alberghini et al.		5,819,507	A		10/1998	Kaneko et al.	
5,033,254	A	7/1991	Zenger		5,829,614	A		11/1998	Collette et al.	
5,054,632	A	10/1991	Alberghini et al.		5,833,115	A	*	11/1998	Eiten	220/669
5,060,453	A	10/1991	Alberghini et al.		D402,896	S	*	12/1998	Conrad	D9/543
5,067,622	A	11/1991	Garver et al.		5,860,556	A		1/1999	Robbins, III	
5,090,180	A	2/1992	Sorensen		5,868,272	A	*	2/1999	Deal	220/669
5,092,474	A	3/1992	Leigner		5,887,739	A		3/1999	Prevot et al.	
5,122,327	A	6/1992	Spina et al.		5,888,598	A		3/1999	Brewster et al.	
5,133,468	A	7/1992	Brunson et al.		5,897,090	A		4/1999	Smith et al.	
5,141,120	A	* 8/1992	Brown et al.	215/381	5,906,286	A		5/1999	Matsuno et al.	
5,141,121	A	* 8/1992	Brown et al.	215/381	5,908,128	A		6/1999	Krishnakumar et al.	
5,148,930	A	* 9/1992	Ota et al.	215/384	D413,519	S		9/1999	Eberle et al.	
5,165,557	A	* 11/1992	Ota et al.	215/384	D415,030	S		10/1999	Searle et al.	
5,178,290	A	1/1993	Ota et al.		5,971,184	A		10/1999	Krishnakumar et al.	
5,199,587	A	* 4/1993	Ota et al.	215/381	5,976,653	A		11/1999	Collette et al.	
5,199,588	A	* 4/1993	Hayashi	215/381	5,979,696	A	*	11/1999	Bode et al.	220/675
5,201,438	A	4/1993	Norwood		5,989,661	A		11/1999	Krishnakumar et al.	
5,217,737	A	6/1993	Gygax et al.		6,016,932	A		1/2000	Gaydosh et al.	
5,222,615	A	* 6/1993	Ota et al.	215/375	RE36,639	E		4/2000	Okhai	
5,224,614	A	* 7/1993	Bono et al.	215/384	6,045,001	A		4/2000	Seul	
5,226,550	A	* 7/1993	Mikolaitis et al.	215/384	6,051,295	A		4/2000	Schloss et al.	
5,234,126	A	8/1993	Jonas et al.		6,063,325	A		5/2000	Nahill et al.	
5,244,106	A	9/1993	Takacs		6,065,624	A		5/2000	Steinke	
5,251,424	A	10/1993	Zenger et al.		6,068,110	A		5/2000	Kumakiri et al.	
5,255,889	A	10/1993	Collette et al.		6,074,596	A		6/2000	Jacquet	
5,261,543	A	* 11/1993	Ugarelli	215/375	6,077,554	A		6/2000	Wiemann et al.	
5,261,544	A	11/1993	Weaver, Jr.		6,090,334	A		7/2000	Matsuno et al.	
5,279,433	A	1/1994	Krishnakumar et al.		6,105,815	A		8/2000	Mazda	
5,281,387	A	1/1994	Collette et al.		6,113,377	A		9/2000	Clark	
5,303,834	A	* 4/1994	Krishnakumar et al.	215/381	D431,470	S	*	10/2000	Henderson	D9/520
5,310,043	A	5/1994	Alcorn		D433,946	S		11/2000	Rollend et al.	
5,333,761	A	8/1994	Davis et al.		6,164,474	A	*	12/2000	Cheng et al.	215/384
5,337,909	A	8/1994	Vaillencourt		6,176,382	B1		1/2001	Bazlur Rashid	
5,337,924	A	* 8/1994	Dickie	222/212	D440,877	S		4/2001	Lichtman et al.	
5,341,946	A	8/1994	Vaillencourt et al.		6,209,710	B1		4/2001	Mueller et al.	
5,381,910	A	* 1/1995	Sugiura et al.	215/398	6,213,325	B1		4/2001	Cheng et al.	
5,385,250	A	* 1/1995	Pasquale	215/374	6,217,818	B1		4/2001	Collette et al.	
5,389,332	A	2/1995	Amari et al.		6,228,317	B1		5/2001	Smith et al.	
5,392,937	A	* 2/1995	Prevot et al.	215/400	6,230,912	B1		5/2001	Rashid	
5,405,015	A	4/1995	Bhatia et al.		6,248,413	B1		6/2001	Barel et al.	
5,407,086	A	4/1995	Ota et al.		6,253,809	B1		7/2001	Paradies	
5,411,699	A	5/1995	Collette et al.		6,273,282	B1		8/2001	Ogg et al.	
5,454,481	A	10/1995	Hsu		6,277,321	B1	*	8/2001	Vaillencourt et al.	264/529
5,472,105	A	* 12/1995	Krishnakumar et al.	215/384	D449,538	S	*	10/2001	Burleson et al.	D9/530
5,472,181	A	12/1995	Lowell		6,298,638	B1		10/2001	Bettle	
RE35,140	E	1/1996	Powers, Jr.		D450,595	S		11/2001	Ogg et al.	
5,484,052	A	1/1996	Pawloski et al.		6,349,839	B1	*	2/2002	Mooney	215/384
D366,831	S	2/1996	Semersky et al.		6,354,427	B1		3/2002	Pickel et al.	
5,503,283	A	4/1996	Semersky		6,375,025	B1	*	4/2002	Mooney	215/384
5,543,107	A	8/1996	Malik et al.		6,390,316	B1		5/2002	Mooney	
5,579,937	A	* 12/1996	Valyi	215/384	6,398,052	B1	*	6/2002	Cheng et al.	215/384
5,593,063	A	1/1997	Claydon et al.		6,413,466	B1		7/2002	Boyd et al.	
5,598,941	A	* 2/1997	Semersky et al.	215/384	6,439,413	B1		8/2002	Prevot et al.	
5,632,397	A	5/1997	Fandoux et al.		6,460,714	B1		10/2002	Silvers et al.	
5,637,167	A	* 6/1997	Krishnakumar et al.	156/85	6,467,639	B2	*	10/2002	Mooney	215/384
5,642,826	A	7/1997	Melrose		6,485,669	B1		11/2002	Boyd et al.	
D382,807	S	* 8/1997	Silvers et al.	D9/520	6,494,333	B2		12/2002	Sasaki et al.	
5,672,730	A	9/1997	Cottman		6,502,369	B1		1/2003	Andison et al.	
5,687,874	A	11/1997	Omori et al.		6,514,451	B1		2/2003	Boyd et al.	
5,690,244	A	11/1997	Darr		6,585,123	B1		7/2003	Pedmo et al.	
5,697,489	A	12/1997	Deonarine et al.		6,585,124	B2		7/2003	Boyd et al.	
5,704,504	A	1/1998	Bueno		6,595,380	B2		7/2003	Silvers	
D390,114	S	* 2/1998	Young	D9/520	6,612,451	B2		9/2003	Tobias et al.	
5,713,480	A	2/1998	Petre et al.		6,616,001	B2	*	9/2003	Saito et al.	215/381
5,718,030	A	2/1998	Langmack et al.		6,635,217	B1		10/2003	Britton	
D391,854	S	* 3/1998	Ankney et al.	D9/520	D482,976	S		12/2003	Melrose	
5,730,314	A	3/1998	Wiemann et al.		6,659,300	B2	*	12/2003	Wurster et al.	215/379
5,730,914	A	3/1998	Ruppman, Sr.		6,662,960	B2		12/2003	Hong et al.	
5,735,420	A	4/1998	Nakamaki et al.		6,676,883	B2		1/2004	Hutchinson et al.	
5,737,827	A	4/1998	Kuse et al.		6,698,606	B2	*	3/2004	Deubel et al.	215/384
					6,739,467	B2	*	5/2004	Saito et al.	215/384
					D492,201	S		6/2004	Pritchett et al.	
					6,749,075	B2		6/2004	Bourque et al.	
					6,749,780	B2		6/2004	Tobias	

(56)

References Cited

U.S. PATENT DOCUMENTS

6,763,968	B1	7/2004	Boyd et al.	8,171,701	B2	5/2012	Kelley et al.
6,763,969	B1	7/2004	Melrose et al.	8,235,704	B2	8/2012	Kelley
6,769,561	B2	8/2004	Futral et al.	8,323,555	B2	12/2012	Trude et al.
6,779,673	B2	8/2004	Melrose et al.	2001/0030167	A1*	10/2001	Mooney 215/384
6,796,450	B2	9/2004	Prevot et al.	2001/0035391	A1	11/2001	Young et al.
6,814,248	B2*	11/2004	Beck et al. 215/384	2002/0063105	A1	5/2002	Darr et al.
6,841,262	B1*	1/2005	Beck et al. 428/542.8	2002/0074336	A1	6/2002	Silvers
6,920,992	B2	7/2005	Lane et al.	2002/0096486	A1	7/2002	Bourque et al.
D508,410	S*	8/2005	Zboch et al. D9/667	2002/0153343	A1	10/2002	Tobias et al.
6,923,334	B2	8/2005	Melrose et al.	2002/0158038	A1	10/2002	Heisel et al.
6,929,138	B2	8/2005	Melrose et al.	2002/0162819	A1*	11/2002	Saito et al. 215/384
6,932,230	B2	8/2005	Pedmo et al.	2003/0015491	A1	1/2003	Melrose et al.
D509,984	S*	9/2005	Zboch et al. D9/667	2003/0075521	A1*	4/2003	Miura 215/384
6,942,116	B2	9/2005	Lisch et al.	2003/0186006	A1	10/2003	Schmidt et al.
6,964,347	B2*	11/2005	Miura 215/384	2003/0196926	A1	10/2003	Tobias et al.
6,974,047	B2	12/2005	Kelley et al.	2003/0205550	A1	11/2003	Prevot et al.
6,983,858	B2	1/2006	Slat et al.	2003/0217947	A1	11/2003	Ishikawa et al.
7,051,073	B1	5/2006	Dutta	2004/0000533	A1	1/2004	Kaimieni et al.
7,051,889	B2	5/2006	Boukobza	2004/0016716	A1	1/2004	Melrose et al.
D522,368	S	6/2006	Darr et al.	2004/0026357	A1*	2/2004	Beck et al. 215/384
7,073,675	B2	7/2006	Trude	2004/0074864	A1	4/2004	Melrose et al.
7,077,279	B2	7/2006	Melrose	2004/0129669	A1	7/2004	Kelley et al.
7,080,746	B2*	7/2006	Saito et al. 215/381	2004/0149677	A1	8/2004	Slat et al.
7,080,747	B2	7/2006	Lane et al.	2004/0173565	A1	9/2004	Semersky et al.
7,080,748	B2*	7/2006	Sasaki et al. 215/384	2004/0211746	A1	10/2004	Trude
7,097,059	B2*	8/2006	Saito et al. 215/383	2004/0232103	A1	11/2004	Lisch et al.
7,097,060	B2*	8/2006	Penny et al. 215/384	2005/0035083	A1	2/2005	Pedmo et al.
7,097,061	B2*	8/2006	Simpson et al. 215/396	2005/0035084	A1*	2/2005	Simpson et al. 215/396
7,118,002	B2*	10/2006	Saito et al. 215/384	2005/0121408	A1*	6/2005	Deemer et al. 215/381
D531,910	S	11/2006	Melrose	2005/0121409	A1*	6/2005	Penny et al. 215/384
7,137,520	B1	11/2006	Melrose	2005/0211662	A1	9/2005	Eaton et al.
7,140,505	B2	11/2006	Roubal et al.	2005/0218107	A1*	10/2005	Sabold et al. 215/382
7,150,372	B2	12/2006	Lisch et al.	2005/0218108	A1	10/2005	Banai et al.
D535,884	S	1/2007	Davis et al.	2005/0252881	A1*	11/2005	Zhang et al. 215/384
7,159,374	B2	1/2007	Abercrombie, III et al.	2006/0006133	A1	1/2006	Lisch et al.
7,159,729	B2*	1/2007	Sabold et al. 215/382	2006/0051541	A1	3/2006	Steele
D538,168	S	3/2007	Davis et al.	2006/0138074	A1	6/2006	Melrose
7,191,910	B2*	3/2007	Deemer et al. 215/381	2006/0147664	A1	7/2006	Richards et al.
D547,664	S	7/2007	Davis et al.	2006/0151425	A1	7/2006	Kelley et al.
7,296,703	B2*	11/2007	Lane 215/384	2006/0231985	A1	10/2006	Kelley
7,334,695	B2	2/2008	Bysick et al.	2006/0243698	A1	11/2006	Melrose
7,347,339	B2*	3/2008	Bangi et al. 215/381	2006/0249477	A1*	11/2006	Simpson et al. 215/384
7,350,657	B2	4/2008	Eaton et al.	2006/0255005	A1	11/2006	Melrose et al.
D572,599	S	7/2008	Melrose	2006/0261031	A1	11/2006	Melrose
7,416,088	B2	8/2008	Boukobza	2007/0017892	A1	1/2007	Melrose
7,416,089	B2	8/2008	Kraft et al.	2007/0045222	A1	3/2007	Denner et al.
D576,041	S	9/2008	Melrose et al.	2007/0045223	A1*	3/2007	Noll et al. 215/384
7,451,886	B2	11/2008	Lisch et al.	2007/0045312	A1	3/2007	Abercrombie, III et al.
7,481,325	B2*	1/2009	Simpson et al. 215/384	2007/0051073	A1	3/2007	Kelley et al.
7,543,713	B2	6/2009	Trude et al.	2007/0084821	A1	4/2007	Bysick et al.
7,552,834	B2	6/2009	Tanaka et al.	2007/0125742	A1	6/2007	Simpson, Jr. et al.
7,574,846	B2	8/2009	Sheets et al.	2007/0125743	A1	6/2007	Pritchett, Jr. et al.
7,694,842	B2	4/2010	Melrose	2007/0131644	A1	6/2007	Melrose
7,726,106	B2	6/2010	Kelley et al.	2007/0181403	A1	8/2007	Sheets et al.
7,735,304	B2	6/2010	Kelley et al.	2007/0187355	A1*	8/2007	Kamineneni 215/384
7,748,551	B2	7/2010	Gatewood et al.	2007/0199915	A1	8/2007	Denner et al.
D623,952	S	9/2010	Yourist et al.	2007/0199916	A1	8/2007	Denner et al.
7,799,264	B2	9/2010	Trude	2007/0215571	A1	9/2007	Trude
7,882,971	B2	2/2011	Kelley et al.	2007/0235905	A1	10/2007	Trude et al.
7,900,425	B2	3/2011	Bysick et al.	2008/0029475	A1	2/2008	Scarola
7,926,243	B2	4/2011	Kelley et al.	2008/0047964	A1	2/2008	Denner et al.
D637,495	S	5/2011	Gill et al.	2008/0087628	A1*	4/2008	Bangi et al. 215/384
D637,913	S	5/2011	Schlies et al.	2008/0156847	A1	7/2008	Hawk et al.
D641,244	S	7/2011	Bysick et al.	2008/0257856	A1	10/2008	Melrose et al.
7,980,404	B2	7/2011	Trude et al.	2009/0090728	A1	4/2009	Trude et al.
8,011,166	B2	9/2011	Sheets et al.	2009/0091067	A1	4/2009	Trude et al.
8,017,065	B2	9/2011	Trude et al.	2009/0092720	A1	4/2009	Trude et al.
D646,966	S	10/2011	Gill et al.	2009/0120530	A1	5/2009	Kelley et al.
8,028,498	B2	10/2011	Melrose	2009/0134117	A1	5/2009	Mooney
8,075,833	B2	12/2011	Kelley	2009/0202766	A1	8/2009	Beuerle et al.
D653,119	S	1/2012	Hunter et al.	2009/0293436	A1	12/2009	Miyazaki et al.
8,096,098	B2	1/2012	Kelley et al.	2010/0018838	A1	1/2010	Kelley et al.
D653,550	S	2/2012	Hunter	2010/0116778	A1	5/2010	Melrose
D653,957	S	2/2012	Yourist et al.	2010/0133228	A1	6/2010	Trude
8,162,655	B2	4/2012	Trude et al.	2010/0163513	A1	7/2010	Pedmo
				2010/0170199	A1	7/2010	Kelley et al.
				2010/0213204	A1	8/2010	Melrose
				2010/0237083	A1	9/2010	Trude et al.
				2010/0301058	A1	12/2010	Trude et al.

(56)

References Cited

U.S. PATENT DOCUMENTS

2011/0049083 A1 3/2011 Scott et al.
 2011/0049084 A1 3/2011 Yourist et al.
 2011/0084046 A1 4/2011 Schlies et al.
 2011/0094618 A1 4/2011 Melrose
 2011/0108515 A1 5/2011 Gill et al.
 2011/0113731 A1 5/2011 Bysick et al.
 2011/0132865 A1 6/2011 Hunter et al.
 2011/0147392 A1 6/2011 Trude et al.
 2011/0210133 A1 9/2011 Melrose et al.
 2011/0266293 A1 11/2011 Kelley et al.
 2011/0284493 A1 11/2011 Yourist et al.
 2012/0104010 A1 5/2012 Kelley
 2012/0107541 A1 5/2012 Nahill et al.
 2012/0132611 A1 5/2012 Trude et al.
 2012/0152964 A1 6/2012 Kelley et al.
 2012/0240515 A1 9/2012 Kelley et al.
 2012/0266565 A1 10/2012 Trude et al.
 2013/0000259 A1 1/2013 Trude et al.

FOREIGN PATENT DOCUMENTS

DE 1761753 1/1972
 DE P2102319.8 8/1972
 DE 3215866 A1 11/1983
 EP 225 155 A2 6/1987
 EP 225155 A2 6/1987
 EP 346518 A1 12/1989
 EP 0505054 * 3/1992
 EP 0 502 391 A2 9/1992
 EP 0 505054 A1 9/1992
 EP 0521642 A1 1/1993
 EP 0 551 788 A1 7/1993
 EP 0666222 A1 2/1994
 EP 0 739 703 10/1996
 EP 0 609 348 B1 2/1997
 EP 0916406 A2 5/1999
 EP 0957030 A2 11/1999
 EP 1 063 076 A1 12/2000
 FR 1571499 6/1969
 FR 2607109 5/1988
 GB 781103 8/1957
 GB 1113988 5/1968
 GB 2050919 A 1/1981
 GB 2372977 A 9/2002
 JP 48-31050 9/1973
 JP 49-28628 7/1974
 JP 54-72181 A 6/1979
 JP S54-70185 6/1979
 JP 56-56830 A 5/1981
 JP 356056830 A 5/1981
 JP S56-62911 5/1981
 JP 56-72730 U 6/1981
 JP 57-210829 A 1/1982
 JP S57-17730 1/1982
 JP 57-37827 2/1982
 JP 57-37827 U 2/1982
 JP 57-126310 8/1982
 JP 58-055005 4/1983
 JP 61-192539 A 8/1986
 JP 63-189224 A 8/1988
 JP 64-004662 2/1989
 JP 3-43342 2/1991
 JP 3-43342 A 2/1991
 JP 03-076625 4/1991
 JP 4-10012 1/1992
 JP 5-193694 8/1993
 JP 53-10239 A 11/1993
 JP 06270235 A 9/1994
 JP 6-336238 A 12/1994
 JP 07-300121 A 11/1995
 JP H08-048322 2/1996
 JP 08-244747 A 9/1996
 JP 8-253220 A 10/1996
 JP 8-282633 A 10/1996
 JP 2009-001639 A 1/1997

JP 09-039934 A 2/1997
 JP 9-110045 A 4/1997
 JP 09039934 A 10/1997
 JP 10-167226 A 6/1998
 JP 10-181734 A 7/1998
 JP 10-230919 A 9/1998
 JP 3056271 11/1998
 JP 11-218537 A 8/1999
 JP 2000-229615 A 8/2000
 JP 2002-127237 A 5/2002
 JP 2002-160717 A 6/2002
 JP 2002-2160717 A 6/2002
 JP 2002-326618 A 11/2002
 JP 2003-095238 4/2003
 JP 2004-026307 A 1/2004
 JP 2006-501109 1/2006
 JP 2007-216981 A 8/2007
 JP 2008-189721 A 8/2008
 NZ 240448 6/1995
 NZ 296014 10/1998
 NZ 335565 10/1999
 NZ 506684 9/2001
 NZ 512423 9/2001
 NZ 521694 10/2003
 WO 93/09031 A1 5/1993
 WO 93/12975 A1 7/1993
 WO 94/05555 3/1994
 WO 94/06617 3/1994
 WO 97/03885 2/1997
 WO 97/14617 4/1997
 WO 97/34808 9/1997
 WO 97/34808 A1 9/1997
 WO 99/21770 5/1999
 WO 00/38902 A1 7/2000
 WO 00/51895 A1 9/2000
 WO 01/12531 A1 2/2001
 WO 01/40081 A1 6/2001
 WO 01/74689 A1 10/2001
 WO 02/02418 A1 1/2002
 WO 02/18213 A1 3/2002
 WO 02/085755 10/2002
 WO 2004/028910 A1 4/2004
 WO 2004/106175 A1 12/2004
 WO 2004/106176 A2 12/2004
 WO 2005/012091 A2 2/2005
 WO 2005/025999 A1 3/2005
 WO 2005/087628 A1 9/2005
 WO 2006/113428 A3 10/2006
 WO 2007/047574 A1 4/2007
 WO 2007/127337 A2 11/2007
 WO 2010/058098 A2 5/2010

OTHER PUBLICATIONS

Final Office Action for U.S. Appl. No. 10/558,284 dated Sep. 9, 2008.
 Office Action for U.S. Appl. No. 10/558,284 dated Jan. 25, 2008.
 Office Action for U.S. Appl. No. 10/851,083 dated Nov. 28, 2008.
 Final Office Action for U.S. Appl. No. 10/851,083 dated Jun. 12, 2008.
 Office Action for U.S. Appl. No. 10/851,083 dated Sep. 6, 2007.
 International Search Report for PCT/US2005/008374 dated Aug. 2, 2005.
 IPRP (including Written Opinion) for PCT/US2005/008374 dated Sep. 13, 2006.
 International Search Report for PCT/US2004/016405 dated Feb. 15, 2005.
 IPRP (including Written Opinion) for PCT/US2004/016405 dated Nov. 25, 2005.
 Office Action for Application No. EP 06 750 165.0-2307 dated Nov. 24, 2008.
 International Search Report for PCT/US2006/040361 dated Feb. 26, 2007.
 IPRP (including Written Opinion) for PCT/US2006/040361 dated Apr. 16, 2008.
 International Search Report for PCT/US2007/006318 dated Sep. 11, 2007.

(56)

References Cited

OTHER PUBLICATIONS

- IPRP (including Written Opinion) PCT/US2007/006318 dated Sep. 16, 2008.
- IPRP (including Written Opinion) PCT/US2006/014055 dated Oct. 16, 2007.
- International Search Report for PCT/US2004/024581 dated Jul. 25, 2005.
- IPRP (including Written Opinion) for PCT/US2004/024581 dated Jan. 30, 2006.
- Official Notification for counterpart Japanese Application No. 2006-522084 dated May 19, 2009.
- Examination Report for counterpart New Zealand Application No. 545528 dated Jul. 1, 2008.
- Examination Report for counterpart New Zealand Application No. 569422 dated Jul. 1, 2008.
- Examination Report for New Zealand Application No. 550336 dated Mar. 26, 2009.
- Examination Report for counterpart New Zealand Application No. 545528 dated Sep. 20, 2007.
- Examination Report for counterpart New Zealand Application No. 569422 dated Sep. 29, 2009.
- Office Action for U.S. Appl. No. 11/249,342 dated Jun. 10, 2009.
- Office Action for U.S. Appl. No. 11/249,342 dated Jan. 12, 2010.
- Office Action for Chinese Application No. 2006800380748 dated Jul. 10, 2009.
- Examiner's Report for Australian Application No. 2006236674 dated Sep. 18, 2009.
- Examiner's Report for Australian Application No. 2006236674 dated Nov. 6, 2009.
- Office Action for Chinese Application No. 200680012360.7 dated Jul. 10, 2009.
- Examination Report for New Zealand Application No. 563134 dated Aug. 3, 2009.
- Office Action for U.S. Appl. No. 11/375,040 dated Dec. 1, 2009.
- Office Action for European Application No. 07752979.0-2307 dated Aug. 21, 2009.
- Final Office Action for U.S. Appl. No. 10/566,294 dated Sep. 10, 2009.
- Office Action for U.S. Appl. No. 10/566,294 dated Apr. 21, 2009.
- Final Office Action for U.S. Appl. No. 10/566,294 dated Feb. 13, 2009.
- Office Action for U.S. Appl. No. 10/566,294 dated Oct. 27, 2008.
- "Application and Development of PET Plastic Bottle," Publication of Tsinghad Tongfang Optical Disc Co. Ltd., Issue 4, 2000, p. 41. (No English language translation available).
- International Search Report for PCT/US2006/014055 dated Dec. 7, 2006.
- International Search Report and Written Opinion dated Mar. 15, 2010 for PCT/US2010/020045.
- International Search Report and Written Opinion dated Sep. 8, 2009 for PCT/US2009/051023.
- Chanda, M. & Roy, Salil K., *Plastics Technology Handbook*, 2007, CRC Press, pp. 2-24-2-37.
- Office Action dated Feb. 3, 2010 for Canadian Application No. 2,604,231.
- Communication dated Mar. 9, 2010 for European Application No. 09 173 607.4 enclosing European search report and European search opinion dated Feb. 25, 2010.
- Office Action dated Oct. 26, 2010, U.S. Appl. No. 11/362,416.
- Final Office Action dated May 7, 2010, U.S. Appl. No. 11/362,416.
- Office Action dated Oct. 2, 2009, U.S. Appl. No. 11/362,416.
- Office Action dated Feb. 2, 2011, U.S. Appl. No. 11/399,430.
- Office Action dated Aug. 5, 2010, U.S. Appl. No. 11/399,430.
- Final Office Action dated Feb. 22, 2010, U.S. Appl. No. 11/399,430.
- Office Action dated Sep. 4, 2009, U.S. Appl. No. 11/399,430.
- Office Action dated Jun. 19, 2009, U.S. Appl. No. 11/399,430.
- European Search Report for EPA 10185697.9 dated Mar. 21, 2011.
- Final Office Action for U.S. Appl. No. 11/362,416 dated Apr. 29, 2011.
- Office Action, Japanese Application No. 2008-506738 dated Aug. 23, 2011.
- Extended European Search Report for EPA 10185697.9 dated Jul. 6, 2011.
- Final Office Action dated Jan. 14, 2011, U.S. Appl. No. 11/704,368.
- Office Action dated Jul. 8, 2010, U.S. Appl. No. 11/704,368.
- Office Action dated Jun. 18, 2009, U.S. Appl. No. 11/362,416.
- Patent Abstracts of Japan, vol. 012, No. 464; Dec. 6, 1988.
- Patent Abstracts of Japan, vol. 2002, No. 09, Sep. 4, 2002.
- Patent Abstracts of Japan, vol. 015, No. 239, Jun. 20, 1991.
- Office Action dated Aug. 14, 2012, in Japanese Patent Application No. 2008-535769.
- Final Rejection dated Sep. 14, 2012, in U.S. Appl. No. 12/964,127.
- Nonfinal Office Action dated Sep. 24, 2012, in U.S. Appl. No. 12/184,368.
- Office Action dated Sep. 21, 2010, U.S. Appl. No. 11/249,342.
- Office Action dated Jan. 12, 2010, in U.S. Appl. No. 11/249,342.
- Examiner's Report dated Feb. 15, 2011 in Application No. AU200630483.
- Office Action dated Oct. 31, 2011, in Australian Patent Application No. 2011203263.
- Office Action dated Jul. 19, 2011, in Japanese Patent Application No. 2008-535769.
- Office Action dated Dec. 6, 2011, in Japanese Patent Application No. 2008-535769.
- International Search Report and Written Opinion for PCT/US2012/050251 dated Nov. 16, 2012.
- Final Rejection dated Nov. 14, 2012, in U.S. Appl. No. 12/916,528.
- U.S. Appl. No. 13/210,350, filed Aug. 15, 2011, Wurster et al.
- U.S. Appl. No. 13/251,966, filed Oct. 3, 2011, Howell et al.
- U.S. Appl. 13/210,358, filed Aug. 15, 2011, Wurster et al.
- U.S. Appl. No. 13/410,902, filed Mar. 2, 2012, Gill.
- International Search Report and Written Opinion for PCT/US2012/050256 dated Dec. 6, 2012.
- Requisition dated Feb. 3, 2010 for Canadian Application No. 2,604,231.
- Requisition dated Jan. 9, 2013 for Canadian Application No. 2,559,319.
- Office Action dated Feb. 5, 2013, in Mexican Patent Application No. Mx/a/2008/004703.
- Office Action dated Jul. 26, 2010 for Canadian Application No. 2,527,001.
- Australian Office Action dated Mar. 3, 2011 in Application No. 2010246525.
- Australian Office Action dated Nov. 8, 2011, in Application No. 2011205106.
- Examiner Report dated May 26, 2010, in Australian Application No. 2004261654.
- Examiner Report dated Jul. 23, 2010, in Australian Application No. 2004261654.
- Requisition dated May 25, 2010 for Canadian Application No. 2,534,266.
- Communication dated Jun. 16, 2006, for European Application No. 04779595.0.
- Final Official Notification dated Mar. 23, 2010 for Japanese Application No. 2006-522084.
- International Search Report and Written Opinion dated Dec. 18, 2012, in PCT/US12/056330.
- Trial Decision dated Mar. 26, 2013 in Japanese Patent Application No. 2008-535759.
- Office Action dated Dec. 20, 2011, U.S. Appl. No. 12/856,516.
- Office Action dated Feb. 6, 2012, U.S. Appl. No. 12/856,484.
- Final Office Action dated May 21, 2012, U.S. Appl. No. 12/856,516.
- Final Office Action dated Jun. 15, 2012, U.S. Appl. No. 12/856,484.
- Notice of Allowance dated Aug. 4, 2011, U.S. Appl. No. 11/362,416.
- Office Action dated Oct. 14, 2011, U.S. Appl. No. 12/697,309.
- Notice of Allowance dated Apr. 5, 2012, U.S. Appl. No. 12/697,309.
- Notice of Allowance dated Aug. 2, 2012, U.S. Appl. No. 12/856,484.
- Taiwanese Office Action dated Jun. 10, 2012, in Application No. 095113450.

(56)

References Cited

OTHER PUBLICATIONS

Japanese First Notice of Reasons for Rejection dated Aug. 23, 2011, in Application No. 2008-506738.

Japanese Second Notice of Reasons for Rejection dated Jun. 11, 2012, in Application No. 2008-506738.

Office Action dated Oct. 12, 2012, in U.S. Appl. No. 12/856,516.

U.S. Appl. No. 13/251,966, Sep. 19, 2014 Notice of Allowance.

U.S. Appl. No. 12/856,516, Oct. 3, 2014 Non-Final Office Action.

U.S. Appl. No. 12/856,516, Jun. 30, 2016 Non-Final Office Action.

U.S. Appl. No. 12/856,516, Dec. 16, 2015 Appeal Brief Filed.

U.S. Appl. No. 12/856,516, Oct. 19, 2015 Notice of Appeal Filed.

U.S. Appl. No. 12/856,516, Aug. 18, 2015 Response after Final Action.

U.S. Appl. No. 12/856,516, Jun. 18, 2015 Final Office Action.

U.S. Appl. No. 12/856,516, Jan. 5, 2015 Applicant Initiated Interview Summary.

U.S. Appl. No. 12/856,516, Jan. 5, 2015 Response to Non-Final Office Action.

U.S. Appl. No. 13/251,966, Nov. 19, 2014 Issue Fee Payment.

* cited by examiner

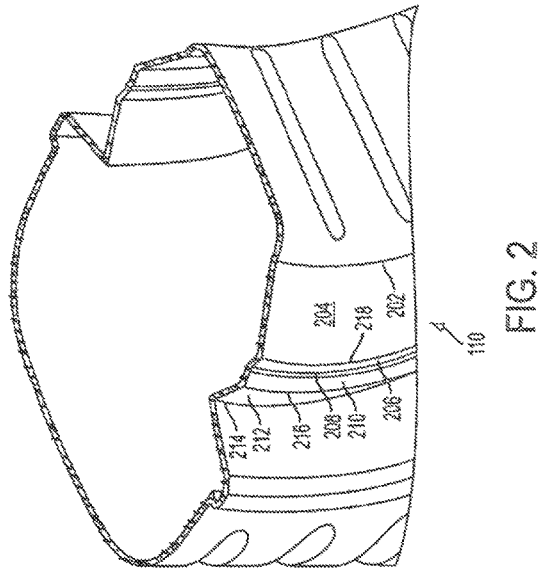
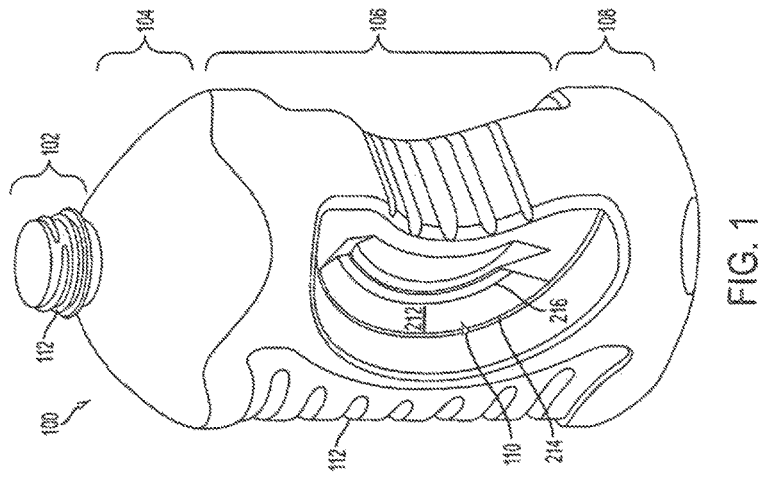

FIG. 2

FIG. 1

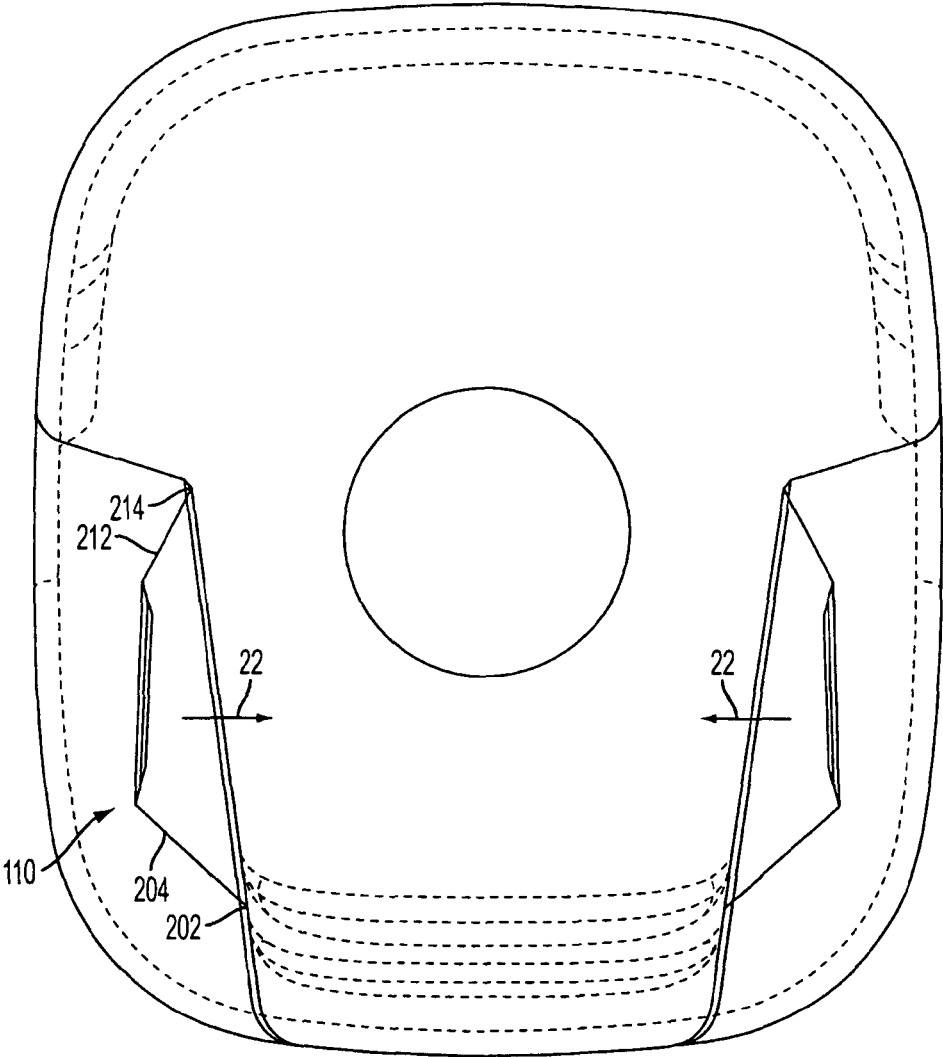

FIG. 3A

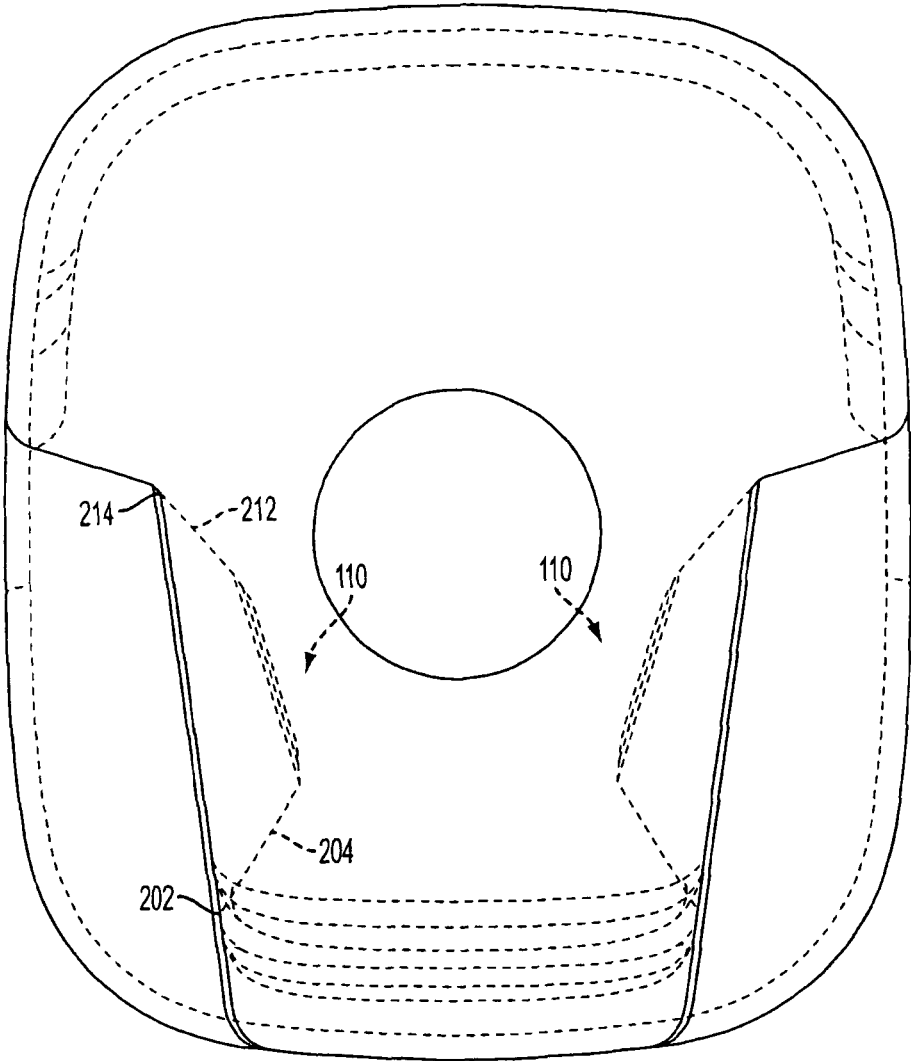

FIG. 3B

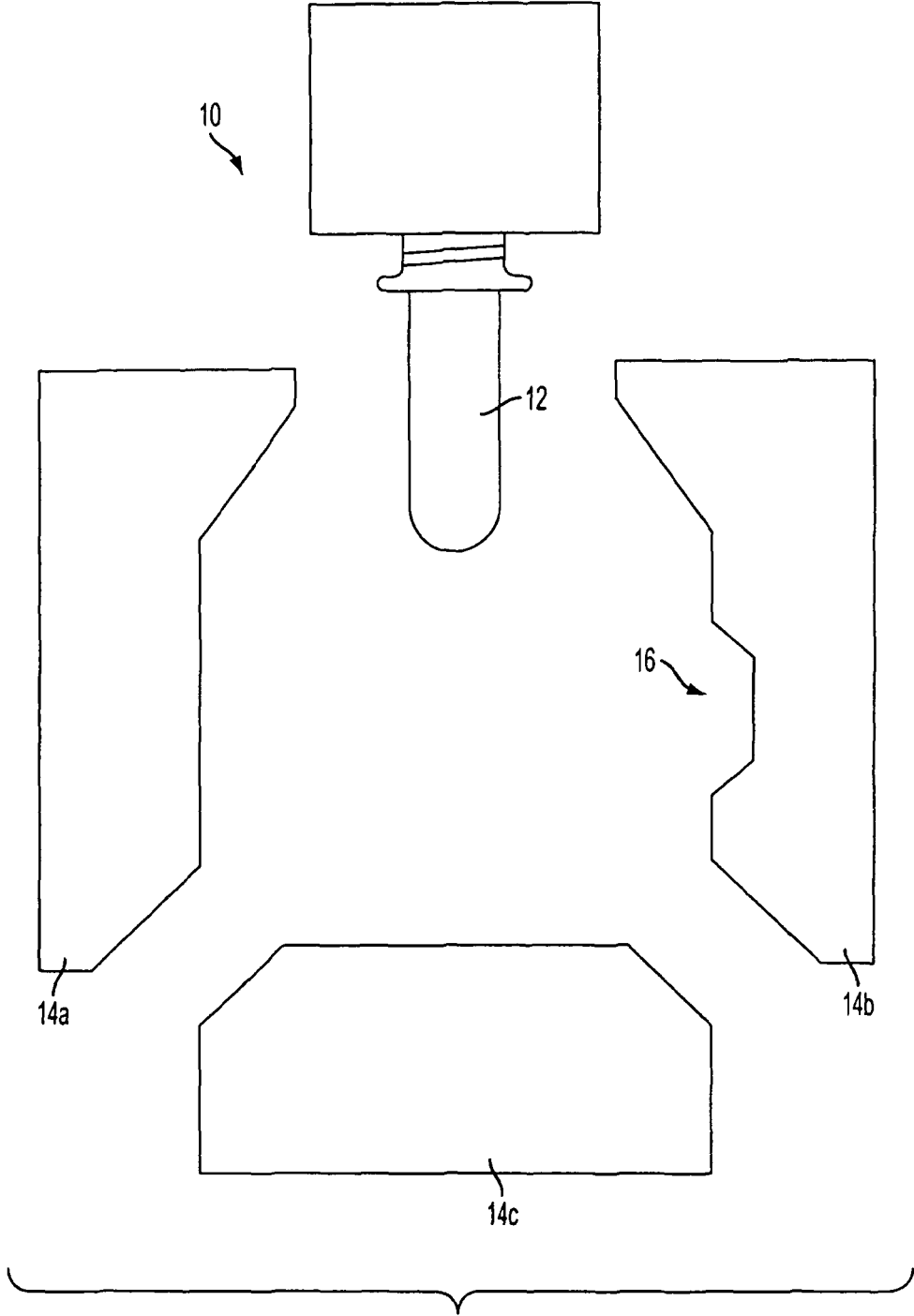

FIG. 4

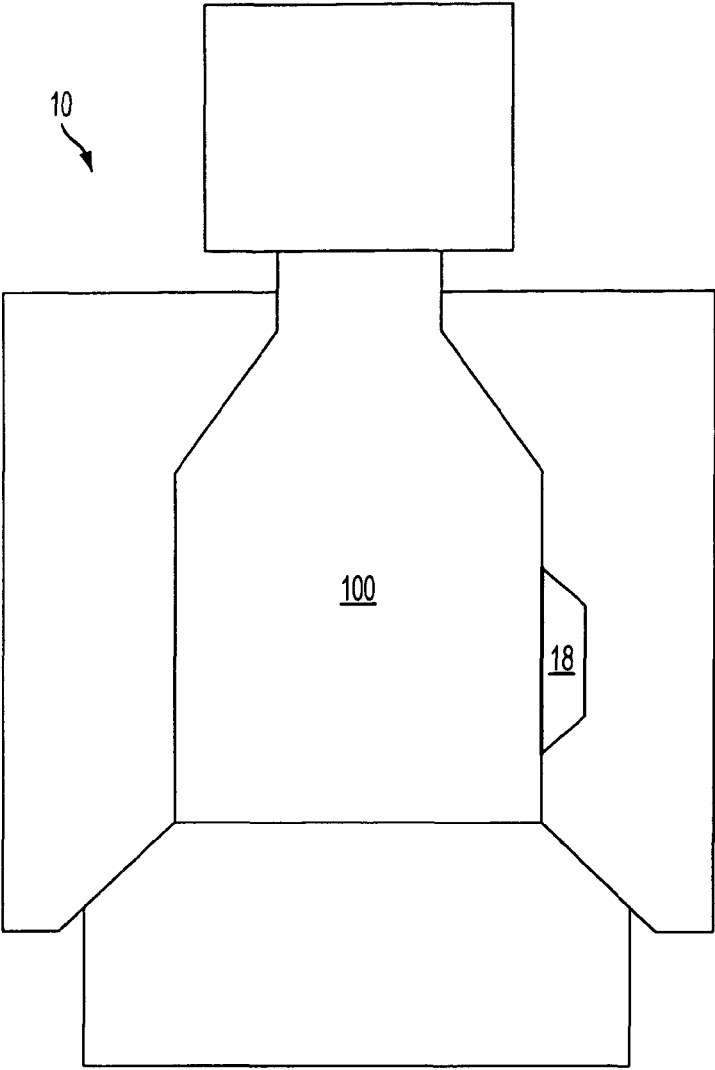

FIG. 5

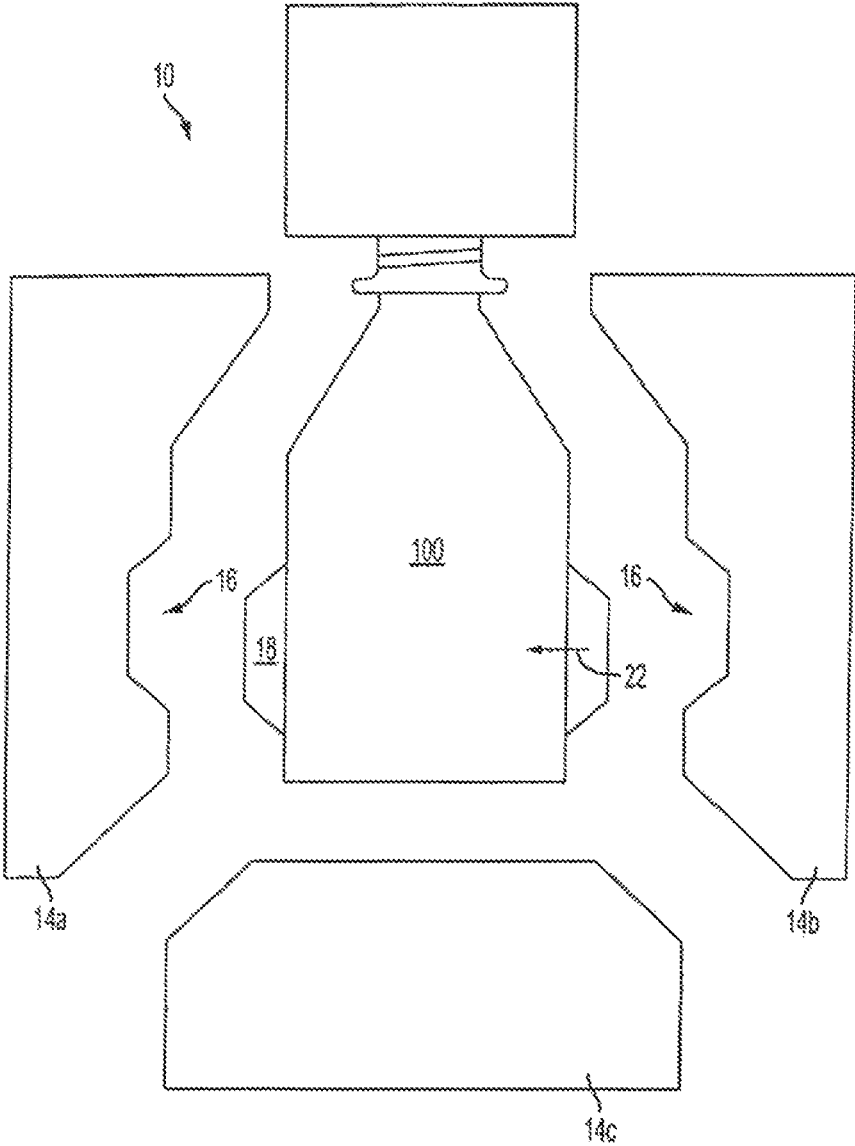
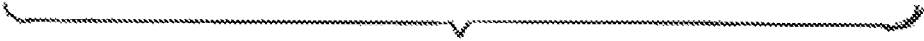

FIG. 6



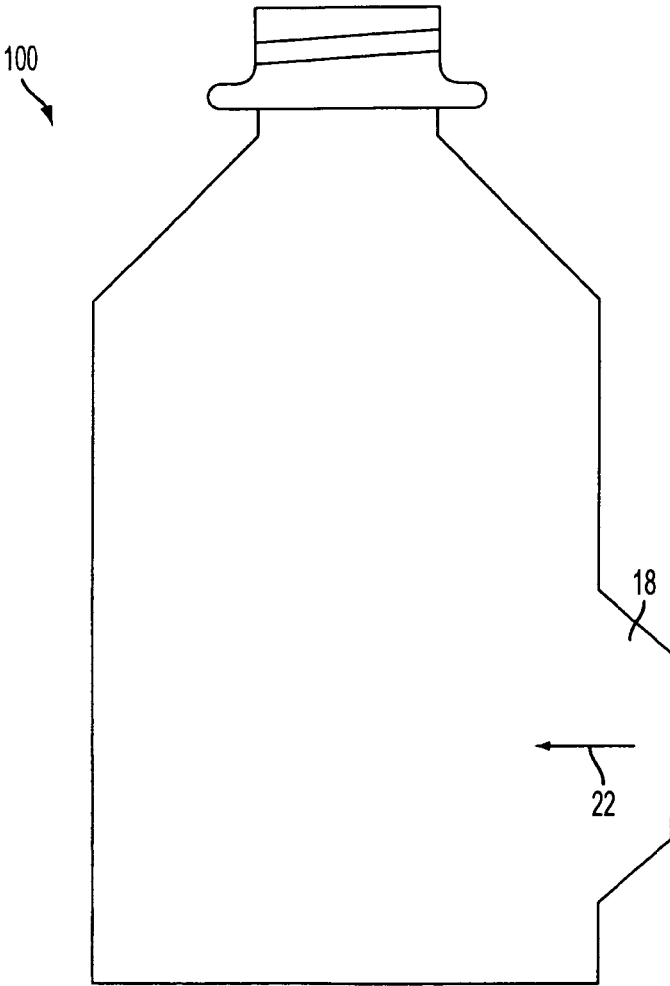

FIG. 7A

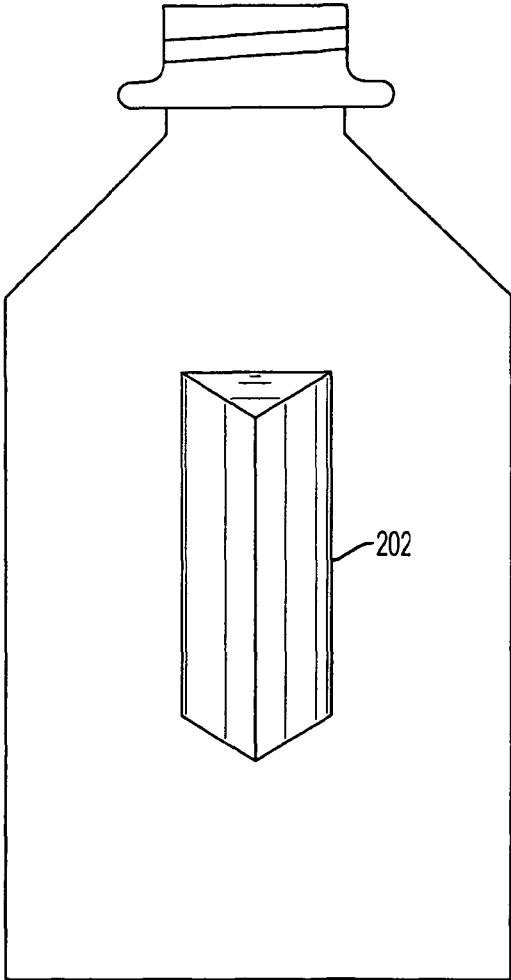

FIG. 7B

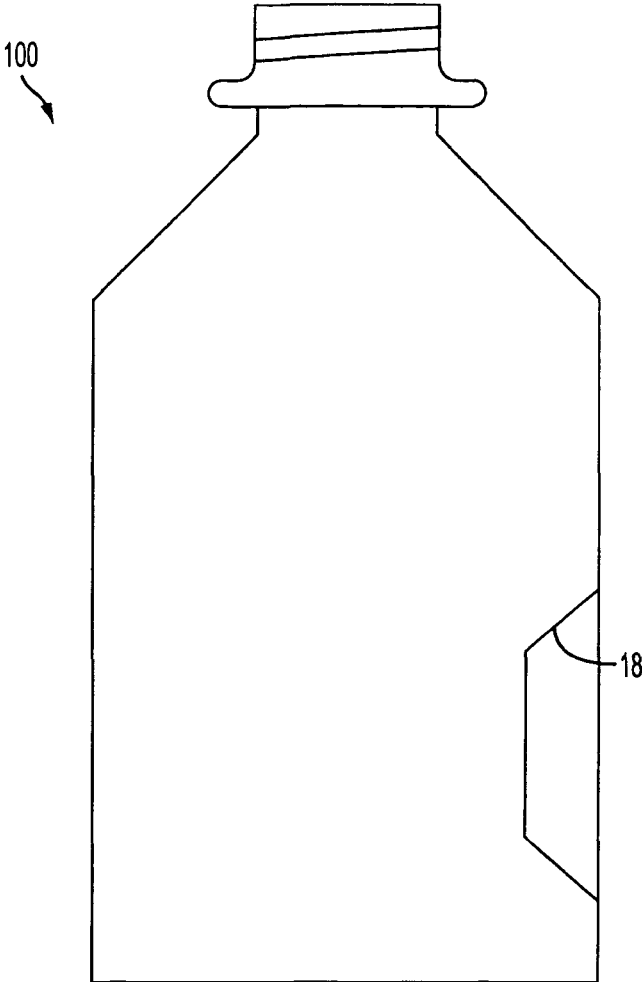

FIG. 7C

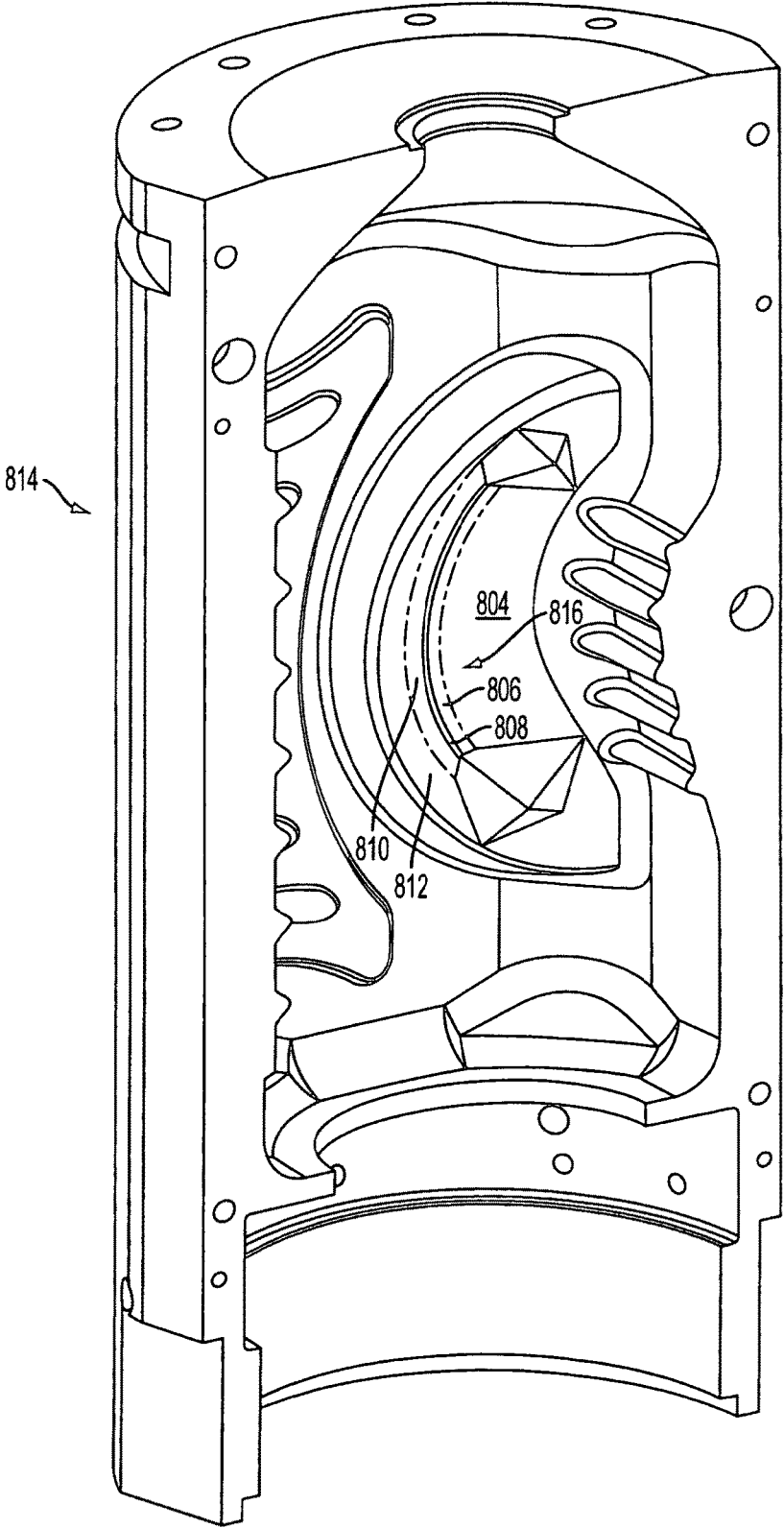

FIG. 8

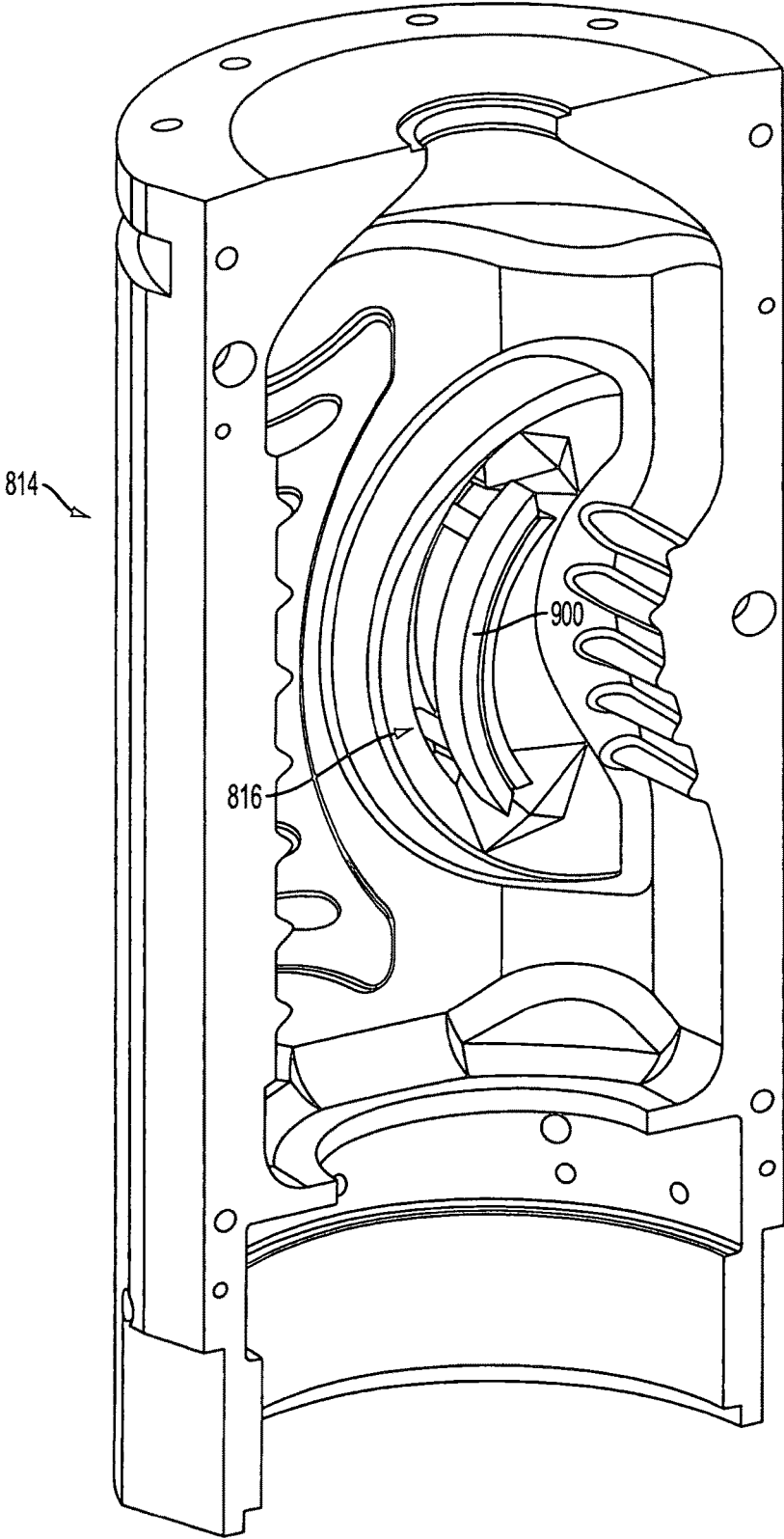

FIG. 9

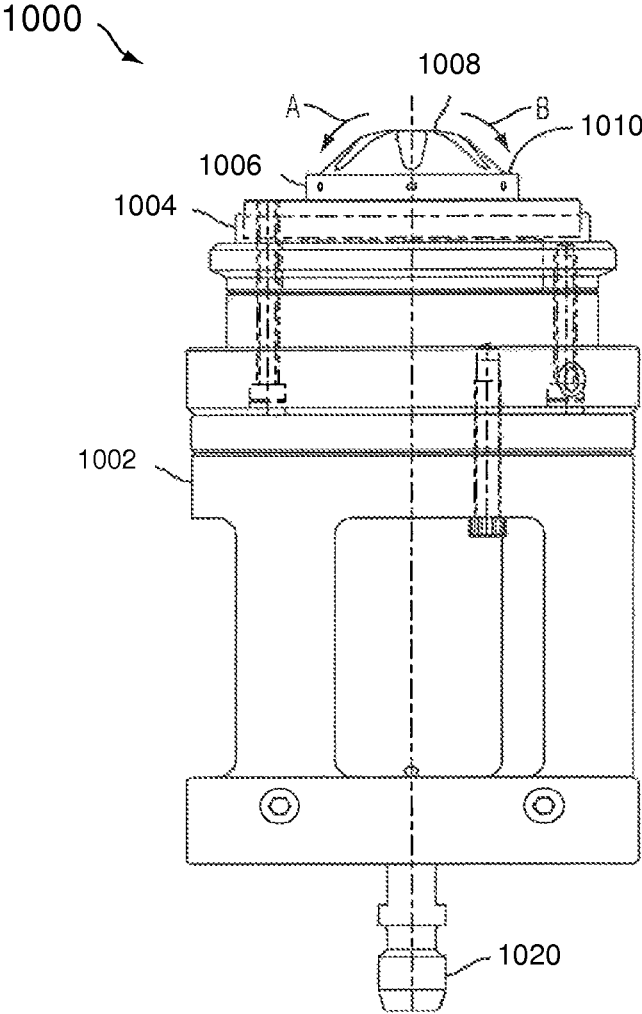

FIG. 10
PRIOR ART

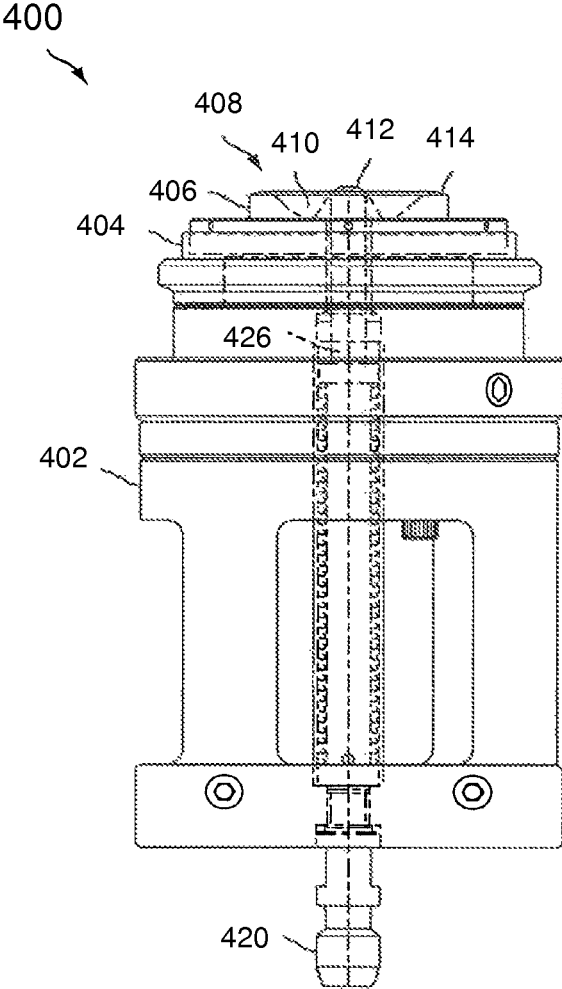

FIG. 11A

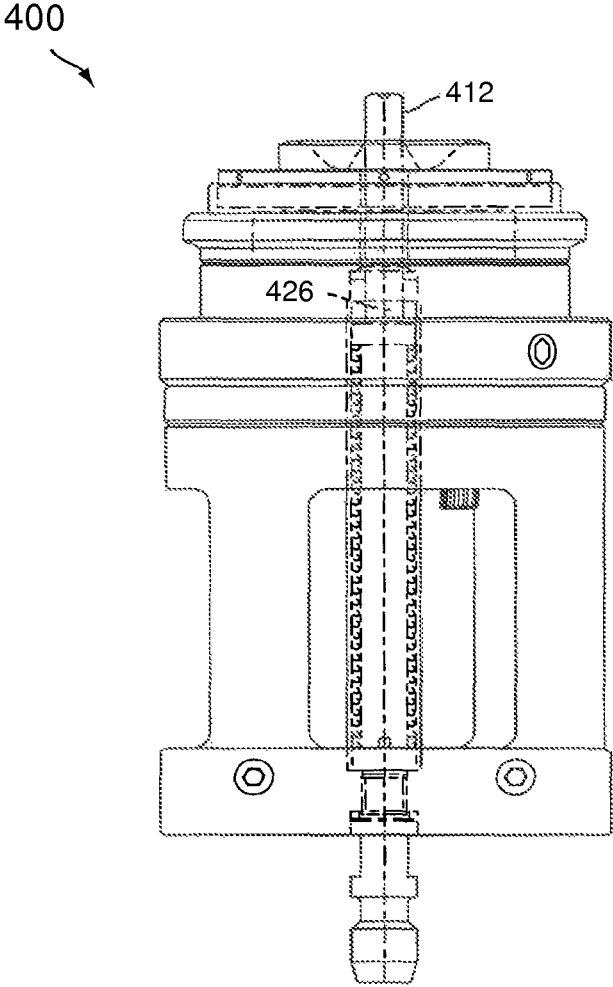

FIG. 11B

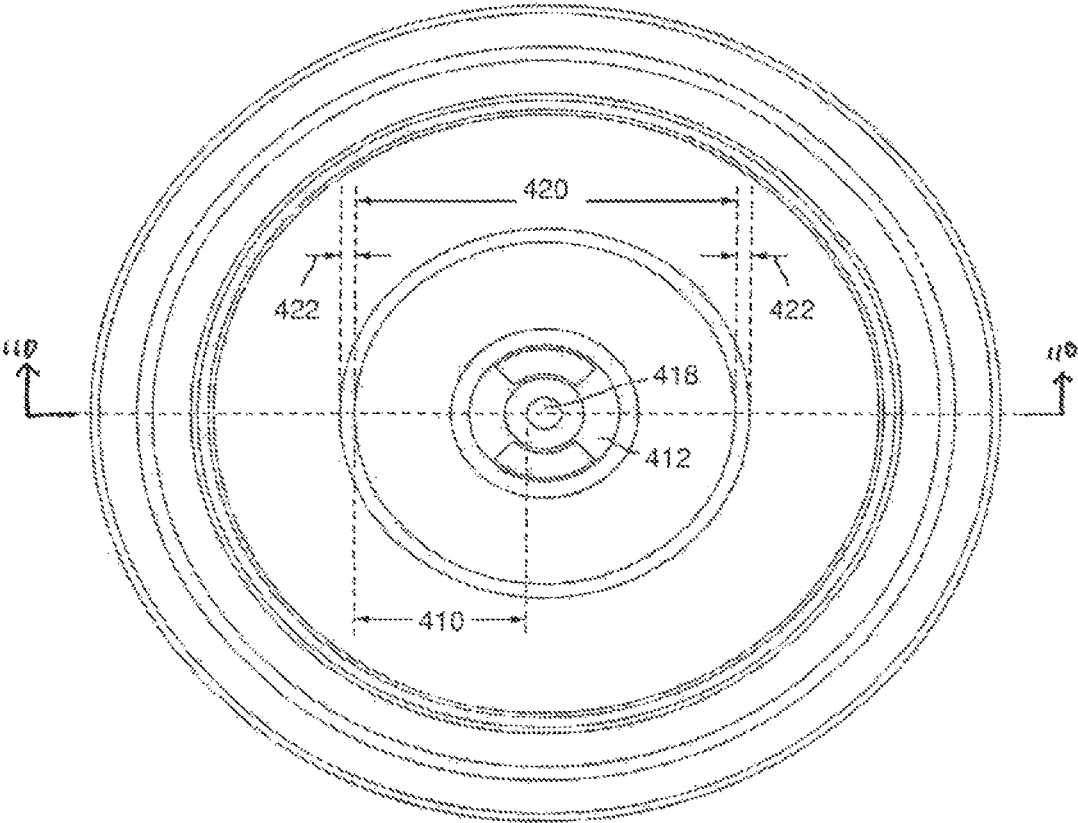

FIG. 11C

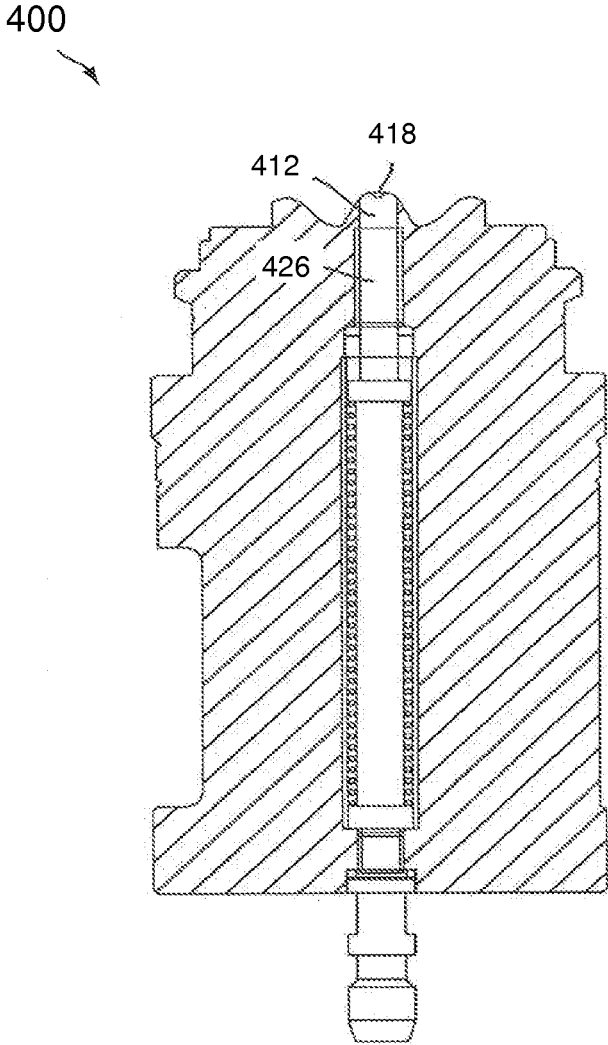

FIG. 11D

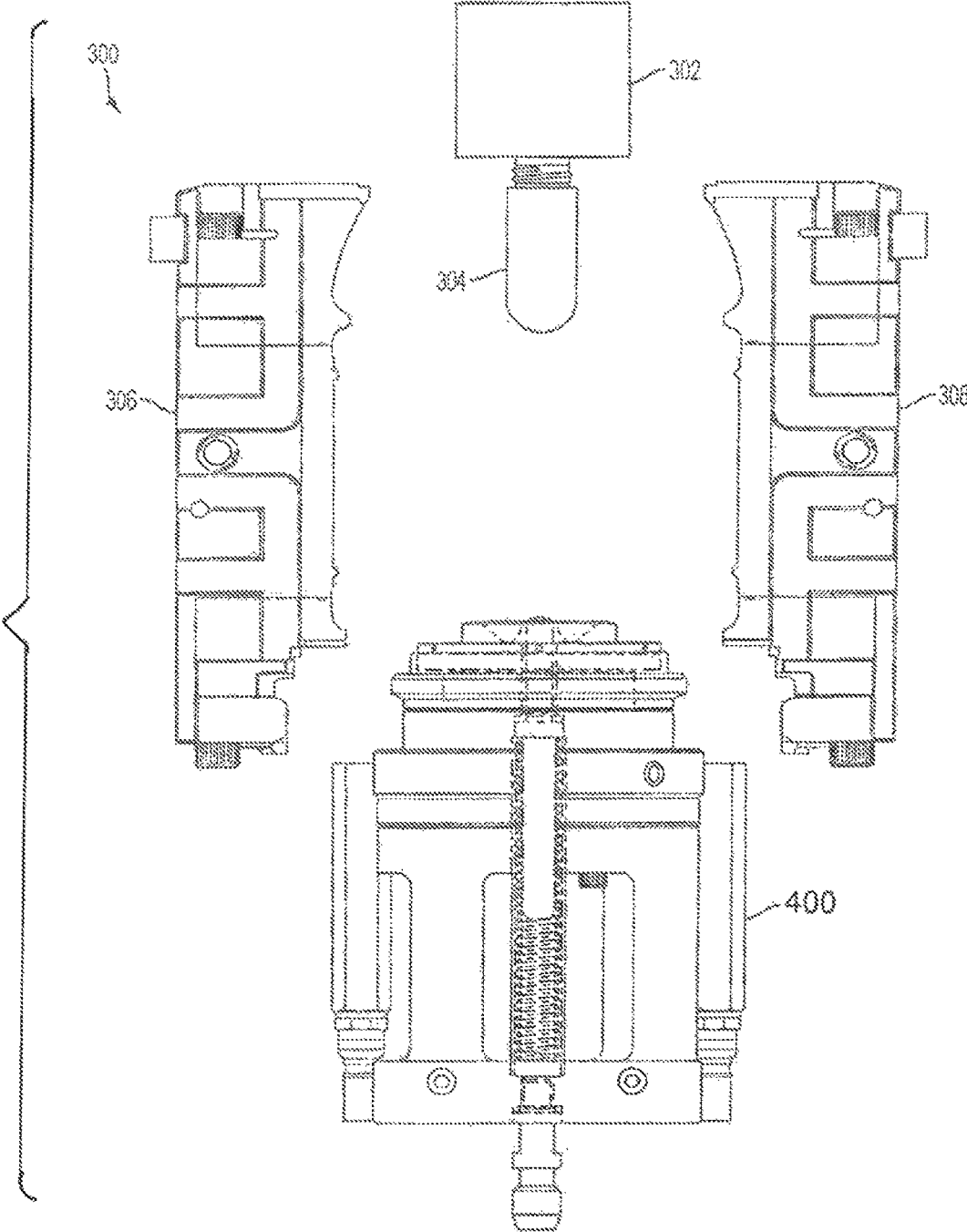

FIG. 12A

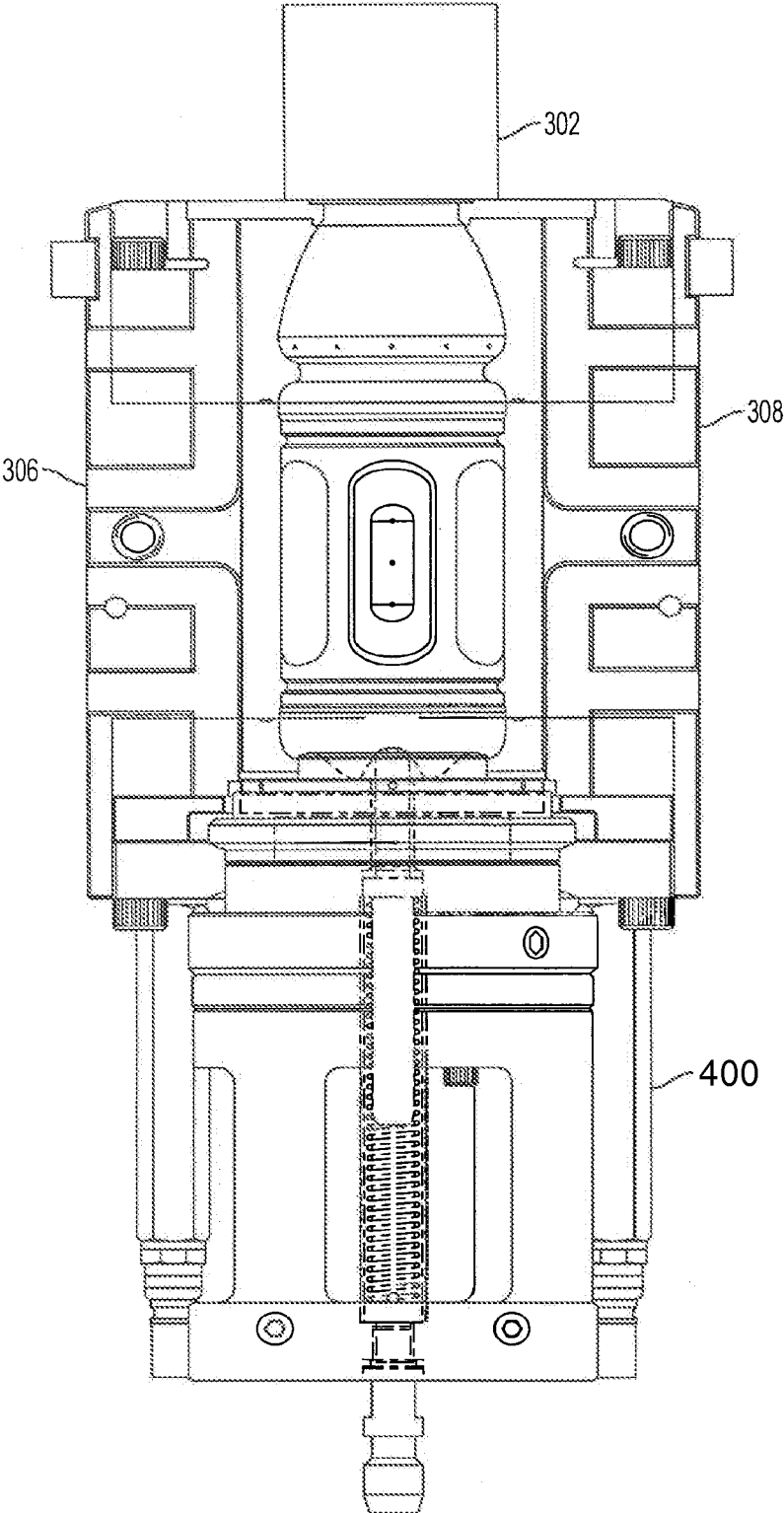

FIG. 12B

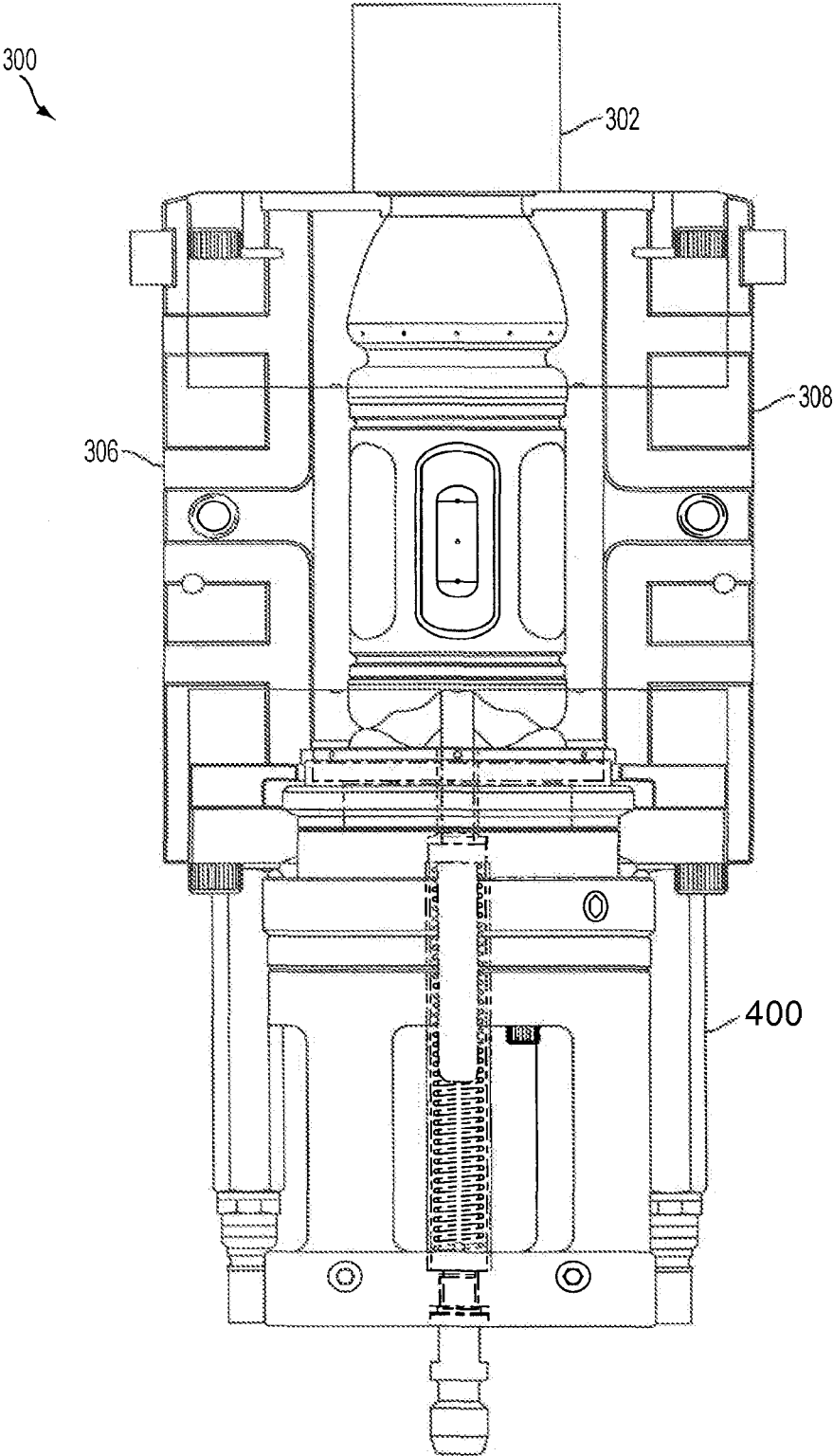

FIG. 13A

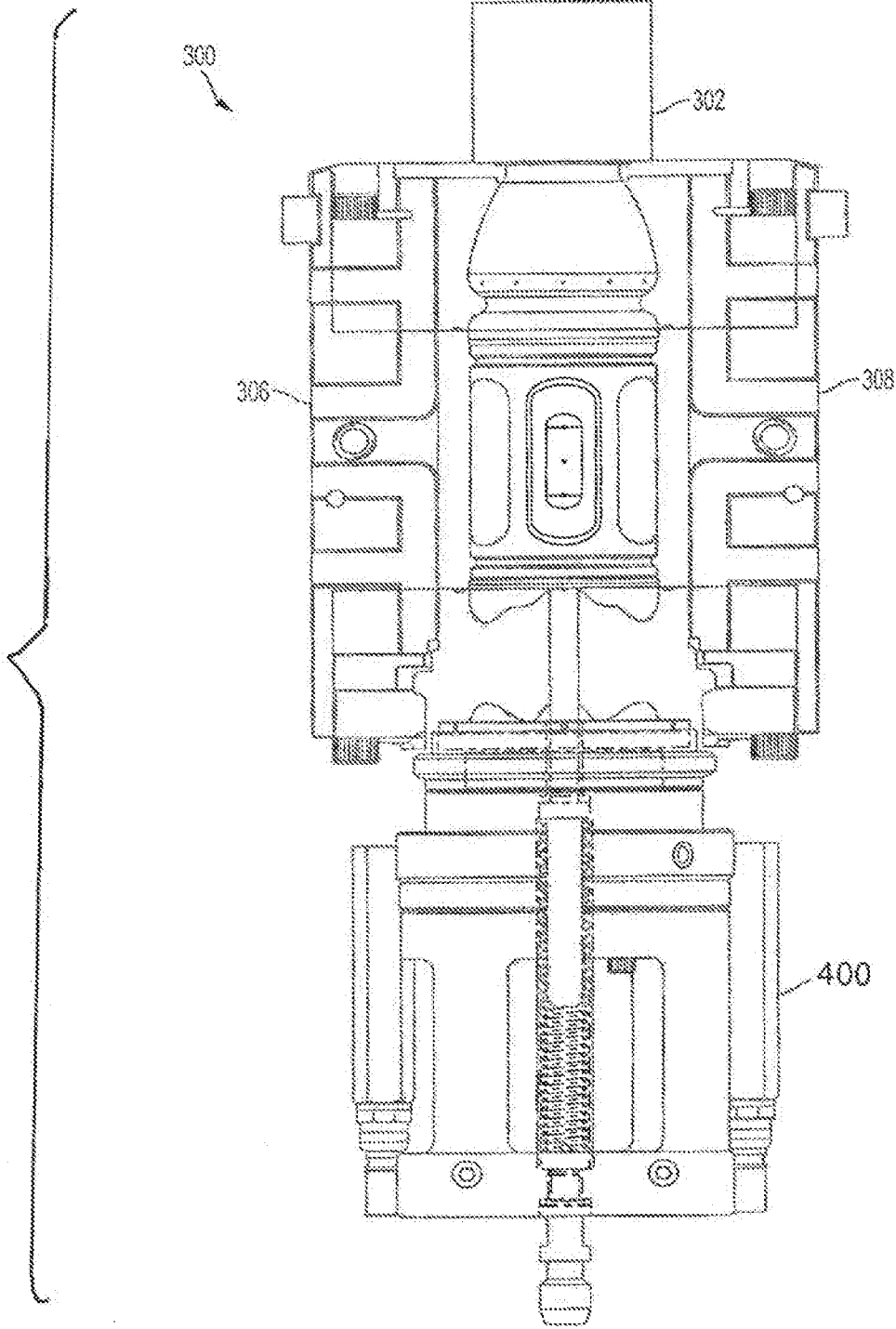

FIG. 13B

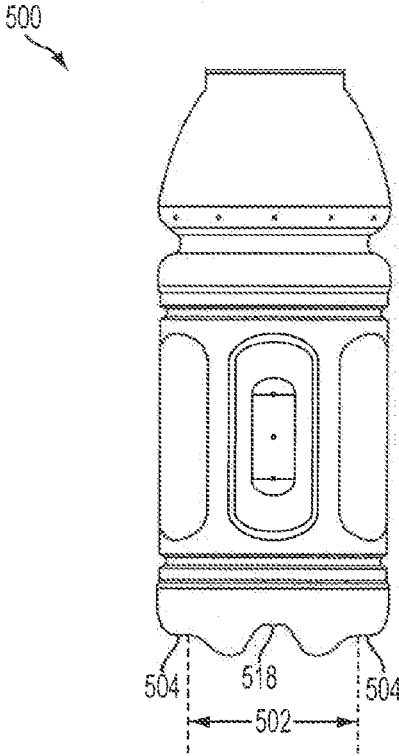

FIG. 14A

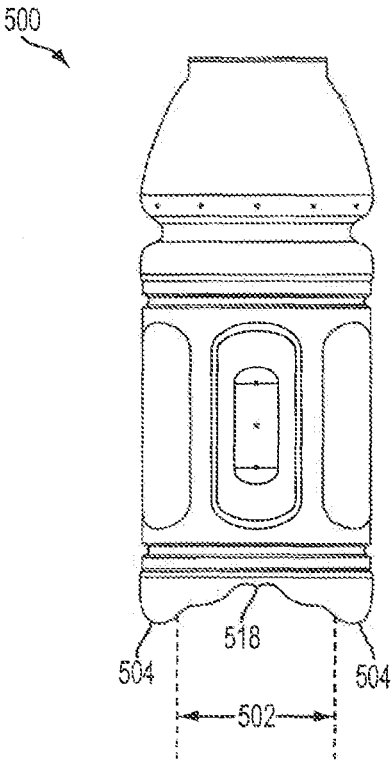

FIG. 14B

CONTAINER HAVING OUTWARDLY BLOWN, INVERTIBLE DEEP-SET GRIPS

CROSS-REFERENCE TO RELATED APPLICATIONS

This application is a continuation-in-part (CIP) of application Ser. No. 12/627,922 filed Nov. 30, 2009, which is a division of application Ser. No. 11/399,430 filed Apr. 7, 2006 (now U.S. Pat. No. 8,017,065), the subject matter of each of the foregoing applications is hereby incorporated by reference in its entirety.

The invention generally relates to a method for blow molding a container, and more particularly to a method for blow molding a container to be formed with deep-set grips so that the formed container has secure grippability along with a good ergonomic feel. The present invention also relates generally to forming a blow molded container, and more particularly to a method for forming a blow molded container that increases orientation of material at a region of the blow molded container.

One method of manufacturing containers is through a process known as stretch blow molding. In this process, a preformed parison, or preform, is prepared from a thermoplastic material, typically by an injection molding process. The preform typically includes a threaded end, which becomes the threads of the container. During stretch blow molding, the preform is positioned between two open blow mold halves. The blow mold halves close about the preform and cooperate to provide a cavity into which the preform is blown to form the container. Once the mold is closed, a gas is forced into the preform causing it to stretch and to take the shape of the mold as the plastic contacts the mold. After molding, the mold halves open to release the blow molded container.

One problem with stretch blow molding is that stretching of the plastic material may affect the performance of the container at certain areas. While the stretching of the plastic material may not cause problems for most sections of the container, it particularly affects the ability of the plastic material to form around a deep protrusion in the mold. In some applications of container manufacturing, a deep protrusion may be required to form a particular section of a container. For example, the particular sections of the container formed by an inset or deep protrusion may include the dome, sidewalls, and the base of the container. As the plastic contacts the deep protrusion of the mold, the plastic must stretch and flow around the protrusion into a recess. However, the plastic material is less able to flow and stretch around the protrusion because, of the contact friction with the mold surface. Insufficient material distribution at a region, such as at the base, may affect the ability of the region to maintain its shape around the protrusion during hot filling, the strength of the region, or the ability of the container to stand on a flat surface.

A lack of definition in the base caused by the inability of the plastic to properly form at a deep protrusion is a particular problem. While this is a particular problem in the base region, similar problems exist in other regions of a container where an inset is positioned. As stated previously, these other regions formed with an inset or deep protrusion can include the dome, the sidewalls, etc. of a container. These problems can exist with any forming process, such as blow molding (e.g., extrusion or injection), where material must flow around a protrusion of a mold to form an inset region of a container. This is particularly true for blow

molding processes including stretch blow molding, extrusion blow molding and injection blow molding.

Some containers have deep-set grips on either side of the bottle so that a consumer can easily pick up the filled container with a firm grasp of his/her hand. When blowing deep-set grips with known blow molding processes, plastic material becomes trapped in the grip regions consequently starving other regions of the container of material. To account for this, the container weight is increased as more material is required to be used to ensure that a sufficient amount of material is provided for all parts of the container. Alternatively, design compromises are made so that the resultant thinner regions are closer to the axis of the container causing those regions to be blown with more material. However, blowing heavier-containers and the resultant design constraints do not solve the problem described above.

One or more embodiments of the invention include formation of a container with a deep-set protrusion (e.g., in the base and/or as a grip) that overcomes the shortcomings of conventional solutions that introduce additional costs, molding time, and complexity into the mold setup.

Furthermore, a container may be manufactured through a process known as blow molding. In blow molding, a parison is received at a blow molding apparatus, and the parison is enclosed by a container mold. The blow molding apparatus inflates the parison by forcing gas into the parison which causes the parison to stretch and take the shape of the container mold. Once the parison has taken the shape of the container mold, the blow molding step is complete and the container is removed from the container mold for further processing.

In some applications of container manufacturing, a deep protrusion may be required at a particular section of a container, most often at a base or at a hand grip of the container. Deep protrusions, when located at the base of the container, are sometimes referred to as "push-ups" since the protrusions push up into the interior of the container. However, employing known techniques to manufacture containers with deep protrusions has various problems. One such problem is the orientation of the plastic material around the deep protrusion. Orientation refers to how closely the molecules in a plastic material are packed together. Orientation of plastic molecules occurs as the plastic material stretches, and the greater the material stretch, the higher the orientation. As the orientation of the plastic molecules increases, the molecules straighten and may form a crystalline structure. Typically, the higher the crystallinity of the plastic, the greater the rigidity of the plastic, which improves the structural integrity of the container. The structural integrity of the container may be important during hot fill processing as the container must be able to withstand the rigors of hot fill processing.

In a hot fill process, a product is added to the container at an elevated temperature, about 82° C., which can be near the glass transition temperature of the plastic material, and the container is capped. During hot fill processing and in the subsequent cooling, the container base may experience roll out, distortion, or deformation that can cause the container to lean or become unstable. This problem can be reduced or eliminated by increasing orientation of material in the container base.

During blow molding of a container, gas is forced into a parison which causes the parison to inflate and stretch to take the shape of the container mold. However, the parison cools as it contacts the container mold. Cooling of the parison affects its ability to stretch, and thus its ability to orient. While this may not cause problems for most sections of the

3

container, it particularly affects the orientation of the material formed around a deep protrusion. As the parison contacts the deep protrusion, the parison must flow around the protrusion into a recess. As the parison contacts the protrusion and cools, the parison is less able to flow around the protrusion, which affects the ability of the parison to stretch and to orient plastic material at the recess. Insufficient orientation at a region, such as at a base or at a hand grip, may affect the ability of the region to maintain its shape around the protrusion, the strength of the region, or the ability of the container to stand on a flat surface. Cooling of the parison also is known to create thick amorphous plastic sections around the protrusion, which adds excess plastic material to the container and affects the rigidity around the protrusion. The thick amorphous plastic sections add to the weight of the container, and thus the cost.

A known system for manufacturing a blow molded container is described in U.S. Pat. No. 5,255,889 to Collette et al., which is incorporated herein by reference. In the system described therein, a preform is received and enclosed by a mold chamber, which includes two side movable mold members and a base mold. In the mold chamber, the base mold member has an upper base plug with a protrusion that extends upward toward the center of the mold chamber. During blow molding, gas is forced into the preform to inflate and stretch the preform material into the shape of the mold chamber. As the preform material reaches the protrusion, the material stretches around the protrusion into a recess to form a bearing surface of the container. Once the container is formed, the mold chamber (the two side mold members and the base mold member) opens and releases the molded container. However, the base of the containers generated by this system may have limited crystallinity, a build up of amorphous unoriented material, or other problems in the base similar to those described above due to forcing the preform to stretch around the protrusion into the recess to form the bearing surface of the container.

Likewise, FIG. 10 illustrates a base assembly **1000** for forming a container base according to the prior art. The base assembly **1000** includes a base pedestal **1002**, a centering pin **1020**, and a base plug **1004**, with the base plug **1004** being secured to a top surface of the base pedestal **1002**. The centering pin **1020** may be used to secure and position the base assembly in a blow molding apparatus (not shown). The base plug **1004** includes a base mold **1006** for forming a container base. The base mold **1006** includes a protrusion **1008** for forming a deep protrusion in the container base, and a surface **1010** for forming a bearing surface of the container base.

During blow molding of a parison into a container, the base mold **1006** forms the parison material into a base of the container. As the parison material contacts the base mold **1006**, the parison material stretches around the protrusion **1008** down to the surface **1010** for forming the bearing surface, as indicated by the arrows A and B. However, once the parison contacts the protrusion **1008**, the parison material begins to cool and the orientation of the parison material is slowed, which causes the formation of thick amorphous plastic sections in the base. The thick amorphous plastic sections affect the rigidity of the base, the ability of the container to stand on a flat surface, and add to the cost of the container.

What is needed is an improved system for forming a deep protrusion in a container that overcomes the shortcomings of conventional solutions.

BRIEF SUMMARY

One aspect of the invention is to create a deep-set grip in a container that provides secure grippability along with a

4

good ergonomic feel in the resultant container. In a preferred embodiment, the deep-set grip is achieved in a manner to maintain the overall container weight at an as minimal a weight as possible, and to allow for a wide range of design applications.

The invention includes a container forming assembly including a mold having a sidewall with a recess, and a method for making the container.

A method according to exemplary embodiments of the invention includes receiving a parison, enclosing the parison within a mold having a wall with a recess, inflating the parison into the mold to form a blow molded container where the blow molded container has a sidewall, a movable region formed at the recess that extends outward from the container, and a hinge circumscribing an interface between the sidewall and the movable region, and moving the movable region about the hinge before filling the blow molded container with liquid or other consumable product.

A container forming assembly according to an exemplary embodiment of the invention forms a container from a parison where the container has at least one movable gripping region. The container forming assembly includes a mold adapted to form a first portion and a second portion of the at least one movable gripping region wherein the first portion is rotatable about a first hinge toward an interior of the container, the first hinge being formed at a first seam between the first portion and the container, and said second portion is rotatable about a second hinge toward the interior of the container, the second hinge being formed at a second seam between the second portion and the container; and a drive mechanism adapted to move the mold to enclose the parison during blow molding and to release the container after blow molding.

Another exemplary method according to the invention is directed to a method for increasing crystallinity of a blow molded container. This exemplary method includes inflating a parison in a mold having a wall with a recess to form a blow molded container having a movable gripping region, the movable gripping region being formed at the recess, the blow molded container having a hinge coupled to said movable gripping region, the hinge circumscribing an interface between the blow molded container and the movable gripping region; and moving the movable gripping region about said hinge toward an interior of said blow molded container before filling the blow molded container.

The container forming assembly according to another exemplary embodiment would include a first mold half forming a first movable gripping region and a second mold half forming a second movable gripping region where the second movable gripping region has hinges, rotatable portions and the structure of the first movable gripping region.

In the exemplary embodiment, each of the first and second mold halves have a recess forming a movable gripping portion forming region that includes a first surface adapted to form a first outer grip portion of the movable gripping region, a second surface adapted to form a second outer grip portion of the movable gripping region, a third surface adapted to form a first inner grip portion of the movable gripping region, a fourth surface adapted to form a second inner grip portion of the movable grip portion; and a fifth surface area adapted to form a ridge area of the movable gripping portion.

The container forming assembly of the foregoing exemplary embodiment may further have its fifth surface area positioned between the third and fourth surfaces, and wherein the third and fourth surfaces positioned adjacent to the first and second surfaces, respectively.

5

The invention also includes a method for forming a container, a method for increasing crystallinity of a container, a base assembly for forming a container, and a container.

The method of the invention for forming a container includes receiving a parison, enclosing the parison with a mold having a cavity, inflating the parison in the mold to form a blow molded container with a moveable region at the cavity, and repositioning the moveable region before filling said blow molded container.

The method of the invention for increasing crystallinity of a container includes inflating a parison to form a blow molded container having a moveable region, at least a portion of the moveable region protruding outward from the blow molded container, and repositioning the moveable region before filling the blow molded container.

The base assembly of the invention, which is adapted to form a container with a base having a moveable region and having a bearing surface, includes a base pedestal, a push rod coupled to the base pedestal, and a base plug coupled to the base pedestal. The base plug has a base mold adapted to form the moveable region and to form the bearing surface of the base so that at least a portion of the moveable region protrudes outward from the base beyond the bearing surface. The push rod is adapted to reposition the moveable region before filling the container.

The container of the invention includes a base having a moveable region with a dimple, and a bearing surface that is offset from the moveable region. After blow molding and before filling the container, at least a portion of the moveable region protrudes outward beyond the bearing surface.

Further advantages, as well as the structure and function of exemplary embodiments will become apparent from a consideration of the description, drawings, and examples.

One or more embodiments of the invention can include a method for providing a plastic bottle with a deep-set grip in a sidewall of the bottle by injection blow molding, the method comprising: enclosing a parison within a multi-piece mold, the multi-piece mold having a first distinct portion thereof that includes a first wall with a first recess; performing injection blow molding to the parison in the mold to form an injection blow molded plastic bottle, the injection blow molded plastic bottle having a sidewall, a first movable region being formed in the sidewall in correspondence with the first recess of the first wall so that the first movable region extends into the first recess such that corresponding material of the plastic bottle substantially entirely covers a surface area of the first recess, a first hinge circumscribing a first interface between the sidewall and the first movable region, a wall thickness at the first hinge being thinner than immediately surrounding portions of the injection blow molded plastic bottle on both sides of the first hinge; and moving the first movable region toward an interior of the blow molded plastic bottle about the first hinge, said moving occurring before filling the injection blow molded plastic bottle with a product. The first distinct portion of the multi-piece mold is not a deep-set mold with a projection, and after said moving the first movable region toward the interior of the container, the first moveable region is deep-set to form the deep-set grip. Optionally, the deep-set grip is a deep-set handle.

Further, the first movable region, after said moving thereof, can extend inwardly from the first interface more than it extended outwardly into the first recess. For instance, the inward depth of the grip may be at or about 25 mm inward from the interface, or greater than 25 mm. Put

6

another way, the inward depth of the grip may be at or about 1 inch or greater than 1 inch.

Optionally, the deep-set grip is arranged in an upper third portion of the sidewall. Further, the movement of the movable region toward the interior is performed in a one-step process. In one or more embodiments, the bottle is a wide-mouth bottle.

In one or more embodiments, the sidewall of the plastic bottle further includes a second deep-set grip, wherein the multi-piece mold can have a second distinct portion thereof that includes a second wall with a second recess, wherein said performing injection blow molding to the parison in the mold to form an injection blow molded plastic bottle forms a second movable region in the sidewall in correspondence with the second recess of the second wall so that the second movable region extends into the second recess such that corresponding material of the plastic bottle substantially entirely covers a surface area of the second recess, a second hinge circumscribing a second interface between the sidewall and the second movable region, a wall thickness at the second hinge being thinner than immediately surrounding portions of the injection blow molded plastic bottle on both sides of the second hinge; and moving the second movable region toward an interior of the blow molded plastic bottle about the second hinge, said moving occurring before filling the injection blow molded plastic bottle with a product, wherein the second distinct portion of the multi-piece mold is not a deep-set mold with a projection, and after said moving the second movable region toward the interior of the container, the second moveable region is deep-set to form the second deep-set grip.

Optionally, the second deep-set grip is arranged in an upper third portion of the sidewall. Further, optionally, said moving the first movable region is in a first direction, and said moving the second movable region is in a second direction, the first direction being opposite to the second direction. The first deep-set grip and the second deep-set grip may be arranged centrally about the sidewall in a longitudinal or height direction of the plastic bottle. That is, in one or more embodiments, the first and second deep-set grip may be symmetrical in configuration and positioning with respect to the sidewall.

In one or more embodiments of the invention, the performing injection blow molding to the parison in the mold can form one or more vacuum panels, each of the one or more vacuum panels being distinct from first movable region. The product to be filled into the plastic bottle may be one of a dry product and a wet product, the wet product including one of applesauce, water, non-carbonated beverages, and oil.

Optionally, the first movable region can have a plurality of surfaces, and said moving the first movable region causes the surfaces to fold in relation to one another such that the first movable region is inverted to form the deep-set grip.

In one or more embodiments, the method may also comprise transporting the container to a location remote from the location at which said performing injection blow molding is performed; filling the formed, plastic bottle with a product; and sealing the filled plastic bottle.

One or more embodiments of the invention can include a method for making a blow molded plastic container with at least one deep-set grip, the method comprising: providing a plastic preform; positioning the preform with respect to a container forming apparatus, the container forming apparatus having at least one recess, the number of said at least one recesses corresponding to the number of at least one deep-set grips; inflating the preform to form a plastic container in

an intermediate configuration with at least one projection extending outwardly therefrom in correspondence with the number of said at least one recesses of the container forming apparatus; and repositioning each said at least one projection inwardly into an inner volume of the intermediate container configuration to form a final container configuration.

Optionally, the at least one projection and corresponding deep-set grip may be at a first portion of the sidewall of the container, and a second portion of the sidewall of the container is without any deep-set grips. Further, the at least one deep-set grip may include at least two of said deep-set grips, the at least two deep-set grips being on opposite sides of the container so as to form a deep-set handle. Optionally, the two deep-set grips can extend inward such that they almost touch each other. Alternatively, the two deep-set grips may extend inward such that they touch each other.

One or more embodiments of the invention can include an injection stretch blow molded plastic bottle comprising: a threaded neck portion defining an opening into the plastic bottle; a body portion having a sidewall and a plurality of deep-set grips, each said deep-set grip being defined by an interface with the sidewall, a wall thickness at the interface being thinner than immediately surrounding portions of the sidewall on both sides of the interface; and a base portion defining a standing surface of the plastic bottle. Optionally, the bottle is a wide-mouth bottle.

Further, the plurality of deep-set grips may form one deep-set handle. Optionally, the inward depth of each said deep-set grips may be greater than 25 mm inward from the corresponding interface.

Optionally, each said deep-set grip may be arranged in an upper third portion of the sidewall. Optionally or alternatively, each said deep-set grip is arranged in an upper quarter of the bottle. Optionally, each said deep-set grip is arranged only in an upper third or upper quarter of the plastic bottle.

In one or more embodiments, said plurality of deep-set grips can include a first deep-set grip on a first side of the bottle and a second deep-set grip on a second side of the bottle, the first deep-set grip being a mirror image of the second deep-set grip. Optionally, said plurality of deep-set grips can include a first deep-set grip on a first side of the bottle and a second deep-set grip on a second side of the bottle, the first deep-set grip being identical in configuration. In one or more embodiments, more than two deep-set grips or deeply set portions may be implemented. Further, optionally or alternatively, said plurality of deep-set grips can include a first deep-set grip on a first side of the bottle and a second deep-set grip on a second side of the bottle, and the sidewall further including smooth portions separating the first and second deep-set grips. Optionally, said plurality of deep-set grips includes a first deep-set grip and a second deep-set grip, the first deep-set grip and the second deep-set grip being arranged centrally about the sidewall in a longitudinal or height direction of the plastic bottle.

For one or more embodiments of the invention, each said deep-set grip may be with or without any ribs, braces, vacuum panels, design, and/or ridges. Further, in one or more embodiments, the bottle may be in the form of an hour-glass in side view. Additionally, optionally, the body portion and/or the base portion may include one or more vacuum panels, each of said one or more vacuum panels being distinct from each said deep-set grip.

In one or more embodiments of the invention, a finally formed plastic container can comprise: a neck portion defining an opening into the finally formed plastic container; a body portion having a sidewall and one or more deeply recessed portions, each said deeply recessed portion; and a

base portion defining a standing support for the finally formed plastic container to stand in an upright position. Optionally, a shoulder or dome portion may be between the body portion and the neck portion.

Optionally, each of said one or more deeply recessed portions are arranged only in an upper half of the finally formed container and no deeply recessed portions are arranged in a lower half of the finally formed container. Optionally, each of said one or more deeply recessed portions are arranged only in an upper third of the finally formed container. Optionally, each of said one or more deeply recessed portions are arranged only in an upper quarter of the finally formed container.

In one or more embodiments, at least one of said one or more deeply recessed portions can have a length greater than a width thereof, with the length running in a direction perpendicular to a longitudinal axis of the finally formed container. Alternatively, the length may run parallel to the longitudinal axis. Optionally, said one or more deeply recessed portions includes a first deeply recessed portion and a second deeply recessed portion, the first and second deeply recessed portions having overlapping and touching portions thereof.

BRIEF DESCRIPTION OF THE DRAWINGS

The foregoing and other features and advantages of the invention will be apparent from the following, more particular description of exemplary embodiments of the invention, as illustrated in the accompanying drawings, wherein like reference numbers may generally indicate identical, functionally similar, and/or structurally similar elements.

FIG. 1 depicts an exemplary embodiment of a first stage of a container with the deep-set grip inverted, according to the present invention;

FIG. 2 depicts a cross sectional view of the exemplary container of FIG. 1 according to the present invention;

FIG. 3A depicts an exemplary embodiment of a grip of a container according to the present disclosure prior to inversion of the grip.

FIG. 3B depicts an exemplary embodiment of a grip of a container according to the present disclosure subsequent to inversion of the grip.

FIG. 4 illustrates a parison received before a mold according to an exemplary embodiment of the invention;

FIG. 5 schematically illustrates an exemplary blow molded container with a movable region according to the invention;

FIG. 6 schematically illustrates another exemplary blow molded container with a movable region being inverted prior to release from the mold on each side of the container;

FIG. 7A is a schematic illustration of inversion of the moveable region of the exemplary container after release from the mold and prior to inversion of the moveable region.

FIG. 7B is a schematic illustration in perspective view of the moveable region of the exemplary container after release from the mold and prior to inversion of the moveable region.

FIG. 7C is a schematic illustration of a first step of inversion of the moveable region of the exemplary container after inversion of the moveable region.

FIG. 8 illustrates a mold for forming half of the container shown in FIG. 1; and

FIG. 9 shows an embodiment of the mold that can be activated to push in an outwardly protruding region toward the center of the container.

FIG. 10 illustrates a base assembly for forming a container base according to the prior art.

FIG. 11A is a schematic illustration of an exemplary embodiment of a base assembly according to the present disclosure.

FIG. 11B is a schematic illustration of an exemplary embodiment of a base assembly according to the present disclosure with rod end extended.

FIG. 11C is schematic illustration in top view of an exemplary embodiment of a base assembly according to the present disclosure.

FIG. 11D is a schematic illustration in cross sectional view of an exemplary embodiment of a base assembly according to the present disclosure along line 11D of FIG. 11C, with base pedestal 402 shown in cross section.

FIG. 12A is a schematic illustration of an exemplary embodiment of a base assembly in use prior to inflation of a parison during container molding according to the present disclosure.

FIG. 12B is a schematic illustration of an exemplary embodiment of a base assembly in after inflation of a parison during container molding according to the present disclosure.

FIG. 13A is a schematic illustration of an exemplary embodiment of base repositioning by a push rod according to the present disclosure.

FIG. 13B is a schematic illustration of an alternative exemplary embodiment of base repositioning by a push rod to the present disclosure with rod end extended.

FIG. 14A depicts an exemplary embodiment of a container according to the present disclosure prior to repositioning of the base.

FIG. 14B depicts an exemplary embodiment of a container according to the present disclosure after repositioning of the base.

Further objectives and advantages, as well as the structure and function of exemplary embodiments will become apparent from a consideration of the description, drawings, and examples.

DETAILED DESCRIPTION

Exemplary embodiments of the invention are discussed below. In describing the exemplary embodiments, specific terminology is employed for the sake of clarity. However, the invention is not intended to be limited to the specific terminology so selected. While specific exemplary embodiments are discussed, it should be understood that this is done for illustration purposes only. A person skilled in the relevant art will recognize that other components and configurations may be used without parting from the spirit and scope of the invention. All references cited herein are incorporated by reference as if each had been individually incorporated.

Exemplary embodiments of the present invention may generally relate to a container, a method of inverting a grip of a container, and a blow molding apparatus for forming a container having an invertible grip. The grip can be a deep-set grip. In an exemplary embodiment, as shown in FIG. 4, a blow-molding apparatus 10 may receive a parison 12 and enclose the parison with a mold 14a-c, which may include a recess 16 in the outer surface of the mold 14b. The blow-molding apparatus 10 may inflate the parison into the mold to form a blow molded container 100 (see FIG. 5). The blow molded container 100 may have a sidewall, a movable region 18 formed at the recess 16, and a hinge circumscribing an interface between the sidewall of container 100 and the movable region 18. The blow-molding apparatus may be adapted to move the movable region 18 about the hinge before filling the blow molded container 100. An internal

volume of the blow molded container may be reduced by moving the movable region 18 into the center of the container 100 (arrow 22 in FIGS. 6 and 7A) as schematically shown in FIG. 7C. The movable region 18 may form a grip for the container 100. By blow molding the movable region 18 or grip in its outward position (outside the container) and then inverting the movable region to form the grip by using a simple mechanical force, the weight of the container may be reduced and the definition of the grip may be improved.

FIG. 1 illustrates an exemplary embodiment of a container representing the shape of the container as stretch blow molded according to the present invention, FIG. 2 illustrates an exemplary embodiment of a movable region of a container in its outwardly blown position according to the present invention, and FIGS. 3A-B illustrate an exemplary embodiment of the movable region of a container in its outwardly blown position and the final configuration of the grip according to the present invention, respectively.

The exemplary embodiments will initially be discussed with reference to FIGS. 1-2. According to an exemplary embodiment of the present invention, container 100 is blow molded into the shape as schematically illustrated in FIG. 7. FIG. 1 illustrates a perspective side view of the exemplary container 100 according to an exemplary embodiment of the present invention. As depicted, the container 100 includes an upper portion 102, a shoulder 104, a container body 106, and a base 108. The upper portion 102 of the container 100 generally is any structure having an opening into the interior of the container 100 and being adapted to receive a closure (not shown). The closure may be any device used to create a substantially air tight seal for a hot-filled product within the container 100, thus substantially preventing air from entering the container 100 through the upper portion 102. In one exemplary embodiment, the upper portion 102 includes threads 112 that are adapted to couple with a closure that is a twist-on cap. The cap may be twisted onto the threads 112 of the upper portion 102 to create a seal with the container 100. In an alternative embodiment, a sealing plug may be placed in the upper portion 102 to seal the container 100. Other closures or seals may be used, as will be appreciated by those of skill in the art.

The shoulder 104 of the container 100 extends from the top of the container body 106 to the bottom of the upper portion 102. Generally, the shoulder 104 narrows as it progresses from the container body 106 to the bottom of the upper portion 102. The shoulder 104 may have any desired shape, or may be omitted from the container 100. The shoulder 104 may include patterns, shapes, and other geometries, or alternatively, may be substantially smooth. In the depicted embodiment, the width of the bottom of the shoulder 104 corresponds to the width of the top of the container body 106, and narrows by curving inward as the shoulder 104 approaches the upper portion 102. The shoulder 104 curves outward before reaching the upper portion 102, and then curves inward as the shoulder 104 reaches the upper portion 102. The shoulder 104 may be other shapes and include other patterns, as will be appreciated by those of skill in the art.

The container body 106 of the container 100 extends from the base 108 to the shoulder 104 and defines an interior of the container 100. The container body 106 is positioned below the shoulder 104. In an alternative embodiment, if the shoulder 104 is omitted from the container 100, the container body 106 extends to the upper portion 102. The container body 106 may be any asymmetrical or symmetrical shape, such as, but not limited to, cylindrical, square, rectangular, or other geometries. Optionally, the container

body **106** of the container **100** may include patterned support structure or vacuum panels. The patterned support structure and the vacuum panels may help provide structural integrity for the container **100**.

In the depicted embodiment, the container body **106** has ribs **112** positioned at various locations on the container **100**. The ribs **112** may be a series of recessed sections alternating with non-recessed sections on the container body **106**. The ribs **112** may include other types and shapes and may also be placed at alternate locations on the container body **106**, as will be appreciated by those of skill in the art. The ribs **112** may also be omitted from the container body **106**, or may be placed at other locations on the container **100**.

The container body **106** may also include a movable region **110** that initially is blow molded outside of the container **100** (see FIG. 6). The movable region **110** is comprised of a number of surfaces in the grip area of the container body **106**. The number of surfaces are arranged in a way so that an external force (arrow **22**) acting on the grip area causes the surfaces to fold in relation to one another until such a point where they snap into an inverted position toward the interior of the container **100**. As depicted in FIG. 2, the movable region **110** may include a first hinge or seam **202**, a first portion **204**, a first inner wall **206**, a second hinge or seam **214**, a second portion **212**, a second inner wall **210**, a third hinge or seam **208**, a fourth hinge or seam **216**, and a fifth hinge or seam **218**. The first hinge or seam **202** couples the first portion **204** so that portion **204** of the container body **106** is initially blow molded outside the container body **106** and then can be pushed inside the container as shown in FIGS. 3A-B, respectively. The second hinge or seam **214** couples the second portion **212** so that second portion **212** can be pushed inside the container **106** by pivoting about second hinge or seam **214**. The fifth hinge or seam **218** couples the first portion **204** with the first inner wall **206**, and the fourth hinge or seam **216** couples the second portion **212** with the second inner wall **210** so that these portions can be pushed inside container **106**. The inverted movable region **110** is shown in FIG. 3B.

The mold of the container forming assembly shown in FIGS. 4-6 may be made of first and second mold halves **14a**, **14b** that each may include a wall with a recess to form respective first and second movable gripping regions **110**. The gripping-regions **110** are initially blown outside the container and then inverted so that a consumer's hand easily fits into the inverted gripping regions.

Initially, when the container **100** is blow molded, the movable region **110** is formed extending away from the interior of the container **100**. FIG. 3A illustrates the movable region **110** as blow molded extending away from the interior of the container **100**, and FIG. 3B illustrates the movable region **110** extending toward the interior of the container **100** after inversion. During inversion, a force may be applied to cause the movable region **110** to invert. As the force is applied, the first portion **204** rotates about the first hinge or seam **202** and the second portion **212** rotates about the second hinge or seam **214**. Additionally, the first portion **204** rotates about the fifth hinge or seam **218** relative to the first inner wall **206**, the second portion **212** rotates about the fourth hinge or seam **216** relative to the second inner wall **210**, and the first inner wall **206** rotates about the third hinge or seam **208** relative to the second inner wall **210**. That is, a many sided movable region **110** is initially blown outside the container thereby avoiding the need for a mold with a deep-set protrusion around which plastic material has difficulty forming the desired thickness about the protrusion. Then, the weights of the plastic at the hinges or seams along

with the angles of the first and second portions and the inner walls are designed so that movable region **110** can be inverted into the container to form a deep-set grip(s) that a consumer can securely grip and that has a good ergonomic feel to the consumer. The container wall thickness at the hinges is thinner than the surrounding portions or inner walls, which are heavier as the plastic naturally moves in this manner. The angles of the first and second portions and the inner walls should be sufficiently steep so that the desired depth of a grip is achieved and the desired ergonomic feel.

During inversion, a sufficient force may be applied to the movable region **110** formed outside the container while the container **100** remains within the mold **14a-c** (see FIG. 5). As the Assignee of the present invention has successfully inverted projections blown outside the base of the container, enough force needs to be applied to the movable region **110** to cause inversion. In one embodiment, the inversion of the moveable region **18** (**110** in FIGS. 1-3B) may occur as late into the blowing process as possible so that the container **100** is allowed to cool as much as possible before the container **100** is released or ejected from the mold. The longer the container and movable region can cool, a better inversion result can be achieved. This is because the warmer the container is during inversion, the higher the probability that the container will crease at an undesired location resulting in an aesthetically displeasing container and thus, a rejected container. The inversion may occur just before the container is ejected or released from the mold to reduce the likelihood that the inversion will form unwanted creases or deformities in the container **100**. An air cylinder (not shown) may be used for the inversion of the movable region **110** by applying a force to the first portion **204** and to second inner wall **210**. Alternatively, other mechanical, pneumatic, hydraulic, or cam operated means for inverting may be used, as will be appreciated by those skilled in the art. For example, the cam operated means may be included within the mold and the movable region may be inverted while the mold fully encloses the formed container.

The container **100** is blow molded into the shape depicted in FIG. 3A to avoid trapping material in recessed areas of a complex shaped mold and to improve the performance (less rejected containers) of the container **100** at the movable region **110** without increasing the amount of material to the region. The movable region **110** is formed into the shape shown in FIG. 3A to ensure that all surfaces of the movable region are properly formed with sufficient amounts of material and have sufficient definition. An advantage of forming the movable region **110** extending away from the interior of the container is that the rigidity at the movable region **110** is increased by allowing for further orientation of plastic material during the blow molding process (see FIGS. 1, 2, and 3A), as compared with initially forming the container with a deep-set protrusion extending toward the interior of the container (see FIG. 3B). By having the movable region **110** extend away from the interior of the container **100**, the orientation of plastic material in the movable region **110** is increased since the mold would not trap material, but would allow the plastic material to further stretch into a cavity of a mold to form the movable region **110** during blow molding. As the orientation of the plastic molecules increases, the molecules straighten and may form a crystalline structure. Typically, the higher the crystallinity of the plastic, the greater the rigidity of the plastic, which improves the structural integrity of the container **100** at the movable region **110**. A similar process for increasing orientation is also described in co-pending U.S. Provisional Utility Patent

Application No. 60/671,459, filed Apr. 15, 2005, the contents of which are incorporated herein by reference in their entirety.

It is noted that if the container **100** would be initially blow molded into the shape depicted in FIG. 3B, the movable region **110** would not be fully formed at the region near the first hinge or seam **202** and near the second hinge or seam **212**. This is the result of forming a container with the stretch blow molding technique. As a container is being stretch blow molded, gas stretches plastic material against a mold for the container, such as a mold for the container **100**. If the mold contains a protrusion to form the movable region depicted in FIG. 3B, the plastic material would have to stretch around the protrusion from third hinge or seam **208** down to the region near the first hinge or, seam **202** and near the second hinge or seam **212** (see FIG. 3B). The contact with the mold would trap material at the region near the third hinge or seam **208**, and not allow the material to fully form down into the region near the first hinge or seam **202** and near the second hinge or seam **212**. Moreover, forming the movable region **110** with such a protrusion would cause plastic to become trapped at the movable region **110**, which may prevent other areas of the container to not have sufficient plastic to properly form those areas.

Stretch blow molding the container **100** into the shape as illustrated in FIGS. 1, 2, and 3B can also reduce the wall thickness of the movable region **110** and reduces the occurrence of thick amorphous plastic sections near the movable region **110**, as compared with forming the container with the movable region **110** extending outwardly from the container as depicted in FIG. 3A. This may allow the amount of plastic material present in the movable region **110** to be reduced without detrimentally affecting container performance, and, in some instances, this technique improves the performance of the movable region. Likewise, forming the container into the shape as illustrated in FIG. 3A may allow a more uniform distribution of plastic material in the base **108**. Moreover, the increased rigidity may allow for the inversion of the movable region **110** without a substantial net distortion of the container body **106**.

FIGS. 4-6 schematically illustrate a container forming assembly for forming a container from a parison according to one embodiment of the invention. The assembly includes a mold **14a**, **14b**, and **14c** that can be driven by a drive mechanism to enclose parison **12**. A container **100** is blown within the closed mold assembly, as shown in FIG. 5. A recess **16** may be disposed in a sidewall of mold **14a** and mold **14b** to form a two sided grip for a container. FIG. 8 illustrates one side of the mold **814** for forming a container as shown in FIG. 1. In this embodiment each side mold would include a recess **816** that has a first surface **804** adapted to form a first outer grip portion (**204**), a second surface **812** adapted to form a second outer grip portion (**212**), a third surface **806** adapted to form a first inner grip portion (**206**) adjacent the first outer grip portion (**204**), a fourth surface **810** adapted to form a second inner grip portion (**210**), and a fifth surface area **808** adapted to form a ridge area (**208**) of a movable gripping region **110**. The forming assembly may include a first push rod adapted to rotate the first portion **204** of a movable region **110** about first hinge or seam **202** to invert the movable region so that it forms a gripping region. A second push rod may be employed to cause the second portion **212** to rotate about hinge or seam **214** to push both sides of the resultant gripping regions within container **100** prior to filling the container with food product. As shown in FIG. 9, a section **900** of the recess **816** that corresponds with surfaces **806** and

810 and surface area **808** is movable between the inactive position shown in FIG. 8 and the active position shown in FIG. 9.

This system also benefits from requiring less expensive components. While other systems may use complex pneumatic, hydraulic, or cam operated means to push pieces of the mold inward at a specific point in the blow molding cycle, the exemplary embodiments may use a simple mechanical means of inverting the movable region **110**. This reduces the cost, molding time, and complexity of the mold set up as compared with conventional systems.

Thus, the container **100** according to exemplary embodiments of the present invention may improve the sufficient rigidity, definition, and performance of the container **100** at a movable region **110** thereby allowing a container to be formed that uses less plastic while maintaining the performance and appearance of the container. Further, any number of deep set grips or deeply set portions may be provided, such as one, two, three, four, five, or more. The deep set grips can be arranged at various positions along the body of the container, as shown and described herein. Further deep set grips may be formed in the shoulder or dome portion containers as set forth herein, and/or in a base portion, such as a bottom end thereof.

The embodiments and examples discussed herein are non-limiting examples. The shape of the inset are not limited to the examples shown, as the movable region may blown outward in a round or oval forum and, when inverted, still obtain the same function—decrease the volume of the blown container.

Furthermore, FIGS. 11A-11D illustrate an exemplary embodiment of a base assembly **400** according to the present invention. FIG. 11A illustrates a side view of the base assembly **400** having a push rod **446**. FIG. 11B illustrates a side view of the base assembly **400** with a rod end **412** of the push rod **426** extended. FIG. 11C illustrates a top view of the base assembly **400**. FIG. 11D illustrates a cross sectional view of the base assembly **400** along line A-A of FIG. 11C to further depict the push rod **426**. In the following description, reference to FIGS. 11A-11D will be made.

The base assembly **400** includes a base pedestal **402**, a base plug **404**, a centering pin **420**, and a push rod **426**. The centering pin **420** may be used to secure and position the base assembly **400** in a blow molding apparatus (not shown). The base pedestal **402** may have any shape, so long as it has a hollow central region for receiving the push rod **426**, and a top region adapted to connect with the base plug **404**. In an alternative embodiment, the base plug **404** and the base pedestal **402** may be a single apparatus. During blow molding, the base assembly **400** is raised to connect with other mold assemblies for blow molding of a container. After the container is blow molded, the base assembly **400** is lowered to release the container.

The push rod **426** is a cylindrically shaped rod that is located above the centering pin **420** and extends through the base pedestal **402** up to a surface of the base plug **404**. In one embodiment, the push rod **426** is a metal mold component. The base assembly **400** includes a mechanism that moves the push rod **426** and elevates a rod end **412** of the push rod **426** above the surface of the base plug **404**. In an alternative embodiment, only the rod end **412** of the push rod **426** may be elevated. The mechanism for elevating the push rod **426** may be a spring, a cam, or may be driven pneumatically, hydraulically, or electronically. The mechanism may be located internal or external to the push rod **426**. The rod end **412** is formed at the end of the push rod **426**, and the top surface of the rod end **412** is used to form a dimple in the

base of the container. The shape of the rod end **412** is similar to a truncated cone, where the end of the truncated cone includes a section **418**. The section **418** of the rod end **412** may be concave, and the section **418** may be adapted to form a convex section in the base of the container that extends downward away from the center of the container. In alternative embodiments, the section **418** of the rod end **412** may be flat or convex extending upward toward the center of the container. The section **418** is used to reposition a moveable region of the base from an initially outward protruding position to a position within the container cavity, as will be discussed later in detail.

The base plug **404** includes a base mold **406** having a contact surface **408** adapted to contact a parison material during blow molding of a container. The contact surface **408** of the base mold **406** forms the shape of the base of the container. The contact surface **406** is a curvilinear mold for forming a moveable region and a bearing surface of a container base. As will be described later in detail, once the base of the bottle is formed, the moveable region of the base is repositioned from an outwardly protruding position toward the interior of the container. In one embodiment, the movable region is repositioned to a position within the interior of the container, thus forming a container base that is structurally and functionally similar to that of a container having a conventional push up.

The contact surface **408** includes a cavity **410**, a surface **414**, and a surface of the rod end **412**. The surface of the cavity **410** and the surface of the rod end **412** form an inner region **420** of the base mold **406**, and the surface **414** forms an outer region **422** of the base mold **406**, with the outer region **422** being offset from the inner region **420**. The inner region **420** and the outer region **422** are adapted to form a base of a container during blow molding. The outer region **422** is substantially flat and is adapted to form a bearing surface of a container. In an alternative embodiment, the outer region **422** may be non-flat or rounded, or may form a discontinuous bearing surface. The present invention can thus be adapted to form bearing surfaces with geometries known in the art.

When viewing a side cross section of the mold **406**, the cavity **410** is a depression in the base mold **406** that is adapted to form a moveable region in a container. The cavity **410** begins at the outermost edge of the inner region **420**, and curves both inward toward the center of the base mold **406** and downward toward the bottom of the base assembly **400**. Prior to reaching the rod end **412**, the cavity **410** reaches its bottom and begins to curve upward. From the bottom of the cavity **410**, the cavity **410** curves both inward toward the center of the base mold **406** and upward away from the bottom of the base assembly **400**. The cavity **410** ends at the truncated end of the rod end **412**. In an alternative embodiment, the bottom of the rod end **412** may occur at other locations in the base mold **406** relative to the rod end **412**, or may even be positioned on the rod end **412**. When the base mold **406** is viewed from the top, the cavity **410** is a circular depression in the base mold **406** (see FIG. 11C). The cavity **410** is located between the outermost edge of the inner region **420** and the outermost edge of section **418** of the rod end **412**. In an alternative embodiment, the cavity **410** may be any symmetric or asymmetric shape other than a circular depression. For example, the cavity may form a triangle, a rectangle, or a polygon. In a further alternative embodiment, the cavity **410** does not curve upward from its bottom, and instead may curve further downward or may be flat until it reaches the center of the base mold **406**.

FIGS. 12A-12B illustrate an exemplary embodiment using a base assembly **400** to form a base of a container according to the present invention. In FIG. 12A, a parison **304** having a threaded finish is attached to a holder **302** of a blow molding apparatus (not shown) that is adapted to form a blow molded container. Surrounding the parison **304** is a first side mold **306**, a second side mold **308**, and the base assembly **400**. The first side mold **306** contains a mold of one side of the container, and the second side mold **308** contains a mold of the other side. The first side mold **306** and the second side mold **308** may be mirror images of one another, or they may have different shapes. Other combinations and different numbers of molds may be used, as is understood by those of skill in the art.

Prior to blow molding, the parison **304** is enclosed by the first side mold **306**, the second side mold **308**, and the base mold **206**. As illustrated in FIG. 12B, once the parison is enclosed, gas is forced into the parison **304** to inflate the parison **304** in the first side mold **306**, the second side mold **308**, and the base mold **206**. During inflation, the parison **304** stretches into the form of the first side mold **306**, the second side mold **308**, and the base mold **406**. As the parison material contacts the base mold **406**, the parison material is blown against the contact surface **408** into the cavity **410**. The parison material stretches into the cavity **410** to form a moveable region in the base of the container.

By having the cavity **410** in the base mold **406**, the parison material does not encounter a deep protrusion, which would cause cooling and would reduce plastic material orientation. Stretching the parison material during inflation into the cavity **410**, as opposed to around a protrusion, allows the parison material to further stretch and orient since the parison material is blown into a wider space as compared with a narrow recess around a deep protrusion. The additional stretch increases the crystallinity of the molecules of the parison material, which increases the rigidity of the base and improves the structural integrity of the base. Blow molding the parison material into the cavity **410** also reduces the wall thickness of the base and reduces the occurrence of thick amorphous plastic sections in the base. Thus, the amount of plastic material present in the base can be reduced without detrimentally affecting container performance, and, in some instances, this technique improves the performance of the base.

FIG. 13A illustrates an exemplary embodiment of the push rod **426** repositioning the base of the container according to the present invention. In this embodiment, prior to separating the first side mold **306**, the second side mold **308**, and the base assembly **400** from the container, the base of the container is repositioned. After the inflation process of the parison **304** has completed, a base having a moveable region that protrudes outward from the container is formed at the cavity **410**. The moveable region of the container base is downwardly convex with respect to a bearing surface, as is described below in detail. The push rod **426** is then elevated upward toward the center of the container to elevate the rod end **412** above the contact surface **408** to exert pressure on the moveable region of the base. As the rod end **412** is further elevated, the moveable region is forced upward toward the center of the container into an upward position, which extends inward into the interior of the container with respect to the bearing surface. After the moveable region is repositioned upward, the push rod **426** may be lowered. Thereafter, the first side mold **306**, the second side mold **308**, and the base assembly **400** may release the blow molded container by separating.

FIG. 13B illustrates an alternative exemplary embodiment of the push rod 426 repositioning the base of the container according to the present invention. In this embodiment, the base assembly 400 separates from the first side mold 306 and the second side mold 308 to release the base of the container. Afterwards, the rod end 412 is elevated until it reaches the moveable region of the container base. The rod end 412 then exerts pressure on the base of the container to reposition the moveable region of the base. Thereafter, the first side mold 306 and the second side mold 308 may release the blow molded container by separating so that the container may be further processed. In still other embodiments, the base of the container may be released from the molds without being repositioned and sent to a different device for repositioning the moveable region.

FIGS. 14A and 14B illustrate an exemplary embodiment of a container 500 prior to and after repositioning by the push rod 406 according to the present invention. Prior to repositioning, the base includes a moveable region 502 and a bearing surface 504, where at least a portion of the moveable region 502 protrudes outward from the base of the container beyond the bearing surface 504. The moveable region 502 of the container base is downwardly convex with respect to the bearing surface 504. During inflation using base mold 406, the moveable region 502 is formed by the inner region 420 of the base mold 406, and the bearing surface 504 is formed by the outer region 422. The moveable region 502 protrudes outward from an innermost edge of the bearing surface 504 away from the center of the container and is downwardly convex with respect to the bearing surface 504. The moveable region 502 is illustrated as being circular, but may be any symmetrical or asymmetrical shape. A dimple 518 is formed at a center of the moveable region 502 by the surface of the rod end 412 of the contact surface 408. The dimple 518 is upwardly convex and protrudes inward toward the center of the container 500. The dimple 518 provides a pocket in which the rod end 412 can be situated as the push rod 426 extends to reposition the moveable region 502 of the base.

During repositioning, the moveable region 502 is moved toward the center interior of the container by the extension of the rod end 412. In one embodiment, the moveable region 502 is moved within the interior of the container with respect to the bearing surface 504. In repositioning, the rod end 412 contacts the dimple 518 and forces the dimple 518 toward the center of the container. This repositions the moveable region 502 and causes the moveable region 502 to no longer extend or protrude beyond the bearing surface 504. In an alternative embodiment, the rod end 412 may contact the moveable region 502 at other locations to reposition the moveable region 502 of the base, as would be understood by those of ordinary skill in the art. In one embodiment, repositioning of the base occurs before the container is filled so that the container may be placed on a substantially flat surface for transport to, for example, a filling machine, or alternatively, for transport during manufacturing or for palletizing, as is known in the art. The filling machine may fill the container by any known filling process, including hot filling, cold filling, and other filling processes known by those skilled in the art. By repositioning the moveable region 502, the container can stand stably on a substantially flat surface and be processed similar to containers with conventionally manufactured push up bases. Thus, the base region, after repositioning the moveable region 502, has the appearance and functionality of a conventional blow molded base with a push up, without the disadvantages of the prior art.

The container 500 has a one-piece construction and can be prepared from a monolayer plastic material, such as a polyamide, for example, nylon; a polyolefin such as polyethylene, for example, low density polyethylene (LDPE) or high density polyethylene (HDPE), or polypropylene; a polyester, for example polyethylene terephthalate (PET), polyethylene naphthalate (PEN); or others, which can also include additives to vary the physical or chemical properties of the material. For example, some plastic resins can be modified to improve the oxygen permeability. Alternatively, the container 500 can be prepared from a multilayer plastic material. The layers can be any plastic material, including virgin, recycled and reground material, and can include plastics or other materials with additives to improve physical properties of the container. In addition to the above-mentioned materials, other materials often used in multilayer plastic containers include, for example, ethylvinyl alcohol (EVOH) and tie layers or binders to hold together materials that are subject to delamination when used in adjacent layers. A coating may be applied over the monolayer or multilayer material, for example to introduce oxygen barrier properties. Thus, containers according to embodiments of the invention can have body portions and grips (e.g., handles) formed of a same material.

Although the present embodiment and the figures illustrated the parison 304 as a preform having threads at the top, the parison may also be a threadless plastic tube without departing from the scope of the invention. One example using a parison that is a plastic tube involves inserting a needle into the parison, and forcing gas through the needle to expand the plastic tube to take the shape of a mold. Additionally, any blow molding technique may be used for forming the container, including injection blow molding, stretch blow molding, or extrusion blow molding, as would be understood by those of skill in the art.

It is noted that the detailed description describes a technique for blow molding a moveable region 502 on a container base by molding a parison material into a cavity 410. However, this technique may be used to form other regions of a container other than the base, such as to form at least a portion of a hand grip of a container, or to form other deep protrusions of a container. The cavity 410 may also be located on either side mold 306 or 308, or on other locations in the base mold 406. This technique is useable on any region of a plastic container where a deep protrusion is required. The technique described herein increases the rigidity of a region having a deep protrusion, while reducing thick amorphous plastic sections around the region caused by the deep protrusion.

The exemplary embodiments illustrated and discussed in this specification are intended only to teach those skilled in the art the best way known to the inventors to make and use the invention. Nothing in this specification should be considered as limiting the scope of the present invention. All examples presented are representative and non-limiting. The above-described exemplary embodiments of the invention maybe modified or varied, without departing from the invention, as appreciated by those skilled in the art in light of the above teachings. It is therefore to be understood that, within the scope of the claims and their equivalents, the invention may be practiced otherwise than as specifically described.

What is claimed is:

1. An injection stretch blow molded plastic bottle comprising:
 - a threaded neck portion defining an opening into the plastic bottle;

- a body portion having a sidewall and a plurality of deep-set grips, each said deep-set grip having a first surface portion and first hinge, and a second surface portion and second hinge, each hinge having a wall thickness being thinner than immediately surrounding portions of the sidewall on both sides of the hinge, the first surface portion and the second surface portion each configured to rotate, in response to a force applied thereupon, about the first hinge and the second hinge, respectively, from an as-formed configuration extending away from an interior of the bottle to a final, deep-set configuration extending inwardly toward the interior of the bottle; and
 - a base portion defining a standing surface of the plastic bottle.
2. The bottle according to claim 1, wherein the plurality of deep-set grips form one deep-set handle in the deep-set configuration.
 3. The bottle according to claim 1, wherein the inward depth of each said deep-set grips is greater than 25 mm inward from the corresponding hinge in the deep-set configuration.
 4. The bottle according to claim 1, wherein each said deep-set grip is arranged in an upper third portion of the sidewall.
 5. The bottle according to claim 1, wherein each said deep-set grip is arranged in an upper quarter of the bottle.
 6. The bottle according to claim 1, wherein said plurality of deep-set grips includes a: first deep-set grip on a first side of the bottle and a second deep-set grip on a second side of the bottle, the first deep-set grip being a mirror image of the second deep-set grip.
 7. The bottle according to claim 1, wherein said plurality of deep-set grips includes a first deep-set grip on a first side of the bottle and a second deep-set grip on a second side of the bottle, the first deep-set grip being identical in configuration to the second deep-set grip.
 8. The bottle according to claim 1, wherein said plurality of deep-set grips includes a first deep-set grip on a first side of the bottle and a second deep-set grip on a second side of the bottle, and the sidewall further including smooth portions separating the first and second deep-set grips.
 9. The bottle according to claim 1, wherein said plurality of deep-set grips includes a first deep-set grip and a second deep-set grip, the first deep-set grip and the second deep-set

- grip being arranged centrally about the sidewall in a longitudinal or height direction of the plastic bottle.
10. The bottle according to claim 1, wherein the bottle is in the form of an hour-glass in side view.
 11. A plastic container, comprising:
 - a neck portion defining an opening into the finally formed plastic container;
 - a body portion having a sidewall and one or more deeply recessed portions, each said deeply recessed portion having a first surface portion and first hinge, and a second surface portion and second hinge, each hinge having a wall thickness being thinner than immediately surrounding portions of the sidewall on both sides of the hinge, each said deeply recessed portion being configured to invert, in response to a force applied thereupon, from an as-formed configuration extending away from an interior of the container to a final, deeply recessed configuration extending inwardly toward an interior of the container; and
 - a base portion defining a standing support for the plastic container to stand in an upright position.
 12. The finally formed plastic container according to claim 11, wherein at least one of said one or more deeply recessed portions has a length greater than a width thereof, with the length running in a direction perpendicular to a longitudinal axis of the finally formed container.
 13. The finally formed plastic container according to claim 11, wherein said one or more deeply recessed portions includes a first deeply recessed portion and a second deeply recessed portion, the first and second deeply recessed portions having overlapping and touching portions thereof.
 14. The finally formed plastic container according to claim 11, wherein the first hinge is separate and spaced from the second hinge by at least the first and second surface portions.
 15. The bottle according to claim 1, wherein the first hinge is separate and spaced from the second hinge by at least the first and second surface portions.
 16. The finally formed plastic container according to claim 11, wherein each of the first and second surface portions has a smooth surface free of any protrusions.
 17. The bottle according to claim 1, wherein each of the first and second surface portions has a smooth surface free of any protrusions.

* * * * *