



US009704629B2

(12) **United States Patent**
Ikriannikov

(10) **Patent No.:** **US 9,704,629 B2**
(45) **Date of Patent:** **Jul. 11, 2017**

(54) **COUPLED INDUCTORS WITH
NON-UNIFORM WINDING TERMINAL
DISTRIBUTIONS**

(71) Applicant: **Volterra Semiconductor LLC**, San Jose, CA (US)

(72) Inventor: **Alexandr Ikriannikov**, Castro Valley, CA (US)

(73) Assignee: **Volterra Semiconductor LLC**, San Jose, CA (US)

(*) Notice: Subject to any disclaimer, the term of this patent is extended or adjusted under 35 U.S.C. 154(b) by 0 days.

(21) Appl. No.: **15/018,318**

(22) Filed: **Feb. 8, 2016**

(65) **Prior Publication Data**

US 2016/0155551 A1 Jun. 2, 2016

Related U.S. Application Data

(62) Division of application No. 13/802,363, filed on Mar. 13, 2013, now Pat. No. 9,287,038.

(51) **Int. Cl.**

- H01F 5/00** (2006.01)
- H01F 27/02** (2006.01)
- H01F 27/28** (2006.01)
- H01F 17/06** (2006.01)
- H01F 27/24** (2006.01)
- H01F 17/04** (2006.01)
- H01F 3/12** (2006.01)
- H01F 30/12** (2006.01)
- H02M 3/158** (2006.01)

(52) **U.S. Cl.**

CPC **H01F 3/12** (2013.01); **H01F 17/04** (2013.01); **H01F 30/12** (2013.01); **H02M 3/1584** (2013.01)

(58) **Field of Classification Search**

CPC H01F 5/00; H01F 27/28
USPC 336/83, 170, 178, 200, 212, 214, 215, 336/220, 221, 222, 232

See application file for complete search history.

(56) **References Cited**

U.S. PATENT DOCUMENTS

- 2,170,446 A 8/1939 Edwards
- 2,212,543 A 8/1940 Jovy
- 2,298,935 A 10/1942 Freeman
- 2,403,393 A 7/1946 Peterson
- 3,447,068 A 5/1969 Hart
- 3,671,847 A 6/1972 Shibano
- 3,878,495 A 4/1975 Thomas
- 4,488,136 A 12/1984 Hansen et al.

(Continued)

FOREIGN PATENT DOCUMENTS

WO WO 2006/026674 3/2006

OTHER PUBLICATIONS

Dong et al., The Short Winding Path Coupled Inductor Voltage Regulators, 2008, IEEE, pp. 1446-1452.*

Primary Examiner — Tsz Chan

(74) *Attorney, Agent, or Firm* — Lathrop & Gage LLP

(57) **ABSTRACT**

A coupled inductor includes a ladder magnetic core including two opposing rails extending in a lengthwise direction and joined by a plurality of rungs. The coupled inductor further includes a respective winding wound around each of the plurality of rungs. The plurality of rungs are divided into at least two groups of rungs, and a lengthwise separation distance between adjacent rungs in each group of rungs is less than a lengthwise separation distance between adjacent rungs of different groups of rungs.

11 Claims, 26 Drawing Sheets

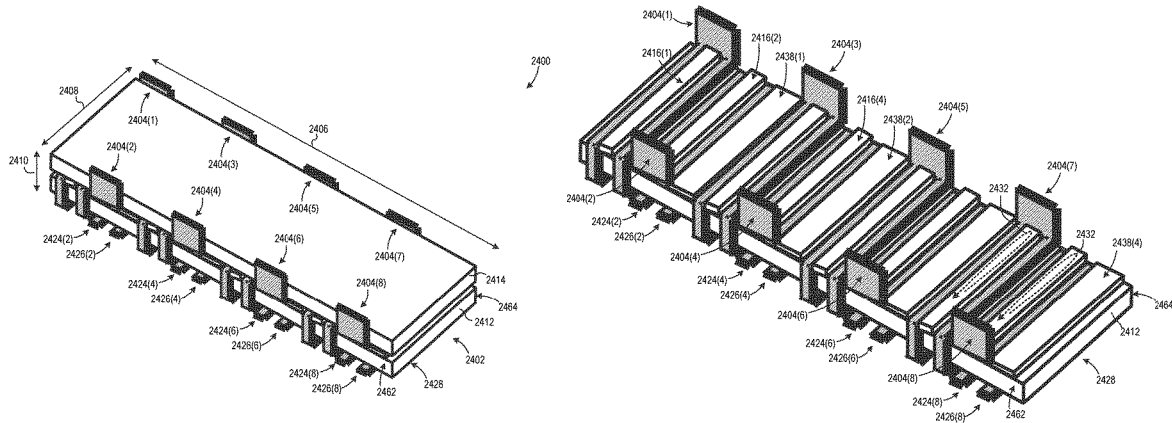

(56)

References Cited

U.S. PATENT DOCUMENTS

5,003,277	A	3/1991	Sokai et al.	7,994,888	B2	8/2011	Ikriannikov
5,177,460	A	1/1993	Dhyanchand et al.	2004/0130426	A1	7/2004	Suzuki
5,182,535	A	1/1993	Dhyanchand	2005/0024179	A1	2/2005	Chandrasekaran et al.
5,436,818	A	7/1995	Barthold	2006/0197510	A1	9/2006	Chandrasekaran
5,525,951	A	6/1996	Sunano et al.	2007/0175701	A1	8/2007	Xu et al.
5,737,203	A	4/1998	Barrett	2007/0176726	A1	8/2007	Xu et al.
5,847,518	A	12/1998	Ishiwaki	2009/0179723	A1	7/2009	Ikriannikov et al.
6,018,468	A	1/2000	Archer et al.	2009/0231081	A1	9/2009	Ikriannikov et al.
6,060,977	A	5/2000	Yamamoto et al.	2009/0237197	A1	9/2009	Ikriannikov et al.
6,147,584	A	11/2000	Shin'el	2010/0007457	A1	1/2010	Yan et al.
6,304,460	B1	10/2001	Cuk	2010/0171580	A1	7/2010	Abe et al.
6,348,848	B1	2/2002	Herbert	2011/0018669	A1	1/2011	Ikriannikov
6,362,986	B1	3/2002	Schultz et al.	2011/0032068	A1	2/2011	Ikriannikov
6,377,155	B1	4/2002	Allen et al.	2011/0035607	A1	2/2011	Ikriannikov
6,388,896	B1	5/2002	Cuk	2011/0043317	A1	2/2011	Ikriannikov
6,714,428	B2	3/2004	Huang et al.	2011/0050191	A1	3/2011	Tsuji et al.
6,737,951	B1	5/2004	Decristofaro et al.	2011/0148559	A1	6/2011	Ikriannikov
6,784,644	B2	8/2004	Xu et al.	2011/0148560	A1	6/2011	Ikriannikov
6,856,230	B2	2/2005	Lu	2011/0169476	A1	7/2011	Ikriannikov
6,980,077	B1	12/2005	Chandrasekaran et al.	2011/0260822	A1	10/2011	Ikriannikov
7,352,269	B2	4/2008	Li et al.	2011/0279100	A1	11/2011	Ikriannikov
7,456,719	B2*	11/2008	Suzuki H01F 38/10 336/198	2011/0279212	A1	11/2011	Ikriannikov
7,498,920	B2	3/2009	Sullivan et al.	2011/0286143	A1	11/2011	Ikriannikov
7,567,163	B2*	7/2009	Dadafshar H01F 27/2847 336/178	2011/0286144	A1	11/2011	Ikriannikov
7,880,577	B1	2/2011	Glaser et al.	2012/0056703	A1*	3/2012	Ikriannikov H01F 17/04 336/105
				2012/0056704	A1	3/2012	Nagano et al.

* cited by examiner

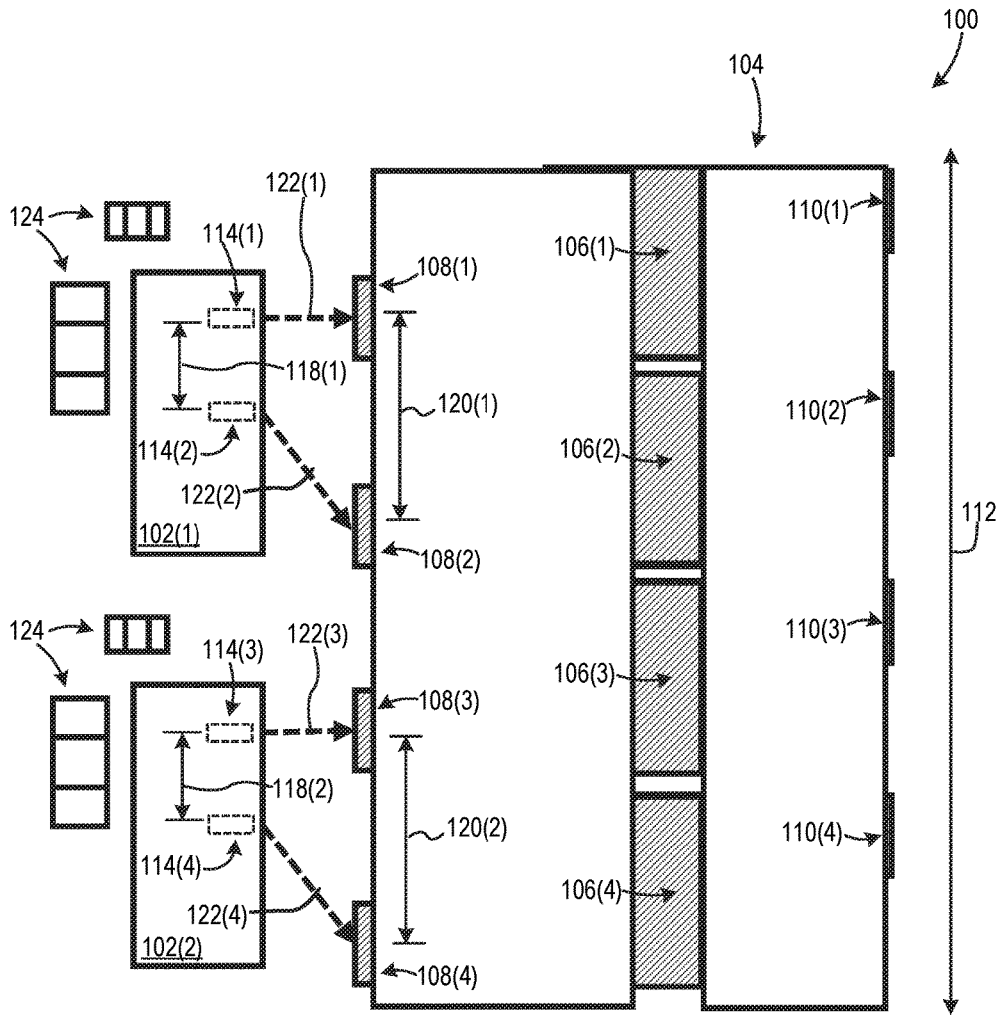

(PRIOR ART)

FIG. 1

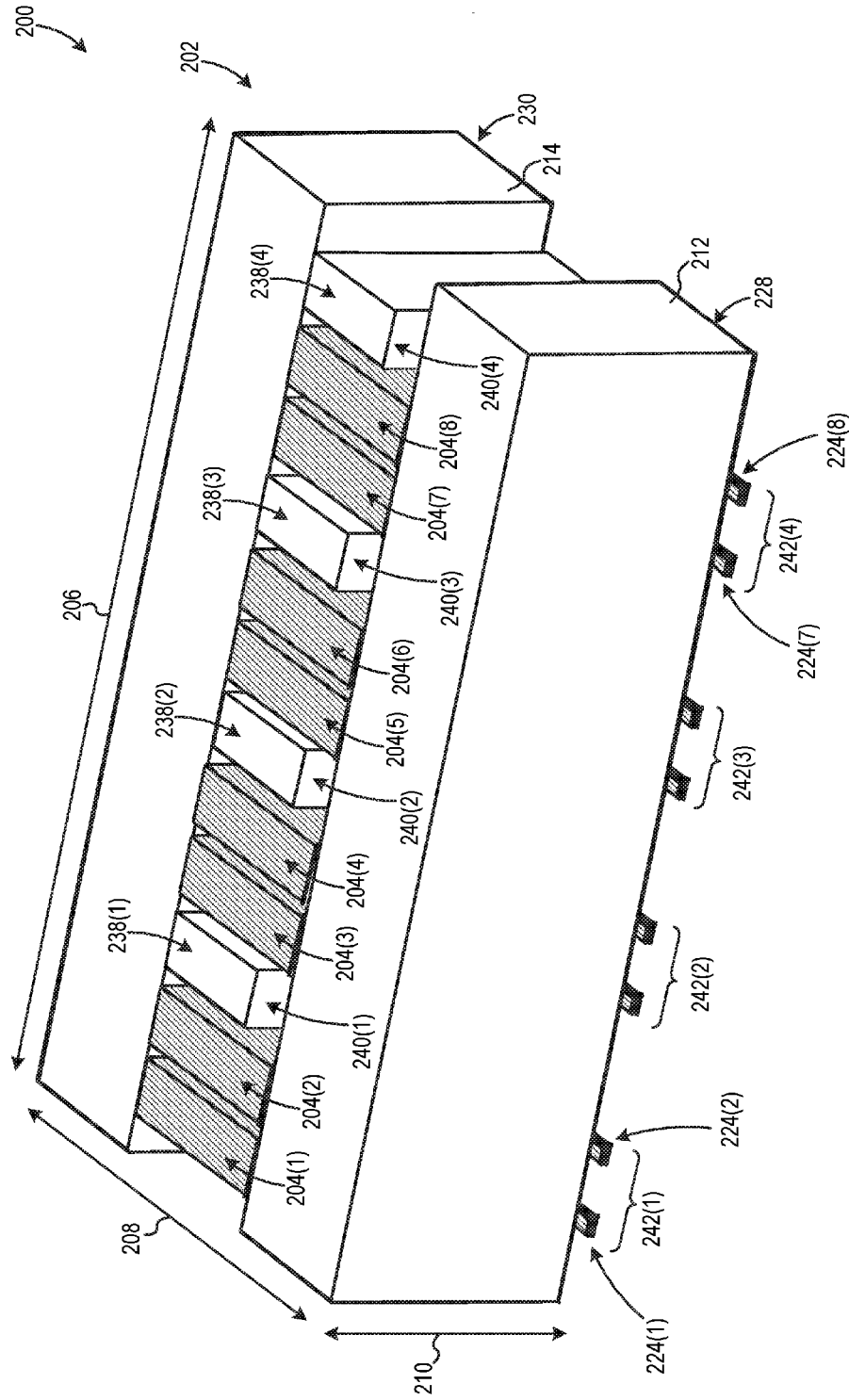

FIG. 2

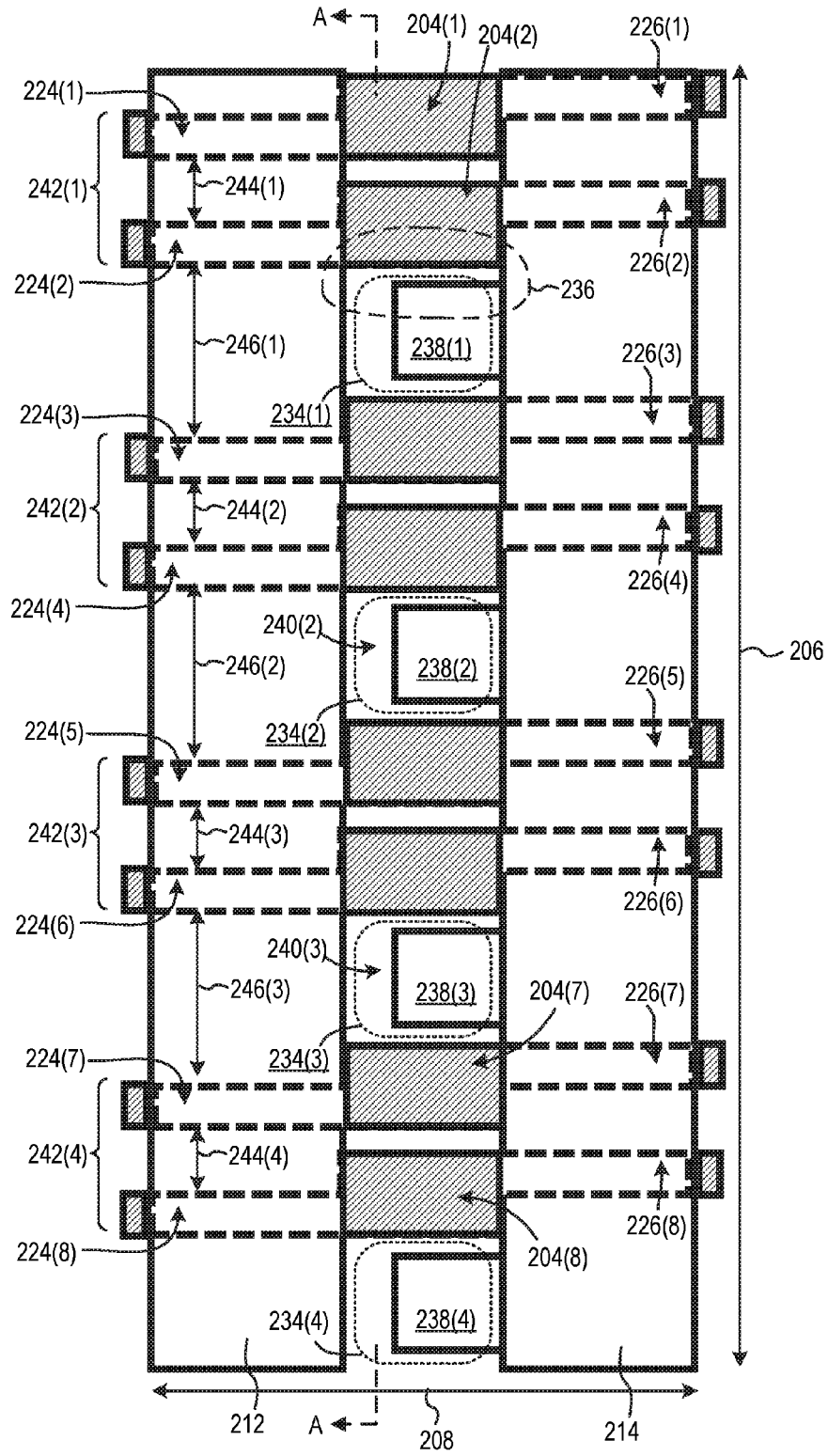

FIG. 3

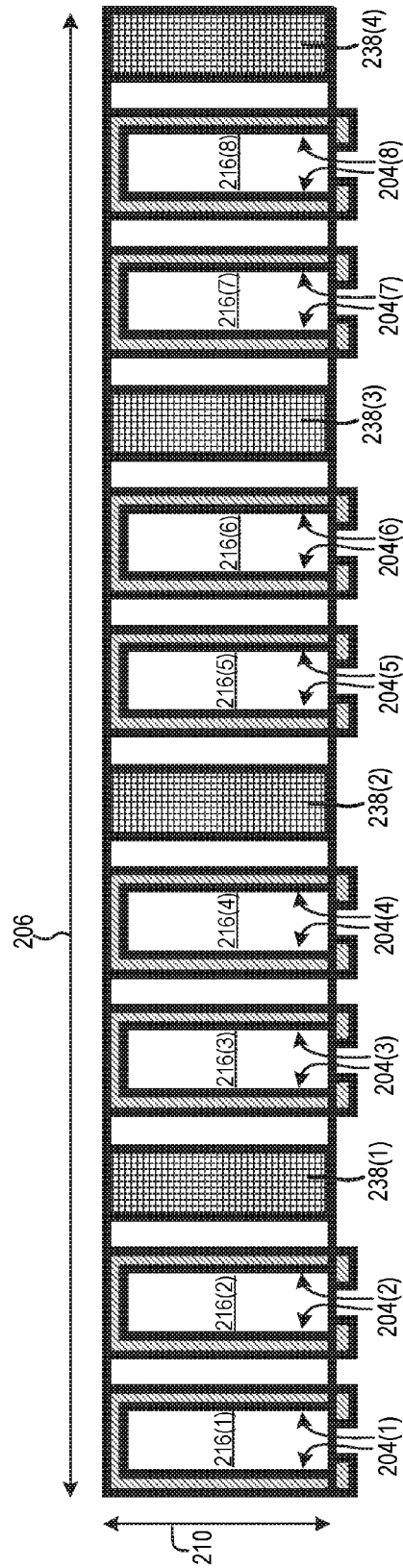

FIG. 4

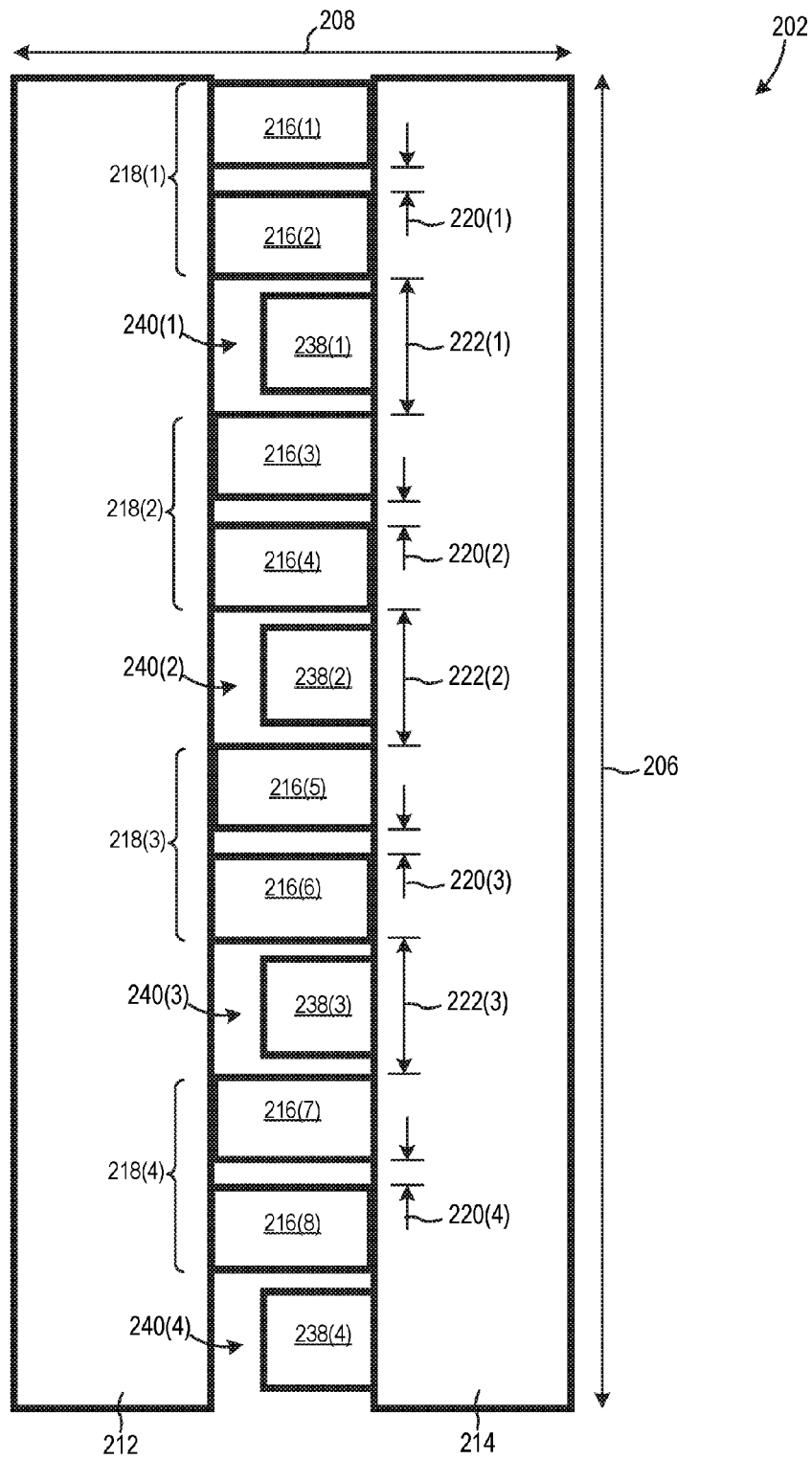

FIG. 5

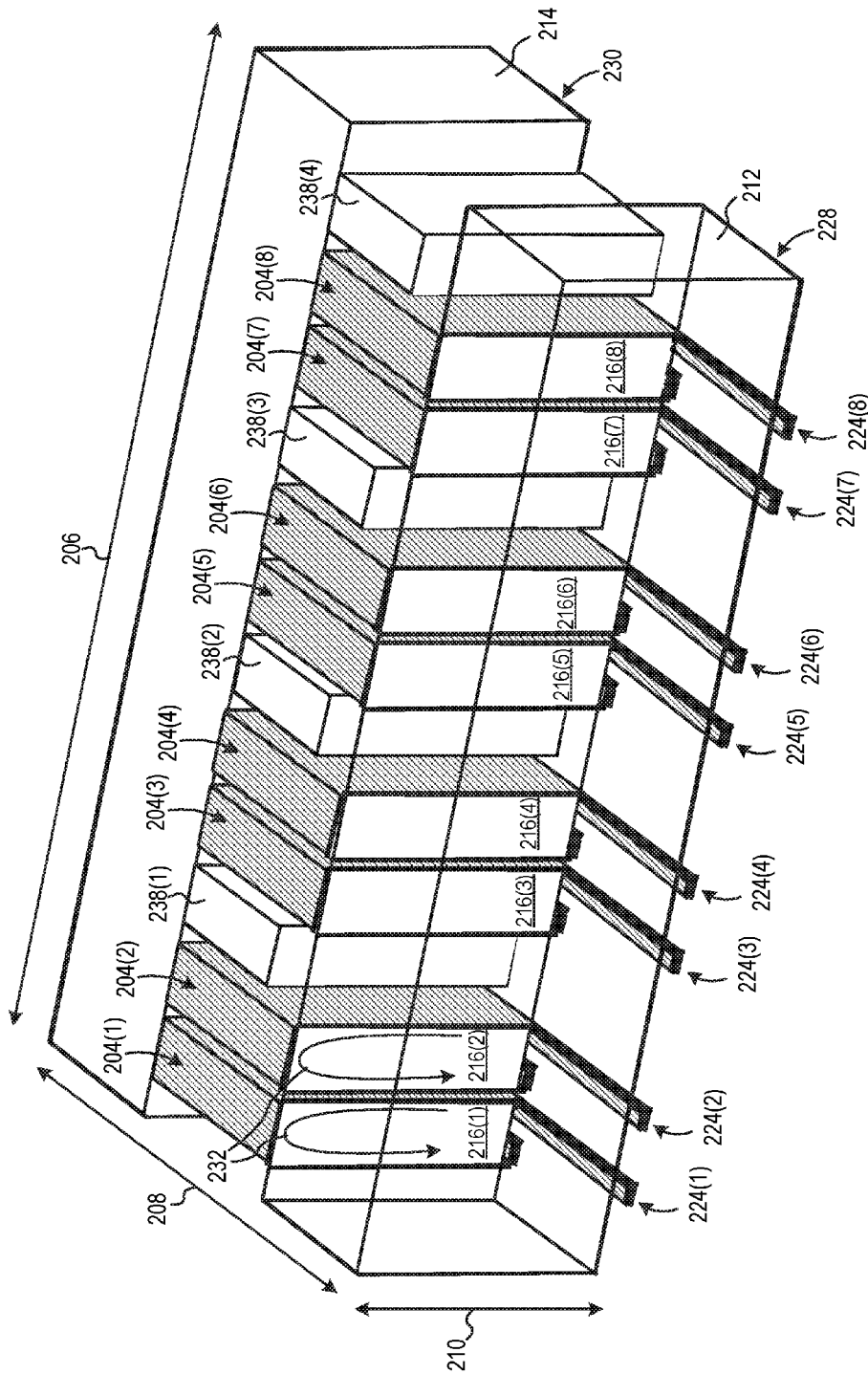

FIG. 6

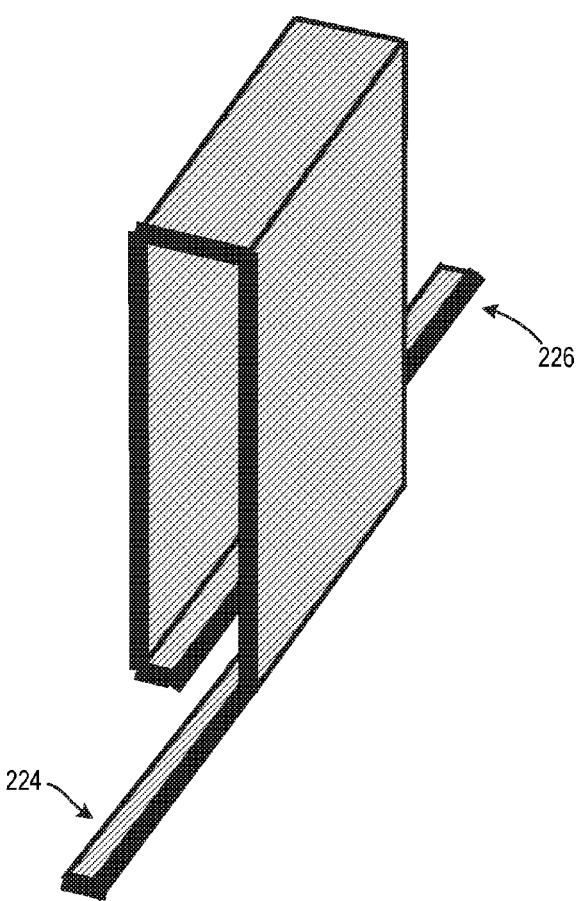

FIG. 7

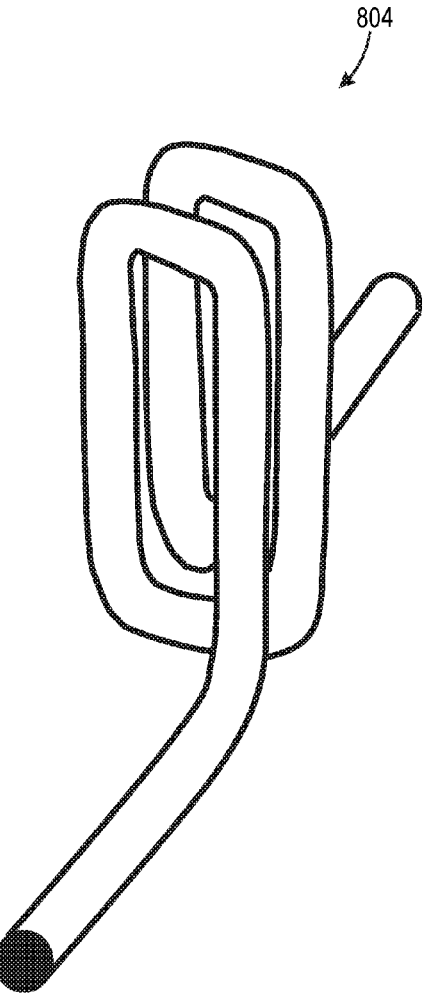

FIG. 8

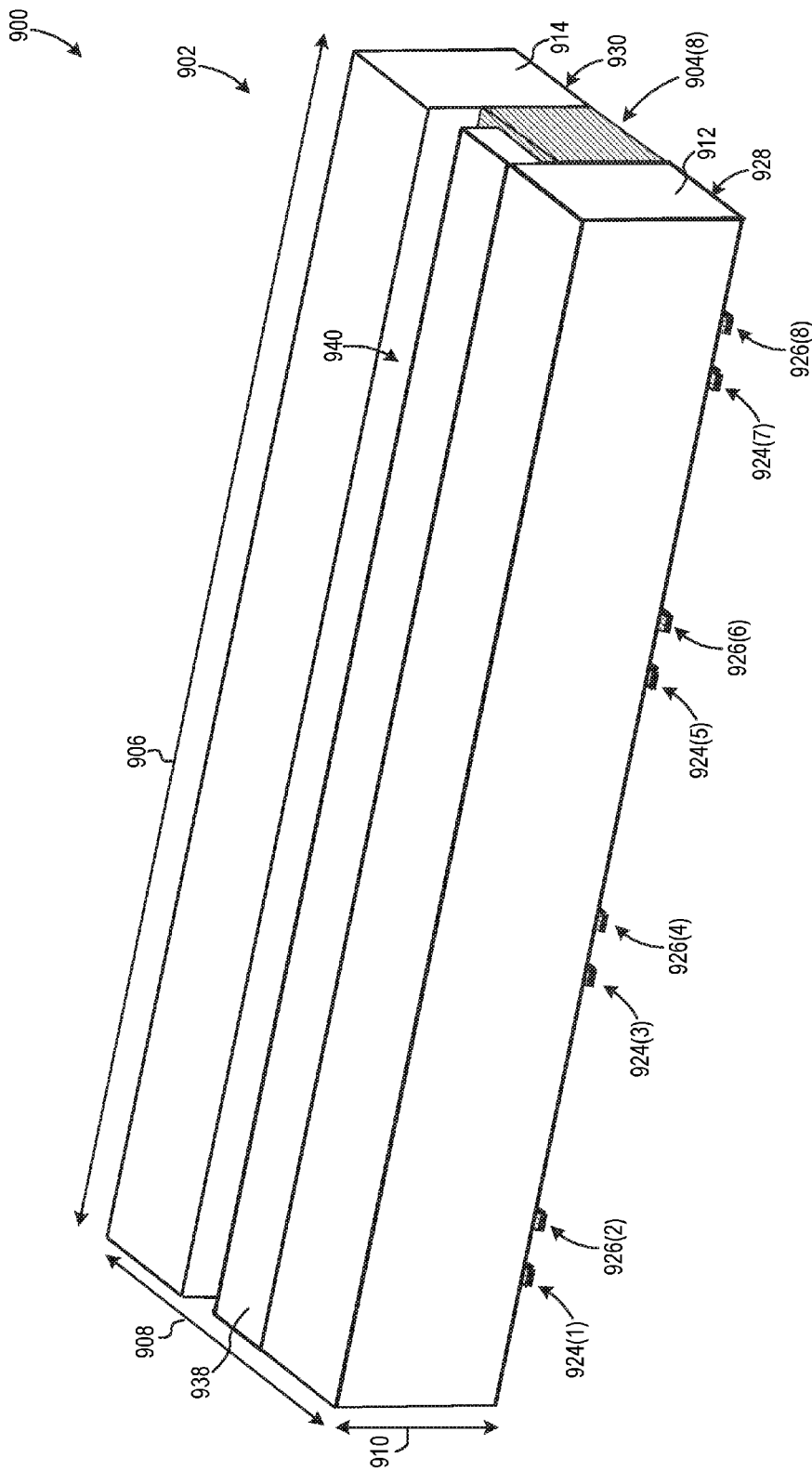

FIG. 9

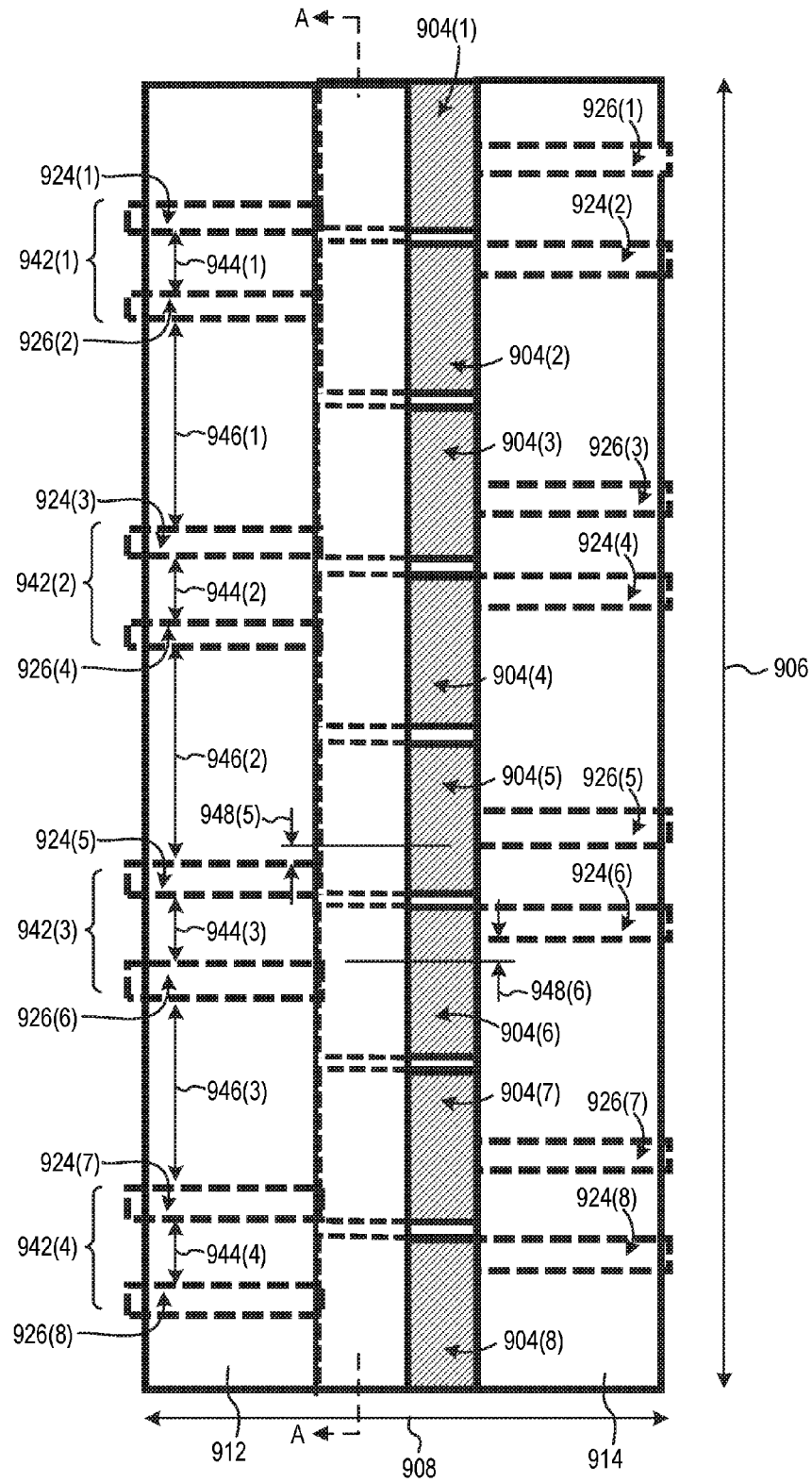

FIG. 10

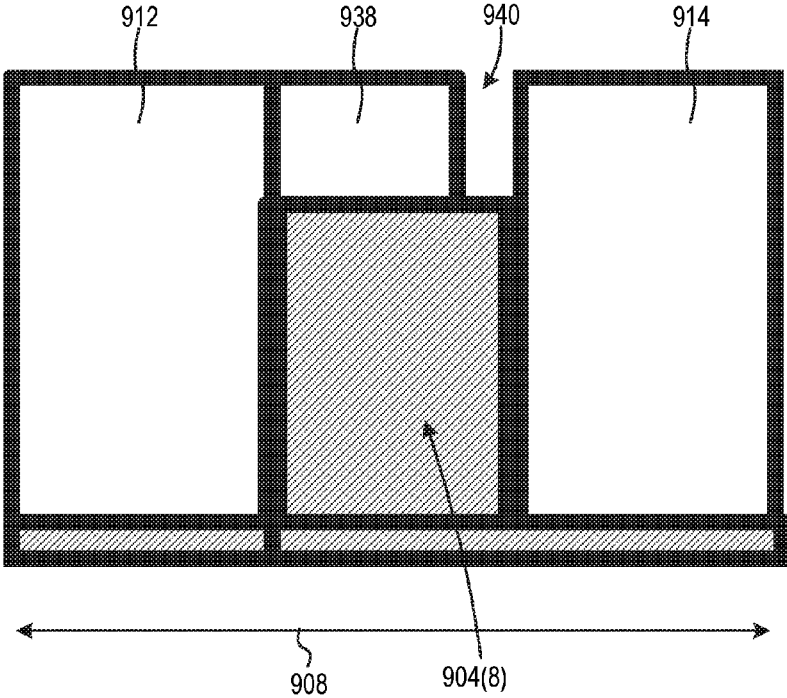

FIG. 11

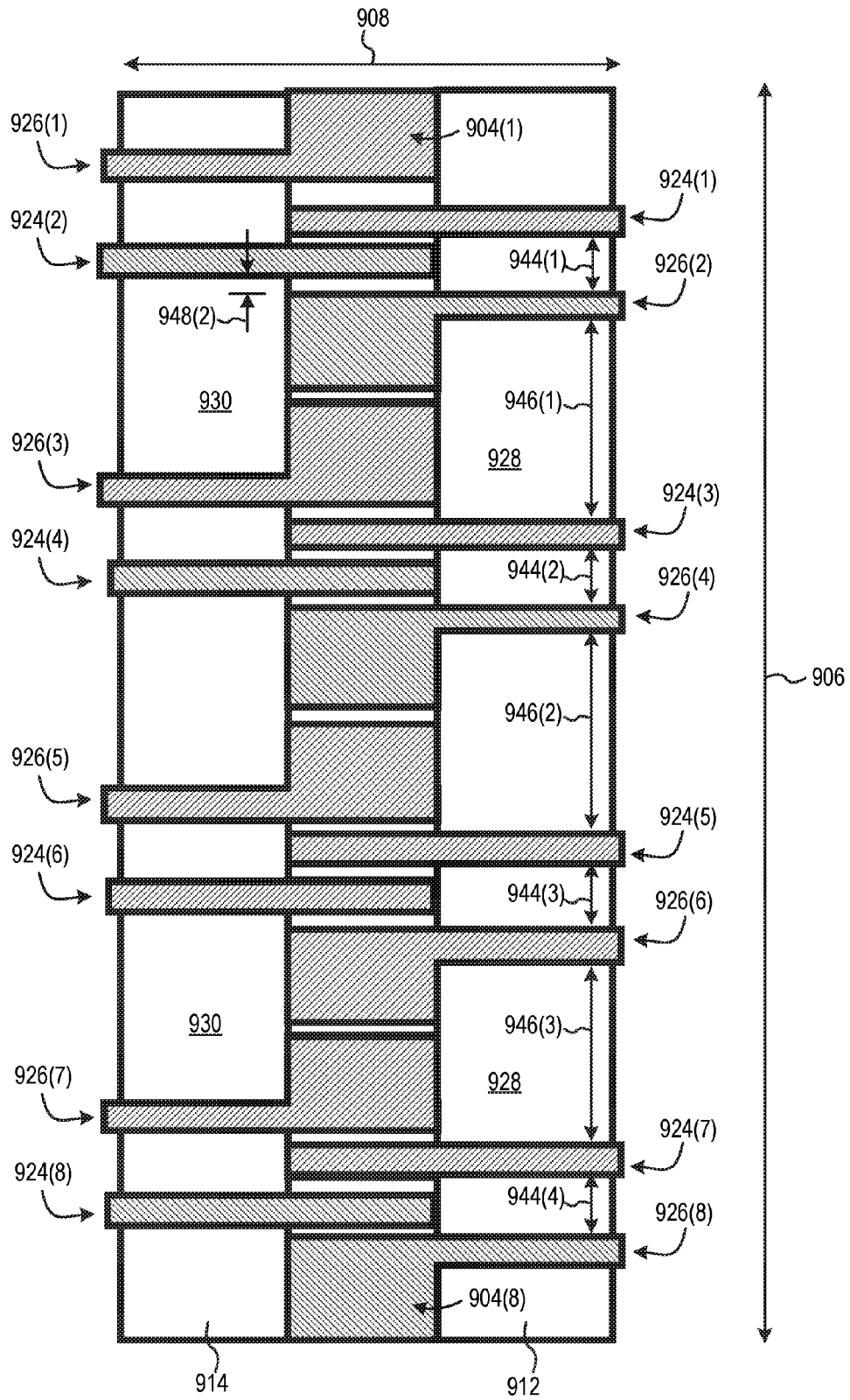

FIG. 12

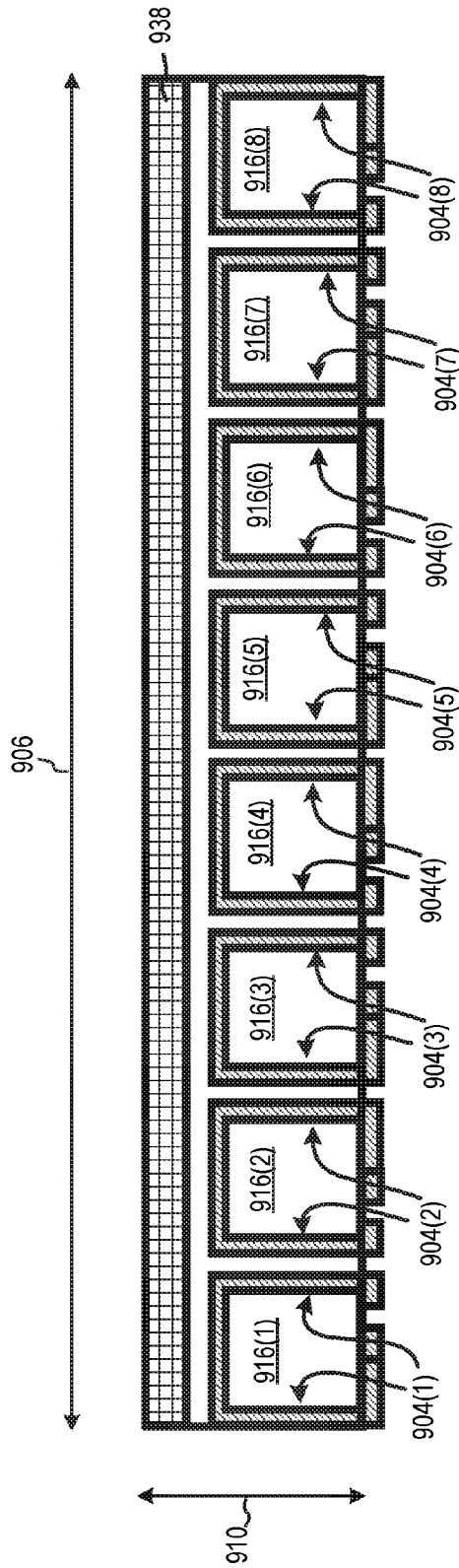

FIG. 13

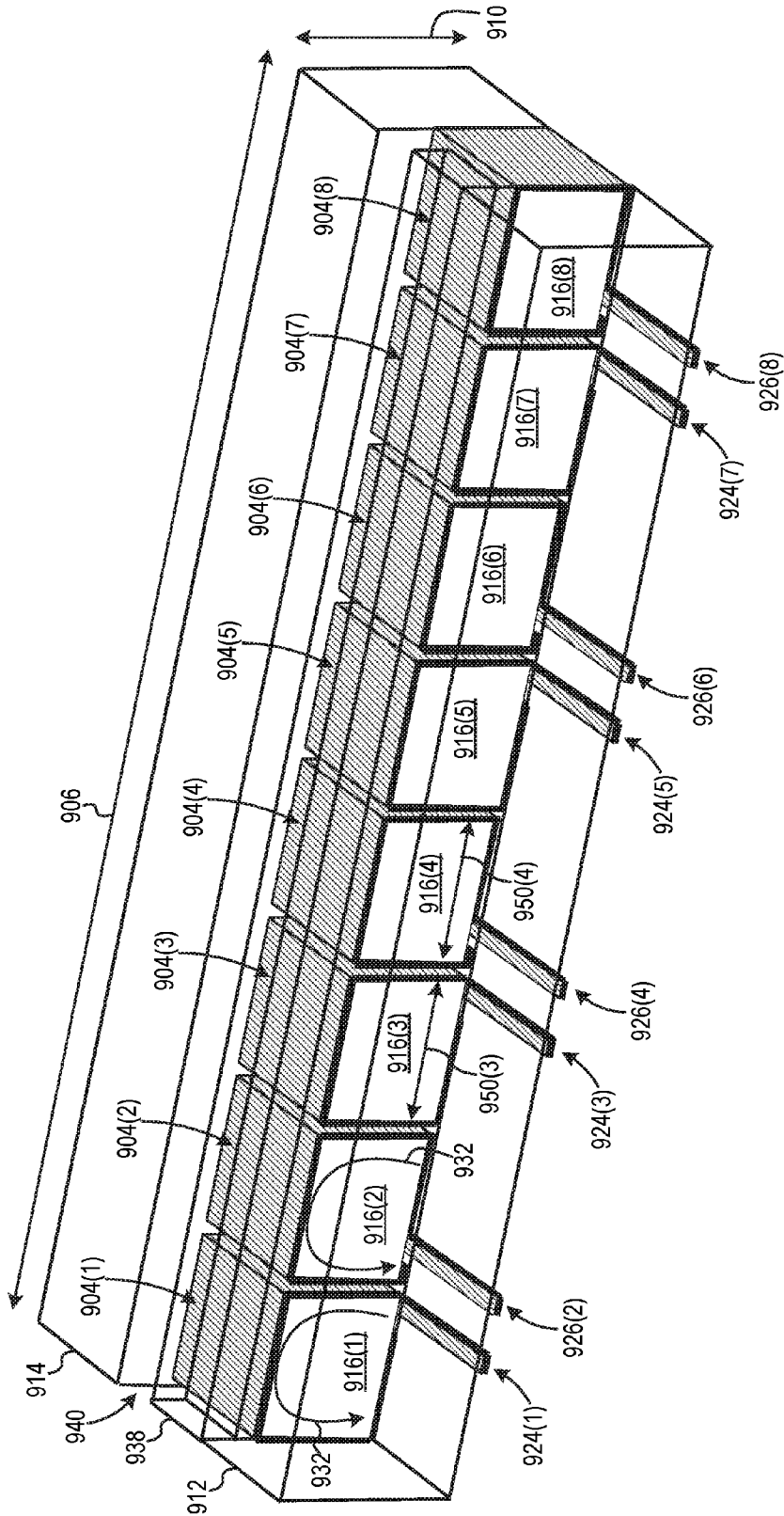

FIG. 14

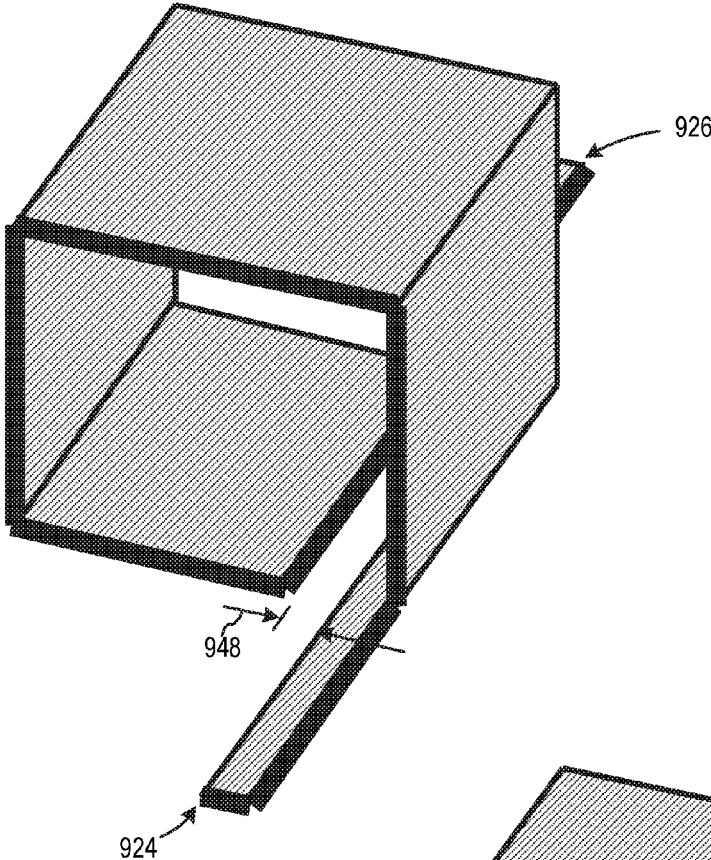

FIG. 15

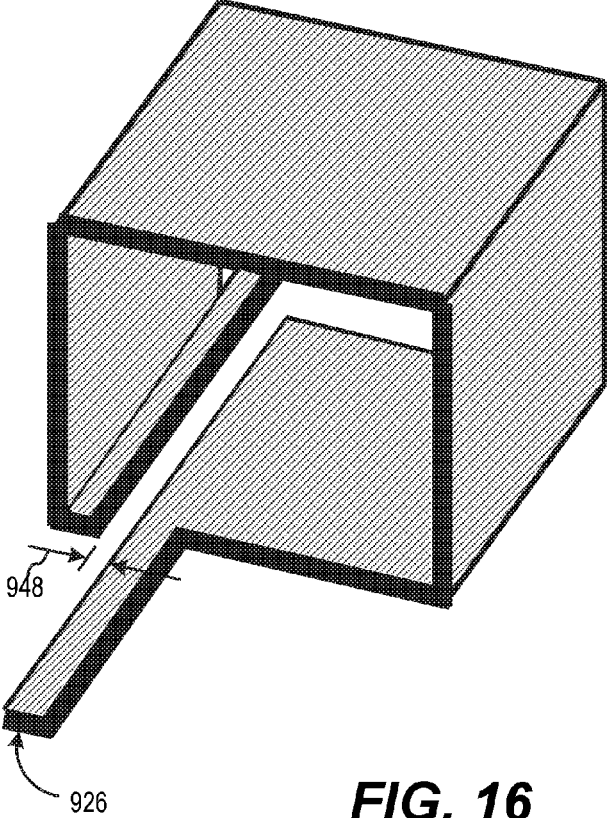

FIG. 16

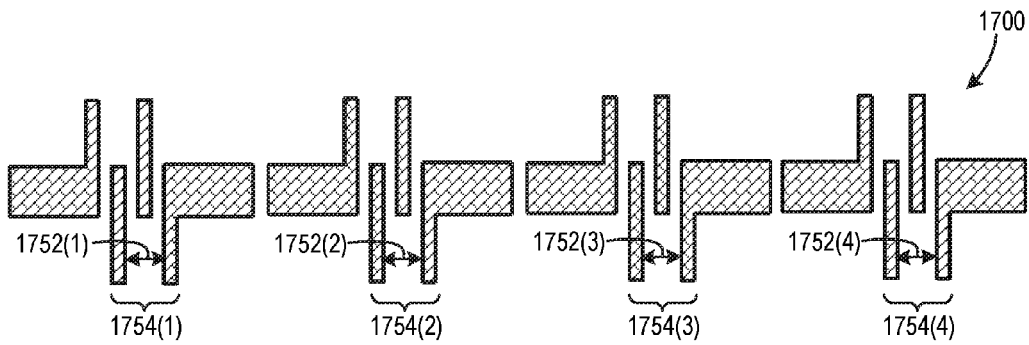

FIG. 17

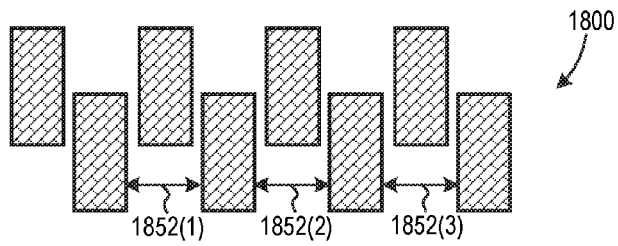

FIG. 18

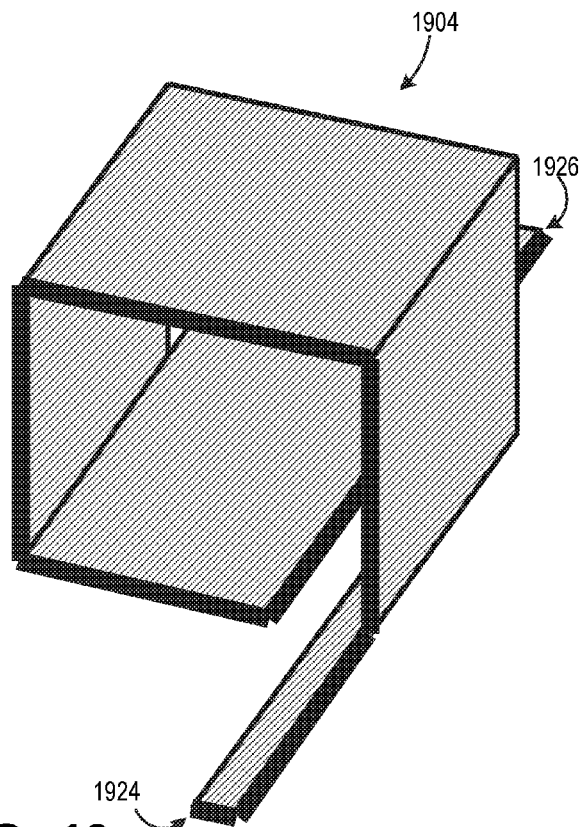

FIG. 19

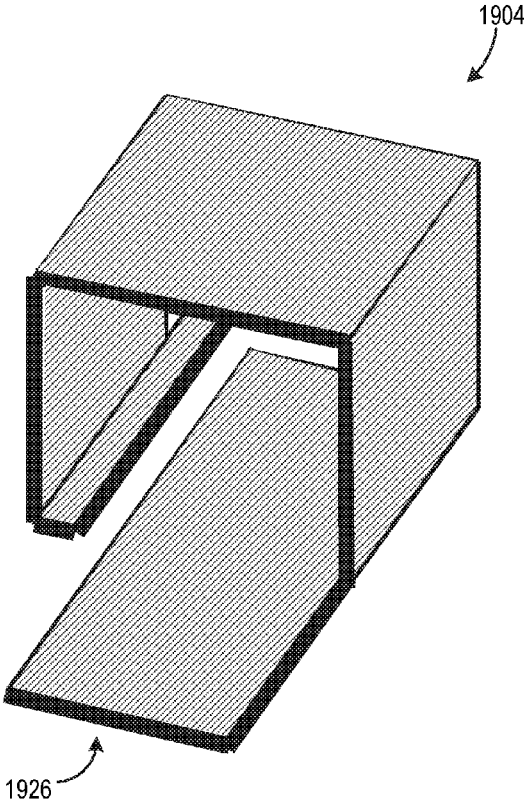

FIG. 20

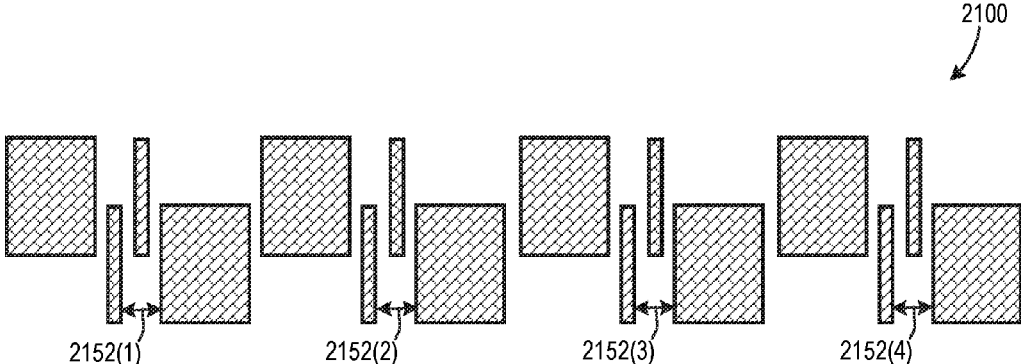

FIG. 21

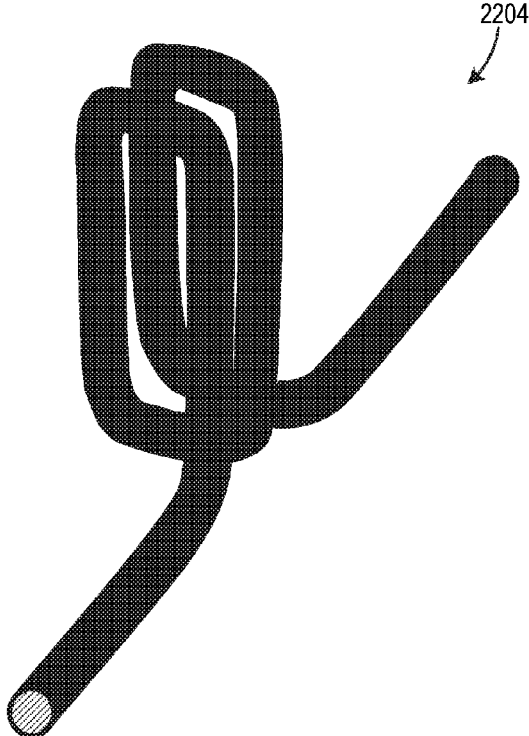

FIG. 22

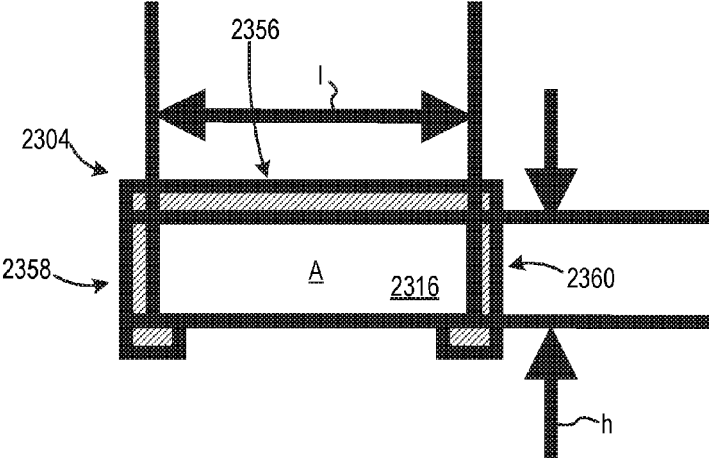

FIG. 23

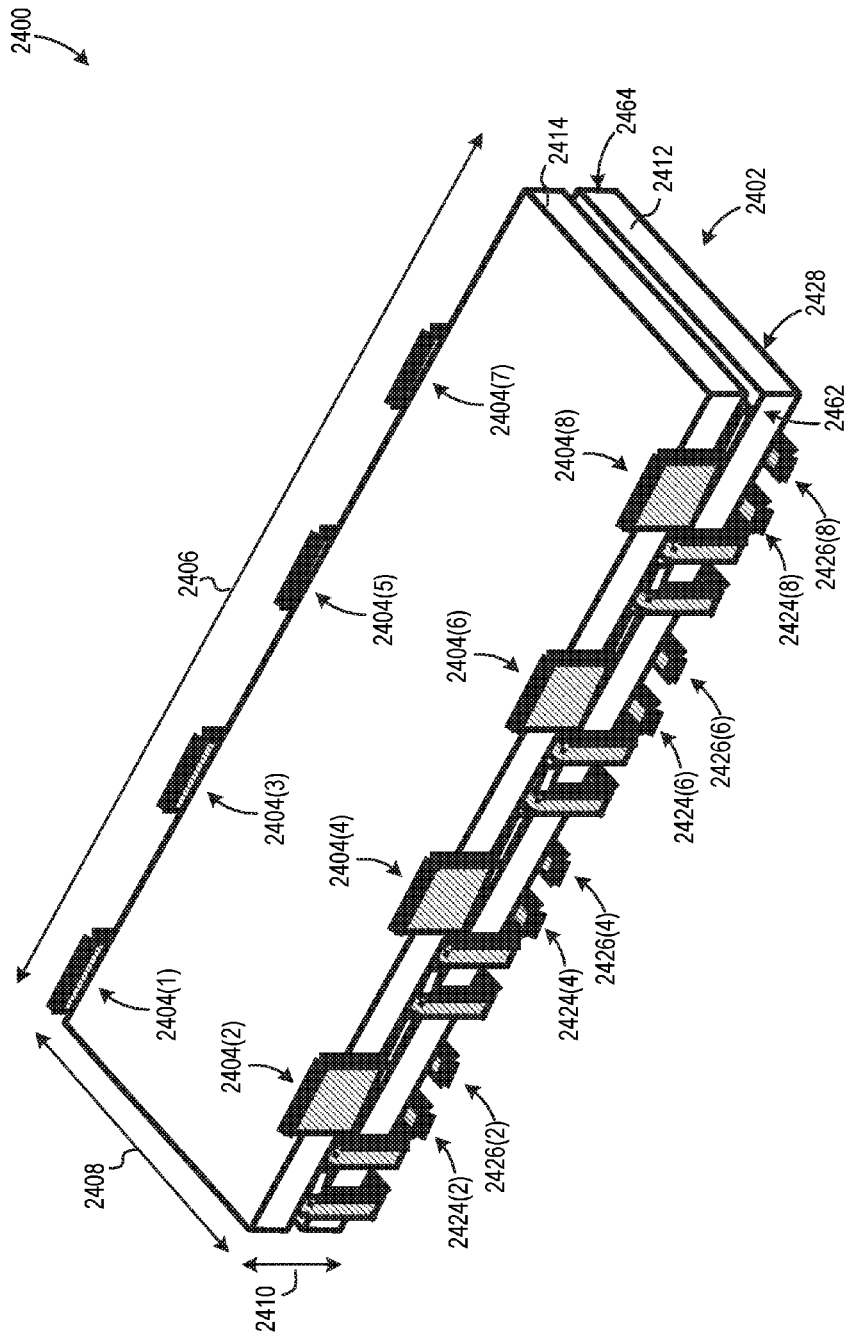

FIG. 24

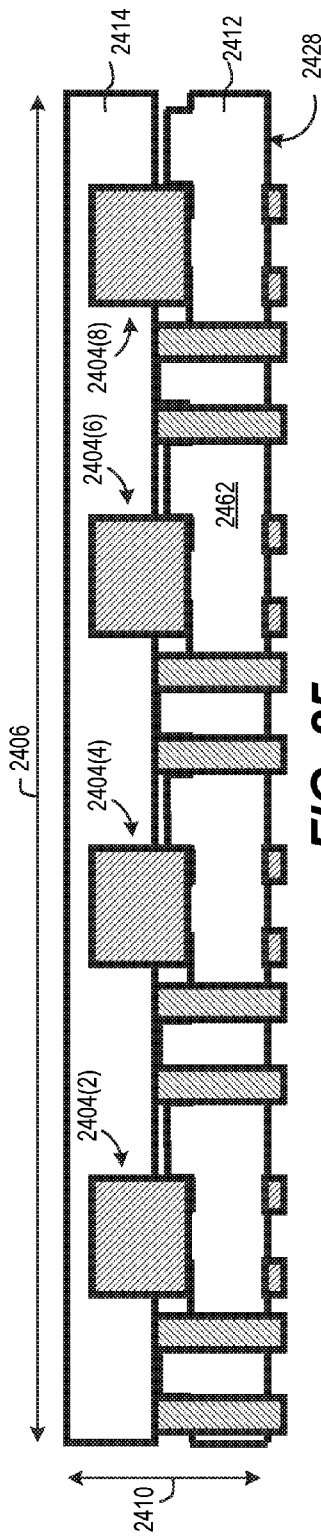

FIG. 25

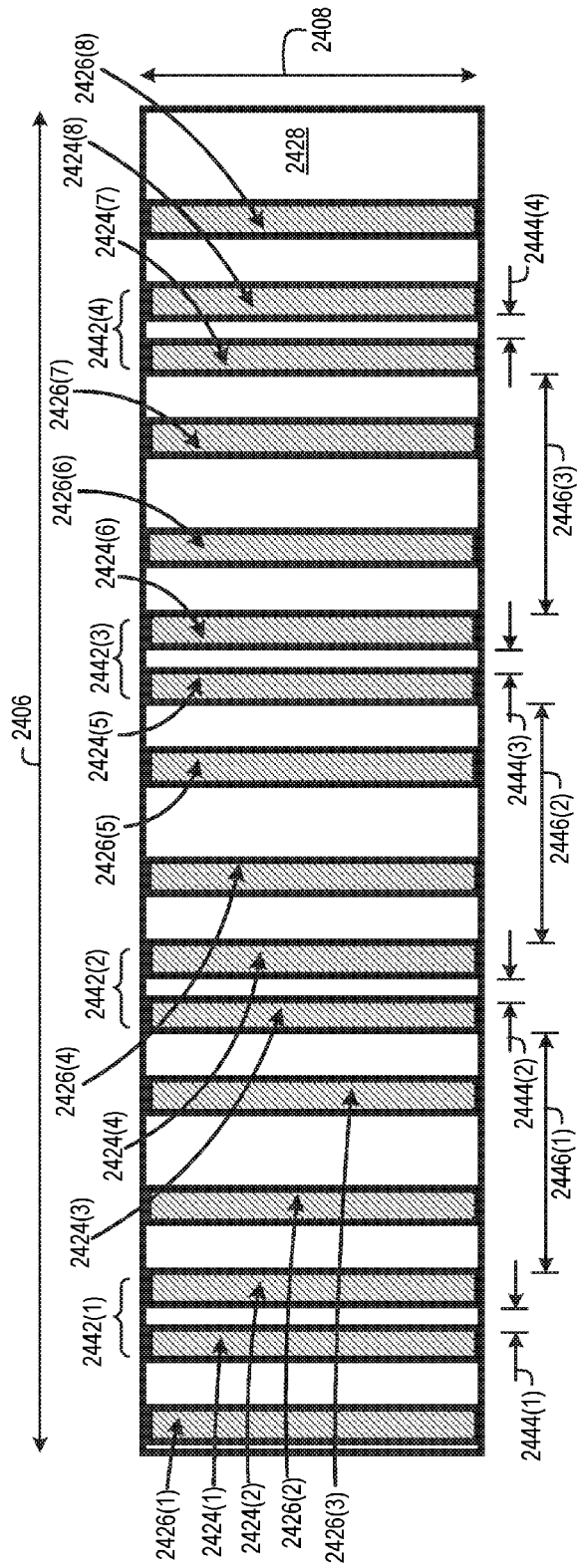

FIG. 26

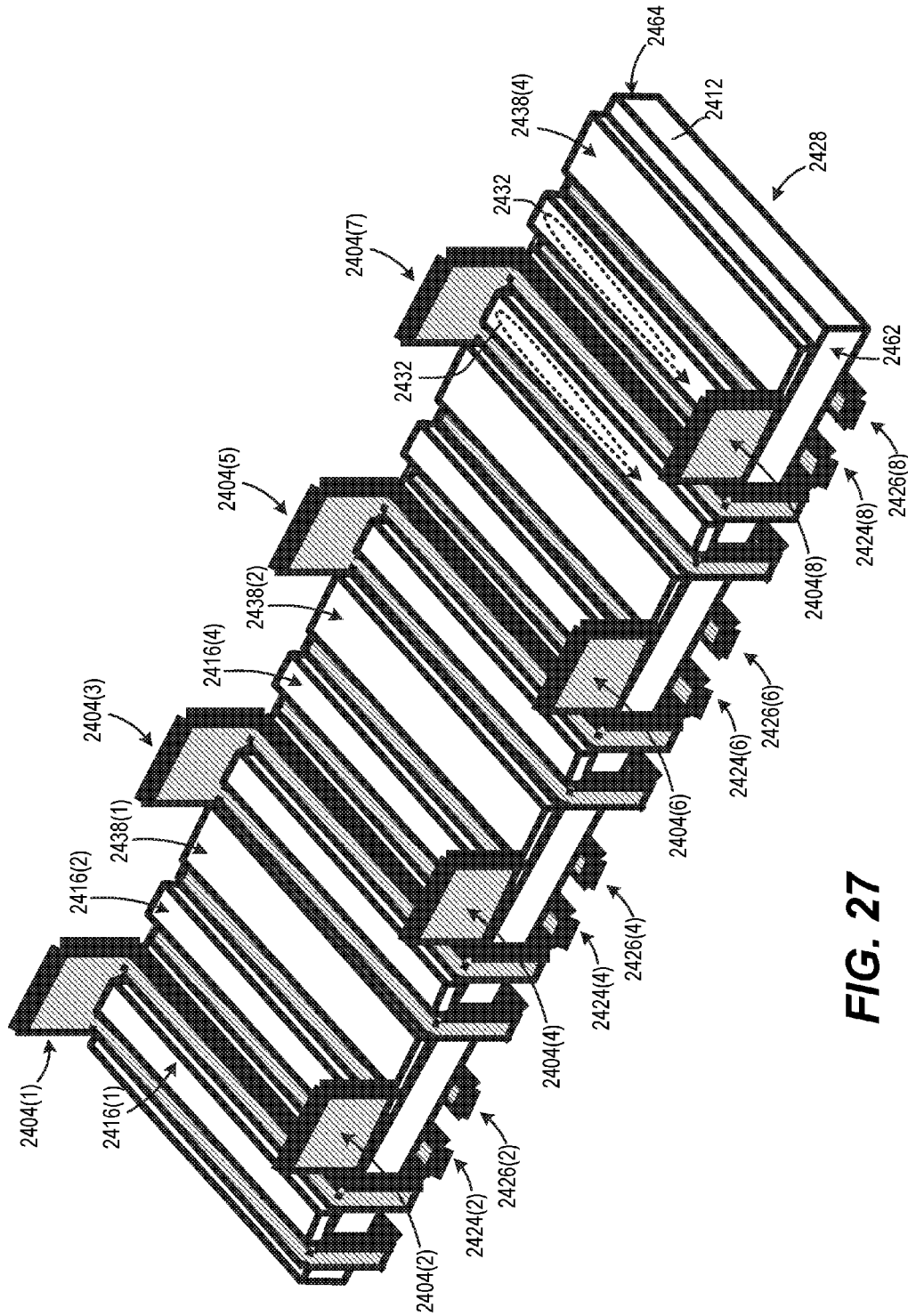

FIG. 27

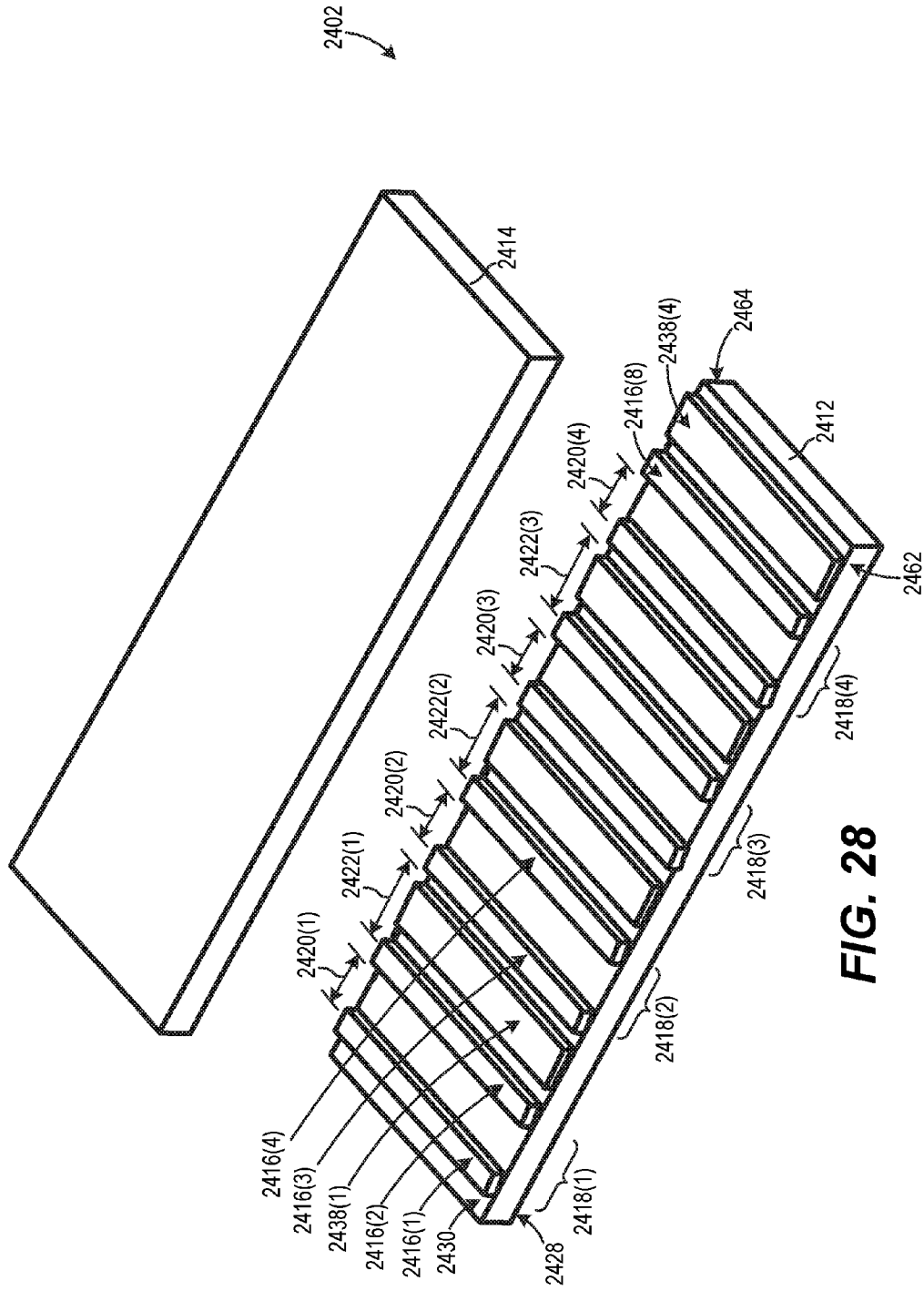

FIG. 28

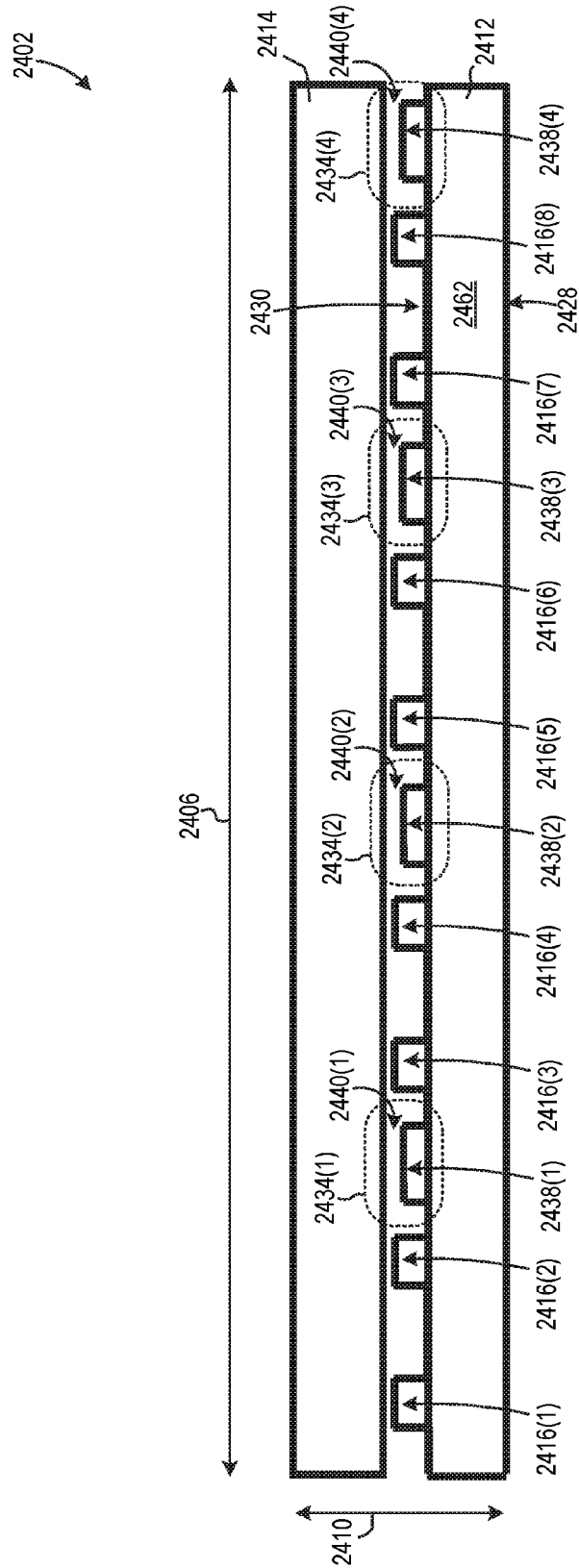

FIG. 29

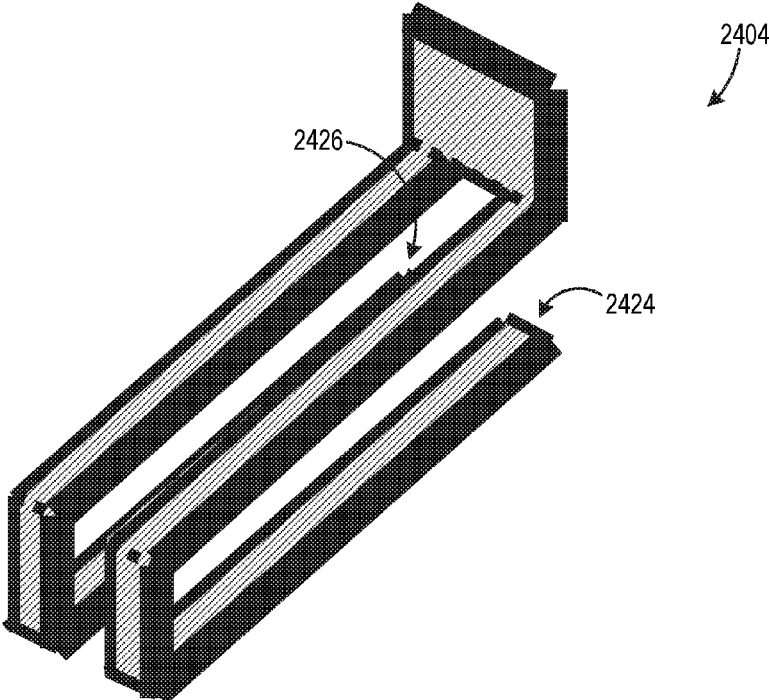

FIG. 30

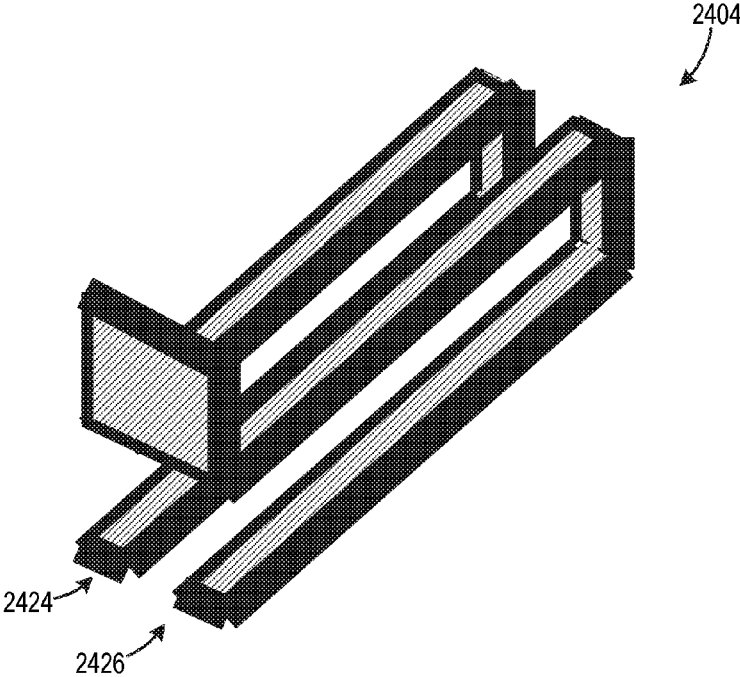

FIG. 31

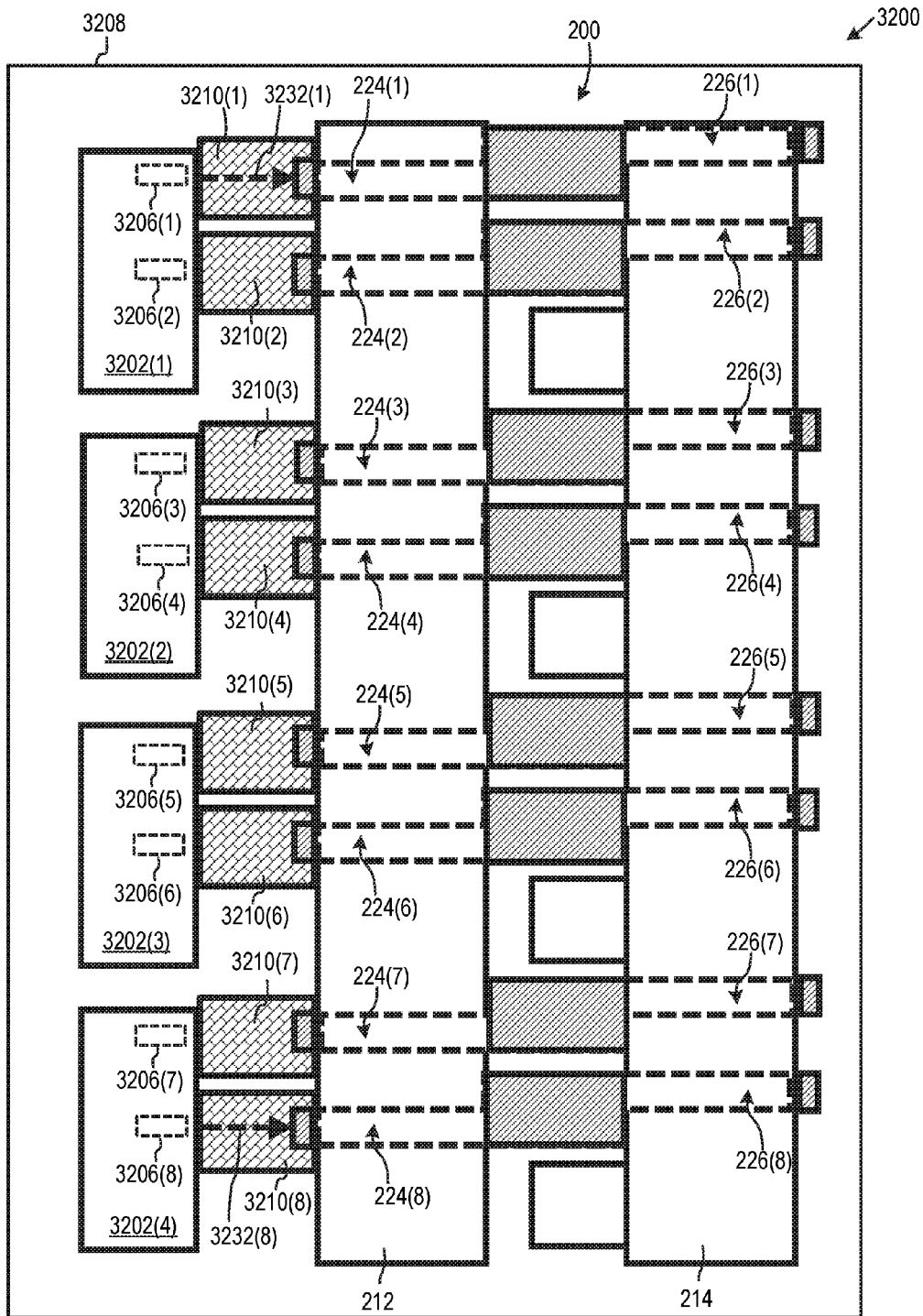

FIG. 32

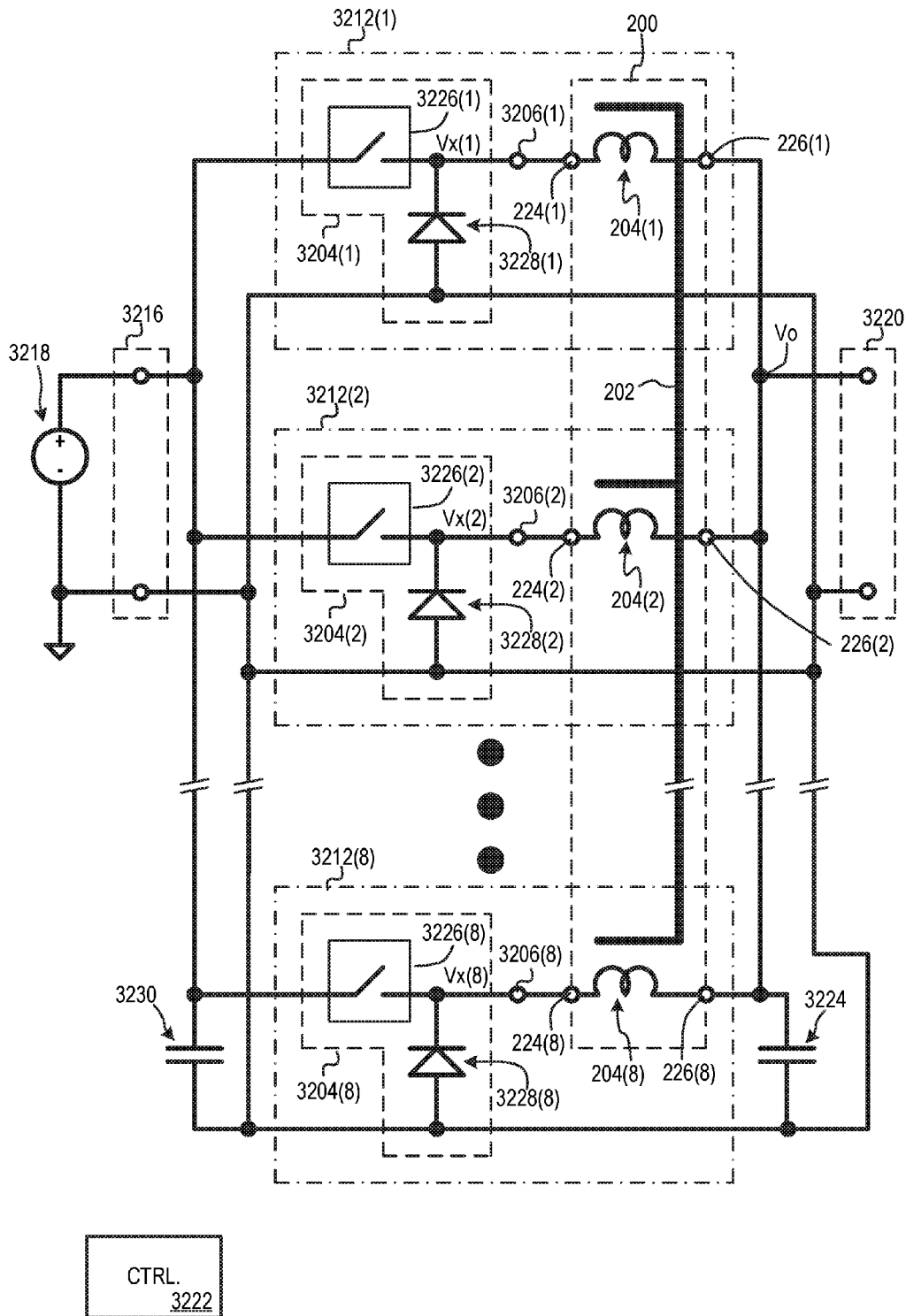

FIG. 33

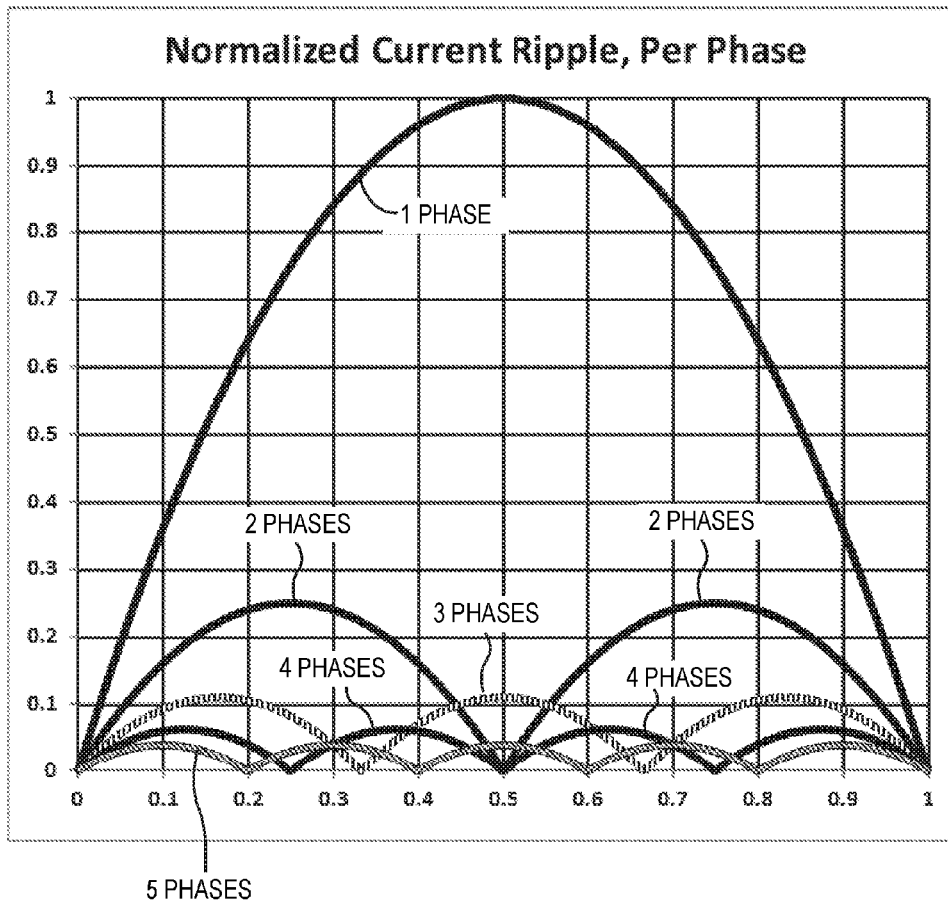

FIG. 34

1

COUPLED INDUCTORS WITH NON-UNIFORM WINDING TERMINAL DISTRIBUTIONS

RELATED APPLICATIONS

This application is a divisional of U.S. patent application Ser. No. 13/802,363, filed Mar. 13, 2013, which is incorporated herein by reference.

BACKGROUND

It is known to electrically couple multiple switching sub-converters in parallel to increase switching power converter capacity and/or to improve switching power converter performance. One type of switching power converter with multiple switching sub-converters is a “multi-phase” switching power converter, where the sub-converters, which are often referred to as “phases,” switch out-of-phase with respect to each other. Such out-of-phase switching results in ripple current cancellation at the converter output filter and allows the multi-phase converter to have a better transient response than an otherwise similar single-phase converter.

As taught in U.S. Pat. No. 6,362,986 to Schultz et al., which is incorporated herein by reference, a multi-phase switching power converter’s performance can be improved by magnetically coupling the energy storage inductors of two or more phases. Such magnetic coupling results in ripple current cancellation in the inductors and increases ripple switching frequency, thereby improving converter transient response, reducing input and output filtering requirements, and/or improving converter efficiency, relative to an otherwise identical converter without magnetically coupled inductors.

Two or more magnetically coupled inductors are often collectively referred to as a “coupled inductor” and have associated leakage inductance and magnetizing inductance values. Magnetizing inductance is associated with magnetic coupling between windings; thus, the larger the magnetizing inductance, the stronger the magnetic coupling between windings. Leakage inductance, on the other hand, is associated with energy storage. Thus, the larger the leakage inductance, the more energy stored in the inductor. Leakage inductance results from leakage magnetic flux, which is magnetic flux generated by current flowing through one winding of the inductor that is not coupled to the other windings of the inductor.

Integrated circuits including two or more power stages have been developed for use in switching power converters. For example, FIG. 1 shows a top plan view of a prior art four-phase buck switching power converter **100** including two integrated circuits **102** and a coupled inductor **104**. In this document, specific instances of an item may be referred to by use of a numeral in parentheses (e.g., integrated circuit **102(1)**) while numerals without parentheses refer to any such item (e.g., integrated circuits **102**). Coupled inductor **104** includes four windings **106**, and opposing ends of each winding form respective first and second solder tabs **108**, **110**. Solder tabs **108**, **110** are uniformly distributed along a length **112** of coupled inductor **104**.

Each integrated circuit **102** includes two buck power stages (not shown) and two terminal sets **114**. Each terminal set **114** include one or more electrical terminals, such as one or more solder balls, electrically coupled to a common node and disposed on a bottom outer surface of integrated circuit **102**. Terminal sets **114** are symbolically indicated by dashed line in the FIG. 1 top plan view because the terminal sets are

2

not visible when looking at the tops of integrated circuits **102**. Each terminal set **114** provides electrical interface to a respective power stage of the integrated circuit. Both power stages and associated terminal sets **114** are located in the same portion of the integrated circuit, to ease integrated circuit design and construction. Thus, terminal sets **114** are located close together on integrated circuit **102**.

Each terminal set **114** is electrically coupled to a respective first solder tab **108** by a conductor (not shown), such as a printed circuit board (PCB) conductive “trace.” Each power stage and its respective winding **106** form part of a phase of buck switching converter **100**. Accordingly, each integrated circuit **102** supports a respective pair of converter **100** phases, and coupled inductor **104** supports all four phases of converter **100**.

SUMMARY

In an embodiment, a coupled inductor includes a ladder magnetic core having a length, a width, and a height. The ladder magnetic core includes two rails extending in the lengthwise direction and joined in the widthwise direction by at least first, second, third, and fourth rungs sequentially disposed along the length of the magnetic core. The coupled inductor further includes first, second, third, and fourth windings wound at least partially around the first, second, third, and fourth rungs, respectively. The second rung is substantially closer in the lengthwise direction to the first rung than to the third rung, and the third rung is substantially closer in the lengthwise direction to the fourth rung than to the second rung.

In an embodiment, a coupled inductor includes a ladder magnetic core, a first winding, and a second winding. The ladder magnetic core has a length, a width, and a height. The ladder magnetic core includes first and second rails extending in the lengthwise direction and joined in the widthwise direction by at least first and second rungs. The first winding is wound, in a first orientation, at least partially around the first rung, and the second winding is wound, in a second orientation, at least partially around the second rung. The second orientation is opposite to the first orientation. Opposing ends of the first winding form first and second solder tabs, respectively, and opposing ends of the second winding form third and fourth solder tabs, respectively. The first and third solder tabs are disposed at least partially on a bottom outer surface of the first rail, and the second and fourth solder tabs are disposed at least partially on a bottom outer surface of the second rail. The first and second windings are arranged such that current flowing into the first and third solder tabs flows in a common direction around each of the first and second rungs, respectively, when seen looking cross-sectionally in the widthwise direction of the magnetic core.

In an embodiment, a coupled inductor includes a ladder magnetic core, a first winding, a second winding, and a third winding. The ladder magnetic core has a length, a width, and a height. The ladder magnetic core includes two rails joined in the heightwise direction by at least first, second, and third rungs respectively disposed along the length of the magnetic core. The first winding is wound, in a first orientation, at least partially around the first rung. The second winding is wound, in a second orientation opposite to the first orientation, at least partially around the second rung. The third winding is wound, in the first orientation, at least partially around the third rung. The second rung is substantially closer in the lengthwise direction to the first rung than to the third rung.

In an embodiment, a coupled inductor includes a ladder magnetic core including two opposing rails extending in a lengthwise direction and joined by a plurality of rungs. The coupled inductor further includes a respective winding wound around each of the plurality of rungs. The plurality of rungs are divided into at least two groups of rungs, and a lengthwise separation distance between adjacent rungs in each group of rungs is less than a lengthwise separation distance between adjacent rungs of different groups of the at least two groups.

In an embodiment, a multi-phase switching power converter includes a coupled inductor including a ladder magnetic core having a length, a width, and a height. The ladder magnetic core includes two rails extending in the lengthwise direction and joined in the widthwise direction by at least first, second, third, and fourth rungs sequentially disposed along the length of the magnetic core. The coupled inductor further includes first, second, third, and fourth windings wound at least partially around the first, second, third, and fourth rungs, respectively. The second rung is substantially closer in the lengthwise direction to the first rung than to the third rung, and the third rung is substantially closer in the lengthwise direction to the fourth rung than to the second rung. The multi-phase switching power converter further includes first, second, third, and fourth switching circuits. Each switching circuit is adapted to repeatedly switch an end of a respective one of the first, second, third, and fourth windings between at least two different voltage levels.

In an embodiment, a multi-phase switching power converter includes a coupled inductor including a ladder magnetic core, a first winding, and a second winding. The ladder magnetic core has a length, a width, and a height. The ladder magnetic core includes first and second rails extending in the lengthwise direction and joined in the widthwise direction by at least first and second rungs. The first winding is wound, in a first orientation, at least partially around the first rung, and the second winding is wound, in a second orientation, at least partially around the second rung. The second orientation is opposite to the first orientation. Opposing ends of the first winding form first and second solder tabs, respectively, and opposing ends of the second winding form third and fourth solder tabs, respectively. The first and third solder tabs are disposed at least partially on a bottom outer surface of the first rail, and the second and fourth solder tabs are disposed at least partially on a bottom outer surface of the second rail. The first and second windings are arranged such that current flowing into the first and third solder tabs flows in a common direction around each of the first and second rungs, respectively, when seen looking cross-sectionally in the widthwise direction of the magnetic core. The multi-phase switching power converter further includes first and second switching circuits. The first switching circuit is adapted to repeatedly switch the first solder tab between at least two different voltage levels, and the second switching circuit is adapted to repeatedly switch the third solder tab between at least two different voltage levels.

In an embodiment, a multi-phase switching power converter includes a coupled inductor, including a ladder magnetic core and first, second, and third windings. The ladder magnetic core has a length, a width, and a height. The ladder magnetic core includes two rails joined in the heightwise direction by at least first, second, and third rungs respectively disposed along the length of the magnetic core. The first winding is wound, in a first orientation, at least partially around the first rung. The second winding is wound, in a second orientation opposite to the first orientation, at least partially around the second rung. The third winding is

wound, in the first orientation, at least partially around the third rung. The second rung is substantially closer in the lengthwise direction to the first rung than to the third rung. The multi-phase switching power converter further includes first, second, and third switching circuits. Each switching circuit is adapted to repeatedly switch an end of a respective one of the first, second, and third windings between at least two different voltage levels.

BRIEF DESCRIPTION OF THE DRAWINGS

FIG. 1 shows a top plan view of a prior art four-phase buck switching power converter including two integrated circuits and a coupled inductor.

FIG. 2 shows a perspective view of a coupled inductor having a non-uniform winding terminal distribution, according to an embodiment.

FIG. 3 shows a top plan view of the FIG. 2 coupled inductor.

FIG. 4 shows a cross-sectional view of the FIG. 2 coupled inductor.

FIG. 5 shows a top plan view of a magnetic core of the FIG. 2 coupled inductor.

FIG. 6 shows a perspective view of the FIG. 2 coupled inductor with a rail of the magnetic core shown in outline form.

FIG. 7 shows a perspective view of a winding of the FIG. 2 coupled inductor.

FIG. 8 shows a perspective view of a winding of certain alternate embodiments of the FIG. 2 coupled inductor.

FIG. 9 shows a perspective view of another coupled inductor having a non-uniform winding terminal distribution, according to an embodiment.

FIG. 10 shows a top plan view of the FIG. 9 coupled inductor.

FIG. 11 shows a right side elevational view of the FIG. 9 coupled inductor.

FIG. 12 shows a bottom plan view of the FIG. 9 coupled inductor.

FIG. 13 shows a cross-sectional view of the FIG. 9 coupled inductor.

FIG. 14 shows a perspective view of the FIG. 9 coupled inductor with a first rail and a leakage element of the inductor's magnetic core shown in outline form.

FIG. 15 shows a perspective view of a winding of the FIG. 9 coupled inductor at zero degree orientation, and FIG. 16 shows a perspective view of a winding of the FIG. 9 coupled inductor at 180 degree orientation.

FIG. 17 shows one possible PCB footprint for use with the FIG. 9 coupled inductor, according to an embodiment.

FIG. 18 shows one possible PCB footprint for use with the coupled inductor of the switching power converter of FIG. 1.

FIG. 19 shows a perspective of view of an alternative winding at zero degree orientation, and FIG. 20 shows a perspective view of the alternative winding at 180 degree orientation.

FIG. 21 shows one possible PCB footprint for use with the FIG. 9 coupled inductor and the windings of FIGS. 19 and 20, according to an embodiment.

FIG. 22 shows a perspective of a winding used in certain other alternate embodiments of the FIG. 9 coupled inductor.

FIG. 23 shows a cross-sectional view of a winding wound around a rung, to illustrate optimization of rung and winding geometry for minimum direct current winding resistance.

FIG. 24 shows a perspective view of yet another coupled inductor having a non-uniform winding terminal distribution, according to an embodiment.

FIG. 25 shows a front elevational view of the FIG. 24 coupled inductor.

FIG. 26 shows a bottom plan view of the FIG. 24 coupled inductor.

FIG. 27 shows a perspective view of the FIG. 24 coupled inductor with a portion of the magnetic core removed.

FIG. 28 shows an exploded perspective view of the magnetic core of the FIG. 24 coupled inductor.

FIG. 29 shows a front elevational view of the magnetic core of the FIG. 24 coupled inductor.

FIG. 30 shows a perspective view of a winding of the FIG. 24 coupled inductor at zero degree orientation, and FIG. 31 shows a perspective view of a winding of the FIG. 24 coupled inductor at 180 degree orientation.

FIG. 32 shows a top plan view of part of an eight-phase buck switching power converter including the coupled inductor of FIG. 2 electrically coupled to four integrated circuits, according to an embodiment.

FIG. 33 is an electrical schematic of the FIG. 32 switching power converter.

FIG. 34 shows an idealized graph of normalized ripple current per phase versus duty cycle, for different numbers of magnetically coupled phases, in a buck switching power converter of an arbitrary number of phases.

DETAILED DESCRIPTION OF THE EMBODIMENTS

While there are significant benefits to pairing coupled inductors with integrated power stages, Applicant has discovered that there are also drawbacks. For example, consider again multi-phase switching power converter 100 of FIG. 1. A pitch 118 between integrated circuit terminal sets 114 is significantly smaller than a pitch 120 between solder tabs 108. This pitch discrepancy makes it impossible to align every terminal set 114 with a respective solder tab 108. Misalignment of terminal sets 114 and solder tabs 108 results in long length and associated high impedance of some conductors between terminal sets 114 and solder tabs 108. Additionally, converter 100 typically includes additional components 124, such as resistors and capacitors, which support integrated circuits 102. Additional components 124 may further impede alignment of terminal sets 114 and solder tabs 108 by constraining placement of integrated circuits 102 and associated conductor routing.

Each terminal set 114 is separated from its respective solder tab by a separation distance 122. Separation distances 122(1), 122(3) are relatively short because terminal sets 114(1), 114(3) are aligned with solder tabs 108(1), 108(3). In contrast, separation distances 122(2), 122(4) are relatively long because terminal sets 114(2), 114(4) are not aligned with solder tabs 108(2), 108(4). Conductors spanning separation distances 122(2), 122(4) will therefore be long and have relatively high impedances.

High conductor impedance is undesirable, for example, because it causes significant conduction losses at high current levels, thereby impairing converter efficiency and causing undesired converter heating. Additionally, long conductors may cause electromagnetic interference with nearby circuitry, when high slew rate current flows through the conductors. Conductor impedance may be particularly significant when the conductors are PCB traces, because PCB traces are normally formed of thin metallic foil having

relatively high impedance, as compared to relatively thick metallic solder tabs 108 and associated windings 106.

Accordingly, Applicant has developed coupled inductors with non-uniform winding terminal distributions, which facilitate aligning the winding terminals with integrated circuit terminals. As discussed below, use of these coupled inductors, instead of conventional coupled inductors, may at least partially overcome one or more of the problems discussed above.

FIG. 2 shows a perspective view of a coupled inductor 200 having a non-uniform winding terminal distribution. Coupled inductor 200 includes a ladder magnetic core 202 and N windings 204. Although N is shown as being equal to eight, N could alternately be any integer greater than three. Magnetic core 202 has a length 206, a width 208, and a height 210. FIG. 3 shows a top plan view of coupled inductor 200, with the outlines of windings 204 shown by dashed lines where obscured by core 202. FIG. 4 shows a cross-sectional view of coupled inductor 200 taken along line A-A of FIG. 3, and FIG. 5 shows a top plan view of magnetic core 202. In this document, not all instances of every element are labeled in the figures to promote illustrative clarity. For example, only some instances of windings 204 are labeled in FIG. 3.

Magnetic core 202 is formed of a magnetic material, such as a ferrite material or a powdered iron material. Magnetic core 202 includes first and second rails 212, 214 extending in the lengthwise 206 direction and separated in the widthwise 208 direction. Magnetic core 210 further includes N rungs 216, where each rung 216 joins first and second rails 212, 214 in the widthwise 208 direction, as shown in FIG. 5. FIG. 6 shows a perspective view of coupled inductor 200 with first rail 212 shown in outline form, to show the interior of coupled inductor 200. Although rails 212, 214 and rungs 216 are shown as discrete magnetic elements, two or more of these magnetic elements may be combined without departing from the scope hereof. Furthermore, in some embodiments, magnetic core 202 is a single-piece magnetic core that is formed, for example, by molding magnetic material in a ladder shape.

Rungs 216 are divided into at least two separate groups 218, where each group 218 includes two or more of the N rungs 216, as shown in FIG. 5. Adjacent rungs 216 within a common group 218 are separated by a lengthwise separation distance 220. For instance, rungs 216(1) and 216(2) of group 218(1) are separated by a separation distance 220(1), and rungs 216(3) and 216(4) of group 218(2) are separated by a separation distance 220(2). Adjacent rungs 216 of different groups 218, in contrast, are separated by a lengthwise separation distance 222. For instance, rungs 216(2) and 216(3) are separated by a separation distance 222(1), and rungs 216(4) and 216(5) are separated by a separation distance 222(2). Each separation distance 220 is smaller than each separation distance 222, so that adjacent rungs within groups 218 are substantially closer together than adjacent rungs of different groups 218. For example, rung 216(2) is substantially closer, in the lengthwise 206 direction, to rung 216(1) than to rung 216(3). As another example, rung 216(3) is substantially closer, in the lengthwise direction, to rung 216(4) than to rung 216(2).

Opposing ends of each winding 204 form respective solder tabs 224, 226, as shown, for example, in FIG. 3. Solder tabs 224, 226 serve as terminals for winding 204. Solder tabs 224, 226 are disposed at least partially on bottom outer surfaces 228, 230 of first and second rails 212, 214, respectively. However, in some alternate embodiments, one or more of solder tabs 224, 226 are replaced with a different

terminal type, such as a through-hole pin or a socket pin. FIG. 7 shows a perspective view of one winding 204 instance.

Each winding 204 is wound around a respective rung 216 such that current flowing into each winding's first solder tab 224 flows around the winding's respective rung 216 in a common direction, as seen when looking cross-sectionally in the widthwise 208 direction. For example, current flowing into each winding's first solder tab 224 flows around the winding's respective rung 216 in a counterclockwise direction 232, as seen when looking cross-sectionally from first rail 212 towards second rail 214, as shown in FIG. 6. This winding configuration causes coupled inductor 200 to have inverse magnetic coupling, when either all first solder tabs 224 or all second solder tabs 226 are connected to respective switching nodes. Inverse magnetic coupling is required to achieve advantages associated with using coupled inductors, instead of discrete inductors, in switching power converter applications.

Spaces 234 within ladder magnetic core 202, but outside of groups 218, provide leakage magnetic flux paths, thereby contributing to leakage inductance of windings 204 (see FIG. 3). For example, dashed line 236 symbolically illustrates how space 234(1) provides a leakage magnetic flux path for winding 204(2), although space 234(1) also provides leakage magnetic flux paths for other windings 204. The fact that spaces 234 are within magnetic core 202 helps contain leakage magnetic flux within coupled inductor 200, thereby helping minimize the likelihood of electromagnetic interference from leakage magnetic flux. Although not required, magnetic core 202 typically further includes N leakage elements or "teeth" 238, where each tooth 238 at least partially bridges a widthwise 208 separation distance between first and second rails 212, 214. Leakage teeth 238 and rung groups 218 are disposed in an alternating manner along length 206, as shown in FIG. 5. Such leakage tooth 238 distribution helps achieve short paths for leakage fluxes from multiple windings, which minimizes core losses.

Leakage teeth 238 decrease the leakage magnetic flux path reluctance in spaces 234, thereby promoting high and controllable leakage inductance values. Each leakage tooth 238 is typically separated from first rail 212 by a gap 240. Gaps 240 help prevent magnetic saturation at high current levels, and gap 240 dimensions can be adjusted during coupled inductor design to tune leakage inductance values. For example, leakage inductance can be increased by decreasing a thickness of gaps 240 in the widthwise 208 direction. Additionally, winding 204 leakage inductance values can be adjusted during inductor 200 design by varying the configuration, such as the size and/or composition, of leakage teeth 238.

In some alternate embodiments, such as where leakage teeth 238 are formed of a magnetic material with a distributed air gap, leakage teeth 238 completely bridge the widthwise separation distance between first and second rails 212, 214. Additionally, leakage teeth 238 could alternately extend from first rail 212 toward second rail 214, such that gaps 240 separate leakage teeth 238 from second rail 214. Furthermore, each leakage tooth 238 could be split into first and second sub-teeth (not shown) extending into space 234 from rails 212 and 214, respectively, such that a gap separates the sub-teeth in the widthwise 208 direction.

The non-uniform rung 216 distribution along length 206 causes solder tabs 224, 226 to be non-uniformly distributed along length 206. Solder tabs 224 are divided into different groups 242 of two or more solder tabs 224, as shown in FIGS. 2 and 3. Lengthwise separation distances 244 between

adjacent solder tabs 224 within each group 242 are smaller than lengthwise separation distances 246 between adjacent solder tabs 224 of different groups. For example, solder tab 224(2) is substantially closer in the lengthwise 206 direction to solder tabs 224(1) than to solder tab 224(3), and solder tab 224(3) is substantially closer in the lengthwise 206 direction to solder tab 224(4) than to solder tab 224(2). Such non-uniform solder tab distribution may facilitate aligning the solder tabs with an integrated circuit's terminals, such as discussed below with respect to FIG. 32.

The configuration of magnetic core 202 enables the majority of inductor volume to be occupied by magnetic elements, namely rails 212, 214, rungs 216, and leakage teeth 238, thereby promoting large magnetic core cross-sectional area per unit volume. Large magnetic core cross-sectional area promotes low core losses in magnetic core 202.

Although coupled inductor 200 is shown with two rungs 216 per rung group 218, the number of rungs 216 per group 218 could be increased. For example, in certain alternate embodiments, N is equal to nine, and the nine rungs 216 are divided into three groups 218, where each group includes three rungs. Furthermore, although windings 204 are shown as being single-turn foil windings, windings 204 could be modified, as long as first solder tabs 224, or analogous terminals such as through-hole pins, are non-uniformly distributed along length 206. For example, in some alternate embodiments, windings 204 are multi-turn windings, which promote large inductance values with small core losses. For example, FIG. 8 shows a perspective view of a two-turn wire winding 804, which is used in place of single-turn foil windings 204 in some alternate embodiments of coupled inductor 200. Opposing ends of winding 804 are, for example, coupled to terminals (not shown), such as solder tabs or through-hole pins. Moreover, some alternate embodiments include two or more separate windings wound at least partially around each rung 216. The separate windings of each rung 216 are connected, for example, by external conductors, such as PCB traces, to form a multi-turn winding, such as using techniques similar to those taught in U.S. Pat. No. 7,994,888 to Ikriannikov, which is incorporated by reference.

Multiple instances of coupled inductor 200 could be joined. For example, two instances of coupled inductor 200 could be joined in the lengthwise 206 direction to form a coupled inductor including sixteen windings 204.

FIG. 9 shows a perspective view of another coupled inductor 900 having a non-uniform winding terminal distribution. Coupled inductor 900 includes a ladder magnetic core 902 and N windings 904. Although coupled inductor 900 is shown with N being equal to eight, N could alternately be any integer greater than one without departing from the scope hereof.

Magnetic core 902 has a length 906, a width 908, and a height 910. FIG. 10 shows a top plan view of coupled inductor 900, where the outlines of windings 904 are shown by dashed lines where obscured by magnetic core 902. FIG. 11 shows a right side elevational view, FIG. 12 shows a bottom plan view, and FIG. 13 shows a cross-sectional view taken along line A-A of FIG. 10.

Magnetic core 902 is formed of a magnetic material, such as a ferrite material or a powdered iron material. Magnetic core 902 includes first and second rails 912, 914 extending in the lengthwise 906 direction and joined by N rungs 916, in a manner similar to magnetic core 202 of coupled inductor 200. Magnetic core 902 further includes a leakage tooth 938 bridging a widthwise 908 separation distance between rails

912, 914. FIG. 14 shows a perspective view of coupled inductor **900** with first rail **912** and leakage tooth **938** shown in outline form, to show the inductor's interior.

Leakage tooth **938** is disposed over rungs **916** in the heightwise **910** direction, and a gap **940** typically separates leakage tooth **938** from second rail **914**. However, in some alternate embodiments, such as where leakage tooth **938** is formed of a distributed air gap magnetic material, leakage tooth **938** completely bridges the widthwise separation distance between first and second rails **912, 914**. Additionally, magnetic core **902** could be modified such that leakage tooth **938** extends from second rail **914** towards first rail **912**, such that tooth **938** is separated from rail **912** by gap **940**. Furthermore, leakage tooth **938** could be split into first and second sub-teeth (not shown) extending towards each other from rails **912** and **914**, respectively, such that a gap separates the sub-teeth in the widthwise **908** direction. Moreover, although leakage tooth **938** is shown as extending along the entire length **906** to promote substantially equal leakage inductance values among windings **904**, in some alternate embodiments, leakage tooth **938** only extends along part of length **906**. Although rails **912, 914**, rungs **916**, and leakage tooth **938** are shown as being discrete magnetic elements, two or more of these magnetic elements may be combined without departing from the scope hereof. Furthermore, in some embodiments, magnetic core **908** is a single-piece magnetic core.

Leakage tooth **938** provides a leakage magnetic flux path and therefore contributes to winding **904** leakage inductance. Leakage tooth **938** also electrically shields the top of windings **904**. Leakage inductance values of windings **904** can be adjusted during inductor **900** design by varying the configuration, such as the size and/or composition, of leakage tooth **938**, or by varying the widthwise **908** thickness of gap **940**.

Opposing ends of each winding **904** form respective solder tabs **924, 926**, which are structurally capable of surface mount soldering to a common substrate, such as a PCB. See, for example, FIG. 10. Solder tabs **924, 926** of each winding **904** serve as terminals for the winding, although in some alternate embodiments, one or more of solder tabs **924, 926** are replaced with a different connector type, such as a through-hole pin or a socket pin. Solder tabs **924** are disposed on a bottom outer surface **928** of first rail **912**, and solder tabs **926** are disposed on a bottom outer surface **930** of second rail **914**. Solder tabs **924** and **926** of a given winding **904** are separated by a lengthwise separation distance **948**.

Each winding **904** typically has a common geometric shape, as shown, to promote ease of winding procurement and manufacturing simplicity. However, windings **904** are wound around respective rungs **916** with alternating opposing orientations, such that windings **904(1), 904(3), 904(5), and 904(7)** have a zero degree orientation, while windings **904(2), 904(4), 904(6), and 904(8)** have a 180 degree orientation. Zero degree orientation is characterized by solder tab **924** being disposed at least partially on first rail bottom outer surface **928**, and solder tab **926** being disposed at least partially on second rail bottom outer surface **930**. 180 degree orientation is characterized by solder tab **924** being disposed at least partially on second rail bottom outer surface **930**, and solder tab **926** being disposed at least partially on first rail bottom outer surface **928**. Thus, windings **904** having a 180 degree orientation are the mirror image of windings **904** having a zero degree orientation, as seen when looking in the heightwise direction. FIG. 15 shows a perspective view of a winding **904** instance at zero

degree orientation, and FIG. 16 shows a perspective view of a winding **904** instance at 180 degree orientation, as seen when looking from first rail **912** towards second rail **914**.

Although windings **904** have alternating opposing orientations, the windings are wound such that current flowing into each winding's terminal at first rail **912** flows around the winding's respective rung **916** in a common direction, as seen when looking cross-sectionally in the widthwise **908** direction. For example, current flowing into solder tab **924(1)** of winding **904(1)** flows in a counter-clockwise direction **932** around rung **916(1)**, and current flowing into solder tab **926(2)** of winding **904(2)** flows in a counter-clockwise direction **932** around rung **916(2)**, as seen when looking cross-sectionally from first rail **912** towards second rail **914** (see FIG. 14). This winding configuration causes coupled inductor **900** to have inverse magnetic coupling, when all terminals along first rail **912** are electrically coupled to a respective switching node.

Lengthwise separation distance **948** is typically minimized so that when windings **904** are wound around rungs **916** in alternating opposing orientations, solder tabs **924, 926** of adjacent windings are grouped in pairs along first rail bottom outer surface **928**. For example, in some embodiments, separation distance **948** is fifty percent or less of a rung length **950** (see, e.g., FIGS. 14-16). The solder tabs **924, 926** on first rail bottom outer surface **928** are divided into different groups **942**, where each group includes two solder tabs, as shown in FIG. 10. Lengthwise separation distances **944** between adjacent solder tabs **924, 926** within each group **942** are smaller than lengthwise separation distances **946** between adjacent solder tabs of different groups. Such non-uniform solder tab distribution may facilitate aligning the solder tabs with an integrated circuit's terminals, such as discussed below with respect to FIG. 32. FIG. 17 shows a top plan view of one possible PCB footprint **1700** for use with coupled inductor **900**. As shown, separation distances **1752** between adjacent winding terminal pads within each group **1754** of winding terminal pads are relatively small. In contrast, FIG. 18 shows a top plan view of one possible PCB footprint **1800** for use with coupled inductor **104** of FIG. 1. As can be seen, separation distances **1852** between adjacent winding terminal pads are relatively large.

FIG. 19 shows a perspective view of a winding **1904**. Winding **1904** is similar to winding **904**, but winding **1904** includes asymmetrical solder tabs **1924, 1926**, such that solder tab **1926** is larger than solder tab **1924**. Windings **1904** are used in place of windings **904** in some alternate embodiments of coupled inductor **900**. The asymmetrical solder tabs of winding **1904** helps maximize copper cross section area, while minimizing solder tab separation, when windings **1904** are disposed in alternating opposing orientations along length **906**. Large solder tabs help to minimize conduction losses when the solder tabs supplement PCB traces. FIG. 19 shows winding **1904** at zero degree orientation, and FIG. 20 shows winding **1904** at 180 degree orientation, as seen when looking from first rail **912** toward second rail **914**. FIG. 21 shows a top plan view of one possible PCB footprint **2100** for use with coupled inductor **900** including windings **1904** in place of windings **904**. As shown, separation distances **2152** between winding terminal pads are similar to separation distances **1752** of the FIG. 17 footprint, even though a larger portion of the PCB surface area is covered by solder tabs in the FIG. 21 footprint than in the FIG. 17 footprint.

Although coupled inductor **900** is discussed above with respect to single-turn foil windings **904** or **1904**, coupled

inductor **900** could alternately include multi-turn windings, which promote large inductance values with small core losses. For example, FIG. 22 shows a perspective view of a two-turn wire winding **2204**, which is used in place of single-turn foil windings **904**, in some alternate embodiments of coupled inductor **900**. Moreover, some alternate embodiments include two or more separate windings wound at least partially around each rung **916**. The windings of each rung **916** are connected, for example, by external conductors, such as PCB board traces, to form a multi-turn winding.

In both coupled inductors **200** and **900**, the geometry of ladder magnetic core rungs **216**, **916** and corresponding windings **204**, **904** can be optimized to minimize winding direct current (DC) resistance. FIG. 23, which shows a cross-sectional view of a winding **2304** wound around a rung **2316**, helps illustrate such optimization. Winding **2304** is analogous to windings **204**, **904**, and rung **2316** is analogous to rungs **216**, **916**. DC resistance of winding **2304** is proportional to length (L) of winding **2304**. Since L is affected only by winding top **2356** and sides **2358**, **2360**, it can be determined that L is minimized when the ratio of rung length (l) and rung height (h) is two. Accordingly, minimum DC resistance occurs when:

$$l/h=2 \quad (\text{EQN. 1})$$

Thus, in either coupled inductor **200** or **900**, winding resistance is optionally minimized by sizing the rungs and windings so that EQN. 1 applies, although doing so may cause core length **206** to be relatively long in inductor **200**. EQN. 1, however, only holds when winding **2304** is a single-turn winding. The optimal shape of rung cross-sectional area (A) becomes closer to a square as the number of turns of winding **2304** is increased.

FIG. 24 shows a perspective view of another coupled inductor **2400** having a non-uniform winding terminal distribution. Coupled inductor **2400** includes a ladder magnetic core **2402** and N windings **2404**. Although coupled inductor **2400** is shown with N being equal to eight, N could alternately be any integer greater than one. Magnetic core **2402** has a length **2406**, a width **2408**, and a height **2410**. FIG. 25 shows a front elevational view of coupled inductor **2400**, FIG. 26 shows a bottom plan view of the inductor, and FIG. 27 shows a perspective view of the inductor with a top rail **2412** of magnetic core **2402** removed.

FIG. 28 shows an exploded perspective view of magnetic core **2402**, and FIG. 29 shows a side elevational view of magnetic core **2402**. Magnetic core **2402** is formed of a magnetic material, such as a ferrite material or a powdered iron material. Magnetic core **2408** includes first and second rails **2412**, **2414** and N rungs **2416**. Rails **2412**, **2414** extend in the lengthwise **2406** direction and are joined by rungs **2416** in the heightwise direction. First rail **2412** has opposing side outer surface **2462**, **2464** separated in the widthwise **2408** direction, and first rail **2412** has opposing bottom and top outer surfaces **2428**, **2430** separated in the heightwise **2410** direction. Rungs **2416** join first rail **2412** at top outer surface **2430**. Although rails **2412**, **2414** and rungs **2416** are shown as discrete magnetic elements, two or more of these magnetic elements may be combined without departing from the scope hereof. Furthermore, in some embodiments, magnetic core **2402** is a single element magnetic core, such as a core formed by molding magnetic material in a ladder shape.

Rungs **2416** are divided into at least two separate groups **2418**, where each group **2418** includes two or more of the N rungs **2416**. Adjacent rungs **2416** within a common group **2418** are separated by a lengthwise separation distance **2420**. For instance, rungs **2416(1)** and **2416(2)** of group

2418(1) are separated by a separation distance **2420(1)**, and rungs **2416(3)** and **2416(4)** of group **2418(2)** are separated by a separation distance **2420(2)**. Adjacent rungs **2416** of different groups **2418**, in contrast, are separated by a lengthwise separation distance **2422**. For instance, rungs **2416(2)** and **2416(3)** are separated by a separation distance **2422(1)**, and rungs **2416(4)** and **2416(5)** are separated by a separation distance **2422(2)**. Each separation distance **2420** is smaller than each separation distance **2422**, so that adjacent rungs within groups **2418** are substantially closer together than adjacent rungs of different groups **2418**. For example, rung **2416(2)** is substantially closer, in the lengthwise **2406** direction, to rung **2416(1)** than to rung **2416(3)**. As another example, rung **2416(3)** is substantially closer, in the lengthwise direction, to rung **2416(4)** than to rung **2416(2)**.

Opposing ends of each winding **2404** form respective first and second solder tabs **2424**, **2426**, which are structurally capable of surface mount soldering to a common substrate, such as a PCB. See, for example, FIG. 26. Solder tabs **2424**, **2426** of each winding **2404** serve as terminals for the winding, although in some alternate embodiments, one or more of solder tabs **2424**, **2426** are replaced with a different connector type, such as a through-hole pin or a socket pin. Solder tabs **2424**, **2426** are disposed on a bottom outer surface **2428** of first rail **2412**.

Each winding **2404** typically has a common geometric shape, as shown, to promote ease of winding procurement and manufacturing simplicity. However, windings **2404** are wound around respective rungs **2416** with alternating opposing orientations, such that windings **2404(1)**, **2404(3)**, **2404(5)**, and **2404(7)** have a zero degree orientation, while windings **2404(2)**, **2404(4)**, **2404(6)**, and **2404(8)** have a 180 degree orientation. Zero degree orientation is characterized by winding **2404** wrapping around first side outer surface **2462** to reach bottom outer surface **2428**. 180 degree orientation is characterized by winding **2404** wrapping around second side outer surface **2464** to reach bottom outer surface **2428**. Thus, windings **2404** having a 180 degree orientation are the mirror image of windings **2404** having a zero degree orientation, as seen when looking in the heightwise direction. FIG. 30 shows a perspective view of a winding **2404** instance at zero degree orientation, and FIG. 31 shows a perspective view of a winding **2404** instance at 180 degree orientation, as seen when looking at coupled inductor **2400** toward first side outer surface **2462**.

Each winding **2404** is wound around a respective rung **2416** such that current flowing into each winding's first solder tab **2424** flows around the winding's respective rung **2416** in a common direction, as seen when looking cross-sectionally in the heightwise **2410** direction. For example, current flowing into each winding's first solder tab **2424** flows around the winding's respective rung **2416** in a counterclockwise direction **2432**, as seen when looking cross-sectionally from second rail **2414** towards first rail **2412**, as shown in FIG. 27. This winding configuration causes coupled inductor **2400** to have inverse magnetic coupling, when each first solder tab **2424** is electrically coupled to a respective switching node.

Spaces **2434** within ladder magnetic core **2402**, but outside of groups **2418**, provide leakage magnetic flux paths, thereby contributing to leakage inductance of windings **2404** (see FIG. 29). The fact that spaces **2434** are within magnetic core **2402** helps contain leakage magnetic flux within coupled inductor **2400**, thereby helping minimize the likelihood of electromagnetic interference from leakage magnetic flux. Although not required, magnetic core **2402** typically further includes N leakage elements or "teeth" **2438**,

where each tooth **2438** is disposed on first rail **2412** and at least partially bridges a heightwise **2410** separation distance between first and second rails **2412**, **2414**. Leakage teeth **2438** and rung groups **2418** are disposed in an alternating manner along length **2406**, as shown, for example, in FIGS. **28** and **29**. Such leakage tooth **2438** distribution helps achieve short paths for leakage fluxes from multiple windings, which minimizes core losses.

Leakage teeth **2438** decrease the leakage magnetic flux path reluctance in spaces **2434**, thereby promoting high and controllable leakage inductance values. Each leakage tooth **2438** is typically separated from second rail **2412** by a gap **2440**. Gaps **2440** help prevent magnetic saturation at high current levels, and gap **2440** dimensions can be adjusted during coupled inductor design to tune leakage inductance values. For example, leakage inductance can be increased by decreasing a thickness of gaps **2440** in the heightwise **2410** direction. Additionally, winding **2404** leakage inductance values can be adjusted during inductor **2400** design by varying the configuration, such as the size and/or composition, of leakage teeth **2438**.

In some alternate embodiments, such as where leakage teeth **2438** are formed of a magnetic material with a distributed air gap, leakage teeth **2438** completely bridge the heightwise separation distance between first and second rails **2412**, **2414**. Additionally, leakage teeth **2438** could alternately extend from second rail **2412** toward first rail **2414**, such that gaps **2440** separate leakage teeth **2438** from first rail **2412**. Furthermore, each leakage tooth **2438** could be split into first and second sub-teeth (not shown) extending into space **2434** from rails **2412** and **2414**, respectively, such that the sub-teeth are separated by a gap in the widthwise **2408** direction.

The non-uniform rung **2416** distribution along length **2406** and the alternating winding **2404** orientation causes solder tabs **2424**, **2426** to be non-uniformly distributed along length **2406**. First solder tabs **2424** are divided into different groups **2442** of two or more solder tabs **2424**, as shown in FIG. **26**. Lengthwise separation distances **2444** between adjacent first solder tabs **2424** within each group **2442** are smaller than lengthwise separation distances **2446** between adjacent solder tabs **2424** of different groups. For example, solder tab **2424(2)** is substantially closer in the lengthwise **2406** direction to solder tabs **2424(1)** than to solder tab **2424(3)**, and solder tab **2424(3)** is substantially closer in the lengthwise **2406** direction to solder tab **2424(4)** than to solder tab **2424(2)**. Such non-uniform solder tab distribution may facilitate aligning the solder tabs with an integrated circuit's terminals, such as discussed below with respect to FIG. **32**.

The configuration of magnetic core **2402** enables the majority of inductor volume to be occupied by magnetic elements, namely rails **2412**, **2414**, rungs **2416**, and leakage teeth **2438**, thereby promoting large magnetic core cross-sectional area per unit volume. Large magnetic core cross-sectional area promotes low core losses in magnetic core **2402**.

Although windings **2404** are shown as being single-turn foil windings, windings **2404** could be modified, as long as first solder tabs **2424**, or analogous terminals such as through-hole pins, are non-uniformly distributed along length **2406**. For example, in some alternate embodiments, windings **2404** are multi-turn windings, which promote large inductance values with small core losses.

Multiple instances of coupled inductor **2400** could be joined. For example, two instances of coupled inductor **2400**

could be joined in the lengthwise **2406** direction to form a coupled inductor including sixteen windings **2404**.

One possible application of coupled inductors **200**, **900**, and **2400** is in switching power converters, including but not limited to multi-phase buck converters, multi-phase boost converters, or multi-phase buck-boost converters. For example, FIG. **32** shows a top plan view of part of an eight-phase buck switching power converter **3200** including an instance of coupled inductor **200**. The outlines of windings **204** are denoted by dashed lines in FIG. **32** where obscured by magnetic core **202**. FIG. **33** is an electrical schematic of converter **3200**. Converter **3200** includes four integrated circuits **3202**, where each integrated circuit **3202** includes two buck power stages or switching circuits **3204** (not visible in FIG. **32**) and two terminal sets **3206**. Each terminal set **3206** include one or more electrical terminals, such as one or more solder balls, disposed on a bottom outer surface of integrated circuit **3202**. Terminal sets **3206** are symbolically indicated by dashed line in the FIG. **32** top plan view because the terminal sets are not visible when looking at the tops of integrated circuits **3202**. Each terminal set **3206** provides electrical interface to a switching node V_x of a respective switching circuit **3204**.

Coupled inductor **200** and integrated circuits **3202** are disposed on a PCB **3208**, and solder tabs **224**, **226** are soldered to the PCB. Each terminal set **3206** is electrically coupled to a respective first solder tab **224** by a PCB trace **3210**. Each switching circuit **3204** and its respective winding **204** form part of a respective phase **3212** of converter **3200**. Accordingly, each integrated circuit **3202** supports a respective pair of phases **3212**. For example, integrated circuit **3202(1)** supports phases **3212(1)**, **3212(2)**. Coupled inductor **200**, however, supports all eight phases **3212** of converter **3200**, such that all eight phases are magnetically coupled. Only three of the eight phases **3212** are shown in the FIG. **33** schematic to promote illustrative clarity.

Each switching circuit **3204** is electrically coupled to an input port **3216**, which is in turn electrically coupled to an electric power source **3218**. An output port **3220** is electrically coupled to an output node V_o , and each second solder tab **226** is electrically coupled to output node V_o .

A controller **3222** causes each switching circuit **3204** to repeatedly switch its respective first solder tab **224** between electric power source **3218** and ground, thereby switching its first solder tab between two different voltage levels, to transfer power from electric power source **3218** to a load (not shown) electrically coupled across output port **3220**. Controller **3222** typically causes switching circuits **3204** to switch at a relatively high frequency, such as at 100 kilohertz or greater, to promote low ripple current magnitude and fast transient response, as well as to ensure that switching induced noise is at a frequency above that perceivable by humans. Additionally, in certain embodiments, controller **3222** causes switching circuits **3204** to switch out-of-phase with respect to each other to improve transient response and promote ripple current cancellation in output capacitors **3224**. In some embodiments, controller **3222** is integrated in one or more integrated circuits **3202**. In other embodiments, controller **3222** is implemented by circuitry (not shown) external to integrated circuits **3202**.

Each switching circuit **3204** includes a control switching device **3226** that alternately switches between its conductive and non-conductive states under the command of controller **3222**. Each switching circuit **3204** further includes a free-wheeling device **3228** adapted to provide a path for current through its respective winding **204** when the control switching device **3226** of the switching circuit transitions from its

conductive to non-conductive state. Freewheeling devices **3228** may be diodes, as shown, to promote system simplicity. However, in certain alternate embodiments, freewheeling devices **3228** may be supplemented by or replaced with a switching device operating under the command of controller **3222** to improve converter performance. For example, diodes in freewheeling devices **3228** may be supplemented by switching devices to reduce freewheeling device **3228** forward voltage drop. In the context of this disclosure, a switching device includes, but is not limited to, a bipolar junction transistor, a field effect transistor (e.g., a N-channel or P-channel metal oxide semiconductor field effect transistor, a junction field effect transistor, a metal semiconductor field effect transistor), an insulated gate bipolar junction transistor, a thyristor, or a silicon controlled rectifier.

Controller **3222** is optionally configured to control switching circuits **3204** to regulate one or more parameters of converter **3200**, such as input voltage, input current, input power, output voltage, output current, or output power. Converter **3200** typically includes one or more input capacitors **3230** electrically coupled across input port **3216** for providing a ripple component of switching circuit **3204** input current. Additionally, one or more output capacitors **3224** are generally electrically coupled across output port **3220** to shunt ripple current generated by switching circuits **3204**. Input capacitors **3230**, output capacitors **3224**, electric power source **3218**, input port **3216**, and output port **3220** are not shown in FIG. **32**.

Converter **3200** could be modified to have a different number of phases **3212**. For example, converter **3200** could be modified to have only four phases **3212** and use a four-winding embodiment of coupled inductor **200**. Converter **3200** could also be modified to use one of the other coupled inductors disclosed herein, such as inductor **900** or **2400**, in place of inductor **200**. Furthermore, converter **3200** could be modified to incorporate switching circuits formed of discrete components, instead of switching circuits **3204** integrated in integrated circuits **3202**, at the cost of an increased parts count and a possible performance reduction. Moreover, converter **3200** could also be modified to have a different topology, such as a multi-phase boost or a multi-phase buck-boost converter topology, or an isolated topology, such as a flyback or forward converter topology.

Use of coupled inductor **200**, **900**, or **2400**, instead of a conventional coupled inductor, may offer one or more advantages in a multi-phase switching power converter application. For example, the non-uniform winding terminal distribution of inductors **200**, **900**, and **2400** may enable the winding terminals to be substantially aligned with terminals of associated integrated circuits, thereby helping minimize length of conductors connecting the terminals and winding terminals. For example, consider again switching converter **3200** of FIG. **32**. The non-uniform distribution of first solder tabs **224** enables the first solder tabs to be substantially aligned with integrated circuit terminal sets **3206**, thereby enabling separation distances **3232** to be relatively short. Short separation distance **3232** helps minimize trace **3210** length and associated impedance, thereby helping minimize trace conduction losses and likelihood of electromagnetic interference from traces **3210**. Accordingly, use of coupled inductor **200**, **900**, or **2400**, instead of a conventional coupled inductor, in an integrated power stage application may improve converter efficiency, reduce converter heating, and promote electromagnetic compatibility with nearby circuitry.

As another example, use of coupled inductor **200**, **900**, or **2400**, instead of a conventional coupled inductor, may enable an increase in the number of magnetically coupled phases without a significant increase in converter volume. Specifically, the non-uniform winding terminal distributions of inductors **200**, **900**, and **2400** allow windings to be placed close together, while achieving a “pin out” that allows for short connections to associated switching circuits. For instance, as discussed above with respect to FIG. **32**, the coupled inductor **200** solder tab distribution allows for short connections to integrated circuit terminal sets **3206**. Accordingly, the non-uniform winding terminal distributions of coupled inductors **200**, **900**, and **2400** helps enable close spacing of windings, thereby often allowing coupled inductors **200**, **900**, and **2400** to include more windings than conventional coupled inductors of similar size. Indeed, although coupled inductor **200** in converter **3200** has roughly the same outer dimensions as conventional coupled inductor **104** of prior art converter **100** (FIG. **1**), coupled inductor **200** has twice the number of windings as coupled inductor **104**. Thus, converter **3200** has twice the number of phases as prior art converter **100**, even though both converters occupy approximately the same volume of space.

The magnetic coupling of a large number switching power converter phases, which is potentially enabled by use of coupled inductor **200**, **900**, or **2400** instead of a conventional coupled inductor, may offer significant benefits. Applicant has discovered that increasing the number of magnetically coupled phases in a switching power converter can significantly lower per-phase switching current magnitude, even if per-phase energy storage inductance remains unchanged. For example, FIG. **34** shows an idealized graph of normalized ripple current per phase versus duty cycle, for different numbers of magnetically coupled phases, in a buck switching power converter. As can be appreciated from FIG. **34**, increasing the number of magnetically coupled phases, significantly decreases ripple current magnitude even if inductance value in each phase remains the same. Decreasing ripple current magnitude reduces conduction losses and also reduces output voltage ripple. In comparison, merely increasing the number of phases, without magnetic coupling the phases, typically requires a proportional increase in the inductance value per phase, because current per phase will decrease in proportion to the number of phases, and ripple current per phase must therefore proportionally decrease to maintain efficiency.

Furthermore, increasing the number of magnetically coupled phases reduces effective total inductance, assuming leakage inductance per phase remains unchanged as the number of magnetically coupled phases increases. A decrease in effective total inductance, in turn, allows for a faster rate of change of switching power converter current. Thus, increasing the number of magnetically coupled phases in a switching power converter may improve converter transient response.

Moreover, an increase in number of switching power converter phases normally decreases magnitude of current per phase. Such decrease in current magnitude may enable use of higher resistance inductor windings, thereby potentially allowing use of multi-turn windings. Use of multi-turn windings, in turn, helps reduce magnetic core losses by reducing required magnetic core flux density at a given inductance level.

Combinations of Features

Features described above as well as those claimed below may be combined in various ways without departing from the scope hereof. The following examples illustrate some possible combinations:

(A1) A coupled inductor may include a ladder magnetic core having a length, a width, and a height. The ladder magnetic core may include two rails extending in the lengthwise direction and joined in the widthwise direction by at least first, second, third, and fourth rungs sequentially disposed along the length of the magnetic core. The coupled inductor may further include first, second, third, and fourth windings wound at least partially around the first, second, third, and fourth rungs, respectively. The second rung may be substantially closer in the lengthwise direction to the first rung than to the third rung. The third rung may be substantially closer in the lengthwise direction to the fourth rung than to the second rung.

(A2) In the coupled inductor denoted as (A1), the ladder magnetic core may further include a first leakage tooth at least partially bridging a widthwise separation distance between the two rails, where the first leakage tooth is disposed along the length of the ladder magnetic core between the second and third rungs.

(A3) In the coupled inductor denoted as (A2), the first leakage tooth may bridge less than all of the widthwise separation distance between the two rails.

(A4) In either of the coupled inductors denoted as (A2) or (A3), the ladder magnetic core may further include a second leakage tooth at least partially bridging the widthwise separation distance between the two rails, and the third and fourth rungs may be disposed along the length of the ladder magnetic core between the first and second leakage teeth.

(A5) In any of the coupled inductors denoted as (A1) through (A4), respective ends of the first, second, third, and fourth windings may form first, second, third, and fourth solder tabs, respectively, where the first, second, third, and fourth solder tabs are structurally capable of surface mount soldering to a common substrate. The second solder tab may be substantially closer in the lengthwise direction to the first solder tab than to the third solder tab. The third solder tab may be substantially closer in the lengthwise direction to the fourth solder tab than to the second solder tab.

(A6) In the coupled inductor denoted as (A5), the two rails may include first and second rails, and each of the first, second, third, and fourth solder tabs may be at least partially disposed on a bottom outer surface of the first rail.

(A7) In either of the coupled inductors denoted as (A5) or (A6), the windings may be arranged such that current flowing into the first, second, third, and fourth solder tabs flows in a common direction around each of the first, second, third, and fourth rungs, respectively, when seen looking cross-sectionally in the widthwise direction of the magnetic core.

(A8) In any of the coupled inductors denoted as (A1) through (A7), the first, second, third, and fourth windings may have respective leakage inductance values that are substantially identical.

(B1) A coupled inductor may include a ladder magnetic core having a length, a width, and a height. The ladder magnetic core may include first and second rails extending in the lengthwise direction and joined in the widthwise direction by at least first and second rungs. The coupled inductor may further include first and second windings. The first winding may be wound, in a first orientation, at least partially around the first rung. The second winding may be wound, in a second orientation, at least partially around the

second rung, where the second orientation is opposite to the first orientation. Opposing ends of the first winding may form first and second solder tabs, respectively, and opposing ends of the second winding may form third and fourth solder tabs, respectively. The first and third solder tabs may be disposed at least partially on a bottom outer surface of the first rail, and the second and fourth solder tabs may be disposed at least partially on a bottom outer surface of the second rail. The first and second windings may be arranged such that current flowing into the first and third solder tabs flows in a common direction around each of the first and second rungs, respectively, when seen looking cross-sectionally in the widthwise direction of the magnetic core.

(B2) In the coupled inductor denoted as (B1), each of the first and second windings may have a common geometric shape.

(B3) In either of the coupled inductors denoted as (B1) or (B2), the ladder magnetic core may further include a third rung joining the first and second rails in the widthwise direction, and the coupled inductor may further include a third winding wound, in the first orientation, at least partially around the third rung.

(B4) In the coupled inductor denoted as (B3): (i) opposing ends of the third winding may form fifth and sixth solder tabs, respectively, (ii) the fifth solder tab may be disposed at least partially on the bottom outer surface of the first rail, (iii) the sixth solder tab may be disposed at least partially on the bottom outer surface of the second rail, and (iv) the windings may be arranged such that current flowing into the first, third, and fifth solder tabs flows in a common direction around each of the first, second, and third rungs, respectively, when seen looking cross-sectionally in the widthwise direction of the magnetic core.

(B5) In the coupled inductor denoted as (B4): (i) the third solder tab may be disposed, in the lengthwise direction between the first and fifth solder tabs, (ii) the fourth solder tab may be disposed, in the lengthwise direction, between the second and sixth solder tabs, and (iii) each of the second, third, and sixth solder tabs may be larger than each of the first, fourth, and fifth solder tabs.

(B6) In any of the coupled inductors denoted as (B1) through (B5), the ladder magnetic core may further include a leakage tooth extending between the first and second rails in the widthwise direction, where the leakage tooth is disposed, in the heightwise direction, over at least one of the first, second, and third rungs.

(B7) In any of the coupled inductors denoted as (B1) through (B6), the first, second, and third windings may have respective leakage inductance values that are substantially identical.

(B8) In any of the coupled inductors denoted as (B1) through (B7), each of the first and second windings may be a single-turn winding, each of the first and second rungs may have a cross section in the lengthwise and heightwise directions, and a rung length by a rung height may be substantially equal to two.

(C1) A coupled inductor may include a ladder magnetic core having a length, a width, and a height. The ladder magnetic core may include two rails joined in the heightwise direction by at least first, second, and third rungs respectively disposed along the length of the magnetic core. The coupled inductor may further include first, second, and third windings. The first winding may be wound, in a first orientation, at least partially around the first rung, and the second winding may be wound, in a second orientation opposite to the first orientation, at least partially around the second rung. The third winding may be wound, in the first

orientation, at least partially around the third rung. The second rung may be substantially closer in the lengthwise direction to the first rung than to the third rung.

(C2) In the coupled inductor denoted as (C1), each of the first, second, and third windings may have a common geometrical shape.

(C3) In either of the coupled inductors denoted as (C1) or (C2): (i) respective ends of the first, second, and third windings may form first, second, and third solder tabs, respectively, (ii) the first, second, and third solder tabs may be structurally capable of surface mount soldering to a common substrate, and (iii) the second solder tab may be substantially closer in the lengthwise direction to the first solder tab than to the third solder tab.

(C4) In the coupled inductor denoted as (C3), each of the first, second, and third solder tabs may be at least partially disposed on a bottom outer surface of a common one of the two rails.

(C5) In any of the coupled inductors denoted as (C1) through (C4): (i) the ladder magnetic core may further include a fourth rung joining the first and second rails in the heightwise direction, (ii) the third rung may be disposed, in the lengthwise direction, between the first leakage tooth and the fourth rung, (iii) the third rung may be substantially closer in the lengthwise direction to the fourth rung than to the second rung, and (iv) the coupled inductor further may include a fourth winding wound, in the second orientation, at least partially around the fourth rung.

(C6) In the coupled inductor denoted as (C5): (i) the ladder magnetic core may further include first and second leakage teeth at least partially bridging a heightwise separation distance between the two rails, (ii) the first leakage tooth may be disposed on at least one of the two rails between the second and third rungs, and (iii) the third and fourth rungs may be disposed along the length of the ladder magnetic core between the first and second leakage teeth.

(C7) In any of the coupled inductors denoted as (C1) through (C5), the ladder magnetic core may further include a first leakage tooth at least partially bridging a heightwise separation distance between the two rails, where the first leakage tooth is disposed on at least one of the two rails between the second and third rungs.

(C8) In any of the coupled inductors denoted as (C1) through (C7), the first, second, third, and fourth windings may have respective leakage inductance values that are substantially identical.

(D1) A multi-phase switching power converter may include a coupled inductor including a ladder magnetic core having a length, a width, and a height. The ladder magnetic core may include two rails extending in the lengthwise direction and joined in the widthwise direction by at least first, second, third, and fourth rungs sequentially disposed along the length of the magnetic core. The coupled inductor may further include first, second, third, and fourth windings wound at least partially around the first, second, third, and fourth rungs, respectively. The second rung may be substantially closer in the lengthwise direction to the first rung than to the third rung, and the third rung may be substantially closer in the lengthwise direction to the fourth rung than to the second rung. The multi-phase switching power converter may further include first, second, third, and fourth switching circuits, where each switching circuit is adapted to repeatedly switch an end of a respective one of the first, second, third, and fourth windings between at least two different voltage levels.

(D2) The multi-phase switching power converter denoted as (D1) may further include a controller adapted to control

the first, second, third, and fourth switching circuits such that each of the switching circuits switches out of phase with respect to at least one other of the switching circuits.

(D3) In either of the multi-phase switching power converters denoted as (D1) or (D2), the ladder magnetic core may further include a first leakage tooth at least partially bridging a widthwise separation distance between the two rails, where the first leakage tooth is disposed along the length of the ladder magnetic core between the second and third rungs.

(D4) In any of the multi-phase switching power converters denoted as (D1) through (D3): (i) the multi-phase switching power converter may further include a printed circuit board, (ii) respective ends of the first, second, third, and fourth windings may form first, second, third, and fourth solder tabs, (iii) the first, second, third, and fourth solder tabs may be soldered to the printed circuit board, (iv) the second solder tab may be substantially closer in the lengthwise direction to the first solder tab than to the third solder tab, and (v) the third solder tab may be substantially closer in the lengthwise direction to the fourth solder tab than to the second solder tab.

(E1) A multi-phase switching power converter may include a coupled inductor including a ladder magnetic core having a length, a width, and a height. The ladder magnetic core may include first and second rails extending in the lengthwise direction and joined in the widthwise direction by at least first and second rungs. The coupled inductor may further include first and second windings. The first winding may be wound, in a first orientation, at least partially around the first rung, and the second winding may be wound, in a second orientation, at least partially around the second rung, where the second orientation is opposite to the first orientation. Opposing ends of the first winding may form first and second solder tabs, respectively, and opposing ends of the second winding may form third and fourth solder tabs, respectively. The first and third solder tabs may be disposed at least partially on a bottom outer surface of the first rail, and the second and fourth solder tabs may be disposed at least partially on a bottom outer surface of the second rail. The first and second windings may be arranged such that current flowing into the first and third solder tabs flows in a common direction around each of the first and second rungs, respectively, when seen looking cross-sectionally in the widthwise direction of the magnetic core. The multi-phase switching power converter may further include first and second switching circuits, where the first switching circuit is adapted to repeatedly switch the first solder tab between at least two different voltage levels, and the second switching circuit is adapted to repeatedly switch the third solder tab between at least two different voltage levels.

(E2) The multi-phase switching power converter denoted as (D1) may further include a controller adapted to control the first and second switching circuits such that the switching circuits switch out of phase with respect to each other.

(E3) Either of the multi-phase switching power converters denoted as (E1) or (E2) may further include a printed circuit board, and the first, second, third, and fourth solder tabs may be soldered to the printed circuit board.

(E4) In any of the multi-phase switching power converters denoted as (E1) through (E3), each of the first and second windings may have a common geometric shape.

(F1) A multi-phase switching power converter may include a coupled inductor including a ladder magnetic core having a length, a width, and a height. The ladder magnetic core may include two rails joined in the heightwise direction by at least first, second, and third rungs respectively dis-

21

posed along the length of the magnetic core. The coupled inductor may further include first, second, and third windings. The first winding may be wound, in a first orientation, at least partially around the first rung, and the second winding may be wound, in a second orientation opposite to the first orientation, at least partially around the second rung. The third winding may be wound, in the first orientation, at least partially around the third rung. The second rung may be substantially closer in the lengthwise direction to the first rung than to the third rung. The multi-phase switching power converter may further include first, second, and third switching circuits, where each switching circuit is adapted to repeatedly switch an end of a respective one of the first, second, and third windings between at least two different voltage levels.

(F2) The multi-phase switching power converter denoted as (F1) may further include a controller adapted to control the first, second, and third switching circuits such that each of the switching circuits switches out of phase with respect to at least one other of the switching circuits.

(F3) In either of the multi-phase switching power converters denoted as (F1) or (F2), the ladder magnetic core may further include a first leakage tooth at least partially bridging a heightwise separation distance between the two rails, where the first leakage tooth is disposed on at least one of the two rails between the second and third rungs.

(F4) In any of the multi-phase switching power converters denoted as (F1) through (F3): (i) the multi-phase switching power converter may further include a printed circuit board, (ii) respective ends of the first, second, and third windings may form first, second, and third solder tabs, respectively, (iii) the first, second, and third solder tabs may be soldered to the printed circuit board, and (iv) the second solder tab may be substantially closer in the lengthwise direction to the first solder tab than to the third solder tab.

(F5) In the multi-phase switching power converter denoted as (F4), the two rails may include first and second rails, and each of the first, second, and third solder tabs may be at least partially disposed on a bottom outer surface of the first rail.

(F6) In any of the multi-phase switching power converters denoted as (F1) through (F5), each of the first, second, and third windings may have a common geometrical shape.

Changes may be made in the above methods and systems without departing from the scope hereof. Therefore, the matter contained in the above description and shown in the accompanying drawings should be interpreted as illustrative and not in a limiting sense. The following claims are intended to cover generic and specific features described herein, as well as all statements of the scope of the present method and system, which, as a matter of language, might be said to fall therebetween.

What is claimed is:

1. A coupled inductor, comprising:
 - a ladder magnetic core having a length, a width, and a height, the ladder magnetic core including first and second rails joined in a heightwise direction by at least first, second, and third rungs respectively disposed along the length of the magnetic core, the first rail having opposing first and second side outer surfaces separated from each other in a widthwise direction;
 - a first winding wound, in a first orientation, at least partially around the first rung, the first winding wrapping around the first side outer surface of the first rail;
 - a second winding wound, in a second orientation opposite to the first orientation, at least partially around the

22

second rung, the second winding wrapping around the second side outer surface of the first rail; and
 a third winding wound, in the first orientation, at least partially around the third rung, the third winding wrapping around the first side outer surface of the first rail; the second rung being closer in a lengthwise direction to the first rung than to the third rung.

2. The coupled inductor of claim 1, the ladder magnetic core further including a first leakage tooth at least partially bridging a heightwise separation distance between the first and second rails, the first leakage tooth being disposed on at least one of the first and second rails between the second and third rungs.

3. The coupled inductor of claim 2, each of the first, second, and third windings having a common geometrical shape.

4. The coupled inductor of claim 3, wherein:
 respective ends of the first, second, and third windings form first, second, and third solder tabs, respectively, the first, second, and third solder tabs being structurally capable of surface mount soldering to a common substrate;

the second solder tab is closer in the lengthwise direction to the first solder tab than to the third solder tab.

5. The coupled inductor of claim 4, each of the first, second, and third solder tabs being at least partially disposed on a bottom outer surface of the first rail.

6. A coupled inductor, comprising:

a ladder magnetic core having a length, a width, and a height, the ladder magnetic core including:
 first and second rails joined in a heightwise direction by at least first, second, third, and fourth rungs respectively disposed along the length of the magnetic core, and
 a first leakage tooth at least partially bridging a heightwise separation distance between the first and second rails, the first leakage tooth being disposed on at least one of the first and second rails between the second and third rungs,

the second rung being closer in a lengthwise direction to the first rung than to the third rung, the third rung being disposed, in the lengthwise direction, between the first leakage tooth and the fourth rung, the third rung being closer in the lengthwise direction to the fourth rung than to the second rung;

a first winding wound, in a first orientation, at least partially around the first rung;

a second winding wound, in a second orientation opposite to the first orientation, at least partially around the second rung;

a third winding wound, in the first orientation, at least partially around the third rung, each of the first, second, and third windings having a common geometrical shape; and

a fourth winding wound, in the second orientation, at least partially around the fourth rung;

respective ends of the first, second, and third windings forming first, second, and third solder tabs, respectively, the first, second, and third solder tabs being structurally capable of surface mount soldering to a common substrate, each of the first, second, and third solder tabs being at least partially disposed on a bottom outer surface of the first rail;

the second solder tab being closer in the lengthwise direction to the first solder tab than to the third solder tab.

23

7. The coupled inductor of claim 6, the ladder magnetic core further including a second leakage tooth at least partially bridging the heightwise separation distance between the first and second rails, the third and fourth rungs being disposed along the length of the ladder magnetic core between the first and second leakage teeth.

8. The coupled inductor of claim 7, the first, second, third, and fourth windings having respective leakage inductance values that are identical.

9. A coupled inductor, comprising:

a ladder magnetic core including opposing first and second rails extending in a lengthwise direction and joined by a plurality of rungs, the first rail having opposing first and second side outer surfaces separated from each other in a widthwise direction; and

a respective winding wound around each of the plurality of rungs;

the plurality of rungs being divided into at least two groups of rungs, a lengthwise separation distance between adjacent rungs in each group of rungs being

24

less than a lengthwise separation distance between adjacent rungs of different groups of the at least two groups;

the respective winding wound around a first rung of the plurality of rungs wrapping around the first side outer surface of the first rail;

the respective winding wound around a second rung of the plurality of rungs wrapping around the second side outer surface of the first rail.

10. The coupled inductor of claim 9, further comprising a leakage tooth at least partially bridging a separation distance between the opposing first and second rails, the leakage tooth being disposed in the lengthwise direction between two adjacent groups of the at least two groups of rungs.

15. 11. The coupled inductor of claim 10, the plurality of rungs joining the opposing first and second rails in a heightwise direction of the ladder magnetic core, and the separation distance between the opposing first and second rails being in the heightwise direction.

* * * * *