



US009700107B1

(12) **United States Patent
de Andrade**

(10) **Patent No.:** **US 9,700,107 B1**
(45) **Date of Patent:** **Jul. 11, 2017**

(54) **FASTENING STRUCTURE**

(71) Applicant: **Fabio de Andrade**, Lee's Summit, MO (US)

(72) Inventor: **Fabio de Andrade**, Lee's Summit, MO (US)

(*) Notice: Subject to any disclaimer, the term of this patent is extended or adjusted under 35 U.S.C. 154(b) by 0 days.

(21) Appl. No.: **15/202,306**

(22) Filed: **Jul. 5, 2016**

(51) **Int. Cl.**
A44B 99/00 (2010.01)
A43C 9/00 (2006.01)

(52) **U.S. Cl.**
CPC *A44B 99/00* (2013.01); *A43C 9/00* (2013.01); *Y10T 24/44043* (2015.01); *Y10T 24/44077* (2015.01)

(58) **Field of Classification Search**
CPC A44B 99/00; A44B 19/16; A44B 19/267; A43C 9/00; Y10T 24/158; Y10T 24/45152; Y10T 24/45157; Y10T 24/45162; Y10T 24/2532
See application file for complete search history.

(56) **References Cited**

U.S. PATENT DOCUMENTS

2,857,688	A *	10/1958	Haase	A43B 3/242
					2/139
2,871,539	A *	2/1959	Swan	A44B 19/16
					24/399
3,204,346	A	9/1965	Lockard et al.		
5,217,001	A	6/1993	Nakao		
5,471,684	A *	12/1995	Casale	A42B 1/064
					2/10

5,791,810	A	8/1998	Williams		
6,003,212	A	12/1999	Imahata		
6,786,641	B2	9/2004	Plourde		
7,536,758	B2 *	5/2009	Meager	A44B 19/16
					24/385
8,327,464	B2 *	12/2012	Jaros	A41F 1/00
					2/243.1
2002/0178555	A1 *	12/2002	Tsai	B65D 5/6611
					24/572.1
2006/0112596	A1	6/2006	Chan		
2006/0165316	A1	7/2006	Cheung		
2006/0165317	A1	7/2006	Gzybowski		
2007/0017072	A1	1/2007	Serio et al.		
2011/0054435	A1	3/2011	Kline et al.		
2012/0246972	A1 *	10/2012	Newkirk	A43C 11/004
					36/50.1
2013/0000089	A1	1/2013	Lee et al.		

(Continued)

FOREIGN PATENT DOCUMENTS

WO 2012066363 A1 5/2012

OTHER PUBLICATIONS

PCT Application No. PCT/US2016/041081, International Search Report and Written Opinion, dated Sep. 26, 2016, 9 pages.

Primary Examiner — Robert J Sandy
Assistant Examiner — Matthew Sullivan
(74) *Attorney, Agent, or Firm* — Lathrop & Gage L.L.P.

(57) **ABSTRACT**

Disclosed herein is a fastening structure which enables objects to be easily removeably coupled, and enables a smooth slideable coupling and decoupling. The fastening structure includes a male and female component. The male component is cross shaped with a wing member and cross bar member. The female component has a complementary structure with an elongate slot and cross groove, such that the male component is slideably received and mated.

14 Claims, 8 Drawing Sheets

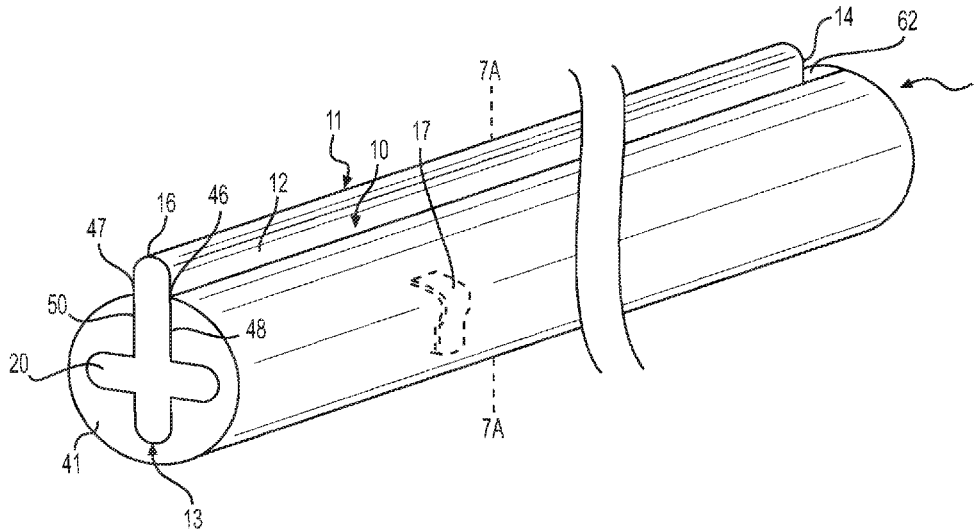

(56)

References Cited

U.S. PATENT DOCUMENTS

2014/0259571 A1 9/2014 Blythe
2015/0313323 A1* 11/2015 Domanski A44B 19/16
24/400

* cited by examiner

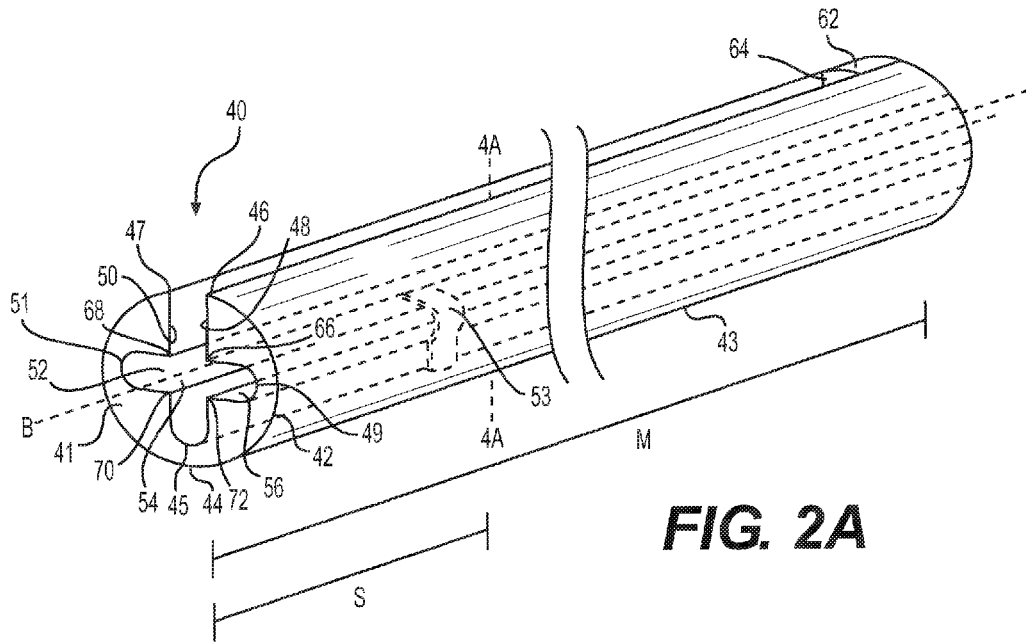

FIG. 2A

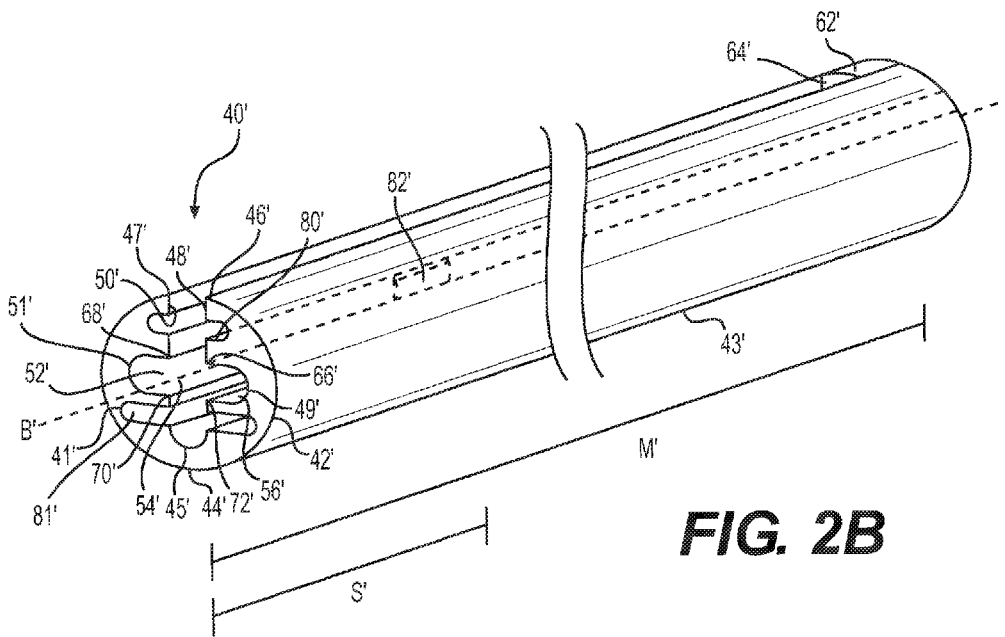

FIG. 2B

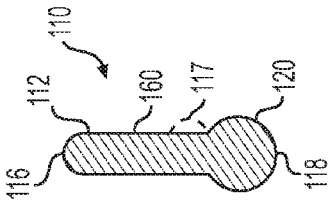

FIG. 3B

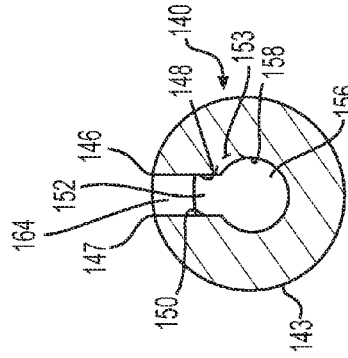

FIG. 4B

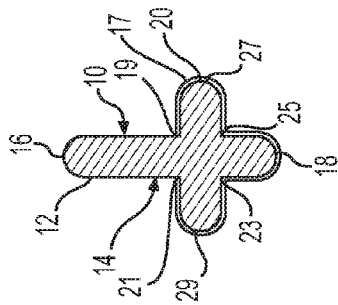

FIG. 3A

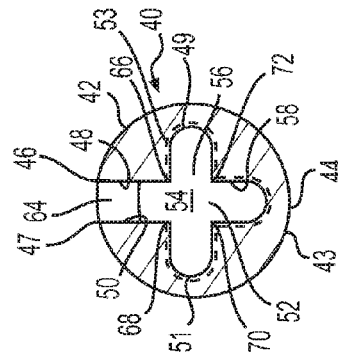

FIG. 4A

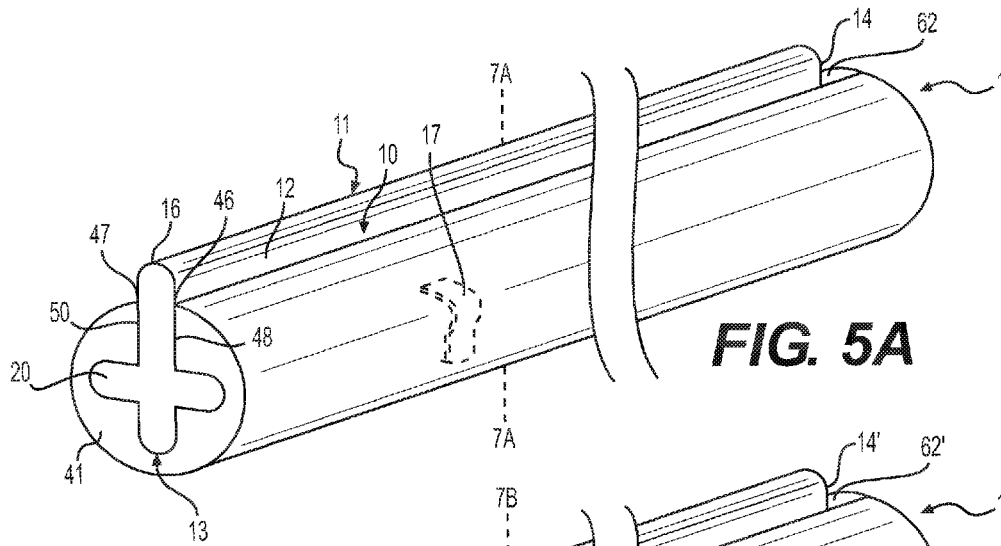

FIG. 5A

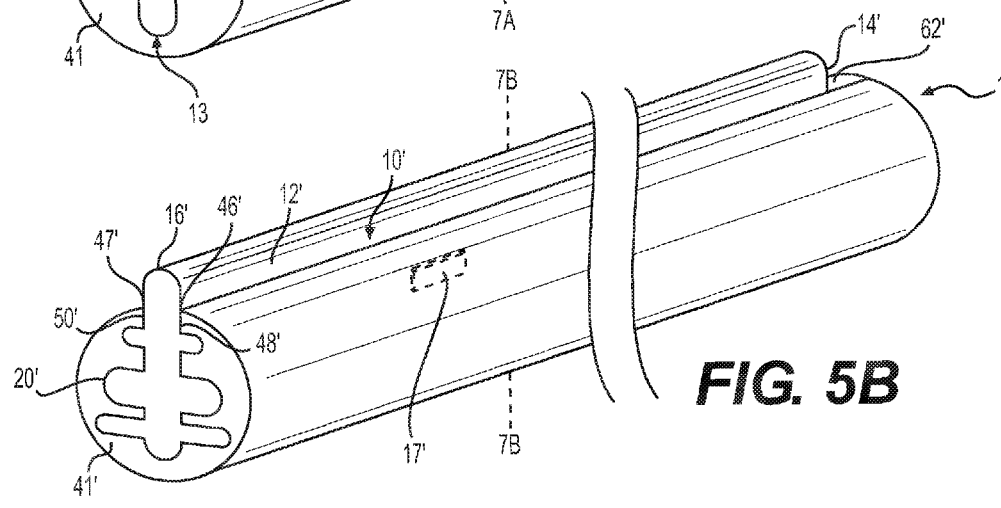

FIG. 5B

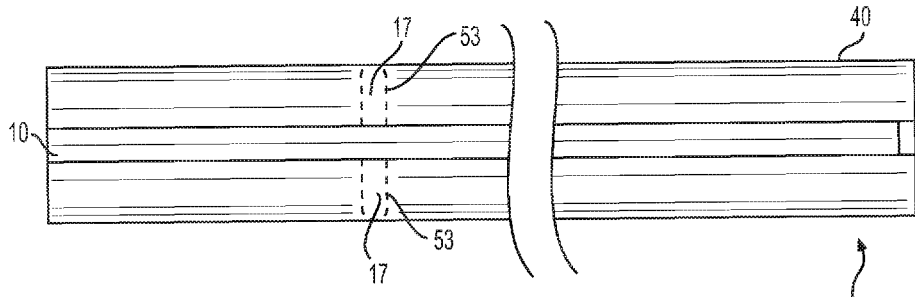

FIG. 6

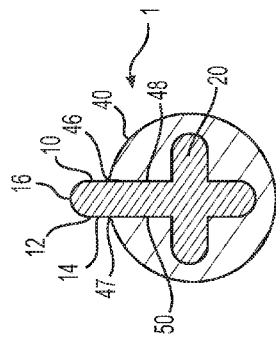

FIG. 7A

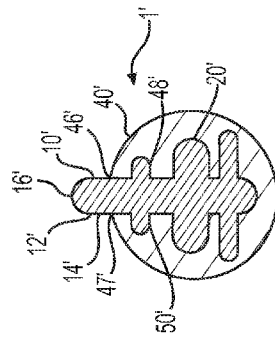

FIG. 7B

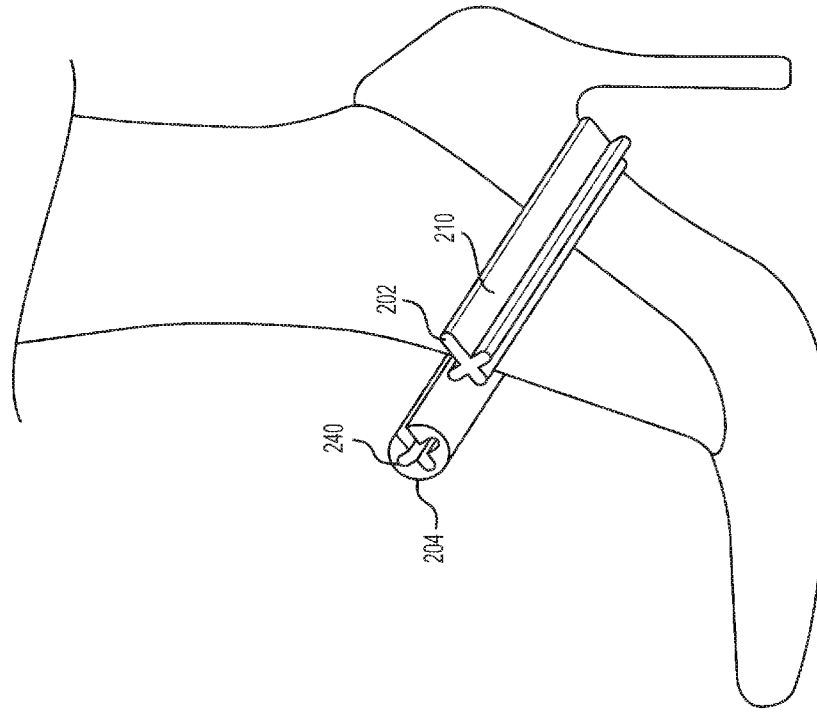

FIG. 8

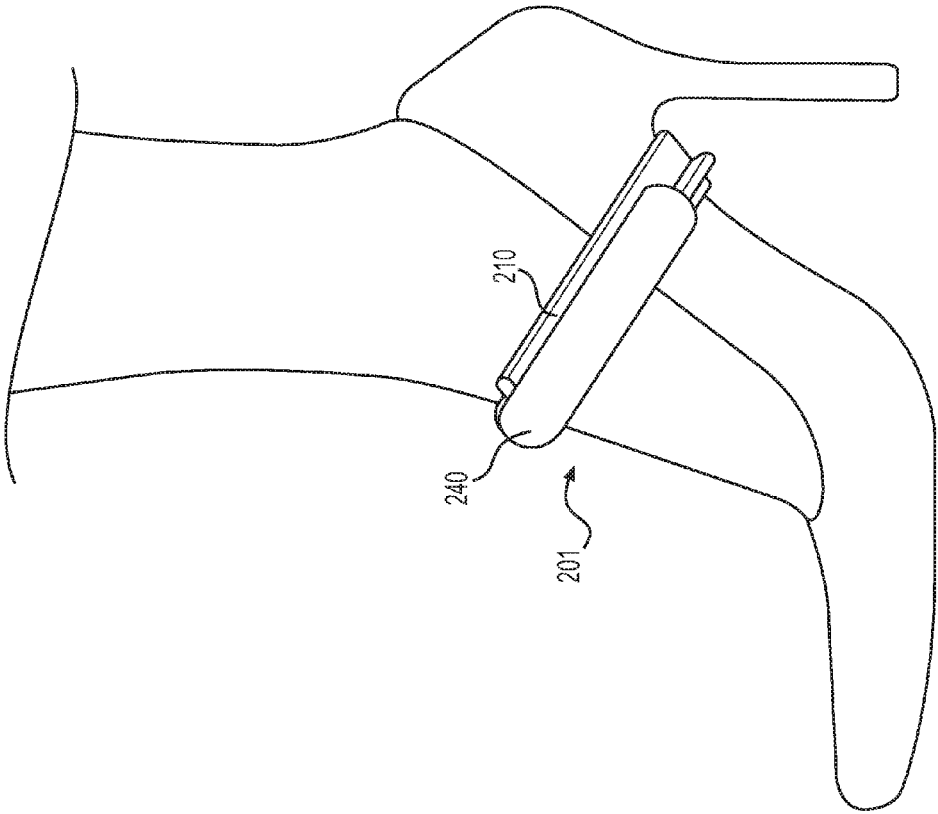
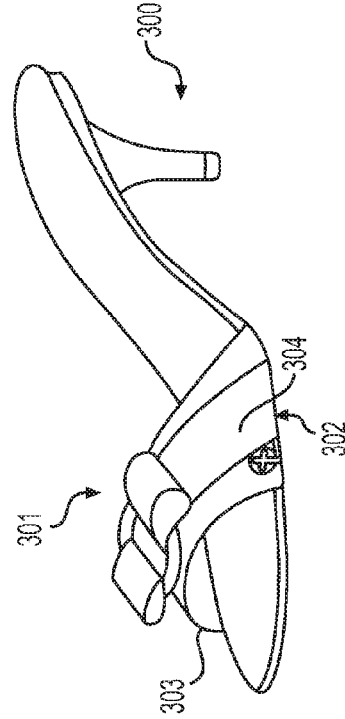
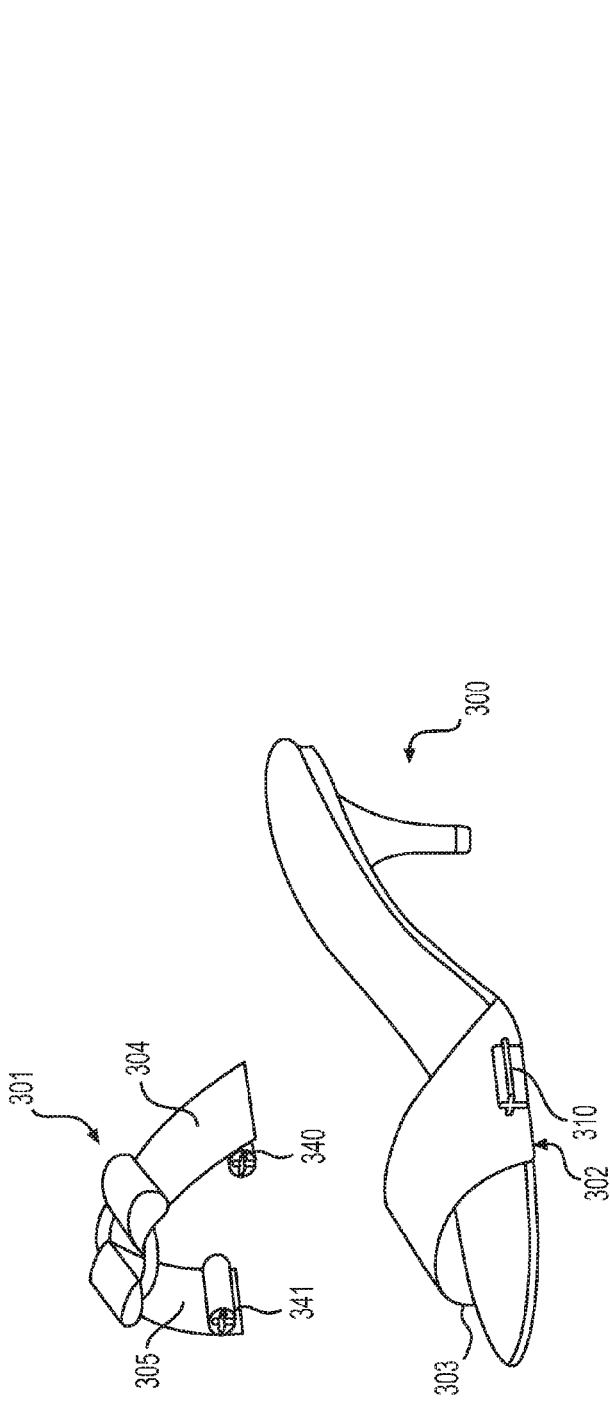

FIG. 9



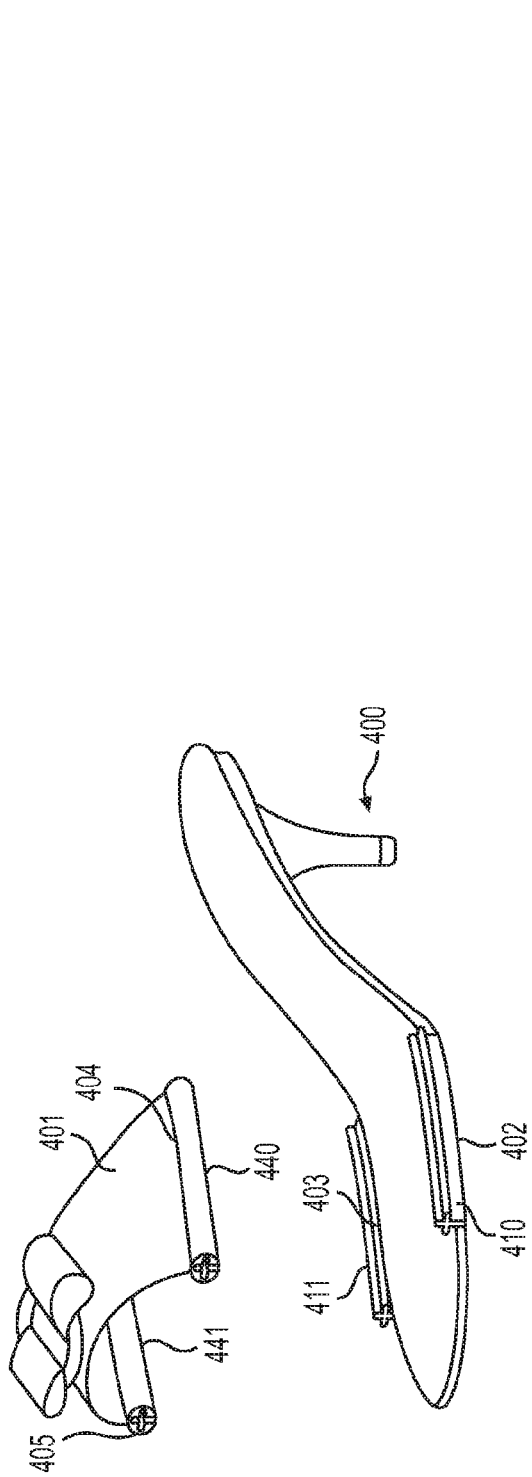

FIG. 12

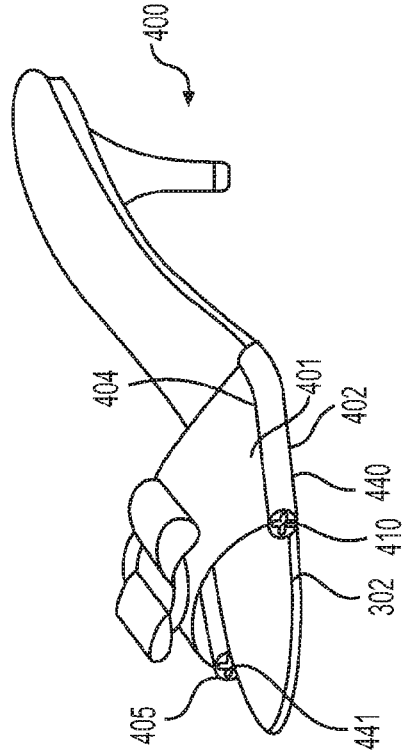

FIG. 13

FASTENING STRUCTURE

BACKGROUND OF THE INVENTION

The present invention relates, in general, to fastening structures and, more particularly, to a fastening structure which enables two objects to be easily coupled to and removed from each other. Generally, a variety of fastening means, such as double-sided tape, Velcro, Zip Lock, buttons, zippers, rivets, etc., for fastening a couple of objects to each other are known. Particularly, Velcro is widely used as representative means, along with because it is trouble-free and the installation of it is easy and it is easy to use. Velcro includes a first member which is provided with a plurality of locking hooks, and a second member which is provided with a plurality of catch loops. The first member and the second member are respectively installed on corresponding surfaces of objects and are fastened to or separated from each other depending on the coupling between the locking hooks and the catch loops. As a non-exhaustive list of objects would be straps for shoes, strollers, car seats and backpacks, sails, flexible membrane structures, tents, or any type of fabric that may have a space restriction.

However, none of these fasteners take into account a sliding mechanism that deals with axial tension issues that are created with the most stressful applications of the product design where performance of the components is located. Therefore, a fastening structure which can facilitate coupling or removal between first and second members by sliding means and deal with tension issues in equal or unequal measures is required.

BRIEF SUMMARY OF THE INVENTION

The following presents a simplified summary of the invention in order to provide a basic understanding of some aspects of the invention. This summary is not an extensive overview of the invention. It is not intended to identify critical elements of the invention or to delineate the scope of the invention. Its sole purpose is to present some concepts of the invention in a simplified form as a prelude to the more detailed description that is presented elsewhere.

The inventive device includes a male portion and a female portion that are releasably coupleable together. The male portion has a wing member upwardly extending to the top surface thereof and a cross member extending perpendicularly from the wing member. The female portion has an aperture extending through its top and a pair of perpendicular breaks or cross apertures that provide an opening through the front face of the female portion into the interior of the female portion. The aperture and the axial breaks define a groove of the female portion. The wing and cross members of the male portion having a front face that is slideably insertable in the groove of the female portion on the front face. The female portion having an outer surface that is circular in shape such that the female portion is a cylinder with an inner slot.

In one embodiment the fastening structure is coupled by force-fitting and is removed therefrom by pulling or by slideably mating or by snapping on or off or some combination of these.

In another embodiment, the front face of at least one first and second components is slanted at an angle traverse from longitudinal axis.

In another embodiment the first slideable male component further includes a second cross member and the second

slideable female component contains a second cross aperture sized and shaped to mate with the second cross member.

In one embodiment, at least one of the male and female components further includes a retaining structure such that the retaining structure mates within a groove on the other respective component so as to lock the male and female components together in a locked configuration.

In one embodiment, the second slideable component further includes a stop situated on an opposed side from the front face, wherein the stop prevents further sliding of the first slideable component along the longitudinal axis with respect to the second slideable component.

The drawings constitute a part of this specification and include exemplary embodiments of the present invention and illustrate various objects and features thereof.

BRIEF DESCRIPTION OF THE DRAWINGS

A further understanding of the invention may be had by reference to the accompanying drawing in which:

FIG. 1A is a top perspective view of the male component of the invention in a first embodiment;

FIG. 1B is a top perspective view of the male component of the invention in a second embodiment;

FIG. 2A is a top perspective view of the female component of the invention in the first embodiment;

FIG. 2B is a top perspective view of the female component of the invention in the second embodiment;

FIG. 3A is a cross sectional view of FIG. 1 taken along the line 3A-3A of the male component in the first embodiment;

FIG. 3B is a cross sectional view of the male component of the invention in a third embodiment;

FIG. 4A is a cross sectional view of FIG. 2A taken along the line 4A-4A of the female component of the invention in the first embodiment;

FIG. 4B is a cross sectional view of the female component of the invention in the third embodiment;

FIG. 5A is a top perspective view of the male and female components of the invention in the first embodiment mated;

FIG. 5B is a top perspective view of the male and female components of the invention in the second embodiment mated;

FIG. 6 is a top view of the male and female components of the invention in the first embodiment mated with portions of the retaining mechanism shown in phantom;

FIG. 7A is a cross sectional view of FIG. 5A taken along the line 7A-7A of the male and female components of the invention mated;

FIG. 7B is a cross sectional view of FIG. 5B taken along the line 7B-7B of the male and female components of the invention mated;

FIG. 8 is a top perspective view of the male and female components in use with a shoe strap uncoupled.

FIG. 9 is a top perspective view of the male and female components in use with a shoe strap coupled.

FIG. 10 is a top perspective view of the male and female components in use, with a shoe having the male component and a shoe decoration having the female component.

FIG. 11 is a top perspective view of the male and female components coupled in use with a shoe decoration assembled with a shoe.

FIG. 12 is a top perspective view of the male and female components in use, with a shoe having the male component attached to the sole and a strap having the female component.

3

FIG. 13 is a top perspective view of the male and female components coupled in use with the shoe assembled with the shoe strap.

DETAILED DESCRIPTION OF THE INVENTION

As required, detailed embodiments of the present invention are disclosed herein; however, it is to be understood that the disclosed embodiments are merely exemplary of the invention, which may be embodied in various forms. Therefore, specific structural and functional details disclosed herein are not to be interpreted as limiting, but merely as a basis for the claims and as a representative basis for teaching one skilled in the art to variously employ the present invention in virtually any appropriately detailed structure. It is also noted that any reference to the words top, bottom, up and down, and the like, in this application refers to the alignment shown in the various drawings, as well as the normal connotations applied to such devices, and is not intended to restrict positioning of the connecting member assemblies of the application and cooperating bone anchors in actual use.

It will be appreciated that the figures teach by way of example and not limitation. The number of system components may be increased or decreased with respect to what is shown. Ideally, the top and bottom faces of each portion lie in substantially parallel planes to one another. The front and back faces of each portion lie in substantially parallel planes to one another. The side faces of each portion lie in substantially parallel planes to one another substantially perpendicular to the planes of the front and back faces. The planes of the front, back, and side faces extend substantially perpendicular to the planes of the top and bottom faces.

As best illustrated in FIGS. 1A, 2A-4A, in one embodiment, a fastener device 1 comprises a male component 10 and a female component 40 that are releasably coupleable together.

Referring to FIGS. 1A and 3A, the male portion or component 10 includes flat planar front face 15. It is foreseen that the plane of the front face 15 may be at a slanted angle to allow for easier insertion of the male component 10. The male component 10 includes an elongate wing member 12 extending from a top 11 to a bottom 13 thereof. The wing member 12 extends about an axis A for a length L (FIG. 1). The wing member 12 includes a flat upper attaching portion 14 having an upper end 16 and a lower end 18. It is foreseen that the ends 16, 18 may be squared off, pointed, or other geometric shape than the rounded edges illustrated.

Located between the upper and lower ends 16, 18 is a protuberance or cross member 20 projecting laterally which serves as a stop or positioning guide for slideably positioning the female component 40 when being attached thereto. The cross member 20 creates edges 19, 21, 23, 25 where the cross member intersects the wing member 12. Like the wing member 12, the cross member 20 has side edges 27, 29 that may be squared off, pointed, or other geometric shape than the rounded edges illustrated. It is foreseen that the cross member 20 may be at various angles, for example making an arrow-shaped pointing upward or downward, or opposite where the cross member 20 may not create a mirror image on either side of the wing member 12. This means that the edges 19, 21, 23, 25 do not necessarily have to create an equal angle, i.e. 90 degrees. Edges 19, 21, 23, 25 may be rounded or curved or otherwise connected. The cross member 20 extends about the axis A for the length L. A thickness

4

of the cross member 20 is illustrated as being substantially similar to a thickness of the wing member 12. It is foreseen that the thickness of the cross member 20 may be different from the thickness of wing member 12. In the illustrated example, the cross member 20 crosses the wing member 12 below a center C of the wing member 12, but it is foreseen that the cross member 20 may be above or below center C. The cross member 20 may be of a cross sectional dimension W that is equal or different to the height H of the wing member 12. In the illustrated example, dimension W is less than dimension H.

A retaining mechanism or resistance bar 17 is there to prevent easy pull-out of the male component 10 from the female component 40 and to resist or stop those tensional forces. The retaining mechanism 17 is located along a length R of the length L and follows the contours of the outer circumference of the cross member 20 and a bottom portion 28 of the wing member 12. The retaining member 17 is dimensionally sized to be larger than the cross member 20 and the wing member 12, and is sized and shaped to be mated within a groove 53 in the female component 40. It is foreseen that the retaining mechanism 17 may also be a bump, protuberance, hump, or bulge enough to create a tension lock that requires some force and expansion of the female component 40 to break the lock. It is also foreseen that the retaining structure may be a slot, groove, aperture, or the like with the mating structure on the female component instead of the male component as illustrated.

Referring now to FIG. 1B, the male component 10' is substantially similar to male component 10, with the exception of cross members 30' and 31' and a bump 17'. It is also foreseen that the cross members 20', 30', 31' and bump 17' may be of a different dimension than what is illustrated. In the illustrated embodiment, cross member 30' is dimensionally shorter in width than cross member 20' and located above a center C' of a height H'. Cross member 31' is slightly longer in width than cross member 20' and located below the center C' of the height H'. The bump 17' is configured to create a tension lock that requires some force and expansion of the female component 40 to break the lock. It is foreseen that more than one bump 17' may be a part of the male component. It is also foreseen that the retaining member 17' may be a slot, groove, or aperture with the female component 40' having the mating structure to complement the retaining member 17'.

It is foreseen that the cross members 20', 30', 31' may be at various angles, for example making an arrow-shaped pointing upward or downward, or opposite where the cross members 20', 30', 31' may not create a mirror image on either side of the wing member 12'. The cross members 20', 30', 31' extend about the axis A' for a length L'. A thickness of the cross members 30', 31' is illustrated as being thinner than that of the wing member 12' and the cross member 20'. It is foreseen that the thickness of the cross members 30', 31' may be similar or larger than the thickness of wing member 12' or of cross member 20'. The cross bars 20', 30', 31' are there to prevent easy pull-out of the male component 10' from the female component 40' (FIG. 2B) and to resist or stop those tensional forces. It is also foreseen that there may be any number of cross members situated about the wing member.

Referring to FIGS. 2A and 4A, the elongate female component or strip 40 has a complementary construction to the male component 10. The female component has a circular outer surface 42 that extends about an axis B for a length M. It is foreseen that length M is substantially similar to length L (FIG. 2A). The female component 40 includes

5

flat planar front face 41. It is foreseen that the plane of the front face 41 may be at a slanted angle to allow for easier insertion of the male component 10. The female component 40 includes a generally circular lower attaching portion 43 with a lower end 44 and upper free edges 46, 47. It is foreseen that the lower attaching portion 43 may be flat. The free edges 46, 47 are opposing two semi-cylindrical half portions 48, 50, which are separated by the free edges 46, 47 to form an elongate slot 52 perpendicular to the longitudinal axis B. The elongate slot 52 has an end 45. It is foreseen that the end 45 may be squared off, pointed, or other geometric shape than the rounded edges illustrated, so as to mate with the end 18 of the male component 10.

A groove or slot or cutout 53 is there to mate with retaining mechanism 17 to prevent easy pull-out of the male component 10 from the female component 40 and to resist or stop those tensional forces. The groove 53 is located along a length S of the length M and follows the contours of an internal space 54 which is mateably sized and shaped to mate with the outer circumference of the cross member 20 and a bottom portion 28 of the wing member 12. The groove 53 is dimensionally sized to be larger than the cross member 20 and the wing member 12, and is sized and shaped to be mated with the retaining mechanism of the male component 10.

The female component internal space 54 has internal dimensions substantially equal to the external dimensions of the male member 10. Located between the upper edges and lower edge 45, 46, 47 is a cross aperture, groove or slot 56 projecting laterally which serves as a positioning guide and mateably sized for slideably positioning the male cross member 20 when being attached thereto. The groove or slot 56 defines ends 49, 51 of internal surface 58. It is foreseen that the ends 49, 51 may be squared off, pointed, or other geometric shape than the rounded edges illustrated, so as to mate with the ends 27, 29 of the male component 10. The cross aperture 56 extends laterally from the slot 52 about the axis B for the length L'. It is foreseen that the cross aperture 56 may not extend the entire length of L'. A thickness of the cross aperture 56 is illustrated as being substantially similar to a thickness of the elongate slot 52. It is foreseen that the thickness of the cross aperture 56 may be different from the thickness of elongate slot 52. In the illustrated embodiment, the thickness of slots 52, 56 are substantially similar to the thickness of wing member 12 and cross member 20 of the male component, such that the male mateable fits within the female component 40.

It is foreseen that the cross aperture 56 may be above or below center of the elongate slot 52. It is also foreseen that there may be more than one cross aperture (FIG. 2B) situated either above or below the cross aperture 56, dependent upon whether or not the male component 10 has a like structure.

The female component 40 has a stop 62 with a stop surface 64 that would aid in preventing the further sliding of the male component back face moving past the female component back face (not shown).

Referring to FIG. 2B, a second embodiment of the female component 40' is shown. The female component 40' is substantially similar to the female component 40, with the exception of cross apertures 80', 81' and slot or groove 53'. Located between the upper edges and lower edge 46', 47', 66', 68 is a cross aperture, groove or slot 80' projecting laterally which serves as a positioning guide and mateably sized for slideably positioning the male cross member 30' when being attached thereto. The cross apertures 80', 81' extends laterally from the slot 52' about the axis B' for the

6

length M'. It is foreseen that the cross apertures 56', 80', 81' may not extend the entire length of M'. In the illustrated embodiment, the thickness of slots 52', 56', 80', 81' are substantially similar to the thickness of wing member 12' and cross members 20', 30', 31' of the male component, such that the male mateable fits within the female component as seen in FIGS. 5B and 7B.

Referring to FIGS. 5A-5B, the male component 10/10' can be forced into the internal space 54/54' of the female component 40/40'. The internal surface 58 includes edges 66, 68, 70, 72, which are dimensioned to mate with edge 19, 21, 23, 25, as is best illustrated in FIGS. 5A, 6 and 7A. The retaining member or bump 17/17' is slotted into the groove 53/53' ideally such that the face of the male member 10/10' engages the stop surface 64/64', thereby creating a locked configuration. In this way, the fastening structure 1/1' mates together to avoid radial tension, but allows for sliding movement in one direction only, although some friction where the retaining mechanism 17/17' mates with the groove 53/53' may have to be overcome. It is foreseen that the fastener 1/1' may not include a retaining mechanism 17/17' or a groove 53/53'.

By avoiding a too tight fit relationship when the male member 10/10' is received within the female member 40/40', it will be appreciated that the female member 40/40' can slide about the longitudinal length L/L' of the male member 10/10' or vice versa. On the other hand, the clearance between these members 10/10', 40/40', when engaged, cannot be excessive because control would be lost over the movements of the either component 10/10', 40/40' which could inadvertently slide along and out of the respective component 40/40', 10/10'. Therefore, a close fit or friction fit that provides some contact and friction is preferable. However, by ensuring that an internal surface 58/58' of the internal slot 54/54' of the female component 40/40' and an external surface 60/60' of the male component 10/10' are smooth, with the appropriate relative dimensions, the two members can slide easily relative to each other without binding. For example, the male and female components 10/10', 40/40' can be extruded polyethylene.

It is foreseen that one of the semi-cylindrical half portions 48, 50 may be resilient or deformable, although in the embodiment being described above, it is understood they are all resilient. If the female component 40 is deformable, this would allow for a snap on coupling rather than a slide on coupling.

Referring to FIGS. 3B and 4B, a third embodiment of the present invention is illustrated. The male member 110 is envisioned to be substantially similar to member 10 with these exceptions. In this embodiment, a male member 110 includes an elongate wing member 112 and a bulbous circular portion 120 having an outer surface 160. The female member 140 is envisioned to be substantially similar to female member 40 with these exceptions. In this embodiment, a female member 140 includes an elongate slot 152 and a circular slot, groove, aperture 156 defining an inner chamber 158 that is sized and shaped to mate (not shown) with the circular portion 120 of the male member 110.

It is foreseen that a plurality of fasteners may be provided, each of the fasteners comprising a male portion and a female portion as set forth above, and situated about a plane (not shown) to slideably mate with a mating plurality of fastener structures that situated about a second plane (not shown).

Referring to FIGS. 8-9, an illustrated example of the fastener structure is shown in conjunction with a shoe strap 201 on a shoe 200. The male portion 210 is attached to an end 202 of the shoe strap 201. It is foreseen that the whole

strap from beginning (not shown) to end **202** could be in the shape of the male component. The female portion **240** is attached to an opposed end **204** of the shoe strap **201**. In FIG. **8**, the male component **210** is inserted through the female component **240** such that the two components **210**, **240** are coupled and connected. It also foreseen that the strap may be located anywhere on the shoe **200** and not limited to near the toe section. It is foreseen that the male component **210** may be interchanged with the female component **240** and vice versa.

Referring to FIGS. **9-10**, an illustrated example of the fastener structure is shown in conjunction with a shoe **300**. Male components or portions **310**, **311** are attached (i.e. sewn) to an ends **302**, **303** of the shoe strap **301**. The female portions or components **340**, **341** are attached (i.e. sewn) to opposed sides **304,305** along a length of the shoe strap decoration **301**. In the illustrated embodiment the shoe strap decoration is a bow, but the illustrated example is not meant to be limiting on the shoe decorations, which may further include ribbons, fluffs, mirrors, wisps, fringe, pearls, semi-precious stones or metals, precious stones or metals, or the like, etc. In FIG. **10**, the male components **310**, **311** are inserted through the respective female components **340**, **341**, such that the two components **310**, **340** and **311**, **341** are coupled and connected. It is foreseen that the male component **310**, **311** or male components **310**, **311** may be interchanged with female components **340,341** and vice versa. It also foreseen that the strap may be located anywhere on the shoe **300** and not limited to near a toe section as illustrated. The fastener components **310**, **311**, **340**, **341** are oriented along the bottom of shoe decoration **301** and traverse to the length of the shoe **300**. It is foreseen that the fastener components **310**, **311**, **340**, **341** may be oriented in a direction along the length of the shoe **300** or side of the shoe decoration **301** (as best seen in FIGS. **11-12**). It is foreseen the decorations may also attach to other garments or accessories such as belts, hats, clothing, gear, etc, and should not be limited to shoes.

Referring to FIGS. **11-12**, an illustrated example of the fastener structure is shown in conjunction with a shoe **400**. Male components or portions **410**, **411** are attached (i.e. sewn) to an ends **402**, **403** of the shoe strap **401**, preferable at the sole. The female portions or components **440**, **441** are attached (i.e. sewn) to opposed sides **404**, **405** along a side length of the shoe strap **401**. In FIG. **12**, the male components **410**, **411** are inserted through the respective female components **440**, **441**, such that the two components **410**, **440** and **411**, **441** are coupled and connected. It is foreseen that the male component **410**, **411** or male components **410**, **411** may be interchanged with female components **440**, **441** and vice versa. It also foreseen that the strap **401** may be located anywhere on the shoe **400** and not limited to near a toe section as illustrated. The fastener components **410**, **411**, **440**, **441** are oriented along a length of the shoe **400** and strap **401**. It is foreseen that the fastener components **410**, **411**, **440**, **441** may be oriented in a direction traverse to the length of the shoe **400** or side of the shoe strap **401** (as best seen in FIGS. **8-9**).

Many different arrangements of the various components depicted, as well as components not shown, are possible without departing from the spirit and scope of the present invention. Embodiments of the present invention have been described with the intent to be illustrative rather than restrictive. Alternative embodiments will become apparent to those skilled in the art that do not depart from its scope. A skilled artisan may develop alternative means of implementing the aforementioned improvements without departing from the

scope of the present invention. Further, it will be understood that certain features and subcombinations may be of utility and may be employed within the scope of the disclosure. Further, various steps set forth herein may be carried out in orders that differ from those set forth herein without departing from the scope of the present methods. This description shall not be restricted to the above embodiments.

It is to be understood that while certain forms of the present invention have been illustrated and described herein, it is not to be limited to the specific forms or arrangement of parts described and shown.

What is claimed is as follows:

1. A fastening structure for fastening a plurality of objects to each other, the fastening structure comprising:

a first slideable component being elongate about a longitudinal axis and having a front face, an first member being elongate about a generally vertical axis and having first and second opposed sides, a second member being elongate about a generally perpendicular angle to the vertical axis and having first and second opposed sides, the second member being located on the at least one of the first and second sides of the first member, such that both first and second sides of the second member engage the at least one of the first and second sides of the first member, a first space is created adjacent the at least one of the first and second side of the first member and the first side of the second member and a second space is created adjacent the at least one of the first and second side of the first member and the second side of the second member, each of the first and second members extending along a first length about the longitudinal axis;

a second slideable component being elongate about the longitudinal axis and having a front face, a first slot being elongate about the generally vertical axis and defining first and second opposed interior sides, a second slot being elongate about the generally perpendicular angle to the vertical axis and defining first and second opposed interior sides, such that both first and second sides of the second slot engage at least one of the first and second interior sides of the first slot, each of the first and second elongate slots extending along a second length about the longitudinal axis, and wherein the first and second slideable components being engaged and slideably movable relative to each other along the respective first and second lengths thereof, one of said first and second slideable components receiving the other of said first and second slideable components whereby the first member and second members are situated within the first and second slots, respectively, and

wherein at least one of the first and second slideable components further include a retaining structure such that the retaining structure mates within a groove on the other respective component such that the first and second slideable components resist separation from each other.

2. The fastening structure of claim 1, wherein the first slideable component is coupled to the second slideable component by force-fitting and is removed therefrom by pulling.

3. The fastening structure of claim 1, wherein the first slideable component is coupled to the second slideable component by snapping on and is removed by snapping off.

4. The fastening structure of claim 1, wherein the first slideable component is coupled to the second slideable component by slide on and is removed by snapping off.

5. The fastening structure of claim 1, wherein the first slideable component is coupled to the second slideable component by slideably mating on and is removed by pulling off.

6. The fastening structure of claim 1, wherein the first slideable component further includes a third member, the third member having first and second opposed sides and being located on at least one of the first and second sides of the first member, such that both first and second sides of the third member engage at least one of the first and second sides of the first member, a third space is created adjacent the at least one of the first and second sides of the first member and the first side of the second member and a fourth space is created adjacent the at least one of the first and second sides of the first member and the second side of the second member and wherein

the second slideable component further includes a third slot sized and shaped to mate with the third member.

7. The fastening structure of claim 6, wherein the second member passes through first and second opposed sides of the first member, such that a plus sign shape is generally created.

8. The fastening structure of claim 1, wherein the second slideable component further includes a stop situated on an opposed side from the front face, wherein the stop prevents further sliding in a first direction of the first slideable component along the longitudinal axis with respect to the second slideable component.

9. The fastening structure of claim 1, wherein the second slideable component has an outer surface that is circular in dimension.

10. The fastening structure of claim 1, wherein the front face of the first slideable component is inserted into the front face of the second slideable component.

11. The fastening structure of claim 1, wherein the retaining structure is at least one of a bump, a protuberance, a hump, and a bulge extending in either the longitudinal or traverse direction.

12. The fastening structure of claim 11, when in the locked configuration, the fastening structure requiring a force in one direction to slide the first and second slideable components apart in an unlocked configuration.

13. A shoe strap separate from a shoe, the shoe strap and shoe each having a fastening structure for fastening to each other, the fastening structure comprising:

a first slideable component being elongate about a longitudinal axis and having a front face, an first member being elongate about a generally vertical axis and

having first and second opposed sides, a second member being elongate about a generally perpendicular angle to the vertical axis and having first and second opposed sides, the second member being located on the at least one of the first and second sides of the first member, such that both first and second sides of the second member engage the at least one of the first and second sides of the first member, a first space is created adjacent the at least one of the first and second side of the first member and the first side of the second member and a second space is created adjacent the at least one of the first and second side of the first member and the second side of the second member, each of the first and second members extending along a first length about the longitudinal axis;

a second slideable component being elongate about the longitudinal axis and having a front face, a first slot being elongate about the generally vertical axis and defining first and second opposed interior sides, a second slot being elongate about the generally perpendicular angle to the vertical axis and defining first and second opposed interior sides, such that both first and second sides of the second slot engage at least one of the first and second interior sides of the first slot, each of the first and second elongate slots extending along a second length about the longitudinal axis, and wherein the first and second slideable components being engaged and slideably movable relative to each other along the respective first and second lengths thereof, one of said first and second slideable components receiving the other of said first and second slideable components whereby the first member and second members are situated within the first and second slots, respectively, and

wherein at least one of the first and second slideable components further include a retaining structure such that the retaining structure mates within a groove on the other respective component such that the first and second slideable components resist separation from each other.

14. The fastening structure of claim 13, wherein the shoe strap further includes a decoration selected from at least one of the list of: bows, ribbons, fluffs, mirrors, wisps, fringe, pearls, metals, plastics, semi-precious stones, and precious stones.

* * * * *