



US011026718B2

(12) **United States Patent**
Sanghera et al.

(10) **Patent No.:** **US 11,026,718 B2**

(45) **Date of Patent:** **Jun. 8, 2021**

(54) **DELIVERY SYSTEM FOR CARDIAC PACING**

(71) Applicant: **AtaCor Medical, Inc.**, San Clemente, CA (US)

(72) Inventors: **Rick Sanghera**, San Clemente, CA (US); **Alan Marcovecchio**, San Clemente, CA (US); **Sean McGeehan**, Rancho Santa Fe, CA (US)

(73) Assignee: **ATACOR MEDICAL, INC.**, San Clemente, CA (US)

(*) Notice: Subject to any disclaimer, the term of this patent is extended or adjusted under 35 U.S.C. 154(b) by 9 days.

(21) Appl. No.: **16/267,255**

(22) Filed: **Feb. 4, 2019**

(65) **Prior Publication Data**

US 2019/0167981 A1 Jun. 6, 2019

Related U.S. Application Data

(63) Continuation of application No. 14/846,648, filed on Sep. 4, 2015, now Pat. No. 10,195,422.
(Continued)

(51) **Int. Cl.**
A61N 1/05 (2006.01)
A61N 1/365 (2006.01)
(Continued)

(52) **U.S. Cl.**
CPC **A61B 17/3423** (2013.01); **A61N 1/0504** (2013.01); **A61N 1/0587** (2013.01);
(Continued)

(58) **Field of Classification Search**

CPC A61N 1/0592; A61N 1/362; A61N 1/0587; A61N 1/0504; A61N 1/37211;
(Continued)

(56) **References Cited**

U.S. PATENT DOCUMENTS

4,030,509 A 6/1977 Heilman
4,146,037 A 3/1979 Flynn
(Continued)

FOREIGN PATENT DOCUMENTS

EP 0668087 8/1995
EP 1530983 A2 5/2005
(Continued)

OTHER PUBLICATIONS

Brown, Charles G., et. al. 'Injuries Associated with Percutaneous Placement of Transthoracic Pacemakers.' *Annals of Emergency Medicine* 14.3 (1985): 223-28.

(Continued)

Primary Examiner — Mallika D Fairchild

(74) *Attorney, Agent, or Firm* — Pillsbury Winthrop Shaw Pittman LLP

(57) **ABSTRACT**

A delivery device for installing a medical device in a patient comprising a body portion having a proximal end and a distal end, the distal end having a chisel shaped tip, a receptacle disposed in the distal end of the body portion for receiving a medical device for implanting in the patient, a handle disposed at the proximal end of the body portion for facilitating advancement of the proximal end of the body portion into the patient.

20 Claims, 18 Drawing Sheets

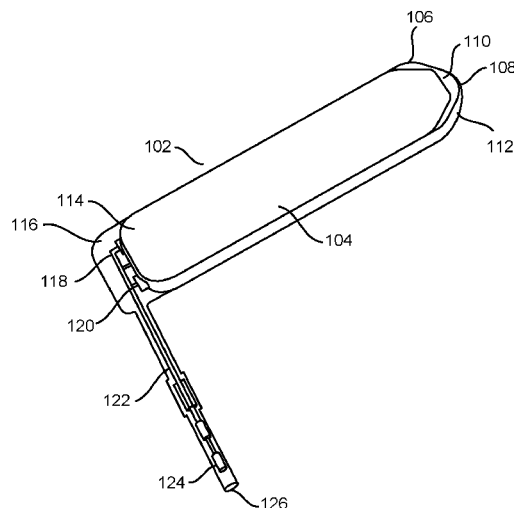

Related U.S. Application Data

(60) Provisional application No. 62/146,569, filed on Apr. 13, 2015, provisional application No. 62/083,516, filed on Nov. 24, 2014, provisional application No. 62/045,683, filed on Sep. 4, 2014.

(51) **Int. Cl.**

A61N 1/375 (2006.01)
A61B 17/34 (2006.01)
A61N 1/362 (2006.01)
A61N 1/372 (2006.01)
A61M 25/00 (2006.01)
A61M 25/06 (2006.01)

(52) **U.S. Cl.**

CPC *A61N 1/0592* (2013.01); *A61N 1/365* (2013.01); *A61N 1/3629* (2017.08); *A61N 1/3655* (2013.01); *A61N 1/36542* (2013.01); *A61N 1/36564* (2013.01); *A61N 1/37211* (2013.01); *A61B 17/3468* (2013.01); *A61B 2017/3427* (2013.01); *A61B 2017/3482* (2013.01); *A61B 2017/3488* (2013.01); *A61B 2017/3492* (2013.01); *A61M 25/00* (2013.01); *A61M 25/06* (2013.01); *A61M 2205/587* (2013.01); *A61N 1/059* (2013.01); *A61N 1/3752* (2013.01)

(58) **Field of Classification Search**

CPC *A61N 1/36564*; *A61N 1/3655*; *A61N 1/36542*; *A61N 1/365*; *A61N 1/059*; *A61N 1/3629*; *A61N 1/3752*
 See application file for complete search history.

(56) **References Cited**

U.S. PATENT DOCUMENTS

4,270,549 A 6/1981 Heilman
 4,280,510 A 7/1981 ONeill
 4,291,707 A 9/1981 Heilman
 4,306,560 A 12/1981 Harris
 4,437,475 A 3/1984 White
 4,512,351 A 4/1985 Pohndorf
 4,532,931 A 8/1985 Mills
 4,538,624 A 9/1985 Tarjan
 4,636,199 A 1/1987 Victor
 4,765,341 A 8/1988 Mower
 4,787,389 A 11/1988 Tarjan
 4,832,687 A 5/1989 Smith, III
 4,846,191 A 7/1989 Brockway
 4,865,037 A 9/1989 Chin
 5,036,854 A 8/1991 Schollmeyer
 5,125,904 A 6/1992 Lee
 5,129,394 A 7/1992 Mehra
 5,176,135 A 1/1993 Fain
 5,203,348 A 4/1993 Dahl
 5,255,691 A 10/1993 Otten
 5,255,692 A 10/1993 Neubauer
 5,273,053 A 12/1993 Pohndorf
 5,300,106 A 4/1994 Dahl
 5,312,355 A 5/1994 Lee
 5,336,252 A 8/1994 Cohen
 5,364,361 A 11/1994 Battenfield
 5,391,156 A 2/1995 Hildwein
 5,441,504 A 8/1995 Pohndorf
 5,456,699 A 10/1995 Armstrong
 5,476,493 A 12/1995 Muff
 5,509,924 A 4/1996 Paspas
 5,534,018 A 7/1996 Wahlstrand
 5,545,205 A 8/1996 Schulte
 5,562,677 A 10/1996 Hildwein
 5,571,215 A 11/1996 Sterman
 5,613,953 A 3/1997 Pohndorf
 5,690,648 A 11/1997 Fogarty

5,716,392 A 2/1998 Bourgeois
 5,728,151 A 3/1998 Garrison
 5,752,526 A 5/1998 Cosgrove
 5,776,110 A 7/1998 Guy
 5,814,076 A 9/1998 Brownlee
 5,823,946 A 10/1998 Chin
 5,871,532 A 2/1999 Schroepel
 5,895,414 A 4/1999 Sanchez-Zambrano
 5,904,711 A 5/1999 Flom
 5,941,819 A 8/1999 Chin
 5,944,732 A 8/1999 Raulerson
 5,951,518 A 9/1999 Licata
 6,024,704 A 2/2000 Meador
 6,032,079 A 2/2000 KenKnight
 6,099,547 A 8/2000 Gellman
 6,104,957 A 8/2000 Alo
 6,122,552 A 9/2000 Tockman
 6,159,198 A 12/2000 Gardeski
 6,228,052 B1 5/2001 Pohndorf
 6,283,127 B1 9/2001 Sterman
 6,324,414 B1 11/2001 Gibbons
 6,415,187 B1 7/2002 Kuzma
 6,445,954 B1 9/2002 Olive
 6,478,028 B1 11/2002 Paolitto
 6,544,247 B1 4/2003 Gardeski
 6,651,672 B2 11/2003 Roth
 6,706,052 B1 3/2004 Chin
 6,718,203 B2 4/2004 Weiner
 6,721,597 B1 4/2004 Bardy
 6,730,083 B2 5/2004 Freigang
 6,733,500 B2 5/2004 Kelley
 6,749,574 B2 6/2004 OKeefe
 6,770,070 B1 8/2004 Balbierz
 6,772,014 B2 8/2004 Coe
 6,836,687 B2 12/2004 Kelley
 6,866,044 B2 3/2005 Bardy
 6,868,291 B1 3/2005 Bonner
 6,887,229 B1 5/2005 Kurth
 6,890,295 B2 5/2005 Michels
 6,918,908 B2 7/2005 Bonner
 6,999,819 B2 2/2006 Swoyer
 7,033,326 B1 4/2006 Pianca
 7,050,851 B2 5/2006 Plombon
 7,069,083 B2 6/2006 Finch
 7,096,064 B2 8/2006 Deno
 7,117,039 B2 10/2006 Manning
 7,120,496 B2 10/2006 Bardy
 7,149,575 B2 12/2006 Ostroff
 7,191,015 B2 3/2007 Lamson
 7,195,637 B2 3/2007 Mika
 7,218,970 B2 5/2007 Ley
 7,229,450 B1 6/2007 Chitre
 7,272,448 B1 9/2007 Morgan
 7,288,096 B2 10/2007 Chin
 7,316,667 B2 1/2008 Lindstrom
 7,319,905 B1 1/2008 Morgan
 7,322,960 B2 1/2008 Yamamoto
 7,369,899 B2 5/2008 Malinowski
 7,373,207 B2 5/2008 Lattouf
 7,389,134 B1 6/2008 Karicherla
 7,398,781 B1 7/2008 Chin
 7,450,997 B1 11/2008 Pianca
 7,499,758 B2 3/2009 Cates
 7,515,969 B2* 4/2009 Tockman A61N 1/0587
 7,539,542 B1 5/2009 Malinowski
 7,627,375 B2 12/2009 Bardy
 7,655,014 B2 2/2010 Ko
 7,736,330 B2 6/2010 Bardy
 7,751,885 B2 7/2010 Bardy
 7,761,150 B2 7/2010 Ghanem
 7,765,014 B2 7/2010 Eversull
 7,801,622 B2 9/2010 Camps
 7,837,671 B2 11/2010 Eversull
 7,846,088 B2 12/2010 Ness
 7,850,610 B2 12/2010 Ferek-Petric
 7,890,191 B2 2/2011 Rutten
 7,908,015 B2 3/2011 Lazeroms
 7,930,028 B2 4/2011 Lang

607/122

(56)

References Cited

U.S. PATENT DOCUMENTS

7,930,040	B1	4/2011	Kelsch	2007/0150023	A1	6/2007	Ignagni
7,967,833	B2	6/2011	Sterman	2007/0179388	A1	8/2007	Larik
7,983,765	B1	7/2011	Doan	2007/0208402	A1	9/2007	Helland
8,060,207	B2	11/2011	Wallace	2007/0249992	A1	10/2007	Bardy
8,065,020	B2	11/2011	Ley	2008/0046056	A1	2/2008	OConnor
8,066,702	B2	11/2011	Rittman, III	2008/0103575	A1	5/2008	Gerber
8,090,451	B2	1/2012	Tyson, Jr.	2008/0183230	A1	7/2008	Kemmetmueller
8,155,755	B2	4/2012	Flynn	2008/0243219	A1	10/2008	Malinowski
8,157,813	B2	4/2012	Ko	2008/0269716	A1	10/2008	Bonde
8,260,436	B2	9/2012	Gerber	2008/0294217	A1	11/2008	Lian
8,280,527	B2	10/2012	Eckerdal	2008/0300644	A1	12/2008	Sathaye
8,332,036	B2	12/2012	Hastings	2009/0054947	A1	2/2009	Bourn
8,340,779	B2	12/2012	Harris	2009/0069803	A1	3/2009	Starkebaum
8,355,786	B2	1/2013	Malinowski	2009/0157091	A1	6/2009	Buysman
8,386,052	B2	2/2013	Harris	2009/0209970	A1	8/2009	Tanaka
8,394,079	B2	3/2013	Drake	2009/0222021	A1	9/2009	Chang
8,435,208	B2	5/2013	Bardy	2009/0259283	A1	10/2009	Brandt
8,442,620	B2	5/2013	Silipo	2009/0264780	A1	10/2009	Schilling
8,452,421	B2	5/2013	Thenuwara	2009/0270962	A1	10/2009	Yang
8,457,742	B2	6/2013	Jacobson	2009/0326346	A1	12/2009	Kracker
8,478,424	B2	7/2013	Tronnes	2010/0016935	A1	1/2010	Strandberg
8,478,426	B2	7/2013	Barker	2010/0030227	A1	2/2010	Kast
8,478,431	B2	7/2013	Griswold	2010/0030228	A1	2/2010	Havel
8,532,789	B2	9/2013	Smits	2010/0056858	A1	3/2010	Mokelke
8,594,809	B2	11/2013	Yang	2010/0082087	A1	4/2010	Silipo
8,886,311	B2	11/2014	Anderson	2010/0094252	A1	4/2010	Wengreen
9,622,778	B2	4/2017	Wengreen	2010/0113963	A1	5/2010	Smits
9,636,505	B2	5/2017	Sanghera	2010/0125194	A1	5/2010	Bonner
9,707,389	B2	7/2017	McGeehan	2010/0137879	A1	6/2010	Ko
10,130,824	B2	11/2018	Grinberg	2010/0152747	A1	6/2010	Padiy
10,137,295	B2	11/2018	Marshall	2010/0152798	A1	6/2010	Sanghera
10,471,267	B2	11/2019	Thompson-Nauman	2010/0185268	A1	7/2010	Fowler
2002/0042629	A1	4/2002	Bardy	2010/0211064	A1	8/2010	Mahapatra
2002/0120294	A1	8/2002	Kroll	2010/0217298	A1	8/2010	Bardy
2003/0045904	A1	3/2003	Bardy	2010/0217301	A1	8/2010	Bardy
2003/0074041	A1	4/2003	Parry	2010/0241189	A1	9/2010	Dobak
2003/0088278	A1	5/2003	Bardy	2010/0305428	A1	12/2010	Bonner
2003/0114905	A1	6/2003	Kuzma	2010/0318098	A1	12/2010	Lund
2003/0114906	A1	6/2003	Booker	2010/0324579	A1	12/2010	Bardy
2003/0114908	A1	6/2003	Flach	2011/0009933	A1	1/2011	Barker
2003/0120264	A1	6/2003	Lattouf	2011/0024491	A1	2/2011	Jamali
2003/0130581	A1	7/2003	Salo	2011/0066185	A1	3/2011	Wotton, III
2003/0187458	A1	10/2003	Carlson	2011/0077708	A1	3/2011	Ostroff
2004/0059348	A1	3/2004	Geske	2011/0125163	A1	5/2011	Rutten
2004/0088035	A1	5/2004	W Guent	2011/0152706	A1	6/2011	Christopherson
2004/0102829	A1	5/2004	Bonner	2011/0178566	A1	7/2011	Stahmann
2004/0158185	A1	8/2004	Moran	2011/0210156	A1	9/2011	Smith
2004/0210293	A1	10/2004	Bardy	2011/0224680	A1	9/2011	Barker
2004/0215240	A1	10/2004	Lovett	2011/0224681	A1	9/2011	McDonald
2004/0230282	A1	11/2004	Cates	2011/0230906	A1	9/2011	Modesitt
2004/0236396	A1	11/2004	Coe	2011/0257660	A1	10/2011	Jones
2005/0027328	A1	2/2005	Greenstein	2012/0016377	A1	1/2012	Geroy
2005/0049663	A1	3/2005	Harris	2012/0029335	A1	2/2012	Sudam
2005/0131505	A1	6/2005	Yokoyama	2012/0037291	A1	2/2012	Goolishian
2005/0165324	A1*	7/2005	Receveur A61B 34/20 600/549	2012/0078266	A1	3/2012	Tyson
2005/0192639	A1	9/2005	Bardy	2012/0089153	A1	4/2012	Christopherson
2005/0288731	A1	12/2005	Shames	2012/0097174	A1	4/2012	Spotnitz
2005/0288758	A1	12/2005	Jones	2012/0109250	A1	5/2012	Cates
2006/0041295	A1	2/2006	Osycka	2012/0123496	A1	5/2012	Schotzko
2006/0089699	A1	4/2006	Imran	2012/0191106	A1	7/2012	Ko
2006/0116746	A1	6/2006	Chin	2012/0209283	A1	8/2012	Zhu
2006/0122676	A1	6/2006	Ko	2012/0209298	A1	8/2012	McClurg
2006/0129202	A1	6/2006	Armstrong	2013/0006326	A1	1/2013	Ackermann
2006/0136004	A1	6/2006	Cowan	2013/0041345	A1	2/2013	Kilcoin
2006/0161205	A1	7/2006	Mitrani	2013/0103049	A1	4/2013	Bonde
2006/0241711	A1	10/2006	Sathaye	2013/0158564	A1	6/2013	Harris
2006/0247672	A1	11/2006	Vidlund	2013/0178711	A1	7/2013	Avneri
2006/0247753	A1	11/2006	Wenger	2013/0226266	A1	8/2013	Murtonen
2006/0253181	A1	11/2006	Schulman	2013/0237781	A1	9/2013	Gym
2006/0266368	A1	11/2006	Heintz	2013/0238067	A1	9/2013	Baudino
2007/0023947	A1	2/2007	Ludwig	2013/0296880	A1	11/2013	Kelley
2007/0088394	A1	4/2007	Jacobson	2013/0338707	A1	12/2013	Killion
2007/0100409	A1	5/2007	Worley	2014/0005755	A1	1/2014	Wolf, II
2007/0150015	A1	6/2007	Zhang	2014/0018872	A1	1/2014	Siejko
				2014/0180273	A1	6/2014	Nair
				2014/0257421	A1	9/2014	Sanghera
				2014/0330208	A1	11/2014	Christie
				2014/0330248	A1	11/2014	Thompson-Nauman
				2014/0330287	A1	11/2014	Thompson-Nauman

(56)

References Cited

U.S. PATENT DOCUMENTS

2014/0330325 A1 11/2014 Thompson-Nauman
 2014/0330326 A1 11/2014 Thompson-Nauman
 2014/0330327 A1 11/2014 Thompson-Nauman
 2014/0330328 A1 11/2014 Christie
 2014/0330329 A1 11/2014 Thompson-Nauman
 2014/0330331 A1 11/2014 Thompson-Nauman
 2015/0013689 A1 1/2015 Shackelford
 2015/0051612 A1 2/2015 Schmidt
 2015/0051615 A1 2/2015 Schmidt
 2015/0088155 A1 3/2015 Stahmann
 2015/0133954 A1* 5/2015 Seifert A61N 1/0563
 606/129
 2015/0142069 A1 5/2015 Sambelashvili
 2015/0157497 A1 6/2015 Hufford
 2015/0223906 A1 8/2015 O'Neill
 2015/0313633 A1* 11/2015 Gross A61B 1/00135
 606/185
 2015/0328473 A1 11/2015 Bodner
 2016/0051159 A1 2/2016 Mazaeva
 2016/0067478 A1 3/2016 McGeehan
 2016/0067479 A1 3/2016 Marcovecchio
 2016/0067480 A1 3/2016 Sanghera
 2016/0067488 A1 3/2016 Sanghera
 2016/0144192 A1 5/2016 Sanghera
 2016/0175581 A1 6/2016 Gordon
 2016/0184047 A1 6/2016 Weir
 2017/0224995 A1 8/2017 Sanghera
 2017/0304019 A1 10/2017 Sanghera

2017/0304634 A1 10/2017 Sanghera
 2018/0021572 A1 1/2018 McGeehan
 2018/0050199 A1 2/2018 Sanghera

FOREIGN PATENT DOCUMENTS

EP 2346419 7/2011
 EP 2967644 1/2016
 EP 2994193 3/2016
 WO 2002026315 A1 4/2002
 WO 2006115772 A2 11/2006
 WO 2013163267 A1 10/2013
 WO 2015143327 9/2015

OTHER PUBLICATIONS

Brown, Charles G., et. al. 'Placement Accuracy of Percutaneous Transthoracic Pacemakers.' The American Journal of Emergency Medicine 3.3 (1985): 193-98.
 Nagdev, Arun, and Daniel Mantuani. 'A Novel In-plane Technique for Ultrasound-guided Pericardiocentesis.' The American Journal of Emergency Medicine 31.9 (2013): 1424.e6-1424.e9.
 Jai, N. V., et. al. 'Relation of Internal Thoracic Artery to Lateral Sternal Border and Its Significance in Clinical Procedures.' International Journal of Biological & Medical Research 4.4 (2013): 3633-636.
 PCT/US2017/041265; International Search Report and Written Opinion dated Sep. 25, 2017.

* cited by examiner

100

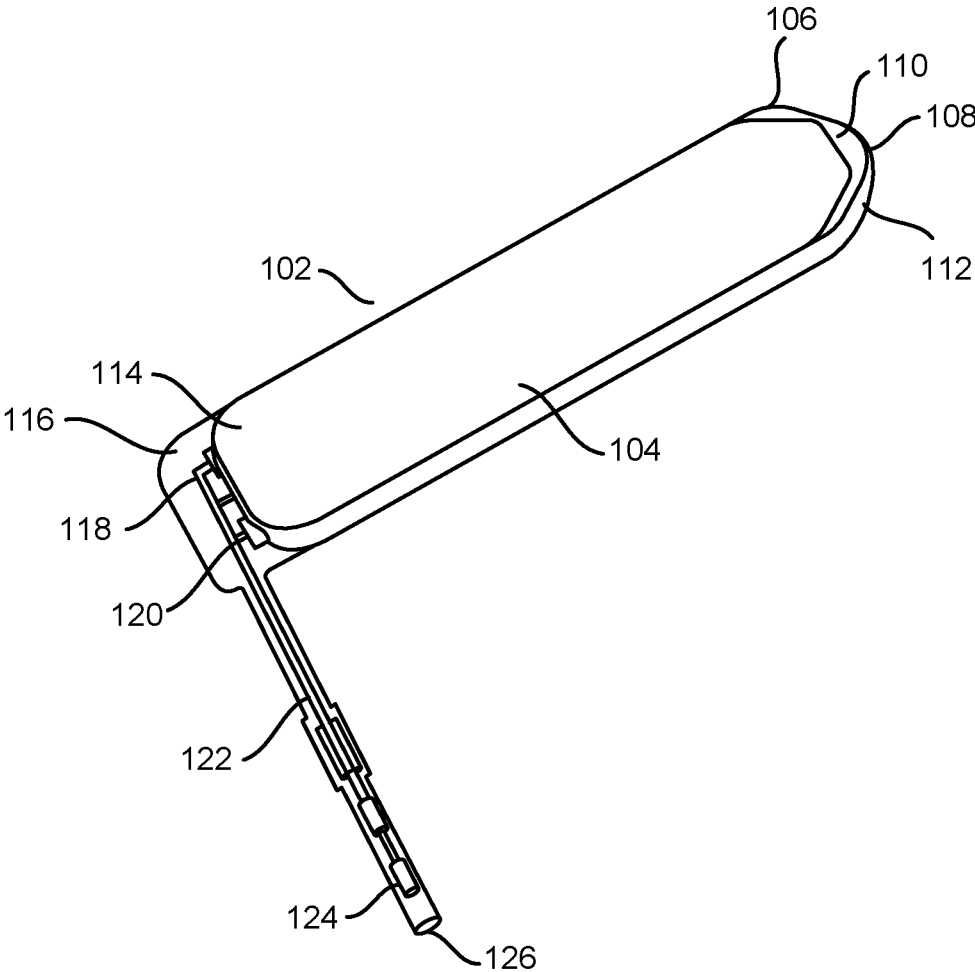

FIG. 1

200

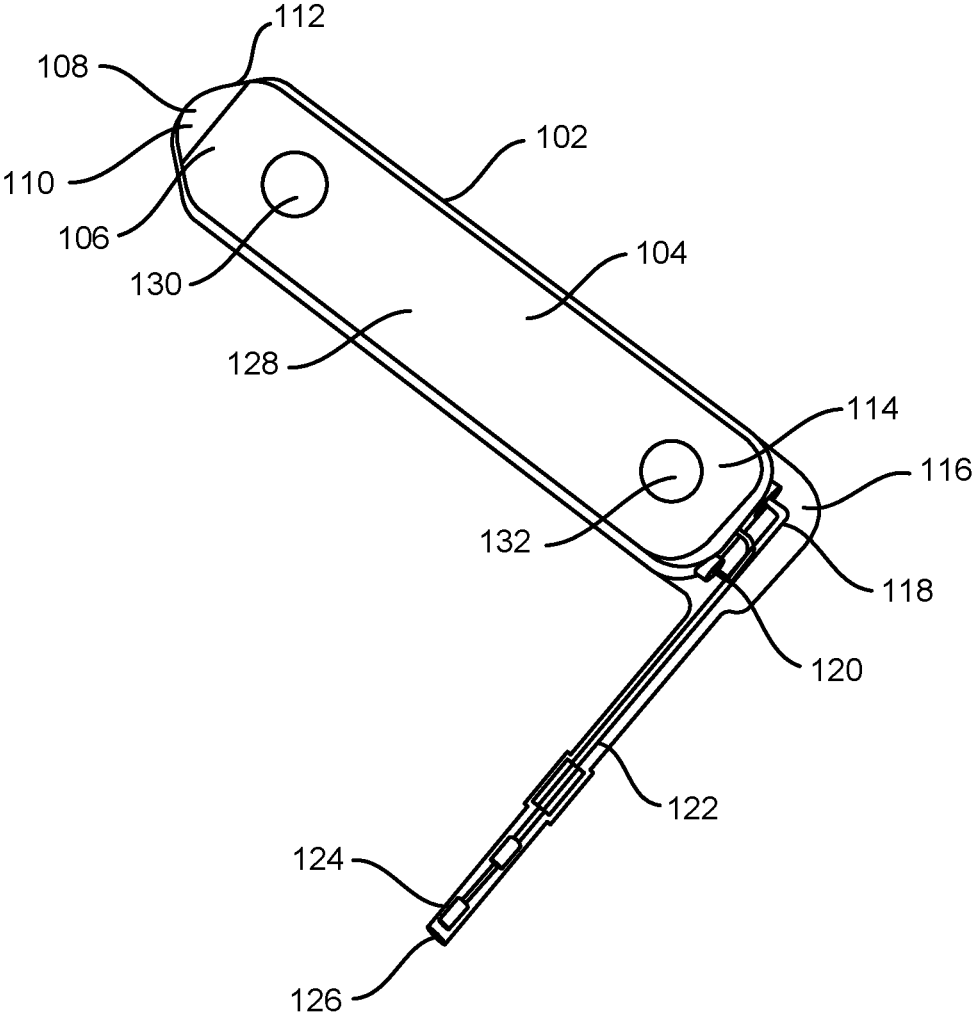

FIG. 2

300

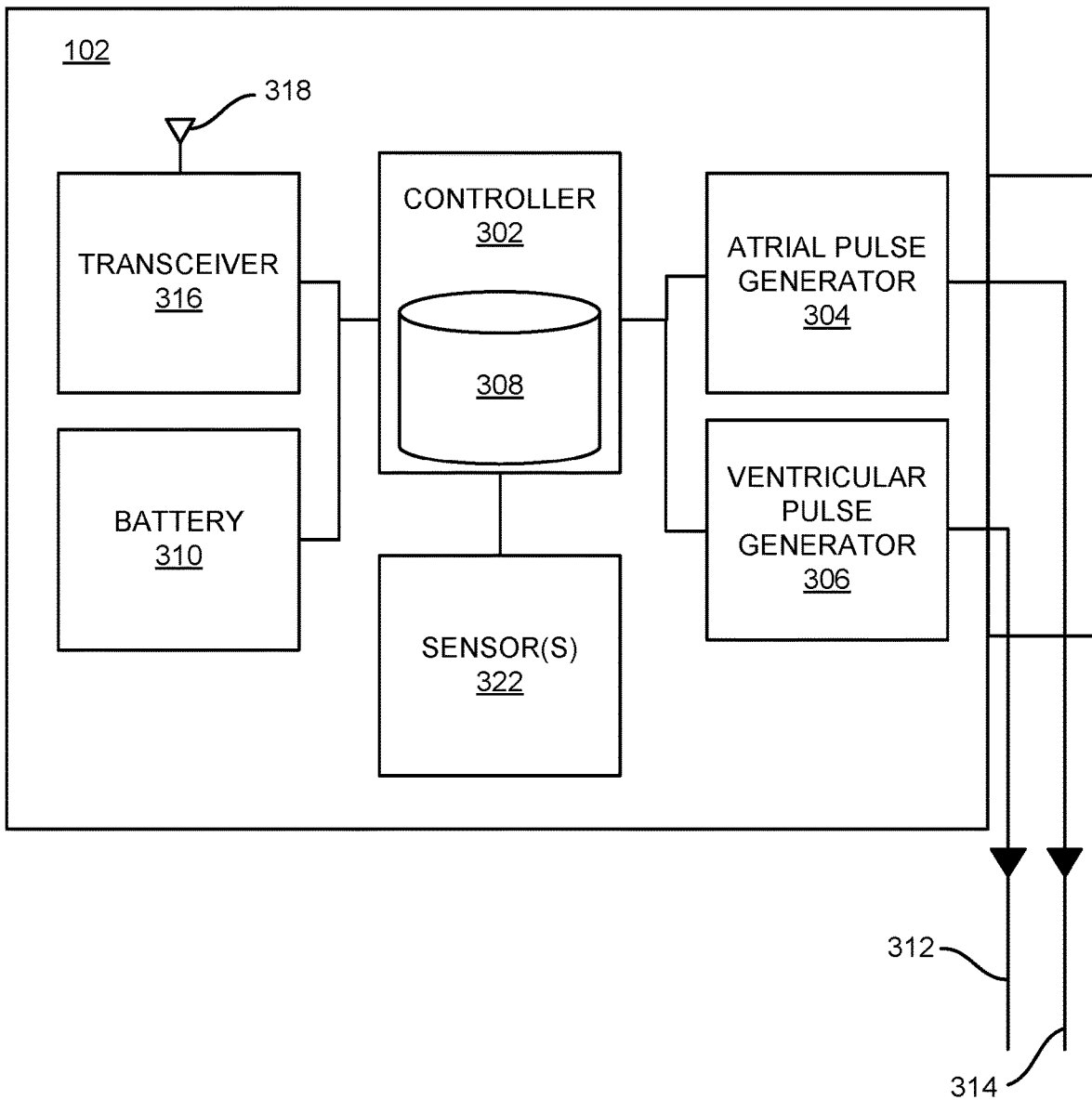
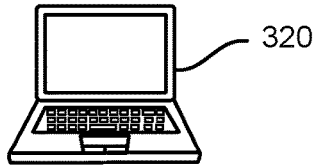

FIG. 3

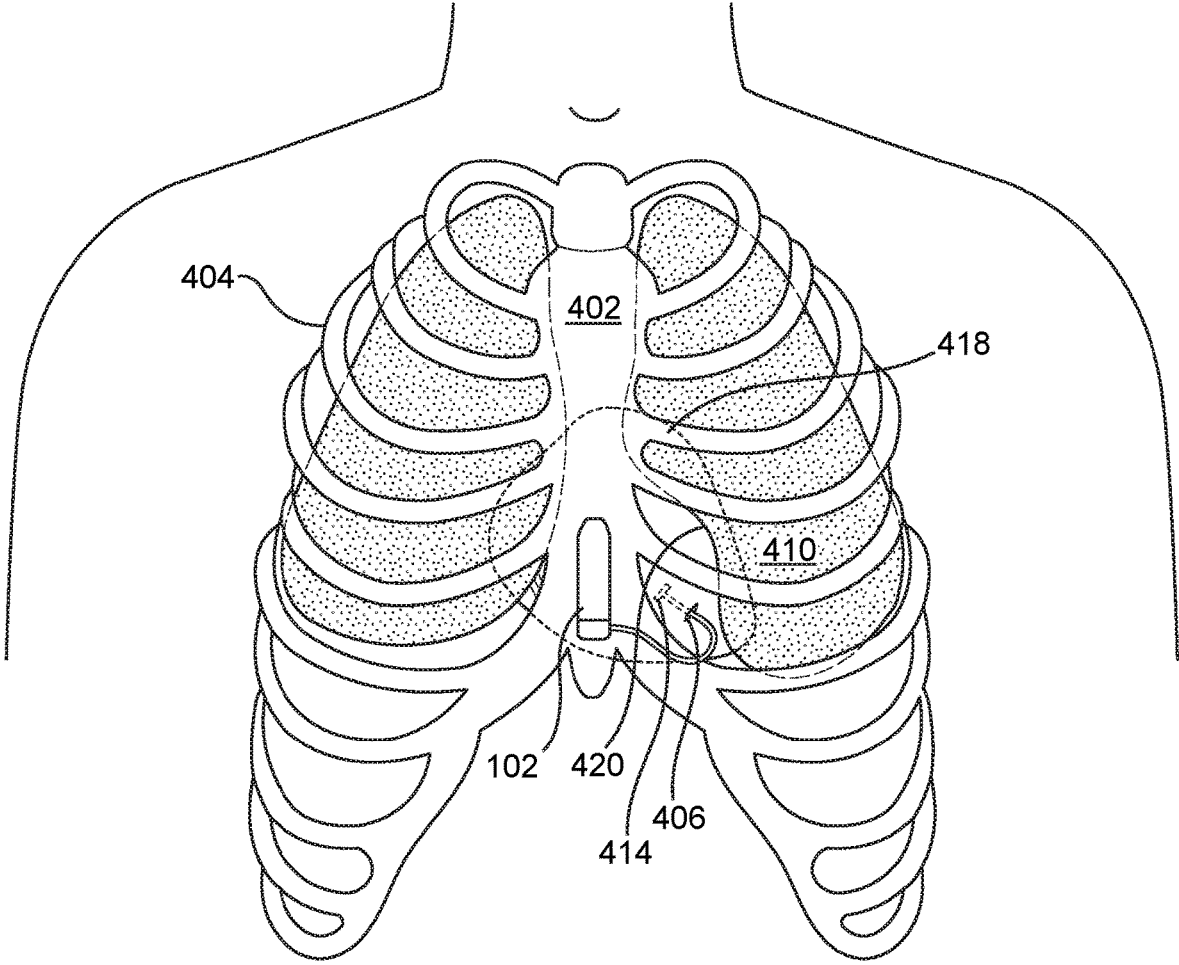

FIG. 4A

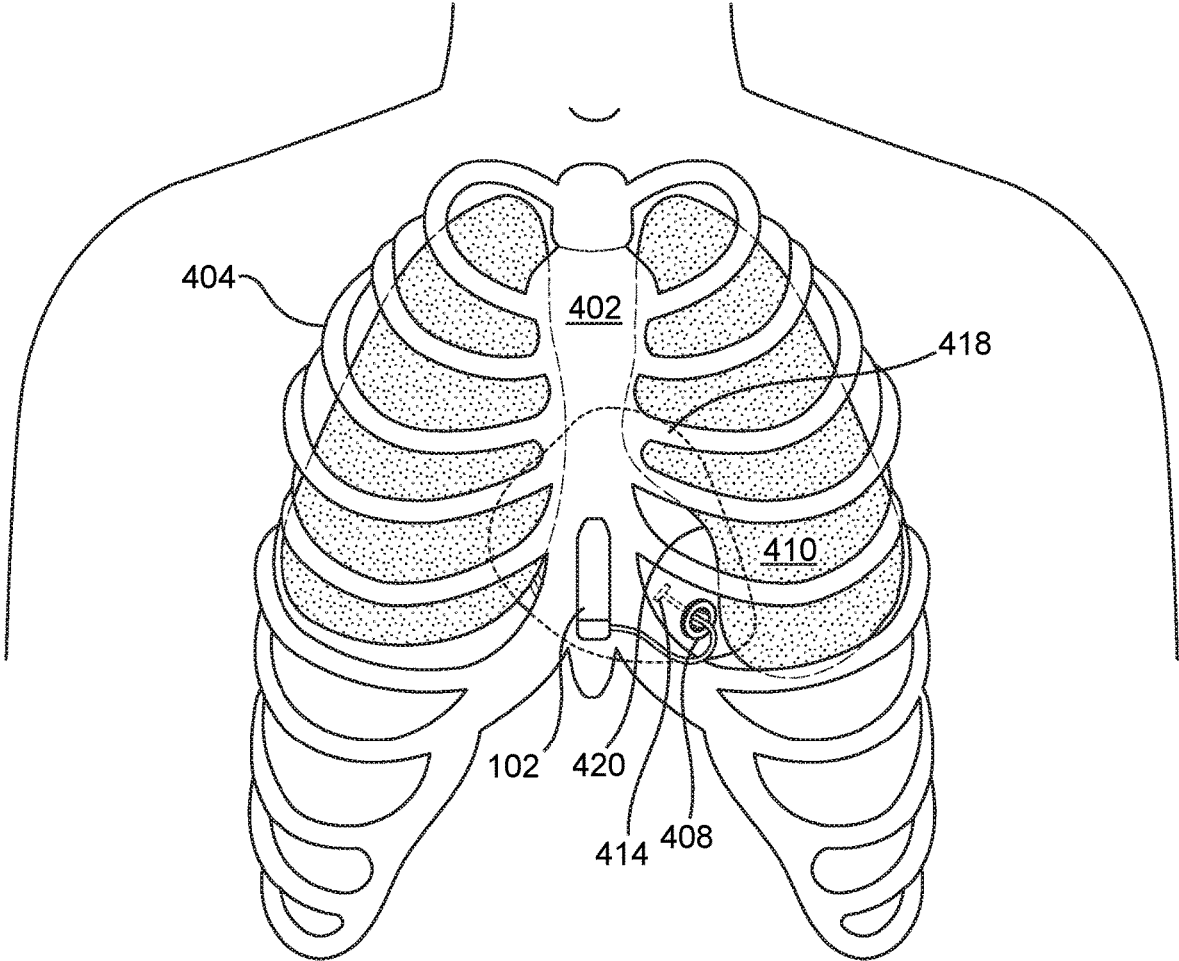

FIG. 4B

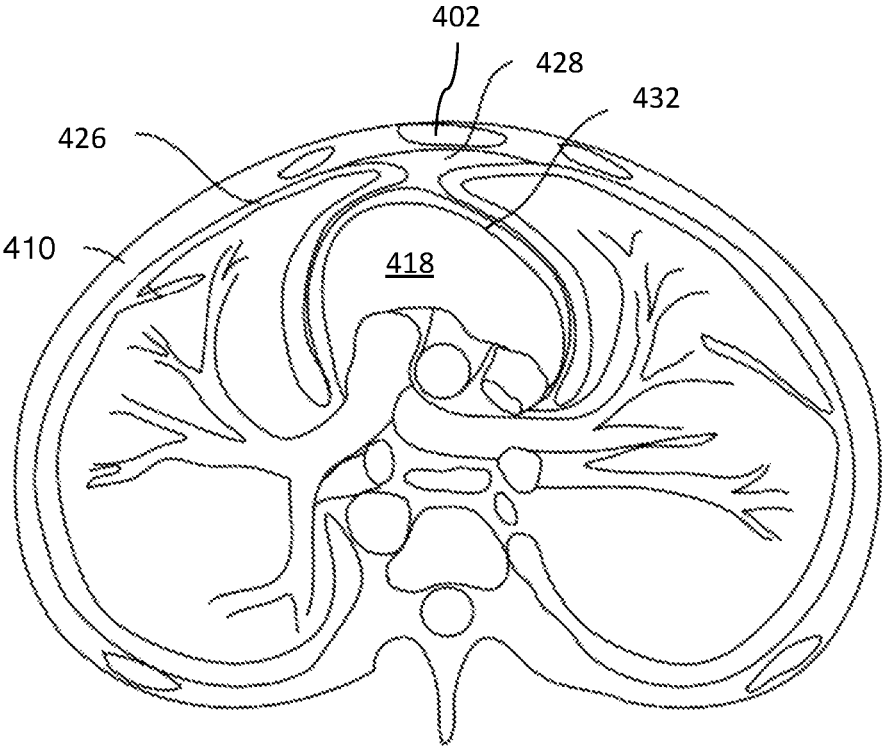

FIG. 4C

500

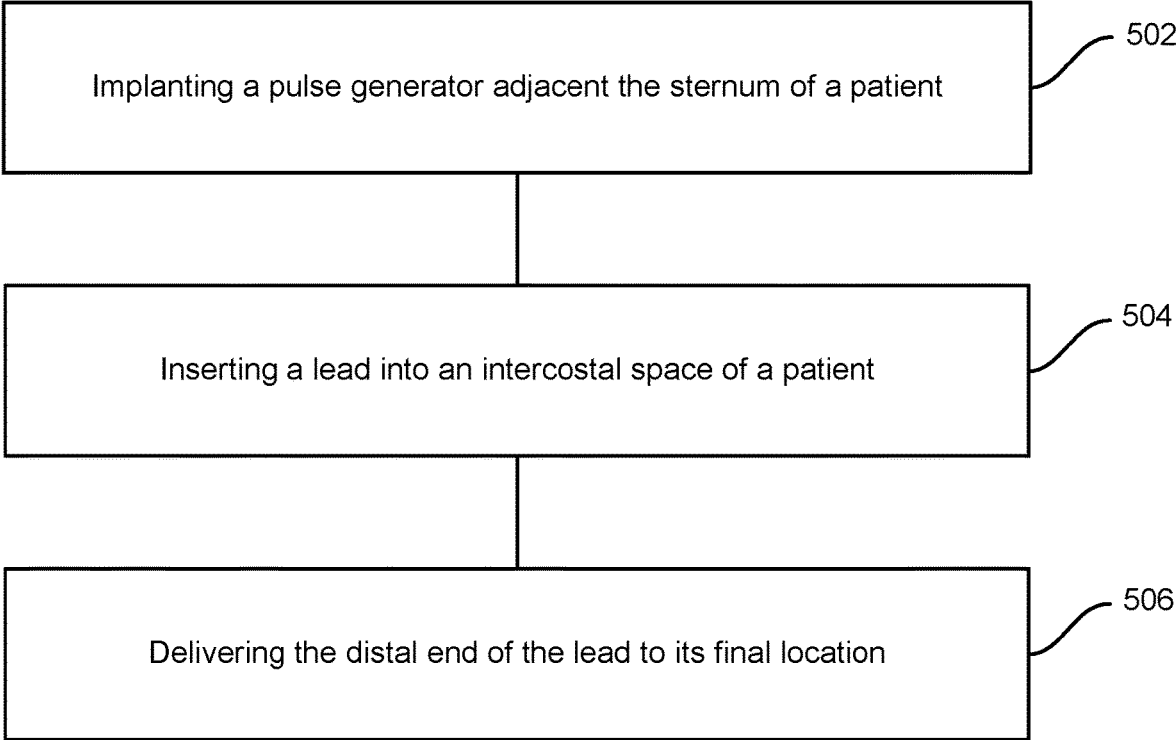

FIG. 5

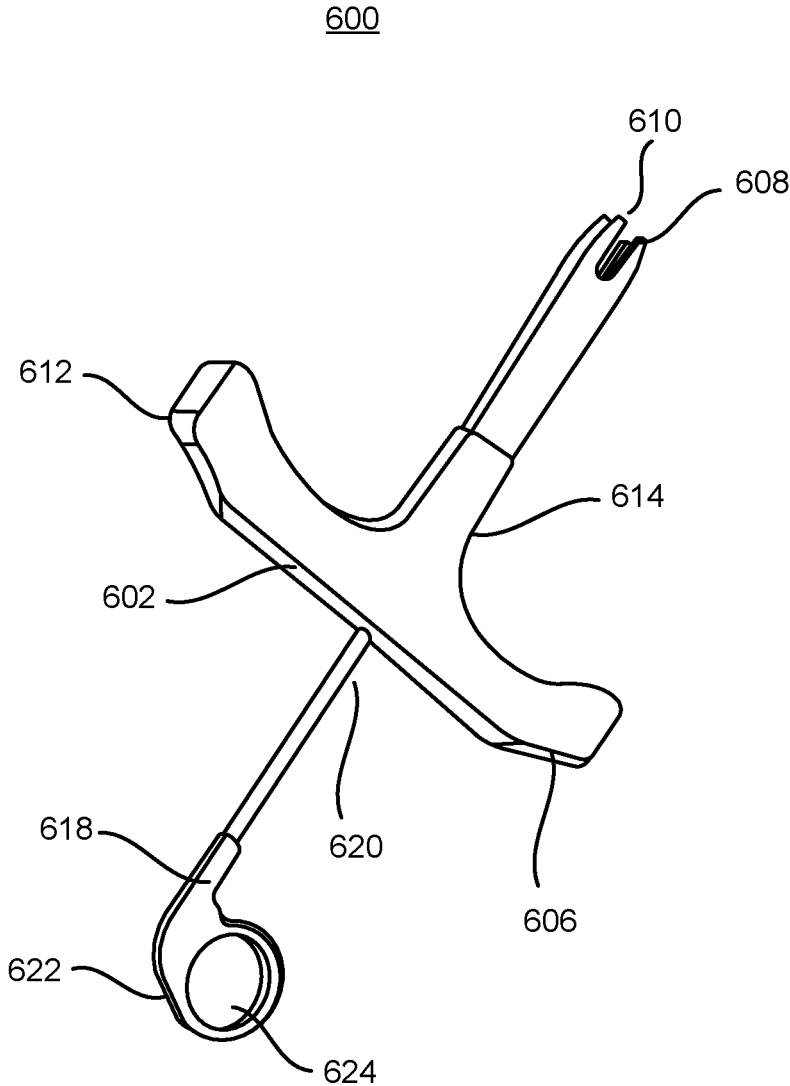

FIG. 6A

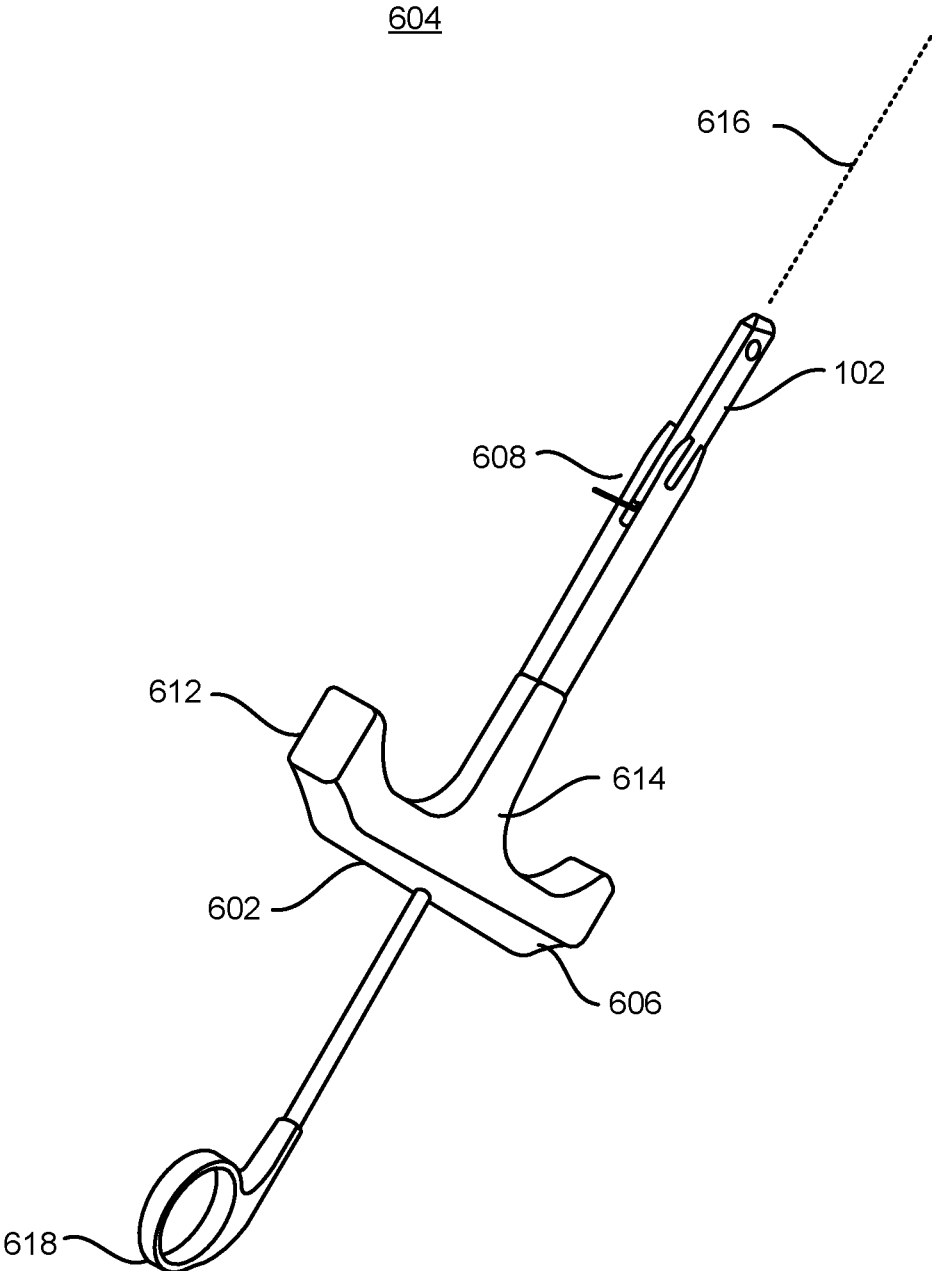

FIG. 6B

700

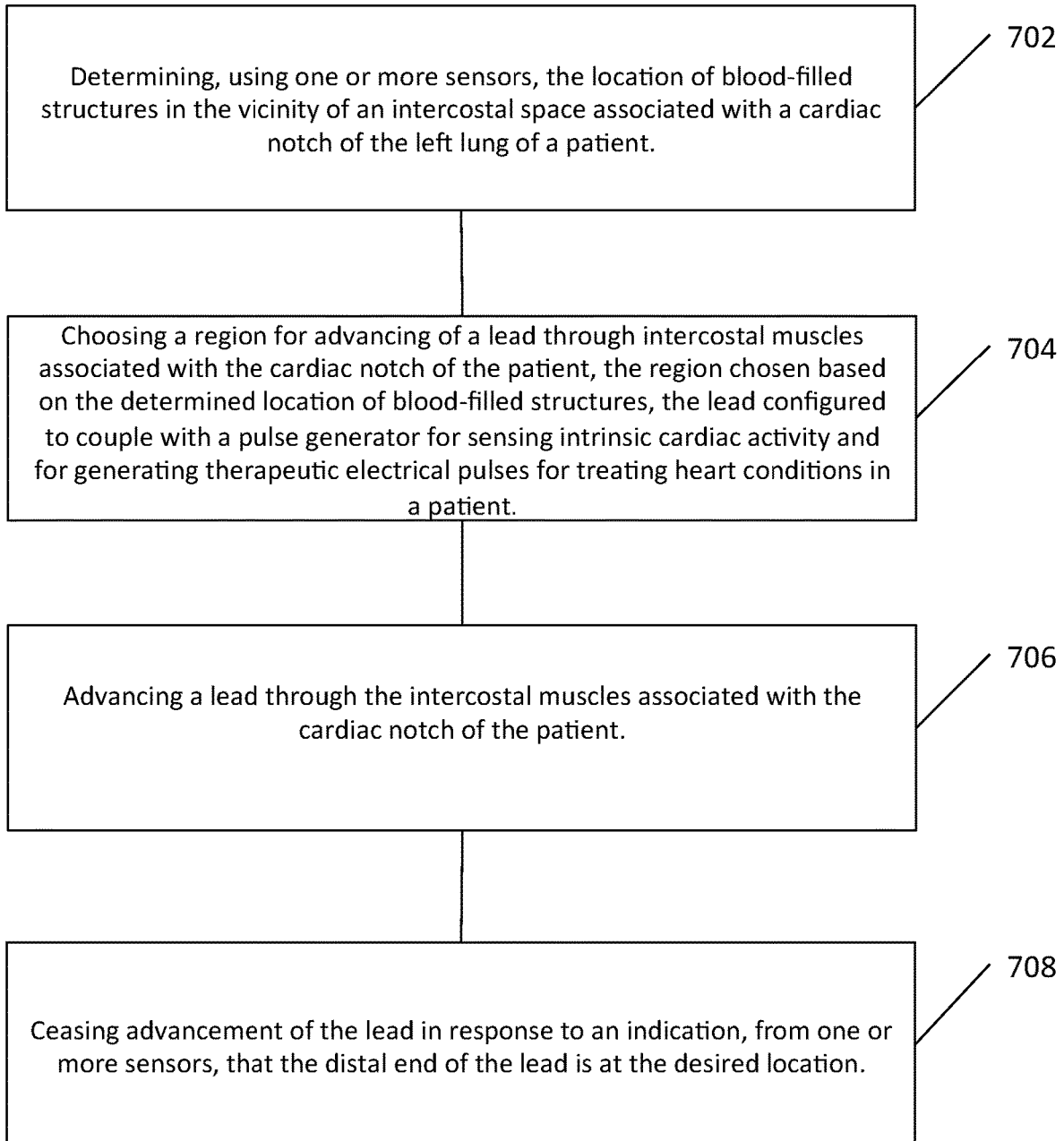

FIG. 7

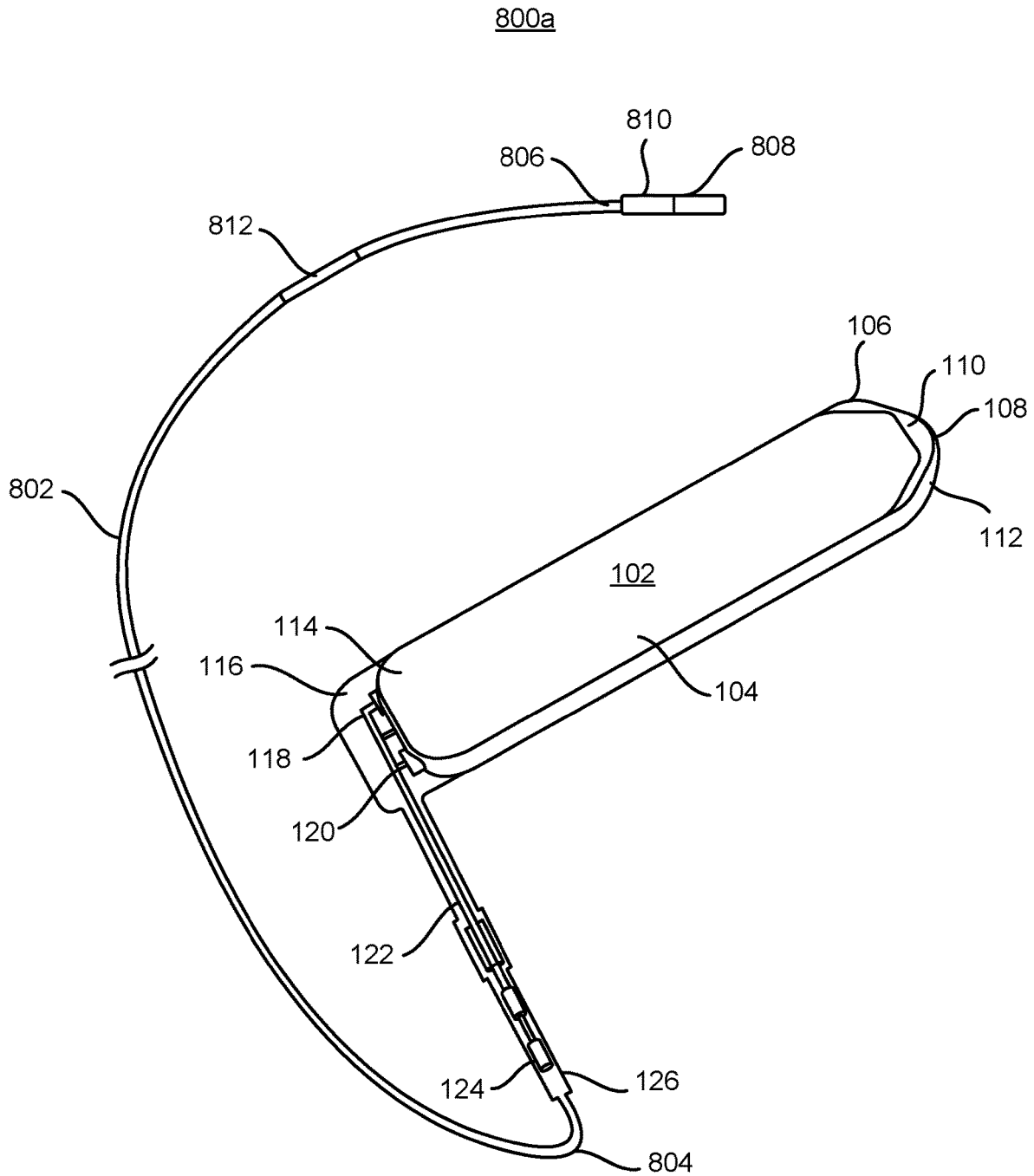

FIG. 8A

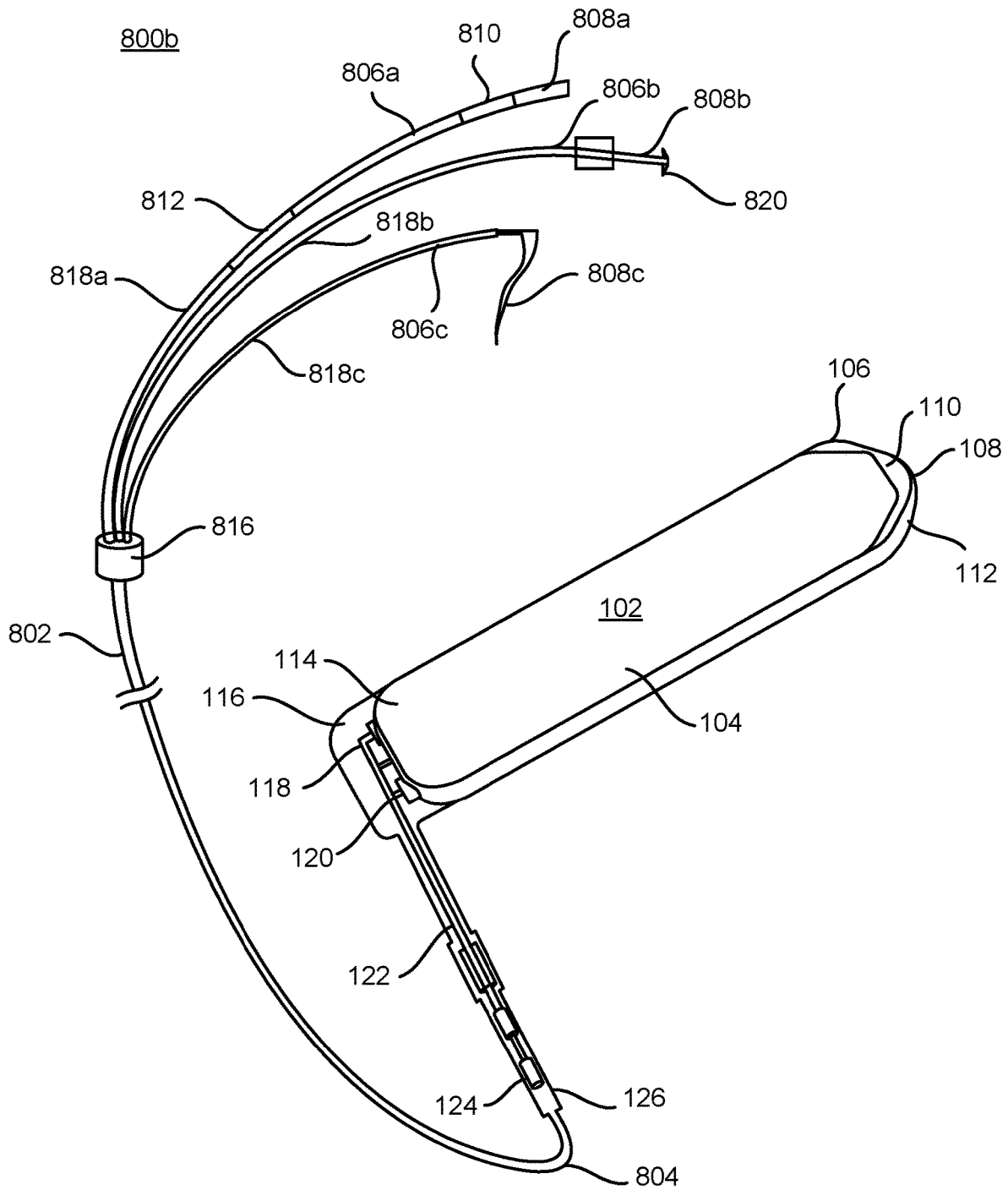

FIG. 8B

900

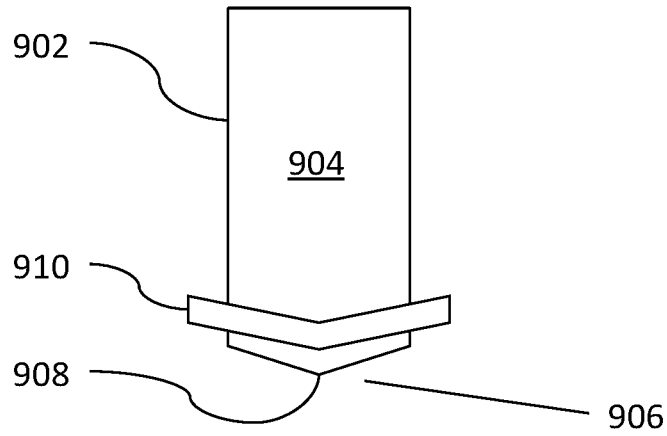

FIG. 9A

912

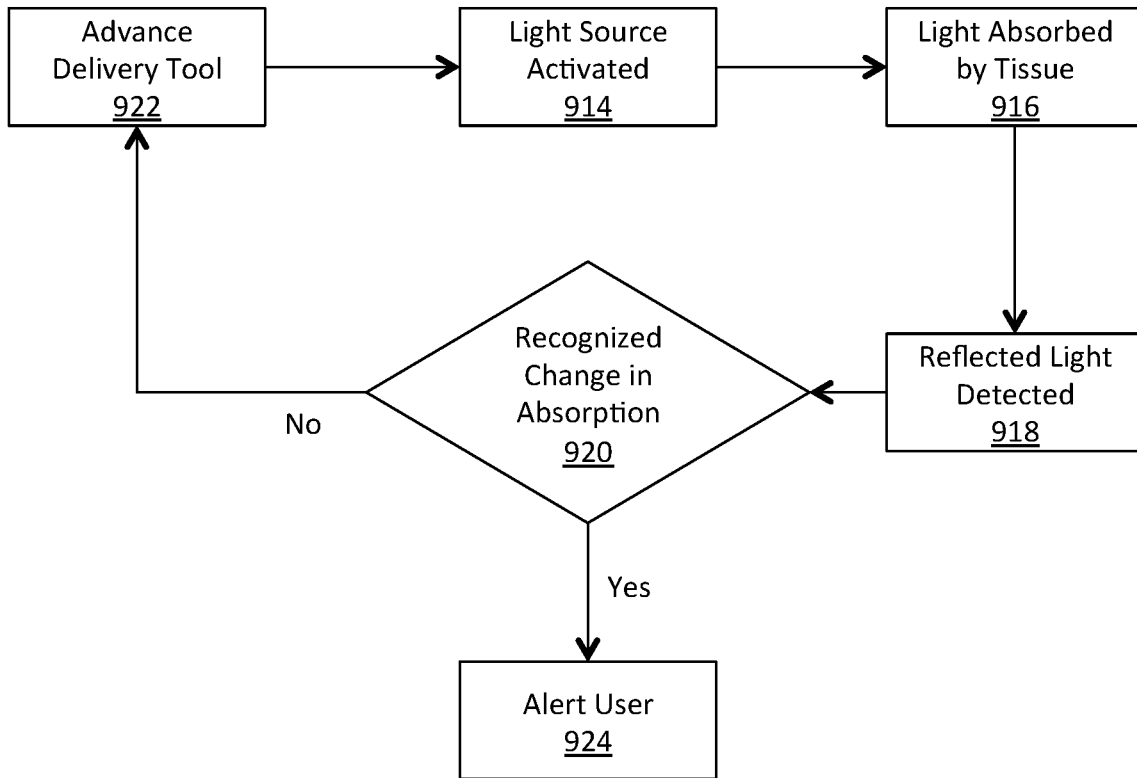

FIG. 9B

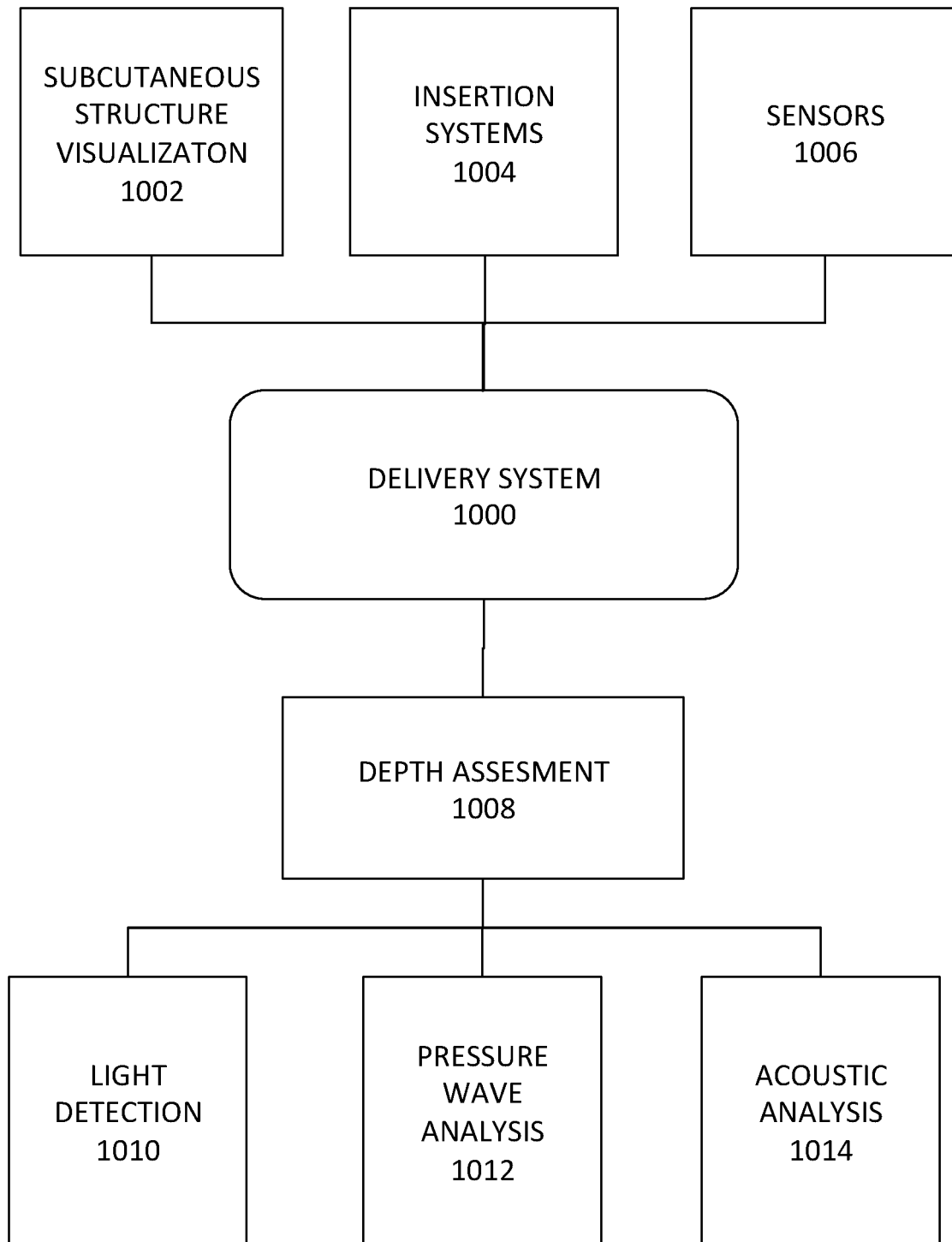

FIG. 10

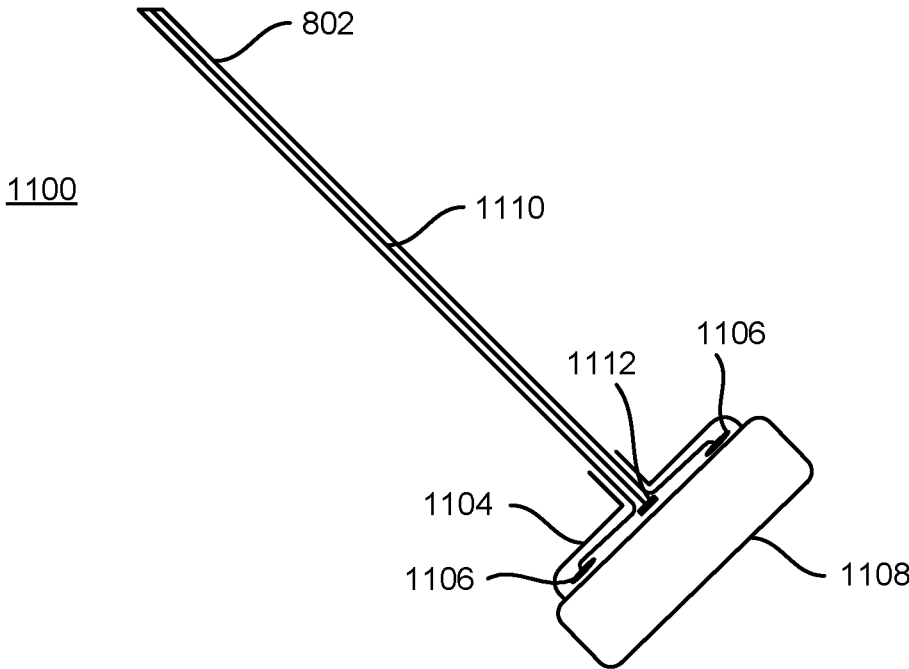

FIG. 11A

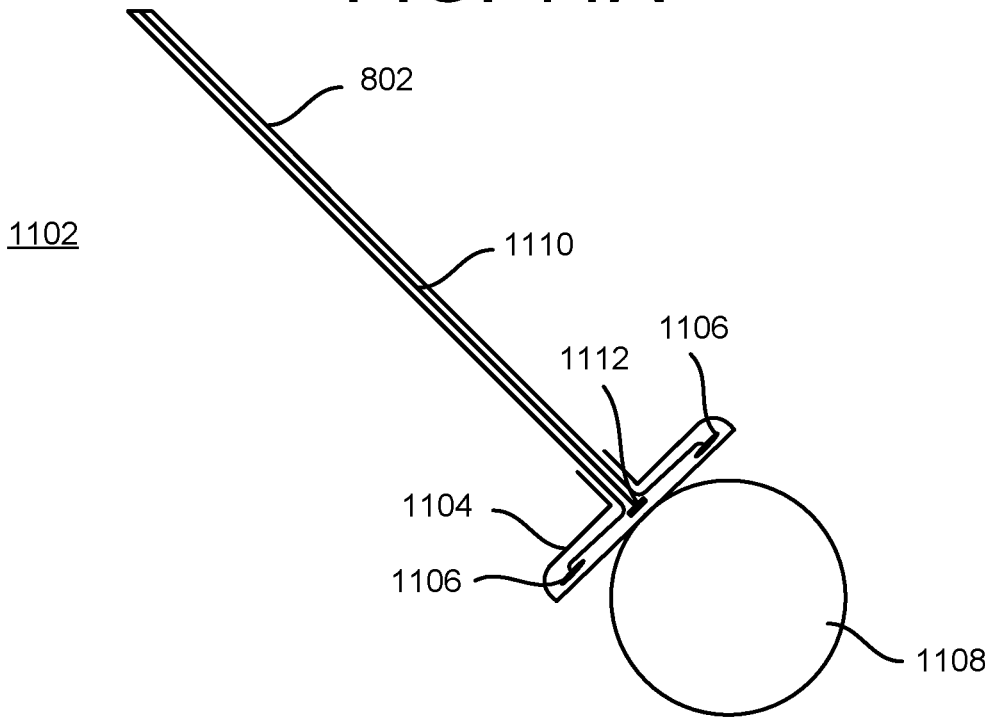

FIG. 11B

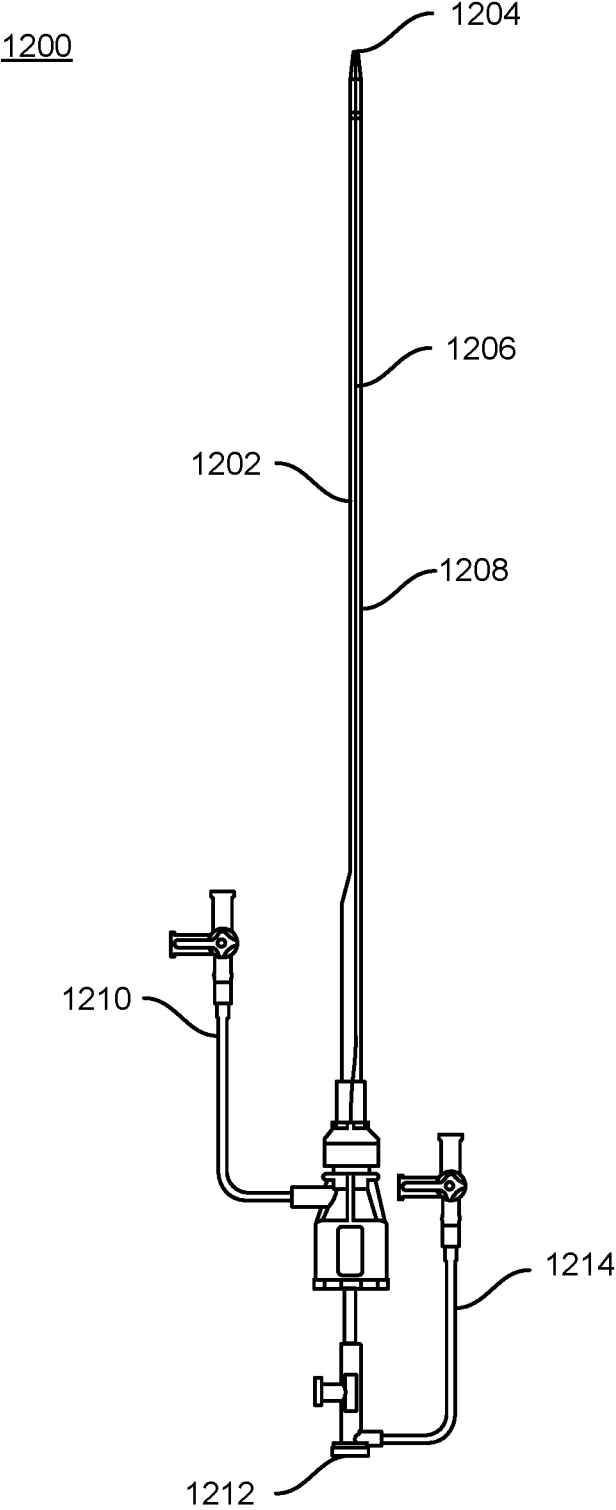

FIG. 12

1300

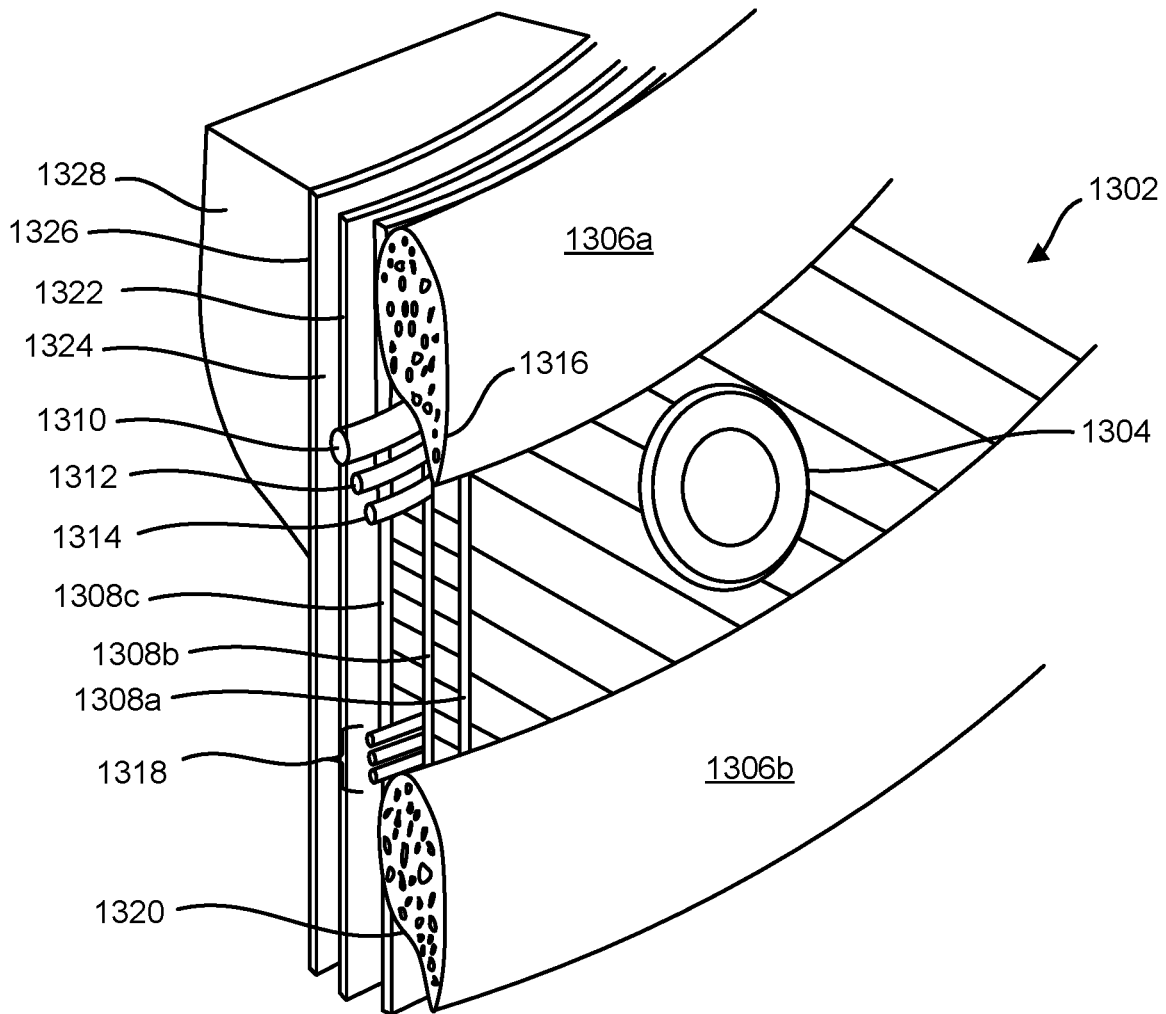

FIG. 13

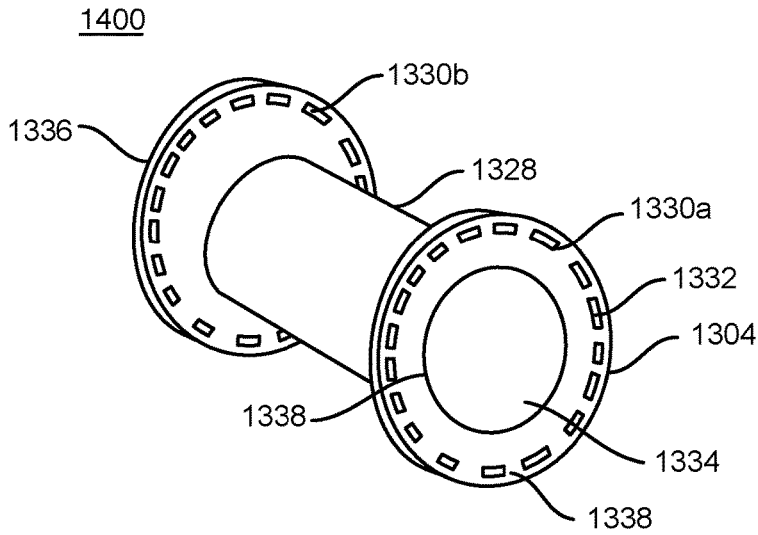

FIG. 14

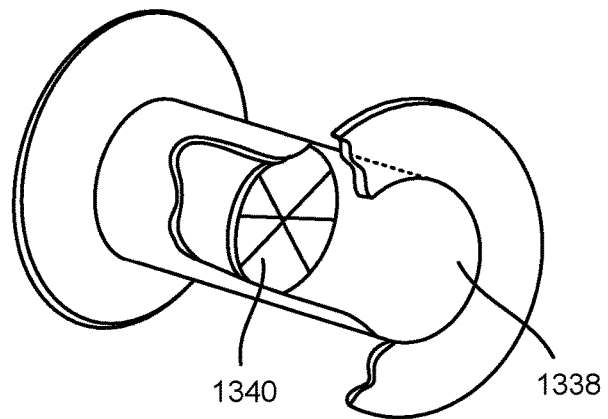

FIG. 15

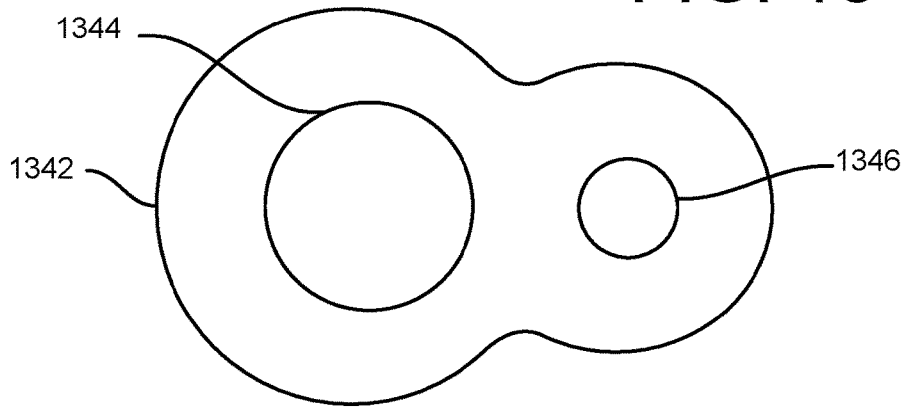

FIG. 16

**DELIVERY SYSTEM FOR CARDIAC
PACING****CROSS-REFERENCE TO RELATED
APPLICATIONS**

This application is a continuation of and claims priority to and the benefit of U.S. patent application Ser. No. 14/846,648, titled Delivery System for Cardiac Pacing, filed Sep. 4, 2015, which claims priority to and the benefit of U.S. Provisional Patent Application No. 62/045,683, titled Cardiac Pacemaker System having Intracostal Electrodes, filed Sep. 4, 2014, U.S. Provisional Patent Application No. 62/083,516 titled Implantable Medical Device with Pacing Therapy, filed Nov. 24, 2014, and U.S. Provisional Patent Application No. 62/146,569 titled Delivery Systems and Implantable Leads for Intracostal Pacing, filed Apr. 13, 2015, the disclosures of each are incorporated herein by reference in their entirety.

TECHNICAL FIELD

The subject matter described herein relates to devices, systems and methods for cardiac pacing.

BACKGROUND

An artificial pacemaker is a medical device that helps control abnormal heart rhythms. A pacemaker uses electrical pulses to prompt the heart to beat at a normal rate. The pacemaker may speed up a slow heart rhythm, control a fast heart rhythm, and coordinate the chambers of the heart. The implantable portions of a pacemaker system generally comprise three main components: a pulse generator, one or more wires called leads, and electrodes found on each lead. The pulse generator produces the electrical signals that make the heart beat. Most pulse generators also have the capability to receive and respond to signals that are sent by the heart. Leads are insulated flexible wires that conduct electrical signals to the heart from the pulse generator. The leads may also relay signals from the heart to the pulse generator. One end of the lead is attached to the pulse generator and the electrode end of the lead is positioned on or in the heart.

SUMMARY

In one aspect, a delivery device for installing a medical device in a patient is described. The delivery device may comprise a body portion. The body portion may have a proximal end and a distal end. The distal end may have a chisel-shaped tip. The delivery device may have a receptacle disposed in the distal end of the body portion. The receptacle can be configured to receive a medical device for implanting into a patient with the medical device contained within the receptacle. A handle may be disposed at the proximal end of the body portion. The handle may be configured to facilitate advancement of the proximal end of the body portion into the patient.

In some variations, one or more of the following features may optionally be included in any feasible combination. The body portion may be configured to accommodate a port assembly contiguously attached to the medical device. The medical device may be a pulse generator. The delivery device may comprise a plunger configured to push the medical device out of the receptacle.

In another aspect a cardiac pacing system is described. The cardiac pacing system may comprise a pulse generator.

The pulse generator may include a housing. The pulse generator may be configured to generate therapeutic electric pulses. The cardiac pacing system may comprise at least one lead receptacle. The at least one lead receptacle may be configured to be placed within an intercostal space of a patient. The cardiac pacing system may comprise at least one lead may be configured to electrically couple with the pulse generator and transmit the therapeutic electric pulses generated by the pulse generator. The at least one lead may comprise a lead body. The lead body may be configured to transmit the therapeutic electrical pulses between a distal end and a proximal end of the lead body. The at least one lead may comprise at least one accelerometer disposed at the distal end of the lead body. The at least one accelerometer may be configured to detect movement of the distal end of the lead as it is advanced into the patient.

In some variations, one or more of the following features may optionally be included in any feasible combination. The accelerometer may be configured to measure a pressure wave emitted by a blood-filled vessel of the patient.

In another aspect a cardiac pacing system is described. The cardiac pacing system may comprise a pulse generator. The pulse generator may include a housing. The pulse generator may be configured to generate therapeutic electric pulses. The cardiac pacing system may comprise at least one lead receptacle configured to be placed within an intercostal space of a patient. The cardiac pacing system may comprise at least one lead. The at least one lead may be configured to electrically couple with the pulse generator. The at least one lead may be configured to transmit the therapeutic electric pulses generated by the pulse generator. The at least one lead may comprise a lead body. The lead body may be configured to transmit the therapeutic electric pulses between a distal end and a proximal end of the lead body. The lead may comprise at least one sensor disposed at the distal end of the lead body. The at least one sensor may be configured to monitor physiological characteristics of the patient when the distal end of the lead is advanced through an intercostal space associated with a cardiac notch of the left lung of the patient.

In some variations, one or more of the following features may optionally be included in any feasible combination. The at least one sensor may comprises at least one accelerometer. The at least one accelerometer may be configured to detect movement of the distal end of the cardiac lead as it is advanced into the patient.

The at least one sensor may comprise a light source. The light source may be configured to emit photons having a wavelength that is readily absorbed by blood-filled structures. The at least one sensor may comprise a light detector. The light detector may be configured to detect photons reflected by tissue surrounding the blood-filled structures of the patient.

The at least one sensor may comprise a thermocouple configured to monitor the temperature of tissue in the vicinity of the distal end of the lead to facilitate a determination of the depth of the distal end of the lead in the patient. The at least one sensor may comprise a pH meter configured to monitor the pH level of tissue in the vicinity of the distal end of the lead to facilitate a determination of the depth of the distal end of the lead in the patient. The at least one sensor may comprise an electrical impedance sensor configured to monitor the level of electrical impedance of tissue in the vicinity of the distal end of the lead to facilitate a determination of the depth of the distal end of the lead in the patient.

In another aspect, a method of delivering a lead is disclosed. The method may comprise determining, using one or more sensors, the location of blood-filled structures in the vicinity of an intercostal space associated with a cardiac notch of the left lung of a patient. The method may comprise choosing a region for advancing a lead into intercostal muscles associated with the cardiac notch of the left lung of the patient, the region chosen based on the determined location of blood-filled structures, the lead configured to couple with a pulse generator for generating therapeutic electrical pulses for treating heart conditions in a patient. The method may comprise advancing the lead into the intercostal muscles associated with the cardiac notch of the left lung of the patient.

In some variations, one or more of the following features may optionally be included in any feasible combination. The method may comprise a light source configured to emit photons having a wavelength that is readily absorbed by blood-filled structures. The method may comprise a light detector configured to detect photons reflected by tissue surrounding the blood-filled structures of the patient. The light source and the light detector may be disposed at a distal tip of the lead.

The method may comprise ceasing advancing of the lead in response to a determination that a pH level measured by a pH sensor included at the distal tip of the lead matches a predetermined pH level of a desired location of the distal tip of the lead. The method may comprise ceasing advancing of the lead in response to a determination that a temperature measured by a temperature sensor included at the distal tip of the lead matches a predetermined temperature of a desired location of the distal tip of the lead.

In another aspect, a lead may be described. The lead may comprise a lead body having a distal end and a proximal end. The lead body may be configured to transmit electrical signals between the distal end and the proximal end. The proximal end may be configured to couple with a pulse generator for generating therapeutic electrical pulses for treating heart conditions in a patient. The lead may comprise an inflatable balloon disposed at the distal end of the lead body.

In some variations, one or more of the following features may optionally be included in any feasible combination. The inflatable balloon can be configured to be inflated to displace soft tissue elements of a patient during advancement of the distal end of the lead body through the patient. The inflatable balloon may be configured to be inflated to separate the distal end of the lead body from physiological elements of the patient.

The balloon may facilitate avoidance of perforation of physiological elements of the patient by the distal end of the lead body.

The inflatable balloon may be configured to inflate transversely from the lead body to displace the lead body from physiological elements of the patient. The inflatable balloon may be disposed on the sides of the lead body. The inflatable balloon may be disposed circumferentially around the lead body.

The details of one or more variations of the subject matter described herein are set forth in the accompanying drawings and the description below. Other features and advantages of the subject matter described herein will be apparent from the description and drawings, and from the claims. While certain features of the currently disclosed subject matter are described for illustrative purposes, it should be readily understood that such features are not intended to be limiting.

The claims that follow this disclosure are intended to define the scope of the protected subject matter.

DESCRIPTION OF DRAWINGS

The accompanying drawings, which are incorporated in and constitute a part of this specification, show certain aspects of the subject matter disclosed herein and, together with the description, help explain some of the principles associated with the disclosed implementations. In the drawings,

FIG. 1 is a front-view of an exemplary pulse generator having features consistent with implementations of the current subject matter;

FIG. 2 is a rear-view of an exemplary pulse generator having features consistent with implementations of the current subject matter;

FIG. 3 is an illustration of a simplified schematic diagram of an exemplary pulse generator having features consistent with implementations of the current subject matter;

FIG. 4A is an illustration showing exemplary placements of elements of a cardiac pacing system having features consistent with the current subject matter;

FIG. 4B is an illustration showing exemplary placements of elements of a cardiac pacing system having features consistent with the current subject matter;

FIG. 4C is a cross-sectional illustration of a thoracic region of a patient;

FIG. 5 is an illustration of an exemplary method of implanting a cardiac pacing system into a patient having features consistent with the current subject matter;

FIG. 6A is an illustration of an exemplary delivery system for a pulse generator having features consistent with implementations of the current subject matter;

FIG. 6B is an illustration of an exemplary delivery system with a pulse generator disposed therein consistent with implementations of the current subject matter;

FIG. 7 is an illustration of an exemplary process flow illustrating a method of placing a pacing lead having features consistent with the current subject matter;

FIG. 8A is an illustration of an exemplary lead having features consistent with the current subject matter;

FIG. 8B is an illustration of an exemplary lead having features consistent with the current subject matter;

FIG. 9A is an illustration of the distal end of an exemplary delivery system having features consistent with the current subject matter;

FIG. 9B is an illustration of an exemplary process for using the delivery system illustrated in FIG. 9A;

FIG. 10 is a schematic illustration of an exemplary delivery control system having features consistent with the current subject matter;

FIGS. 11A and 11B are illustrations of an exemplary lead having features consistent with the current subject matter;

FIG. 12 is an illustration of an exemplary sheath for delivering a lead, the sheath having features consistent with the current subject matter;

FIG. 13 is an illustration of an intercostal space associated with the cardiac notch of the left lung with an exemplary lead fixation receptacle having features consistent with the current subject matter inserted therein;

FIG. 14 is an illustration of an exemplary lead fixation receptacle having features consistent with the current subject matter;

FIG. 15 is an illustration of an exemplary lead fixation receptacle having features consistent with the current subject matter; and,

FIG. 16 is an illustration of an exemplary lead fixation receptacle having features consistent with the current subject matter.

When practical, similar reference numbers denote similar structures, features, or elements.

DETAILED DESCRIPTION

Implantable medical devices (IMDs), such as cardiac pacemakers or implantable cardioverter defibrillators (ICDs), provide therapeutic electrical stimulation to the heart of a patient. This electrical stimulation may be delivered via electrodes on one or more implantable endocardial or epicardial leads that are positioned in or on the heart. This electrical stimulation may also be delivered using a leadless cardiac pacemaker disposed within a chamber of the heart. Therapeutic electrical stimulation may be delivered to the heart in the form of electrical pulses or shocks for pacing, cardioversion or defibrillation.

An implantable cardiac pacemaker may be configured to facilitate the treatment of cardiac arrhythmias. The devices, systems and methods of the present disclosure may be used to treat cardiac arrhythmias including, but not limited to, bradycardia, tachycardia, atrial flutter and atrial fibrillation. Resynchronization pacing therapy may also be provided.

A cardiac pacemaker consistent with the present disclosure may include a pulse generator implanted adjacent the rib cage of the patient, for example, on the ribcage under the pectoral muscles, laterally on the ribcage, within the mediastinum, subcutaneously on the sternum of the ribcage, and the like. One or more leads may be connected to the pulse generator. A lead may be inserted, for example, between two ribs of a patient so that the distal end of the lead is positioned within the mediastinum of the patient adjacent, but not touching, the heart. The distal end of the lead may include an electrode for providing electrical pulse therapy to the patient's heart and may also include at least one sensor for detecting a state of the patient's organs and/or systems. The cardiac pacemaker may include a unitary design where the components of the pulse generator and lead are incorporated within a single form factor. For example, where a first portion of the unitary device resides within the subcutaneous tissue and a second portion of the unitary device is placed through an intercostal space into a location within the mediastinum.

FIG. 1 is a front-view 100 of a pulse generator 102 having features consistent with implementations of the current subject matter. The pulse generator 102 may be referred to as a cardiac pacemaker. The pulse generator 102 can include a housing 104, which may be hermetically sealed. In the present disclosure, and commonly in the art, housing 104 and everything within it may be referred to as a pulse generator, despite there being elements inside the housing other than those that generate pulses (for example, processors, storage, battery, etc.).

Housing 104 can be substantially rectangular in shape and the first end of the housing 104 may include a tapered portion 108. The tapered portion can include a first tapered edge 110, tapered inwardly toward the transverse plane. The tapered portion 108 can include a second tapered edge 112 tapered inwardly toward the longitudinal plane. Each of the first tapered edge 110 and the second tapered edge 112 may have a similar tapered edge generally symmetrically disposed on the opposite side of tapered portion 108, to form two pairs of tapered edges. The pairs of tapered edges may thereby form a chisel-shape at the first end 106 of pulse generator 102. When used in the present disclosure, the term

“chisel-shape” refers to any configuration of a portion of housing 104 that facilitates the separation of tissue planes during placement of pulse generator 102 into a patient. The “chisel-shape” can facilitate creation of a tightly fitting and properly sized pocket in the patient's tissue in which the pulse generator may be secured. For example, a chisel-shape portion of housing 104 may have a single tapered edge, a pair of tapered edges, 2 pairs of tapered edges, and the like. Generally, the tapering of the edges forms the shape of a chisel or the shape of the head of a flat head screwdriver. In some variations, the second end 114 of the pulse generator can be tapered. In other variations, one or more additional sides of the pulse generator 102 can be tapered.

Housing 104 of pulse generator 102 can include a second end 114. The second end 114 can include a port assembly 116. Port assembly 116 can be integrated with housing 104 to form a hermetically sealed structure. Port assembly 116 may be configured to facilitate the egress of conductors from housing 104 of pulse generator 102 while maintaining a seal. For example, port assembly 116 may be configured to facilitate the egress of a first conductor 118 and a second conductor 120 from housing 104. The first conductor 118 and the second conductor 120 may combine within port assembly 116 to form a twin-lead cable 122. In some variations, the twin-lead cable 122 can be a coaxial cable. The twin-lead cable 122 may include a connection port 124 remote from housing 104. Connection port 124 can be configured to receive at least one lead, for example, a pacing lead. Connection port 124 of the cable 122 can include a sealed housing 126. Sealed housing 126 can be configured to envelope a portion of the received lead(s) and form a sealed connection with the received lead(s).

Port assembly 116 may be made from a different material than housing 104. For example, housing 104 may be made from a metal alloy and port assembly 116 may be made from a more flexible polymer. While port assembly 116 may be manufactured separately from housing 104 and then integrated with it, port assembly 116 may also be designed to be part of housing 104 itself. The port assembly 116 may be externalized from the housing 104 as depicted in FIG. 1. The port assembly 116 may be incorporated within the shape of housing 104 of pulse generator 102.

FIG. 2 is a rear-view 200 of pulse generator 102 showing the back-side 128 of housing 104. As shown, pulse generator 102 can include one or more electrodes or sensors disposed within housing 104. As depicted in the example of FIG. 2, housing 104 includes a first in-housing electrode 130 and a second in-housing electrode 132. The various electrodes illustrated and discussed herein may be used for delivering therapy to the patient, sensing a condition of the patient, and/or a combination thereof. A pulse generator consistent with the present disclosure installed at or near the sternum of a patient can monitor the heart, lungs, major blood vessels, and the like through sensor(s) integrated into housing 104.

FIG. 3 is an illustration 300 of a simplified schematic diagram of an exemplary pulse generator 102 having features consistent with the current subject matter. Pulse generator 102 can include signal processing and therapy circuitry to detect various cardiac conditions. Cardiac conditions can include ventricular dyssynchrony, arrhythmias such as bradycardia and tachycardia conditions, and the like. Pulse generator 102 can be configured to sense and discriminate atrial and ventricular activity and then deliver appropriate electrical stimuli to the heart based on a sensed state of the heart.

Pulse generator **102** can include one or more components. The one or more components may be hermetically sealed within the housing **104** of pulse generator **102**. Pulse generator **102** can include a controller **302**, configured to control the operation of the pulse generator **102**. The pulse generator **102** can include an atrial pulse generator **304** and may also include a ventricular pulse generator **306**. Controller **302** can be configured to cause the atrial pulse generator **304** and the ventricular pulse generator **306** to generate electrical pulses in accordance with one or more protocols that may be loaded onto controller **302**. Controller **302** can be configured to control pulse generators **304**, **306**, to deliver electrical pulses with the amplitudes, pulse widths, frequency, or electrode polarities specified by the therapy protocols, to one or more atria or ventricles.

Controller electronic storage **308** can store instructions configured to be implemented by the controller to control the functions of pulse generator **102**.

Controller **302** can include a processor(s). The processor(s) can include any one or more of a microprocessor, a controller, a digital signal processor (DSP), an application specific integrated circuit (ASIC), a field-programmable gate array (FPGA), or equivalent discrete or analog logic circuitry. The functions attributed to controller **302** herein may be embodied as software, firmware, hardware or any combination thereof.

The pulse generator **102** can include a battery **310** to power the components of the pulse generator **102**. In some variations, battery **310** can be configured to charge a capacitor. Atrial pulse generator **304** and ventricular pulse generator **306** can include a capacitor charged by the battery **310**. The electrical energy stored in the capacitor(s) can be discharged as controlled by controller **302**. The electrical energy can be transmitted to its destination through one or more electrode leads **312**, **314**. The leads can include a ventricular pulsing lead **312**, an atrial pulsing lead **314**, and/or other leads.

Pulse generator **102** can include one or more sensors **322**. Sensor(s) **322** can be configured to monitor various aspects of a patient's physiology. Sensor(s) **322** may be embedded in the housing of pulse generator **102**, incorporated into leads **312**, **314** or be incorporated into separate leads. Sensors **322** of pulse generator **102** can be configured to detect, for example, signals from a patient's heart. The signals can be decoded by controller **302** of the pulse generator to determine a state of the patient. In response to detecting a cardiac arrhythmia, controller **302** can be configured to cause appropriate electrical stimulation to be transmitted through electrodes **312** and **314** by atrial pulse generator **304** and/or ventricular pulse generator **306**.

Sensor(s) **322** can be further configured to detect other physiological states of the patient, for example, a respiration rate, blood oximetry, and/or other physiological states. In variations where the pulse generator **102** utilizes a plurality of electrodes, controller **302** may be configured to alter the sensing and delivery vectors between available electrodes to enhance the sensitivity and specificity of arrhythmia detection and improve efficacy of the therapy delivered by the electrical impulses from the pulse generator **102**.

Pulse generator **102** can include a transceiver **316**. The transceiver can include an antenna **318**. The transceiver **316** can be configured to transmit and/or receive radio frequency signals. The transceiver **316** can be configured to transmit and/or receive wireless signals having any wireless communication protocol. Wireless communication protocols can include Bluetooth, Bluetooth low energy, Near-Field Communication, WiFi, and/or other radio frequency protocols.

The transceiver **316** can be configured to transmit and/or receive radio frequency signals to and/or from a programmer **320**. The programmer **320** can be a computing device external to the patient. Programmer **320** may comprise a transceiver configured to transmit and/or receive radio frequency signals to and/or from the transceiver **316** of the pulse generator **102**. Transceiver **316** can be configured to wirelessly communicate with programmer **320** through induction, radio-frequency communication or other short-range communication methodologies.

In some variations, programmer **320** can be configured to communicate with the pulse generator **102** through longer-range remote connectivity systems. Such longer-range remote connectivity systems can facilitate remote access, by an operator, to pulse generator **102** without the operator being in close proximity with the patient. Longer-range remote connectivity systems can include, for example, remote connectivity through the Internet, and the like. When an operator connects with pulse generator **102** through longer-range remote connectivity systems, a local device can be positioned within a threshold distance of the patient. The local device can communicate using one or more radio-frequency wireless connections with the pulse generator **102**. The local device can, in turn, include hardware and/or software features configured to facilitate communication between it and an operator device at which the operator is stationed. The local device can be, for example, a mobile computing device such as a smartphone, tablet, laptop, and the like. The local device can be a purpose-built local device configured to communicate with the pulse generator **102**. The local device can be paired with the pulse generator **102** such that the communications between the pulse generator **102** and the local device are encrypted. Communications between the local device and the operator device can be encrypted.

Programmer **320** can be configured to program one or more parameters of the pulse generator **102**. The parameter(s) can include timing of the stimulation pulses of the atrial pulse generator, timing of the stimulation pulses of the ventricular pulse generator, timing of pulses relative to certain sensed activity of the anatomy of the patient, the energy levels of the stimulation pulses, the duration of the stimulation pulses, the pattern of the stimulation pulses and other parameters. The programmer **320** can facilitate the performance of diagnostics on the patient or the pulse generator **102**.

Programmer **320** can be configured to facilitate an operator of the programmer **320** to define how the pulse generator **102** senses electrical signals, for example ECGs, and the like. The programmer **320** can facilitate an operator of the programmer **320** to define how the pulse generator **102** detects cardiac conditions, for example ventricular dyssynchrony, arrhythmias, and the like. The programmer **320** can facilitate defining how the pulse generator **102** delivers therapy, and communicates with other devices.

An operator can fine-tune parameters through the programmer **320**. For example, the sensitivity of sensors embodied in the housing of the pulse generator **302**, or within leads, can be modified. Programmer **320** can facilitate setting up communication protocols between the pulse generator **102** and another device such as a mobile computing device. Programmer **320** can be configured to facilitate modification of the communication protocols of the pulse generator **102**, such as adding security layers, or preventing two-way communication. Programmer **320** can be config-

ured to facilitate determination of which combination of implanted electrodes are best suited for sensing and therapy delivery.

Programmer 320 can be used during the implant procedure. For example, programmer 320 can be used to determine if an implanted lead is positioned such that acceptable performance will be possible. If the performance of the system is deemed unacceptable by programmer 320, the lead may be repositioned by the physician, or an automated delivery system, until the lead resides in a suitable position. Programmer 320 can also be used to communicate feedback from sensors disposed on the leads and housing 104 during the implant procedure.

In some cases, concomitant devices such as another pacemaker, an ICD, or a cutaneous or implantable cardiac monitor, can be present in a patient, along with pulse generator 102. Pulse generator 102 can be configured to communicate with such concomitant devices through transceiver 316 wirelessly, or the concomitant device may be physically connected to pulse generator 102. Physical connection between devices may be accomplished using a lead emanating from pulse generator 102 that is compatible with the concomitant device. For example, the distal end of a lead emanating from pulse generator 102 may be physically and electrically connected to a port contained on the concomitant device. Physical connection between devices may also be accomplished using an implantable adaptor that facilitates electrical connection between the lead emanating from pulse generator 102 and the concomitant device. For example, an adapter may be used that will physically and electrically couple the devices despite not having native components to facilitate such connection. Concomitant devices may be connected using a “smart adapter” that provides electrical connection between concomitant devices and contains signal processing capabilities to convert signal attributes from each respective device such that the concomitant devices are functionally compatible with each other.

Pulse generator 102 can be configured to have a two-way conversation or a one-way conversation with a concomitant device. Controller 302 can be configured to cause the concomitant device to act in concert with pulse generator 102 when providing therapy to the patient, or controller 302 can gather information about the patient from the concomitant device.

In some variations, pulse generator 102 can be configured to be triggered via one-way communication from a concomitant device to pulse generator 102.

FIGS. 4A and 4B are illustrations showing exemplary placements of elements of a cardiac pacing system having features consistent with the present disclosure. Pulse generator 102 can be disposed in a patient, adjacent an outer surface of ribcage 404. For example, pulse generator 102 can be disposed on the sternum 402 of the patient’s ribcage 404. A lead 414, attached to pulse generator 102, may also be disposed in the patient by traversing through intercostal muscle 410 of the patient. Lead 414 may optionally pass through a receptacle 408 in intercostal muscle 410 to guide the lead, fix the lead, and/or electrically insulate the lead from the tissue of the intercostal muscle 410 (examples of such receptacles are described herein with respect to FIGS. 13-16).

In other variations, pulse generator 102 can be disposed outside of a patient’s ribcage in a pectoral position, outside of the patient’s ribcage in a lateral position, below (inferior to) the patient’s ribcage in a subxiphoid or abdominal position, within the patient’s mediastinum, or the like.

Lead 414 may be passed through the ribcage so the distal end of the lead and its electrodes are disposed on, or pass through, the inner surface of the rib or inner surface of the innermost intercostal muscle, or may alternatively traverse further within the thoracic cavity, but without physically contacting the tissue comprising the heart. This placement may be referred to herein as intracostal or intracostally.

Leads may be inserted between any two ribs within the thoracic cavity, for example, as shown in FIG. 4A. In some variations, it is desirable to insert the lead through one of the intercostal spaces associated with cardiac notch of the left lung 420. For example, between the fourth and fifth ribs or between the fifth and sixth ribs. Due to variations in anatomy, the rib spacing associated with the cardiac notch of the left lung 420 may differ. In some patients the cardiac notch of the left lung 420 may not be present or other cardiac anomalies such as dextrocardia may require the insertion through alternative rib spaces. Lead 414 may be inserted into such a location through an incision 406, as shown in FIG. 4A. Lead 414 may optionally be inserted into such a location through a receptacle 408, as shown in FIG. 4B.

Precise placement of a distal end of lead 414, which may include electrode(s) for pacing or sensing, is now described further with reference to the anatomical illustrations of FIGS. 4A, 4B and 4C. In some variations, the distal end of lead 414 can be located within the intercostal space or intercostal muscle 410. In such variations, the distal end of lead 414 is preferably surrounded by a receptacle 408 that electrically insulates the distal end of the lead 414 from the intercostal muscle 410. In another variation, the distal end of lead 414 may be placed just on the inner surface of a rib or on the inner surface of the innermost intercostal muscle.

The distal end of lead 414 can also be positioned so as to abut the parietal pleura of the lung 426. In other variations, the distal end of lead 414 can be positioned so as to terminate within the mediastinum 428 of the thoracic cavity of the patient, proximate the heart 418, but not physically in contact with the heart 418 or the pericardium 432 of heart 418. Alternatively, the distal end of lead 414 can be placed to abut the pericardium 432, but not physically attach to the epicardial tissue comprising the heart.

The distal end of lead 414 may be physically affixed to cartilage or bone found within the thoracic cavity, for example, to a rib, to cartilage of a rib, or to other bone or cartilage structure in the thoracic cavity. In one variation, the lead can be disposed such that it is wrapped around the patient’s sternum 402.

For certain placements, lead 414 can be adequately fixed by direct physical contact with surrounding tissue. In other variations, an additional fixation mechanism may be used. For example, the distal end of lead 414 can incorporate a fixation mechanism such as a tine, hook, spring, screw, or other fixation device. The fixation mechanism can be configured to secure the lead in the surrounding tissue, cartilage, bone, or other tissue, to prevent the lead from migrating from its original implantation location.

FIG. 5 is an illustration 500 of an exemplary method of implanting a cardiac pacing system into a patient consistent with the present disclosure. At 502, a pulse generator 102 may be implanted, in a manner described above, adjacent the sternum 402 of a patient. Optionally, pulse generator 102 may be at least partially chisel-shaped to facilitate implantation and the separation of tissue planes. At 504, a lead 414 may be inserted into an intercostal space 410 of a patient. As described above, lead 414 may optionally be inserted into a receptacle 408 disposed within intercostal space 410. At

506, the distal end of lead 414 is delivered to one of a number of suitable final locations for pacing, as described above.

FIG. 6A is an illustration 600 of a pulse generator delivery system 602 for facilitating positioning of pulse generator 102 into a patient, the delivery system 602 having features consistent with the current subject matter. FIG. 6B is an illustration 604 of the delivery system 602 as illustrated in FIG. 6A with the pulse generator 102 mounted in it. Delivery system 602 can be configured to facilitate implantation of the pulse generator 102 into the thoracic region of a patient.

Delivery system 602 includes a proximal end 606 and a distal end 608. The distal end 608 of delivery system 602 contains a receptacle 610 in which the housing of the pulse generator 102 is loaded. Where the pulse generator 102 contains a connection lead, the delivery system 602 can be configured to accommodate the connection lead so that the connection lead will not be damaged during the implantation of the pulse generator 102.

When pulse generator 102 is fully loaded into delivery system 602, pulse generator 102 is substantially embedded into the receptacle 610. In some variations, a portion of the pulse generator 102's distal end can be exposed, protruding from the end of receptacle 610. The tapered shape of the distal end 106 of pulse generator 102 can be used in conjunction with the delivery system 602 to assist with separating tissue planes as delivery system 602 is used to advance pulse generator 102 to its desired location within the patient.

In some variations, the entirety of pulse generator 102 can be contained within receptacle 610 of the delivery system 602. The pulse generator 102 in such a configuration will not be exposed during the initial advancement of delivery system 602 into the patient. The distal end 608 of delivery system 602 may be designed to itself separate tissue planes within the patient as delivery system 602 is advanced to the desired location within the patient.

The pulse generator delivery system 602 may be made from a polymer, a metal, a composite material or other suitable material. Pulse generator delivery system 602 can include multiple components. Each component of the pulse generator delivery system 602 can be formed from a material suitable to the function of the component. The pulse generator delivery system 602 can be made from a material capable of being sterilized for repeated use with different patients.

Pulse generator delivery system 602 may include a handle 612. Handle 612 can facilitate advancement of delivery system 602 and pulse generator 102 into a patient's body. Handle 612 can be disposed on either side of the main body 614 of the delivery system 602, as illustrated in FIGS. 6A and 6B. In some variations, handle 612 can be disposed on just one side of the main body 614 of the delivery system 602. The handle 612 can be configured to be disposed parallel to plane of insertion and advancement 616 of pulse generator delivery system 602 within the body. In some variations, handle 612 can be located orthogonally to the plane of insertion and advancement 616 of the delivery system 602. Handle 612 can be configured to facilitate the exertion of pressure, by a physician, onto the pulse generator delivery system 602, to facilitate the advancement and positioning of the delivery system 602 at the desired location within the patient.

Pulse generator delivery system 602 can include a pulse generator release device 618. The release device 618 can be configured to facilitate disengagement of the pulse generator 102 from the delivery system 602. In some variations,

release device 618 can include a plunger 620. Plunger 620 can include a distal end configured to engage with the proximal end 606 of the pulse generator delivery system 602. The plunger 620 can engage with the proximal end 606 of the pulse generator delivery system 602 when the pulse generator 102 is loaded into the receptacle 610 of the delivery system 602. The proximal end 622 of the plunger 620 can extend from the proximal end 606 of the delivery system 602.

Plunger 620 can include a force applicator 624. Force applicator 624 can be positioned at the proximal end 622 of plunger 620. Force applicator 624 can be configured to facilitate application of a force to the plunger 620 to advance the plunger 620. Advancing plunger 620 can force pulse generator 102 from the delivery system 602. In some variations, the force applicator 624 can be a ring member. The ring member can facilitate insertion, by the physician, of a finger. Pressure can be applied to the plunger 620 through the ring member, forcing the pulse generator 102 out of the receptacle 610 of the delivery system 602 into the patient at its desired location. In some variations, the proximal end 622 of the plunger 620 can include a flat area, for example, similar to the flat area of a syringe, that allows the physician to apply pressure to the plunger 620. In some variations, the plunger 620 can be activated by a mechanical means such as a ratcheting mechanism.

The distal end 608 of the pulse generator delivery device 602 can include one or more sensors. The sensor(s) can be configured to facilitate detection of a state of patient tissues adjacent distal end 608 of the pulse generator delivery device 602. Various patient tissues can emit, conduct and/or reflect signals. The emitted, conducted and/or reflected signals can provide an indication of the type of tissue encountered by the distal end 608 of the pulse generator delivery device 602. Such sensor(s) can be configured, for example, to detect the electrical impedance of the tissue adjacent the distal end 608 of the pulse generator delivery device 602. Different tissues can have different levels of electrical impedance. Monitoring the electrical impedance can facilitate a determination of the location, or tissue plane, of the distal end 608 of the delivery device 602.

In addition to delivery of the pulse generator, delivery of at least one lead for sensing and/or transmitting therapeutic electrical pulses from the pulse generator is typically required. Proper positioning of the distal end of such lead(s) relative to the heart is very important. Delivery systems are provided that can facilitate the insertion of one or more leads to the correct location(s) in the patient. The delivery systems can facilitate finding the location of the initial insertion point for the lead. The initial insertion point optionally being an intercostal space associated with a patient's cardiac notch of the left lung. The intercostal spaces associated with the cardiac notch commonly include the left-hand-side fourth, fifth and sixth intercostal spaces. Other intercostal spaces on either side of the sternum may be used, especially when the patient is experiencing conditions that prevent use of the fourth, fifth and sixth intercostal spaces, or due to anatomical variations.

When making the initial insertion through the epidermis and the intercostal muscles of the patient, it is important to avoid damaging important blood-filled structures of the patient. Various techniques can be employed to avoid damaging important blood-filled structures. For example, sensors can be used to determine the location of the blood-filled structures. Such sensors may include accelerometers configured to monitor pressure waves caused by blood flowing through the blood-filled structures. Sensors configured to

emit and detect light-waves may be used to facilitate locating tissues that absorb certain wavelengths of light and thereby locate different types of tissue. Temperature sensors may be configured to detect differences in temperature between blood-filled structures and surrounding tissue. Lasers and detectors may be employed to scan laser light across the surface of a patient to determine the location of subcutaneous blood-filled structures.

Conventional medical devices may be employed to locate the desired initial insertion point into the patient. For example, x-ray machines, MRI machines, CT scanning machines, fluoroscopes, ultrasound machines and the like, may be used to facilitate determination of the initial insertion point for the leads as well as facilitate in advancing the lead into the patient.

Advancing a lead into a patient can also present the risk of damaging physiological structures of the patient. Sensors may be employed to monitor the characteristics of tissues within the vicinity of the distal end of an advancing lead. Readings from sensors associated with the characteristics of tissues can be compared against known characteristics to determine the type of tissue in the vicinity of the distal end of the advancing lead.

Sensors, such as pH sensors, thermocouples, accelerometers, electrical impedance monitors, and the like, may be used to detect the depth of the distal end of the electrode in the patient. Physiological characteristics of the body change the further a lead ventures into it. Measurements performed by sensors at, or near, the distal end of the advancing lead may facilitate the determination of the type of tissue in the vicinity of the distal end of the lead, as well as its depth into the patient.

Various medical imaging procedures, may be used on a patient to determine the location of the desired positions in the heart for the distal end of the lead(s). This information can be used, in conjunction with sensor readings, of the kind described herein, to determine when the distal end of the lead has advanced to a desired location within the patient.

Components may be used to first create a channel to the desired location for the distal end of the lead. Components can include sheaths, needles, cannulas, balloon catheters and the like. A component may be advanced into the patient with the assistance of sensor measurements to determine the location of the distal end of the component. Once the component has reached the desired location, the component may be replaced with the lead or the lead may be inserted within the component. An example of a component can include an expandable sheath. Once the sheath has been advanced to the desired location, a cannula extending the length of the sheath may be expanded, allowing a lead to be pass through the cannula. The sheath may then be removed from around the lead, leaving the lead in situ with the distal end of the lead at the desired location.

Determination of the final placement of the distal end of a lead is important for the delivery of effective therapeutic electrical pulses for pacing the heart. The present disclosure describes multiple technologies to assist in placement of a lead in the desired location. For example, the use of sensors on the pulse generator, on the distal end of leads, or on delivery components. In addition, when a lead or component is advanced into a patient, balloons may be employed to avoid damaging physiological structures of the patient. Inflatable balloons may be disposed on the distal end of the lead or component, on the sides of a lead body of the lead, or may be circumferentially disposed about the lead body. The balloons may be inflated to facilitate the displacement of tissue from the lead to avoid causing damage to the tissue

by the advancing lead. A lead delivery assembly may also be used to facilitate delivery of the lead to the desired location. In some variations, the lead delivery assembly may be configured to automatically deliver the distal end of the lead to the desired location in the patient. Such a lead delivery system is disclosed in co-owned U.S. patent application Ser. No. 14/846,578, filed Sep. 4, 2015, the disclosure of which is incorporated herein by reference.

FIG. 7 is an illustration 700 of an exemplary process flow illustrating a method of delivering a lead having features consistent with the present disclosure. At 702, the location of blood-filled structures, in the vicinity of an intercostal space, can be determined. The intercostal space can be an intercostal space associated with the cardiac notch of the patient. Determining the location of the blood-filled structures may be facilitated by one or more sensors configured to detect the location of blood-filled structures.

At 704, a region can be chosen for advancing of a lead through intercostal muscles associated with the cardiac notch. The region chosen may be based on the determined location of blood-filled structures of the patient in that region. It is important that damage to blood-filled structures, such as arteries, veins, and the like, is avoided when advancing a lead into a patient.

At 706, a lead can be advanced through the intercostal muscles associated with the cardiac notch of the patient. Care should be taken to avoid damaging important physiological structures. Sensors, of the kind described herein, may be used to help avoid damage to important physiological structures.

At 708, advancement of the lead through the intercostal muscles can be ceased. Advancement may be ceased in response to an indication that the distal end of the lead has advanced to the desired location. Indication that the distal end of the lead is at the desired location may be provided through measurements obtained by one or more sensors of the kind described herein.

The lead advanced through the intercostal muscles associated with the cardiac notch of the patient can be configured to transmit therapeutic electrical pulses to pace the patient's heart. FIG. 8A is an illustration 800a of an exemplary lead 802 having features consistent with the present disclosure. For the lead to deliver therapeutic electrical pulses to the heart for pacing the heart, a proximal end 804 of lead 802 is configured to couple with the pulse generator 102. The proximal end 804 of lead 802 may be configured to couple with a connection port 124. The connection port can be configured to couple the proximal end 804 of lead 802 to one or more conductors, such as conductors 118 and 120. When the proximal end 804 of lead 802 couples with connection port 124, a sealed housing may be formed between them. In some variations, the materials of connection port 124 and the proximal end 804 of lead 802 may be fused together. In some variations, the proximal end 804 of lead 802 may be configured to be pushed into the sealed housing 126, or vice versa. Optionally, the external diameter of the inserted member may be slightly greater than the internal diameter of the receiving member causing a snug, sealed fit between the two members. Optionally, a mechanism, such as a set-screw or mechanical lock, may be implemented upon the connection port 124 or proximal lead end 804 in order to prevent unintentional disconnection of the lead 802 from pulse generator 102.

Also shown in FIG. 8A is the distal end 806 of lead 802. The distal end 806 of lead 802 may comprise an electrode 808. In some variations, lead 802 may include a plurality of electrodes. In such variations, lead 802 may include a

multiple-pole lead. Individual poles of the multiple-pole lead can feed into separate electrodes. Electrode **808** at the distal end **806** of lead **802** may be configured to deliver electrical pulses to pace the heart when located in the desired position for pacing the heart.

The distal end **806** of lead **802** can include one or more sensors **810**. Sensor(s) **810** can be configured to monitor physiological characteristics of the patient while the distal end **806** of lead **802** is being advanced into the patient. Sensors can be disposed along the length of lead **802**. For example, sensor **812** is disposed some distance from the distal end **806**. Such sensors incorporated onto the lead can detect subtle physiological, chemical and electrical differences that distinguish the lead's placement within the desired location, as opposed to other locations in the patient's thoracic cavity.

In some variations, the proximal end **804** of lead **802** may be coupled with pulse generator **102** prior to the distal end **806** of lead **802** being advanced through the intercostal space of the patient. In some variations, the proximal end **804** of the lead **802** may be coupled with pulse generator **102** after the distal end **806** of lead **802** has been advanced to the desired location.

To assist in the placement of the lead, various medical instruments may be used. The medical instruments may be used alone, or in combination with sensors disposed on the lead that is being placed. Medical instruments may be used to help the physician to access the desired location for the placement of a lead and/or confirm that the distal end of the lead has reached the desired location. For example, instruments, such as an endoscope or laparoscopic camera, with its long, thin, flexible (or rigid) tube, light and video camera can assist the physician in confirming that the distal end **806** of lead **802** has reached the desired location within the thoracic cavity. Other tools known to one skilled in the art such as a guidewire, guide catheter, or sheath may be used in conjunction with medical instruments, such as the laparoscopic camera, and may be advanced alongside and to the location identified by the medical instruments. Medical instruments such as a guidewire can be advanced directly to the desired location for the distal end of the lead with the assistance of acoustic sound, ultrasound, real-time spectroscopic analysis of tissue, real-time density analysis of tissue or by delivery of contrast media that may be observed by real-time imaging equipment.

In some variations, the patient may have medical devices previously implanted that may include sensors configured to monitor physiological characteristics of the patient. The physiological characteristics of the patient may change based on the advancement of the lead through the intercostal space of the patient. The previously implanted medical device may have sensors configured to detect movement of the advancing lead. The previously implanted medical device can be configured to communicate this information back to the physician to verify the location of the advancing lead.

Sensors disposed on the lead, such as sensors **810** disposed on distal end **806** of the lead may be used to facilitate the delivery of the lead to the desired location. Sensor(s) **810** can be configured to facilitate determination of a depth of the distal end **806** of lead **802**. As described above, the depth of the desired location within the patient can be determined using one or more medical instruments. This can be determined during implantation of the lead **802** or prior to the procedure taking place.

Although sensor(s) **810** is illustrated as a single element in FIG. **8A**, sensor(s) **810** can include multiple separate

sensors. The sensors **810** can be configured to facilitate placement of the distal end **806** of the lead **802** at a desired location and verification thereof.

Sensor(s) **810** can be configured to transmit sensor information during advancement to the desired location. Sensor(s) **810** may transmit signals associated with the monitored physiological characteristics of the tissue within the vicinity of the distal end **806** of the lead **802**. In some variations, the signals from sensor(s) **810** may be transmitted to a computing device(s) configured to facilitate placement of the lead **802** in the desired location. In such variations, the computing device(s) can be configured to assess the sensor information individually, or in the aggregate, to determine the location of the distal end **806** of lead **802**. The computing device(s) can be configured to present alerts and/or instructions associated with the position of the distal end **806** of lead **802**.

In some variations, lead **802** can be first coupled with connection port **124** of pulse generator **102**. Signals generated by sensor(s) **810** can be transmitted to a computing device(s) using transceiver **316** in pulse generator **102**, as illustrated in FIG. **3**.

An accelerometer may be used to facilitate delivery of the distal end **806** of lead **802** to the desired location. An accelerometer may be disposed at the distal end **806** of lead **802**. The accelerometer may be configured to monitor the movement of the distal end **806** of lead **802**. The accelerometer may transmit this information to a computing device or the physician. The computing device, or the physician, can determine the location of the distal end **806** of the lead **802** based on the continuous movement information received from the accelerometer as the lead **802** is advanced into the patient. The computing device or the physician may know the initial entry position for lead **802**. The movement information can indicate a continuous path taken by the lead **802** as it advanced into the body of the patient, thereby providing an indication of the location of the distal end **806** of lead **802**. Pressure waves from the beating heart may differ as absorption changes within deepening tissue planes. These pressure wave differences may be used to assess the depth of the distal end of the electrode.

The accelerometer can also be configured to monitor acoustic pressure waves generated by various anatomical structures of the body. For example, the accelerometer can be configured to detect acoustic pressure waves generated by the heart or by other anatomical structures of the body. The closer the accelerometer gets to the heart, the greater the acoustic pressure waves generated by the heart will become. By comparing the detected acoustical pressure waves with known models, a location of the distal end **806** of lead **802** can be determined.

Pressure waves or vibrations can be artificially generated to cause the pressure waves or vibrations to traverse through the patient. The pressure waves or vibrations can be generated in a controlled manner. The pressure waves or vibrations may be distorted as they traverse through the patient. The level of type of distortion that is likely to be experienced by the pressure waves or vibrations may be known. The pressure waves or vibrations detected by the accelerometer can be compared to the known models to facilitate determination or verification of the location of the distal end **806** of lead **802**.

Different tissues within a body exhibit different physiological characteristics. The same tissues situated at different locations within the body can also exhibit different physiological characteristics. Sensors, disposed on the distal end **806**, of lead **802** can be used to monitor the change in

the physiological characteristics as the distal end **806** is advanced into the body of the patient. For example, the tissues of a patient through which a lead is advanced can demonstrate differing resistances, physiological properties, electrical impedance, temperature, pH levels, pressures, and the like. These different physiological characteristics, and the change in physiological characteristics, experienced as a sensor traverses through a body can be known or identified. For example, even if the actual degree is not known ahead of time, the change in sensor input when the sensor traverses from one tissue media to another may be identifiable in real-time. Consequently, sensors configured to detect physiological characteristics of a patient can be employed to facilitate determining and verifying the location of the distal end **806** of lead **802**.

Different tissues can exhibit different insulative properties. The insulative properties of tissues, or the change in insulative properties of tissues, between the desired entry-point for the lead and the desired destination for the lead can be known. Sensor **810** can include an electrical impedance detector. An electrical impedance detector can be configured to monitor the electrical impedance of the tissue in the vicinity of the distal end **806** of lead **802**. The electrical impedance of the tissue monitored by the electrical impedance detector can be compared with the known insulative properties of the tissues between the entry point and the destination, to determine the location of the distal end of lead **802** or a transition from one tissue plane to another may be recognized by a measurable change in the measured impedance.

Varying levels of electrical activity can be experienced at different locations with the body. Electrical signals emitted from the heart, or other muscles can send electrical energy through the body. This electrical energy will dissipate the further it gets from its source. Various tissues will distort the electrical energy in different ways. Sensors configured to detect the electrical energy generated by the heart and/or other anatomical structures can monitor the electrical energy as the lead is advanced. By comparing the monitored electrical energy with known models, a determination or verification of the location of the distal end **806** of lead **802** can be made. The sensors may be configured to identify sudden changes in the electrical activity caused by advancement of the sensor into different tissue planes.

Tissues throughout the body have varying pH levels. The pH levels of tissues can change with depth into the body. Sensor(s) **810** can include a pH meter configured to detect the pH levels of the tissue in the vicinity of the sensor(s) **810** as the sensor(s) advance through the patient. The detected pH levels, or detected changes in pH levels, can be compared with known models to facilitate determination or verification of the location of the distal end **806** of lead **802**. The pH meter may be configured to identify sudden changes in the pH level caused by advancement of the meter into different tissue planes.

Different tissues can affect vibration-waves or sound-waves in different ways. Sensor(s) **810** can include acoustic sensors. The acoustic sensors can be configured to detect vibration waves or sound waves travelling through tissues surrounding sensor(s) **810**. The vibration waves can be emitted by vibration-emitting devices embedded in the lead **802**. The vibration waves can be emitted by vibration-emitting devices located on a hospital gurney, positioned on the patient, or otherwise remote from lead **802**. Sensor(s) **810** can be configured to transmit detected vibration-wave information to a computing device configured to determine

the location of the distal end **806** of lead **802** based on the detected vibration-wave information.

Different tissues can have different known effects on the emitted electromagnetic waves. Sensors can be used to detect the effect that the tissue in the vicinity of the sensors have on the electromagnetic waves. By comparing the effect that the tissue has on the electromagnetic waves with known electromagnetic effects, the identity of the tissue can be obtained and the location of the lead can be determined or verified. For example, sensor(s) **810** can include electromagnetic wave sensors. Electromagnetic wave sensors can include an electromagnetic wave emitter and an electromagnetic wave detector. The electromagnetic waves will be absorbed, reflected, deflected, and/or otherwise affected by tissue surrounding sensor(s) **810**. Sensor(s) **810** can be configured to detect the change in the reflected electromagnetic waves compared to the emitted electromagnetic waves. By comparing the effect the tissue in the vicinity of the sensor(s) **810** has on the electromagnetic waves with known models, a determination verification of the location of lead **802** can be made. The sensors may be configured to identify sudden changes in the electromagnetic activity caused by advancement of the sensor into different tissue planes.

FIG. 9A is an illustration **900** of the distal end of an exemplary delivery system **902** having features consistent with the presently described subject matter. While FIG. 9A is described with reference to a delivery system, one of ordinary skill in the art can appreciate and understand that the technology described herein could be applied directly to the end of a lead, such as lead **802**. The present disclosure is intended to apply to a delivery system, such as delivery system **902**, as well as a lead, such as lead **802**.

Delivery system **902** can facilitate placement of the distal end of a lead, such as lead **802** illustrated in FIG. 8, to a desired location by use of electromagnetic waves, such as light waves. Delivery system **902** may comprise a delivery catheter body **904**. Delivery catheter body **904** may be configured to facilitate advancement of delivery catheter body **904** into the patient to a desired location. The distal tip **906** of delivery catheter body **904** may comprise a light source **908**. Light source **908** can be configured to emit photons having a visible wavelength, infrared wavelength, ultraviolet wavelength, and the like. Delivery catheter body **904** may comprise a light detector **910**. Light detector **910** may be configured to detect light waves, emitted by the light source **908**, reflected by tissues surrounding distal tip **906** of delivery catheter body **904**.

FIG. 9B is an illustration **912** of an exemplary process for using the delivery system illustrated in FIG. 9A. Light detector **910** can be configured to detect light waves reflected by the tissue adjacent the distal end **906** of delivery system **902**. Information associated with the detected light waves may be transmitted to a computing device. The computing device can be configured to interpret the information transmitted from light detector **910** and determine a difference between the light emitted and the light detected.

At **914**, light source **908** can be activated. Light source **908** may emit light-waves into the tissue in the general direction of the intended advancement of delivery system **902**. At **916**, the tissue can absorb a portion of the emitted light waves. At **918**, light detector **910** can detect the reflected light waves, reflected by tissues surrounding light source **908**. At **920**, a determination of a change in the absorption of the light waves by tissues surrounding the distal tip **906** of delivery system **902** can be made.

At **922**, in response to an indication that the absorption of light waves has not changed, delivery system **902** can be

configured to advance a delivery system, such as delivery system **902**, into the patient. In some variations, a physician can advance delivery system **902** into the patient. In other variations, the delivery system **902** can be advanced into the patient automatically.

At **924**, in response to an indication that the absorption of light waves has changed, an alert can be provided to the physician. In some variations, the alert can be provided to the physician through a computing device configured to facilitate positioning of delivery system **902** into the patient.

In some variations, a computing device may be configured to facilitate positioning of delivery system **902** into the patient. The computing device can be configured to alert the physician to the type of tissue in the vicinity of distal tip **906** of delivery system **902**. In some variations, the computing device can be configured to alert the physician when the distal tip **906** reaches a tissue having characteristics consistent with the desired location of the distal tip **906** of delivery system **902**. For example, when the characteristics of the tissue in the vicinity of the distal tip **906** match those within the intercostal tissues, or a particular location within the mediastinum, an alert may be provided.

Blood vessels, both venous and arterial, absorb red, near infrared and infrared (IR) light waves to a greater degree than surrounding tissues. When illuminating the surface of the body with red, near infrared and infrared (IR) light waves, blood rich tissues, for example veins, will absorb more of this light than other tissues, and other tissues will reflect more of this light than the blood rich tissues. Analysis of the pattern of reflections can enable the blood rich tissues to be located. A positive or negative image can be projected on the skin of the patient at the location of the vein. In some variations, the vein can be represented by a bright area and the absence of a vein can be represented as a dark area, or vice versa.

Delivery system **902** can include a subcutaneous visualization enhancer. The subcutaneous visualization enhancer may be configured to enhance visualization of veins, arteries, and other subcutaneous structures of the body. The subcutaneous visualization enhancer can include moving laser light sources to detect the presence of blood-filled structures, such as venous or arterial structures below the surface of the skin. The subcutaneous visualization enhancer can include systems configured to project an image onto the surface of the skin that can show an operator the pattern of the detected subcutaneous blood-filled structures. Laser light from laser light sources can be scanned over the surface of the body using mirrors. A light detector can be configured to measure the reflections of the laser light and use the pattern of reflections to identify the targeted blood rich structures.

Such subcutaneous visualization enhancers can be used to facilitate determination of the location for the initial approach for inserting a lead, such as lead **802**, through the intercostal space associated with the cardiac notch of the patient. In some variations, the visualization enhancers can be disposed remote from the delivery system and/or can be configured to enhance visualization enhancers disposed on the delivery system.

With the provision of a visualization of the detected subcutaneous structures, the physician can assess the position of subcutaneous structures such as the internal thoracic artery, or other structures, of the body while concurrently inserting components of the delivery system into the body, while avoiding those subcutaneous structures.

In some variations, during advancement of lead **802** through the intercostal space associated with the cardiac notch, sensor(s) **810** can be configured to transmit obtained

readings to a computing device for interpretation. In some variations, the computing device is pulse generator **102**. In some variations, pulse generator **102** is used to transmit the readings to an external computing device for interpretation. In any event, the sensor information from the various sensors can be used individually, or accumulatively, to determine the location of the distal end of lead **802**.

FIG. **10** is a schematic illustration of a delivery control system **1000** having features consistent with the current subject matter. The delivery control system **1000** can be configured to automatically deliver a lead to the desired position within the patient. For example, the delivery control system **1000** can be configured to automatically deliver a distal tip of a lead through the intercostal space associated with the cardiac notch.

Delivery control system **1000** can be configured to receive a plurality of inputs. The inputs can come from one or more sensors disposed in, or on, the patient. For example, delivery control system **1000** can be configured to receive subcutaneous structure visualization information **1002**, information associated with delivery insertion systems **1004**, information associated with sensors **1006**, and the like.

Delivery control system **1000** can be configured to use remote sensors **1006** to facilitate determination of the insertion site for the lead. Sensors **1006** can be disposed in various instruments configured to be inserted into the patient. Sensors **1006** can also be disposed in various instruments configured to remain external to the patient.

Delivery control system **1000** can be configured to perform depth assessments **1008**. The depth assessments **1008** can be configured to determine the depth of the distal end of an inserted instrument, such as a lead **802** illustrated in FIG. **8A**. Depth assessments **1008** can be configured to determine the depth of the distal end of the inserted instrument through light detection systems **1010**, pressure wave analysis **1012**, acoustic analysis, and the like.

Depth assessments **1008** can be configured to determine the depth of the delivery system, or lead, though pressure wave analysis systems **1012**. Pressure waves can be detected by accelerometers as herein described.

Depth assessments **1008** can be configured to determine the depth of the delivery system though acoustic analysis systems **1014**. Acoustic analysis system **1014** can be configured to operate in a similar manner to a stethoscope. The acoustic analysis system **1014** can be configured to detect the first heart sound (S1), the second heart sound (S2), or other heart sounds. Based on the measurements obtained by the acoustic analysis system **1014**, a depth and/or location of the distal end of a delivery system and/or inserted medical component can be determined. The acoustic analysis system **1014** can be configured to measure the duration, pitch, shape, and tonal quality of the heart sounds. By comparing the duration, pitch, shape, and tonal quality of the heart sounds with known models, a determination or verification of the location of the lead can be made. Sudden changes in the degree of heart sounds may be used to indicate advancement into a new tissue plane.

In some variations, the lead can include markers or sensors that facilitate the correct placement of the lead. Certain markers such as a visual scale, radiopaque, magnetic, ultrasound markers, and the like, can be positioned at defined areas along the length of the lead so that the markers can be readily observed by an implanting physician, or automated system, on complementary imaging instruments such as fluoroscopy, x-ray, ultrasound, or other imaging instruments known in the art. Through the use of these markers, the physician, or automated implantation device,

can guide the lead to the desired location within the intercostal muscle, pleural space, mediastinum, or other desired position, as applicable.

Avoiding damage to tissues in the vicinity of the path-of-travel for the lead is important. Moving various tissues from the path of the lead without damaging them is also important. FIGS. 11A and 11B are illustrations 1100 and 1102 of an exemplary lead 802 having features consistent with the present disclosure for moving and avoiding damage to tissues during lead delivery. Lead 802 can comprise a distal tip 1104. Distal tip 1104 can include at least one electrode and/or sensor 1106.

Having leads directly touch the tissue of a patient can be undesirable and can damage the tissue. Consequently, the distal tip 1106 of lead 802 can include an inflatable balloon 1108. Balloon 1108 can be inflated when the distal tip 1106 of lead 802 encounters an anatomical structure obstructing its path, or prior to moving near sensitive anatomy during lead delivery. The balloon may be configured to divert the obstacle and/or the lead to facilitate circumventing the anatomical structure or may indicate that the lead has reached its intended destination.

To inflate the balloon, lead 802 can include a gas channel 1110. At the end of gas channel 1110 there can be a valve 1112. Valve 1112 can be controlled through physical manipulation of a valve actuator, through electrical stimulation, through pressure changes in gas channel 1110 and/or controlled in other ways. In some variations, the valve 1112 may be configured at the proximal end of the lead 802.

When positioning lead 802 into a patient, lead 802 may cause damage to, or perforations of, the soft tissues of the patient. When lead 802 is being installed into a patient, distal tip 1104 of lead 802 can encounter soft tissue of the patient that should be avoided. In response to encountering the soft tissue of the patient, gas can be introduced into gas channel 1110, valve 1112 can be opened and balloon 1108 can be inflated, as shown in FIG. 11B. Inflating balloon 1108 can cause the balloon to stretch and push into the soft tissue of the patient, moving the soft tissue out of the way and/or guiding distal tip 1104 of lead 802 around the soft tissue. When distal tip 1104 of lead 802 has passed by the soft tissue obstruction, valve 1112 can be closed and the balloon deflated.

In some variations, a delivery component or system is used to facilitate delivery of a lead, such as lead 802, to the desired location. FIG. 12 is an illustration 1200 of an exemplary delivery system for a lead having features consistent with the present disclosure. An example of the delivery system is an expandable sheath 1202. Expandable sheath 1202 can be inserted into the patient at the desired insertion point, identified using one or more of the technologies described herein. Expandable sheath 1202 can include a tip 1204. In some variations, tip 1204 may be radiopaque. A radiopaque tip 1204 may be configured to facilitate feeding of the expandable sheath 1202 to a desired location using one or more radiography techniques known in the art and described herein. Such radiography techniques can include fluoroscopy, CT scan, and the like.

Tip 1204 can include one or more sensors for facilitating the placement of the lead. The sensors included in tip 1204 of the expandable sheath 1202 can be the same or similar to the sensors described herein for monitoring physiological characteristics of the body and other characteristics for facilitating positioning of a lead in a body.

Expandable sheath 1202 can include a channel 1206 running through a hollow cylinder 1208 of expandable sheath 1202. When tip 1204 of expandable sheath 1202 is at

the desired location, gas or liquid can be introduced into hollow cylinder 1208. The gas or liquid can be introduced into hollow cylinder 1208 through a first port 1210. Hollow cylinder 1208 can expand, under the pressure of the gas or liquid, causing channel 1206 running through hollow cylinder 1208 to increase in size. A lead, such as lead 802 illustrated in FIG. 8A, can be inserted into channel 1206 through a central port 1212. Hollow cylinder 1208 can be expanded until channel 1206 is larger than the lead. In some variations, channel 1206 can be expanded to accommodate leads of several French sizes. Once the lead is in the desired place, expandable sheath 1202 can be removed, by allowing the lead to pass through channel 1206. In some variations, liquid or gas can be introduced into or removed from channel 1006 through a second port 1214.

Using expandable sheath 1202 can provide an insertion diameter smaller than the useable diameter. This can facilitate a reduction in the risk of damage to tissues and vessels within the patient when placing the lead.

When electricity is brought within the vicinity of muscle tissue, the muscle will contract. Consequently, having a lead for carrying electrical pulses traversing through intercostal muscle tissue may cause the intercostal muscle tissue to contract. Electrical insulation can be provided in the form of a receptacle disposed in the intercostal muscle, where the receptacle is configured to electrically insulate the intercostal muscle from the lead.

FIG. 13 is an illustration 1300 of an intercostal space 1302 associated with the cardiac notch of the left lung with an exemplary lead receptacle 1304 having features consistent with the present disclosure. Lead receptacle 1304 can facilitate the placement of leads, and/or other instruments and avoid the leads and/or instruments physically contacting the intercostal tissue. When the distal end of the lead is positioned to terminate in the intercostal muscle, the lead can be passed through lead receptacle 1304 that has been previously placed within the patient's intercostal muscles. Lead receptacle 1304 can be configured to be electrically insulated so that electrical energy emanating from the lead will not stimulate the surrounding intercostal and skeletal muscle tissue, but will allow the electrical energy to traverse through and stimulate cardiac tissue.

The intercostal space 1302 is the space between two ribs, for example, rib 1306a and rib 1306b. Intercostal muscles 1308a, 1308b and 1308c can extend between two ribs 1306a and 1306b, filling intercostal space 1302. Various blood vessels and nerves can run between the different layers of intercostal muscles. For example, intercostal vein 1310, intercostal artery 1312, the intercostal nerve 1314 can be disposed under a flange 1316 of upper rib 1306a and between the innermost intercostal muscle 1308c and its adjacent intercostal muscle 1308b. Similarly, collateral branches 1318 can be disposed between the innermost intercostal muscle 1308c and its adjacent intercostal muscle 1308b.

The endothoracic fascia 1320 can abut the innermost intercostal muscle 1308c and separate the intercostal muscles from the parietal pleura 1322. The pleural cavity 1324 can be disposed between the parital pleura 1322 and the visceral pleura 1326. The visceral pleura 1326 can abut the lung 1328.

FIG. 14 is an illustration 1400 of an exemplary lead fixation receptacle 1304 illustrated in FIG. 13, having features consistent with the present disclosure.

Lead receptacle 1304 may comprise a cylindrical body, or lumen 1328, from an outer side of an outermost intercostal muscle to an inner side of an innermost intercostal muscle of

an intercostal space. Lumen **1328** may be configured to support a lead traversing through it. Lumen **1328** may comprise an electrically insulating material configured to inhibit traversal of electrical signals through walls of lumen **1328**. In some variations, end **1336** of the receptacle **1304** may pass through the innermost intercostal muscle **1308c**. In some variations, end **1338** of receptacle **1304** can pass through outermost intercostal muscle **1308a**.

Lumen **1328** can terminate adjacent the pleural space **1324**. In some variations, the lumen **1328** can terminate in the mediastinum. In some variations, receptacle **1304** can be configured to be screwed into the intercostal muscles **1308a**, **1308b**, and **1308c**. Receptacle **1304** can also be configured to be pushed into the intercostal muscles **1308a**, **1308b** and **1308c**.

Lead receptacle **1304** may include a fixation flange **1330a**. Fixation flange **1330a** may be disposed on the proximal end of the lumen **1328** and configured to abut the outermost intercostal muscle **1308a**. Lead receptacle **1304** may include a fixation flange **1330b**. Fixation flange **1330b** can be disposed on the distal end of the lumen **1328** and configured to abut the outermost intercostal muscle **1308c**. Lead receptacle **1304** can be implanted into the intercostal muscles **1308a**, **1308b**, and **1308c** by making an incision in the intercostal muscles **1308a**, **1308b**, and **1308c**, stretching the opening and positioning lead receptacle **1304** into the incision, taking care to ensure that the incision remains smaller than the outer diameter of flanges **1330a** and **1330b**. In some variations flanges **1330a** and **1330b** can be configured to be retractable allowing for removal and replacement of the lead fixation receptacle **1304**.

Lead receptacle **1304** can be fixed in place by using just flanges **1330a** and **1330b**. Lead receptacle **1304** may also be fixed in place by using a plurality of surgical thread eyelets **1332**. Surgical thread eyelets **1332** can be configured to facilitate stitching lead receptacle **1304** to the intercostal muscles **1308a** and **1308c** to fix lead receptacle **1304** in place.

Receptacle **1304** can include an internal passage **1334**. Internal passage **1334** can be configured to receive one or more leads and facilitate their traversal through the intercostal space **1302**.

Lead receptacle **1304** can be formed from an electrically insulating material. The electrically insulating material can electrically isolate the intercostal muscles **1308a**, **1308b** and **1308c** from the leads traversing through lead receptacle **1304**.

Lead receptacle **1304** can be formed from materials that are insulative. The material can include certain pharmacological agents. For example, antibiotic agents, immunosuppressive agents to avoid rejection of lead receptacle **1304** after implantation, and the like. In some variations, lead receptacle **1304** can be comprised of an insulative polymer coated or infused with an analgesic. In some variations, the lead receptacle **1304** can be comprised of an insulative polymer coated or infused with an anti-inflammatory agent. The polymer can be coated or infused with other pharmacological agents known to one skilled in the art to treat acute adverse effects from the implantation procedure or chronic adverse effects from the chronic implantation of the lead or receptacle within the thoracic cavity.

FIG. **15** is an illustration of lead receptacle **1304** having features consistent with the present disclosure. Lead fixation receptacle can comprise a septum **1340**, or multiple septums disposed transversely within lumen **1338**. Septum **1340** can be selectively permeable such that when a lead is inserted through septum **1340**, septum **1340** can be configured to

form a seal around the lead traversing through lumen **1338** to prevent the ingress or egress of gas, fluid, other materials, and the like, through lumen **1338**. Septum **1340** may optionally permit the egress of certain gas and fluid but prevent ingress of such materials through lumen **1338**.

In some variations, the lead receptacle can comprise multiple lumens. For example, lead receptacle can comprise a second lumen configured to traverse from an outermost side of an outermost intercostal muscle to an innermost side of an innermost intercostal muscle. Second lumen can be configured to facilitate dispensing of pharmacological agents into the thorax of the patient.

The lumens for such a lead receptacle can be used for differing purposes in addition to the passage of a single lead into the pleural space or mediastinum. The multiple lumens can provide access for multiple leads to be passed into the pleural space or mediastinum.

FIG. **16** is an illustration of an exemplary lead fixation receptacle **1342** having features consistent with the present disclosure. Lead fixation receptacle **1342** can include a first lumen **1344**, similar to lumen **1338** of the lead receptacle **1304** illustrated in FIGS. **14** and **15**. Lead fixation receptacle **1342** can include an additional lumen **1346**. Additional lumen **1346** can be provided as a port to provide access to the thoracic cavity of the patient. Access can be provided to facilitate dispensing of pharmacological agents, such as pharmacological agents to treat various adverse effects such as infection or pain in the area surrounding lead receptacle **1342**, pleural space, mediastinum, and/or other areas surrounding the thoracic cavity of the patient. Additional lumen **1346** can provide access for treatment of other diseases or disorders affecting organs or other anatomical elements within the thoracic cavity. For example, additional lumen **1346** can facilitate the evacuation of gas or fluid from the thorax, and the like.

The lead receptacle as described with reference to FIGS. **13-16** can be fixated to cartilage, or bone within the thoracic cavity. In some variations, the lead receptacle can be configured to be disposed between the intercostal muscles and a rib, thereby potentially reducing damage to the intercostal muscles caused by its insertion. The lead receptacle can be in passive contact with tissue surrounding the cardiac notch. For example, the lead receptacle can abut the superficial fascia on the outermost side and the endothoracic fascia or the parietal pleura on the innermost side.

In some variations, the lead receptacle can be actively fixed into position using one end of the lead receptacle. For example, only one flange can include surgical thread holes to facilitate sewing of the flange into the intercostal muscles.

Active fixation, whether at flanges, or along the lumen of the lead fixation receptacle, can include, for example, the use of tines, hooks, springs, screws, flared wings, flanges and the like. Screws can be used to screw the lead fixation receptacle into bone or more solid tissues within the thoracic cavity. Hooks, tines, springs, and the like, can be used to fix the lead fixation receptacle into soft tissues within the thoracic cavity.

In some variations the lead receptacle can be configured to facilitate in-growth of tissue into the material of which the lead fixation receptacle is comprised. For example, the lead fixation receptacle can be configured such that bone, cartilage, intercostal muscle tissue, or the like, can readily grow into pockets or fissures within the surface of the lead receptacle. Facilitating the growth of tissue into the material of the lead receptacle can facilitate fixation of the receptacle.

In some variations, the receptacle can be configured to actively fix between layers of the intercostal muscle. With

reference to FIG. 13, the layered nature of the intercostal muscle layers **1308a**, **1308b** and **1308c** can be used to facilitate fixation of the lead receptacle into the intercostal space. For example, flanges can be provided that extend between the intercostal muscle layers. Incisions can be made at off-set positions at each layer of intercostal muscle such that when the lead receptacle is inserted through the incisions, the intercostal muscles apply a transverse pressure to the lead receptacle keeping it in place. For example, a first incision can be made in the first intercostal muscle layer **1308a**, a second incision can be made in the second intercostal muscle layer **1308b**, offset from the first incision, and a third incision can be made to the third intercostal muscle layer **1308c** in-line with the first incision. Inserting the lead receptacle through the incisions, such that the lead receptacle is situated through all three incisions, will cause the second intercostal muscle layer **1308b** to apply a transverse pressure to the lead receptacle that is countered by the first intercostal muscle layer **1308a** and the third intercostal muscle layer **1308c**, facilitating keeping the lead receptacle in place.

Sensing and detection will be performed using one or more available signals to determine when pacing should be delivered or inhibited. Cardiac signals will be measured from one or more electrodes. Additional non-cardiac sensors may also be used to enhance the accuracy of sensing and detection. Such sensors include, but are not limited to rate response sensors, posture/positional sensors, motion/vibration sensors, myopotential sensors and exogenous noise sensors. One or more algorithms will be utilized to make decisions about pacing delivery and inhibition. Such algorithms will evaluate available signal attributes and relationships, including but not limited to analysis of morphology, timing, signal combinations, signal correlation, template matching or pattern recognition.

A pulse generator, such as pulse generator **102** illustrated in FIG. 1, can be configured to monitor physiological characteristics and physical movements of the patient. Monitoring can be accomplished through sensors disposed on, or in, the pulse generator, and/or through sensors disposed on one or more leads disposed within the body of the patient. The pulse generator can be configured to monitor physiological characteristics and physical movements of the patient to properly detect heart arrhythmias, dyssynchrony, and the like.

Sensor(s) can be configured to detect an activity of the patient. Such activity sensors can be contained within or on the housing of the pulse generator, such as pulse generator **102** illustrated in FIG. 1. Activity sensors can comprise one or more accelerometers, gyroscopes, position sensors, and/or other sensors, such as location-based technology, and the like. Sensor information measured by the activity sensors can be cross-checked with activity information measured by any concomitant devices.

In some variations, an activity sensor can include an accelerometer. The accelerometer can be configured to detect accelerations in any direction in space. Acceleration information can be used to identify potential noise in signals detected by other sensor(s), such as sensor(s) configured to monitor the physiological characteristics of the patient, and the like, and/or confirm the detection of signals indicating physiological issues, such as arrhythmias or other patient conditions.

In some variations, a lead, such as lead **802** in FIG. 8, can be configured to include sensors that are purposed solely for monitoring the patient's activity. Such sensors may not be configured to provide additional assistance during the

implantation procedure. These sensors can include pulmonary, respiratory, minute ventilation, accelerometer, hemodynamic, and/or other sensors. Those sensors known in the art that are used to real-time, or periodically monitor a patient's cardiac activity can be provided in the leads. These sensors are purposed to allow the implanted device to sense, record and in certain instances, communicate the sensed data from these sensors to the patient's physician. In alternative embodiments, the implanted medical device may alter the programmed therapy regimen of the implanted medical device based upon the activity from the sensors.

In some variations, sensors, such as sensors **810** and **812** of FIG. 8A, may be configured to detect the condition of various organs and/or systems of the patient. Sensor(s) **810**, **812** can be configured to detect movement of the patient to discount false readings from the various organs and/or systems. Sensor(s) **810**, **812** can be configured to monitor patient activity. Having a distal end **806** of lead **802** positioned in the cardiac notch abutting the parietal pleura, sensor(s) **810**, **812** can collect information associated with the organs and/or systems of the patient in that area, for example the lungs, the heart, esophagus, arteries, veins and other organs and/or systems. Sensor(s) **810** can include sensors to detect cardiac ECG, pulmonary function, sensors to detect respiratory function, sensors to determine minute ventilation, hemodynamic sensors and/or other sensors. Sensors can be configured independently to monitor several organs or systems and/or configured to monitor several characteristics of a single organ simultaneously. For example, using a first sensor pair, the implanted cardiac pacing system may be configured to monitor the cardiac ECG signal from the atria, while simultaneously, a second sensor pair is configured to monitor the cardiac ECG signal from the ventricles.

A lead disposed in the body of a patient, such as lead **802** of FIG. 8A, can include sensors at other areas along the lead, for example, sensors **812**. The location of sensors **812** along lead **802** can be chosen based on proximity to organs, systems, and/or other physiological elements of the patient. The location of sensors **812** can be chosen based on proximity to other elements of the implanted cardiac pacing system.

Additional leads may be used to facilitate an increase in the sensing capabilities of the implantable medical device. In one embodiment, in addition to at least one lead disposed within the intercostal muscle, pleural space or mediastinum, another lead is positioned subcutaneously and electrically connected to the implantable medical device. The subcutaneously placed lead can be configured to enhance the implantable medical device's ability to sense and analyze far-field signal's emitted by the patient's heart. In particular, the subcutaneous lead enhances the implantable medical device's ability to distinguish signals from particular chambers of the heart, and therefore, appropriately coordinate the timing of the required pacing therapy delivered by the implantable medical device.

Additional leads in communication with the implantable medical device or pulse generator, and/or computing device, can be placed in other areas within the thoracic cavity in order to enhance the sensing activity of the heart, and to better coordinate the timing of the required pacing therapy delivered by the implantable medical device. In certain embodiments, these additional leads are physically attached to the implantable medical device of the present disclosure.

The leads used to deliver therapeutic electrical pulses to pace the heart can comprise multiple poles. Each pole of the lead can be configured to deliver therapeutic electrical

pulses and/or obtain sensing information. The different leads can be configured to provide different therapies and/or obtain different sensing information. Having multiple sensors at multiple locations can increase the sensitivity and effectiveness of the provided therapy.

FIG. 8B is an illustration **800b** of an exemplary lead **802** having features consistent with the present disclosure. In some variations, lead **802** can comprise a yoke **816**. The yoke can be configured to maintain a hermetically sealed housing for the internal electrical cables of lead **802**, while facilitating splitting of the internal electrical cables into separate end-leads **818a**, **818b**, **818c**. Yoke **816** can be disposed toward distal end of lead **802**. While three end-leads **818a**, **818b**, **818c** are illustrated in FIG. 8B, the current disclosure contemplates fewer end-leads as well as a greater number of end-leads emanating from yoke **816**.

The different end-leads **818a**, **818b**, **818c**, can include different electrodes and/or sensors. For example, end-lead **818b** can include an electrode **808b** at the distal end **806b** of end-lead **818b** that differs from electrode **808a** at distal end **806a** of end-lead **818a**. Electrode **808b** can have flanges **820**. Flanges **820** can be configured to act as an anchor, securing the distal end **806b** of end-lead **818b** in position within the patient. Electrode **808b** with flanges **820** can be suitable for anchoring into high-motion areas of the body where end-lead **818b** would otherwise move away from the desired location without the anchoring effect provided by flanges **820**. Similarly, electrode **808c** at the distal end **806c** of end-lead **818c** can be configured for a different function compared to the electrodes at the end of other end-leads.

Lead **802** can be a multi-pole lead. Each pole can be electronically isolated from the other poles. The lead **802** can include multiple isolated poles, or electrodes, along its length. The individual poles can be selectively activated. The poles may include sensors for monitoring cardiac or other physiological conditions of the patient, or electrodes for deliver therapy to the patient.

The sensing characteristics of a patient can change over time, or can change based on a patient's posture, a multi-pole lead permits the implantable medical device facilitate monitoring a patient's state through multiple sensing devices, without requiring intervention to reposition a lead. Furthermore, a multi-pole lead can be configured to facilitate supplementary sensing and therapy delivery vectors, such as sensing or stimulating from one pole to a plurality of poles, sensing or stimulating from a plurality of poles to a single pole, or sensing or stimulating between a plurality of poles to a separate plurality of poles. For example, should one particular vector be ineffective at treating a particular arrhythmia, the implantable medical device, or pulse generator, can be configured to switch vectors between the poles on the lead and reattempt therapy delivery using this alternative vector. This vector switching is applicable for sensing. Sensing characteristics can be monitored, and if a sensing vector becomes ineffective at providing adequate sensing signals, the implantable medical device can be configured to switch vectors or use a combination of one or more sensor pairs to create a new sensing signal.

In some variations, at yoke **816**, each of the poles of the multi-pole lead can be split into their separate poles. Each of the end-leads emanating from the yoke **816** can be associated with a different pole of the multi-pole lead.

Some of the end-leads emanating from yoke **816** can be configured for providing sensor capabilities of and/or therapeutic capabilities to the patient's heart. Others of the end-leads emanating from yoke **816** can be configured to provide sensor capabilities and/or therapeutic capabilities

that are unrelated to the heart. Similarly, the cardiac pacing system herein described can include leads **802**, or medical leads, that provide functionality unrelated to the heart.

In some variations, the lead can be bifurcated. A bifurcated lead can comprise two cores within the same lead. In some variations, the different cores of the bifurcated lead can be biased to bend in a predetermined manner and direction upon reaching a cavity. Such a cavity can, for example, be the mediastinum. Bifurcated lead cores can be comprised of shape memory materials, for example, nitinol or other material known in the art to deflect in a predetermined manner upon certain conditions. The conditions under which the bifurcated lead cores will deflect include electrical stimulation, pressure, temperature, or other conditions. In some variations, each core of the bifurcated lead can be configured so that it is steerable by the physician, or an automated system, to facilitate independent advancement of each core of the bifurcated lead, in different directions.

In some variations, sensors from the cardiac pacing system may be selected to optimize sensing characteristics of the cardiac signals. Sensing signals, comprised from one or more sensor pairs may be selected via manual operation of the programming system or automatic operation of the implanted cardiac pacing system. Sensing signals may be evaluated using one of several characteristics including signal amplitude, frequency, width, morphology, signal-to-noise ratio, and the like.

The cardiac pacing system can be configured to use multiple sensors to generate one or more input signals, optionally apply filtering of varying levels to these signals, perform some form of verification of acceptance upon the signals, use the signals to measure levels of intrinsic physiological activity to, subsequently, make therapy delivery decisions. Methods to perform such activities in part or in total include hardware, software, and/or firmware based signal filters, signal amplitude/width analysis, timing analysis, morphology analysis, morphological template comparison, signal-to-noise analysis, impedance analysis, acoustic wave and pressure analysis, or the like. The described analyses may be configured manually via the programming system or via automatic processes contained with the operation software of the cardiac pacing system.

While components have been described herein in their individual capacities, it will be readily appreciated the functionality of individually described components can be attributed to one or more other components or can be split into separate components. This disclosure is not intended to be limiting to the exact variations described herein, but is intended to encompass all implementations of the presently described subject matter.

In the descriptions above and in the claims, phrases such as "at least one of" or "one or more of" may occur followed by a conjunctive list of elements or features. The term "and/or" may also occur in a list of two or more elements or features. Unless otherwise implicitly or explicitly contradicted by the context in which it used, such a phrase is intended to mean any of the listed elements or features individually or any of the recited elements or features in combination with any of the other recited elements or features. For example, the phrases "at least one of A and B;" "one or more of A and B;" and "A and/or B" are each intended to mean "A alone, B alone, or A and B together." A similar interpretation is also intended for lists including three or more items. For example, the phrases "at least one of A, B, and C;" "one or more of A, B, and C;" and "A, B, and/or C" are each intended to mean "A alone, B alone, C alone, A and B together, A and C together, B and C together,

or A and B and C together.” Use of the term “based on,” above and in the claims is intended to mean, “based at least in part on,” such that an unrecited feature or element is also permissible.

The subject matter described herein can be embodied in systems, apparatus, methods, and/or articles depending on the desired configuration. The implementations set forth in the foregoing description do not represent all implementations consistent with the subject matter described herein. Instead, they are merely some examples consistent with aspects related to the described subject matter. Although a few variations have been described in detail above, other modifications or additions are possible. In particular, further features and/or variations can be provided in addition to those set forth herein. For example, the implementations described above can be directed to various combinations and subcombinations of the disclosed features and/or combinations and subcombinations of several further features disclosed above. In addition, the logic flows depicted in the accompanying figures and/or described herein do not necessarily require the particular order shown, or sequential order, to achieve desirable results. Other implementations may be within the scope of the following claims.

What is claimed is:

- 1. A method of delivering a lead comprising: advancing into a patient a lead for delivering electrical stimuli to a heart including an accelerometer configured to facilitate delivery of the lead to a desired location within a mediastinum of the patient, proximate the heart but not physically in contact with the heart or pericardium; and determining a location of a distal end of the lead in the patient utilizing the accelerometer, wherein the location is not in the heart or pericardium.
- 2. The method of claim 1, wherein the accelerometer is disposed at a distal end of the lead.
- 3. The method of claim 1, further comprising: receiving movement information from the accelerometer during advancement of the lead; wherein the determining of the location of the distal end of the lead utilizes the movement information received from the accelerometer.
- 4. The method of claim 3, wherein the movement information is received continuously during at least a portion of the advancement of the lead.
- 5. The method of claim 4, further comprising: determining a continuous path taken by the lead based on the movement information; wherein the determining the location of the distal end of the lead in the patient utilizes the determined continuous path.
- 6. The method of claim 1, further comprising: detecting acoustic pressure waves during the advancing of the lead; wherein determining the location of the distal end of the lead includes comparing the detected acoustic pressure waves with a known model.
- 7. The method of claim 6, wherein the acoustic pressure waves are generated by an anatomical structure of the patient.
- 8. The method of claim 6, wherein the anatomical structure of the patient comprises a blood-filled vessel.
- 9. The method of claim 6, wherein the anatomical structure of the patient is a heart.

- 10. The method of claim 1, further comprising: generating artificial pressure waves in the patient in a controlled manner; detecting the artificial pressure waves with the accelerometer; wherein the determining of the location of the distal end of the lead includes comparing the detected artificial pressure waves with a known model.
- 11. A cardiac pacing system comprising: a lead configured to electrically couple with a pulse generator and to transmit therapeutic electric pulses to a patient, the at least one lead comprising: at least one accelerometer disposed on the lead and configured to facilitate delivery of the lead to a desired location within a mediastinum of the patient, proximate the heart but not physically in contact with the heart or pericardium; at least one programmable processor; and a non-transitory machine-readable medium storing instructions which, when executed by the at least one programmable processor, cause the at least one programmable processor to perform operations comprising: determining a location of a distal end of the lead in the patient utilizing the accelerometer, wherein the location is not in the heart or pericardium.
- 12. The cardiac pacing system of claim 11, wherein the accelerometer is disposed at a distal end of the lead.
- 13. The cardiac pacing system of claim 11, wherein the accelerometer is configured to transmit movement information during advancement of the lead; and wherein the cardiac pacing system is configured to determine the location of the distal end of the lead utilizing movement information transmitted by the accelerometer.
- 14. The cardiac pacing system of claim 13, wherein the accelerometer is configured to continuously transmit during at least a portion of the advancement of the lead.
- 15. The cardiac pacing system of claim 14, wherein the system is configured to determine a continuous path taken by the lead based on the movement information; and wherein determining the location of the distal end of the lead utilizes the continuous path.
- 16. The cardiac pacing system of claim 11, wherein the accelerometer is configured to detect acoustic pressure waves during delivery of the lead; and wherein the system is configured to determine the location of the distal end of the lead at least by comparing the detected acoustic pressure waves with a known model.
- 17. The cardiac pacing system of claim 16, wherein the acoustic pressure waves are generated by an anatomical structure of the patient.
- 18. The cardiac pacing system of claim 17, wherein the anatomical structure of the patient comprises a blood-filled vessel.
- 19. The cardiac pacing system of claim 17, wherein the anatomical structure of the patient is a heart.
- 20. The cardiac pacing system of claim 11, wherein the accelerometer is configured to detect artificial pressure waves generated in a controlled manner in the patient, and wherein the cardiac pacing system is configured to determine the location of the distal end of the lead at least by comparing the detected artificial pressure waves with a known model.