



US009687875B2

(12) **United States Patent**
Molin

(10) **Patent No.:** **US 9,687,875 B2**
(45) **Date of Patent:** **Jun. 27, 2017**

(54) **CURING APPARATUS EMPLOYING ANGLED UVLEDS**

(71) Applicant: **Draka Comteq B.V.**, Amsterdam (NL)

(72) Inventor: **Denis Molin**, Draveil (FR)

(73) Assignee: **Draka Comteq, B.V.**, Amsterdam (NL)

(*) Notice: Subject to any disclaimer, the term of this patent is extended or adjusted under 35 U.S.C. 154(b) by 109 days.

(21) Appl. No.: **14/886,494**

(22) Filed: **Oct. 19, 2015**

(65) **Prior Publication Data**
US 2016/0038970 A1 Feb. 11, 2016

Related U.S. Application Data

(62) Division of application No. 13/111,147, filed on May 19, 2011, now Pat. No. 9,187,367.

(60) Provisional application No. 61/346,806, filed on May 20, 2010, provisional application No. 61/351,151, filed on Jun. 3, 2010.

(51) **Int. Cl.**
B05D 3/06 (2006.01)
B05D 7/20 (2006.01)
C03C 25/62 (2006.01)
C03C 25/12 (2006.01)

(52) **U.S. Cl.**
CPC **B05D 3/067** (2013.01); **C03C 25/12** (2013.01); **C03C 25/6226** (2013.01); **B05D 7/20** (2013.01)

(58) **Field of Classification Search**
CPC C03C 25/12; C03C 25/622; C03C 25/106; B05D 3/067; B05D 7/20; C08J 7/12
USPC 427/595, 558, 513; 118/642; 385/128
See application file for complete search history.

(56) **References Cited**

U.S. PATENT DOCUMENTS

3,737,051 A	6/1973	Horino
3,784,836 A	1/1974	Tolliver
3,800,160 A	3/1974	Ishizawa et al.
3,819,929 A	6/1974	Newman
3,983,039 A	9/1976	Eastland
4,010,374 A	3/1977	Ramler
4,033,263 A	7/1977	Richmond
4,070,499 A	1/1978	Ramier et al.
4,145,136 A	3/1979	Takahashi
4,309,452 A	1/1982	Sachs

(Continued)

FOREIGN PATENT DOCUMENTS

CN	1396134 A	2/2003
DE	2911410 A1	9/1980

(Continued)

OTHER PUBLICATIONS

Davidson, Michael. "Fundamentals of Light—Emitting Diodes" *Zeiss microscopy* (2008), online at <http://zeiss-campus.magnet.fsu.edu/print/lightsources/leds-print.html>.*

(Continued)

Primary Examiner — Dah-Wei D Yuan

Assistant Examiner — Jose Hernandez-Diaz

(74) *Attorney, Agent, or Firm* — Additon, Higgins & Pendleton, P.A.

(57) **ABSTRACT**

A UVLED apparatus (and related system and method) provide efficient curing of an optical-fiber coating on a drawn glass fiber. The apparatus employs one or more UVLEDs that emit electromagnetic radiation into a curing space. An incompletely cured optical-fiber coating, which is formed upon a glass fiber, absorbs emitted and reflected electromagnetic radiation to promote efficient curing.

21 Claims, 7 Drawing Sheets

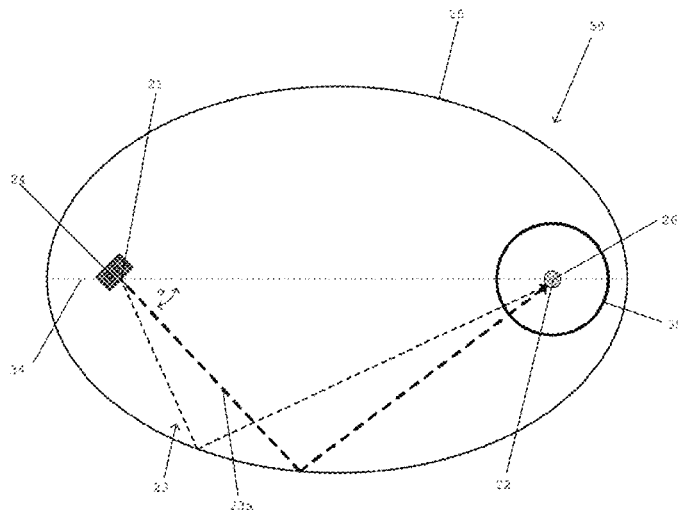

(56)

References Cited

U.S. PATENT DOCUMENTS

4,321,073	A	3/1982	Blair	6,185,394	B1	2/2001	Lee
4,334,733	A	6/1982	Takeshima et al.	6,188,086	B1	2/2001	Masuda et al.
4,479,984	A	10/1984	Levy et al.	6,190,483	B1	2/2001	Yang et al.
4,490,410	A	12/1984	Takiyama et al.	6,200,134	B1	3/2001	Kovac et al.
4,518,628	A	5/1985	Biswas et al.	6,210,802	B1	4/2001	Risch et al.
4,591,724	A	5/1986	Fuse et al.	6,215,931	B1	4/2001	Risch et al.
4,636,405	A	1/1987	Mensah et al.	6,287,672	B1	9/2001	Fields et al.
4,683,525	A	7/1987	Camm	6,314,224	B1	11/2001	Stevens et al.
4,710,638	A	12/1987	Wood	6,321,012	B1	11/2001	Shen
4,761,168	A	8/1988	Blyler, Jr. et al.	6,321,014	B1	11/2001	Overton et al.
4,774,104	A	9/1988	Severijns et al.	6,331,111	B1	12/2001	Cao
4,838,643	A	6/1989	Hodges et al.	6,333,509	B1	12/2001	Lumpp
4,839,513	A	6/1989	Wijtsma	6,334,016	B1	12/2001	Greer, IV
4,844,604	A	7/1989	Bishop et al.	6,338,878	B1	1/2002	Overton et al.
4,853,021	A	8/1989	Soszka et al.	6,345,149	B1	2/2002	Ervin et al.
4,910,107	A	3/1990	Kawanda et al.	6,354,700	B1	3/2002	Roth
4,913,859	A	4/1990	Overton et al.	6,376,568	B1	4/2002	Baudin et al.
4,962,992	A	10/1990	Chapin et al.	6,381,390	B1	4/2002	Hutton et al.
4,980,701	A	12/1990	Contois et al.	6,425,663	B1	7/2002	Eastlund et al.
4,990,971	A	2/1991	Le Creff	6,447,112	B1	9/2002	Hu et al.
5,062,723	A	11/1991	Takeda et al.	6,457,823	B1	10/2002	Cleary et al.
5,146,531	A	9/1992	Shustack	6,463,872	B1	10/2002	Thompson
5,208,645	A	5/1993	Inoue et al.	6,493,491	B1	12/2002	Shen et al.
5,219,623	A	6/1993	Petisce	6,498,355	B1	12/2002	Harrah et al.
5,278,432	A	1/1994	Ignatius et al.	6,501,084	B1	12/2002	Sakai et al.
5,278,482	A	1/1994	Bahn	6,517,218	B2	2/2003	Hochstein
5,366,527	A	11/1994	Amos et al.	6,523,948	B2	2/2003	Matsumoto et al.
5,405,657	A	4/1995	Bastian et al.	6,525,752	B2	2/2003	Vackier et al.
5,418,369	A	5/1995	Moore et al.	6,528,955	B1	3/2003	Powers et al.
5,420,768	A	5/1995	Kennedy	6,536,889	B1	3/2003	Biegelsen et al.
5,427,862	A	6/1995	Ngo et al.	6,561,640	B1	5/2003	Young
5,440,137	A	8/1995	Sowers	6,579,495	B1	6/2003	Maiden
5,440,660	A	8/1995	Dombrowski et al.	6,584,263	B2	6/2003	Fewkes et al.
5,535,673	A	7/1996	Bocko et al.	6,589,716	B2	7/2003	Sweatt et al.
5,574,816	A	11/1996	Yang et al.	6,603,908	B2	8/2003	Dallas et al.
5,633,123	A	5/1997	Hill et al.	6,613,170	B1	9/2003	Ohno et al.
5,634,711	A	6/1997	Kennedy et al.	6,618,538	B2	9/2003	Nechitailo et al.
5,660,461	A	8/1997	Ignatius et al.	6,626,561	B2	9/2003	Carter et al.
5,712,487	A	1/1998	Adachi et al.	6,630,286	B2	10/2003	Kramer
5,717,805	A	2/1998	Stulpin	6,658,184	B2	12/2003	Bourget et al.
5,731,112	A	3/1998	Lewis et al.	6,671,421	B1	12/2003	Ogata et al.
5,733,607	A	3/1998	Mangum et al.	6,683,421	B1	1/2004	Kennedy et al.
5,756,165	A	5/1998	Ali et al.	6,720,566	B2	4/2004	Blandford
5,761,362	A	6/1998	Yang et al.	6,726,317	B2	4/2004	Codos
5,761,367	A	6/1998	Matsumoto	6,741,780	B2	5/2004	Vanpouille et al.
5,762,867	A	6/1998	D'Silva	6,749,446	B2	6/2004	Nechitailo
5,763,003	A	6/1998	Bonicel et al.	6,755,647	B2	6/2004	Melikechi et al.
5,764,263	A	6/1998	Lin	6,768,839	B2	7/2004	Blomquist et al.
5,840,451	A	11/1998	Moore et al.	6,783,810	B2	8/2004	Jin et al.
5,845,034	A	12/1998	Petisce	6,807,906	B1	10/2004	DeMoore et al.
D404,045	S	1/1999	Mandellos	6,835,679	B2	12/2004	Bilanin et al.
D404,046	S	1/1999	Mandellos	6,877,248	B1	4/2005	Cross et al.
D404,409	S	1/1999	Mandellos	6,880,954	B2	4/2005	Ollett et al.
5,857,767	A	1/1999	Hochstein	6,885,035	B2	4/2005	Bhat et al.
5,885,652	A	3/1999	Abbott, III et al.	6,912,347	B2	6/2005	Rossi et al.
5,911,023	A	6/1999	Risch et al.	6,913,794	B2	7/2005	Hoult et al.
5,963,240	A	10/1999	Shinohara et al.	6,922,515	B2	7/2005	Nechitailo et al.
5,973,331	A	10/1999	Stevens et al.	6,929,828	B2	8/2005	Baudin et al.
5,982,968	A	11/1999	Stulpin	6,941,049	B2	9/2005	Risch et al.
5,986,682	A	11/1999	Itou	6,949,591	B1	9/2005	Allard et al.
5,990,498	A	11/1999	Chapnik et al.	7,001,644	B2	2/2006	Baudin et al.
6,013,330	A	1/2000	Lutz	7,022,382	B1	4/2006	Khudyakov et al.
6,018,605	A	1/2000	Mills et al.	7,045,010	B2	5/2006	Sturman, Jr.
6,035,087	A	3/2000	Bonicel et al.	7,080,900	B2	7/2006	Takabayashi et al.
6,066,397	A	5/2000	Risch et al.	7,084,183	B2	8/2006	Fuchs et al.
6,075,595	A	6/2000	Malinen	7,137,696	B2	11/2006	Siegel
6,085,009	A	7/2000	Risch et al.	7,153,015	B2	12/2006	Brukilacchio
6,092,890	A	7/2000	Wen et al.	7,162,128	B2	1/2007	Lovie et al.
6,112,037	A	8/2000	Nagata et al.	7,173,266	B2	2/2007	Katsuki
6,118,130	A	9/2000	Barry	7,175,712	B2	2/2007	Siegel
6,134,363	A	10/2000	Hinson et al.	7,211,299	B2	5/2007	Siegel
6,145,979	A	11/2000	Caiger et al.	7,232,850	B2	6/2007	Johnson et al.
6,163,036	A	12/2000	Taninaka et al.	7,250,611	B2	7/2007	Aguirre et al.
6,175,677	B1	1/2001	Yang et al.	7,322,122	B2	1/2008	Overton et al.
6,181,857	B1	1/2001	Emeterio et al.	7,346,244	B2	3/2008	Gowan et al.
				7,356,234	B2	4/2008	de Montmorillon et al.
				7,399,982	B2	7/2008	Siegel
				7,465,909	B2	12/2008	Siegel
				7,470,921	B2	12/2008	Custer

(56)

References Cited

U.S. PATENT DOCUMENTS

7,483,613	B2	1/2009	Bigot-Astruc et al.	2006/0192829	A1	8/2006	Mills et al.
7,498,065	B2	3/2009	Siegel	2006/0204670	A1	9/2006	Siegel
7,515,795	B2	4/2009	Overton et al.	2006/0216193	A1	9/2006	Johnson et al.
7,526,177	B2	4/2009	Matthijsse et al.	2006/0230969	A1	10/2006	Vosahlo
7,555,186	B2	6/2009	Flammer et al.	2006/0233501	A1	10/2006	Sampson
7,567,739	B2	7/2009	Overton et al.	2006/0237658	A1	10/2006	Waluszko
7,570,852	B2	8/2009	Nothofer et al.	2006/0241259	A1	10/2006	Tanabe et al.
7,587,111	B2	9/2009	de Montmorillon et al.	2006/0245187	A1	11/2006	Scott et al.
7,599,589	B2	10/2009	Overton et al.	2006/0263921	A1	11/2006	Nakamura et al.
7,623,747	B2	11/2009	de Montmorillon et al.	2006/0266955	A1	11/2006	Arvin et al.
7,639,915	B2	12/2009	Parris et al.	2006/0270748	A1	11/2006	Sommerlade et al.
7,646,952	B2	1/2010	Parris	2006/0274421	A1	12/2006	Okamitsu et al.
7,646,954	B2	1/2010	Tatat	2007/0241478	A1	10/2007	Buckley
7,671,346	B2	3/2010	Siegel	2007/0286963	A1	12/2007	Rocha-Alvarez et al.
7,702,204	B2	4/2010	Gonnet et al.	2008/0021126	A1	1/2008	Dietliker et al.
7,724,998	B2	5/2010	Parris et al.	2008/0096115	A1	4/2008	Tanabe et al.
7,775,690	B2	8/2010	Wakalopoulos	2008/0160211	A1	7/2008	Siegel
7,817,891	B2	10/2010	Lavenne et al.	2008/0226272	A1	9/2008	Kasai et al.
7,842,932	B2	11/2010	Knight et al.	2008/0290301	A1	11/2008	Gardner
7,847,269	B2	12/2010	Cekic et al.	2008/0292262	A1	11/2008	Overton et al.
7,889,960	B2	2/2011	de Montmorillon et al.	2009/0032740	A1	2/2009	Smith et al.
7,923,706	B2	4/2011	Brassell et al.	2009/0065715	A1	3/2009	Wainright
7,970,247	B2	6/2011	Barker	2009/0127480	A1	5/2009	Briggs et al.
7,974,507	B2	7/2011	Lovie et al.	2009/0160923	A1	6/2009	Custer
8,314,408	B2	11/2012	Hartsuiker et al.	2009/0175583	A1	7/2009	Overton
2001/0030866	A1	10/2001	Hochstein	2009/0190349	A1	7/2009	Middlemass et al.
2001/0032985	A1	10/2001	Bhat et al.	2009/0214167	A1	8/2009	Lookadoo et al.
2001/0033725	A1*	10/2001	Szum C03C 25/1065 385/128	2009/0218960	A1	9/2009	Lyons et al.
2001/0046652	A1	11/2001	Ostler et al.	2009/0252469	A1	10/2009	Sillard et al.
2001/0048814	A1	12/2001	Lenmann et al.	2009/0279833	A1	11/2009	Overton et al.
2001/0050344	A1	12/2001	Albou	2009/0279835	A1	11/2009	de Montmorillon et al.
2001/0052920	A1	12/2001	Matsumoto et al.	2009/0279836	A1	11/2009	de Montmorillon et al.
2002/0015234	A1	2/2002	Suzuki et al.	2009/0297107	A1	12/2009	Tatat
2002/0016378	A1	2/2002	Jin et al.	2009/0321666	A1	12/2009	Hilgers
2002/0044188	A1	4/2002	Codos	2010/0021170	A1	1/2010	Lumineau et al.
2002/0050575	A1	5/2002	Keogh et al.	2010/0028020	A1	2/2010	Gholami et al.
2002/0074554	A1	6/2002	Sweatt et al.	2010/0067855	A1	3/2010	Barker
2002/0074559	A1	6/2002	Dowling et al.	2010/0067857	A1	3/2010	Lovie et al.
2002/0149660	A1	10/2002	Cleary et al.	2010/0092135	A1	4/2010	Barker et al.
2002/0172913	A1	11/2002	Cao	2010/0092138	A1	4/2010	Overton
2002/0175299	A1	11/2002	Kanie et al.	2010/0092139	A1	4/2010	Overton
2003/0026919	A1	2/2003	Kojima et al.	2010/0092140	A1	4/2010	Overton
2003/0035037	A1	2/2003	Mills et al.	2010/0096564	A1	4/2010	Yang et al.
2003/0109599	A1	6/2003	Kamen	2010/0118388	A1	5/2010	Pastouret et al.
2003/0218880	A1	11/2003	Brukilacchio	2010/0119202	A1	5/2010	Overton
2003/0222961	A1	12/2003	Nakajima	2010/0135623	A1	6/2010	Overton
2004/0011457	A1	1/2004	Kobayashi et al.	2010/0135624	A1	6/2010	Overton et al.
2004/0033317	A1	2/2004	Baudin et al.	2010/0135625	A1	6/2010	Overton
2004/0036188	A1	2/2004	Arboix et al.	2010/0135627	A1	6/2010	Pastouret et al.
2004/0067037	A1	4/2004	Tausch et al.	2010/0142033	A1	6/2010	Regnier et al.
2004/0075065	A1	4/2004	Spivak	2010/0142969	A1	6/2010	Gholami et al.
2004/0090794	A1	5/2004	Oillett et al.	2010/0150505	A1	6/2010	Testu et al.
2004/0114016	A1	6/2004	Yokoyama	2010/0154479	A1	6/2010	Milicevic et al.
2004/0134603	A1	7/2004	Kobayashi et al.	2010/0166375	A1	7/2010	Parris
2004/0135159	A1	7/2004	Siegel	2010/0171945	A1	7/2010	Gholami et al.
2004/0152038	A1	8/2004	Kumagai et al.	2010/0183821	A1	7/2010	Hartsuiker et al.
2004/0156130	A1	8/2004	Powell et al.	2010/0189397	A1	7/2010	Richard et al.
2004/0164325	A1	8/2004	Siegel	2010/0189399	A1	7/2010	Sillard et al.
2004/0166249	A1	8/2004	Siegel	2010/0189400	A1	7/2010	Sillard et al.
2004/0189773	A1	9/2004	Masumi	2010/0202741	A1	8/2010	Ryan et al.
2004/0238111	A1	12/2004	Siegel	2010/0214649	A1	8/2010	Burov et al.
2005/0042390	A1	2/2005	Siegel	2010/0215328	A1	8/2010	Tatat et al.
2005/0051741	A1	3/2005	Hallett et al.	2010/0223803	A1*	9/2010	Karlicek, Jr. B05D 3/061 34/275
2005/0099478	A1	5/2005	Iwase	2010/0242299	A1	9/2010	Siegel
2005/0104946	A1	5/2005	Siegel	2010/0254653	A1	10/2010	Molin et al.
2005/0115498	A1	6/2005	Ingram et al.	2010/0310218	A1	12/2010	Molin et al.
2005/0116176	A1	6/2005	Aguirre et al.	2011/0026889	A1	2/2011	Risch et al.
2005/0152146	A1	7/2005	Owen et al.	2011/0044595	A1	2/2011	Sillard et al.
2005/0222295	A1	10/2005	Siegel	2011/0058781	A1	3/2011	Molin et al.
2005/0228062	A1	10/2005	Wolf et al.	2011/0064367	A1	3/2011	Molin et al.
2005/0234145	A1	10/2005	Sitzmann et al.	2011/0064371	A1	3/2011	Leatherman et al.
2006/0007290	A1	1/2006	Oshima et al.	2011/0069724	A1	3/2011	Richard et al.
2006/0121208	A1	6/2006	Siegel	2011/0069932	A1	3/2011	Overton et al.
2006/0127594	A1	6/2006	Siegel	2011/0091171	A1	4/2011	Tatat et al.
				2011/0116160	A1	5/2011	Boivin et al.
				2011/0123161	A1	5/2011	Molin et al.
				2011/0123162	A1	5/2011	Molin et al.
				2011/0135262	A1	6/2011	Molin et al.

(56)

References Cited

U.S. PATENT DOCUMENTS

2011/0135263	A1	6/2011	Molin et al.
2011/0176782	A1	7/2011	Parris
2011/0188823	A1	8/2011	Sillard et al.
2011/0188826	A1	8/2011	Sillard et al.
2011/0217012	A1	9/2011	Bigot-Astruc et al.
2011/0229101	A1	9/2011	de Montmorillon et al.
2011/0268398	A1	11/2011	Quinn et al.
2011/0268400	A1	11/2011	Lovie et al.
2011/0287195	A1	11/2011	Molin
2012/0009358	A1	1/2012	Gharbi et al.
2012/0014652	A1	1/2012	Parris
2012/0040105	A1	2/2012	Overton
2013/0052364	A1	2/2013	Hartsuiker et al.
2013/0068969	A1	3/2013	Childers

FOREIGN PATENT DOCUMENTS

DE	4226344	A1	2/1994
DE	102004008812	A	9/2005
EP	0228896	A1	8/1987
EP	0854022	A1	7/1998
EP	1139439	A1	10/2001
EP	1138642	B1	7/2004
EP	1250297	B1	10/2005
EP	1764220	A1	3/2007
EP	1599340	B1	9/2007
EP	1861234	A2	12/2007
EP	1921478	A1	5/2008
EP	2085801	A1	8/2009
EP	2388239	A1	11/2011
EP	2418183	A1	2/2012
GB	2166975	A	5/1986
GB	2350321	A	11/2000
GB	2390332	A	1/2004
GB	2396331	A	6/2004
JP	60-126830	A	7/1985
JP	61-010440	A	1/1986
JP	62-026876	A	2/1987
JP	63-182528	A	7/1988
JP	1-107865	A	4/1989
JP	1-124324	A	5/1989
JP	5-213636	A	8/1993
JP	5-323462	A	12/1993
JP	2000-268416	B	9/2000
JP	2001-209980	B	8/2001
JP	2002-248803	A	9/2002
JP	2003-029099	A	1/2003
JP	2003-034557	A	2/2003
JP	2003-034558	A	2/2003
JP	2003-089555	A	3/2003
JP	2005-129662	B	5/2005
JP	2010-117526	A	5/2010
JP	2010-117527	A	5/2010
WO	01/11426	A1	2/2001

WO	02/93265	A1	11/2002
WO	03/096387	A2	11/2003
WO	2004/002746	A1	1/2004
WO	2004/011848	A2	2/2004
WO	2004/081475	A2	9/2004
WO	2005/068509	A1	7/2005
WO	2005/068510	A1	7/2005
WO	2005/082548	A2	9/2005
WO	WO 2005082548	A2 *	9/2005
WO	2005/100408	A1	10/2005
WO	2006/096061	A1	9/2006
WO	2006/101519	A3	9/2006
WO	2006/101526	A3	9/2006
WO	2008/040650	A2	4/2008
WO	2009/062131	A1	5/2009
WO	2010/077132	A1	7/2010

..... B05D 7/20

OTHER PUBLICATIONS

Moreno et al. Modeling the radiation pattern of LEDs. Optics Express vol. 16, No. 3, 2008. pp. 1808-1819.*

Overton, U.S. Appl. No. 61/372,312, "Method and Apparatus Providing Increased UVLED Intensity", filed Aug. 10, 2010, pp. 1-74.

Overton, U.S. Appl. No. 61/112,595, "Microbend Resistant Optical Fiber", filed Nov. 7, 2008, pp. 1-271.

Dutch Search Report in counterpart Dutch Application No. 2004758 dated Jan. 3, 2011, pp. 1-5.

European Search Report in counterpart European Application No. 11166297 dated Sep. 13, 2011, pp. 1-5.

Office Action in counterpart Chinese Application No. 201110132219.3 date Jul. 11, 2014, pp. 1-12.

Davidson, Michael, "Fundamentals of Light-Emitting Diodes" Zeiss Microscopy (2008), online at <http://zeiss-campus.magnet.fsu.edu/print/lightsources/leds-print.html>, pp. 1-12.

Moreno, et al., "Modeling the radiation pattern of LEDs", Optics Express, Feb. 4, 2008, vol. 16, No. 3, pp. 1808-1819.

Office Action in counterpart Chinese Application No. 201110132219.3 date Feb. 9, 2015, pp. 1-3.

U.S. Appl. No. 60/986,737 for a Microbend Resistant Optical Fiber, filed Nov. 9, 2007, (Overton).

U.S. Appl. No. 61/041,484 for a Microbend Resistant Optical Fiber, filed Apr. 1, 2008, (Overton).

CIBA. "Photoinitiators for UV Curing," Formulators' Guide for Coatings, Additives, Switzerland, downloaded from www.mufon.com.tw/Ciba/ciba_guid/photo_uv_2.pdf on May 30, 2012, pp. 1-14.

Bigot-Astruc et al., U.S. Appl. No. 13/175,181, "Single-Mode Optical Fiber", filed Jul. 1, 2011, pp. 1-74.

Dake, et al., "LED Curing Versus Conventional UV Curing Systems: Property Comparisons of Acrylates and Epoxies", DSM Desotech, USA, pp. 1-6.

Ciba, "Photoinitiators for UV Curing," Key Products Selection Guide 2003, Switzerland, pp. 1-8.

* cited by examiner

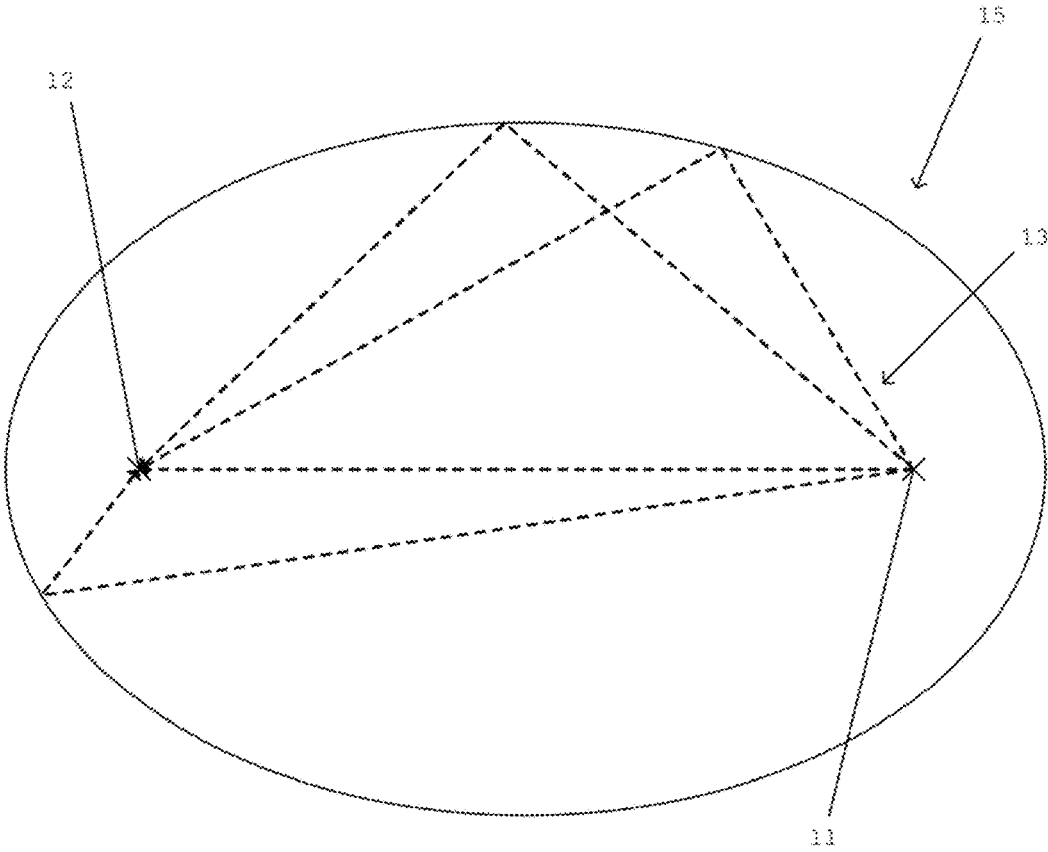

FIG. 1

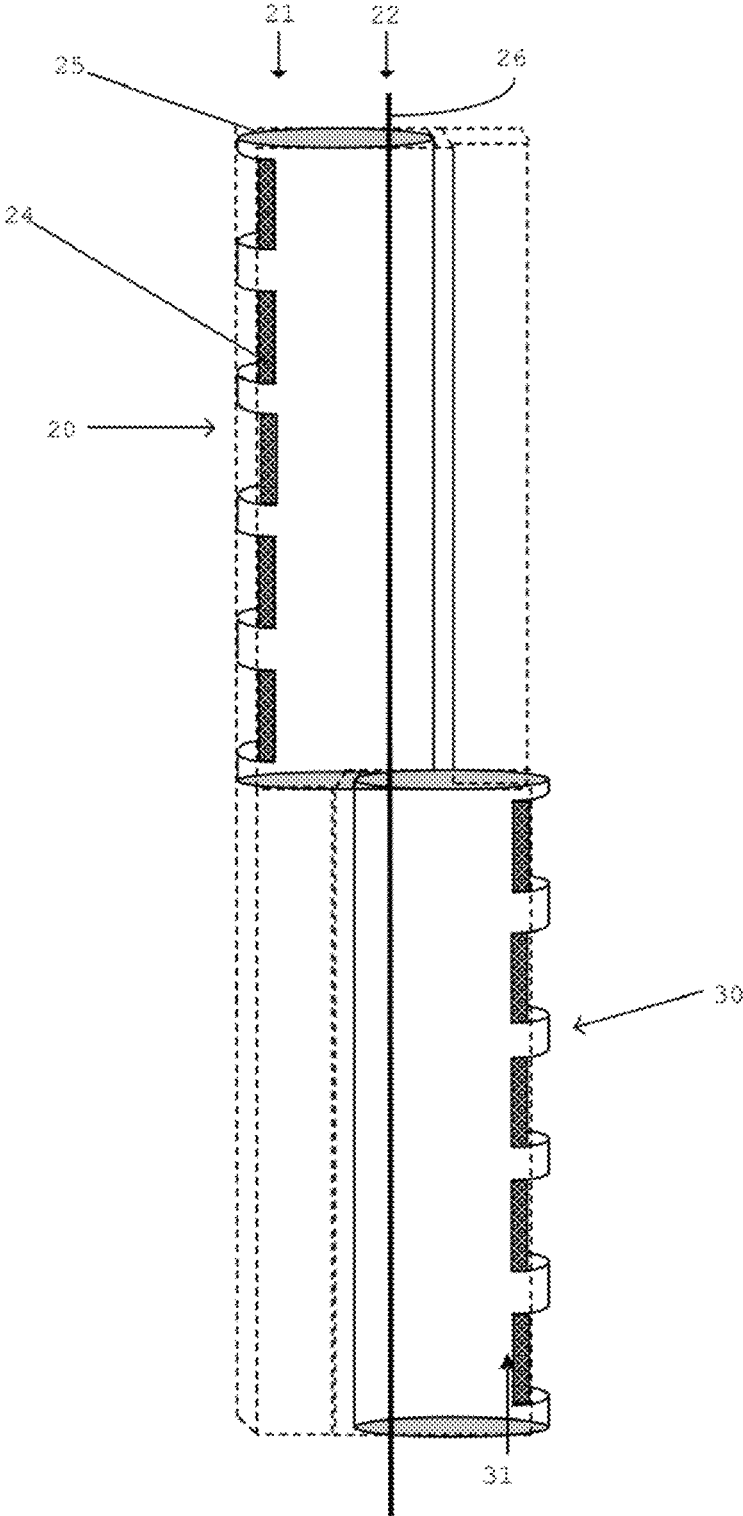

FIG. 2

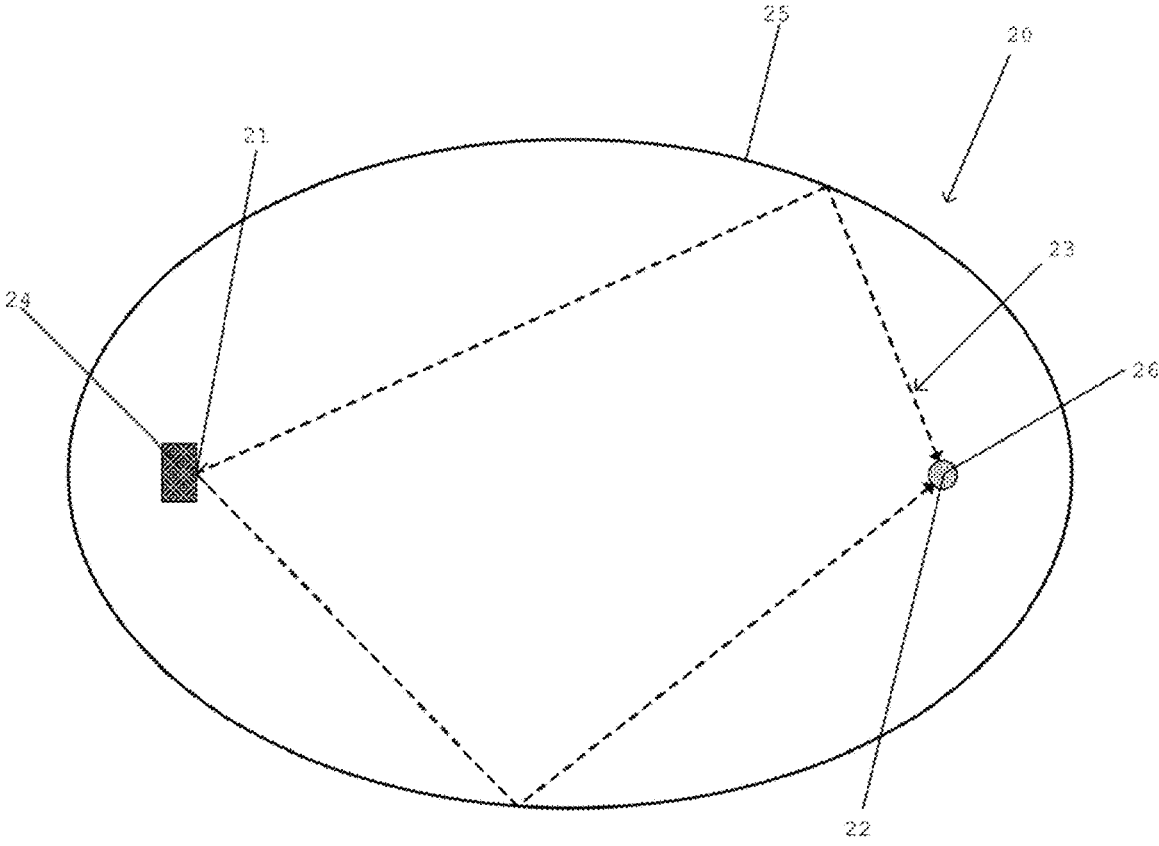

FIG. 3

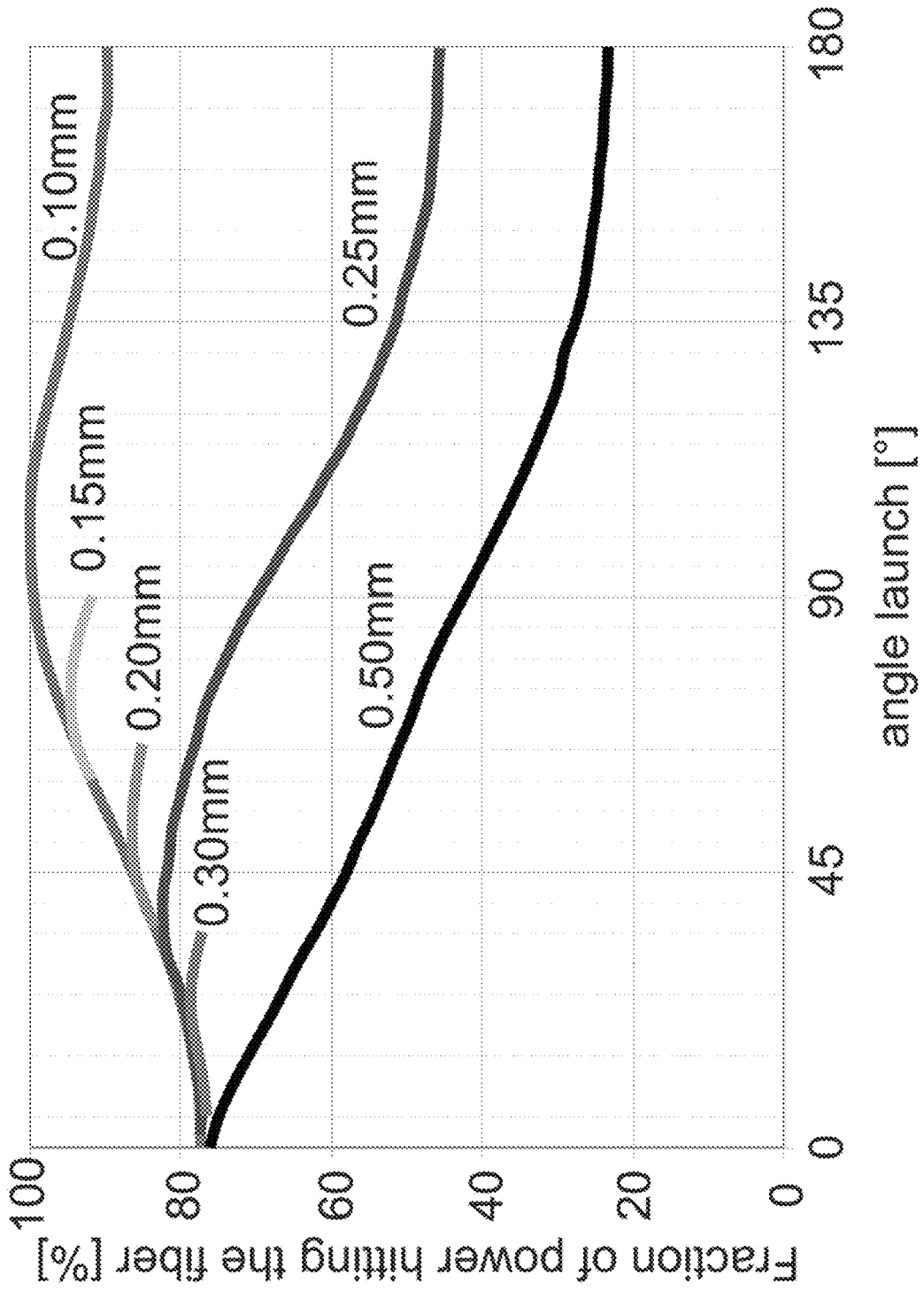

FIG. 4

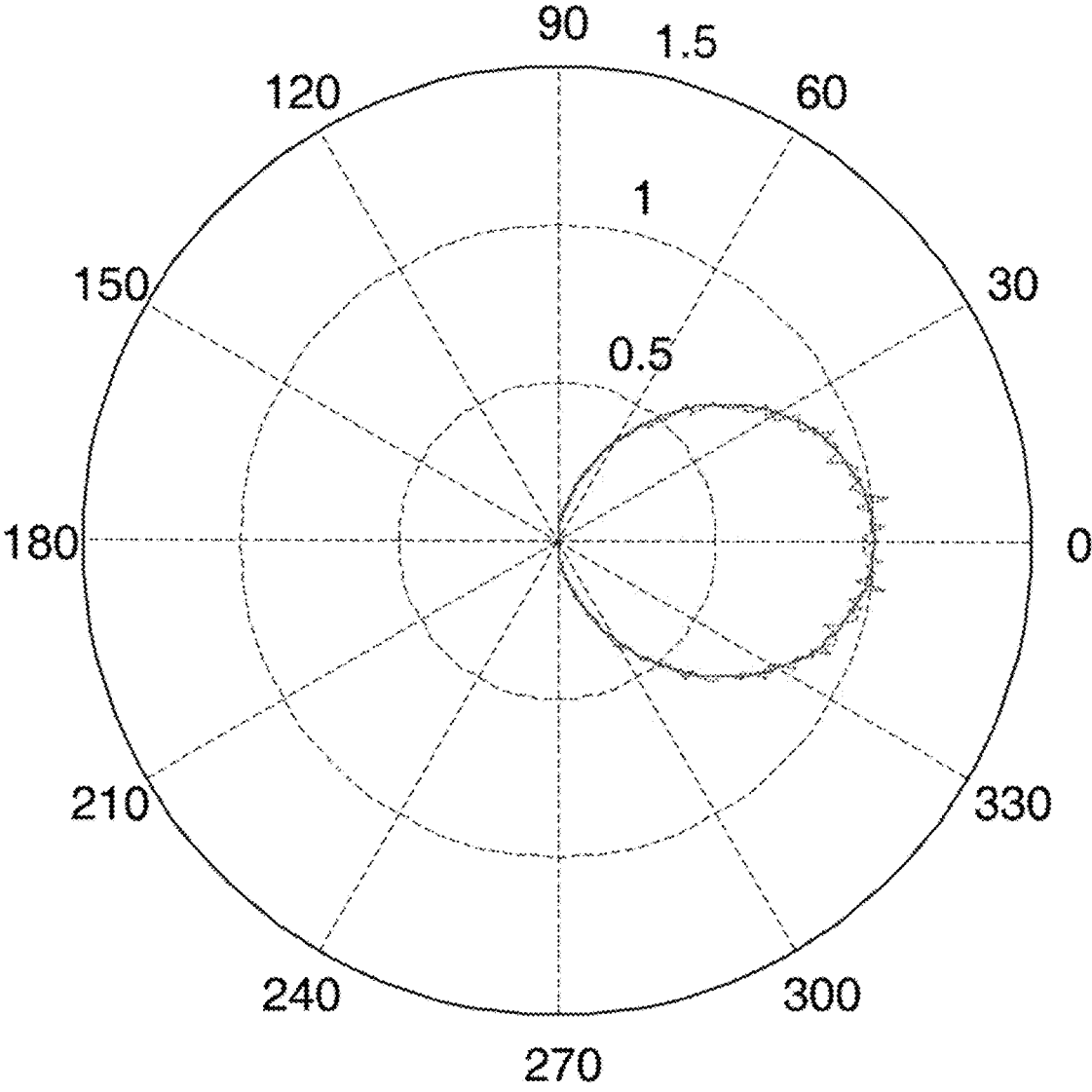

FIG. 6a

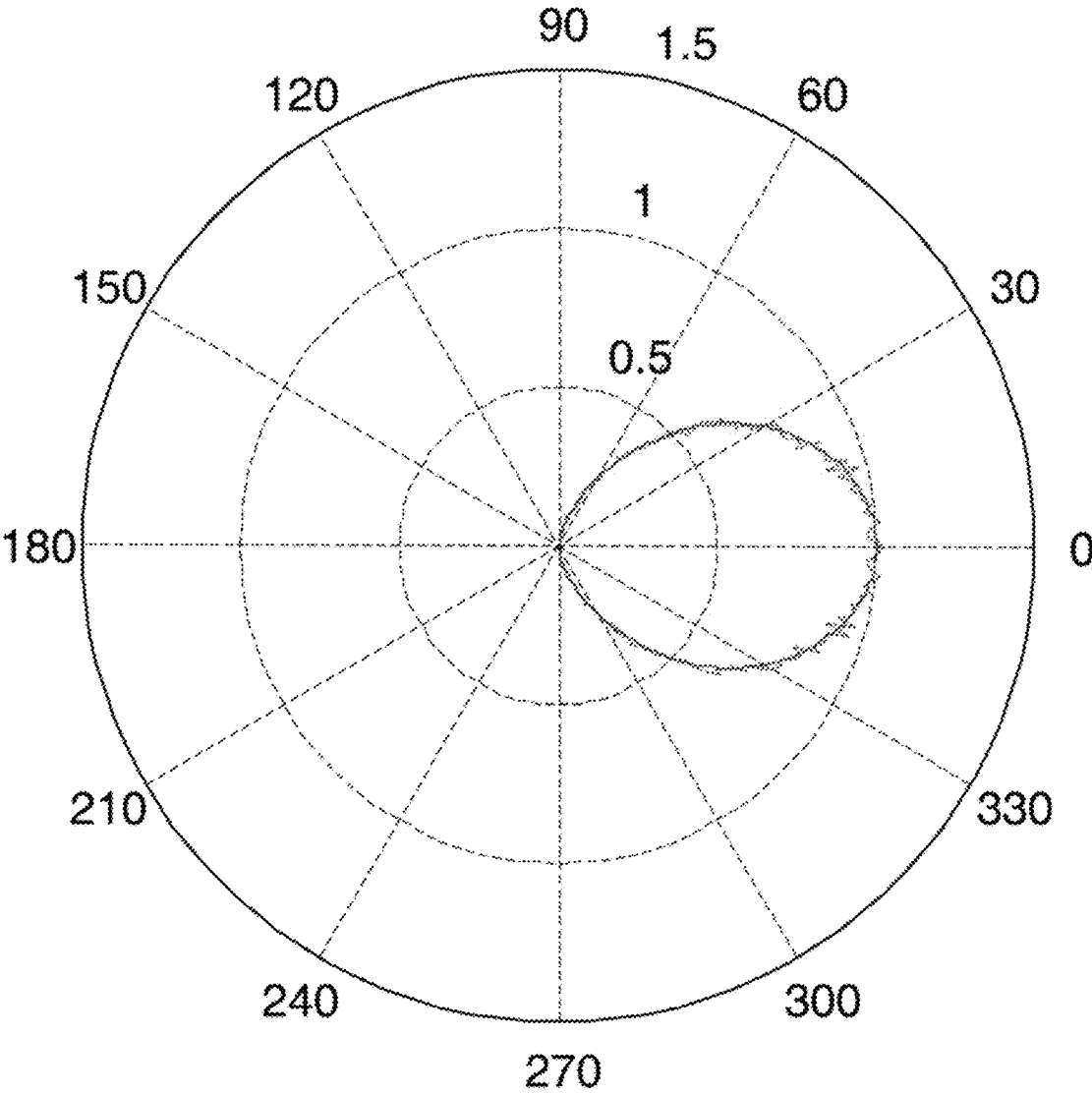

FIG. 6b

1

CURING APPARATUS EMPLOYING ANGLED UVLEDS

CROSS-REFERENCE TO PRIORITY APPLICATIONS

This application is a division of commonly assigned U.S. application Ser. No. 13/111,147 for "Curing Apparatus Employing Angled UVLEDS" (filed May 19, 2011, and published Nov. 24, 2011, as Publication No. 2011/0287195 A1), now U.S. Pat. No. 9,187,367, which itself claims the benefit of U.S. Patent Application No. 61/346,806 for a Curing Apparatus Employing Angled UVLEDS (filed May 20, 2010) and U.S. patent application Ser. No. 61/351,151 for a Curing Apparatus Employing Angled UVLEDS (filed Jun. 3, 2010). Each of the foregoing patent applications and patent application publication is hereby incorporated by reference in its entirety.

FIELD OF THE INVENTION

The present invention embraces an apparatus, a system, and a method for curing coatings on drawn glass fibers.

BACKGROUND

Glass fibers are typically protected from external forces with one or more coating layers. Typically, two or more layers of coatings are applied during the optical-fiber drawing process (i.e., whereby a glass fiber is drawn from an optical preform in a drawing tower). A softer inner coating layer typically helps to protect the glass fiber from microbending. A harder outer coating layer typically is used to provide additional protection and to facilitate handling of the glass fiber. The coating layers may be cured, for example, using heat or ultraviolet (UV) light.

UV curing requires that the coated glass fiber be exposed to high intensity UV radiation. Curing time can be reduced by exposing the coating to higher intensity UV radiation. Reducing curing time is particularly desirable to permit an increase in fiber drawing line speeds and thus optical-fiber production rates.

Mercury lamps (e.g., high pressure mercury lamps or mercury xenon lamps) are commonly used to generate the UV radiation needed for UV curing. One downside of using mercury lamps is that mercury lamps require a significant amount of power to generate sufficiently intense UV radiation. For example, UV lamps used to cure a single coated fiber (i.e., one polymeric coating) may require a collective power consumption of 50 kilowatts.

Another shortcoming of mercury lamps is that much of the energy used for powering mercury lamps is emitted not as UV radiation but rather as heat. Accordingly, mercury lamps must be cooled (e.g., using a heat exchanger) to prevent overheating. In addition, the undesirable heat generated by the mercury lamps may slow the rate at which the optical-fiber coatings cure.

Furthermore, mercury lamps generate a wide spectrum of electromagnetic radiation, such as having wavelengths of less than 200 nanometers and greater than 700 nanometers (i.e., infrared light). Typically, UV radiation having wavelengths of between about 300 nanometers and 400 nanometers is useful for curing UV coatings. Thus, much of the electromagnetic radiation generated by mercury bulbs is wasted (e.g., 90 percent or more). Additionally, glass fibers typically possess a diameter of about 125 microns or less, which, of course, is much smaller than the mercury bulbs.

2

Consequently, most of the UV radiation emitted by the mercury lamps does not reach the glass fiber's uncured coating (i.e., the energy is wasted).

It may thus be advantageous to employ, as an alternative to conventional mercury lamps, UVLEDS to cure glass-fiber coatings. UVLEDS typically require significantly less energy and correspondingly generate much less heat energy than conventional UV lamps.

By way of example, U.S. Pat. No. 7,022,382 (Khudyakov et al.), which is hereby incorporated by reference in its entirety, discloses the use of UV lasers (e.g., continuous or pulsed lasers) for curing optical-fiber coatings.

U.S. Patent Application Publication No. 2003/0026919 (Kojima et al.), which is hereby incorporated by reference in its entirety, discloses the use of ultraviolet light emitting diodes (UVLEDS) for curing optical-fiber coatings. The disclosed optical-fiber resin coating apparatus includes a mold assembly in which a UV curable resin is coated onto an optical fiber. Also at the mold assembly, the coated optical fiber is exposed to UV radiation from a number of UVLEDS to cure the UV coating. A control circuit may be used to control the UV radiation output from the UVLED array. For example, the control circuit may reduce the current to one or more UVLEDS to reduce the intensity of emitted UV radiation. The control circuit may also be used to vary the intensity of the UV radiation as the optical fiber progresses through the mold assembly.

Even so, UVLEDS, though more efficient than mercury lamps, still waste a significant amount of energy in curing glass-fiber coatings. In particular, much of the emitted UV radiation is not used to cure the glass-fiber coatings.

Therefore, a need exists for a UVLED apparatus that, as compared with a conventional mercury-lamp device, not only consumes less power and generates less unwanted heat but also is capable of curing glass-fiber coatings with improved curing efficiency.

SUMMARY

Accordingly, the present invention embraces a UVLED apparatus (and associated systems and methods) for in situ curing of optical-fiber coating. The apparatus employs at least one UVLED source, such as a single UVLED or a plurality of discrete UVLEDS, that emits electromagnetic radiation into a curing space. An incompletely cured, coated glass fiber passes through the curing space, thereby absorbing electromagnetic radiation to effect curing of the optical-fiber coating.

An exemplary UVLED apparatus includes one or more UVLED sources positioned within a substantially cylindrical cavity. Each UVLED source typically has an emission pattern that defines a line of average emission L_{avg} . The cylindrical cavity has a reflective inner surface and an elliptical cross-section. Accordingly, the cavity defines a first line focus, a second line focus, and a major axis intersecting the first and second line foci. The UVLED source is typically positioned along the first line focus such that an emission angle α between the major axis and L_{avg} is between about 30 degrees and 120 degrees (e.g., between about 30 degrees and 60 degrees). A glass fiber having an incompletely cured coating is passed through the cylindrical cavity along the second line focus to effect the absorption of UV radiation emitted by the UVLED source and reflected by the reflective inner surface of the cylindrical cavity.

The foregoing illustrative summary, as well as other exemplary objectives and/or advantages of the invention, and the manner in which the same are accomplished, are

further explained within the following detailed description and its accompanying drawings.

BRIEF DESCRIPTION OF THE DRAWINGS

FIG. 1 schematically depicts a cross-sectional view of an elliptic cylinder having a reflective inner surface.

FIG. 2 schematically depicts a perspective view of an exemplary apparatus for curing a coated glass fiber.

FIG. 3 schematically depicts a cross-sectional view of an exemplary apparatus for curing a coated glass fiber.

FIG. 4 schematically depicts the relationship between UVLED emission angle and UVLED efficiency for UVLEDs of various widths.

FIG. 5 schematically depicts a cross-sectional view of another exemplary apparatus for curing a coated glass fiber.

FIG. 6a schematically depicts the emission pattern of a UVLED having an emission pattern of $\cos^{1.5}(\Phi)$.

FIG. 6b schematically depicts the emission pattern of a UVLED having an emission pattern of $\cos^2(\Phi)$.

DETAILED DESCRIPTION

In one aspect, the present invention embraces an apparatus for curing glass-fiber coatings (e.g., primary coatings, secondary coatings, and/or tertiary ink layers). The apparatus typically employs a UVLED source that is oriented at an emission angle of more than 0 degrees relative to the glass fiber.

In a particular embodiment, the apparatus for curing glass-fiber coatings includes a UVLED source, such as one or more ultraviolet light emitting diodes (UVLEDs), positioned within a cylindrical cavity (or a substantially cylindrical cavity) that has a reflective inner surface. To achieve the reflective inner surface, the cylindrical cavity may be made from stainless steel or metalized glass, such as silvered quartz, or other suitable material. In addition, the interior of the cylindrical cavity defines a curing space. In turn, the curing space defines a curing axis along which a drawn glass fiber passes during the curing process.

Typically, a protective tube surrounds the curing axis. By way of example, a transparent quartz tube (e.g., a quartz tube that is substantially transparent to UV radiation emitted by the UVLEDs) having a diameter of about 24 millimeters and a thickness of about 2 millimeters may be employed as a protective tube. In another embodiment, the protective tube (e.g., a transparent quartz tube) may have a diameter of about 10 millimeters and a thickness of about 1 millimeter. In general, it is thought that employing a smaller protective tube would improve curing efficiency (i.e., reduce UV radiation waste).

The protective tube prevents curing byproducts from damaging and/or fouling the UVLEDs within the cylindrical cavity. In this regard, volatile components of the optical-fiber coating have a tendency to evaporate during curing. In the absence of a protective tube, these curing byproducts can precipitate onto both the UVLEDs and the cavity's reflective inner surface. The protective tube can also prevent uncured coating (e.g., delivered by a coating applicator) from being inadvertently deposited within the cylindrical cavity (e.g., spilled onto the UVLEDs and/or the cavity's reflective inner surface).

An inert gas (e.g., nitrogen) or gas mixture (e.g., nitrogen and oxygen) may be introduced into the protective tube to provide an oxygen-free or a reduced-oxygen environment around an optical fiber as its coating is being cured. In this regard, it has been observed that having a small amount of

oxygen may promote efficient curing. Accordingly, the protective tube may provide an environment having between about 0.1 percent and 5 percent oxygen, such as between about 0.2 percent and 3 percent oxygen (e.g., about 0.31 percent oxygen). Providing a reduced-oxygen environment around the coated glass fiber seems to help reduce the consumption of free radicals by the oxygen.

Furthermore, the gas (e.g., nitrogen and/or oxygen) flowing through the protective tube may be heated, such as by employing one or more heat rings positioned around (i) the protective tube and/or (ii) a pipe supplying the gas. Alternatively, the gas flowing through the protective tube may be heated using infrared heaters. Heating the gas flow helps to remove unreacted coating components (e.g., coating monomers) and/or unwanted byproducts present in the cured coating.

In a typical embodiment, the cylindrical cavity has a non-circular elliptical cross-section. In other words, the cylindrical cavity usually has the shape of an elliptic cylinder. By way of illustration, an exemplary elliptic cylinder has a major axis length of 54 millimeters and a minor axis length of 45.8 millimeters. For an elliptic cylinder, the curing axis corresponds with one of the two line foci defined by the elliptic cylinder. Moreover, it is thought that the cylinder's elliptical shape can be modified to compensate for the deleterious effects that may be caused by the protective tube (e.g., refraction and reflection).

It will be appreciated by those having ordinary skill in the art that a UVLED does not emit UV radiation only toward a point or line, but rather emits UV radiation in many directions. Thus, most of the UV radiation emitted by a UVLED will not directly strike a glass-fiber coating to effect curing. In curing an optical-fiber coating, however, it is desirable that as much UV radiation as possible strike the optical fiber (i.e., a coated glass fiber). As will be understood by those having ordinary skill in the art, curing occurs when UV radiation is absorbed by photoinitiators in the glass-fiber coating.

Accordingly, the reflective surface of the cylindrical cavity can reflect otherwise misdirected UV radiation onto an optical fiber for curing, thus reducing wasted energy. Moreover, for a cylindrical cavity having an elliptical cross-section, any electromagnetic radiation that is emitted from one line focus (regardless of direction) will be directed toward the other line focus after being reflected at the inner surface of the cylinder. This principle is illustrated in FIG. 1, which schematically depicts a cross-sectional view of a reflective elliptic cylinder 15 having a first line focus 11 and a second line focus 12. As depicted in FIG. 1, each UV ray 13 emitted from the first line focus 11 will intersect the second line focus 12.

Accordingly, in one embodiment, each UVLED source may be positioned along the other line focus (i.e., the line focus that does not correspond with a curing axis) such that each UVLED source emits UV radiation in the general direction of the curing axis. In this regard, FIGS. 2 and 3 depict an exemplary apparatus 20 for curing a coated glass fiber 26. The apparatus 20 includes a substantially cylindrical cavity 25 having an elliptical shape and a reflective inner surface. The cavity 25 defines a first line focus 21 and a second line focus 22. One or more UVLED sources 24 are positioned along the first line focus 21. Typically, each UVLED source 24 is formed from a single light emitting diode. That said, it is within the scope of the present invention to employ an array of small light emitting diodes to form each UVLED source 24.

In one embodiment, the apparatus 20 may include a plurality of UVLED sources 24 positioned contiguously to one another along the first line focus 21 (i.e., directly stacked). In another embodiment, adjacent UVLED sources may be vertically separated by a space of at least about 5 millimeters (e.g., at least about 10 millimeters). The second line focus 22 further defines a curing axis along which a coated glass fiber 26 passes so it can be cured. As depicted in FIG. 3, UV rays 23 emitted from the UVLED source 24 may reflect off the inner surface of the cavity 25 such that the reflected UV rays 23 are incident to the coated glass fiber 26.

To facilitate uniform curing of the coated glass fiber 26, some of the UVLED sources 24 may be differently oriented. The apparatus 20 typically includes a single UVLED positioned within a particular horizontal plane. In an alternative embodiment, multiple UVLEDs may be positioned (e.g., at a point other than the first focal line) within a horizontal plane to promote more uniform curing of the glass fiber.

In another embodiment, a system for curing a coated glass fiber may include a plurality of differently oriented cavity segments (e.g., apparatuses for curing a coated glass fiber). Each cavity may have a common curing axis (e.g., the second focal line), but a different first line focus.

As depicted in FIG. 2, a second apparatus 30 for curing a glass fiber may have a different orientation than the first apparatus 20 (e.g., the second apparatus 30 may have UVLED sources positioned along a line focus 31 that differs from the first line focus 21). As further illustrated in FIG. 2, the second apparatus 30 is rotated 180 degrees relative to the orientation of the first apparatus 20. That said, various degrees of rotation may separate adjacent cavity segments (i.e., adjacent apparatuses). By way of non-limiting illustration, a 45-degree rotation, a 90-degree rotation, or a 135-degree rotation may separate adjacent cavity segments while maintaining the common curing axis.

In this regard, the positioning of a plurality of cavity segments in a three-dimensional arrangement may be defined by the cylindrical coordinate system (i.e., r, θ , z). Using the cylindrical coordinate system and as described herein, the curing axis defines a z-axis. Furthermore, as herein described and as will be understood by those having ordinary skill in the art, the variable r is the perpendicular distance of a point to the z-axis. The variable θ describes the angle in a plane that is perpendicular to the z-axis. In other words and by reference to a Cartesian coordinate system (i.e., defining an x-axis, a y-axis, and a z-axis), the variable θ describes the angle between a reference axis (e.g., the x-axis) and the orthogonal projection of a point onto the x-y plane. Finally, the z variable describes the height or position of a reference point along the z-axis.

Thus, a point is defined by its cylindrical coordinates (r, θ , z). For cavity segments employed in exemplary configurations, the variable r is usually constant and may refer to the distance between the first line focus of a cavity segment and the curing axis (e.g., where the respective cavity segments employ the same elliptical dimensions). Accordingly, to the extent the variable r is largely fixed, the position of the cavity segments can be described by their respective z and θ coordinates.

By way of non-limiting example, a plurality of cavity segments having the same elliptical dimensions may be positioned in a helical arrangement with the first cavity segment at the position (1, 0, 0), where r is fixed at a constant distance (i.e., represented here as a unitless 1). Additional cavity segments may be positioned, for example, every 90 degrees (i.e., $\pi/2$) with a Δz of 1 (i.e., a positional step change represented here as a unitless 1). Thus, a second

cavity segment would have the coordinates (1, $\pi/2$, 1), a third cavity segment would have the coordinates (1, π , 2), and a fourth cavity segment would have the coordinates (1, $3\pi/2$, 3), thereby defining a helical configuration. In other words, the respective cavity segments are rotated around the curing axis.

That said, the respective distances r and z need not be equivalent. Moreover, the several cavity segments in an arrangement as herein disclosed need not be offset by 90 degrees (e.g., $\pi/2$, π , $3\pi/2$, etc.). For example, the respective cavity segments may be offset by 60 degrees (e.g., $\pi/3$, $2\pi/3$, π , etc.) or by 120 degrees (e.g., $2\pi/3$, $4\pi/3$, 2π , etc.). Indeed, the cavity segments in an arrangement as discussed herein need not follow a regularized helical rotation.

* * *

Applicant has discovered that the protective tube interferes with the UV radiation directed toward the curing axis.

By way of example, Applicant simulated directing a 0.1-millimeter wide UVLED having an emission pattern of $\cos^{1.5}(\Phi)$ directly toward (i.e., employing an emission angle of 0 degrees) a target having a diameter of 250 microns, the approximate diameter of a representative optical fiber. As used herein, the size of a UVLED refers to its actual size or, if the UVLED is rescaled with a lens, its effective size. The simulation positioned the UVLED source and the target at opposite foci within a reflective elliptic cylinder having a major axis length of 54 millimeters and a minor axis length of 45.8 millimeters. In the absence of a protective tube, nearly 100 percent of the UV rays hit the target.

When a protective tube having a diameter of 24 millimeters and a refractive index of 1.5 is employed, however, only about 75 percent of the UV rays hit the 250-micron target. In this regard, UV rays having an incidence angle other than approximately 90 degrees with the protective tube can be undesirably refracted or reflected.

Applicant also simulated directing the UVLED toward a 250-micron target surrounded by a protective tube while employing an emission angle of 90 degrees rather than 0 degrees. Table 1 (below) shows UVLED efficiency (i.e., the percent of UV radiation hitting a 250-micron target) at respective emission angles of 0 degrees and 90 degrees for UVLEDs of various widths.

TABLE 1

(UVLED Efficiency)		
UVLED Width (mm)	UVLED Efficiency (0° emission angle)	UVLED Efficiency (90° emission angle)
0.1	77	100
0.2	77	79
0.3	77	61
0.4	77	50
0.5	76	43
1	45	25
1.5	31	17
2	24	13
2.5	19	11

Table 2 (below) shows UVLED efficiency for a UVLED having a width (or effective width) of 0.1 mm.

TABLE 2

(UVLED Efficiency)					
Elliptic Cylinder Major Axis Width (mm)	Elliptic Cylinder Minor Axis Width (mm)	Protective Tube Diameter (mm)	Emission Pattern	Emission Angle (degrees)	UVLED Effi- ciency (per- centage)
54	45.8	—	$\cos^2(\Phi)$	0	100
54	45.8	24	$\cos^2(\Phi)$	0	75
54	45.8	24	$\cos^{1.5}(\Phi)$	0	77
54	45.8	24	$\cos^{1.5}(\Phi)$	90	100
60	51.8	24	$\cos^{1.5}(\Phi)$	0	78
60	51.8	24	$\cos^{1.5}(\Phi)$	90	100

Applicant further simulated UVLED efficiency for various emission angles using various UVLEDs, where (i) the reflective elliptic cylinder had a major axis length of 54 millimeters and a minor axis length of 45.8 millimeters, (ii) the protective tube had a diameter of 24 millimeters, and (iii) the UVLED had an emission pattern of $\cos^{1.5}(\Phi)$. For this apparatus configuration, FIG. 4 graphically depicts the relationship between UVLED emission angle and UVLED efficiency for UVLEDs of various widths. In brief, FIG. 4 shows that for a UVLED having a width of less than 0.5 millimeter, employing an emission angle of more than 0 degrees improves UVLED efficiency.

For UVLEDs having a width (or effective width) of less than about 0.5 millimeter (as deployed in the foregoing apparatus configuration), emission angle α can be optimally calculated in accordance with the following equation:

$$\alpha = 733.33x^2 - 690x + 161.67, \text{ where}$$

x is the width of the UVLED,

$x < 0.5$ millimeter, and

the UVLED has an emission pattern of $\cos^{1.5}(\Phi)$.

Moreover, for the foregoing apparatus configuration, the UVLED efficiency can be optimally calculated in accordance with the following equation:

$$\text{UVLED efficiency} = 1001.3x^3 + 1166.1x^2 - 461.6x + 140.45, \text{ where}$$

x is the width of the UVLED,

$x < 0.5$ millimeter, and

the UVLED has an emission pattern of $\cos^{1.5}(\Phi)$.

For a point source, the optimum emission angle α typically has a minimum value α_{min} and a maximum value α_{max} according to the following equations:

$$\alpha_{min} = \theta_{source} / 2 + \arctan(r_{tube} / (2f)), \text{ and}$$

$$\alpha_{max} = 2\pi - \alpha_{min},$$

where

r_{tube} is the radius of the protective tube,

f is the distance from the central axis of the elliptic cylinder to a line focus (i.e., $2f$ is the distance between the line foci), and

θ_{source} is the angle of the emittance cone of the point source that contains 95 percent of the emitted power from the point source.

As noted, the emittance cone of the point source contains 95 percent of the emitted power from the point source. Therefore, 95 percent of the emitted power from the point source is emitted within the cone defined by the equation $\alpha + k \cdot \theta_{source}$, where $-0.5 \leq k \leq 0.5$.

By way of a non-limiting example, if $\theta_{source} = 154$ degrees, $f = 28$ millimeters, and $r_{tube} = 12$ millimeters, then $\alpha_{min} = 89$ degrees and $\alpha_{max} = 271$ degrees.

Those having ordinary skill will appreciate that the UV radiation emitted from a UVLED source is not emitted from a single point. That said, the foregoing equation for calculating the optimum emission angle of a point source is a useful tool for approximating the optimum emission angle of small UVLED sources, such as UVLED sources with a width of 0.2 millimeter or less (e.g., 0.1 millimeter or less).

More generally and in accordance with the present invention, the optimum emission angle is typically at least about 30 degrees, such as between 30 degrees and 100 degrees (e.g., about 90 degrees for a UVLED having a width of about 0.3 millimeter or less), more typically between about 30 degrees and 60 degrees (e.g., about 45 degrees for a UVLED having a width of about 0.22 millimeter), between each UVLED source and the major axis of the elliptical cylinder. In this regard, ever smaller UVLEDs may facilitate the deployment of a curing apparatus that can efficiently employ emission angles approaching 180 degrees. By way of example, such a curing apparatus might employ emission angles greater than about 100 degrees, such as between about 120 degrees and 150 degrees (e.g., about 135 degrees). When a protective tube is present within the elliptical cylinder (i.e., surrounding the curing axis), employing an angled UVLED source in this way will provide improved UV absorption during curing.

FIG. 5 depicts an exemplary apparatus 50 for curing a coated glass fiber 26 in accordance with the present invention. In particular, the apparatus 50 employs one or more angled UVLED sources 24 positioned within a substantially cylindrical cavity 25 having an elliptical shape and a reflective inner surface. The cavity 25 defines a first line focus 21 and a second line focus 22. The second line focus 22 defines a curing axis. A coated glass fiber 26 passes along the curing axis during curing. Finally, a protective tube 35 surrounds the curing axis and the coated glass fiber 26.

The cavity 25 also defines a major axis 34 that intersects the first line focus 21 and the second line focus 22. One or more UVLED sources 24 are positioned along the first line focus 21. Each UVLED source 24 emits UV rays 23 in a distinctive emission pattern. In general, an emission pattern has a line of average emission L_{avg} 23a (i.e., an average of all the UV rays emitted by the UVLED source 24).

In an exemplary embodiment, an UVLED source 24 is angled away from the coated glass fiber 26. In particular, the UVLED source 24 is positioned so that an emission angle α is defined between the line of average emission L_{avg} 23a and the elliptical cylinder's major axis 34. The emission angle α is typically between about 30 degrees and 100 degrees (e.g., between 30 degrees and 60 degrees), more typically between about 40 degrees and 50 degrees (e.g., 45 degrees).

Although the emission angle α is typically calculated relative to the line of average emission L_{avg} for a UVLED source (e.g., a single UVLED), it is within the scope of the invention to describe the emission angle α relative to a line defined by a UVLED source's median or mode (i.e., a line of maximum emission L_{max}).

Typically, each UVLED source within the cavity is oriented to have the same emission angle. That said, it is within the scope of the present invention to orient UVLED sources within the cavity such that the UVLED sources have different emission angles.

Those having ordinary skill in the art will appreciate that the UV radiation emitted from a UVLED is not emitted from a single point. Therefore, and because of the small size of a coated glass fiber (e.g., a 250-micron diameter), it is desirable to use small UVLED sources (e.g., a 3-millimeter square UVLED or a 1-millimeter square UVLED). In gen-

eral, a greater percentage of reflected UV radiation will be incident to the coated glass fiber using a small UVLED as compared with using a larger UVLED.

Moreover, each UVLED source may include a lens (e.g., a convex lens, such as a biconvex or plano-convex lens) for focusing emitted UV radiation. In particular, each lens may have a focus at one of the two line foci (e.g., the line focus not defining a curing axis). For example, a cylindrical lens with a high numerical aperture can be used to rescale a 3-millimeter square UVLED so that it has an effective width of about 0.4 millimeter or less at the line focus. By including a lens with each UVLED, the efficiency of the apparatus may be further enhanced.

In an alternative embodiment, the apparatus for curing a coated glass fiber may employ one or more optical fibers (e.g., one or more multimode optical fibers) to transmit UV radiation. In this regard, these optical fibers are typically positioned along the first line focus of the apparatus as an alternative to positioning UVLEDs along the first line focus. Typically, each optical fiber is coupled to one or more sources of UV radiation, such as a UVLED. By way of example, a plurality of small UVLEDs may be coupled to a plurality of optical fibers in a one-to-one relationship (e.g., 20 UVLEDs and 20 optical fibers). Thereupon, the optical fibers may be configured in various arrays at or near the first line focus.

Moreover, at least one—and typically each—optical fiber is oriented at the first line focus to provide an emission angle of between about 30 degrees and 120 degrees (e.g., between 45 degrees and 90 degrees). Such optical fibers typically employ a central glass fiber, but may alternatively employ a central plastic fiber.

Moreover, the use of an optical fiber to transmit UV radiation into the cavity may facilitate the deployment of a curing apparatus that can efficiently employ emission angles approaching 180 degrees. By way of example, such a curing apparatus might employ emission angles between 120 degrees and 180 degrees (e.g., about 150 degrees).

To simplify coupling with the UVLED source(s), multimode optical fibers are typically employed for purposes of UV-radiation transmission. That said, it is within the scope of the present invention to employ single-mode optical fibers (e.g., holey glass fibers). An exemplary single-mode optical fiber is a large-mode-area fiber (LMA) that provides a Gaussian beam having a diameter of 0.1 millimeter or less. An exemplary holey optical fiber is disclosed in commonly assigned U.S. Patent Application Publication No. 2010/0189397 for a Single-Mode Optical Fiber (Richard et al.), which is hereby incorporated by reference in its entirety.

To supplement the foregoing disclosure, this application incorporates entirely herein by reference commonly assigned U.S. Patent Application Publication No. US2010/0183821 A1 for a UVLED Apparatus for Curing Glass-Fiber Coatings (Hartsuiker et al.); commonly assigned U.S. Patent Application No. 61/351,205 for a Curing Apparatus Having UV Sources That Emit Differing Ranges of UV Radiation, filed Jun. 3, 2010, (Gharbi et al.); and commonly assigned U.S. Patent Application No. 61/372,312 for a Method and Apparatus Providing Increased UVLED Intensity, filed Aug. 10, 2010, (Overton). This application further incorporates entirely herein by reference U.S. Pat. Nos. 4,683,525; 4,710,638; 7,399,982; and 7,498,065.

* * *

UVLEDs are capable of emitting wavelengths within a much smaller spectrum than conventional UV lamps. This

promotes the use of more of the emitted electromagnetic radiation for curing. That said, the UVLED apparatus (and its related system and method) disclosed herein may be modified to employ mercury lamps and/or fusion lamps as radiation sources (e.g., a supplemental source of UV radiation if insufficient curing is achieved using only UVLEDs).

In this regard, a UVLED source for use in the present invention may be any suitable UVLED that emits electromagnetic radiation having wavelengths of between about 200 nanometers and 600 nanometers. By way of example, the UVLED may emit electromagnetic radiation having wavelengths of between about 200 nanometers and 450 nanometers (e.g., between about 250 nanometers and 400 nanometers). In a particular exemplary embodiment, the UVLED may emit electromagnetic radiation having wavelengths of between about 300 nanometers and 400 nanometers. In another particular exemplary embodiment, the UVLED may emit electromagnetic radiation having wavelengths of between about 350 nanometers and 425 nanometers.

As noted, a UVLED typically emits a narrow band of electromagnetic radiation. For example, the UVLED may substantially emit electromagnetic radiation having wavelengths that vary by no more than about 30 nanometers, typically no more than about 20 nanometers (e.g., a UVLED emitting a narrow band of UV radiation mostly between about 375 nanometers and 395 nanometers). It has been observed that a UVLED emitting a narrow band of UV radiation mostly between about 395 nanometers and 415 nanometers is more efficient than other narrow bands of UV radiation.

Moreover, it has been observed that in some cases UVLEDs emitting UV radiation slightly above the wavelength at which a glass-fiber coating has maximum absorption (e.g., an absorption peak of about 360 nanometers) promote more efficient polymerization than do UVLEDs emitting UV radiation at the wavelength at which the glass-fiber coating has maximum absorption. Accordingly, the UVLED apparatus may employ UVLEDs that have a mean output wavelength at least about 10 nanometers greater than the glass-fiber coating's targeted absorption peak (e.g., at least about 10 to 15 nanometers greater than a targeted absorption peak). That said, it is within the scope of the present invention to employ UVLEDs that have a mean output wavelength within about 10 nanometers (e.g., within about 5 nanometers) of a targeted absorption peak.

In this regard, although an exemplary UVLED source emits substantially all of its electromagnetic radiation within a defined range (e.g., between 350 nanometers and 450 nanometers, such as between 370 nanometers and 400 nanometers), the UVLED source may emit small amounts of electromagnetic radiation outside the defined range. In this regard, 80 percent or more (e.g., at least about 90 percent) of the output (i.e., emitted electromagnetic radiation) of an exemplary UVLED source is typically within a defined range (e.g., between about 375 nanometers and 425 nanometers).

As noted, UVLEDs can have various emission patterns (e.g., a far field pattern). By way of example, a UVLED employed in accordance with the present invention may have a substantially Lambertian emission pattern. In other embodiments, a UVLED source (e.g., a UVLED) may have a Gaussian or multimodal emission pattern. Another exemplary UVLED may have an emission pattern of $\cos^{1.5}(\Phi)$ or $\cos^2(\Phi)$. FIG. 6a schematically depicts the emission pattern of a UVLED having an emission pattern of $\cos^{1.5}(\Phi)$. FIG.

11

6b schematically depicts the emission pattern of a UVLED having an emission pattern of $\cos^2(\Phi)$.

UVLEDs are typically much smaller than conventional UV lamps (e.g., mercury bulbs). By way of example, the UVLED may be a 0.25-inch square UVLED. The UVLED may be affixed to a platform (e.g., a 1-inch square or larger mounting plate). Of course, other UVLED shapes and sizes are within the scope of the present invention. By way of example, a 3-millimeter square UVLED may be employed in the apparatus according to the present invention.

Each UVLED may have a power output of as much as 32 watts (e.g., a UVLED having a power input of about 160 watts and a power output of about 32 watts). That said, UVLEDs having outputs greater than 32 watts (e.g., 64 watts) may be employed as such technology becomes available. Using UVLEDs with higher power output may be useful for increasing the rate at which optical-fiber coatings cure, thus promoting increased production line speeds.

Each UVLED source may be positioned at a distance of between about 1 millimeter and 100 millimeters (e.g., typically between about 5 millimeters and 30 millimeters) from the optical fiber to be cured (e.g., from the curing axis). More typically, each UVLED source is positioned at a distance of about 25 millimeters from the optical fiber to be cured.

It will be further appreciated by those having ordinary skill in the art that UVLEDs may absorb incident electromagnetic radiation, which might diminish the quantity of reflected UV radiation available for absorption by the glass-fiber coating. Moreover, incident UV radiation can damage a UVLED. Therefore, in an apparatus for curing glass-fiber coatings having a plurality of UVLEDs, it may be desirable to position the UVLEDs in a way that reduces UV radiation incident to the UVLEDs. Accordingly, a vertical space of at least about 10 millimeters may separate adjacent UVLEDs. Moreover, the UVLEDs may employ a reflective surface (e.g., a surface coating) that promotes reflection of incident electromagnetic radiation yet permits the transmission of emitted electromagnetic radiation.

It may be desirable for the power of the UV radiation incident to the optical fiber to vary as the optical fiber progresses through the apparatus. Varying the power of the UV radiation may enhance the curing of the glass-fiber coating. Depending on the curing properties of a particular coating, it may be desirable to initially expose the optical fiber to high intensity UV radiation. Alternatively, it may be desirable to initially expose the optical fiber to lower intensity UV radiation (e.g., between about 10 percent and 50 percent of the maximum exposure intensity) before exposing the optical fiber to high intensity UV radiation (e.g., the maximum intensity to which the optical fiber is exposed). In this regard, initially exposing the optical fiber to lower intensity UV radiation may be useful in controlling the generation of free radicals in an uncured coating. Those having ordinary skill in the art will appreciate that if too many free radicals are present, many of the free radicals may recombine rather than encourage the polymerization of the glass-fiber coating—an undesirable effect. Accordingly, in an apparatus containing a plurality of UVLED sources, the intensity of the UV radiation output from the UVLED sources may vary.

In this regard, an apparatus as described herein may include a dark space between one or more UVLED sources. In other words, the apparatus may include a space in which substantially no UV radiation is incident to the optical fiber being cured. A pause in the curing process provided by a dark space can help to ensure even and efficient curing of the

12

optical-fiber coatings. In particular, a dark space may be useful in preventing too many free radicals from being present in a glass-fiber coating before it is cured (i.e., dark space helps to control free-radical generation).

For example, it may be desirable to initially expose an optical fiber to low power UV radiation and then pass the optical fiber through a dark space. After the optical fiber passes through a dark space, it is exposed to higher power UV radiation to complete the curing process. A curing apparatus employing dark space is disclosed in commonly assigned U.S. Pat. No. 7,322,122 for a Method and Apparatus for Curing a Fiber Having at Least Two Fiber Coating Curing Stages, which is hereby incorporated by reference in its entirety.

Moreover, an apparatus for curing glass-fiber coatings may include a control circuit for controlling the UV radiation output from the UVLED sources. The control circuit may be used to vary the intensity of the UV radiation as an optical fiber progresses through the apparatus.

Alternatively, to ensure that the optical fiber receives a consistent dose of ultraviolet radiation, the UV radiation output of the UVLED sources may vary with the speed at which the optical fiber passes through the apparatus. That is to say, at higher speeds (i.e., the speed the optical fiber passes through the apparatus), the output intensity of the UVLED sources may be greater than the output intensity at lower speeds. The output intensity of the UVLED sources may be controlled by reducing (or increasing) the current flowing to the UVLEDs.

Finally, glass fiber is typically rotated or otherwise subjected to perturbations during drawing operations to reduce unwanted dispersion effects. It is thought that this may further enhance the curing process as herein described.

* * *

The foregoing description embraces the curing of one or more coating layers on a glass fiber. The disclosed apparatus, system, and method may be similarly employed to cure a buffer layer onto an optical fiber or a ribbon matrix around a plurality of optical fibers.

* * *

Relative to other UV radiation sources, UVLED devices typically generate a smaller amount of heat energy. That said, to dissipate the heat energy created by a UVLED, a heat sink may be located behind the UVLED (e.g., opposite the portion of the UVLED that emits UV radiation). The heat sink may be one-inch square, although other heat sink shapes and sizes are within the scope of the present invention.

The heat sink may be formed of a material suitable for conducting heat (e.g., brass, aluminum, or copper). The heat sink may include a heat exchanger that employs a liquid coolant (e.g., chilled water), which circulates within the heat exchanger to draw heat from the UVLED.

Removing heat generated by the UVLED is important for several reasons. First, excess heat may slow the rate at which optical-fiber coatings cure. Furthermore, excess heat can cause the temperature of the UVLED to rise, which can reduce UV-radiation output. Indeed, continuous high-temperature exposure can permanently reduce the UVLED's radiation output. With adequate heat removal, however, the UVLED may have a useful life of 50,000 hours or more.

* * *

In accordance with the foregoing, the resulting optical fiber includes one or more coating layers (e.g., a primary

coating and a secondary coating). At least one of the coating layers—typically the secondary coating—may be colored and/or possess other markings to help identify individual fibers. Alternatively, a tertiary ink layer may surround the primary and secondary coatings.

For example, the resulting optical fiber may have one or more coatings (e.g., the primary coating) that comprise a UV-curable, urethane acrylate composition. In this regard, the primary coating may include between about 40 and 80 weight percent of polyether-urethane acrylate oligomer as well as photoinitiator, such as LUCIRIN® TPO, which is commercially available from BASF. In addition, the primary coating typically includes one or more oligomers and one or more monomer diluents (e.g., isobornyl acrylate), which may be included, for instance, to reduce viscosity and thereby promote processing. Exemplary compositions for the primary coating include UV-curable urethane acrylate products provided by DSM Desotech (Elgin, Ill.) under various trade names, such as DeSolite® DP 1011, DeSolite® DP 1014, DeSolite® DP 1014XS, and DeSolite® DP 1016. An exemplary coating system is available from Draka Comteq under the trade name ColorLock®^{XSS}.

Those having ordinary skill in the art will recognize that an optical fiber with a primary coating (and an optional secondary coating and/or ink layer) typically has an outer diameter of between about 235 microns and about 265 microns (μm). The component glass fiber itself (i.e., the glass core and surrounding cladding layers) typically has a diameter of about 125 microns, such that the total coating thickness is typically between about 55 microns and 70 microns.

With respect to an exemplary optical fiber achieved according to the present curing method, the component glass fiber may have an outer diameter of about 125 microns. With respect to the optical fiber's surrounding coating layers, the primary coating may have an outer diameter of between about 175 microns and about 195 microns (i.e., a primary coating thickness of between about 25 microns and 35 microns) and the secondary coating may have an outer diameter of between about 235 microns and about 265 microns (i.e., a secondary coating thickness of between about 20 microns and 45 microns). Optionally, the optical fiber may include an outermost ink layer, which is typically between two and ten microns thick.

In an alternative embodiment, the resulting optical fiber may possess a reduced diameter (e.g., an outermost diameter between about 150 microns and 230 microns). In this alternative optical-fiber configuration, the thickness of the primary coating and/or secondary coating is reduced, while the diameter of the component glass fiber is maintained at about 125 microns. By way of example, in such embodiments, the primary coating layer may have an outer diameter of between about 135 microns and about 175 microns (e.g., about 160 microns), and the secondary coating layer may have an outer diameter of between about 150 microns and about 230 microns (e.g., more than about 165 microns, such as 190-210 microns or so). In other words, the total diameter of the optical fiber is reduced to less than about 230 microns (e.g., about 200 microns).

Exemplary coating formulations for use with the apparatus and method described herein are disclosed in the following commonly assigned applications, each of which is incorporated by reference in its entirety: U.S. Patent Application No. 61/112,595 for a Microbend-Resistant Optical Fiber, filed Nov. 7, 2008, (Overton); International Patent Application Publication No. WO 2009/062131 A1 for a Microbend-Resistant Optical Fiber, (Overton); U.S. Patent

Application Publication No. US2009/0175583 A1 for a Microbend-Resistant Optical Fiber, (Overton); and U.S. Patent Application Publication No. US20100119202 A1 for a Reduced-Diameter Optical Fiber (Overton).

5 To supplement the present disclosure, this application incorporates entirely by reference the following commonly assigned patents, patent application publications, and patent applications: U.S. Pat. No. 4,838,643 for a Single Mode Bend Insensitive Fiber for Use in Fiber Optic Guidance Applications (Hodges et al.); U.S. Pat. No. 7,623,747 for a Single Mode Optical Fiber (de Montmorillon et al.); U.S. Pat. No. 7,587,111 for a Single-Mode Optical Fiber (de Montmorillon et al.); U.S. Pat. No. 7,356,234 for a Chromatic Dispersion Compensating Fiber (de Montmorillon et al.); U.S. Pat. No. 7,483,613 for a Chromatic Dispersion Compensating Fiber (Bigot-Astruc et al.); U.S. Pat. No. 7,526,177 for a Fluorine-Doped Optical Fiber (Matthijssse et al.); U.S. Pat. No. 7,555,186 for an Optical Fiber (Flammer et al.); U.S. Patent Application Publication No. US2009/0252469 A1 for a Dispersion-Shifted Optical Fiber (Sillard et al.); U.S. Patent Application Publication No. US2011/0044595 A1 for a Transmission Optical Fiber Having Large Effective Area (Sillard et al.); International Patent Application Publication No. WO 2009/062131 A1 for a Microbend-Resistant Optical Fiber, (Overton); U.S. Patent Application Publication No. US2009/0175583 A1 for a Microbend-Resistant Optical Fiber, (Overton); U.S. Patent Application Publication No. US2009/0279835 A1 for a Single-Mode Optical Fiber Having Reduced Bending Losses, filed May 6, 2009, (de Montmorillon et al.); U.S. Pat. No. 7,889,960 for a Bend-Insensitive Single-Mode Optical Fiber, (de Montmorillon et al.); U.S. Patent Application Publication No. US2010/0021170 A1 for a Wavelength Multiplexed Optical System with Multimode Optical Fibers, filed Jun. 23, 2009, (Lumineau et al.); U.S. Patent Application Publication No. US2010/0028020 A1 for a Multimode Optical Fibers, filed Jul. 7, 2009, (Gholami et al.); U.S. Patent Application Publication No. US2010/0119202 A1 for a Reduced-Diameter Optical Fiber, filed Nov. 6, 2009, (Overton); U.S. Patent Application Publication No. US2010/0142969 A1 for a Multimode Optical System, filed Nov. 6, 2009, (Gholami et al.); U.S. Patent Application Publication No. US2010/0118388 A1 for an Amplifying Optical Fiber and Method of Manufacturing, filed Nov. 12, 2009, (Pastouret et al.); U.S. Patent Application Publication No. US2010/0135627 A1 for an Amplifying Optical Fiber and Production Method, filed Dec. 2, 2009, (Pastouret et al.); U.S. Patent Application Publication No. US2010/0142033 for an Ionizing Radiation-Resistant Optical Fiber Amplifier, filed Dec. 8, 2009, (Regnier et al.); U.S. Patent Application Publication No. US2010/0150505 A1 for a Buffered Optical Fiber, filed Dec. 11, 2009, (Testu et al.); U.S. Patent Application Publication No. US2010/0171945 for a Method of Classifying a Graded-Index Multimode Optical Fiber, filed Jan. 7, 2010, (Gholami et al.); U.S. Patent Application Publication No. US2010/0189397 A1 for a Single-Mode Optical Fiber, filed Jan. 22, 2010, (Richard et al.); U.S. Patent Application Publication No. US2010/0189399 A1 for a Single-Mode Optical Fiber Having an Enlarged Effective Area, filed Jan. 27, 2010, (Sillard et al.); U.S. Patent Application Publication No. US2010/0189400 A1 for a Single-Mode Optical Fiber, filed Jan. 27, 2010, (Sillard et al.); U.S. Patent Application Publication No. US2010/0214649 A1 for an Optical Fiber Amplifier Having Nanostructures, filed Feb. 19, 2010, (Burrow et al.); U.S. Patent Application Publication No. US2010/0254653 A1 for a Multimode Fiber, filed Apr. 22, 2010, (Molin et al.); U.S. Patent Application Publication No.

US2010/0310218 A1 for a Large Bandwidth Multimode Optical Fiber Having a Reduced Cladding Effect, filed Jun. 4, 2010, (Molin et al.); U.S. Patent Application Publication No. US2011/0058781 A1 for a Multimode Optical Fiber Having Improved Bending Losses, filed Sep. 9, 2010, (Molin et al.); U.S. Patent Application Publication No. US2011/0064367 A1 for a Multimode Optical Fiber, filed Sep. 17, 2010, (Molin et al.); U.S. Patent Application Publication No. US2011/0069724 A1 for an Optical Fiber for Sum-Frequency Generation, filed Sep. 22, 2010, (Richard et al.); U.S. patent application Ser. No. 12/944,422 for a Rare-Earth-Doped Optical Fiber Having Small Numerical Aperture, filed Nov. 11, 2010, (Boivin et al.); U.S. patent application Ser. No. 12/953,948 for a High-Bandwidth, Multimode Optical Fiber with Reduced Cladding Effect, filed Nov. 24, 2010, (Molin et al.); U.S. patent application Ser. No. 12/954,036 for a High-Bandwidth, Dual-Trench-Assisted Multimode Optical Fiber, filed Nov. 24, 2010, (Molin et al.); U.S. patent application Ser. No. 12/959,688 for a Multimode Optical Fiber with Low Bending Losses and Reduced Cladding Effect, filed Dec. 3, 2010, (Molin et al.); U.S. patent application Ser. No. 12/959,866 for a High-Bandwidth Multimode Optical Fiber Having Reduced Bending Losses, filed Dec. 3, 2010, (Molin et al.); U.S. patent application Ser. No. 13/017,089 for a Non-Zero Dispersion Shifted Optical Fiber Having a Large Effective Area, filed Jan. 31, 2011, (Sillard et al.); U.S. patent application Ser. No. 13/017,092 for a Non-Zero Dispersion Shifted Optical Fiber Having a Short Cutoff Wavelength, filed Jan. 31, 2011, (Sillard et al.); U.S. patent application Ser. No. 13/037,943 for a Broad-Bandwidth Multimode Optical Fiber Having Reduced Bending Losses, filed Mar. 1, 2011, (Bigot-Astruc et al.); and U.S. patent application Ser. No. 13/048,028 for a Single-Mode Optical Fiber, filed Mar. 15, 2011, (de Montmorillon et al.).

To supplement the present disclosure, this application further incorporates entirely by reference the following commonly assigned patents, patent application publications, and patent applications: U.S. Pat. No. 5,574,816 for Polypropylene-Polyethylene Copolymer Buffer Tubes for Optical Fiber Cables and Method for Making the Same; U.S. Pat. No. 5,717,805 for Stress Concentrations in an Optical Fiber Ribbon to Facilitate Separation of Ribbon Matrix Material; U.S. Pat. No. 5,761,362 for Polypropylene-Polyethylene Copolymer Buffer Tubes for Optical Fiber Cables and Method for Making the Same; U.S. Pat. No. 5,911,023 for Polyolefin Materials Suitable for Optical Fiber Cable Components; U.S. Pat. No. 5,982,968 for Stress Concentrations in an Optical Fiber Ribbon to Facilitate Separation of Ribbon Matrix Material; U.S. Pat. No. 6,035,087 for an Optical Unit for Fiber Optic Cables; U.S. Pat. No. 6,066,397 for Polypropylene Filler Rods for Optical Fiber Communications Cables; U.S. Pat. No. 6,175,677 for an Optical Fiber Multi-Ribbon and Method for Making the Same; U.S. Pat. No. 6,085,009 for Water Blocking Gels Compatible with Polyolefin Optical Fiber Cable Buffer Tubes and Cables Made Therewith; U.S. Pat. No. 6,215,931 for Flexible Thermoplastic Polyolefin Elastomers for Buffering Transmission Elements in a Telecommunications Cable; U.S. Pat. No. 6,134,363 for a Method for Accessing Optical Fibers in the Midspan Region of an Optical Fiber Cable; U.S. Pat. No. 6,381,390 for a Color-Coded Optical Fiber Ribbon and Die for Making the Same; U.S. Pat. No. 6,181,857 for a Method for Accessing Optical Fibers Contained in a Sheath; U.S. Pat. No. 6,314,224 for a Thick-Walled Cable Jacket with Non-Circular Cavity Cross Section; U.S. Pat. No. 6,334,016 for an Optical Fiber Ribbon Matrix Material Having Optimal Handling Characteristics; U.S. Pat. No. 6,321,012 for an

Optical Fiber Having Water Swellable Material for Identifying Grouping of Fiber Groups; U.S. Pat. No. 6,321,014 for a Method for Manufacturing Optical Fiber Ribbon; U.S. Pat. No. 6,210,802 for Polypropylene Filler Rods for Optical Fiber Communications Cables; U.S. Pat. No. 6,493,491 for an Optical Drop Cable for Aerial Installation; U.S. Pat. No. 7,346,244 for a Coated Central Strength Member for Fiber Optic Cables with Reduced Shrinkage; U.S. Pat. No. 6,658,184 for a Protective Skin for Optical Fibers; U.S. Pat. No. 6,603,908 for a Buffer Tube that Results in Easy Access to and Low Attenuation of Fibers Disposed Within Buffer Tube; U.S. Pat. No. 7,045,010 for an Applicator for High-Speed Gel Buffering of Flextube Optical Fiber Bundles; U.S. Pat. No. 6,749,446 for an Optical Fiber Cable with Cushion Members Protecting Optical Fiber Ribbon Stack; U.S. Pat. No. 6,922,515 for a Method and Apparatus to Reduce Variation of Excess Fiber Length in Buffer Tubes of Fiber Optic Cables; U.S. Pat. No. 6,618,538 for a Method and Apparatus to Reduce Variation of Excess Fiber Length in Buffer Tubes of Fiber Optic Cables; U.S. Pat. No. 7,322,122 for a Method and Apparatus for Curing a Fiber Having at Least Two Fiber Coating Curing Stages; U.S. Pat. No. 6,912,347 for an Optimized Fiber Optic Cable Suitable for Microduct Blown Installation; U.S. Pat. No. 6,941,049 for a Fiber Optic Cable Having No Rigid Strength Members and a Reduced Coefficient of Thermal Expansion; U.S. Pat. No. 7,162,128 for Use of Buffer Tube Coupling Coil to Prevent Fiber Retraction; U.S. Pat. No. 7,515,795 for a Water-Swellable Tape, Adhesive-Backed for Coupling When Used Inside a Buffer Tube (Overton et al.); U.S. Patent Application Publication No. 2008/0292262 for a Grease-Free Buffer Optical Fiber Buffer Tube Construction Utilizing a Water-Swellable, Texturized Yarn (Overton et al.); European Patent Application Publication No. 1,921,478 A1, for a Telecommunication Optical Fiber Cable (Tatat et al.); U.S. Pat. No. 7,702,204 for a Method for Manufacturing an Optical Fiber Preform (Gonnet et al.); U.S. Pat. No. 7,570,852 for an Optical Fiber Cable Suited for Blown Installation or Pushing Installation in Microducts of Small Diameter (Nothofer et al.); U.S. Pat. No. 7,646,954 for an Optical Fiber Telecommunications Cable (Tatat); U.S. Pat. No. 7,599,589 for a Gel-Free Buffer Tube with Adhesively Coupled Optical Element (Overton et al.); U.S. Pat. No. 7,567,739 for a Fiber Optic Cable Having a Water-Swellable Element (Overton); U.S. Pat. No. 7,817,891 for a Method for Accessing Optical Fibers within a Telecommunication Cable (Lavenne et al.); U.S. Pat. No. 7,639,915 for an Optical Fiber Cable Having a Deformable Coupling Element (Parris et al.); U.S. Pat. No. 7,646,952 for an Optical Fiber Cable Having Raised Coupling Supports (Parris); U.S. Pat. No. 7,724,998 for a Coupling Composition for Optical Fiber Cables (Parris et al.); U.S. Patent Application Publication No. US2009/0214167 A1 for a Buffer Tube with Hollow Channels, (Lookadoo et al.); U.S. Patent Application Publication No. US2009/0297107 A1 for an Optical Fiber Telecommunication Cable, filed May 15, 2009, (Tatat); U.S. Patent Application Publication No. US2009/0279833 A1 for a Buffer Tube with Adhesively Coupled Optical Fibers and/or Water-Swellable Element, filed Jul. 21, 2009, (Overton et al.); U.S. Patent Application Publication No. US2010/0092135 A1 for an Optical Fiber Cable Assembly, filed Sep. 10, 2009, (Barker et al.); U.S. Patent Application Publication No. US2010/0067857 A1 for a High-Fiber-Density Optical Fiber Cable, filed Sep. 10, 2009, (Louie et al.); U.S. Patent Application Publication No. US2010/0067855 A1 for a Buffer Tubes for Mid-Span Storage, filed Sep. 11, 2009, (Barker); U.S. Patent Application Publication No. US2010/

0135623 A1 for Single-Fiber Drop Cables for MDU Deployments, filed Nov. 9, 2009, (Overton); U.S. Patent Application Publication No. US2010/0092140 A1 for an Optical-Fiber Loose Tube Cables, filed Nov. 9, 2009, (Overton); U.S. Patent Application Publication No. US2010/0135624 A1 for a Reduced-Size Flat Drop Cable, filed Nov. 9, 2009, (Overton et al.); U.S. Patent Application Publication No. US2010/0092138 A1 for ADSS Cables with High-Performance Optical Fiber, filed Nov. 9, 2009, (Overton); U.S. Patent Application Publication No. US2010/0135625 A1 for Reduced-Diameter Ribbon Cables with High-Performance Optical Fiber, filed Nov. 10, 2009, (Overton); U.S. Patent Application Publication No. US2010/0092139 A1 for a Reduced-Diameter, Easy-Access Loose Tube Cable, filed Nov. 10, 2009, (Overton); U.S. Patent Application Publication No. US2010/0154479 A1 for a Method and Device for Manufacturing an Optical Preform, filed Dec. 19, 2009, (Milicevic et al.); U.S. Patent Application Publication No. US 2010/0166375 for a Perforated Water-Blocking Element, filed Dec. 29, 2009, (Parris); U.S. Patent Application Publication No. US2010/0183821 A1 for a UVLED Apparatus for Curing Glass-Fiber Coatings, filed Dec. 30, 2009, (Hart-suiker et al.); U.S. Patent Application Publication No. US2010/0202741 A1 for a Central-Tube Cable with High-Conductivity Conductors Encapsulated with High-Dielectric-Strength Insulation, filed Feb. 4, 2010, (Ryan et al.); U.S. Patent Application Publication No. US2010/0215328 A1 for a Cable Having Lubricated, Extractable Elements, filed Feb. 23, 2010, (Tatat et al.); U.S. Patent Application Publication No. US2011/0026889 A1 for a Tight-Buffered Optical Fiber Unit Having Improved Accessibility, filed Jul. 26, 2010, (Risch et al.); U.S. Patent Application Publication No. US2011/0064371 A1 for Methods and Devices for Cable Insertion into Latched Conduit, filed Sep. 14, 2010, (Leatherman et al.); U.S. Patent Publication No. 2011/0069932 A1 for a High-Fiber-Density Optical-Fiber Cable, filed Oct. 19, 2010, (Overton et al.); U.S. Patent Publication No. 2011/0091171 A1 for an Optical-Fiber Cable Having High Fiber Count and High Fiber Density, filed Oct. 19, 2010, (Tatat et al.); U.S. patent application Ser. No. 13/009,118 for a Water-Soluble Water-Blocking Element, filed Jan. 19, 2011, (Parris); U.S. patent application Ser. No. 13/096,178 for a Data-Center Cable, filed Apr. 28, 2011, (Louie et al.); and U.S. patent application Ser. No. 13/099,663 for a Bundled Fiber Optic Cables, filed May 3, 2011, (Quinn et al.).

* * *

In the specification and/or figures, typical embodiments of the invention have been disclosed. The present invention is not limited to such exemplary embodiments. The use of the term “and/or” includes any and all combinations of one or more of the associated listed items. The figures are schematic representations and so are not necessarily drawn to scale. Unless otherwise noted, specific terms have been used in a generic and descriptive sense and not for purposes of limitation.

The invention claimed is:

1. An apparatus for curing a coated glass fiber, comprising:
 - a substantially closed, substantially cylindrical cavity having a substantially elliptical cross-section and a reflective inner surface, said cavity defining a first line focus, a second line focus, and a major axis intersecting the first line focus and the second line focus, the second line focus defining a curing axis;

- a protective tube that is substantially transparent to ultraviolet (UV) radiation, said protective tube surrounding the curing axis; and
- an ultraviolet light emitting diode (UVLED) source positioned within said cavity at the first line focus, wherein said UVLED source is configured to have (i) a substantially Lambertian emission pattern that defines a line of average emission L_{avg} and (ii) an emission angle α between the major axis and L_{avg} defined by the following equation:

$$\alpha \geq \theta_{source} / 2 + \arctan(r_{tube} / (2f)),$$

where

r_{tube} is the radius of the protective tube,

$2f$ is the distance between the first line focus and the second line focus, and

θ_{source} is the angle of the emittance cone of the UVLED source that contains 95 percent of the emitted power from the UVLED source.

2. The apparatus according to claim 1, wherein said cavity has an elliptical cross-section.
3. The apparatus according to claim 1, wherein said protective tube is a quartz tube.
4. The apparatus according to claim 1, wherein said UVLED source is a single UVLED.
5. The apparatus according to claim 1, wherein said UVLED source comprises of a plurality of UVLEDs.
6. The apparatus according to claim 5, wherein said plurality of UVLEDs comprises at least two UVLEDs that emit electromagnetic radiation at different output intensities.
7. The apparatus according to claim 1, comprising a plurality of UVLED sources positioned within said cavity.
8. The apparatus according to claim 7, wherein said plurality of UVLEDs sources comprises at least two UVLED sources that emit electromagnetic radiation at different output intensities.
9. The apparatus according to claim 1, wherein at least 90 percent of the electromagnetic radiation emitted by said UVLED source has wavelengths of between about 250 nanometers and 400 nanometers.
10. The apparatus according to claim 1, wherein at least 80 percent of the electromagnetic radiation emitted by said UVLED source has wavelengths of between about 300 nanometers and 450 nanometers.
11. The apparatus according to claim 1, wherein at least 80 percent of the electromagnetic radiation emitted by said UVLED source has wavelengths of between about 375 nanometers and 425 nanometers.
12. The apparatus according to claim 1, wherein said UVLED source emits electromagnetic radiation of wavelengths mostly between about 395 nanometers and 415 nanometers.
13. The apparatus according to claim 1, wherein at least 80 percent of the electromagnetic radiation emitted by said UVLED source has wavelengths within a 30-nanometer range.
14. The apparatus according to claim 1, wherein the emission angle α is between about 30 degrees and 120 degrees.
15. The apparatus according to claim 1, wherein the emission angle α is between 30 degrees and 60 degrees.
16. The apparatus according to claim 1, wherein the emission angle α is between about 40 degrees and 50 degrees.
17. A system for curing a coated glass fiber, comprising: a first apparatus and a second apparatus each according to claim 1;

19

wherein the first line focus of the first apparatus is distinct from the first line focus of the second apparatus; and wherein the second line focus of the first apparatus is the same as the second line focus of the second apparatus.

18. An apparatus for curing a coated glass fiber, comprising:

a substantially closed, substantially cylindrical cavity having a substantially elliptical cross-section and a reflective inner surface, said cavity defining a first line focus, a second line focus, and a major axis intersecting the first line focus and the second line focus, the second line focus defining a curing axis;

a protective tube that is substantially transparent to ultraviolet (UV) radiation, said protective tube surrounding the curing axis;

an ultraviolet light emitting diode (UVLED) source positioned within said cavity; and

a lens for focusing UV radiation from said UVLED source toward the first line focus, said lens positioned within said cavity;

wherein, at the first line focus, said UVLED source and said lens are together configured (i) to provide an emission pattern that defines a line of average emission Lavg and (ii) to have an emission angle α between the major axis and Lavg defined by the following equations:

$$\alpha \geq \theta_{source}/2 + \arctan(r_{tube}/(2f)), \text{ and}$$

$$\alpha \leq 2\pi - (\theta_{source}/2 + \arctan(r_{tube}/(2f))),$$

where

r_{tube} is the radius of the protective tube,

$2f$ is the distance between the first line focus and the second line focus, and

θ_{source} is the angle of the emittance cone that contains 95 percent of the power directed from the first line focus.

19. The apparatus according to claim 18, wherein the emission angle α is between 30 degrees and 120 degrees.

20

20. An apparatus for curing a coated glass fiber, comprising:

a substantially closed, substantially cylindrical cavity having a substantially elliptical cross-section and a reflective inner surface, said cavity defining a first line focus, a second line focus, and a major axis intersecting the first line focus and the second line focus, the second line focus defining a curing axis;

a protective tube that is substantially transparent to ultraviolet (UV) radiation, said protective tube surrounding the curing axis;

an ultraviolet light emitting diode (UVLED); and an optical fiber having a first end and a second end;

wherein the first end of said optical fiber is coupled to said UVLED source;

wherein the second end of said optical fiber is positioned within said cavity at the first line focus, the second end of said optical fiber configured (i) to provide an emission pattern that defines a line of average emission Lavg and (ii) to have an emission angle α between the major axis and Lavg defined by the following equations:

$$\alpha \geq \theta_{source}/2 + \arctan(r_{tube}/(2f)), \text{ and}$$

$$\alpha \leq 2\pi - (\theta_{source}/2 + \arctan(r_{tube}/(2f))),$$

where

r_{tube} is the radius of the protective tube,

$2f$ is the distance between the first line focus and the second line focus, and

θ_{source} is the angle of the emittance cone that contains 95 percent of the power directed by said optical fiber from the first line focus.

21. The apparatus according to claim 20, wherein the emission angle α is between 30 degrees and 150 degrees.

* * * * *