

(12) **United States Patent**
Lieponis

(10) **Patent No.:** **US 9,675,235 B2**
(45) **Date of Patent:** **Jun. 13, 2017**

(54) **MULTI-PURPOSE SURGICAL INSTRUMENT WITH REMOVABLE COMPONENT**

(76) Inventor: **Jonas V. Lieponis**, Guilford, CT (US)

(*) Notice: Subject to any disclaimer, the term of this patent is extended or adjusted under 35 U.S.C. 154(b) by 1867 days.

(21) Appl. No.: **12/421,191**

(22) Filed: **Apr. 9, 2009**

(65) **Prior Publication Data**
US 2009/0221991 A1 Sep. 3, 2009

Related U.S. Application Data

(63) Continuation-in-part of application No. 11/757,707, filed on Jun. 4, 2007, now Pat. No. 7,842,027, which is a continuation-in-part of application No. 11/384,843, filed on Mar. 20, 2006.

(60) Provisional application No. 60/663,690, filed on Mar. 21, 2005.

(51) **Int. Cl.**
A61M 39/02 (2006.01)
A61B 1/015 (2006.01)
A61B 1/00 (2006.01)
A61M 1/00 (2006.01)
A61B 90/30 (2016.01)
A61M 27/00 (2006.01)
A61M 31/00 (2006.01)
A61M 29/00 (2006.01)

(52) **U.S. Cl.**
CPC **A61B 1/015** (2013.01); **A61B 1/00105** (2013.01); **A61B 1/00165** (2013.01); **A61B 1/00167** (2013.01); **A61B 90/30** (2016.02); **A61M 1/008** (2013.01); **A61B 2090/306** (2016.02)

(58) **Field of Classification Search**
USPC 604/540, 544, 95.03, 95.04, 96.01
See application file for complete search history.

(56) **References Cited**

U.S. PATENT DOCUMENTS

3,261,356 A	7/1966	Wallace
3,780,736 A	12/1973	Chen
3,916,948 A	11/1975	Benjamin
4,204,328 A	5/1980	Kutner
4,551,130 A	11/1985	Herbert et al.
4,617,013 A	10/1986	Betz
4,782,819 A	11/1988	Adair
4,872,837 A	10/1989	Issalene et al.
4,992,047 A	2/1991	Warner
5,026,367 A	6/1991	Leckrone et al.
5,201,730 A	4/1993	Easley et al.
5,213,092 A	5/1993	Uram

(Continued)

OTHER PUBLICATIONS

Threaded connector (2001).*

(Continued)

Primary Examiner — Tatyana Zalukaeva
Assistant Examiner — Ilya Treyger
(74) *Attorney, Agent, or Firm* — St. Onge Steward Johnston & Reens, LLC

(57) **ABSTRACT**

A combination aspiration/irrigation and illumination device using optical fibers circumferentially disposed around the aspiration conduit for transmitting illuminating light to a cavity to be aspirated. The aspiration conduit having a tip that is detachably affixed to and end of the aspiration conduit. The optical fibers terminated at a distance (d) from a distal end of the tip. Also provided is an image fiber(s) for transmitting image data from the distal end of the device.

27 Claims, 10 Drawing Sheets

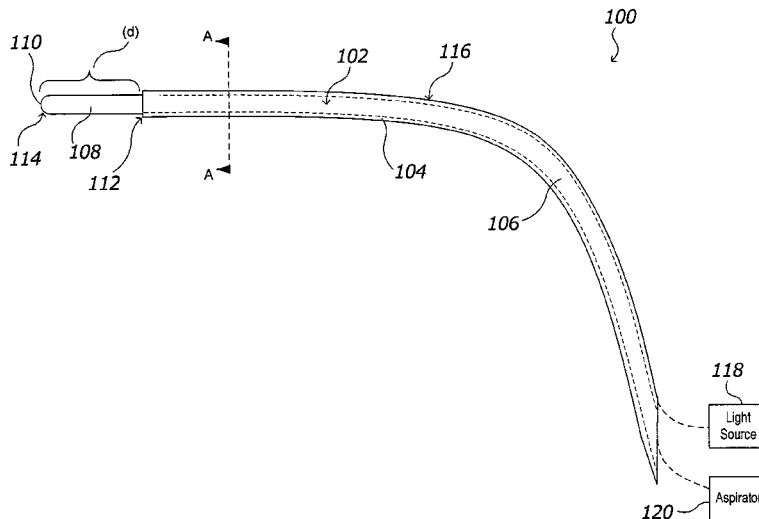

(56)

References Cited

U.S. PATENT DOCUMENTS

5,415,653	A	5/1995	Wardle et al.	
5,588,952	A	12/1996	Dandolu	
5,931,670	A	8/1999	Davis	
6,007,776	A	12/1999	Matsumoto	
6,572,578	B1 *	6/2003	Blanchard	604/22
2003/0153897	A1	8/2003	Russo	

OTHER PUBLICATIONS

LED (2000).*
The American Heritage® Dictionary of the English Language,
Fourth Edition, 2000.*

* cited by examiner

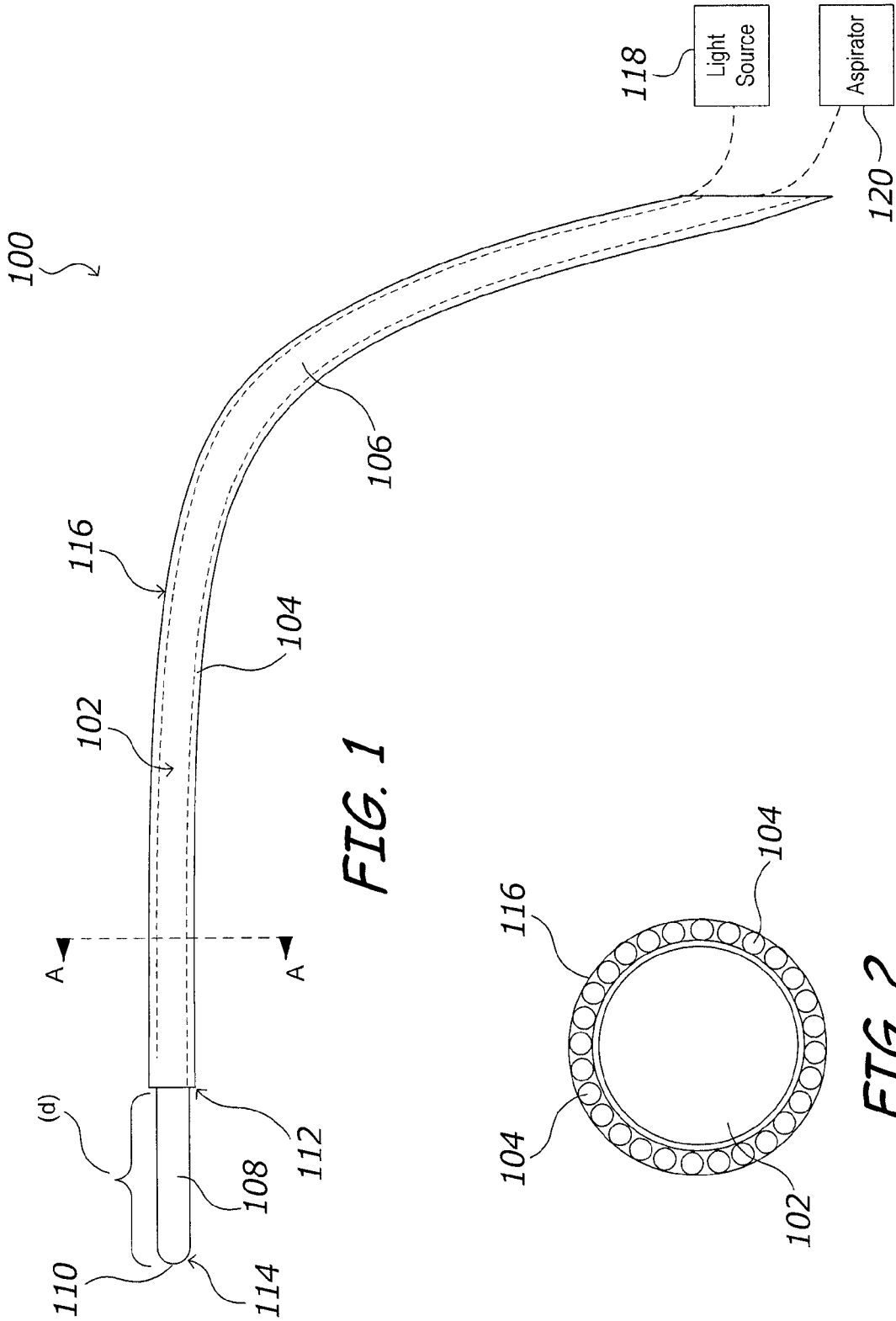

FIG. 1

FIG. 2

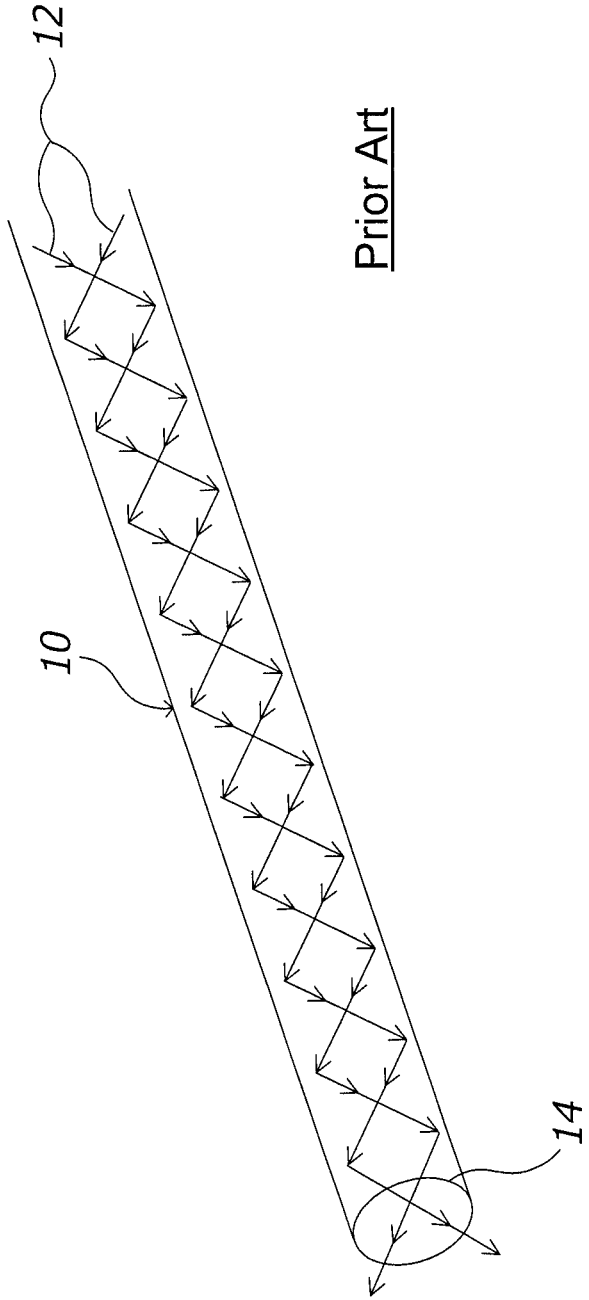

FIG. 3

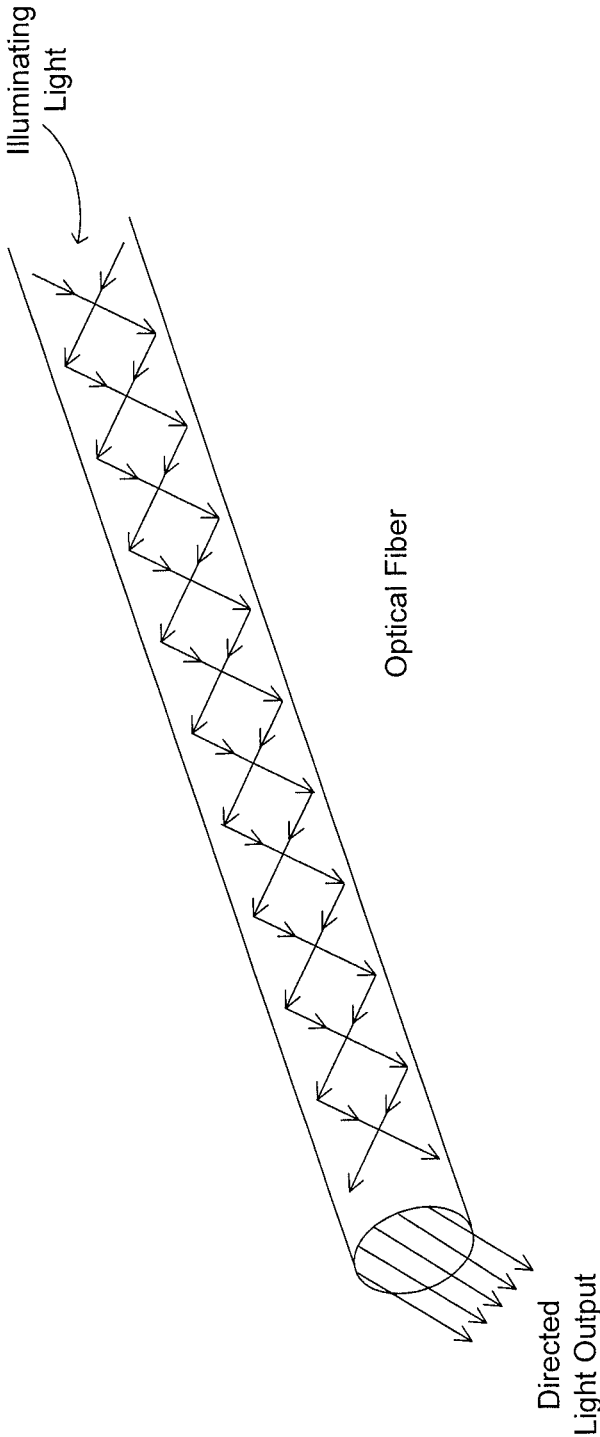

FIG. 4

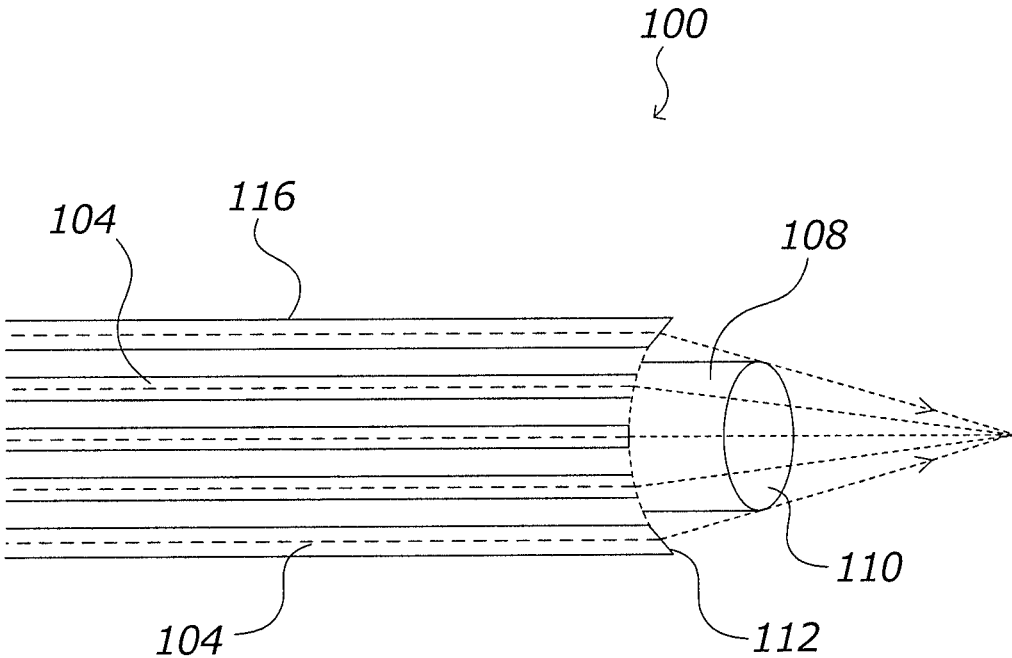

FIG. 5

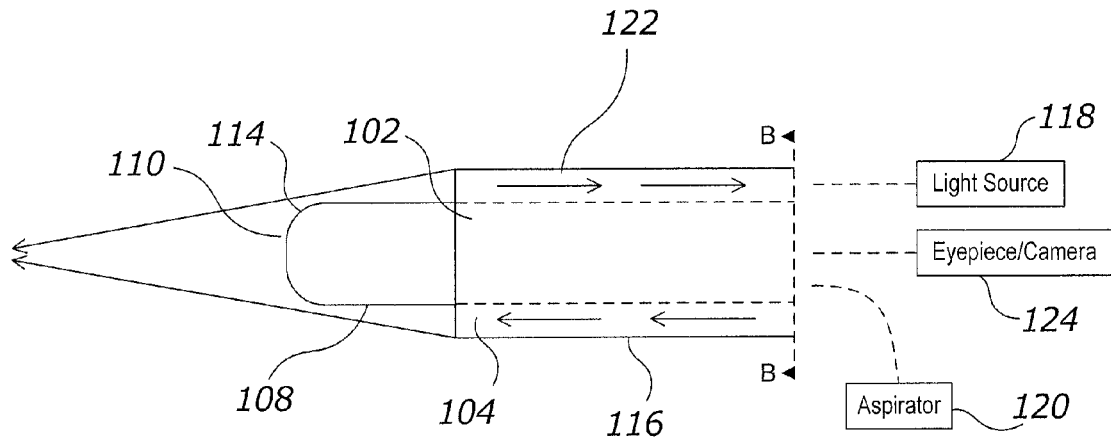

FIG. 6

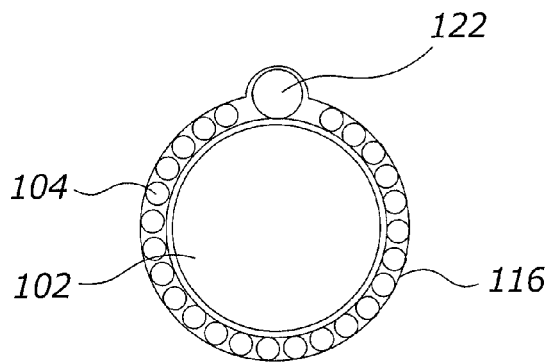

FIG. 7

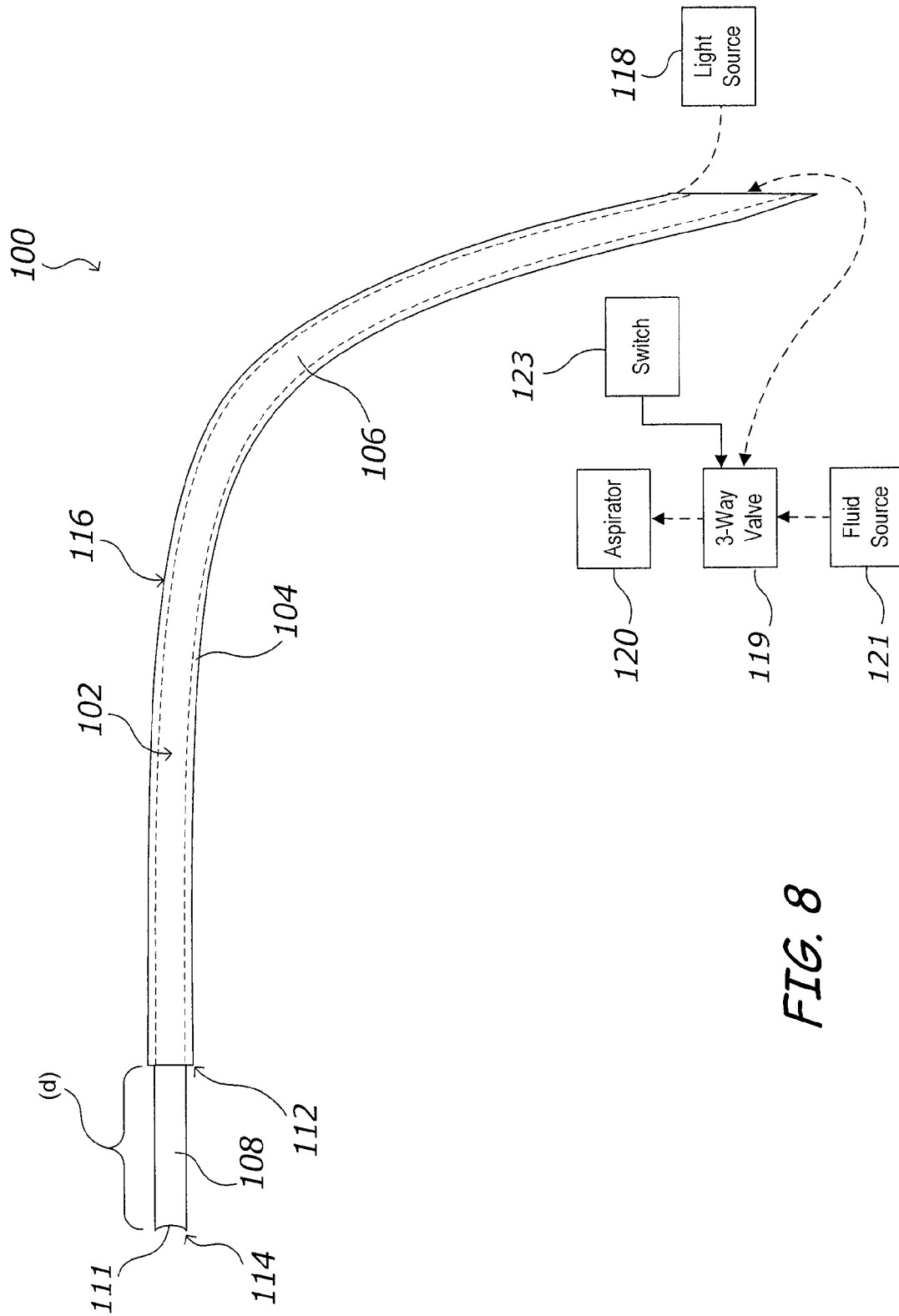

FIG. 8

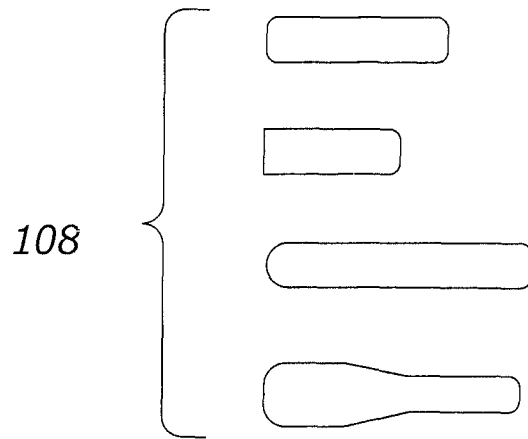

FIG. 9

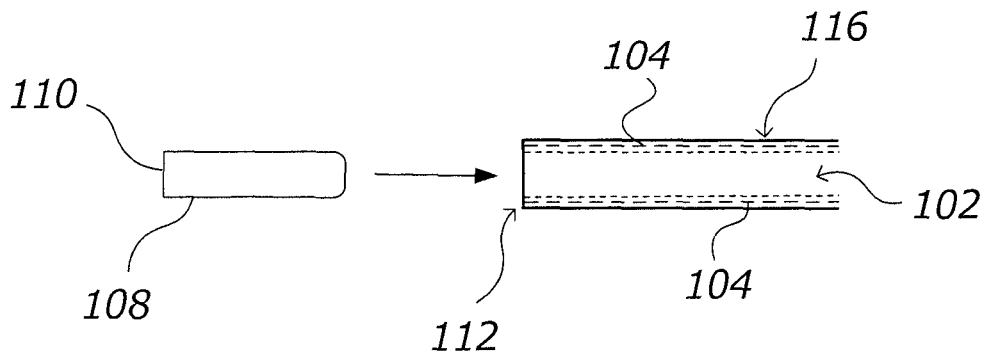

FIG. 10

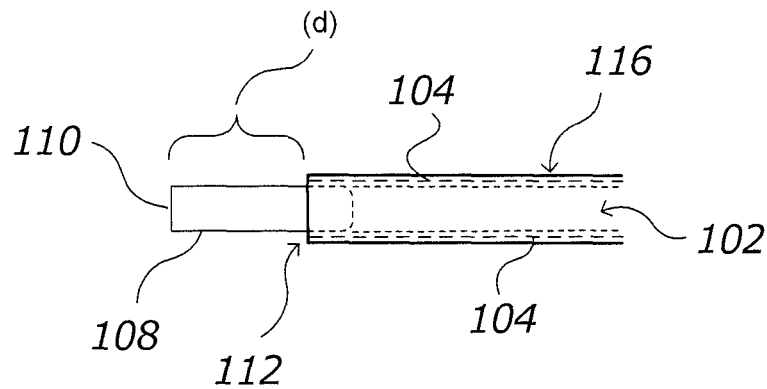

FIG. 11

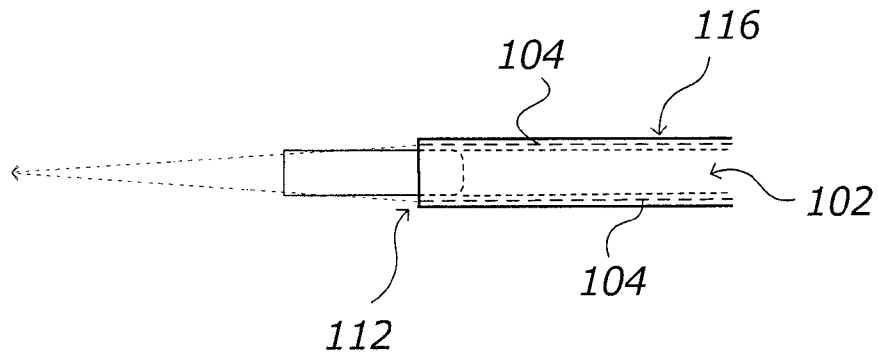

FIG. 12

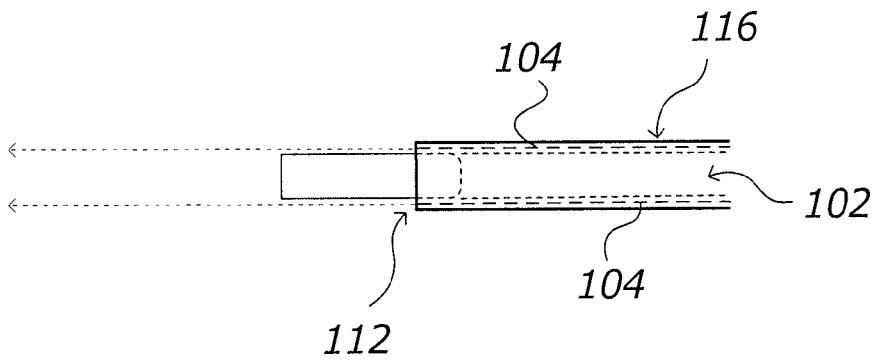

FIG. 13

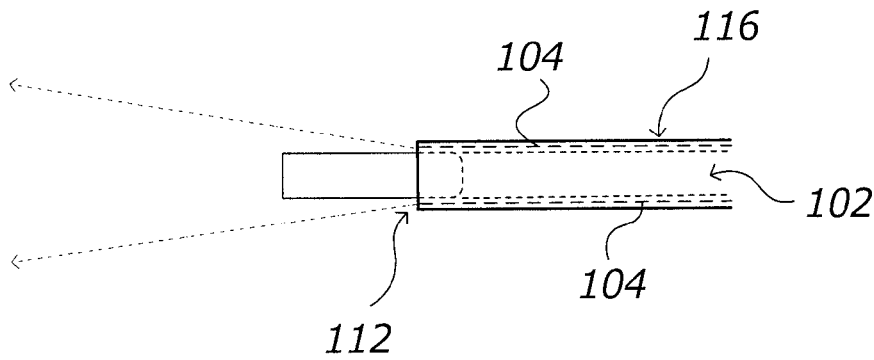

FIG. 14

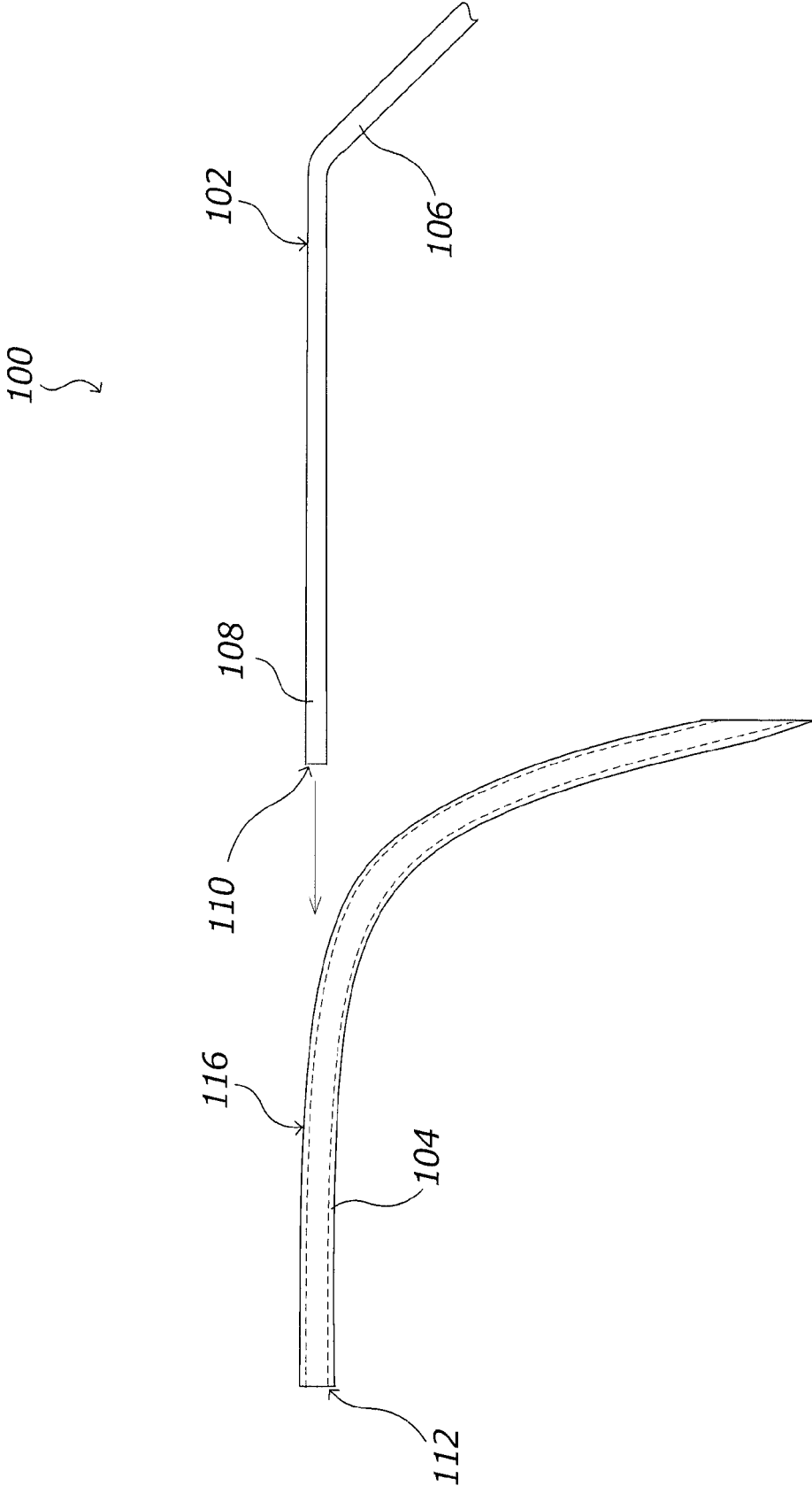

FIG. 15a

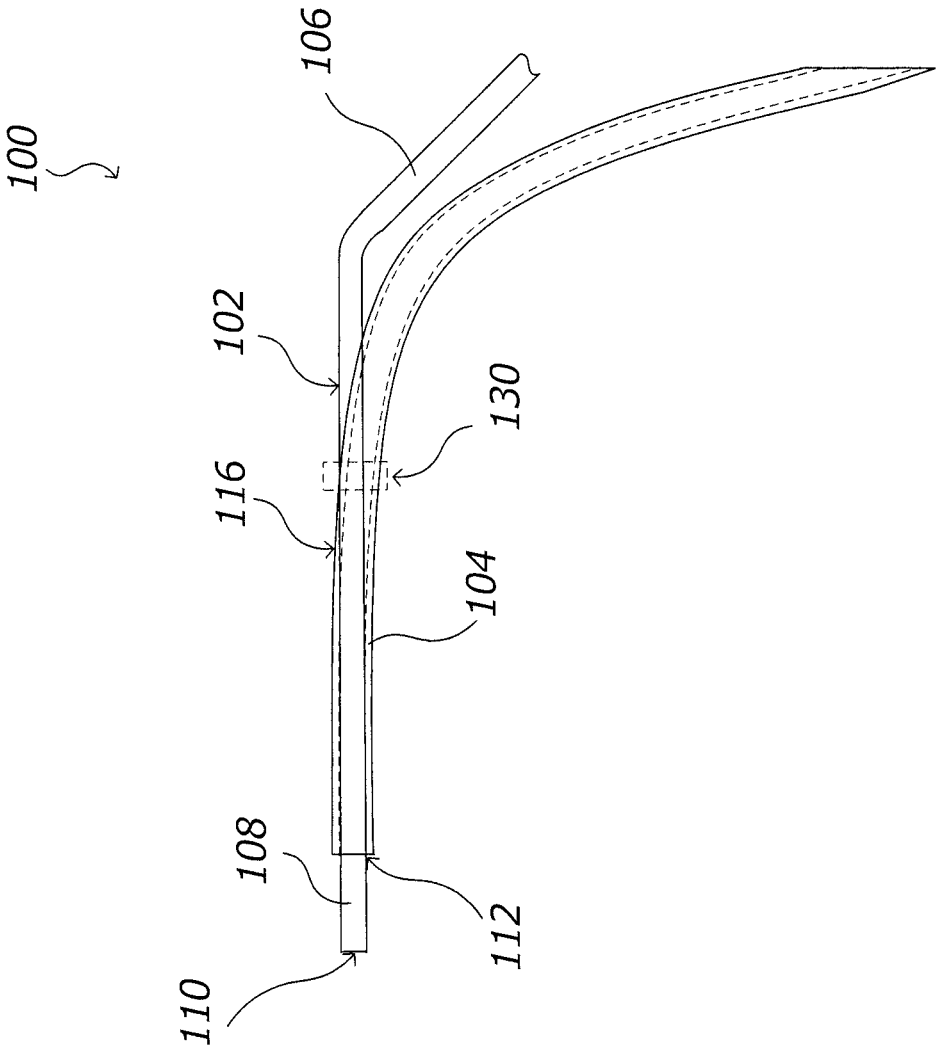

FIG. 15b

MULTI-PURPOSE SURGICAL INSTRUMENT WITH REMOVABLE COMPONENT

CROSS-REFERENCE TO RELATED APPLICATIONS

This application is a continuation-in-part of U.S. patent application Ser. No. 11/757,707 filed Jun. 4, 2007 now U.S. Pat. No. 7,842,027, which is a continuation-in-part of U.S. patent application Ser. No. 11/384,843 filed on Mar. 20, 2006, which claims the benefit of the filing date of U.S. Patent Application Ser. No. 60/663,690 filed Mar. 21, 2005.

FIELD OF THE INVENTION

This invention relates to a surgical instrument, more specifically this invention relates to a combination suction/irrigation device and optical device that may provide a visual indication of the area in which the tool is inserted.

BACKGROUND OF THE INVENTION

Minimally invasive surgery provides some significant advantages over open surgical procedures and as such, is being more frequently utilized. However, minimally invasive surgery and surgical techniques, for example, minimal incision surgery such as is utilized in spinal procedures, have created a special set of requirements with regard to the visualization of the operative field. These special requirements or changed parameters include the operative field being significantly reduced in size as compared to open surgical procedures. However, the depth parameter for the surgical procedure has remained unchanged. Therefore, the incision size to incision depth ratio has been markedly decreased very often geometrically creating unique challenges for the surgeon.

For example, unique geometry of the reduced size of the incision places severe constraints on the space available for the placement of surgical instruments in the area where the procedure is being performed. Visualization of the surgical area is also severely limited due to among other things, the size of the incision. As such, the size and number of surgical instruments that may be simultaneously used during minimally invasive surgical procedures is quite limited.

Additionally, minimally invasive surgical techniques typically require suction to be placed or located almost directly adjacent to the operative site. The proximity of the suction and visualization devices creates additional challenges relating to: design and material choice, and cost of manufacture/purchase. For example, especially when performing procedures with relatively small space constraints such as for example minimally invasive surgery, frequently requires the surgeon to utilize relatively high-speed abrasive rotating instruments. With relatively tight space constraints, this type of cutting tool may frequently come into contact with other surgical devices positioned within the surgical area. It is not uncommon for the other surgical devices to become damaged by this incidental contact. This can become quite costly for the hospital/surgeon to have to regularly repair and/or replace expensive surgical equipment in this manner.

Another problem with know illumination systems is the generation of heat at the light exit location due to the relatively large amount of optical energy exiting the device. Excessive heat in a surgical area should be avoided as it can lead to congealing of blood and in certain cases, burning of the surrounding tissue.

A number of previous systems have attempted to address a few of these problems with limited success. For example, U.S. Pat. No. 5,588,952 (“Dandolu”) discloses a combination illumination and aspiration device. Dandolu further discloses that “reflector” is positioned at the tip of the device to diffuse and focus the emitted light from the side wall of the device. However, Dandolu fails to teach or suggest a system that projects illuminating light ahead of the suction tip. Rather, Dandolu discloses that a fiber optic cable emits light out of a side portion of the device, perpendicular to the longitudinal axis of the suction device. Additionally, Dandolu concentrates the optical exit point of the illuminating light thereby generating excessive heat, which is highly undesirable.

U.S. Pat. No. 4,872,837 (“Issalene et al.”) discloses an instrument capable of both illumination and aspiration. Issalene et al. further teaches use of a cannula having a beveled front end that may be used to concentrate and/or direct illuminating light in a controlled manner. However, Issalene et al. fails to teach or suggest a system that includes a plurality of optical fibers surrounding an aspiration tube to maximize the light projected ahead of the suction tip or that the optical fibers terminate a distance from the tip such that in the event of damage to the tip, the optical fibers are not damaged. Additionally, Issalene et al. provides a single optical point of illumination that will generate excessive heat.

U.S. Pat. No. 5,213,092 (“Uram”) discloses a combination aspiration and illumination/image guiding system. However, Uram positions the illuminating/image guides and aspiration tube side-by-side, which disadvantageously increases the overall size of the device. With minimally invasive surgical procedures, it is critical that the device remain a small in diameter as reasonably possible. Accordingly, Uram fails to teach a combination suction and illumination device that presents one concentric system to provide the smallest diameter possible. In addition, as the illumination guide is offset from the suction tube, such that illumination of the area ahead of the device will suffer.

Therefore, what is desired is a surgical system and method that provides for increased visualization in the surgical area while at the same time not further restricting the working area for the surgeon.

It is further desired to provide a surgical system and method that may effectively be utilized in connection with minimally invasive surgery that provides for increased visualization of the area where the surgical procedure is to be performed.

It is still further desired to provide a surgical system and method that minimizes the number of surgical tools that must be simultaneously inserted into the incision.

It is yet further desired to provide a surgical system and method that reduces the costs of suction and visualization tools.

It is also desired to provide a surgical system that allows the user to position the device in various angles and locations despite having limited access to the area as is the case in non-invasive surgical procedures.

It is further desired to provide a surgical system and method that provides illuminating light to a surgical area while minimizing any amount of heat that may be generated by the illuminating light.

SUMMARY OF THE INVENTION

These and other objectives are achieved by provision of a surgical device that combines the applications of visualiza-

tion and suction into a single instrument. Illuminating light is transmitted down the length of the device by means of optical fibers, which are concentrically positioned around an aspiration tube. The optical fibers are terminated at a distance from the tip of the device, which may be provided as

a transparent, translucent or opaque material. Additionally, in one advantageous embodiment, the optical fibers are machined at an angle relative to the longitudinal axis of the optical fiber to increase illumination of a particular area. In one advantageous embodiment, the angle may range from about 45° to about 70° from the longitudinal axis. Still further, it is contemplated that multiple optical fibers with angled ends may be provided to concentrate the light inwardly with respect to the suction tube to provide increased illumination to an area ahead of the tip of the device.

For this application the following terms and definitions shall apply:

The term “network” as used herein includes both networks and internetworks of all kinds, including the Internet, and is not limited to any particular network or inter-network.

The terms “coupled”, “coupled to”, and “coupled with” as used herein each mean a relationship between or among two or more devices, apparatus, files, programs, media, components, networks, systems, subsystems, and/or means, constituting any one or more of (a) a connection, whether direct or through one or more other devices, apparatus, files, programs, media, components, networks, systems, subsystems, or means, (b) a communications relationship, whether direct or through one or more other devices, apparatus, files, programs, media, components, networks, systems, subsystems, or means, and/or (c) a functional relationship in which the operation of any one or more devices, apparatus, files, programs, media, components, networks, systems, subsystems, or means depends, in whole or in part, on the operation of any one or more others thereof.

The combined visualization and suction device provides a number of significant advantages over previous systems. For example, in minimally invasive surgery, the incision size is greatly reduced but the depth of the incision remains constant with open surgical procedures. This means the angle at which the surgical instruments enter and are placed in the procedure area is relatively large (i.e., approaching perpendicular). Therefore, the fewer instruments simultaneously inserted into the incision and the smaller in diameter each instrument, the greater flexibility the surgeon has to manipulate the surgical instruments.

The combination of suction and visualization instruments into one surgical device provides the distinct advantage of alleviating space constraints for the surgeon, especially is this so when the outside diameter (OD) of the combination instrument is essentially the same size as a suction only tool or perhaps only marginally larger.

In another advantageous embodiment, the suction tip of the combination device is provided made of a transparent or translucent material such that visual obstruction to the work area is minimized. The configuration of the fiber optic strands may be selected such that they may be used to effectively illuminate the work area while not providing an obstruction to visualization.

In still another advantageous embodiment, the optical fibers may be positioned such that the illuminating light is focused inward, toward a point located ahead of the tip of the tip. Optical fibers that are cut at a 90 degree angle or perpendicular to the longitudinal axis of the optical fiber, typically permit the light to exit the end of the fiber in a random fashion due to the inherently random reflection and

refraction of the light propagating in the optical fiber. However, it is contemplated the exit ends of the optical fibers may be cut or machined at an angle relative to the longitudinal axis so as to direct the light to the shorter side of the oblique fiber end. In one advantageous embodiment, the cut or machined angle end may range from about 70 degrees to about 45 degrees.

Advantageously, the optical fibers may be positioned about the circumference of the suction tube in such a manner as to focus the illuminating light inward toward the center of the visual field directly ahead of the tip. To accomplish this, the optical fibers may be positioned with the oblique ends of the optical fibers facing inward toward the visual field.

To achieve uniformity of angle in the various optical fibers, the optical fibers may be cut or machined by adhering the optical fibers to a sheet of material and then cutting or machining the ends at a uniform angle. The optical fibers may then be applied or adhered to a suction cannula providing all of the fibers at a uniform orientation facing toward the visualization field to maximize illumination.

It is further conceived that the combination surgical device be kept as inexpensive to manufacture as reasonably possible such that incidental contact and damage caused to the combination surgical device will not greatly impact operating costs. To accomplish this, the combination surgical tool may be provided as a disposable device providing for reduced costs.

Another problem faced by surgeons in tight operating environments is that when a relatively high-speed abrasive rotating instrument comes into contact with another surgical tools, particles can be produced, which cannot subsequently be removed from the surgical area. This is especially undesirable if the particles are metallic because they may produce artifacts on post-operative imaging studies. Therefore, it is further contemplated that in one embodiment the combination surgical device may be made from non-metallic materials. In other embodiments, the combination surgical device may comprise a metallic material or alloy.

While the invention has been thus far focused on providing the combination of a suction and illuminating surgical device, it is further contemplated that the device may yet further be provided with coherent optical fibers for receiving reflected light to be transmitted to the surgeon. This reflected light may be provided directly to the surgeon via, for example, an eye piece, or may be transmitted to a camera, which may then generate a video signal representative of the area ahead of the suction tip. In this manner the combination surgical device may fully serve as the suction and visualization device.

In one advantageous embodiment, a medical instrument for providing illuminating light to and aspiration of a cavity is provided comprising an aspiration conduit coupled to an aspirator for aspirating fluid and particles from the cavity, the aspiration conduit having a distal end with a concave tip. The instrument further comprises a plurality of optical fibers coupled to a light source and circumferentially positioned about the aspiration conduit for transmitting illuminating light to the cavity, the plurality of optical fibers extending along a length of the aspiration conduit. The instrument is provided such that the optical fibers are provided with distal ends having an angled surface relative to a longitudinal axis of the aspiration conduit such that the illuminating light transmitted by the optical fibers is directed radially inward relative to the aspiration conduit.

In another advantageous embodiment, a medical instrument for providing illuminating light to and aspiration of a cavity is provided comprising an aspiration conduit for

5

aspirating fluid and particles from the cavity, a valve coupled to the aspiration conduit, an aspirator coupled to the valve, a fluid source coupled to the valve and a switch connected to the valve. The instrument is provided such that the valve may selectively be switched to fluidly couple between the aspirator and the aspiration conduit or the fluid source and the aspiration conduit. The instrument further comprises a plurality of optical fibers coupled to a light source and circumferentially positioned about the aspiration conduit for transmitting illuminating light to the cavity.

In still another advantageous embodiment, a method for selectively clearing a clogged combination illumination/aspiration medical instrument is provided comprising the steps of coupling an aspiration conduit to a valve, coupling an aspirator to the valve and coupling a fluid source to the valve. The method further comprises the steps of selectively aspirating a cavity and clearing the device by switching the valve to couple between the aspiration conduit and the aspirator or the aspiration conduit and the fluid source. Finally, the method comprises the steps of positioning a plurality of optical fibers circumferentially about the aspiration conduit and illuminating an area ahead of a distal end of the optical fibers.

In a further advantageous embodiment, a medical instrument for providing illuminating light to and aspiration of a cavity is provided comprising an aspiration conduit coupled to an aspirator for aspirating fluid and particles from the cavity, the aspiration conduit having a distal end and a detachable tip affixed to the distal end. The medical instrument further comprises a plurality of optical fibers coupled to a light source and circumferentially positioned about the aspiration conduit for transmitting illuminating light to the cavity, the plurality of optical fibers extending along a length of the aspiration conduit.

In another advantageous embodiment, a medical instrument for providing illuminating light to and aspiration of a cavity is provided where the device comprises an aspiration conduit coupled to an aspirator for aspirating fluid and particles from the cavity, the aspiration conduit having a distal end. The medical instrument further comprises a sheath enclosing a plurality of optical fibers, the plurality of optical fibers positioned circumferentially about a cavity located along a longitudinal axis of the sheath. The optical fibers have distal ends from which illuminating light exits. The medical instrument also comprises a light source coupled to proximal ends of the plurality of optical fibers. The medical instrument is provided such that the aspiration conduit is insertable into the cavity so that the distal end of the aspiration conduit is adjustable relative to the distal ends of the plurality of optical fibers.

In still another advantageous embodiment, the medical instrument is further provided with a locking device to lock the aspiration conduit in a position relative to the distal ends of the optical fibers.

Other objects of the invention and its particular features and advantages will become more apparent from consideration of the following drawings and accompanying detailed description.

BRIEF DESCRIPTION OF THE DRAWINGS

FIG. 1 is an illustration of one advantageous embodiment of the present invention.

FIG. 2 is a cross-sectional view along line AA according to FIG. 1.

FIG. 3 is an illustration of an optical fiber with an end cut or machined at a nominal 90° angle.

6

FIG. 4 is an illustration of an optical fiber according to FIG. 2 with an end cut or machined at an angle relative to the longitudinal axis of the optical fiber

FIG. 5 is an illustration according to FIG. 2 of the optical fibers transmitting illuminating light to a point ahead of the tip of the device.

FIG. 6 is an illustration of another advantageous embodiment of the present invention.

FIG. 7 is a cross-sectional view along line BB according to FIG. 6.

FIG. 8 is an illustration of another advantageous embodiment of the present invention.

FIG. 9 is an illustration of various tip configurations that may be used with the aspiration and illumination device.

FIG. 10 is an illustration of a selected tip prior to attachment to the aspiration and illumination device.

FIG. 11 is an illustration of the aspiration and illumination device according to FIG. 10 with the tip attached.

FIGS. 12-14 are illustrations of various embodiments according to FIG. 4.

FIGS. 15a-15b are illustrations of the advantageous embodiment according to FIG. 1.

DETAILED DESCRIPTION OF THE INVENTION

Referring now to the drawings, wherein like reference numerals designate corresponding structure throughout the views.

FIG. 1 depicts aspiration and illumination device 100 according to one advantageous aspect of the present invention. Aspiration and illumination device 100 generally comprises aspiration conduit 102 and optical fibers 104. As illustrated in FIG. 2 along section line AA, optical fibers 104 are positioned circumferentially about aspiration conduit 102.

Aspiration conduit 102, in one advantageous embodiment, preferably comprises a non-metallic substance such as, for example, a flexible plastic material. It is further contemplated that aspiration conduit 102 may be provided of a material that can hold a shape when deformed providing increased control for the surgeon.

As can be seen in FIG. 1, aspiration conduit 102 comprises a body portion 106 and a tip 108, the tip 108 provided with a distal end 110. In one advantageous embodiment, tip 108 is provided as a transparent or at least, a translucent material, which will reduce any shadowing that, may occur or obstruct the surgeon's view of the cavity (not shown). Tip 108 is provided with an opening therein to allow for the introduction of fluids and particles therein to provide aspiration of the cavity as desired. The rate of aspiration is controlled by the surgeon via means commonly used in the art.

It may further be noted from FIG. 1 that optical fibers 104 are terminated at a distance (d) from distal end 110. The ends 112 of optical fibers 104 are positioned circumferentially about tip 108. As tip 108 is provided as a transparent or translucent material, the illuminating light exiting ends 112 will not be impeded but can travel along a length of tip 108 and may even travel through a portion of tip 108 to illuminate the cavity (not shown).

It is further contemplated that distal end 110 may, in another advantageous embodiment, be provided with rounded contour edges 114, however, it is contemplated that many differing configurations may be utilized for distal end 110. It is still further contemplated that the distance (d) may be varied depending upon the application and use.

Still further provided is sheath **116**, which is provided enclosing both aspiration conduit **102** and optical fibers **104**. Sheath **116** may comprise virtually any desired material that can enclose and protect optical fibers **104** while still allowing deflection of aspiration and illumination device **100**. As shown in FIG. **1**, sheath **116** may in one advantageous embodiment, terminate at or near ends **112** of optical fibers **104** so as not to interfere with the illuminating light exiting optical fibers **104**.

Also shown in FIG. **1** are light source **118** and aspirator **120**. Light source **118** is provided to generate illuminating light that is coupled into optical fibers **104** for transmission to the cavity. Light source **118** may comprise, in one advantageous embodiment, a Light Emitting Diode(s) (LED). In addition, aspirator **120** is illustrated coupled to aspiration conduit **102**. As previously discussed, the rate of aspiration is controlled by the surgeon and may comprise a pre-selected flow rate, a controlled variable flow rate and/or combinations thereof.

As can be seen from FIGS. **1** and **2**, the diameter of aspiration and illumination device **100** is kept to a minimum as optical fibers **104** are closely positioned about aspiration conduit **102** and enclosed by a relatively thin sheath **116**. This provides a distinct advantage over prior art devices. For example, in minimally invasive surgery, while the incision size is reduced, the depth of the incision remains constant with open surgical procedures. This means that the angle at which the surgical instruments enter and are placed in the procedure area is relatively large (i.e. the instruments are positioned almost straight up and down relative to the incision). Therefore, the smaller in diameter each instrument, the greater flexibility the surgeon has to manipulate the surgical instruments.

Referring now to FIG. **3**, we see an optical fiber **10** as is known in the prior art. As illustrated, illuminating light **12** is coupled into optical fiber **10** in a known manner. The illuminating light **12** is transmitted down optical fiber **10** in a manner corresponding to the construction of the particular optical fiber **10**. An end **14** of optical fiber **10** is shown formed as a 90° angle with respect to the longitudinal axis of optical fiber **10**. As illustrated, the illuminating light **12** exiting end **14** exits in a scattered fashion providing a relatively wide illumination pattern.

Alternatively, turning now to FIG. **4** it can be seen that optical fiber **104**, while similar to optical fiber **10**, differs in that end **112** is formed at an angle relative to the longitudinal axis of optical fiber **104**. In this manner, illuminating light, rather than exiting end **112** in a scattered fashion, is generally directed as indicated. In this manner, increased illumination of a particular area may be achieved. It should be noted that, while the light is shown exiting the end of the angled end **112** of the optical fiber **104** at a 45 degree angle relative to the longitudinal axis, it is contemplated that the end **112** may be shaped to a wide variety of angles (e.g. 45° to about 70° from the longitudinal axis) may be selected depending upon the application and procedure to be performed.

It should be noted that, while U.S. Pat. No. 4,872,837 ("Issalene et al.") discloses a cannula having a beveled front end that may be used to concentrate and/or direct illuminating light in a somewhat controlled manner, Issalene et al. fails to teach a device that can concentrate illuminating light in front of an aspirating tube.

This is illustrated in FIG. **5**. For example, aspiration and illumination device **100** is shown with the ends **112** of optical fiber **104** having beveled edges. In this advantageous embodiment, the illuminating light that exits ends **112** is

directed inward relative to aspiration conduit **102**. The optical fibers **104** are concentrically positioned about aspiration conduit **102** and are positioned such that the beveled ends **112** all face inward. In this manner, the directed light focuses at a point ahead of distal end **110** providing for increased light output in the cavity for the surgeon.

Again, the distal end may be provided as a transparent or translucent material to prevent interference with the light output and distal end **110** may be provided with as either a flat end or with a rounded contour. Sheath **116** is shown terminating prior to beveled ends **112** so as not to interfere with the illuminating light exiting therefrom.

Turning now to FIGS. **6** and **7** we see an alternative embodiment of the present invention illustrated. This embodiment is similar in operation as that illustrated in connection with FIGS. **1** and **2** except, that image optical fiber(s) **122** is illustrated adjacent to the optical fibers **104**. This can be seen with reference to FIG. **7**, which is a cross-sectional view taken along line BB in FIG. **6**. The entire device is encased in sheath **116** as previously described.

Image optical fibers **122** may comprise, for example, a single flexible optical fiber or may comprise coherent optical fibers that can pick up light reflected from the cavity and transmit the reflected light along image optical fiber(s) **122** back to an eyepiece or camera **124**. In this manner, not only can the surgeon transmit illuminating light to the cavity with a combination aspiration and illumination device, but can further reduce the number of surgical tools in the incision by using the same tool to transmit image data. This may be especially effective where a camera is utilized and the surgeon is provided with a video display (not shown) for viewing the surgical procedure.

Like the embodiment disclosed in FIGS. **1** and **2**, it is contemplated that the device including the image optical fiber may also be flexible and hold a shape upon deformation. Further, the device may comprise non-metallic compositions and be of a disposable nature. In this manner, accidental contact with, for example, rotating cutting devices will not result in metallic particles being left in the cavity or require sterilization.

The combination aspiration and illumination device then provides a relatively small compact device for the surgeon, which reduces the number and size of tools used during minimally invasive surgical procedures. In addition, the disposable device allows for increased flexibility of use and is cost effective.

Referring now to FIG. **8**, an alternative embodiment for the configuration of tip **108** is provided. In this embodiment, tip **108** is provided with distal end **110** that is provided as a concave end **111** rather than the rounded contour edges as depicted in FIG. **1**. This provides that distinct advantage of providing a multi-purpose tool for the surgeon when, for example, the surgeon is suturing an area. This is because the concave end can be used to hold it down while the surgeon is completing the suture. The concave surface will act to maintain the suture on the concave end **111** while the suture is tied off.

It is contemplated that tip **108** in this embodiment may again be provided as a transparent or translucent material as described in connection with FIG. **1**.

Also illustrated in FIG. **8** is 3-way valve **119**, which is variously coupled to aspirator **120** and fluid source **121**. In this advantageous embodiment, 3-way valve **119** is provided with a switch **123** that is operated by the physician to switch between "aspiration mode" in which the aspirator is fluidly coupled through 3-way valve **119** to aspiration conduit **102**

and “irrigation mode” in which fluid source 121 is fluidly coupled through 3-way valve 119 to aspiration conduit 102. It is contemplated that aspiration conduit 102 may, at times, become either partially or fully clogged during a procedure. In order to clear the obstruction, the surgeon has the option to actuate switch 123 to switch 3-way valve 119 to “irrigation mode” where pressurized fluid from fluid source 121 is fed into aspiration conduit 102 to dislodge the obstruction.

It is contemplated that switch 123 may be located on 3-way valve 119, or may be located on aspiration and illumination device 100. The connection between switch 123 and 3-way valve 119 may comprise a hard-wired or a wireless connection. In addition, it is contemplated that the surgeon may, in still another embodiment, control the pressure of the fluid transmitted to aspiration conduit 102. In this manner, the surgeon may provide irrigation in an area where a procedure is being performed as desired and may then switch back to aspiration mode. Alternatively, the surgeon may remove aspiration and illumination device 100 from the area where a procedure is being performed in the event of an obstruction in aspiration conduit 102, and may blow the obstruction out via relatively high pressure fluid from fluid source 121.

FIG. 9 is an illustration of various tips 108 provided for attachment to aspiration conduit 102 within aspiration and illumination device 100. It is contemplated that the various tips 108 may comprise many differing configurations, including, for example but not limited to, a concave or a convex tip configuration, various lengths, various shapes (cylinders, frusto-cones, paddle-shaped, etc.), and various diameters. It is further contemplated that the various tips 108 may be provided comprising various materials that may be selected depending upon the procedure and may include, for example, but not limited to, a clear or translucent plastic or polymer, a metal or alloy, an opaque material, a flexible or pliable material, or a rigid material. In any event, the particular tip 108 may be interchanged for any other tip 108 allowing for a more flexible system for the physician. The tips 108 may be provided as single or multiple use components, and may be provided as a packaged supply of various tips 108 or sold and supplied individually.

FIGS. 10 and 11 illustrate the attachment of a tip 108 to aspiration and illumination device 100. The tip 108 may be provided with an outer diameter that is marginally smaller than an inner diameter of aspiration conduit 102. The selected tip 108 may be provided as a friction fit having a slightly expanding diameter such that upon advancement of the tip 108 in aspiration conduit 102, the tip becomes firmly seated as is illustrated in FIG. 11. Alternatively, the tip 108 may be provided as a threaded or rotatable adapter that may be rotated into a secure position, such as, for example, a luer-type locking arrangement. For example, it is contemplated that the tip 108 may be rotated into a locked secure position and may be detached by reverse rotation of the tip 108.

The removable tip 108 provides greater versatility for the physician, but also provides for replacement of the tip 108 if it becomes damaged due to, for example, inadvertent contact with cutting equipment used in the surgical area. Additionally, the termination of the optical fibers 104 at a distance (d) from distal end 110 serves to protect the optical fibers 104 from inadvertent damage. The circumferential positioning of the fibers allows for increased illumination of the surgical area.

Referring now to FIGS. 12-14, it is contemplated that the ends of the optical fibers may be machined to direct the light exiting therefrom in virtually any direction desired. For

example, the optical fibers may be machined at substantially a 90° angle relative to the longitudinal axis of the fiber or at an angle thereto. It is further contemplated that the angle could be provided so as to direct the illuminating light radially inward toward a point ahead of the tip 108, or to direct the light radially outward to broadly illuminate the surgical area.

FIGS. 15a and 15b illustrate yet another embodiment of the present invention where the aspiration conduit 102 is removable from the sheath 116 enclosing the optical fibers 104. For example, FIG. 15a shows that the aspiration conduit 102 may be inserted (removable from) into the sheath 116 from a rear portion thereof. As shown in FIG. 15b, the aspiration conduit 102 is fully inserted into the sheath 116 and the tip 108 including distal end 110 extends a distance (d) from the ends 112 of the optical fibers 104. In this manner the optical system could be used, for example, with virtually any standard suction device and can be used with various sized suction devices. Additionally, while the suction device may be disposable, the optical components could be sterilized and used multiple times.

It is further contemplated that the suction device may be “lockable” to engage with the optical components to vary the distance the ends of the optical fibers 104 are positioned from distal end 110. The locking mechanism 139 may comprise virtually any type of locking device, including, but not limited to, frictional fitting, a clamp, fitting, or the like.

Although the invention has been described with reference to a particular arrangement of parts, features and the like, these are not intended to exhaust all possible arrangements or features, and indeed many other modifications and variations will be ascertainable to those of skill in the art.

What is claimed is:

1. A medical instrument for providing illuminating light to and aspiration of a cavity, the device comprising:
 - an aspiration pipe coupleable to an aspirator, said aspiration pipe having a conduit passing therethrough and a distal tip terminating the conduit, said conduit being coaxial with said pipe and having an opening coaxial with the conduit and positioned at the distal tip;
 - a sheath enclosing a plurality of optical fibers, said plurality of optical fibers positioned circumferentially about a cavity located along a longitudinal axis of said sheath, said optical fibers having distal ends for illuminating light to exit;
 - said plurality of optical fibers coupleable a light source;
 - said aspiration pipe is insertable into said cavity such that said distal end of said aspiration pipe is adjustable relative to said distal ends of said plurality of optical fibers.
2. The medical instrument according to claim 1 further comprising a locking device to lock said aspiration pipe in a position relative to the distal ends of the optical fibers.
3. The medical instrument according to claim 2 where said locking device is selected from the group consisting of: frictional fitting, a clamp, a fitting and combinations thereof.
4. The medical instrument according to claim 1 wherein said aspiration pipe and said plurality of optical fibers are flexible.
5. The medical instrument according to claim 4 wherein upon deflection of said aspiration pipe and said plurality of optical fibers, said medical instrument will retain the deformed shape.
6. The medical instrument according to claim 1 wherein said light source comprises and LED.
7. A medical instrument for providing illuminating light to and aspiration of a cavity, the device comprising:

11

an aspiration pipe coupled to an aspirator, said aspiration pipe having a conduit passing therethrough and a distal tip terminating the conduit, said conduit being coaxial with said pipe and having an opening coaxial with the conduit and positioned at the distal tip;

a detachable tip affixed to the distal tip;

a plurality of optical fibers coupled to a light source and circumferentially positioned about said aspiration pipe for transmitting illuminating light to the cavity, said plurality of optical fibers extending along a length of said aspiration pipe.

8. The medical instrument according to claim 7 wherein said plurality of optical fibers terminates a distance (d) from the distal tip.

9. The medical instrument according to claim 8 wherein said detachable tip is manufactured from a material selected from the group consisting of: plastic, a polymer, stainless steel, an alloy and combinations thereof.

10. The medical instrument according to claim 7 wherein an outer diameter of a first end of said detachable tip is provided having a smaller diameter than a diameter of said conduit.

11. The medical instrument according to claim 10 wherein said detachable tip is friction fit into said conduit.

12. The medical instrument according to claim 10 wherein said detachable tip is rotationally secured into said conduit.

13. The medical instrument according to claim 7 wherein said aspiration pipe and said plurality of optical fibers are flexible.

14. The medical instrument according to claim 13 wherein upon deflection of said aspiration pipe and said plurality of optical fibers, said medical instrument will retain the deformed shape.

15. The medical instrument according to claim 7 wherein said light source comprises and LED.

16. A medical instrument for providing illuminating light to and aspiration of a cavity, the device comprising:

an aspiration pipe coupled to an aspirator, said aspiration pipe having a conduit passing therethrough and a distal tip terminating the conduit, said conduit being coaxial with said pipe and having an opening coaxial with the conduit and positioned at the distal tip;

a plurality of optical fibers, said plurality of optical fibers positioned about an exterior surface of said aspiration pipe along a longitudinal axis of said aspiration pipe, said optical fibers having proximal and distal ends;

a light source coupled to said proximal ends of said plurality of optical fibers with a length of illumination cable;

said distal ends of said optical fibers terminating a distance (d) from said distal tip of said conduit;

12

a covering surrounding said aspiration pipe and said plurality of optical fibers.

17. The medical instrument according to claim 16 wherein said plurality of optical fibers are positioned about said aspiration conduit in at least a 180 degree arc around said aspiration pipe.

18. The medical instrument according to claim 16 wherein said plurality of optical fibers are positioned about said aspiration pipe in at least a 270 degree arc around said aspiration pipe.

19. The medical instrument according to claim 16 wherein said plurality of optical fibers are positioned circumferentially to completely surround said aspiration pipe.

20. The medical instrument according to claim 16 wherein at least a portion of said aspiration pipe is flexible.

21. The medical instrument according to claim 16 wherein at least a portion of said aspiration pipe is non-flexible.

22. A medical instrument for providing illuminating light to and aspiration of a cavity, the device comprising:

an aspiration pipe coupleable to an aspirator, said aspiration pipe having a generally cylindrical sidewall defining a conduit and having an end face defining a distal most point of said pipe, said conduit having an opening positioned in the end face;

a plurality of optical fibers, said plurality of optical fibers positioned about an exterior surface of said aspiration pipe, said optical fibers coupleable to a light source; said plurality of optical fibers terminating a distance (d) from the end face;

a covering surrounding said aspiration pipe and said plurality of optical fibers.

23. The medical instrument according to claim 22 wherein at least a portion of said aspiration pipe is flexible.

24. The medical instrument according to claim 22 wherein said covering surrounding said aspiration pipe defines a cavity positioned along a longitudinal length of said covering, and said aspiration pipe is insertable into the cavity such that the end face of said conduit is adjustable relative to distal ends of said plurality of optical fibers.

25. The medical instrument according to claim 24 further comprising a locking device to lock said end face in a position relative to the distal ends of the optical fibers.

26. The medical instrument according to claim 22 wherein said plurality of optical fibers are positioned about said aspiration conduit in at least a 180 degree arc around said aspiration pipe.

27. The medical instrument according to claim 22 wherein upon deflection of said aspiration pipe and said plurality of optical fibers, said medical instrument will retain the deformed shape.

* * * * *