



US009643096B1

(12) **United States Patent**
McDonald et al.

(10) **Patent No.:** **US 9,643,096 B1**
(45) **Date of Patent:** ***May 9, 2017**

(54) **ASSEMBLY WITH OBJECT IN HOUSING AND MECHANISM TO OPEN HOUSING**

(58) **Field of Classification Search**
USPC ... 446/4, 153, 175, 295, 296, 309, 310, 311, 446/312, 330, 336
See application file for complete search history.

(71) Applicant: **SPIN MASTER LTD.**, Toronto (CA)

(56) **References Cited**

(72) Inventors: **David McDonald**, Mississauga (CA);
Anne N. Charbonneau, North York (CA);
Hamid R. Hashemi, Mississauga (CA);
Victor Lai, Unionville (CA)

U.S. PATENT DOCUMENTS

(73) Assignee: **SPIN MASTER LTD.**, Toronto (CA)

608,794 A	8/1898	Quinn	
3,005,284 A	10/1961	Angelo	
3,091,053 A	5/1963	Growald	
4,736,943 A	4/1988	Fukuda	
4,817,936 A	4/1989	Matsuda	
4,836,821 A	6/1989	Raymond	
4,881,915 A *	11/1989	Liaw	A63H 33/00 428/16

(*) Notice: Subject to any disclaimer, the term of this patent is extended or adjusted under 35 U.S.C. 154(b) by 0 days.

This patent is subject to a terminal disclaimer.

(Continued)

(21) Appl. No.: **15/262,526**

OTHER PUBLICATIONS

(22) Filed: **Sep. 12, 2016**

U.S. Appl. No. 14/884,191, Non-Final Office Action, Oct. 28, 2016, USPTO.

(Continued)

Related U.S. Application Data

Primary Examiner — Kurt Fernstrom

(63) Continuation of application No. 15/227,740, filed on Aug. 3, 2016, which is a continuation-in-part of application No. 15/199,341, filed on Jun. 30, 2016, which is a continuation-in-part of application No. 14/884,191, filed on Oct. 15, 2015, now Pat. No. 9,550,128.

(74) *Attorney, Agent, or Firm* — Millman IP Inc.

(51) **Int. Cl.**
A63H 33/00 (2006.01)
A63H 3/36 (2006.01)
A63H 29/22 (2006.01)
A63H 3/00 (2006.01)

(57) **ABSTRACT**

In an aspect, a toy assembly is provided, and includes a housing, an inner object, at least one sensor and a controller. The inner object is positioned inside the housing and includes a breakout mechanism that is operable to break the housing to expose the inner object. The at least one sensor detects interaction with a user. The controller is configured to determine whether a selected condition has been met based on at least one interaction with the user, and to operate the breakout mechanism to break the housing to expose the inner object if the condition is met. Optionally, the condition is met based upon having a selected number of interactions with the user.

(52) **U.S. Cl.**
CPC **A63H 3/36** (2013.01); **A63H 3/006** (2013.01); **A63H 29/22** (2013.01); **A63H 2200/00** (2013.01)

15 Claims, 37 Drawing Sheets

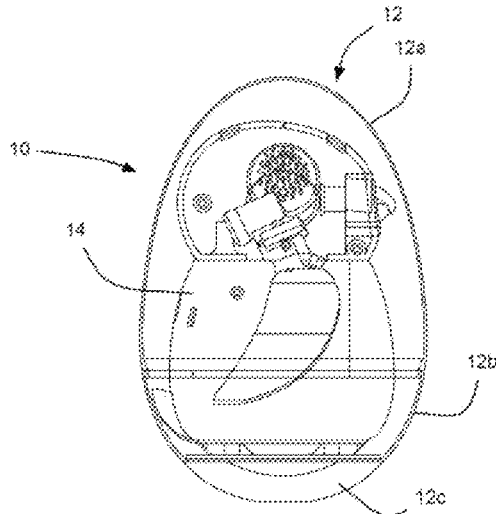

(56)

References Cited

U.S. PATENT DOCUMENTS

5,813,895	A	9/1998	Cho	
6,231,346	B1 *	5/2001	Sagi-Dolev	G09B 19/00 434/225
6,592,426	B2 *	7/2003	Mesch	A63H 13/16 446/175
6,702,644	B1	3/2004	Hornsby	
2007/0173170	A1	7/2007	Wu	

OTHER PUBLICATIONS

Mitsubishi, K. et al., "Mechanical properties of polyethylene/ethylene vinyl acetate filled with calcium carbonate", *Polymer Composites* (Impact Factor: 1.63). Apr. 1988; 9(2). DOI: 10.1002/pc.750090203, abstract accessed Jan. 29, 2016.

* cited by examiner

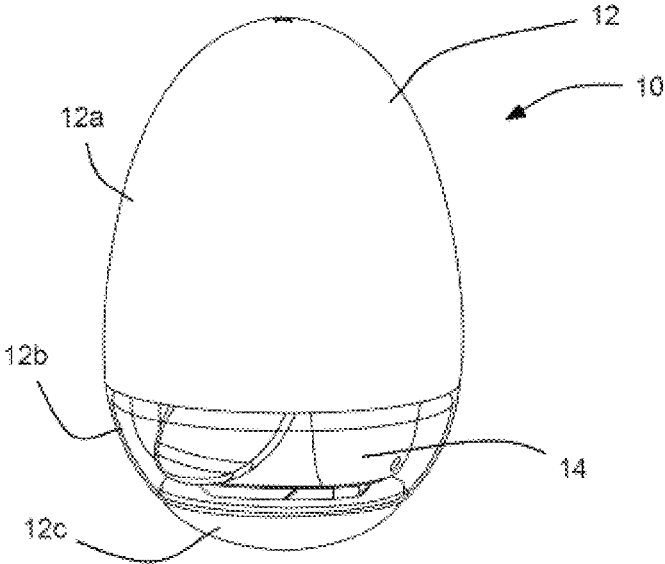

FIG. 1A

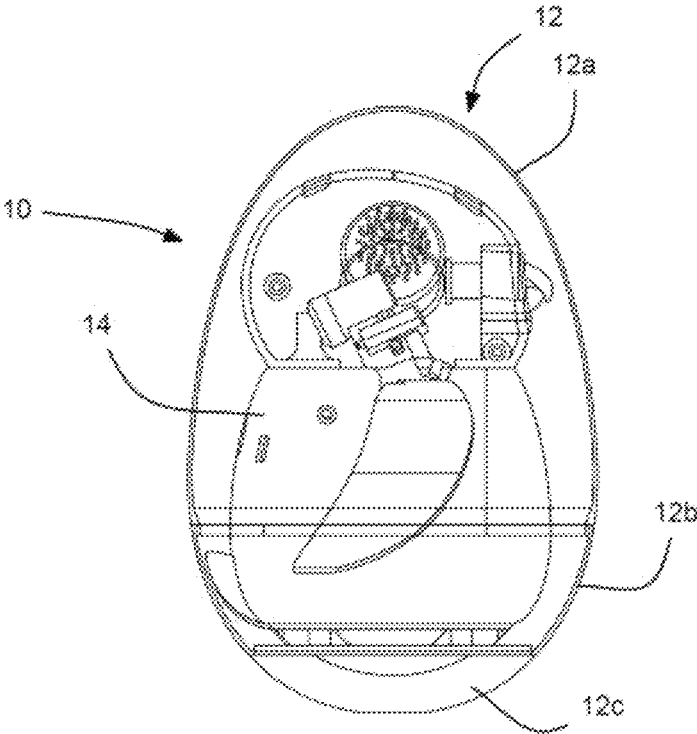
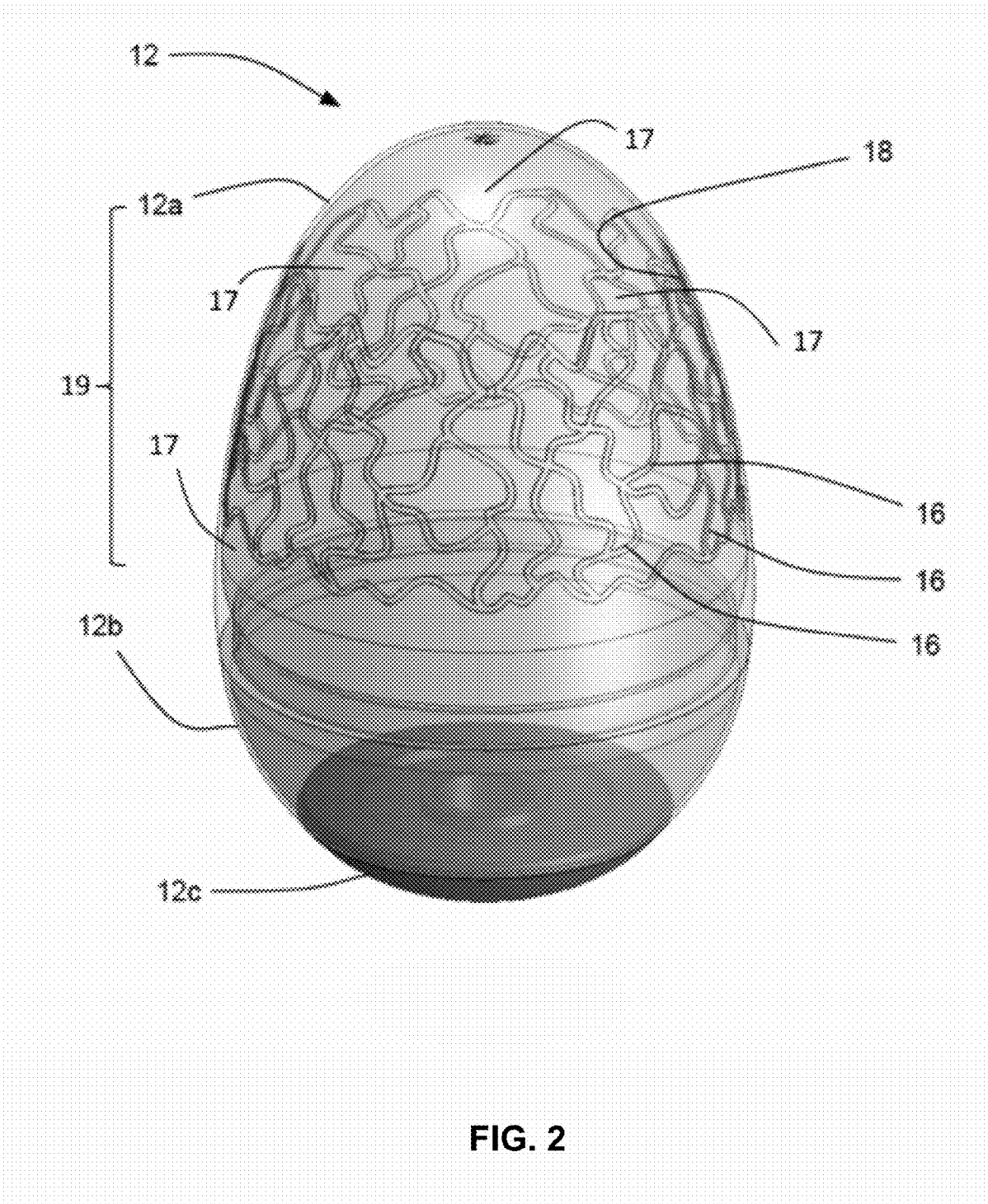

FIG. 1B



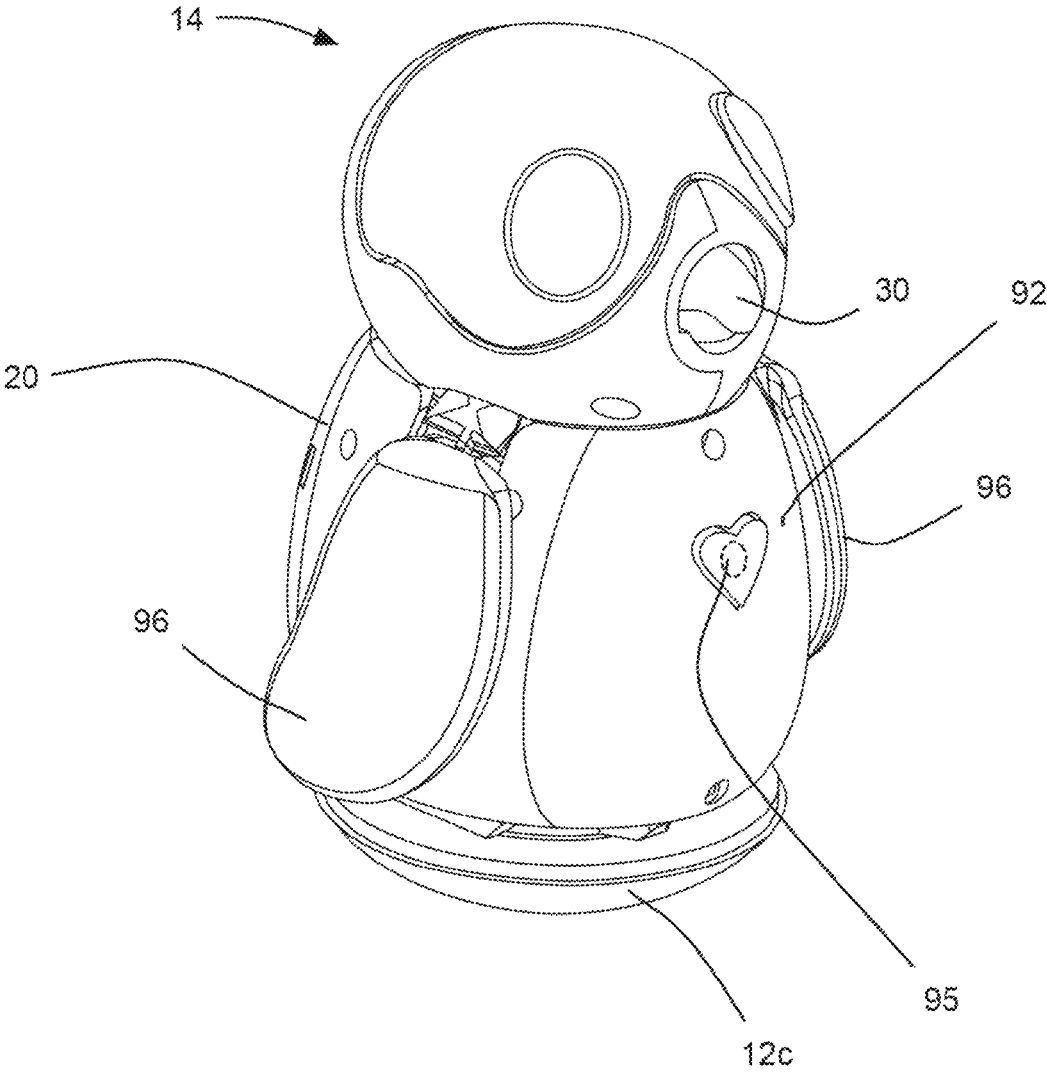

FIG. 3

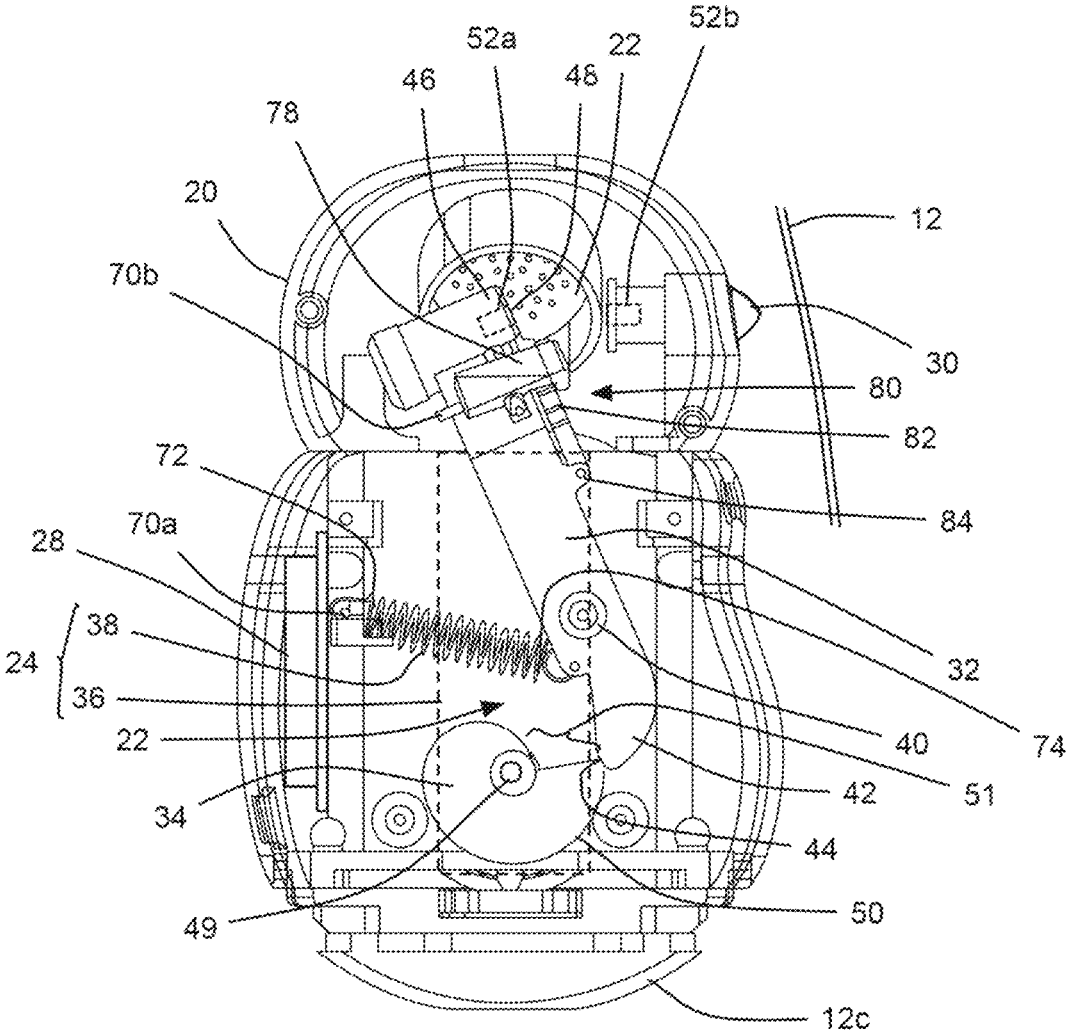

FIG. 4

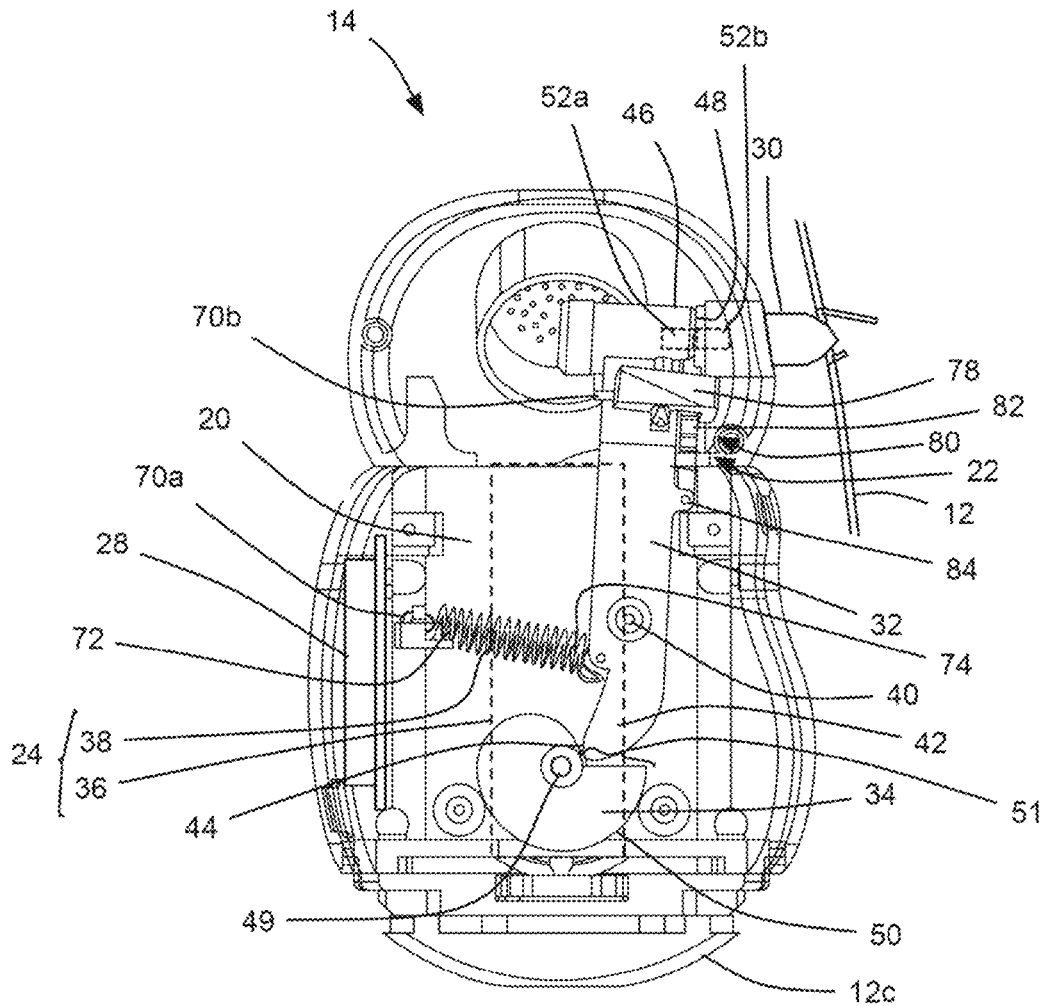

FIG. 5

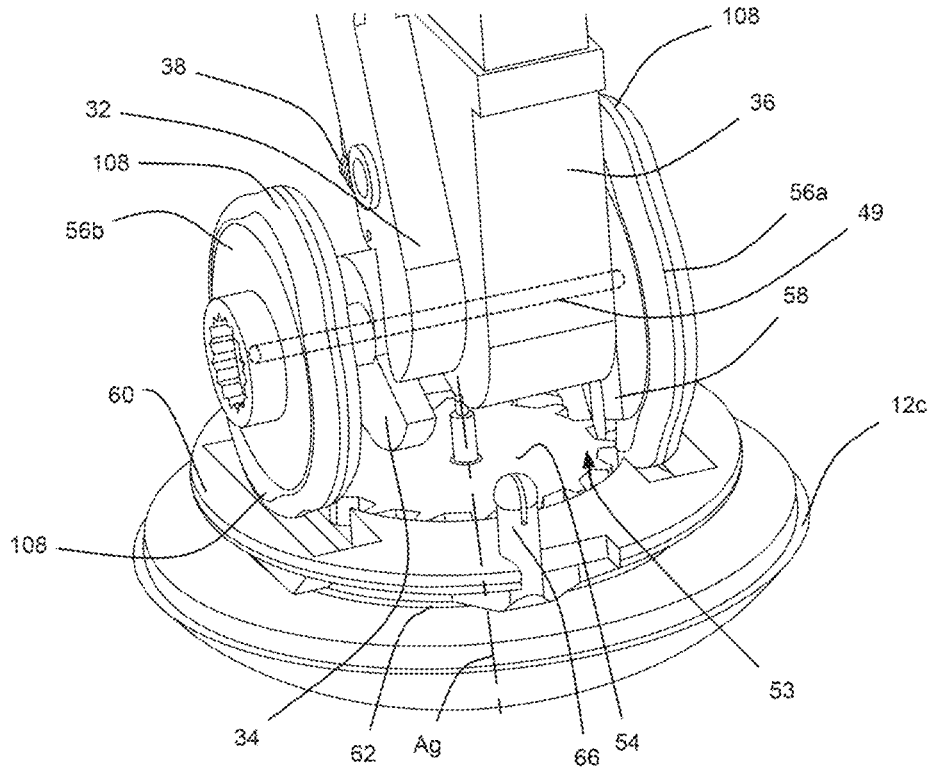

FIG. 6

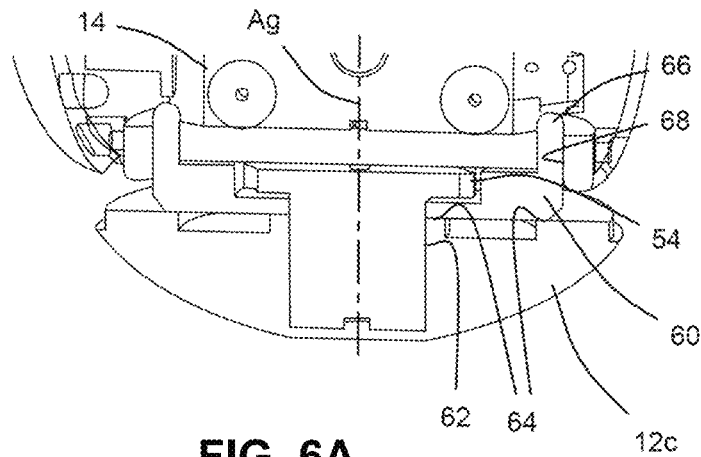

FIG. 6A

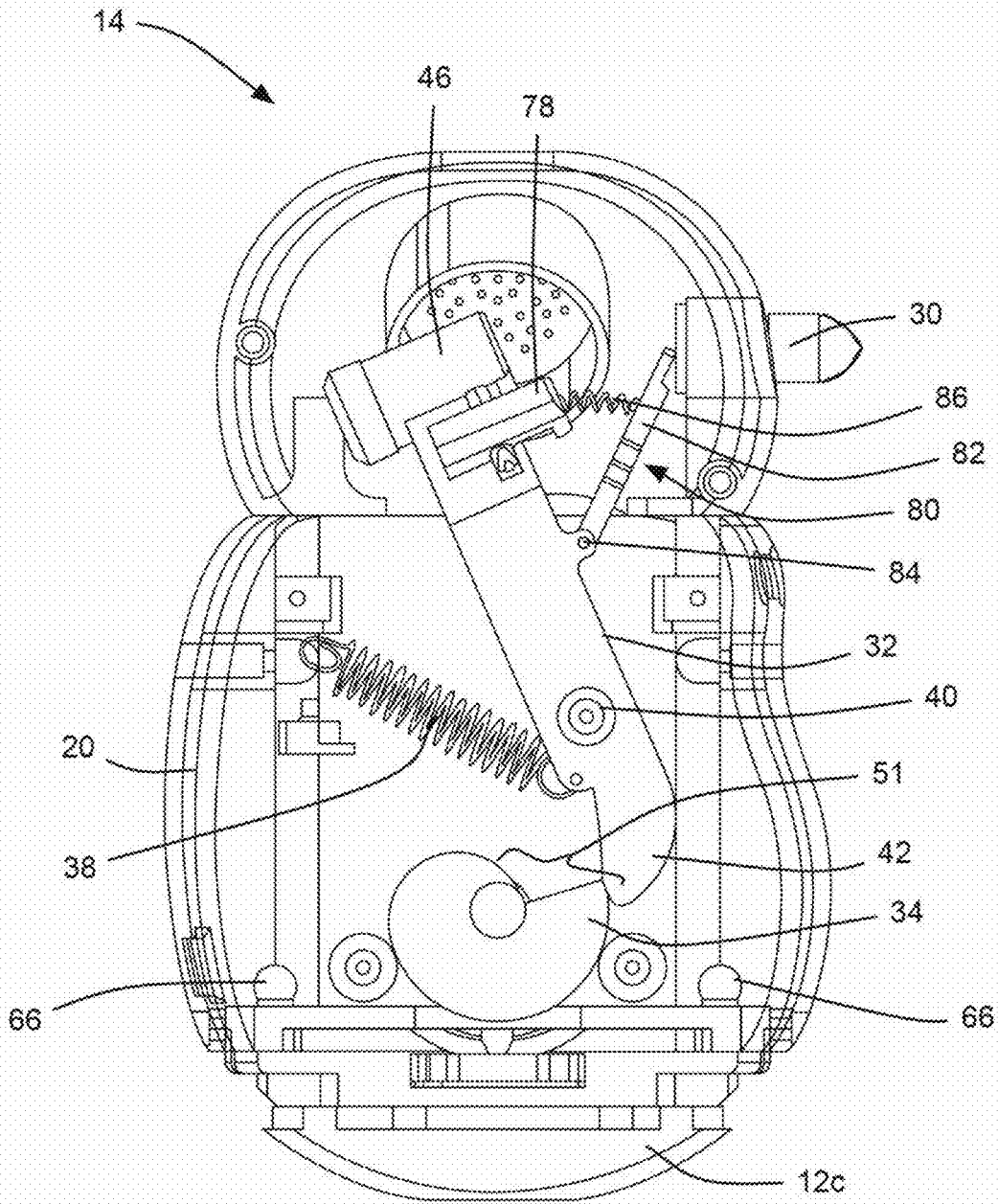

FIG. 7

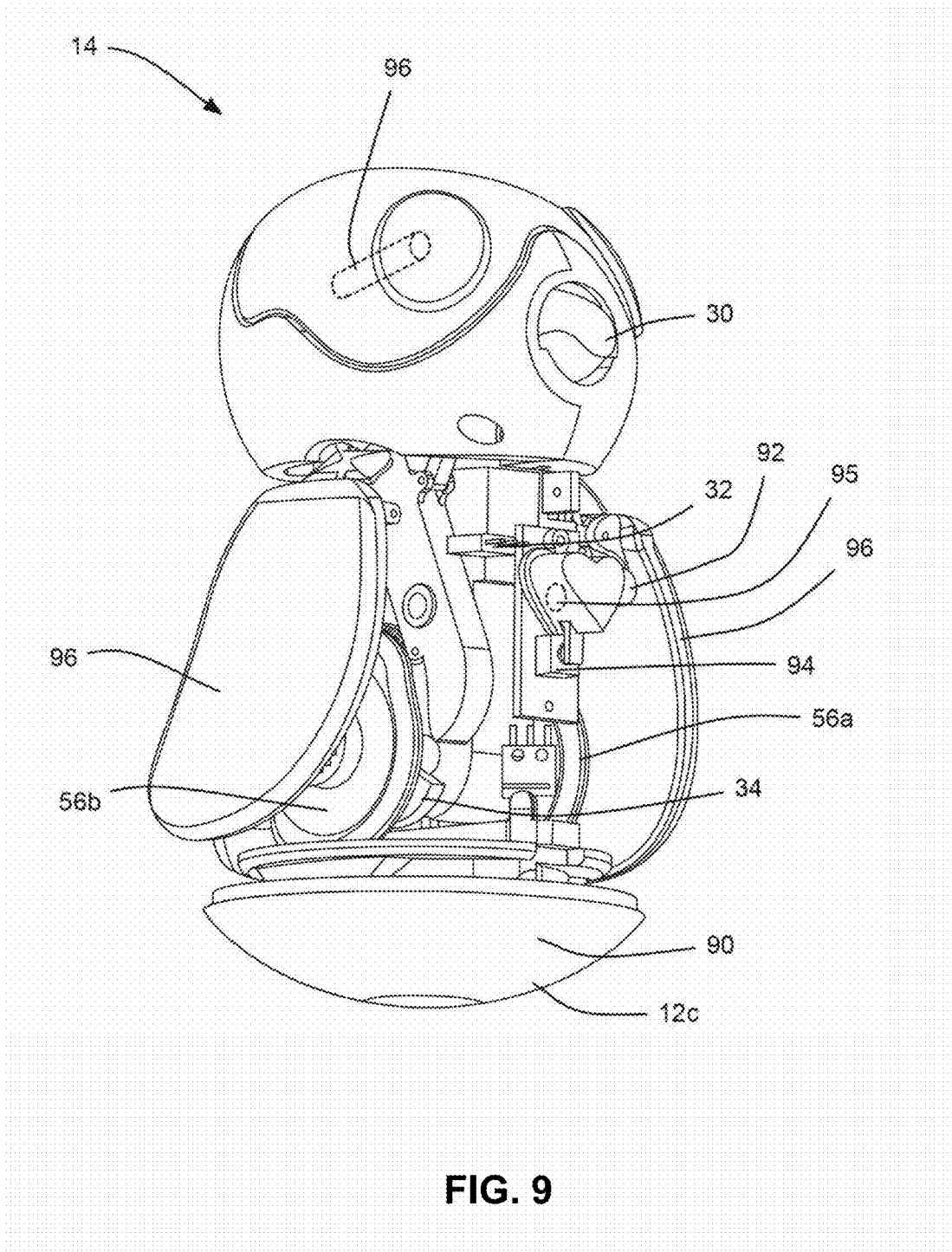

FIG. 9

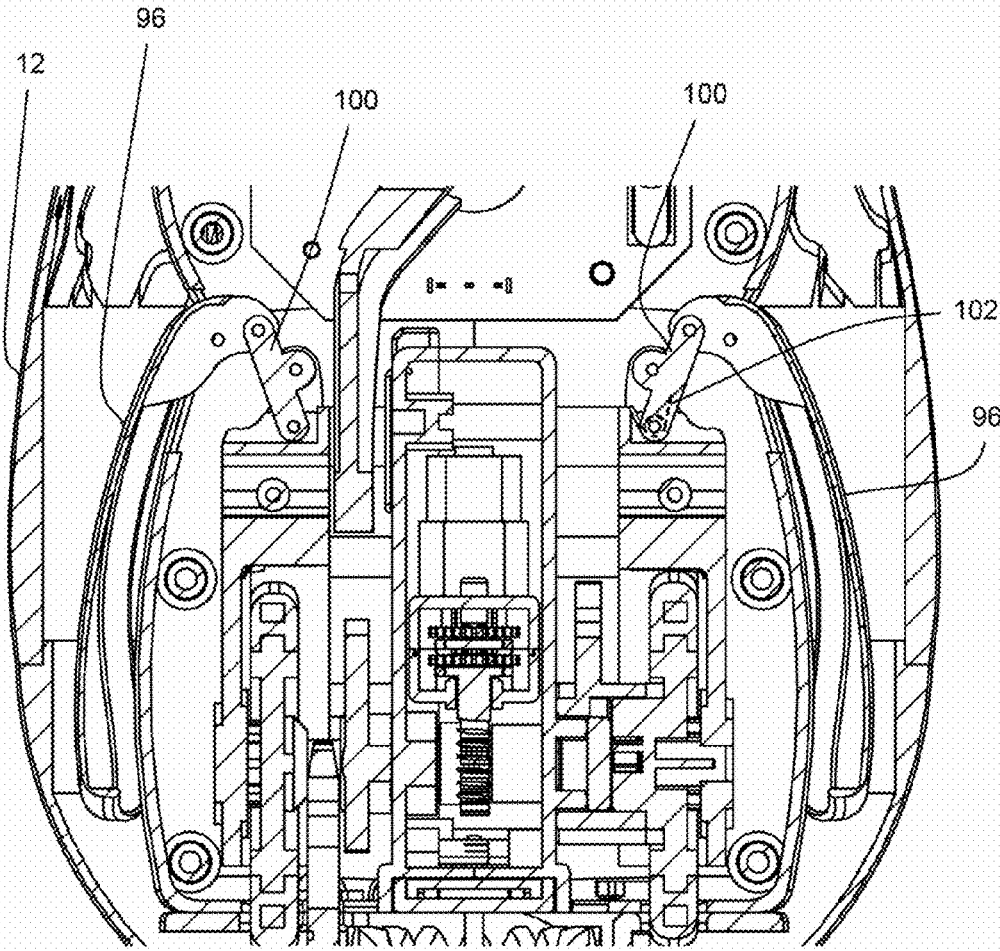

FIG. 10A

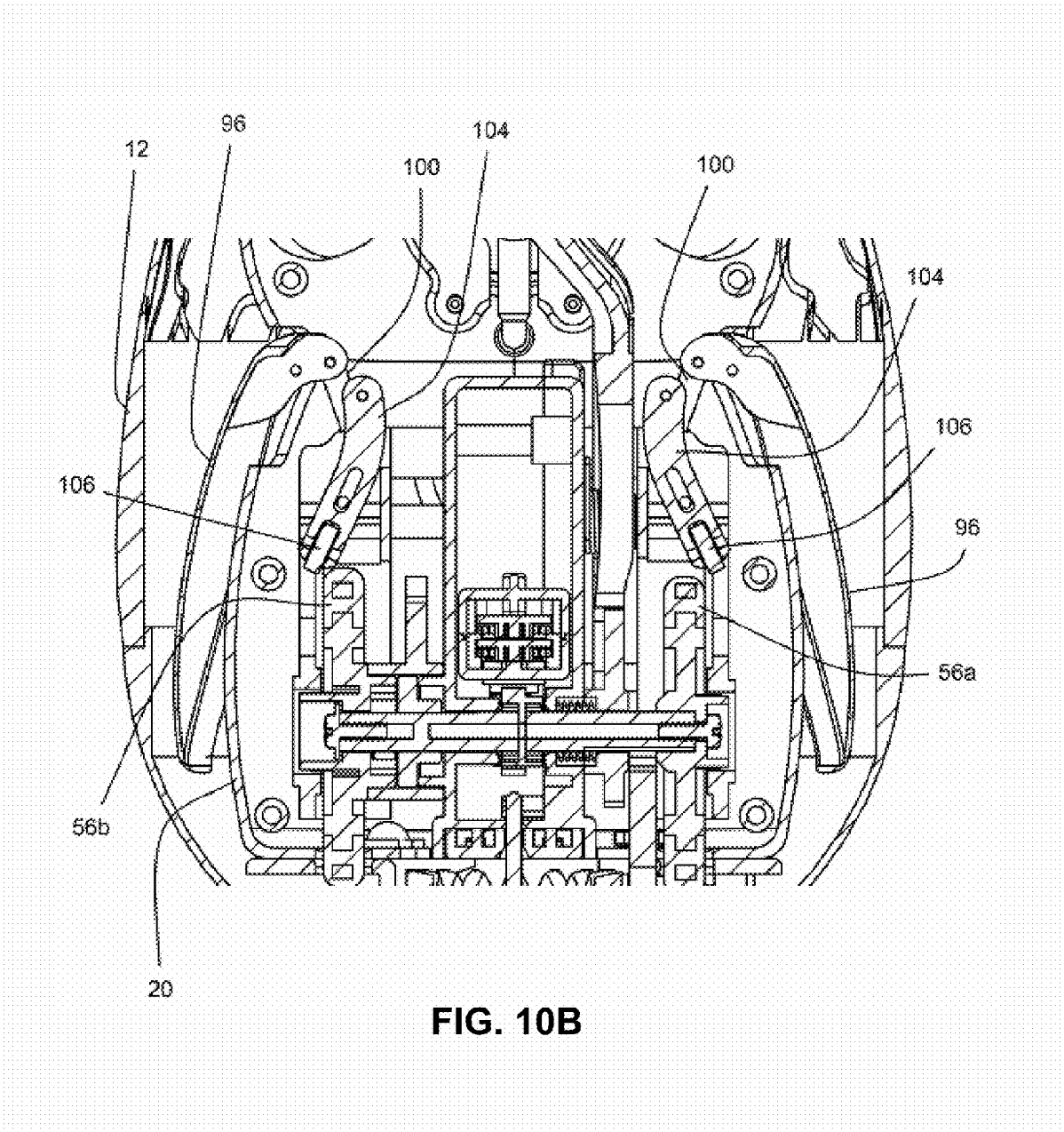

FIG. 10B

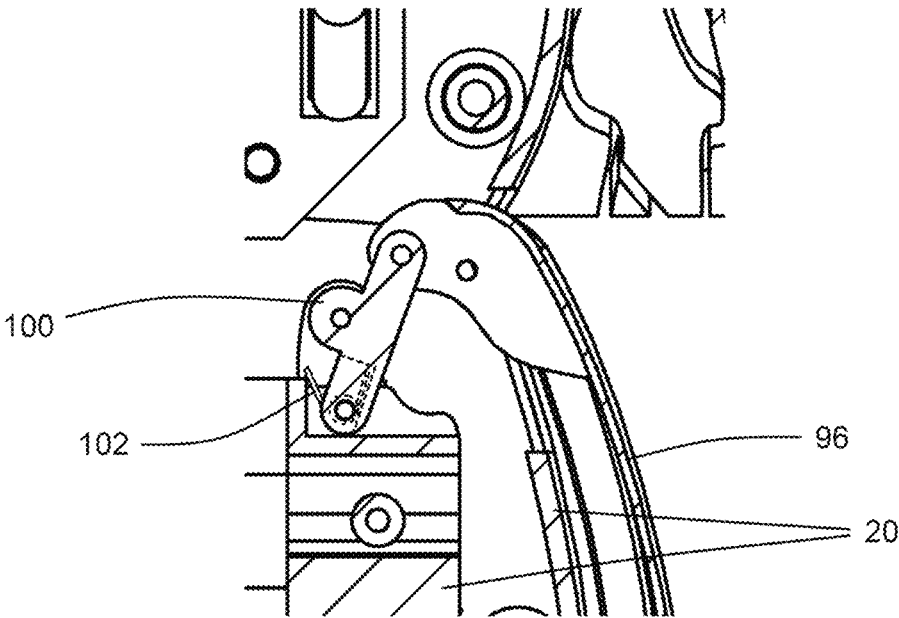

FIG. 10C

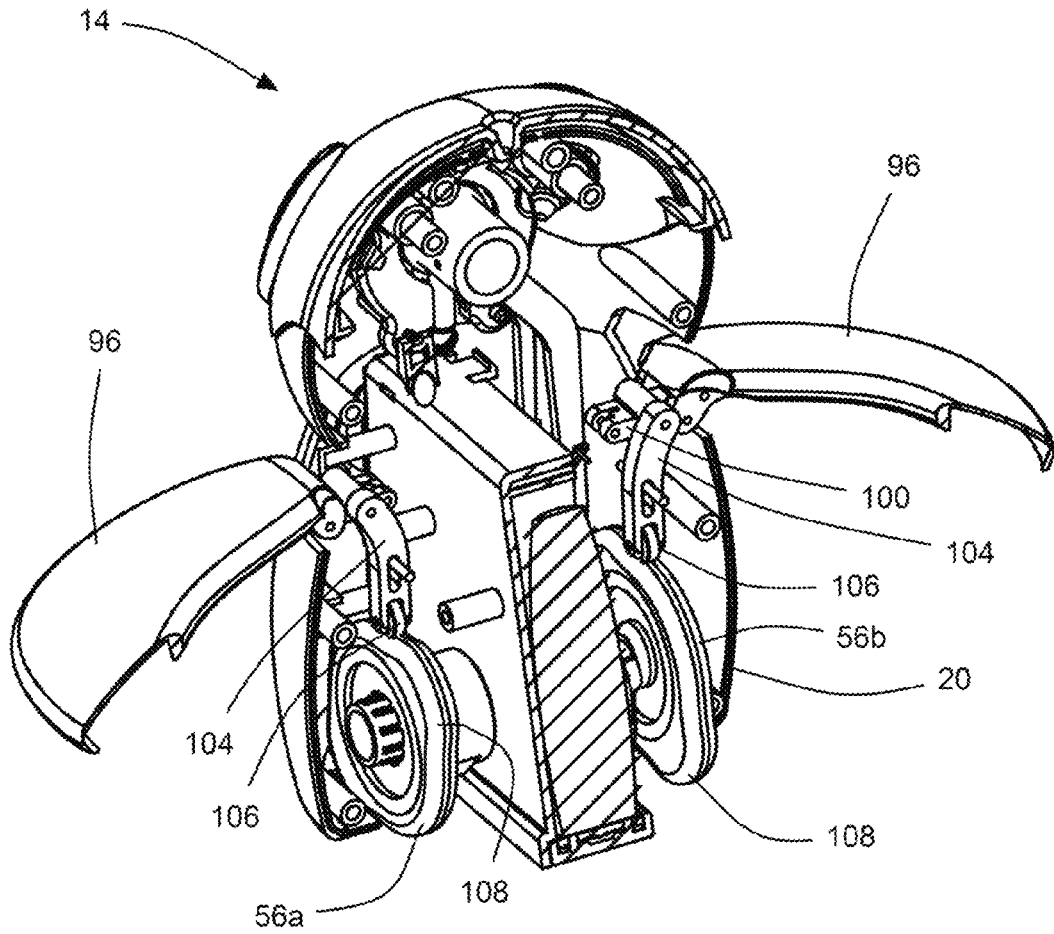

FIG. 10D

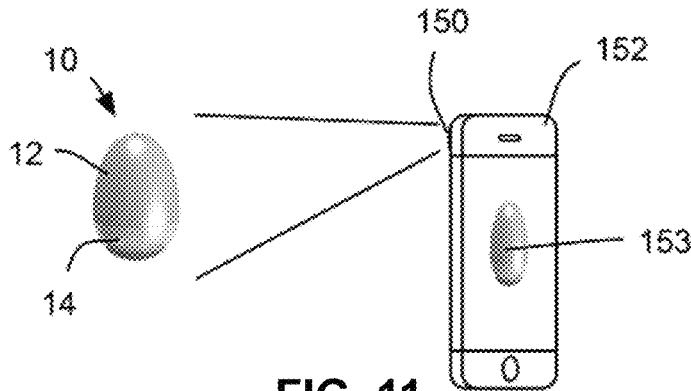

FIG. 11

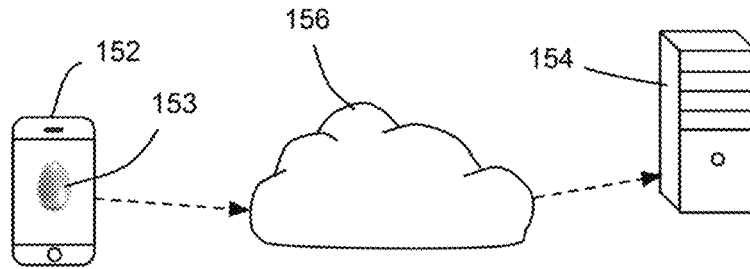

FIG. 12

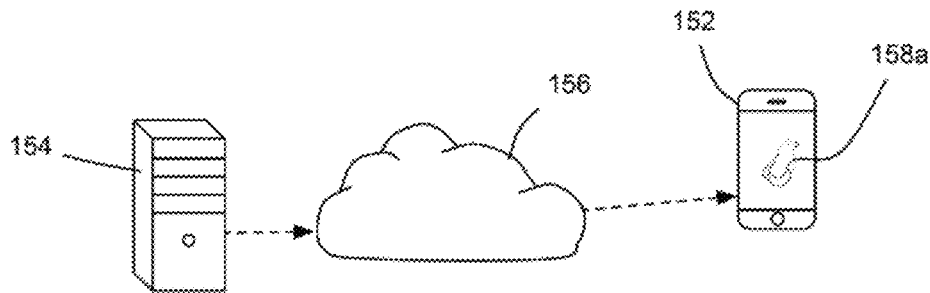

FIG. 13A



FIG. 13B

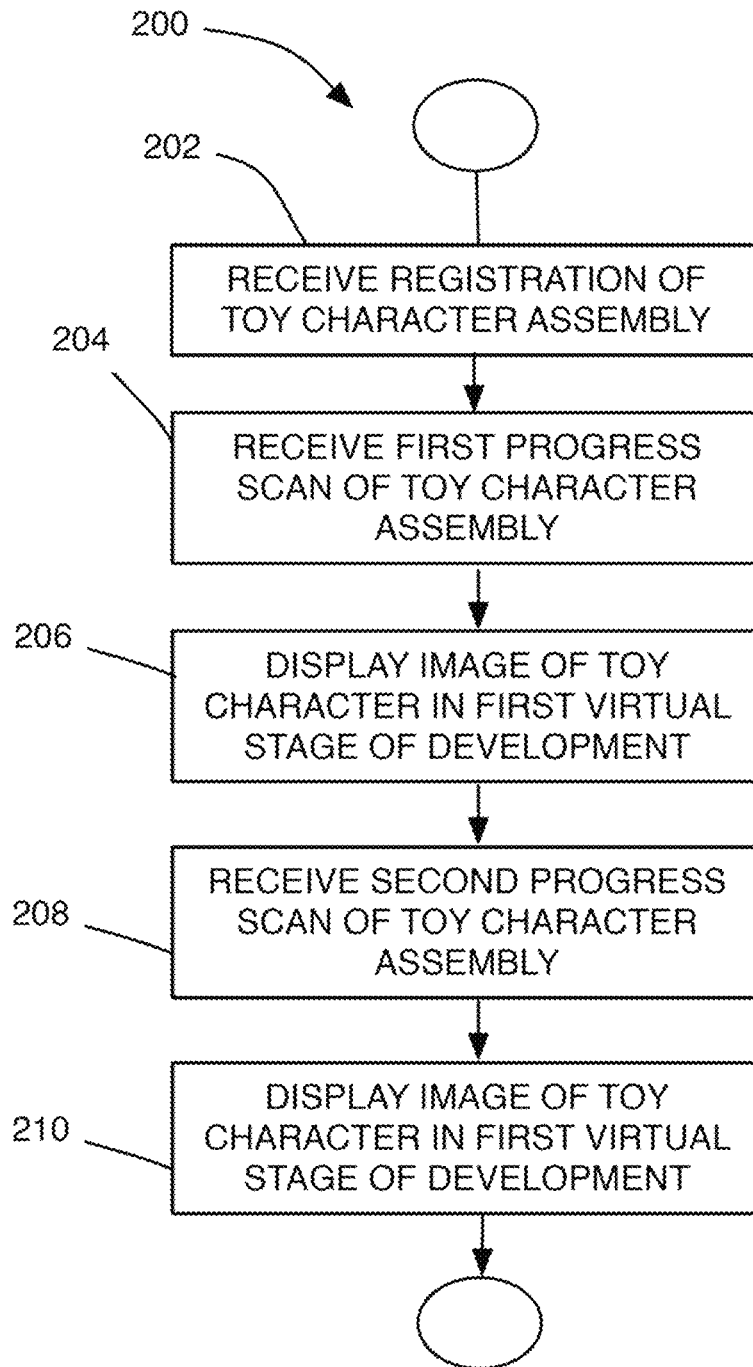

FIG. 14

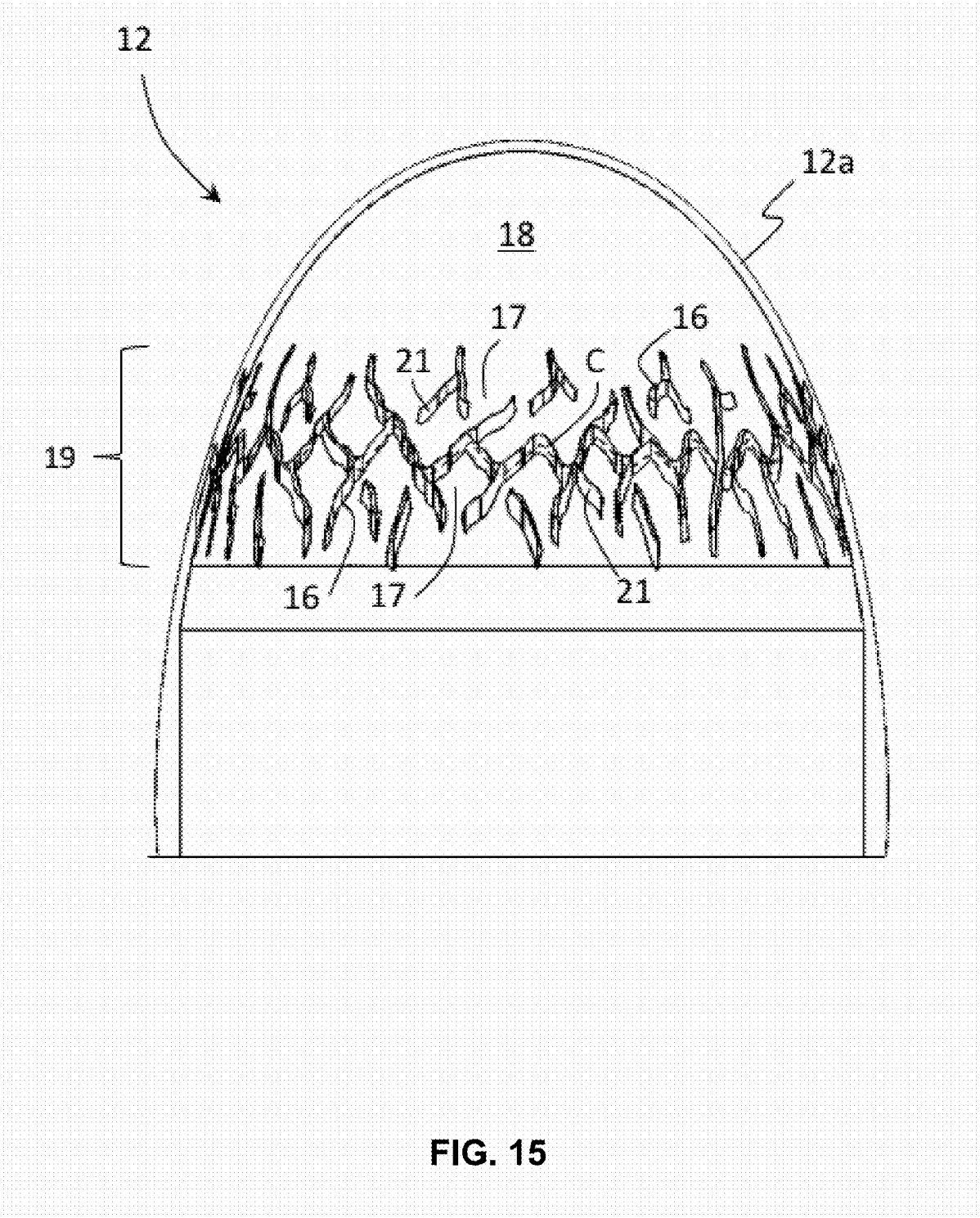

FIG. 15

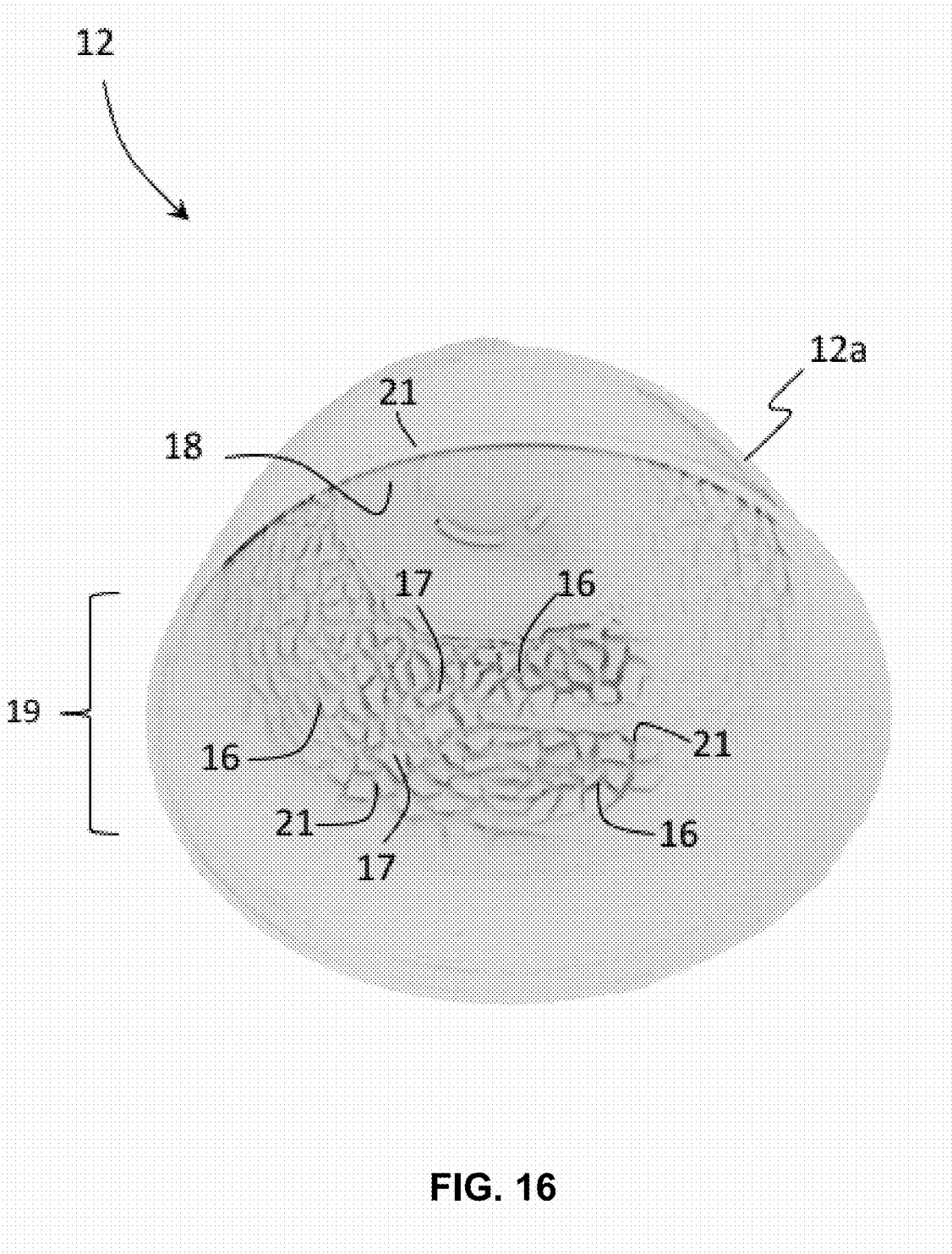

FIG. 16

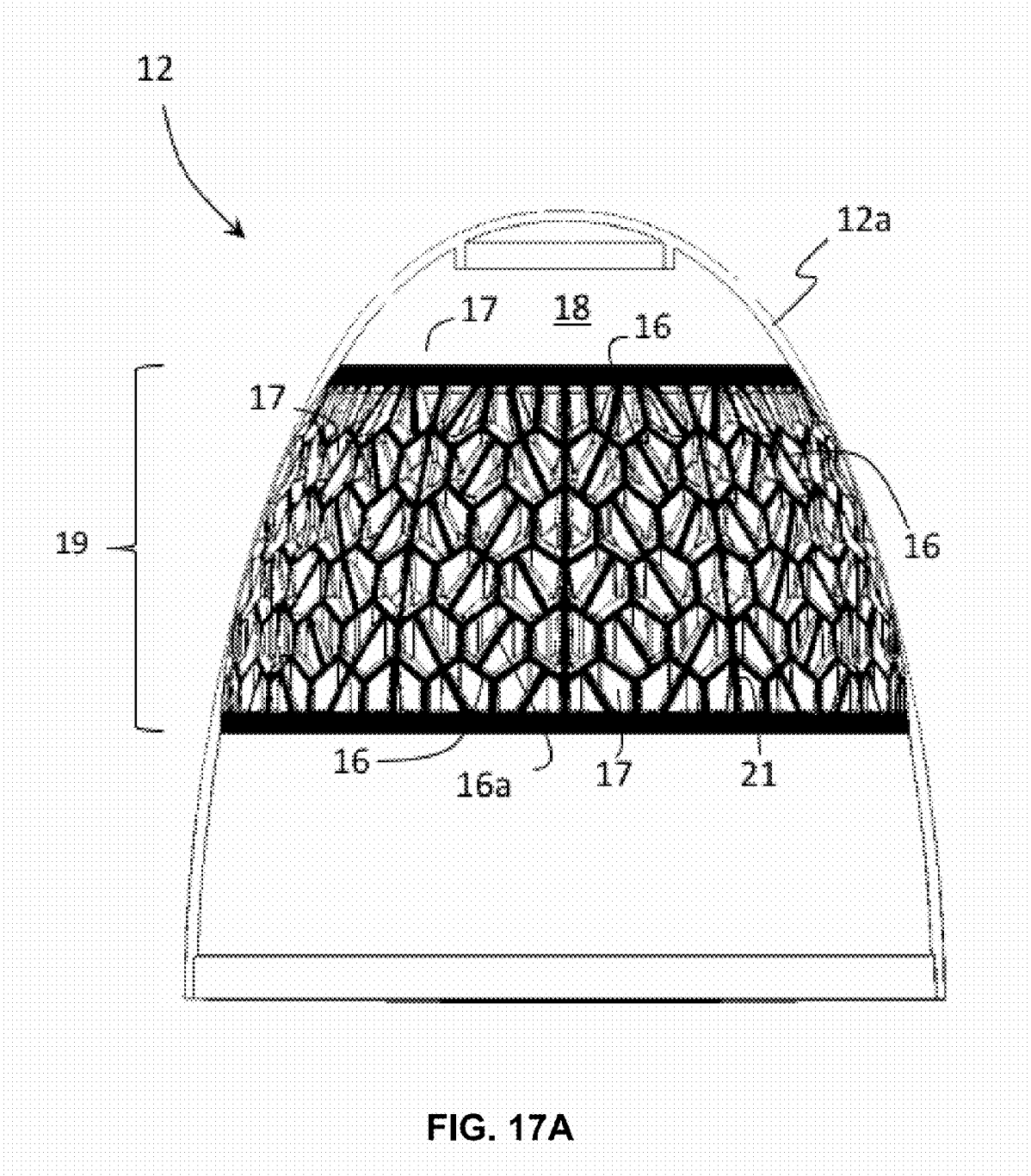
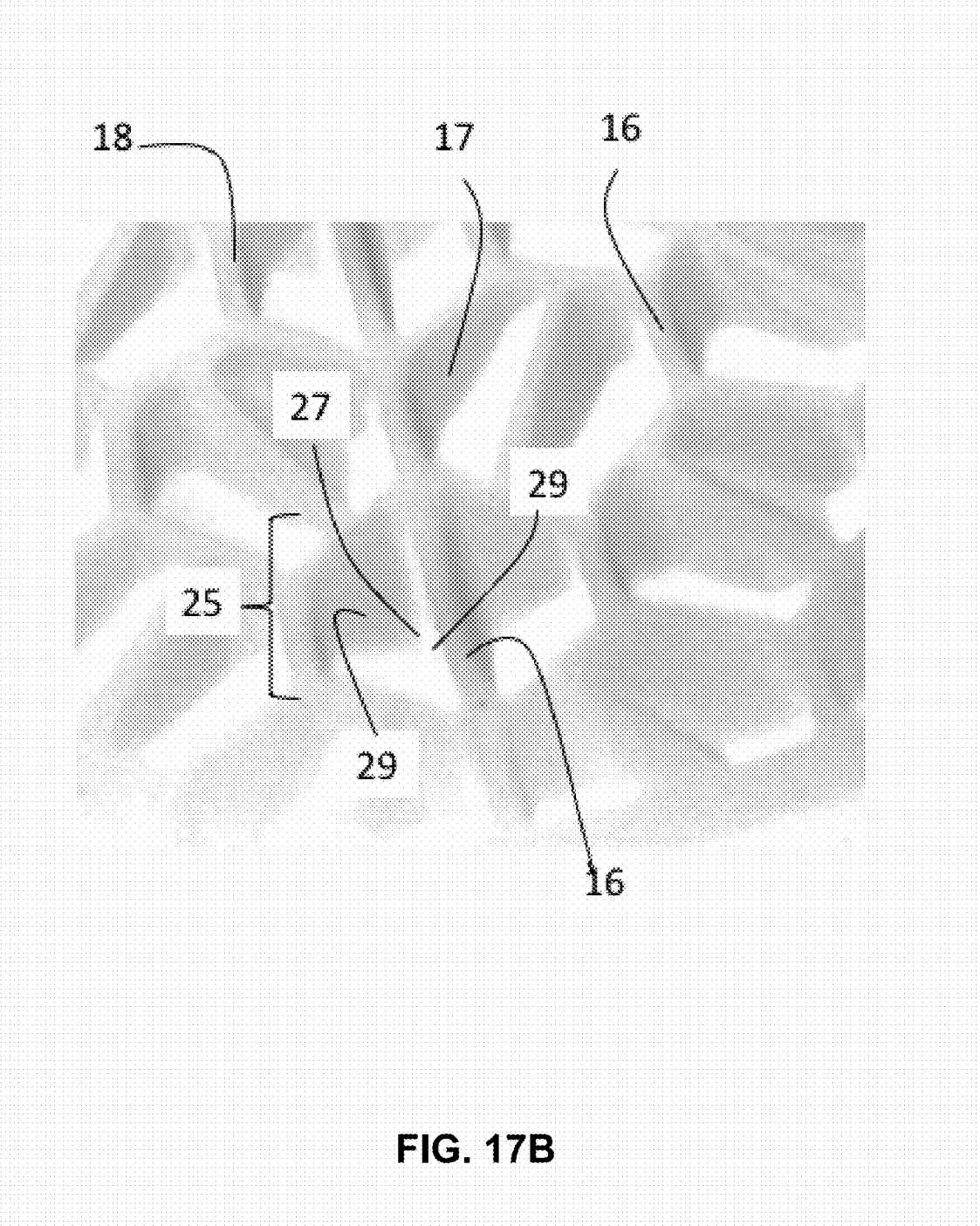

FIG. 17A



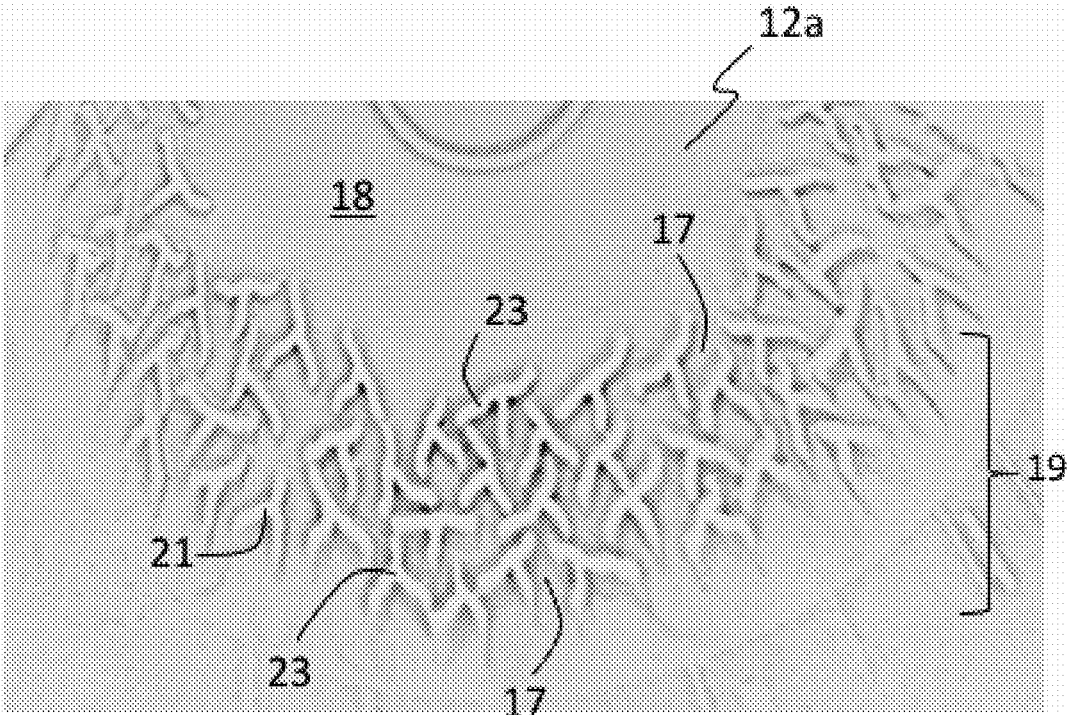

FIG. 18

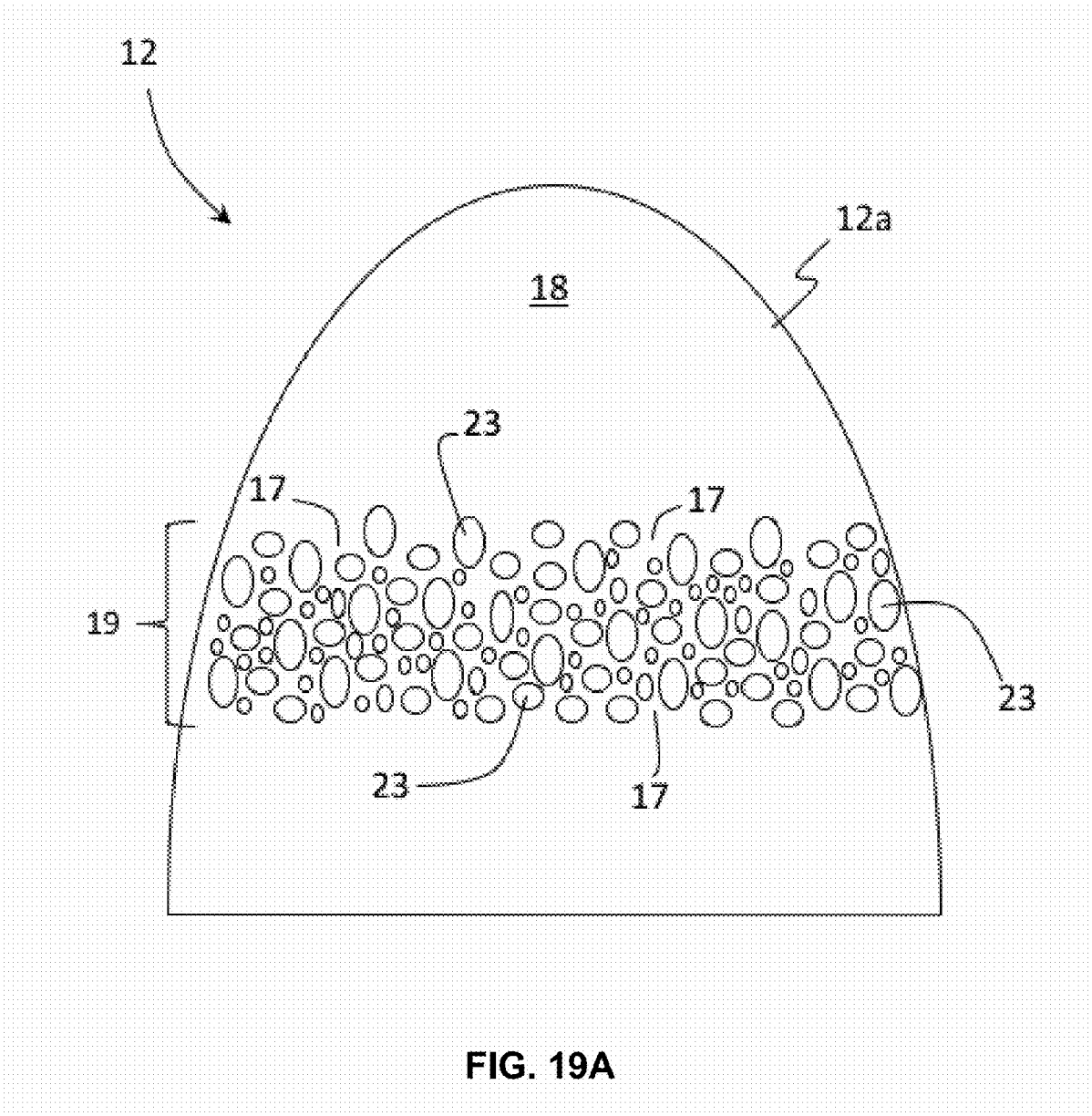

FIG. 19A

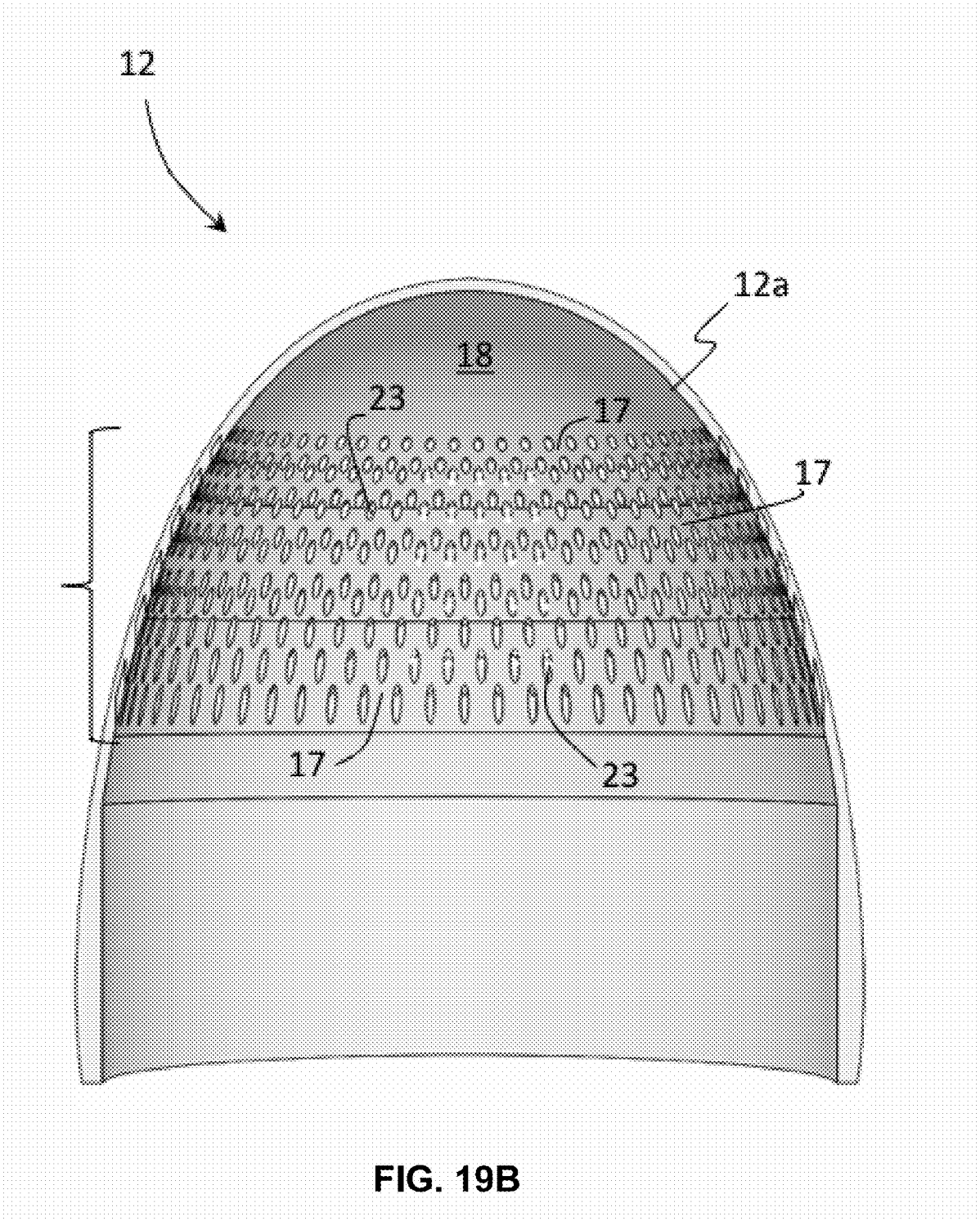

FIG. 19B

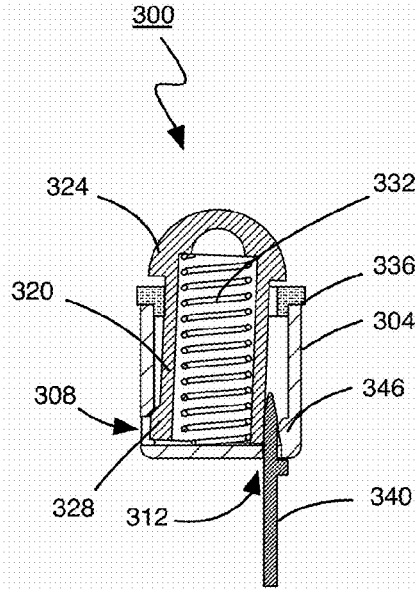
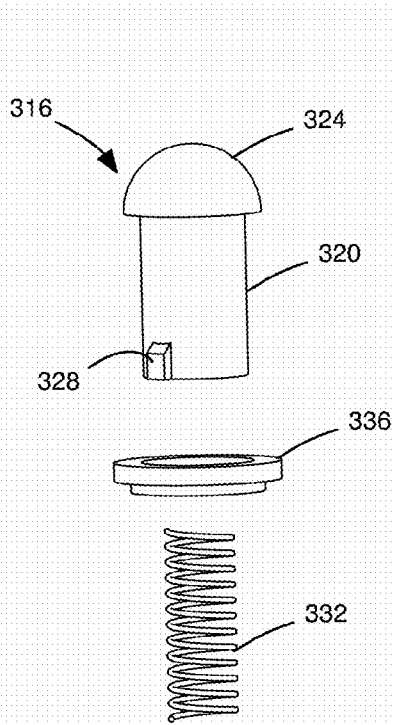

FIG. 21

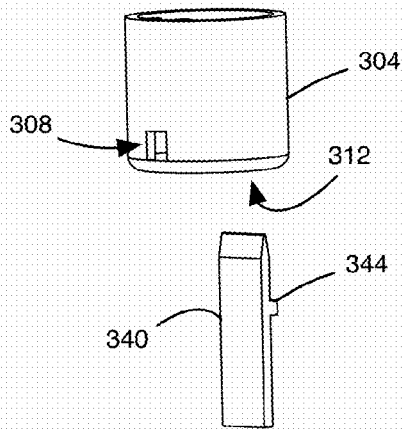

FIG. 20

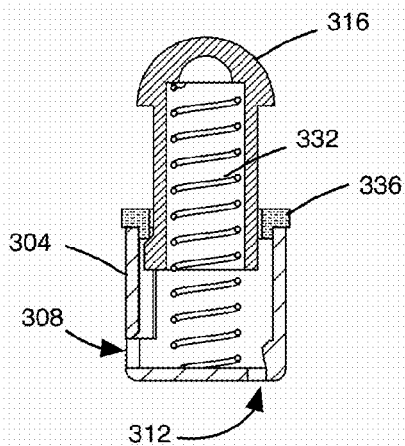

FIG. 22

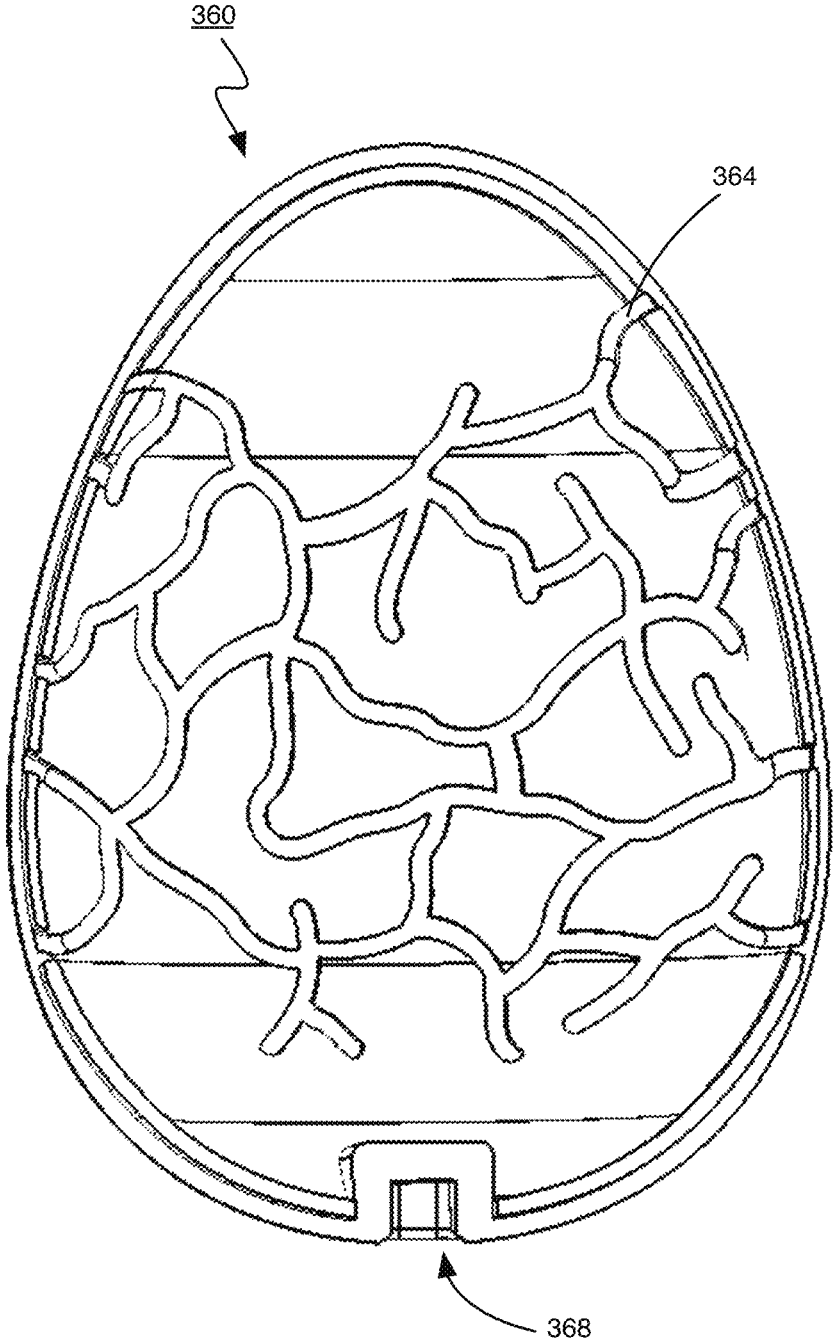

FIG. 23

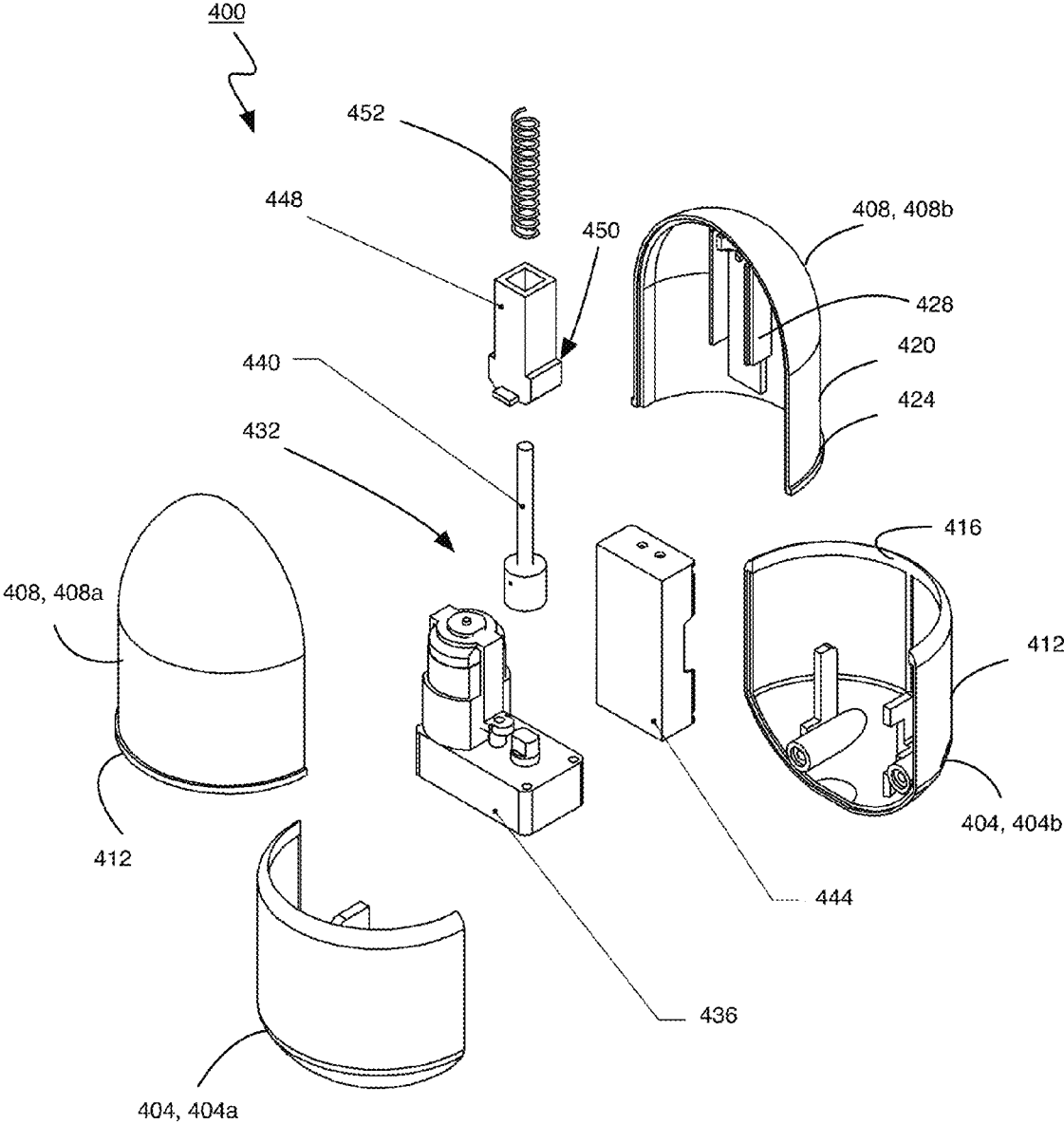

FIG. 24

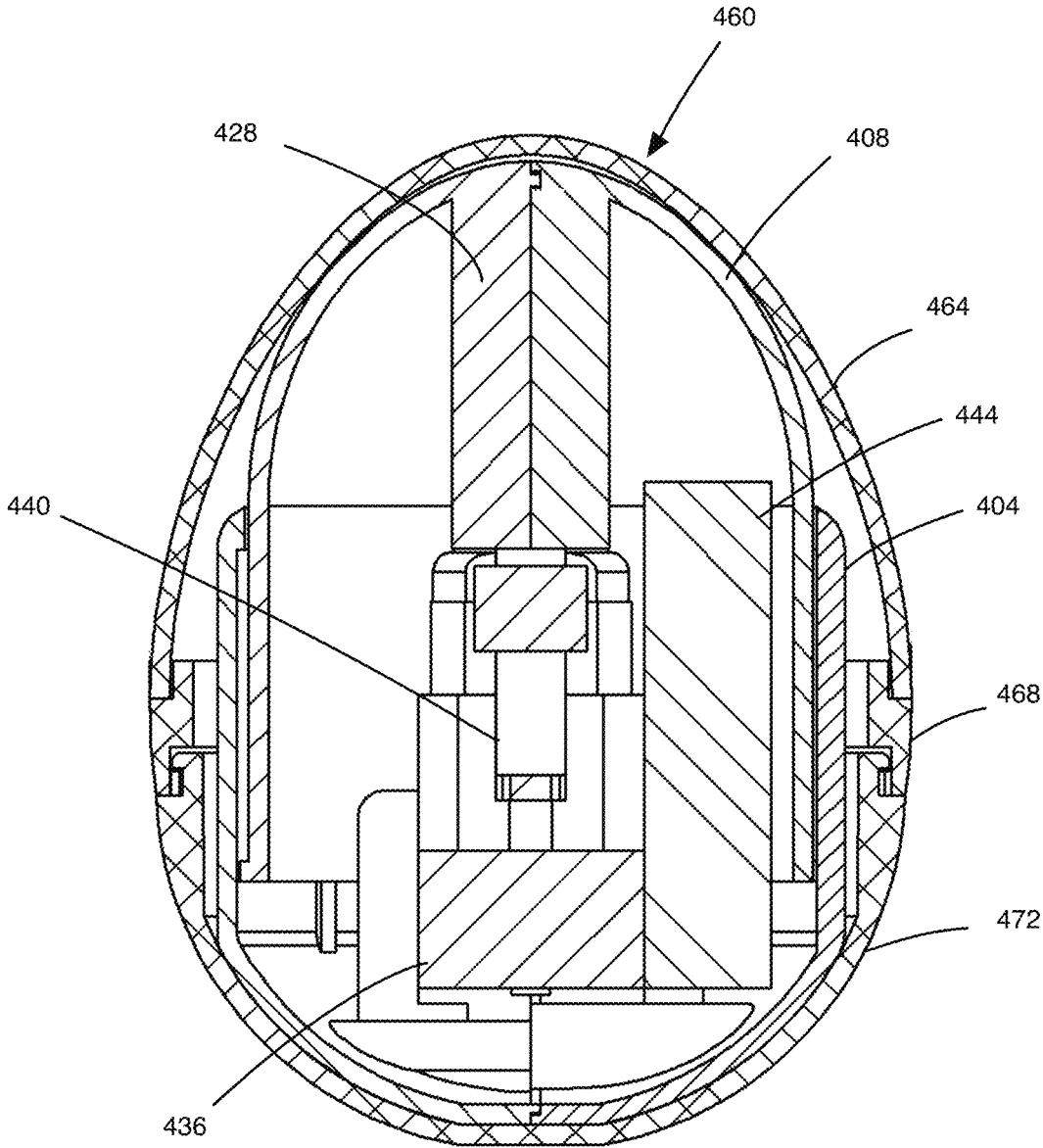

FIG. 25

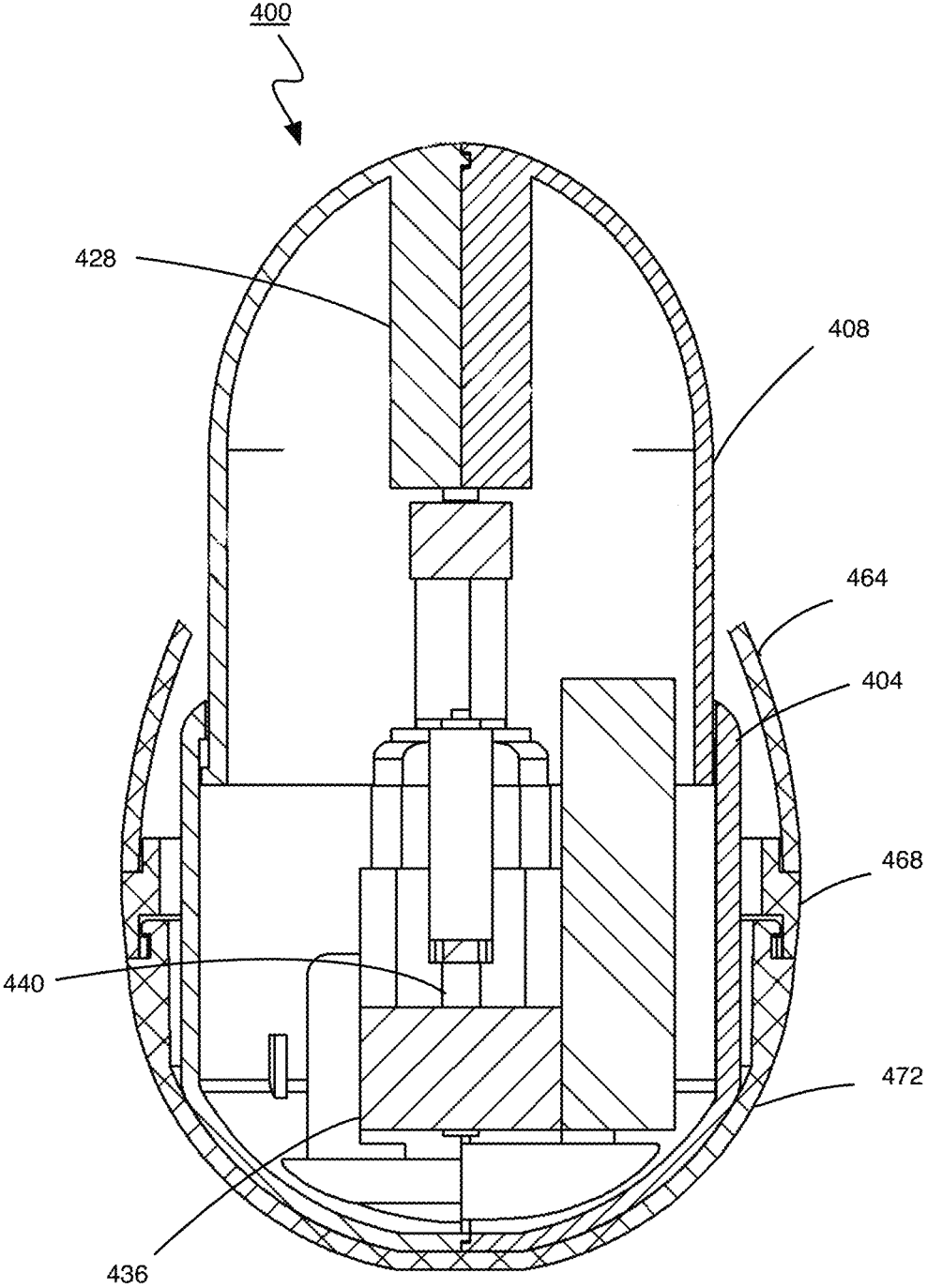

FIG. 26

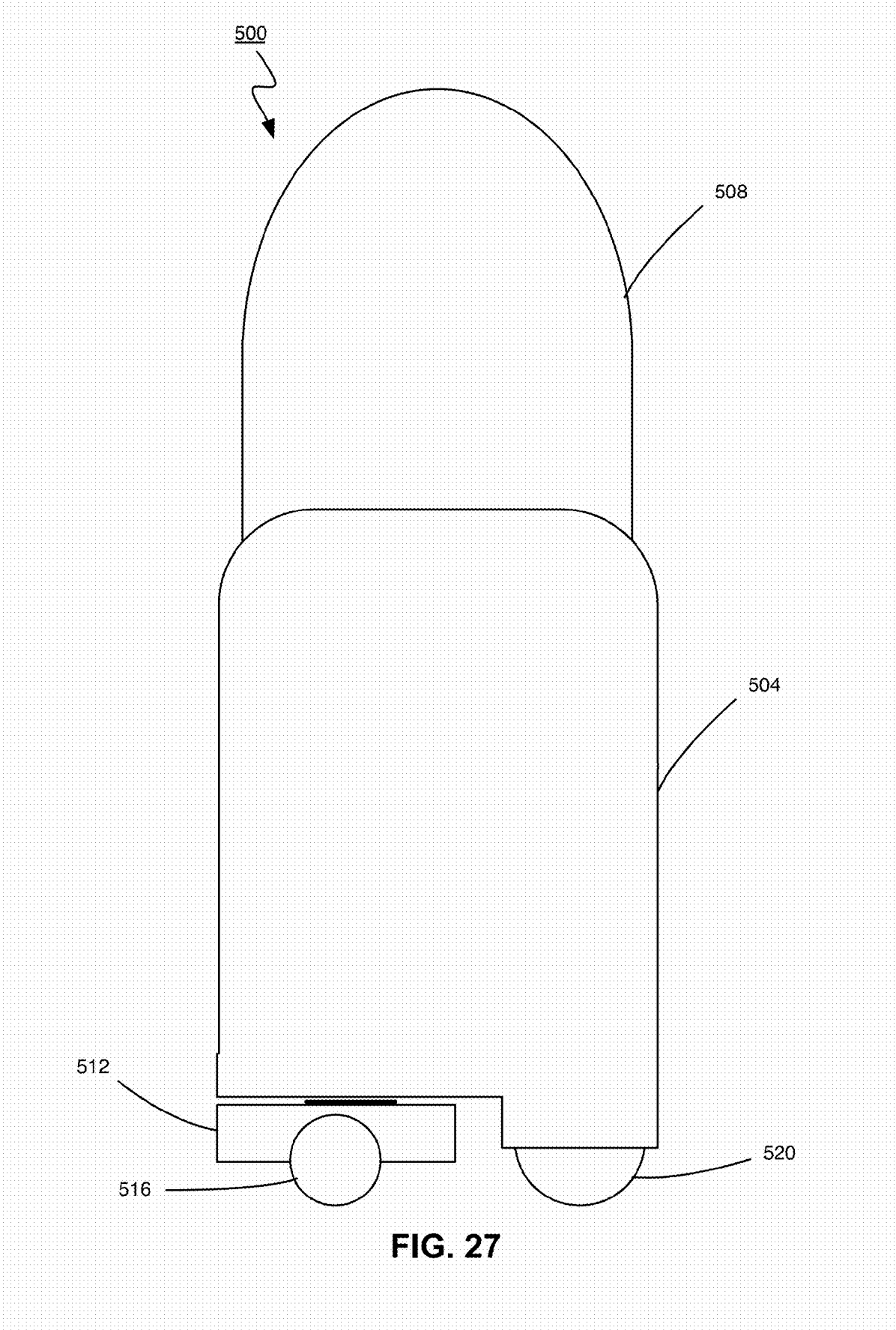

FIG. 27

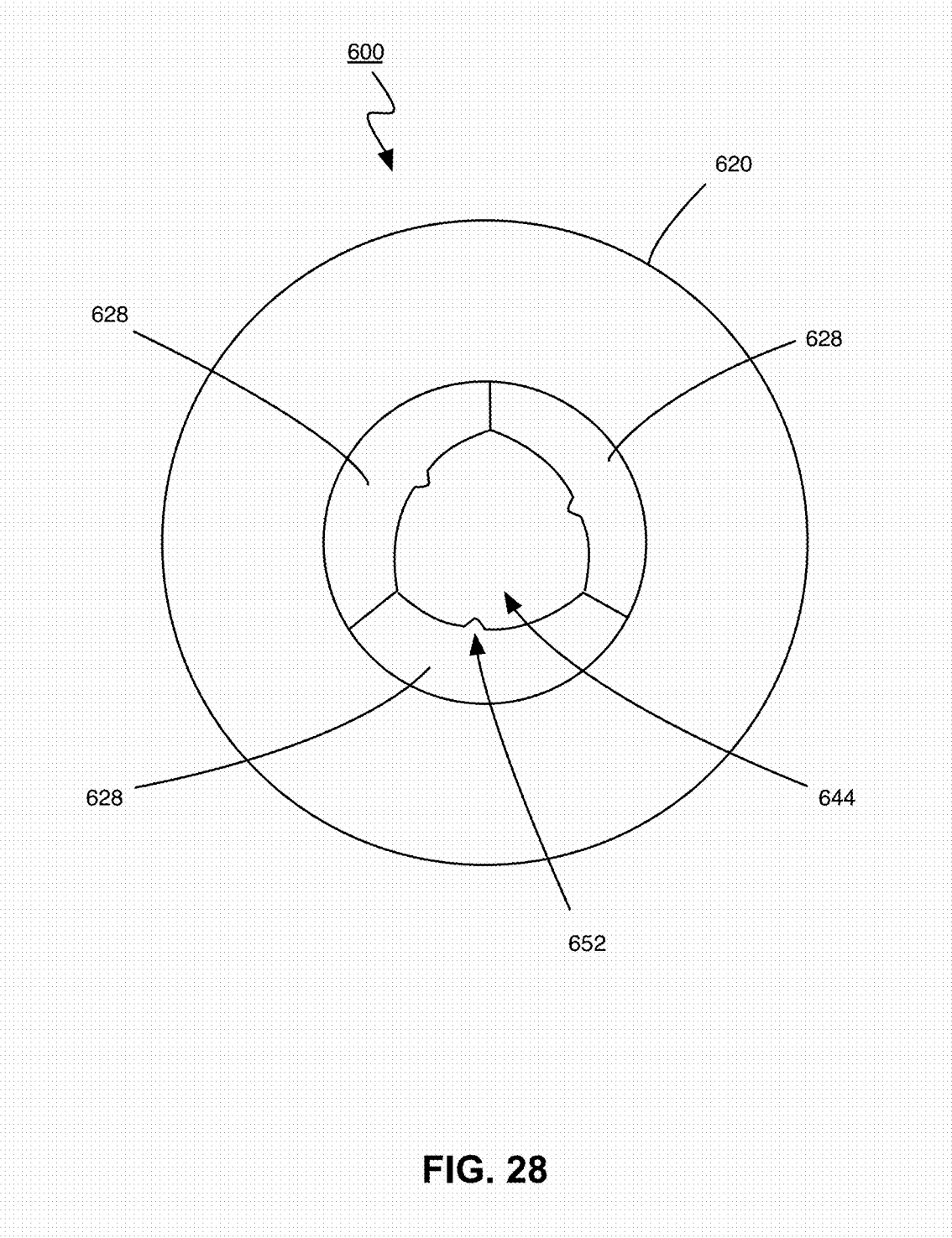

FIG. 28

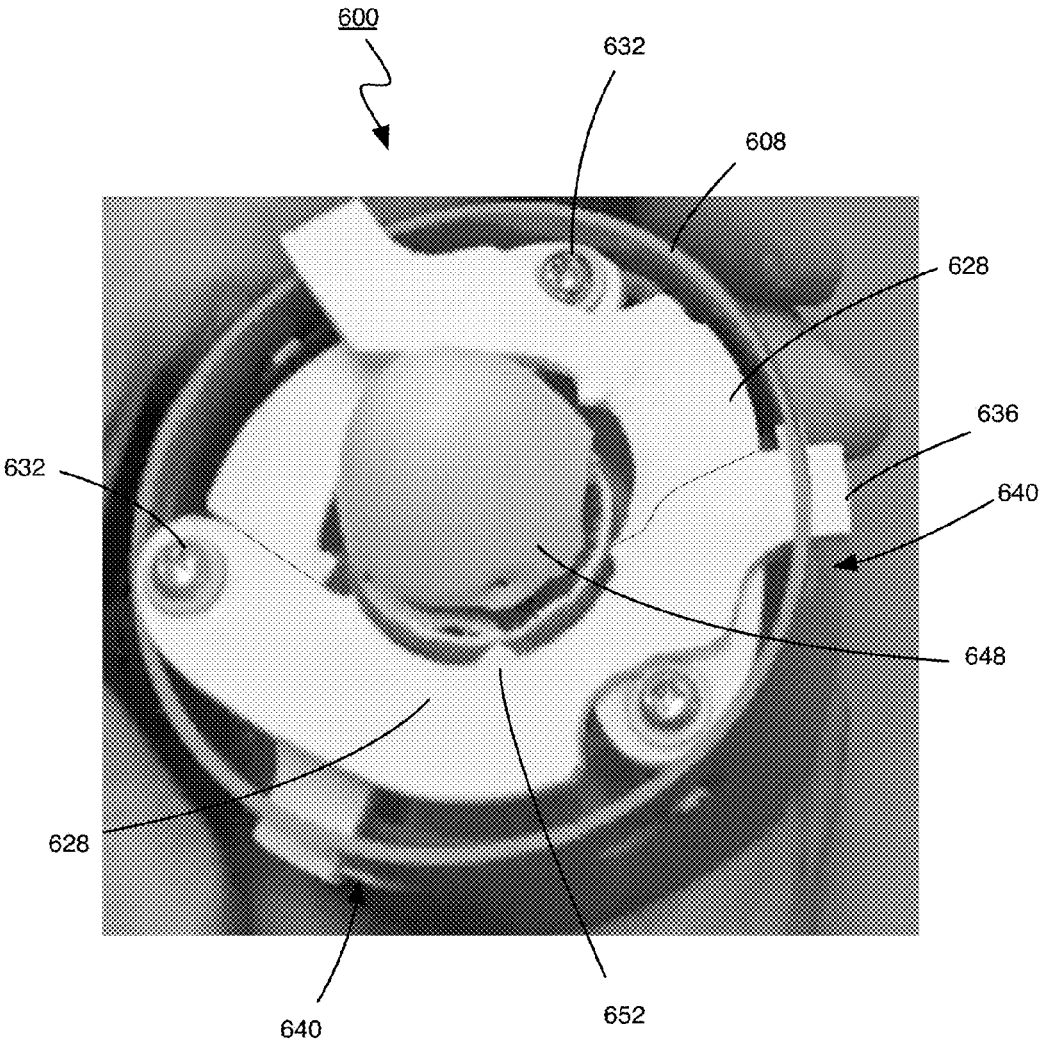

FIG. 29

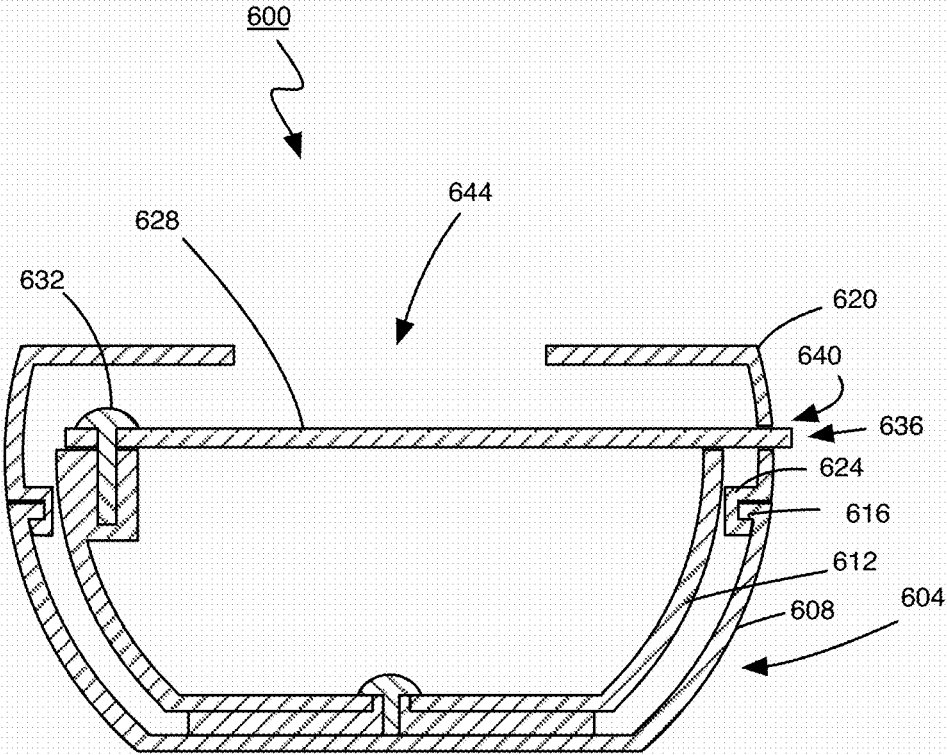

FIG. 30

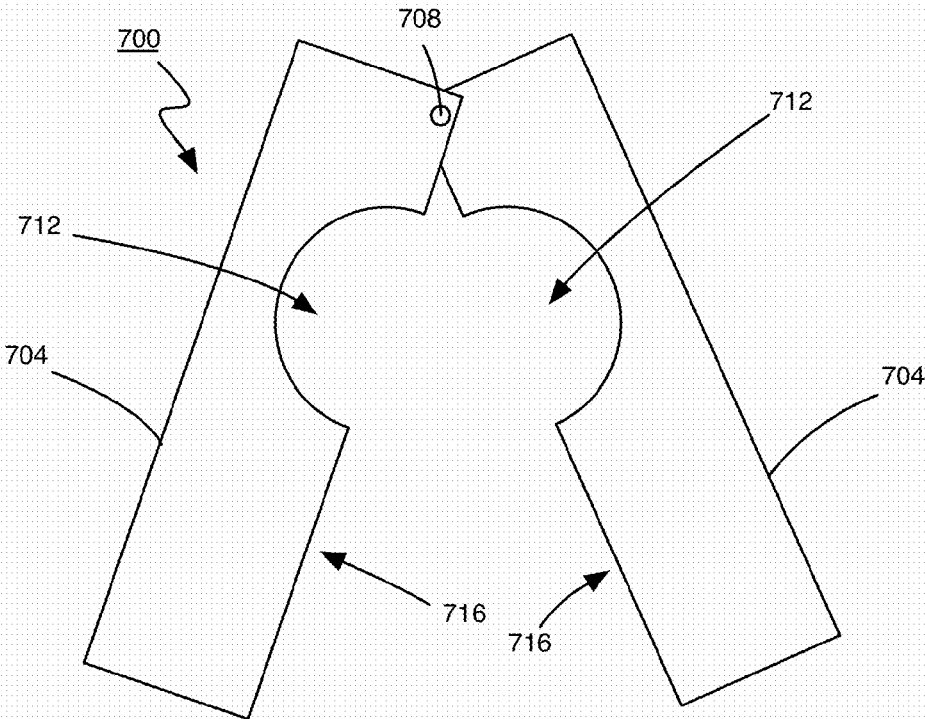

FIG. 31A

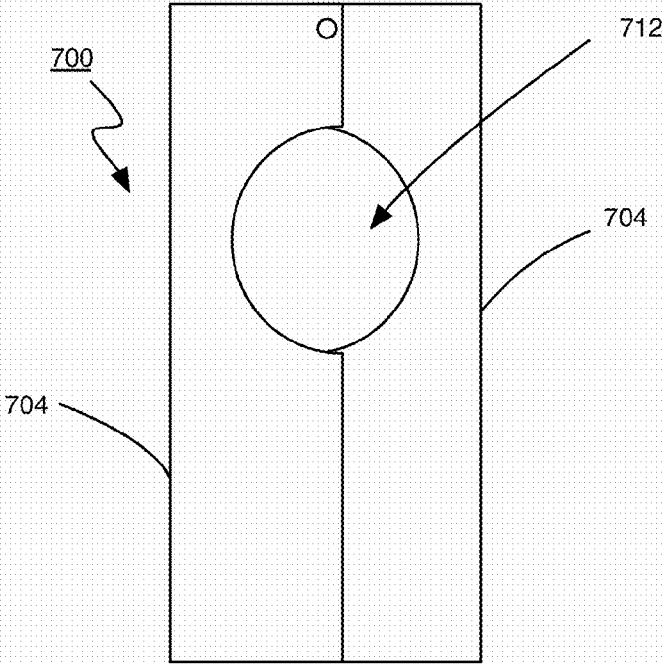

FIG. 31B

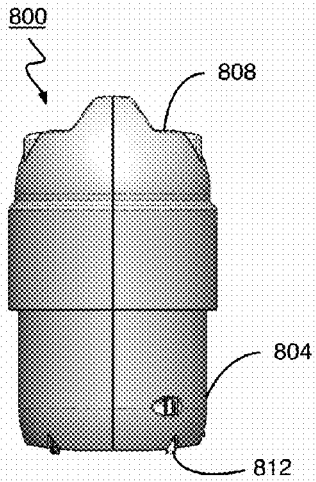

FIG. 32a

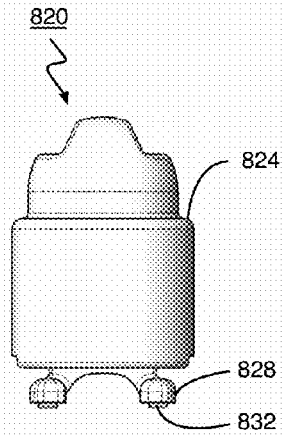

FIG. 32b

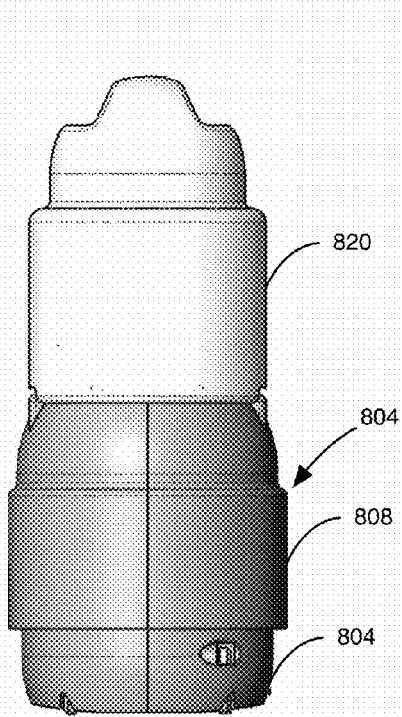

FIG. 33

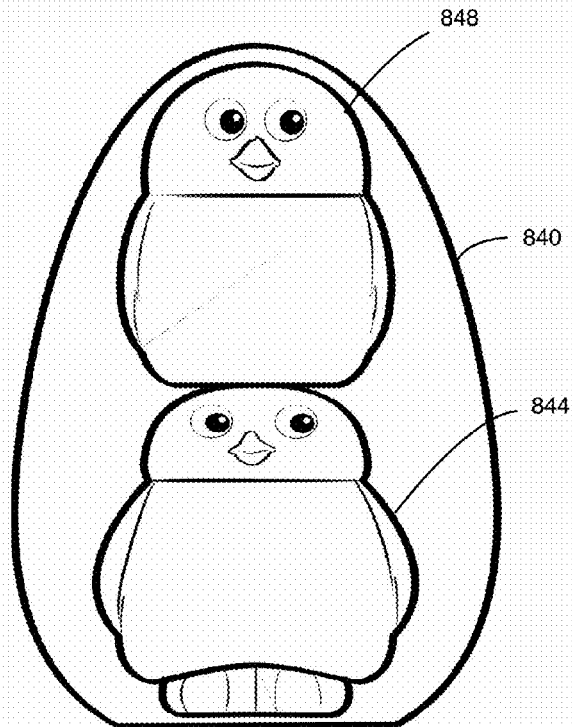

FIG. 34

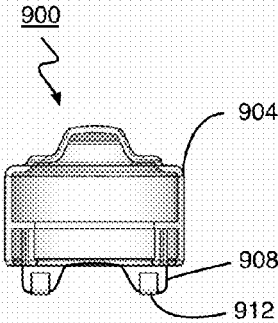

FIG. 35

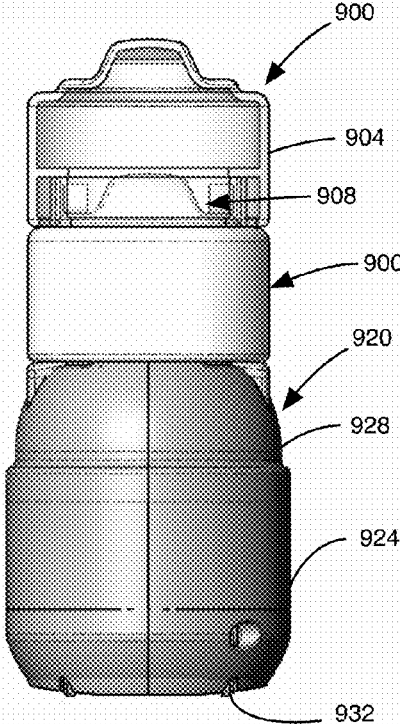

FIG. 36

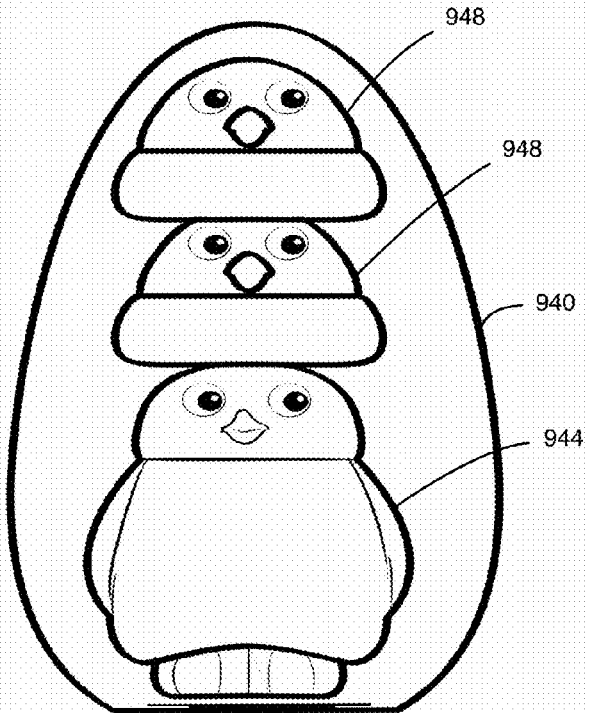

FIG. 37

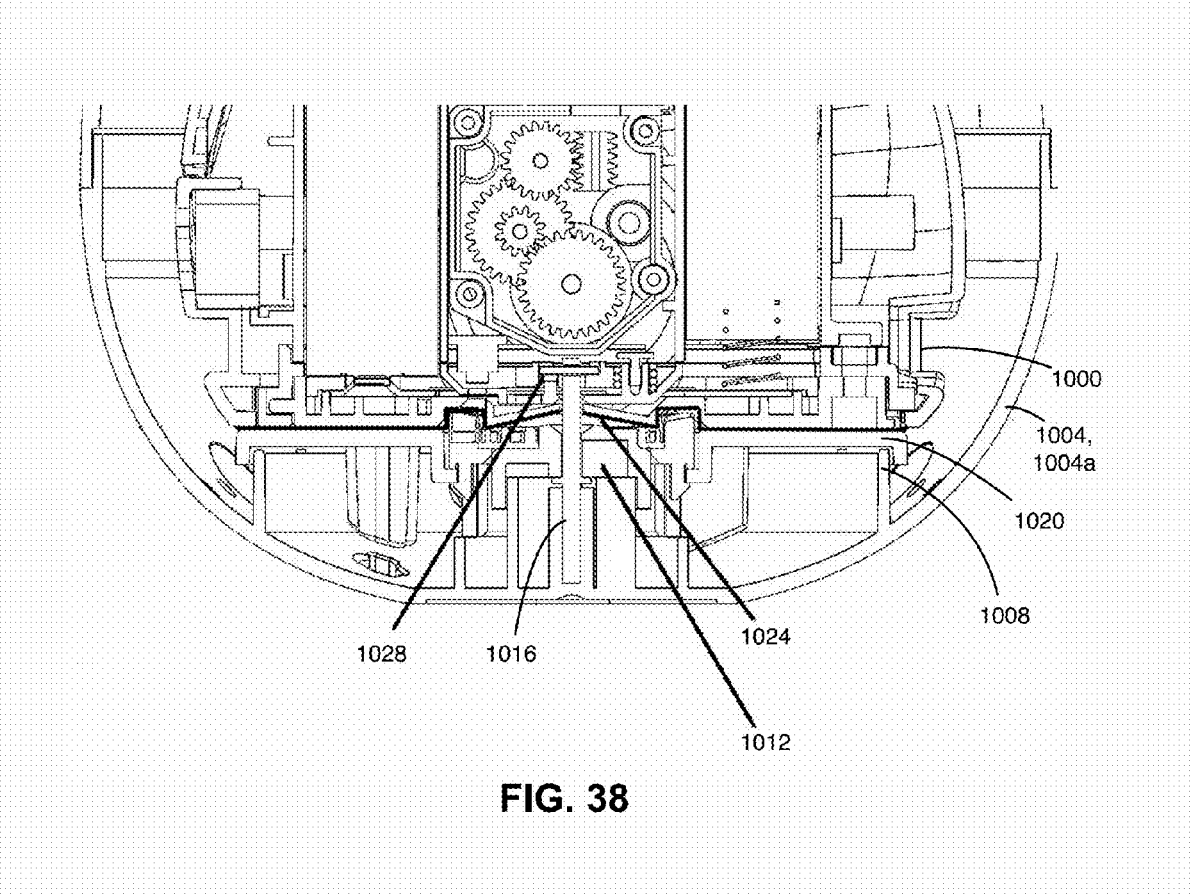

FIG. 38

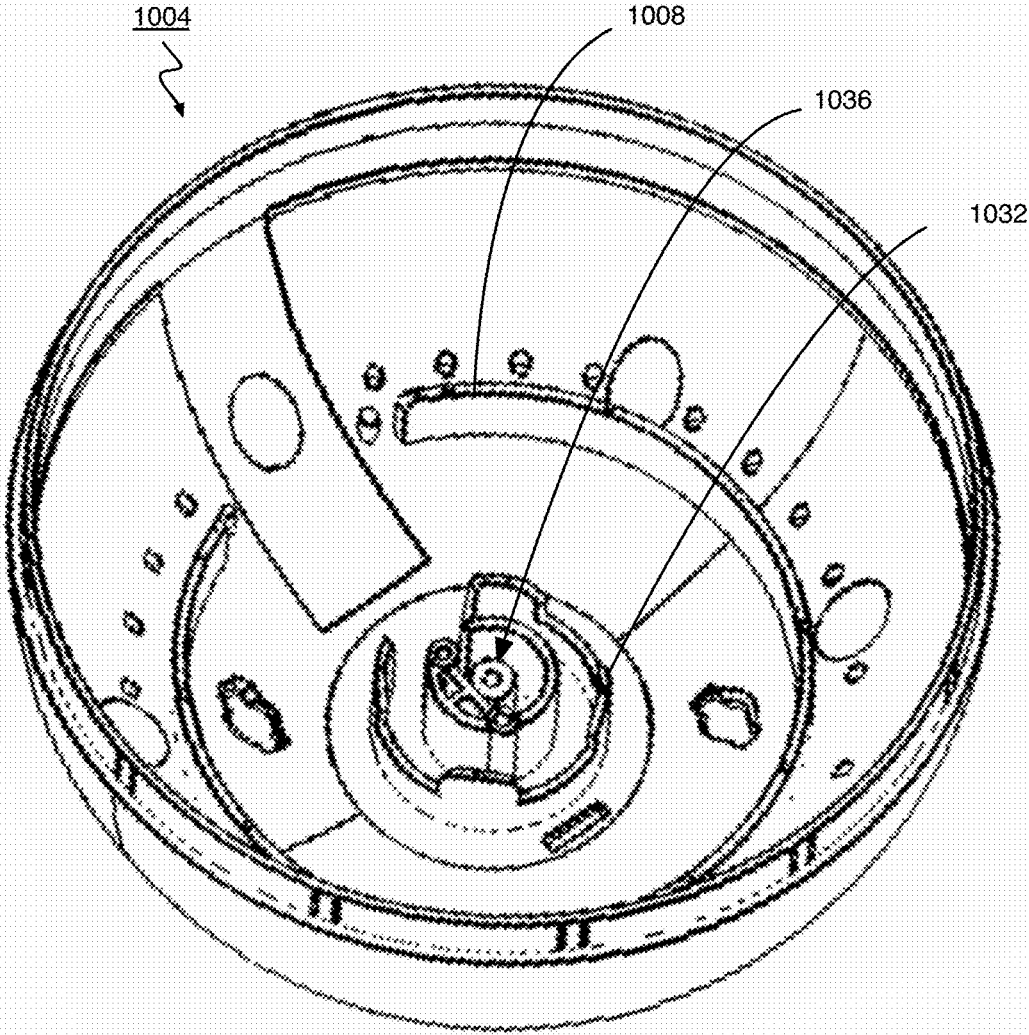

FIG. 39

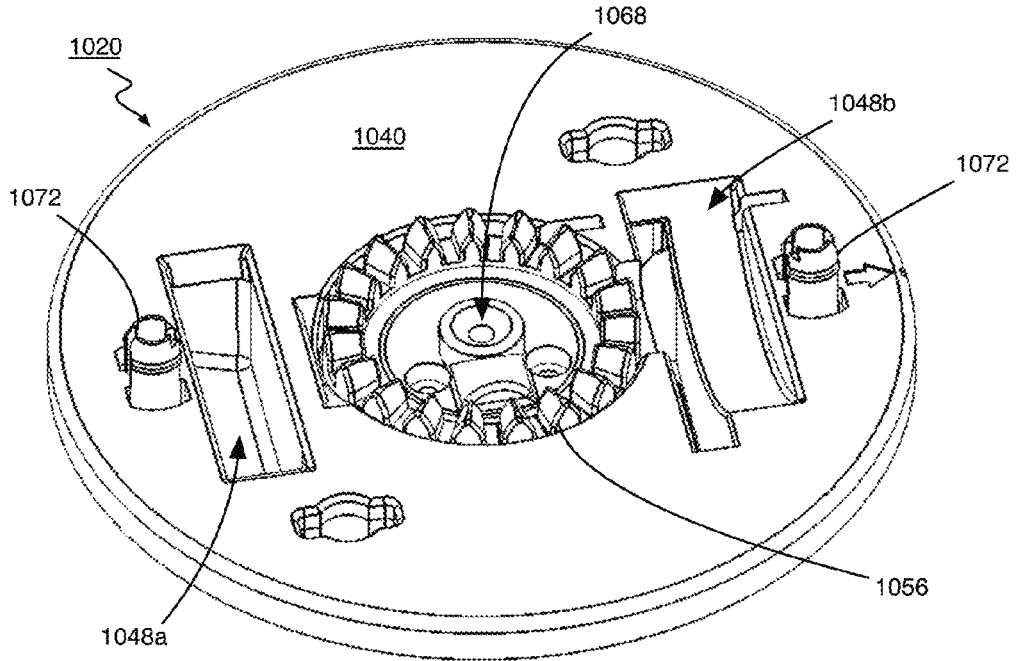

FIG. 40A

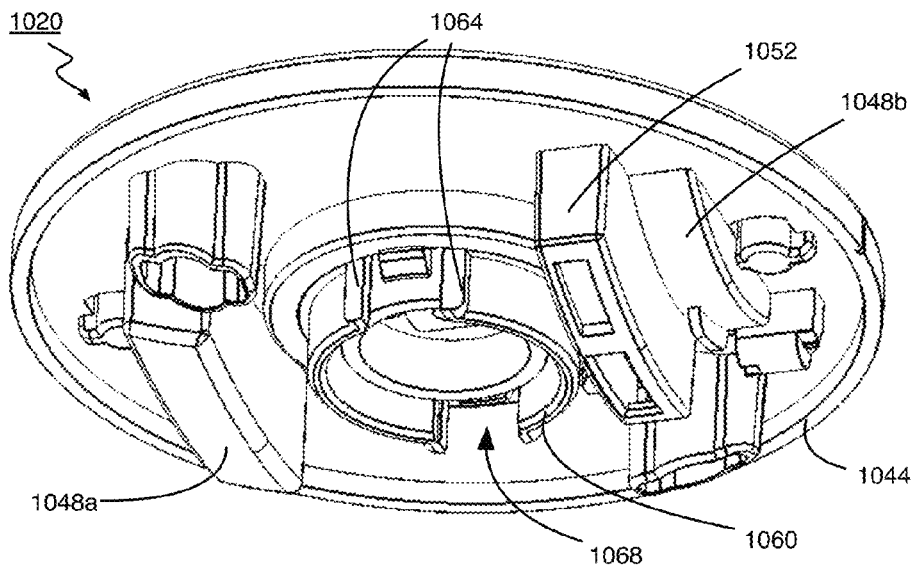

FIG. 40B

1

ASSEMBLY WITH OBJECT IN HOUSING AND MECHANISM TO OPEN HOUSING

CROSS-REFERENCE TO RELATED APPLICATIONS

This application is a continuation of U.S. application Ser. No. 15/227,740, which is a continuation-in-part application of U.S. application Ser. No. 15/199,341 filed Jun. 30, 2016, which is a continuation-in-part application of U.S. application Ser. No. 14/884,191 filed Oct. 15, 2015, the content of all of which are incorporated herein by reference in their entirety.

FIELD

The specification relates generally to assemblies with inner objects inside housings, and more particularly to a toy character in a housing shaped like an egg.

BACKGROUND OF THE DISCLOSURE

There is a continuing desire to provide toys that interact with a user, and for the toys to reward the user based on the interaction. For example, some robotic pets will show simulated love if their owner pats their head several times. While such robotic pets are enjoyed by their owners, there is a continuing desire for new and innovative types of toys and particularly toy characters that interact with their owner.

SUMMARY OF THE DISCLOSURE

In an aspect, a toy assembly is provided, and includes a housing, an inner object (which may, in some embodiments, be a toy character), at least one sensor and a controller. The inner object is positioned inside the housing and includes a breakout mechanism that is operable to break the housing to expose the inner object. The at least one sensor detects interaction with a user. The controller is configured to determine whether a selected condition has been met based on at least one interaction with the user, and to operate the breakout mechanism to break the housing to expose the inner object if the condition is met. Optionally, the condition is met based upon having a selected number of interactions with the user.

According to another aspect, a method is provided for managing an interaction between a user and a toy assembly, wherein the toy assembly includes a housing and a toy character inside the housing. The method includes:

- a) receiving from the user a registration of the toy assembly;
- b) receiving from the user after step a), a first progress scan of the toy assembly;
- c) displaying a first output image of the toy character in a first stage of virtual development;
- d) receiving from the user after step c), a second progress scan of the toy assembly; and
- e) displaying a second output image of the inner object in a second stage of virtual development that is different than the first output image.

In another aspect, a toy assembly is provided. The toy assembly includes a housing, an inner object (which may, in some embodiments, be a toy character) inside the housing, a breakout mechanism that is associated with the housing and that is operable to break the housing to expose the inner object. The breakout mechanism is powered by a breakout mechanism power source that is associated with the housing.

2

Optionally, the breakout mechanism is inside the housing. As a further option, the breakout mechanism may be operable from outside the housing. Optionally, the breakout mechanism includes a hammer, positioned in association with the inner object, wherein the breakout mechanism power source is operatively connected to the hammer to drive the hammer to break the housing. Optionally, the breakout mechanism power source is operatively connected to the hammer to reciprocate the hammer to break the housing.

In another aspect, a toy assembly is provided, and includes a housing and a inner object (which may, in some embodiments, be a toy character) inside the housing, wherein the housing has a plurality of irregular fracture paths formed therein, such that the housing is configured to fracture along at least one of the fracture paths when subjected to a sufficient force.

In another aspect, a toy assembly is provided, and includes a housing and a inner object (which may, in some embodiments, be a toy character) inside the housing in a pre-breakout position. The inner object includes a functional mechanism set. The inner object is removable from the housing and is positionable in a post-breakout position. When the inner object is in the pre-breakout position, the functional mechanism set is operable to perform a first set of movements. When the inner object is in the post-breakout position, the functional mechanism set is operable to perform a second set of movements that is different than the first set of movements. In an example, the inner object further includes, a breakout mechanism, a breakout mechanism power source, at least one limb and a limb power source that all together form part of the functional mechanism set. When the inner object is in the pre-breakout position, the limb power source is operatively disconnected from the at least one limb, and so movement of the limb power source does not drive movement of the at least one limb. However, in the pre-breakout position, the breakout mechanism power source drives movement of the breakout mechanism so as to break the housing and expose the inner object. When the inner object is in the post-breakout position the limb power source is operatively connected to the at least one limb and can drive movement of the limb, but the breakout mechanism is not driven by the breakout mechanism power source.

In another aspect, a polymer composition is provided, the polymer composition including about 15-25 weight-% base polymer; about 1-5 weight-% organic acid metal salt; and about 75-85 weight-% inorganic/particulate filler.

In another aspect, an article of manufacture is provided, the article of manufacture formed of the polymer composition including about 15-25 weight-% base polymer; about 1-5 weight-% organic acid metal salt; and about 75-85 weight-% inorganic/particulate filler.

In another aspect, a toy assembly is provided and includes a housing, and a inner object (which may, in some embodiments, be a toy character) inside the housing, wherein the inner object includes a breakout mechanism that is operable to break the housing to expose the inner object, and wherein the housing includes a plurality of fracture elements provided on an inside face thereof to facilitate fracture upon impact from the breakout mechanism.

In another aspect, a housing fracturing mechanism is provided, and includes a first frame member, a second frame member rotatably coupled to the first frame member, an aperture in which a housing to be broken is positioned, and at least one cutting element pivotally coupled to the first frame member and slidably coupled to the second member that is pivoted between a first position in which the at least

one cutting element is adjacent the housing when placed in the aperture and a second position in which the at least one cutting element intersects the housing when placed in the aperture.

In still yet another aspect, a toy assembly is provided, comprising a housing, an inner object inside the housing, and a breakout mechanism that is associated with the housing and that is operable to break the housing to expose the inner object, wherein the breakout mechanism exhibits an additional behavior when placed back into the housing.

BRIEF DESCRIPTIONS OF THE DRAWINGS

For a better understanding of the various embodiments described herein and to show more clearly how they may be carried into effect, reference will now be made, by way of example only, to the accompanying drawings in which:

FIGS. 1A and 1B are transparent side view of a toy assembly according to a non-limiting embodiment;

FIG. 2 is a transparent, perspective view of a housing that is part of the toy assembly shown in FIGS. 1A and 1B;

FIG. 3 is a perspective view of a toy character that is part of the toy assembly shown in FIGS. 1A and 1B;

FIG. 4 is a sectional side view of the toy character shown in FIG. 2, in a pre-breakout position, prior to engagement of a hammer that is part of a breakout mechanism;

FIG. 5 is a sectional side view of the toy character shown in FIG. 2, in a pre-breakout position, after engagement of a hammer that is part of a breakout mechanism;

FIG. 6 is a perspective view of a portion of the toy character that causes rotation of the toy character inside the housing;

FIG. 6A is a sectional side view of the portion of the toy character shown in FIG. 6;

FIG. 7 is a sectional side view of the toy character shown in FIG. 2, in a post-breakout position, showing the hammer extended;

FIG. 8 is a sectional side view of the toy character shown in FIG. 2, in a post-breakout position, showing the hammer retracted;

FIG. 9 is a perspective view of a portion of the toy assembly shown in FIGS. 1A and 1B, showing sensors that are part of the toy assembly;

FIG. 10A is a front elevation view of a portion of the toy assembly, illustrating a limb of the toy character in a non-functional, pre-breakout position as it is positioned when inside the housing;

FIG. 10B is a rear perspective view of the portion of the toy assembly, further illustrating the limb of the toy character in the non-functional, pre-breakout position as it is positioned when inside the housing;

FIG. 10C is a magnified front elevation view of a joint between a limb and a character frame of the toy character;

FIG. 10D is a perspective view of the portion of the toy assembly illustrating the limb of the toy character in the functional, post-breakout position as it is position when outside the housing;

FIG. 11 is a perspective view of the toy assembly and an electronic device used to scan the toy assembly;

FIG. 12 is a schematic view illustrating the uploading the scan of the toy assembly to a server;

FIG. 13A is a schematic view illustrating transmitting an output image from the server to be displayed electronically showing a first virtual stage of development for the toy character;

FIG. 13B is a schematic view illustrating transmitting an output image from the server to be displayed electronically showing a second virtual stage of development for the toy character;

FIG. 14 is a flow diagram of a method of receiving the scan from the electronic device and depicting the toy character based on steps illustrated in FIGS. 11 and 13;

FIG. 15 is a schematic side view of a housing presented in the form of an egg shell having a combination of continuous and discontinuous fracture paths formed therein;

FIG. 16 is a perspective view of a housing presented in the form of an egg shell having a plurality of continuous fracture paths arranged in a random pattern;

FIG. 17A is a schematic side view of a housing presented in the form of an egg shell having a plurality of continuous fracture paths arranged in a geometric pattern;

FIG. 17B is a perspective view of the housing of FIG. 17A, showing in greater detail the geometric pattern of the fracture paths;

FIG. 18 is perspective view of a housing presented in the form of an egg shell having a plurality of discontinuous fracture paths arranged in a random pattern;

FIG. 19A is a schematic side view of a housing presented in the form of an egg shell having a plurality of fracture units arranged in a random pattern;

FIG. 19B is a perspective view of a housing presented in the form of an egg shell having a plurality of fracture units arranged in a regular repeating pattern;

FIG. 20 is a sectional side view of a breakout mechanism forming part of a toy assembly according to another non-limiting embodiment prior to activation via release of a tab;

FIG. 21 is a side exploded view of the breakout mechanism of FIG. 20;

FIG. 22 is another sectional side view of the breakout mechanism of FIG. 20 after activation via release of the tab;

FIG. 23 is a side sectional view of a housing according to another non-limiting embodiment presented in the form of an egg shell having a plurality of continuous fracture paths formed therein;

FIG. 24 is an exploded view of a number of components of another breakout mechanism forming part of a toy assembly according to a further non-limiting embodiment;

FIG. 25 is a side sectional view of the breakout mechanism of FIG. 24 inside a housing prior to activation of the breakout mechanism;

FIG. 26 is a side sectional view of the breakout mechanism of FIG. 25 protruding through the housing after activation;

FIG. 27 is a side view of a breakout mechanism according to yet another non-limiting embodiment;

FIG. 28 is a top view of a housing fracturing mechanism according to a further non-limiting embodiment;

FIG. 29 is a top sectional view of the housing fracturing mechanism of FIG. 28 showing a housing being fractured;

FIG. 30 is a side sectional view of the housing fracturing mechanism of FIG. 28;

FIG. 31A is a top view of a housing fracturing mechanism according to yet another non-limiting embodiment having two pivotally-connected members;

FIG. 31B is a top view of the housing fracturing mechanism of FIG. 31A wherein the two members have been pivoted relative to one another to restrict an aperture defined by the two members;

FIG. 32A is a front view of a breakout mechanism in accordance with another embodiment in an expanded state;

5

FIG. 32B is a front view of a companion mechanism for placement in a housing with the breakout mechanism of FIG. 32A;

FIG. 33 shows the breakout mechanism of FIG. 32A and the companion mechanism of FIG. 32B in a stacked compacted state;

FIG. 34 is a sectional view of a housing in the form of an egg having two toy characters employing a breakout mechanism similar to that of FIG. 32A and a companion mechanism similar to that of FIG. 32B respectively;

FIG. 35 is a front cross section view of a smaller companion mechanism than that of FIG. 32B for placement in a housing with a breakout mechanism such as that of FIG. 32A;

FIG. 36 is a partial sectional front view of a breakout mechanism similar to that of FIG. 32A and two of the companion mechanisms of FIG. 35 in a stacked compacted state;

FIG. 37 is a sectional view of a housing in the form of an egg having three toy characters employing a breakout mechanism similar to that of FIG. 32A and two companion mechanisms as shown in FIG. 36 respectively;

FIG. 38 is a partial sectional view of a housing, an adapter disk, and a breakout mechanism in accordance with yet another embodiment;

FIG. 39 is a top perspective view of a bottom portion of the housing of FIG. 38;

FIG. 40A is a top perspective view of the adapter disk of FIG. 38; and

FIG. 40B is a bottom perspective view of the adapter disk of FIG. 38.

DETAILED DESCRIPTION

Reference is made to FIGS. 1A and 1B, which show a toy assembly 10 in accordance with an embodiment of the present disclosure. The toy assembly 10 includes a housing 12 and a toy character 14 that is positioned in the housing 12. For the purposes of showing the toy character 14 inside the housing 12, parts of the housing 12 are shown as transparent in FIGS. 1A and 1B, however the housing 12 may, in the physical assembly, be opaque in the sense that, under typical ambient lighting conditions, the toy character 14 would be not visible to a user through the housing 12. In the embodiment shown, the housing 12 is in the form of an egg shell and the toy character 14 inside the housing 12 is in the form of a bird. However, the housing 12 and toy character 14 may have any other suitable shapes. For manufacturing purposes, the housing 12 may be formed from a plurality of housing members, individual shown as a first housing member 12a, a second housing member 12b and a third housing member 12c, which are fixedly joined together so as to substantially enclose the toy character 14. In some embodiments the housing 12 could alternatively only partially enclose the toy character 14 so that the toy character could be visible from some angles even when it is inside the housing 12.

The toy character 14 is configured to break the housing 12 from within the housing 12, as to expose the toy character 14. In embodiments in which the housing 12 is in the form of an egg, the act of breaking the housing 12 will appear to the user as if the toy character 14 is hatching from the egg, particular in embodiments in which the toy character 14 is in the form of a bird, or some other animal that normally hatches from an egg, such as a turtle, a lizard, a dinosaur, or some other animal.

Referring to the transparent view in FIG. 2, the housing 12 may include a plurality of irregular fracture paths 16 formed

6

therein. As a result, when the toy character 14 breaks the housing 14 it appears to the user that the housing 12 has been broken randomly by the toy character 14, to impart realism to the process of breaking the housing. The irregular fracture paths 16 may have any suitable shape. For example, the fracture paths 16 may be generally arcuate, so as to inhibit the presence of sharp corners in the housing 12 during breakage of the housing 12 by the toy character 14. The irregular fracture paths 16 may be formed in any suitable way. For example, the fracture paths may be molded directly into one or more of the housing members 12a-12c. In the example shown, the fracture paths 16 are provided on the inside face (shown at 18) of the housing 12 so as to not be visible to the user prior to breakage of the housing 12. As a result of the fracture paths 16, the housing 12 is configured to fracture along at least one of the fracture paths 16 when subjected to a sufficient force.

The housing 12 may be formed of any suitable natural or synthetic polymer composition, depending on the desired performance (i.e., breakage) properties. When presented in the form of an egg shell, as shown for example in FIG. 1A, the polymer composition may be selected so as to exhibit a realistic breakage behavior upon impact from the breakout mechanism 22 of the toy character 14. In general, suitable materials for a simulated breakable egg shell may exhibit one or more of low elasticity, low plasticity, low ductility and low tensile strength. Upon action by the breakout mechanism 22, the material should fracture, without significant absorption of the impact force. In other words, upon impact by the breakout mechanism 22, the material should not significantly flex, but rather fracture along one or more of the defined fracture elements. In addition, the polymer composition may be selected to demonstrate breakage without the formation of sharp edges. During the breakage event, the selected polymer composition should enable broken and loosened pieces to separate and fall cleanly away from the housing 12, with minimal unrealistic hanging due to flex or bending at undetached points.

It has been determined that polymer compositions having high filler content relative to the base polymer exhibit performance properties desired for simulating a breaking egg shell. An exemplary composition having high filler content may comprise about 15-25 weight-% base polymer, about 1-5 weight-% organic acid metal salt and about 75-85 weight-% inorganic/particulate filler. It will be appreciated that a variety of base polymers, organic acid metal salts and fillers may be selected to achieve the desired performance properties. In one exemplary embodiment suitable for use in forming the housing 12, the composition is comprised of 15-25 weight-% ethylene-vinyl acetate, 1-5 weight-% zinc stearate and 75-85 weight-% calcium carbonate.

While exemplified using ethylene-vinyl acetate, it will be appreciated that a variety of base polymers may be used depending on the desired performance properties. Alternatives for the base polymer may include select thermoplastics, thermosets and elastomers. For example, in some embodiments, the base polymer may be a polyolefin (i.e., polypropylene, polyethylene). It will be further appreciated that the base polymer may be selected from a range of natural polymers used to produce bioplastics. Exemplary natural polymers include, but are not limited to, starch, cellulose and aliphatic polyesters.

While exemplified using calcium carbonate, it will be appreciated that an alternative particulate filler may be suitably used. Exemplary alternatives may include, but are not limited to, talc, mica, kaolin, wollastonite, feldspar, and aluminum hydroxide.

With reference to FIG. 2, where the housing 12 is provided in the form of an egg shell, the wall thickness in structural regions 17, that is on portions of the housing 12 surrounding the fracture elements (shown in FIG. 2 as fracture paths 16) may be in the range of 0.5 to 1.0 mm. The selected wall thickness may take into account a number of factors, including ease of molding (i.e., injection molding), in particular with respect to melt flow performance through the mold tool for a selected polymer composition. For the exemplary polymer composition noted above, that is the composition comprised of 15-25 weight-% ethylene-vinyl acetate, 1-5 weight-% zinc stearate and 75-85 weight-% calcium carbonate, a wall thickness of 0.7 to 0.8 mm for the structural regions 17 may be selected to achieve good molding performance. With this composition, a thickness of 0.7 to 0.8 mm for the structural region 17 has also been found to provide sufficient strength to maintain the integrity of the housing 12 during transport and handling, particularly when being handled by children.

The arrangement of the plurality of fracture paths 16 formed on the inside face 18 of the housing 12 serves to facilitate the process of breaking the housing 12 by the breakout mechanism 22. In a housing 12 provided in the form of a breakable egg shell, the fracture paths 16 are generally provided in a breakage zone 19 of the first housing member 12a. It will be appreciated, however, that the breakage zone 19 may be provided in one or more of the various housing members 12a, 12b, 12c. The fracture paths 16 may be formed in either a random or regular (i.e., geometric) pattern, depending on the desired breakage behavior. Turning to FIGS. 15 to 19B, shown are a number of exemplary fracture elements that may be formed into the housing 12.

FIG. 15 shows an embodiment where the fracture elements are presented as fracture paths 16 in the breakage zone 19, the fracture paths 16 including a combination of continuous (i.e., interconnected) and discontinuous (i.e., dead-end) channels 21 formed on the inside face 18 of the housing 12. To facilitate breakage, the channels 21 are positioned so as to provide a generally continuous centrally-located fracture path (shown as dotted line C) through the breakage zone 19. The fracture paths 16 define a region of reduced wall thickness, generally 40 to 60% thinner in comparison to the wall thickness of the structural regions 17. In some embodiments, the fracture paths 16 are dimensioned to present a wall thickness that is 50% thinner than the wall thickness of the surrounding structural region 17. Accordingly, where a housing 12 is provided having a wall thickness of 0.8 mm in the structural region 17, the fracture paths 16 will generally exhibit a wall thickness of 0.4 mm. As shown, the width of the channels 21 vary between 0.5 to 1.5 mm along the length thereof, with some channels exhibiting a generally decreasing width towards the terminal (i.e., dead-end) regions thereof.

FIG. 16 shows an embodiment where the fracture elements are presented as fracture paths 16 in the breakage zone 19, the fracture paths 16 being randomly positioned, and where the channels 21 forming the fracture paths 16 are continuous (i.e., interconnected) therethrough. Similar to the embodiment of FIG. 15, the fracture paths 16 in FIG. 15 define a region of reduced wall thickness, generally 40 to 60% thinner in comparison to the wall thickness of the structural regions 17. In some embodiments, the fracture paths 16 are dimensioned to present a wall thickness that is 50% thinner than the wall thickness of the surrounding structural region 17. Accordingly, where a housing 12 is provided having a wall thickness of 0.8 mm in the structural

region 17, the fracture paths 16 will generally exhibit a wall thickness of 0.4 mm. Although the width of the channels 21 may vary, in particular at regions where two or more channels intersect, the channels are formed having a width generally in the range of 0.8 to 1.2 mm.

FIG. 17A shows an embodiment where the fracture elements are presented as fracture paths 16 in the breakage zone 19, the fracture paths 16 being arranged in a geometric pattern, and where the channels 21 forming the fracture path 16 are continuous (i.e., interconnected) therethrough. As shown, the geometric pattern includes a plurality of hexagons arranged in a grid, where the perimeter (i.e., sides) of the hexagons define the fracture path 16. Each hexagon is further provided with a central fracture path 16a bisecting the hexagon, either through opposing vertices, or opposing sides. Similar to the embodiment of FIG. 15, the fracture paths 16/16a in FIG. 17A define a region of reduced wall thickness, generally 40 to 60% thinner in comparison to the wall thickness of the structural regions 17. In some embodiments, the fracture paths 16/16a are dimensioned to present a wall thickness that is 50% thinner than the wall thickness of the surrounding structural region 17. Accordingly, where a housing 12 is provided having a wall thickness of 0.8 mm in the structural region 17, the fracture paths 16/16a will generally exhibit a wall thickness of 0.4 mm. Within each geometric shape, the area delimited by the surrounding fracture paths 16 may be formed with uniform wall thickness. In an alternative arrangement, the region 25 delimited by the surrounding fracture paths 16 may be tapered as shown in FIG. 17b. As shown, each region 25 includes a central ridge 27 having a first thickness (i.e., similar to or greater than the thickness of the structural region 17) and a plurality of tapered walls 29 extending from the central ridge 27 in the direction towards an adjacent fracture paths 16. In comparison to the embodiments of FIGS. 15 and 16, the width of the channels 21 is more uniform where the fracture paths 16 are arranged in a geometric pattern. Although the width of the channels may vary, the channels in some embodiments may be formed having a width of approximately 0.8 mm.

FIG. 18 illustrates an embodiment where the breakage zone 19 includes a series closely associated but discontinuous and randomly positioned fracture elements (shown as fracture units 23). Each fracture unit 23 generally presents in the form of a T- or Y-shaped channel, having a width of 0.5 to 1.5 mm. The fracture unit 23 defines a region of reduced wall thickness, generally in the region of 40 to 60% compared to the wall thickness of the structural regions 17. In some embodiments, the fracture units 23 are dimensioned to present a wall thickness that is 50% thinner than the wall thickness of the surrounding structural region 17. Accordingly, where a housing 12 is provided having a wall thickness of 0.8 mm in the structural region 17, the fracture units 23 will generally exhibit a wall thickness of 0.4 mm.

With reference to FIGS. 19A and 19B, shown are additional alternative embodiments where a discontinuous array of fracture elements is provided to establish the breakage zone 19. FIGS. 19A and 19B present a plurality of fracture elements (shown as fracture units 23) in the form of a circular and/or oval depressions formed in the housing 12. The circular and/or oval fracture units 23 may be provided in various sizes and orientations, to achieve a generally random breakage behavior. In addition, the fracture units 23 may be arranged in a generally random pattern, as shown in FIG. 19A, or in a regular repeating pattern as shown in FIG. 19B. The fracture units 23 in FIGS. 19A and 19B define a region of reduced wall thickness, generally 40 to 60%

thinner in comparison to the wall thickness of the structural regions 17. In some embodiments, the fracture units 23 are dimensioned to present a wall thickness that is 50% thinner than the wall thickness of the surrounding structural region 17. Accordingly, where a housing 12 is provided having a wall thickness of 0.8 mm in the structural region 17, the fracture units 23 will generally exhibit a wall thickness of 0.4 mm.

The fracture elements (fracture paths 16/fracture units 23) may account for 20 to 80% of the area within the breakage zone 19. In some embodiments where the housing is required to fracture at a higher impact force, the fracture paths/units may account for 20 to 30% of the area within the breakage zone 19. Conversely, where the housing 12 is required to fracture at a lower impact force, the fracture elements may account for 70% to 80% of the area within the breakage zone 19. In the embodiments shown in FIGS. 15 through 19B, the fracture elements account for approximately 40 to 60% of the area within the breakage zone. Selection the proportion of fracture elements relative to the structural region of the housing 12 will consider a number of factors, including, but not limited to, the materials used, the forces required to fracture the housing, as well as the shape of the housing. For example, in an embodiment where the polymer composition incorporates a base polymer having higher strength characteristics compared to ethylene-vinyl acetate, the housing may require a higher proportion of fracture elements (i.e., 70% to 80%) to achieve housing fracture under the same impact conditions. It will be appreciated that other embodiments may incorporate a proportion of fracture elements that may be less than 20%, or greater than 80%, depending on the intended application and the impact forces used to achieve housing fracture.

Although the housing 12 has been exemplified in the form of an egg shell, it will be appreciated that the materials and molding features discussed above may be applied to other articles of manufacture, including but not limited to other housing configurations as well as consumer packaging. For example, where the toy character is provided in the form of an action figure, the housing may be provided in the form of a building, with the action figure being configured to impact the housing from the inside upon being activated. It will be appreciated that a multitude of toy/housing combinations may be possible.

The toy character 14 is shown mounted only on the housing member 12c in FIG. 3. Referring to FIGS. 4 and 5, the toy character 14 includes a toy character frame 20, a breakout mechanism 22, a breakout mechanism power source 24 and a controller 28.

The breakout mechanism 22 is operable to break the housing 12 (e.g., to fracture the housing 12 along at least one of the fracture paths 16) to expose the toy character 14. The breakout mechanism 22 includes a hammer 30, an actuation lever 32 and a breakout mechanism cam 34. The hammer 30 is movable between a retracted position (FIG. 4) in which the hammer 30 is spaced from the housing 12 and an advanced position (FIG. 5) in which the hammer 30 is positioned to break the housing 12.

The actuation lever 32 is pivotably mounted via a pin joint 40 to the toy character frame 20 and is movable between a hammer retraction position (FIG. 4) in which the actuation lever 32 is positioned to permit the hammer 30 to move to the retracted position, and a hammer driving position (FIG. 5) in which the actuation lever 32 drives the hammer 30. The actuation lever 32 is biased towards the hammer driving position by an actuation lever biasing member 38. In other words, the actuation lever 32 is biased by the biasing

member 38 towards driving the hammer 30 to the extended position. The actuation lever 32 has a first end 42 with a cam engagement surface 44 thereon, and a second end 46 with a hammer engagement surface 48 thereon, which will be described further below.

The breakout mechanism cam 34 may sit directly on an output shaft (shown at 49) of a motor 36 and is thus rotatable by the motor 36. The breakout mechanism cam 34 has a cam surface 50 that is engaged with the cam engagement surface 44 on the first end 42 of the actuation lever 32. When the breakout mechanism cam 34 is rotated by the motor 36 (in the clockwise direction in the views shown in FIGS. 4 and 5), from the position shown in FIG. 4 to the position shown in FIG. 5) a stepped region shown at 51 on the cam surface 50 causes the cam surface 50 to drop away from the actuation lever 32 abruptly, permitting the biasing member 38 to accelerate the actuation lever 32 to impact at relatively high speed with the hammer 30, thereby driving the hammer 30 forward (outward) from the frame 20 at relatively high speed, which provides a high impact energy when the hammer 30 hits the housing 12, so as to facilitate breaking of the housing 12. In some embodiments, this will present the appearance of a bird pecking its way out of an egg.

As the breakout mechanism cam 34 continues to rotate, the cam surface 50 draws the actuation lever 32 back to the retracted position that is shown in FIG. 4. The hammer engagement surface 48 of the actuation lever 32 may have a first magnet 52a there in that is attracted to a second magnet 52b in the hammer 30. As a result, during the drawing back of the actuation lever 32, the actuation lever 32 pulls the hammer 30 back to a retracted position shown in FIG. 4.

The breakout mechanism cam 34 is rotatable by the motor 36 to cyclically cause retraction of the actuation lever 32 from the hammer 30 and then release of the actuation lever 32 to be driven into the hammer 30 by the actuation lever biasing member 38. Thus, the motor 36 and the actuation lever biasing member 38 may together make up the breakout mechanism power source 24.

The breakout mechanism biasing member 38 may be a helical coil tension spring as shown in the figures, or alternatively it may be any other suitable type of biasing member.

Additionally, the toy character 14 includes a rotation mechanism shown at 53 in FIG. 6. The rotation mechanism 53 is configured to rotate the toy character 14 in the housing 12. The controller 28 is configured to operate the rotation mechanism 53 when operating the breakout mechanism in order to break the housing 12 in a plurality of places.

The rotation mechanism 53 may be any suitable rotation mechanism. In the embodiment shown in FIG. 6, the rotation mechanism 53 includes a gear 54 that is fixedly mounted to the bottom housing member 12c. The output shaft 49 of the motor 36 is a dual output shaft that extends from both sides of the motor 36 and drives first and second wheels 56a and 56b. On one of the wheels, (in the example shown, on the first wheel 56a) is a drive tooth 58. When the motor 36 turns the output shaft 49, the drive tooth 58 on the first wheel 56a engages the gear 54 once per revolution of the output shaft 49 and drives the toy character 14 to rotate relative to the housing 12. A bushing 60 supports the toy character 14 for rotation about the axis (shown at Ag) of the gear 54. In the example shown, the bushing 60 is slidably, rotatably engaged with a shaft 62 of the gear 54, and is axially supported on support surface 64 of the bottom housing member 12c, as shown in FIG. 6A. The toy character 14 may be releasably held to the bushing 60 via projections 66 on the

11

bushing 60 that engage apertures 68 on the toy character frame 20. When the toy character 14 is desired to be removed from the bushing 60, a user may pull the toy character 14 off of the projections 66. The bushing 60 also supports the wheels 56a and 56b off of the housing 12. As a result, while the toy character 14 is in the housing 12, rotational indexing of the toy character 14 takes place by sliding of the bushing 60 on the bottom housing member 12c and without engagement of the wheels 56a and 56b on the housing member 12c.

As can be seen from the description above, once per revolution of the output shaft 49, the rotation mechanism 53 rotates the toy character 14 by a selected angular amount (i.e., the rotation mechanism 53 rotationally indexes the toy character 14), and the actuation lever 32 is drawn back to a retracted position and then released to drive the hammer 30 forward to engage and break the housing 12. Thus, continued rotation of the motor 36 causes the toy character 14 to eventually break through the entire perimeter of the housing 12.

Once the toy character 14 has broken through the housing 12, a user can help to free the toy character 14 from the housing 12. It will be noted that the housing member 12c may be left to serve as a base for the toy character 14 if desired in some embodiments. Once the toy character 14 is freed from the housing 12 and the hammer 30 is no longer needed to break through the housing 12, the user may move at least one release member from a pre-breakout position to a post-breakout position. In the example shown in FIG. 5, there are two release members, namely a first release member 70a, and a second release member 70b. Prior to breaking of the housing 12 to expose the toy character 14, the release members 70a and 70b are in the pre-breakout position. When in the pre-breakout position, the first release member 70a connects the first end (shown at 72) of the actuation lever biasing member 38 to the toy character frame 20. The second end (shown at 74) of the biasing member 38 is connected to the actuation lever 32, and therefore, the biasing member 38 is connected to drive the hammer 30 forward (via actuation of the actuation lever 32) to break the housing 12. Movement of the release member 70a to the post-breakout position in the example shown, entails removal of the release member 70a such that the biasing member 38 is disabled from driving the actuation lever 32 and therefore the hammer 30, as shown in FIG. 7. As a result, when the motor 36 rotates, which causes rotation of the breakout mechanism cam 34, the passing of the stepped region 51 of the cam surface 50 does not cause the actuation lever 32 to be driven into the hammer 30.

With reference to FIG. 4, the second release member 70b, when in the pre-breakout position, holds a locking lever 78 in a locking position so as to hold a hammer biasing structure 80 in a non-use position. In the non-use position the hammer biasing structure 80 is fixedly held to the actuation lever 32 and acts as one with the actuation lever 32. With reference to FIGS. 7 and 8, when the second release member 70b is moved from the pre-breakout position to the post-breakout position, the locking lever 78 releases the hammer biasing structure 80. The hammer biasing structure 80 includes a pivot arm 82 that is pivotally connected to the actuation lever 32 (e.g., via a pin joint 84), and a pivot arm biasing member 86 that may be a compression spring or any other suitable type of spring that acts between the actuation lever 32 and the pivot arm 82 so as to urge the pivot arm 82 into the hammer 30 to urge the hammer 30 towards the extended position shown in FIG. 7. As a result, the hammer 30 can integrate into the toy character's appearance. In the

12

embodiment shown, wherein the toy character 14 is in the form of a bird, the hammer 30 is the beak of the bird. Because the hammer 30 is urged outwards by the biasing member 86 and is not locked in the extended position, it may be pushed in against the biasing force of the biasing member 86 by an external force (e.g., by the user), as shown in FIG. 8, which can reduce the risk of a poking injury to a child playing with the toy character 14.

Any suitable scheme may be used to initiate breaking out of the housing 12 by the toy character 14. For example, as shown in FIG. 9, at least one sensor may be provided in the toy assembly 10 which detects interaction with a user while the toy character 14 is in the housing 12. For example, a capacitive sensor 90 may be provided on the bottom of the housing member 12c so as to detect holding by a user. A microphone 92 may be provided on the toy character frame 20 to detect audio input by a user. A pushbutton 94 may be provided on the front of the toy character 14. A tilt sensor 96 may be provided on the toy character 14 to detect tilting of the toy character 14 by the user. The controller 28 may count the number of interactions that a user has had with the toy assembly 10 and operate the breakout mechanism 22 so as to break the housing 12 and expose the toy character 14 if a selected condition is met. For example, the condition may be a selected number of interactions with a user, such as 120 interactions. Interaction with the toy character 14 using the microphone 92 could entail the user saying a command that is recognized by the controller 28, or alternatively it could entail the user making any kind of noise such as a clap or a tap, which would be received by the microphone 92. An interaction could entail the user holding or touching the housing 12 in places where the capacitive sensor will receive it. In another example, an interaction could entail the user pushing the pushbutton 94 of the toy character 14 by pressing on the correct spot on the housing 12, which may be sufficiently flexible and resilient to transmit the force of the press through to the pushbutton 94. The pushbutton 94 may control operation of an LED 95 that is inside the toy character 14 and is sufficiently bright to view through the housing 12. The LED 95 may illuminate in different colours (controlled by the controller 28) to indicate to the user the 'mood' of the toy character 14, which may depend on factors including the interactions that have occurred between the toy character 14 and the user.

When the toy character 14 is outside of the housing 12, the toy character 14 may carry out movements that are different than those carried out inside the housing 12. For example, the toy character 14 may have at least one limb 96. In the example shown, there are provided two limbs 96 which are shown as wings but which may be any suitable type of limb. When inside the housing, the wings 96 are positioned in a pre-breakout position in which they are non-functional, as shown in FIGS. 10A, 10B and 10C, and, when outside the housing, are positioned in a post-breakout position in which they are functional, as shown in FIG. 10D. As shown in FIG. 10D, the wings 96 are connected to the character frame 20 via a wing connector link 100 that is pivotally mounted at one end to the associated wing 96 and at another end to the character frame 20. For each wing 96, a wing driver arm 104 is pivotally connected at one end to the associated wing 96 and has a wing driver arm wheel 106 at the other end. The wing driver arm wheels 106 rest on the toy character's main wheels 56a and 56b when the toy character 14 is in the post-breakout position. The toy character's main wheels 56a and 56b have a cam profile on them with at least one lobe 108 on each wheel (shown in FIG. 6, in which two lobes 108 are provided on each wheel). The lobes 108 serve two

13

purposes. Firstly, as the motor 36 turns, the wheels 56a and 56b drive the toy character 14 along the ground, and the lobes 108 lend a wobble to the toy character 14 to give it a more lifelike appearance when it rolls along the ground. Secondly, as the wheels 56a and 56b turn, the presence of the lobes 108 cause the wheels 56a and 56b to act as wing driver cams, which drive the wing driver arms 104 up and down as the wing driver arm wheels 106 follow the cam profiles of the main wheels 56a and 56b. The up and down movement of the wing driver arms 104 in turn, drives the wings 96 to pivot up and down, giving the toy character 14 the appearance of flapping its wings as it travels along the ground. Preferably, the lobes 108 on the first wheel 56a are offset rotationally relative to the lobes 108 on the second wheel 56b so that the toy character 14 has a side-to-side wobble as the toy character rolls to enhance the lifelike appearance of its motion.

For each wing connector link 100, a wing connector link biasing member 102 (FIG. 10C) biases the associated wing connector link 100 to urge the associated wing 96 downward to maintain contact between the driver arm wheels 106 and the main wheels 56a and 56b when the character is in the post-breakout position shown in FIG. 10D.

In the example shown, where the limbs 96 are wings, the driver arms 104 are referred to as wing driver arms, the driver arm wheels 106 are referred to as wing driver arm wheels 106 and the wheels 56a and 56b are referred to as wing driver cams. However, it will be understood that if the wings 96 were any other suitable type of limbs, the driver arms 104 and the driver arm wheels 106 may more broadly be referred to as limb driver arms 104 and limb driver arm wheels 106 respectively, and the wheels 56a and 56b may be referred to as limb driver cams.

The motor 36 drives the limbs 96 in the example shown, by driving the wheels 56a and 56b. Thus, when the limbs 96 are in the post-breakout position, the motor 36 is operatively connected to the limbs 96.

The motor 36 is thus the limb power source. However, the motor 36 is just an example of a suitable limb power source, and alternatively any other suitable type of limb power source could be used to drive the limbs 96.

When the wings 96 are in the pre-breakout position (FIGS. 10A-10C), the links 100 may hinge relative to the character frame 20 as needed so that the wings fit within the confines of the housing 12. In the example shown the wing connector links 100 hinge upwardly against the biasing force of the biasing members 102. While in the housing 12, the wings 96 thus remain in their non-functional position wherein the wing driver arms 104 are held such that the wing driver arm wheels 106 are disengaged from the toy character's main wheels 56a and 56b. Thus, the motor 36 (i.e., the limb power source) is operatively disconnected from the limbs 96 when the limbs 96 are in the pre-breakout position. As a result, when the toy character 14 is in the housing 12 and the motor 36 rotates (e.g., to cause movement of the breakout mechanism 22), the rotation of the main wheels 56a and 56b does not cause movement of the wings 96. As a result, the wings 96 do not cause damage to the housing 12 during operation of the motor 36 while the character 14 is in the housing 12.

The motor 36 depicted in the figures includes an energy source, which may be one or more batteries.

Reference is made to FIG. 11, which illustrates a way that a user can play with the toy assembly 10 prior to breakout of the toy character 14 from the housing 12. The lower housing member 12b is shown as transparent in FIG. 11 to show the toy character 14 inside. At a first point in time, the

14

user may scan the toy assembly 10 by any suitable means, such as by a camera 150 on a smartphone 152 to produce a first progress scan 153 of the toy assembly 10 (i.e., which may be an image of the toy assembly 10 taken from the smartphone camera 150). The user may then upload the scan 153 to a server 154 as part of, or after, registering the toy assembly 10 via a network such as the internet, shown at 156. The server 156 may, in response to the uploaded scan, generate an output image 158a representing a first virtual stage of development of the toy character 14 in the housing 12, so as to convey the impression to the user that the toy character 14 is a living entity growing inside the housing 12. The output image 158a may be displayed electronically (e.g., on the smartphone 152). The user may at a second, later point in time take a second progress scan 153 of the toy assembly 10 and may upload it to the server 154, whereupon the server 154 will generate a second output image 158b (shown in FIG. 13B) that represents a second virtual stage of development of the toy character 14 inside the housing 12. In the second virtual stage of development the toy character 14 may appear to be further developed than in the first virtual stage of development.

FIG. 14 is a flow diagram of a method 200 of managing an interaction between a user and the toy assembly 10 in accordance with the actions depicted in FIGS. 11-13. The method 200 begins at 201, and includes a step 202 which is receiving from the user a registration of the toy assembly 14. This may take place by receiving from a user, information regarding the model number or serial number of the toy assembly 14. Step 204 includes receiving from the user after step 202, a first progress scan of the toy assembly, as depicted in FIG. 12. Step 206 includes displaying an image of the toy character 14 in a first stage of virtual development, as depicted in FIG. 13A. Step 208 includes receiving from the user after step 206, a second progress scan of the toy assembly 10, as depicted in FIG. 12 again. Step 210 includes displaying a second output image 158b of the toy character 14 in a second stage of virtual development that is different than the first output image 158a depicting the first stage of development, as shown in FIG. 13B.

While it has been described for the toy assembly 10 to include a controller and sensors, and to include the breakout mechanism inside the toy character 14, many other configurations are possible. For example, the toy assembly 10 could be provided without a controller or any sensors. Instead the toy character 14 could be powered by an electric motor that is controlled via a power switch that is actuatable from outside the housing 12 (e.g., the switch may be operated by a lever that extends through the housing 12 to the exterior of the housing 12).

The breakout mechanism 22 has been shown to be provided inside the toy character 14. It will be understood that this location is just an example of a location in association with the housing 12 in which the breakout mechanism 22 can be positioned. In other embodiments, the breakout mechanism can be positioned outside the housing 12, while remaining in association with the housing 12. For example, in embodiments in which the housing 12 is shaped like an egg (as is the case in the example shown in the figures), a 'nest' can be provided, which can hold the egg. The nest may have a breakout mechanism built into it that is actuatable to break the egg to reveal the toy character 14 within. Thus, in an aspect, a toy assembly may be provided, that includes a housing, such as the housing 12, a toy character inside the housing, that is similar to the toy character 14 but wherein a breakout mechanism is provided that is associated with the housing, whether the breakout mechanism is within the

15

housing or outside of the housing, or partially within and partially outside of the housing, and that is operable to break the housing 12 to expose the toy character 14. The breakout mechanism is powered by a breakout mechanism power source (e.g., a spring, or a motor) that is associated with the housing 12. In some embodiments (e.g., as shown in FIG. 3), the breakout mechanism includes a hammer (such as the hammer 30), which the breakout mechanism power source is operatively connected to, so as to drive the hammer to break the housing 12. In some embodiments (e.g., as shown in FIG. 4), the breakout mechanism power source is operatively connected to the hammer to reciprocate the hammer to break the housing 12.

Another aspect of the invention relates to the movement of the toy character 14 when in the pre-breakout position and when in the post-breakout position. More specifically, the toy character 14 may be said to include a functional mechanism set that includes all of the movement elements of the toy character 14, including, for example, the limbs 96, the main wheels 56, the limb connector links 100 and associated biasing members 102, the limb driver arms 104, the driver arm wheels 106, the hammer 30, the actuation lever 32, the breakout mechanism cam 34, the motor 36 and the actuation lever biasing member 38. The toy character 14 is removable from the housing 12 and is positionable in a post-breakout position. When the toy character 14 is in the pre-breakout position, the functional mechanism set is operable to perform a first set of movements. In the example shown, the limb power source (i.e., the motor 36) is operatively disconnected from the limbs 96, and so movement of the limb power source 36 does not drive movement of the limbs 96. However, in the pre-breakout position, the breakout mechanism power source drives movement of the breakout mechanism 22 (by reciprocating the hammer 30 and indexing the toy character 14 around in the housing 12) so as to break the housing 12 and expose the toy character 14. When the toy character 14 is in the post-breakout position, the functional mechanism set that is operable to perform a second set of movements that is different than the first set of movements. For example, when the toy character 14 is in the post-breakout position the limb power source 36 is operatively connected to the limbs 96 and can drive movement of the limbs 96, but the breakout mechanism 22 is not driven by the breakout mechanism power source.

Some optional aspects of the play pattern for the toy assembly are described below. While the toy character 14 is in the housing 12 (when the toy character 14 is still in the pre-break out stage of development), the user can interact with the toy character in several ways. For example, the user can tap on the housing 12. The tapping can be picked up by the microphone on the toy character 14. The controller 28 can interpret the input to the microphone, and, upon determining that the input was from a tap, the controller 28 can output a sound from the speaker that is a tap sound, so as to appear as if the toy character 14 is tapping back to the user. Alternatively, or additionally, the controller 28 may initiate movement of the hammer 30 as described above, depending on whether the controller 28 can control the speed of the hammer 30, so as to knock the hammer 30 against the interior wall of the housing 12, lightly enough that it can be sensed by the user, but not so hard that it risks breaking the housing 12. The controller 28 may be programmed (or otherwise configured) to emit sounds indicating annoyance in the event that the user taps too many times within a certain amount of time or according to some other criteria. Optionally, if the user turns the toy assembly 10 upside down a first time, the controller 28 may be programmed to

16

emit a 'Mee!' sound from the speaker of the toy character 14. If the user turns the toy assembly 10 upside down more than a selected number of times within a certain period of time, then the controller 28 may be programmed to emit a sound (or some other output) that indicates that the toy character 14 is queasy. Optionally, when the controller 28 detects, via the capacitive sensors, that the user is holding the housing 12, the controller 28 may be programmed to emit a heartbeat sound from the toy character 14. Optionally, the controller 28 may be configured to indicate that it is cold using any suitable criteria and may be programmed to stop indicating that it is cold when the controller 28 detects that the user is holding or rubbing the housing 12. Optionally, the controller 28 is programmed to emit sounds indicating that the toy character 14 has the hiccups and to stop indicating this upon receiving a sufficient number of taps from the user. The controller 28 may be programmed to indicate to the user that the toy character 14 is bored and would like to play and may be programmed to stop such indication when the user interacts with the toy assembly 10.

Optionally, when the controller 28 has determined that the criteria have been met for it to leave the pre-break out stage of development and break out of the housing 12, the controller 28 may cause the LED to flash a selected sequence. For example, the LED may be caused to flash a rainbow sequence (red, then orange, then yellow, then green, then blue, then violet). After this, the toy character 14 may begin hitting the housing 12 a selected number of times, after which it may stop and wait for the user to interact further with it before beginning to hit the housing 12 again by a selected number of times.

Optionally, after the toy character 14 has initially broken out of the housing 12, the controller 28 may be programmed to act in a first stage of development after 'hatching' (i.e., after the toy character 14 is released from the housing 12) to emit sounds that are baby-like and to move in a baby-like manner, such as for example only being able to spin in a circle. During this first stage, the controller 28 may be programmed to require the user to interact with the toy character 14 in selected ways that symbolize petting of the toy character 14, feeding the toy character 14, burping the toy character 14, comforting the toy character 14, caring for the toy character 14 when the toy character 14 emits output that is indicative of being sick, putting the toy character 14 down for a nap, and playing with the toy character 14 when the toy character 14 emits output that is indicative of being bored. In this first stage, the toy character 14 may emit output that indicates fear from sounds beyond a selected loudness. In this stage, the toy character may generally emit baby-like sounds, such as gurgling sounds when the user attempts to communicate with it verbally.

Optionally, after some criteria are met during the first stage (e.g., a sufficient amount of time has passed, or a sufficient number of interactions (e.g., 120 interactions) have passed between the user and the toy character 14) the controller 28 may be programmed to change its mode of operation to a second stage after 'hatching' (i.e., after the toy character 14 is released from the housing 12). Optionally, the LED will emit the rainbow sequence again to indicate that the criteria have been met and that the toy character is changing its stage of development.

In the second stage of development, the toy character 14 can move linearly as well as moving in a circle. Additionally, the sounds emitted from the toy character 14 may sound more mature. Initially in the second stage of development after hatching, the controller 28 may be programmed to drive the toy character 14 to move linearly, but not

smoothly—the motor **38** may be driven and stopped in a random manner to give the appearance of a toddler learning to walk. Over time the motor **38** is driven with less stopping giving the toy character **14** the appearance of a more mature capability to ‘walk’. In this second stage of development, the toy character **14** may be capable of emitting sounds at the cadence that the user used when speaking to the toy character **14**. Also in this second stage of development, games involving interaction with the toy character **14** may be unlocked and played by the user.

FIG. **20** illustrates a breakout mechanism **300** in accordance with another embodiment of the present disclosure. The breakout mechanism **300** includes a base member **304** that is generally cup-shaped, having a feature, a plunger locking recess **308**, in its side wall and a slot **312** in its base wall. A plunger member **316** has a tubular body **320** and a rounded cap **324**. The outer circumference of the tubular body **320** of the plunger member **316** is dimensioned to be smaller than the internal circumference of the side wall of the base member **304**, enabling the tubular body **320** to shift laterally as needed within the base member **316**. A feature along the outer surface of the tubular body **320**, a protrusion **328**, at a proximal end of the body **320** (i.e. the opposite end from the rounded cap **324**) is sized to fit within the plunger locking recess **308** of the base member **304**.

A biasing element, in particular a spring **332**, is fitted inside of the tubular body **320** of the plunger member **316** and exerts a biasing force between the plunger member **316** and the base member **304**. A collar **336** is mounted (e.g. via a thermal bond, adhesive, or any other suitable means) around the tubular body **320** of the plunger member **316** and prevents the full exit of the plunger member **316** from the base member **304** via abutment of the protrusion **328** against the collar **336**. The spring **332** is in a compressed state between the rounded cap **324** of the plunger member **316** and the base wall of the base member **304** when the plunger member **316** is in a retracted position, in which the plunger member **316** within the base member **304**, as shown in FIG. **25**.

A release element, namely a wedge **340**, is inserted into the slot **312** when the plunger member **316** is fully inserted into the base member **304**, so as to hold the tubular body **320** of the plunger member **316** to one side of the interior of the base member **304** and positioning the protrusion **328** in the plunger locking recess **308**. A ridge **344** along the wedge **340** limits insertion of the wedge **340** into the slot **312**.

FIG. **21** shows the breakout mechanism **300** in a compacted state, wherein the plunger member **316** is in a retracted position within the base member **304** with the spring **332** in compression. The wedge **340** has been inserted into the slot **312**, and is biased against the tubular body **320** by an internal protuberance **346** within the slot, urging the tubular body **320** of the plunger member **316** to one side of the interior of the base member **304** and the protrusion **328** into the recess **308** to inhibit biasing of the plunger member **316** by the spring **332**.

The release element can, in some alternative embodiments, restrict expansion of the spring or other biasing element.

FIG. **22** shows the breakout mechanism in an expanded state. Removal of the wedge **340** enables the tubular body **320** of the plunger member **316** to shift within the base member **304**, permitting the protrusion **328** to exit the plunger locking recess **308** and releasing the plunger member **316** to be moved outwardly from the base member **304** by the separating force of the spring **332**.

The breakout mechanism **300** can form part of a toy character similar to the toy character **14**. For example, the plunger member **316** and the base member **304** may together be included in the housing of the toy character. Thus, the plunger member **316** and the base member **304** may be configured as needed so that they contribute to the appearance of a young bird, reptile, or the like. Further, the breakout mechanism **300** can be placed within a housing, such as an egg, that may be fractured via the biasing force of the spring **332** urging the plunger member **316** outwardly toward an extended position (FIG. **22**) relative to the base member **304**. The housing has an aperture permitting the wedge **340** to be removed from the breakout mechanism **300**. The spring **332** can exert a sufficiently strong biasing force to separate the plunger member **316** and the base member **304** and fracture a housing in which the breakout mechanism **300** is placed.

FIG. **23** is a sectional view of a housing in which the breakout mechanism **300** of FIGS. **21** to **23** may be deployed. The housing in this example is in the form of an simulated egg shell **360** that has a series of fracture paths **364** formed along its interior, the fracture paths **364** having a decreased shell thickness relative to the surrounding portions of the egg shell **360**. A wedge access aperture **368** in the egg shell **360** permits the pass-through of an end of the wedge **340** so as to permit a user to grasp the wedge **340** and remove it to activate the breakout mechanism **300**.

FIG. **24** illustrates a breakout mechanism **400** in accordance with another embodiment. The breakout mechanism **400** includes a base member **404** being formed of two base member portions **404a**, **404b**, and a plunger member **408** formed of two plunger member portions **408a**, **408b**. The base member **404** has a tubular side wall **412** with a generally hollow interior in which the plunger member **408** is received, and an interior lip **416** along the top of the side wall **412**. The plunger member **408** has a tubular side wall **420**, and an exterior ridge **424** along the bottom of the side wall **420** that cooperates with the interior lip **416** of the base member **404** to inhibit full exit of the plunger member **408** from the base member **404**. The plunger member **408** also has a set of internal walls **428** that define a channel. A screw drive **432** is secured inside of the base member **404** and includes a motor **436** that turns a threaded shaft **440** (via a suitable mechanical drive will be easily configured by one skilled in the art based on the packaging requirements of the particular application), and a battery **444** for powering the motor **436**. A traveler **448** having an internally threaded portion receives the threaded shaft **440**. The traveler **448** is generally tubular and has a rectangular exterior profile dimensioned to prevent rotation in the channel defined by the internal walls **428** of the plunger member **408**. A lip **450** on the exterior of the traveler **338** limits insertion into the channel defined by the internal walls **428** as it abuts against the lower edge of the internal walls **428**. A biasing element **452** (which is shown as a helical compression spring and which, for convenience may be referred to as a spring **452**) is fitted inside the end of the traveler **448** opposite the threaded shaft **440**. A magnetic switch **453** is provided in the breakout mechanism **400** and controls power to the motor **436** from the battery **444**. The magnetic switch **453** is actuatable (i.e. closed) by the presence of a magnet **454** proximate to the housing, as shown in FIG. **24**, thereby powering the screw drive **432**.

FIG. **25** shows the breakout mechanism **400** in a compacted state positioned inside a housing. In the illustrated embodiment, the housing is an egg shell **460**. The egg shell **460** includes a fractureable shell portion **464** secured to an

19

annular shell portion 468. The annular shell portion 468 snap-fits to a base shell portion 472. The traveler 448 is positioned inside the channel created by the internal walls 428 of the plunger member 408 and is positioned at a lower end of the threaded shaft 440. The spring 452 is compressed between a shoulder in the interior of the traveler 448 and an end surface in the channel. The motor 436 is used to drive the screw drive 432 to drive progressively increasing flexure of the spring 452 so as to increase a biasing force exerted by the spring 452 urging the plunger member 408 outward from the base member 404.

FIG. 26 shows the breakout mechanism 400 in an expanded state after activation of the screw drive 432 via placement of a magnet proximate to the egg shell 460 adjacent the motor 436. The screw drive 432 operably exerts a separating force urging the plunger member 408 and the base member 404 apart. Upon sufficient fracturing of the egg shell 460, the spring 452 expands from a compressed state to push apart the broken egg shell 460 abruptly to heighten the realism of the hatching action.

FIG. 27 shows a toy character 500 that includes a breakout mechanism similar to the breakout mechanism 400 shown in FIGS. 24 to 26. The breakout mechanism shown in FIG. 27 has a base member 504 and a plunger member 508 shown in an expanded state. The toy character 500 includes a swiveling wheel assembly 512 that has a pair of wheels 516 that are driven, optionally by the same motor that drives the base member 504 and the plunger member 508 apart. A pair of non-swivelling wheels 520 is attached to the base member 504. The swivelling wheel assembly may be connected to the motor in such a way that the wheel assembly 512 is intermittently rotated by some angle by the motor. This provides somewhat erratic movement to the breakout mechanism 500. This erratic movement can convey a sense of realism to the character during its movement.

Again, the breakout mechanisms described and illustrated herein may be provided a decorative cover to simulate the appearance of any suitable character.

FIGS. 28 to 30 illustrate a housing fracturing mechanism 600 according to an embodiment. The housing fracturing mechanism 600 has a base frame member 604 that includes an outer bowl 608 secured to an inner bowl 612. The outer bowl 608 has an inner lip 616 about its top periphery. An upper frame member 620 is rotatably coupled to the base frame member 604 about the top periphery of the outer bowl 608. An inner lip 624 of the upper frame member 620 securely receives the inner lip 616 of the outer bowl 608. Three cutting elements 628 are pivotally coupled at a first end thereof to the base frame member 604 via a fastener such as a partially threaded screw 632. A second end 636 of the cutting elements 628 is slidably coupled to the upper frame member 620 via their protrusion through openings 640 in a side wall of the upper frame member 620. The cutting elements 628 are somewhat arcuate in shape and define an aperture 644 into which a housing 648 to be fractured may be positioned.

As will be understood, rotation of the upper frame member 620 in a counter-clockwise direction relative to the base frame member 604 causes the cutting elements 628 to pivot and intersect/constrict the aperture 644 like an analog camera aperture. Sharp protrusions 652 along the cutting elements 628 project towards the aperture 644 and act to puncture and/or crack the housing 648. In this manner, the housing 648 placed in the housing fracturing mechanism 600 may be fractured.

As will be understood, the cutting elements can be slidably connected to the upper frame member via a number of

20

ways, such as by having a channel therein into which is secured a fastener fastened to the upper frame member. Further, the cutting elements may be pivotally connected to the upper frame member and slidably connected to the base frame member.

One or more cutting elements can be employed and can act to compress the housing to be fractured against other cutting elements or against a portion of the frames.

FIGS. 31A and 31B illustrate a housing fracturing mechanism 700 in accordance with another embodiment. The housing fracturing mechanism 700 includes a pair of cutting elements 704 that are pivotally coupled via a fastener 708, such as a bolt or rivet. One or both of the cutting elements 704 has a recess 712 in a cutting edge 716 thereof. A housing to be broken can be placed in the one or more recesses 712 and can be broken via pivoting of the cutting elements 704, as shown in FIG. 31B, thereby permitting access to the toy character provided in the housing.

Toy characters employing the breakout mechanisms described above, particularly those illustrated in FIGS. 20 to 23 and 24 to 27, can be used in conjunction with companion toy characters that may or may not be placed inside a housing with the toy characters.

FIG. 32A shows a breakout mechanism 800 for a toy character similar to that of FIG. 27 in an expanded state. The breakout mechanism 800 has a base member 804 that nests within a plunger member 808 in a compacted state and is urged away from the plunger member 808 via a screw drive having a motor to the expanded state shown. Movement of the toy character on a surface is provided by wheels 812 that have a cam profile on them with at least one lobe on each wheel, similar to those shown in FIG. 6). The wheels 812 are driven by the motor.

FIG. 32B shows a companion mechanism 820 for a companion toy character that is placed in a housing with the toy character (employing the breakout mechanism 800 of FIG. 32A). The companion mechanism 820 has a main body 824 and a wheel base 828 that nests within the main body 824, but is biased outwards via an internal helical metal coil spring to an expanded state as shown. The wheel base 828 has a set of wheels 832 enabling movement of the companion mechanism 820 along a surface with minimal pushing.

FIG. 33 shows the breakout mechanism 800 of FIG. 32A and the companion mechanism 820 of FIG. 32B in a stacked compacted state. In the compacted state, the screw drive of the breakout mechanism 800 has not yet been activated to drive the plunger member 808 away from the base member 804. The companion mechanism 820 is also in a compacted state, with the wheel base 828 being held under compression within the main body 824 against the force of the helical metal coil spring. The companion mechanism 820 is atop the plunger member 808 of the breakout mechanism 800.

FIG. 34 is a sectional view of a housing in the form of an egg shell 840 having two toy characters positioned inside. A primary toy character 844 employs the breakout mechanism 800, which is in a compacted state. An ancillary toy character 848 employs the companion mechanism 820, which is also in a compacted state. Upon activation of the motor and attached screw drive of the breakout mechanism 800 within the primary toy character 844, such as via a magnet to draw two contacts together to close a circuit, the screw drive urges the plunger member 808 away from the base member 804, causing the breakout mechanism 800 to expand and push the ancillary toy character 848 through the egg shell 840 to fracture it. At the same time, the wheels 812 commence to rotate, and their lobes help push against the interior of the egg shell 840 to fracture it.

Upon its fracturing, the companion mechanism **820** within the toy character **848** is no longer held in compression and the wheel base **828** is urged away from the main body **824** by the helical metal coil spring.

Once the primary toy character **844** is freed from the egg shell **840**, the wheels **812** cause the primary toy character **844** to move across a surface upon which it is placed.

The breakout mechanism **800** and the companion mechanism **820** can include electronic components that are activated upon expansion. In the case of the breakout mechanism **800**, the electronic components can be placed on the same circuit as the motor and be activated upon closing of the circuit. For the companion mechanism **820**, its electronic components may be activated upon the closing of a circuit once the main body **824** and the wheel base **828** are urged apart by the helical metal coil spring.

The electronic components can enable the primary toy character **844** and the ancillary toy character **848** to make audible noises such as bird chirps, display lights, etc. Further, the primary toy character **844** and the ancillary toy character **848** can “interact” through sensing the other. For example, the primary toy character **844** can be equipped with an audio speaker for generating a bird chirping noise, and the ancillary toy character **848** can be equipped with an audio sensor (i.e. a microphone), a processor to discern the bird chirping noise from other audio signals, and an audio speaker to output a corresponding higher-pitched bird chirp. Both the primary toy character **844** and the ancillary toy character **848** can be equipped with sensors, such as microphones, light detectors, network antennas, etc., processors, and output devices, such as audio speakers, light emitting diodes, network radios, etc. In this manner, the primary toy character **844** and the ancillary toy character **848** can interact, with one setting off the other.

In one embodiment, the audio and/or light signals output by an ancillary toy character can be received and used by a primary toy character to locate and move to the ancillary toy character.

FIG. 35 shows another companion mechanism **900** for a smaller ancillary toy character similar to the companion mechanism **820** of FIG. 32B in accordance with another embodiment. The companion mechanism **900** has a main body **904** and a wheel base **908** that nests within the main body **904**, and that is biased outwards via an internal helical metal coil spring to an expanded state as shown. The wheel base **908** has a set of wheels **912** enabling movement of the companion mechanism **900** along a surface with minimal pushing.

FIG. 36 shows a breakout mechanism **920** similar to that of FIG. 32A and two of the companion mechanisms **900** of FIG. 35 in a stacked compacted state. The breakout mechanism **920** has a base member **924** that nests within a plunger member **928** in a compacted state as shown, and is urged away from the plunger member **928** to an expanded state via a screw drive. Movement of the breakout mechanism **920** on a surface is provided by wheels **932** that have a cam profile on them with at least one lobe on each wheel, similar to those shown in FIG. 6).

Each of the two companion mechanisms **900** has its wheel base **908** being held under compression within the main body **904** against the force of the helical metal coil spring. One of the companion mechanisms **900** is positioned atop of the other companion mechanism **900**, which is, in turn, positioned atop the plunger member **928** of the breakout mechanism **920**.

FIG. 37 is a sectional view of a housing in the form of an egg shell **940** having three toy characters positioned inside.

A primary toy character **944** employs the breakout mechanism **920**, which is in a compacted state. Each of two ancillary toy characters **948** employ the companion mechanism **900**, which is also in a compacted state. Upon activation of the screw drive of the breakout mechanism **920** within the primary toy character **944**, such as via a magnet to draw two contacts together to close a circuit, the screw drive urges the plunger member **928** away from the base member **924**, causing the breakout mechanism **920** of the primary toy character **944** to expand and push the toy characters **948** positioned on top through the egg shell **940** to fracture it. Upon its fracturing, the companion mechanism **900** within each of the ancillary toy characters **948** is no longer held in compression and the wheel base **908** is urged away from the main body **904** by the helical metal coil spring.

The primary toy character **944** and the ancillary toy characters **948** can include electronic componentry to provide additional functionality as described above with regards to the primary toy character **844** and the ancillary toy character **848**.

A breakout mechanism can be configured with one or more additional behaviors when the breakout mechanism is placed back in a housing. For example, the breakout mechanism may move, emit audible noises, light up, etc.

FIG. 38 shows an exemplary breakout mechanism **1000** that is configured with additional behaviors when placed in a housing. The housing is an egg shell **1004** that has a raised inner ring **1008**. A small magnet **1012** magnetizes a metal rod **1016** that protrudes from the centre of the bottom inside surface of the egg shell **1004**. An adapter disk **1020** is positioned atop of the raised inner ring **1008** of the egg shell **1004**. The adapter disk **1020** snaps onto the breakout mechanism **1000** and enables movement of the breakout mechanism **1000** relative to the egg shell **1004** as part of an additional behavior. A frustoconical metal disk **1024** is secured to the bottom of the breakout mechanism **1000** to guide placement of the metal rod **1016** to a Hall sensor **1028** inside of the breakout mechanism **1000**. The Hall sensor **1028** senses the magnetism of the metal rod **1016** to detect when the breakout mechanism **1000** is positioned inside of the egg shell **1004**.

FIG. 39 shows a bottom portion of the egg shell **1004** with the raised inner ring **1008** along its inside surface. A crenelated ring **1032** protrudes from the interior surface of the bottom of the egg shell **1004** within the raised inner ring **1008**. A post anchor **1036** inside of the crenelated ring **1032** has an aperture in which the metal rod **1016** is secured.

FIGS. 40A and 40B show the adapter disk **1020** having an annular plate **1040** with a peripheral lip **1044** extending downwards. A pair of wheel recesses **1048a**, **1048b** are dimensioned to receive wheels of the breakout mechanism **1000**. One of the wheel recesses, **1048a**, is deeper than required to receive a wheel of the breakout mechanism **1000**. A disk grip **1052** projects from a bottom surface of the annular plate **1040**. Together, the wheel recess **1048a** and the disk grip **1052** enable a person to pull the adapter disk **1020** off of the breakout mechanism **1000** onto which it snaps so that the wheels of the breakout mechanism **1000** may be exposed and used to mobilize the breakout mechanism **1000** on a surface. A central gear disk **1056** is rotatably coupled to the annular plate **1040** and has a number of gear teeth on its upper surface. Two arcuate walls **1060** extend from a lower surface of the central gear disk **1056**. The arcuate walls **1060** have thickened vertical edges **1064**. A through-hole **1068** enables passage of the metal rod **1016** through the adapter disk **1020**. A pair of securement posts **1072** extend

from the upper surface of the annular plate **1040** to releasably engage corresponding holes in the bottom surface of the breakout mechanism **1000**.

The breakout mechanism **1000** is configured such that, prior to its triggering to fracture the egg shell **1004**, detection of the magnetism of the metal rod **1016** does not trigger the motor of the breakout mechanism **1000**. To trigger the additional behaviors of the breakout mechanism **1000** thereafter, the adapter disk **1020** is secured to the bottom of the breakout mechanism **1000** via the securement posts **1072**, and the combined breakout mechanism **1000** and adapter disk **1020** are placed into the bottom portion of the egg shell **1004**. The arcuate walls **1060** of the adapter disk **1020** fit within the crenelated ring **1032** of the egg shell **1004**, and the thickened vertical edges **1064** engage the crenelated ring **1032** to inhibit rotation of the central gear disk **1056** relative to the egg shell **1004**.

During placement of the breakout mechanism **1000** and the adapter disk **1020**, the metal rod **1016** inserts into the breakout mechanism **1000** guided by the frustoconical metal disk **1024** so that the metal rod **1016** engages the Hall sensor **1028**. The magnetism of the metal rod **1016** is sensed by the Hall sensor **1028** and triggers the motor of the breakout mechanism **1000** to start up.

The breakout mechanism **1000** includes an angled piston arm coupled to the motor that projects from its bottom surface. The motor drives the angled piston arm cycles between extending angularly below the bottom surface of the breakout mechanism **1000** and retracting back into it by its off-center attachment to a rotating disk driven by the motor. On its downward stroke, the angled piston arm engages the gear teeth on the upper surface of the central gear disk **1056** to rotate the breakout mechanism **1000** and annular plate **1040** secured thereto relative to the central gear disk **1056**. On the upward stroke of the angled piston arm, the breakout mechanism **1000** and the annular plate **1040** secured to it remain stationary relative to the egg shell **1004**. As will be understood, continued operation of the motor of the breakout mechanism **1000** causes it to intermittently rotate within the egg shell **1004**.

The motor of the breakout mechanism **1000** can also drive other mechanisms, such as the rotation of extending wing members, providing the illusion that the breakout mechanism **1000** is flapping its wings.

In addition, the Hall sensor **1028** may trigger other elements of the breakout mechanism **1000**. For example, the breakout mechanism **1000** can include one or more of lights, an audio speaker emitting a bird chirp, etc. that can be triggered by the Hall sensor **1028**.

Other types of sensors and mechanisms can be used in place of the Hall sensor to trigger the additional behaviors. For example, the metal rod may complete an electrical circuit to drive the motor when inserted into the breakout mechanism. In a further example, a rod can urge two metal contacts into contact to complete a circuit to drive the motor when inserted into the breakout mechanism.

Movement of the breakout mechanism relative to the housing can be achieved in other manners. For example, a circular track on the inside of the housing can enable the rotation of one wheel to rotate the breakout mechanism relative to the housing.

The dimensions and shape of the recesses, and the materials of the cutting elements can be varied to accommodate housing shapes, materials, and dimensions.

The breakout mechanism and companion mechanisms can be provided with one or more switches to modify their behavior. The switches can take the form of buttons, physi-

cal switches, etc. and can include audio sensors, optical/motion sensors, magnetic sensors, electrical sensors, heat sensors, etc.

In the figures, a toy character has been shown as being provided in the housing. However, it will be noted that the toy character is but one example of an inner object that is provided in the housing. In some embodiments described herein, the inner object may be animate and may include a breakout mechanism. In some embodiments the inner object may not be animate. In some embodiments the inner object may be animate but may not itself include a breakout mechanism. In some embodiments the inner object may be a toy character. In some embodiments, the inner object may not be a character in the sense that it may not be configured to appear as a sentient entity.

Persons skilled in the art will appreciate that there are yet more alternative implementations and modifications possible, and that the above examples are only illustrations of one or more implementations. The scope, therefore, is only to be limited by the claims appended hereto.

What is claimed is:

1. A toy assembly, comprising:

a housing;
an inner object inside the housing, wherein the inner object includes a breakout mechanism that is operable to break the housing to expose the inner object; and
a switch that is actuatable from outside the housing to cause operation of the breakout mechanism,
a rotation mechanism configured to rotate the inner object in the housing; and
a controller configured to operate the rotation mechanism during at least a portion of the operation of the breakout mechanism.

2. A toy assembly as claimed in claim 1, wherein the housing is in the form of an egg.

3. A toy assembly as claimed in claim 2, wherein the inner object is in the form of a bird.

4. A toy assembly as claimed in claim 1, wherein the inner object contains an LED that, when illuminated, is visible through the housing.

5. A toy assembly as claimed in claim 1, wherein the housing has a plurality of irregular fracture paths.

6. A toy assembly as claimed in claim 1, wherein the breakout mechanism includes a hammer and a breakout mechanism power source, wherein the inner object includes at least one release member that can be moved from a pre-breakout position in which the breakout mechanism power source is operatively connected to the hammer to drive the hammer to break the housing, to a post-breakout position in which the breakout mechanism power source is operatively disconnected from the hammer, wherein the at least one release member is in the pre-breakout position prior to breaking of the housing to expose the inner object.

7. A toy assembly as claimed in claim 1, wherein the breakout mechanism further includes a hammer that is movable between a retracted position in which the hammer is spaced from the housing and an extended position in which the hammer is driven to break the housing, an actuation lever, and a breakout mechanism cam, wherein the actuation lever is biased by an actuation lever biasing member towards driving the hammer to the extended position, and wherein the breakout mechanism cam is rotatable by a motor to cyclically cause retraction of the actuation lever from the hammer and then release of the actuation lever to be driven into the hammer by the actuation lever

25

biasing member, wherein the actuation lever biasing member and the motor together make up the breakout mechanism power source.

8. A toy assembly as claimed in claim 7, wherein the actuation lever biasing member is a helical coil tension spring.

9. A toy assembly as claimed in claim 8, wherein, when in the pre-breakout position, the at least one release member releasably connects a first end of the spring to one of the housing and an actuation lever that is pivotable to engage the hammer, and wherein the spring has a second end that is connected to the other of the housing and the actuation lever, and wherein, when in the post-breakout position the at least one release member disconnects the first end of the spring from said one of the housing and the actuation lever.

10. A toy assembly as claimed in claim 1, wherein the inner object further includes at least one limb and a limb power source, wherein, when the inner object is in the pre-breakout position, the limb power source is operatively disconnected from the at least one limb, and wherein, when the inner object is in the post-breakout position the limb power source is operatively connected to the at least one limb.

11. A toy assembly as claimed in claim 10, wherein, when the inner object is in the pre-breakout position, the at least one limb is retained in a non-functional position in which the limb power source does not drive movement of the at least

26

one limb, and wherein, when the inner object is in the post-breakout position the limb power source drives movement of the at least one limb.

12. A toy assembly, comprising:

a housing;

an inner object inside the housing;

a breakout mechanism that is associated with the housing and that is operable to break the housing to expose the inner object; and

a breakout mechanism power source that is associated with the housing,

wherein the breakout mechanism includes a portion of the inner object, and wherein the breakout mechanism power source includes a motor that is operatively connected to the portion of the inner object to drive the portion of the inner object to break the housing.

13. A toy assembly as claimed in claim 12, wherein the breakout mechanism is inside the housing.

14. A toy assembly as claimed in claim 12, wherein the breakout mechanism is inside the housing and is operable from outside the housing.

15. A toy assembly as claimed in claim 12, wherein the breakout mechanism power source is operatively connected to the hammer to reciprocate the hammer to break the housing.

* * * * *