



(12) **United States Patent**  
**Eidenschink**

(10) **Patent No.:** **US 9,642,706 B2**  
(45) **Date of Patent:** **May 9, 2017**

(54) **APPARATUS AND METHOD FOR HEART VALVE REPAIR**

(71) Applicant: **St. Jude Medical, Inc.**, St. Paul, MN (US)

(72) Inventor: **Tracee Eidenschink**, Wayzata, MN (US)

(73) Assignee: **St. Jude Medical, LLC**, Abbott Park, IL (US)

(\* ) Notice: Subject to any disclaimer, the term of this patent is extended or adjusted under 35 U.S.C. 154(b) by 408 days.

(21) Appl. No.: **14/195,355**

(22) Filed: **Mar. 3, 2014**

(65) **Prior Publication Data**  
US 2014/0257347 A1 Sep. 11, 2014

**Related U.S. Application Data**

(60) Provisional application No. 61/776,470, filed on Mar. 11, 2013.

(51) **Int. Cl.**  
*A61F 2/24* (2006.01)  
*A61B 17/128* (2006.01)  
*A61B 17/122* (2006.01)

(52) **U.S. Cl.**  
CPC ..... *A61F 2/2466* (2013.01); *A61F 2/246* (2013.01); *A61B 17/122* (2013.01); *A61B 17/128* (2013.01)

(58) **Field of Classification Search**  
CPC ..... *A61F 2/246*; *A61F 2/2466*; *A61B 17/122*; *A61B 17/128*; *A61B 17/00234*  
See application file for complete search history.

(56) **References Cited**

U.S. PATENT DOCUMENTS

5,156,608 A 10/1992 Troidl et al.  
5,499,991 A \* 3/1996 Garman ..... A61B 17/0483  
606/148

(Continued)

FOREIGN PATENT DOCUMENTS

AU 2002300522 B2 1/2007  
WO 9620749 A1 7/1996

(Continued)

OTHER PUBLICATIONS

Merriam-Webster definition of "fabric" as accessed on Dec. 17, 2014; <http://www.merriam-webster.com/dictionary/fabric>.

(Continued)

*Primary Examiner* — Jing Ou

(74) *Attorney, Agent, or Firm* — Lerner, David, Littenberg, Krumholz & Mentlik, LLP

(57) **ABSTRACT**

A device for transcatheter gathering of tissue of a heart valve leaflet may include an elongated tube extending in a longitudinal direction and having an open distal end, a tissue securing component disposed at the distal end of the elongated tube, and a capture tool movable in the elongated tube between a retracted position and an extended position. The elongated tube may have an inner surface and a lumen extending therethrough. The tissue securing component may include a clip having a roller and a support element. The roller may be rotatable relative to the support element. The capture tool may be operable to capture tissue of the heart valve leaflet and to draw the captured tissue into the tissue securing component. The tissue securing component may be adapted to be applied to the captured tissue to hold the captured tissue in a gathered configuration.

**20 Claims, 5 Drawing Sheets**

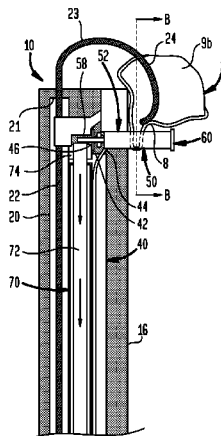

(56)

References Cited

U.S. PATENT DOCUMENTS

5,601,573 A 2/1997 Fogelberg et al.  
 5,741,278 A \* 4/1998 Stevens ..... A61B 17/12013  
 606/139  
 5,749,879 A 5/1998 Middleman et al.  
 5,921,993 A 7/1999 Yoon  
 6,258,105 B1 7/2001 Hart et al.  
 6,440,152 B1 8/2002 Gainor et al.  
 6,569,182 B1 5/2003 Balceita et al.  
 6,626,930 B1 9/2003 Allen et al.  
 6,752,813 B2 6/2004 Goldfarb et al.  
 6,945,978 B1 9/2005 Hyde  
 7,011,669 B2 3/2006 Kimblad  
 7,464,712 B2 12/2008 Oz et al.  
 7,569,062 B1 8/2009 Kuehn et al.  
 7,758,595 B2 7/2010 Allen et al.  
 8,777,966 B2 7/2014 Dale et al.  
 8,951,285 B2 2/2015 Sugimoto et al.  
 2001/0016750 A1 8/2001 Malecki et al.  
 2002/0010388 A1 \* 1/2002 Taylor ..... A61B 17/00234  
 600/204  
 2002/0013571 A1 1/2002 Goldfarb et al.  
 2002/0035390 A1 \* 3/2002 Schaldach ..... A61F 2/958  
 623/1.11  
 2002/0049457 A1 \* 4/2002 Kaplan ..... A61B 17/12  
 606/139  
 2002/0107531 A1 8/2002 Schreck et al.  
 2002/0183768 A1 \* 12/2002 Deem ..... A61B 17/064  
 606/151  
 2003/0065335 A1 \* 4/2003 Guido ..... A61B 17/12013  
 606/144  
 2003/0093071 A1 5/2003 Hauck et al.  
 2003/0120264 A1 6/2003 Lattouf  
 2004/0030335 A1 \* 2/2004 Zenati ..... A61B 17/12013  
 606/51  
 2004/0039442 A1 2/2004 St. Goar et al.  
 2004/0087985 A1 5/2004 Loshakove et al.  
 2004/0176784 A1 \* 9/2004 Okada ..... A61B 17/1285  
 606/142  
 2004/0181238 A1 9/2004 Zarbatany et al.  
 2004/0193185 A1 9/2004 McBrayer  
 2005/0004583 A1 1/2005 Oz et al.  
 2005/0090837 A1 4/2005 Sixto et al.  
 2005/0096671 A1 5/2005 Wellman et al.  
 2005/0107871 A1 5/2005 Realyvasquez et al.  
 2005/0125011 A1 6/2005 Spence et al.  
 2005/0143763 A1 6/2005 Ortiz et al.  
 2005/0149072 A1 7/2005 DeVries et al.  
 2005/0177176 A1 8/2005 Gerbi et al.  
 2005/0251161 A1 11/2005 Saadat et al.  
 2006/0089671 A1 4/2006 Goldfarb et al.  
 2006/0122633 A1 6/2006 To et al.  
 2006/0173422 A1 8/2006 Reydel et al.  
 2006/0173473 A1 \* 8/2006 Bob ..... A61B 1/00151  
 606/153  
 2007/0049952 A1 3/2007 Weiss  
 2007/0093857 A1 4/2007 Rogers et al.  
 2007/0102474 A1 5/2007 Shelton et al.  
 2007/0102475 A1 5/2007 Ortiz et al.  
 2007/0142846 A1 6/2007 Catanese et al.  
 2007/0162056 A1 7/2007 Gerbi et al.  
 2007/0197858 A1 8/2007 Goldfarb et al.  
 2007/0198032 A1 8/2007 Ortiz  
 2007/0225734 A1 9/2007 Bell et al.  
 2008/0125796 A1 5/2008 Graham  
 2008/0234705 A1 9/2008 Cropper et al.

2008/0255427 A1 10/2008 Satake et al.  
 2008/0294175 A1 11/2008 Bardsley et al.  
 2008/0300624 A1 12/2008 Schwemberger et al.  
 2008/0319455 A1 12/2008 Harris et al.  
 2009/0062852 A1 3/2009 Marino  
 2009/0118744 A1 5/2009 Wells et al.  
 2009/0125038 A1 5/2009 Ewers et al.  
 2009/0149870 A1 6/2009 Jugenheimer et al.  
 2011/0054521 A1 3/2011 Ventura et al.  
 2011/0077668 A1 3/2011 Gordon et al.  
 2011/0087242 A1 4/2011 Pribanic et al.  
 2011/0114700 A1 5/2011 Baxter, III et al.  
 2011/0230897 A1 9/2011 Palermo et al.  
 2011/0313432 A1 12/2011 Miles et al.  
 2012/0022532 A1 \* 1/2012 Garrison ..... A61B 18/14  
 606/52  
 2012/0109159 A1 \* 5/2012 Jordan ..... A61B 17/1285  
 606/142  
 2012/0226291 A1 9/2012 Malizia et al.  
 2013/0046332 A1 2/2013 Jones et al.  
 2014/0039607 A1 2/2014 Kovach

FOREIGN PATENT DOCUMENTS

WO 9900059 A1 1/1999  
 WO 0128432 A1 4/2001  
 WO 0139672 A2 6/2001  
 WO 0182847 A2 11/2001  
 WO 0200121 A1 1/2002  
 WO 03049619 A2 6/2003  
 WO 2006039199 A2 4/2006  
 WO 2007027451 A2 3/2007  
 WO 2008068756 A2 6/2008  
 WO 2008121738 A2 10/2008  
 WO 2009087592 A2 7/2009  
 WO 2010094896 A1 8/2010  
 WO 2011053673 A1 5/2011  
 WO 2012087724 A1 6/2012  
 WO 2012106398 A1 8/2012  
 WO 2013019415 A1 2/2013  
 WO 2013116617 A1 8/2013  
 WO 2014022464 A1 2/2014

OTHER PUBLICATIONS

International Search Report for Application No. PCT/US2012/023437 dated Apr. 24, 2012.  
 International Search Report and Written Opinion for Application No. PCT/US2013/052843 dated Oct. 11, 2013.  
 International Search Report and Written Opinion for Application No. PCT/US2013/052838 dated Oct. 11, 2013.  
 International Search Report and Written Opinion for Application No. PCT/US2013/052822 dated Jan. 21, 2014.  
 International Preliminary Report on Patentability for Application No. PCT/US2012/023437 dated Aug. 6, 2013.  
 International Search Report for Application No. PCT/US2013/023077 dated May 14, 2013.  
 International Search Report and Written Opinion for Application No. PCT/US2013/023082 dated Oct. 1, 2013.  
 International Search Report and Written Opinion for Application No. PCT/US2013/024304 dated Jul. 5, 2013.  
 International Search Report for Application No. PCT/US2013/052832 dated Jan. 15, 2014.  
 International Search Report and Written Opinion for Application No. PCT/US2013/065360 dated Apr. 23, 2014.

\* cited by examiner

FIG. 1

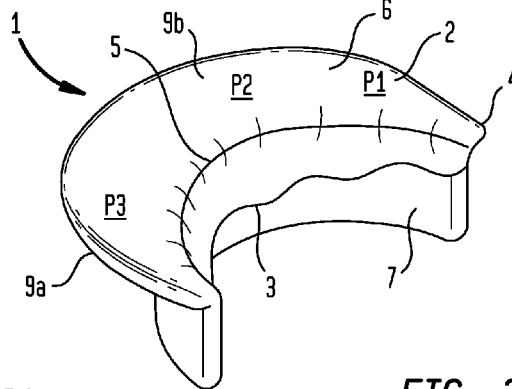

FIG. 2A

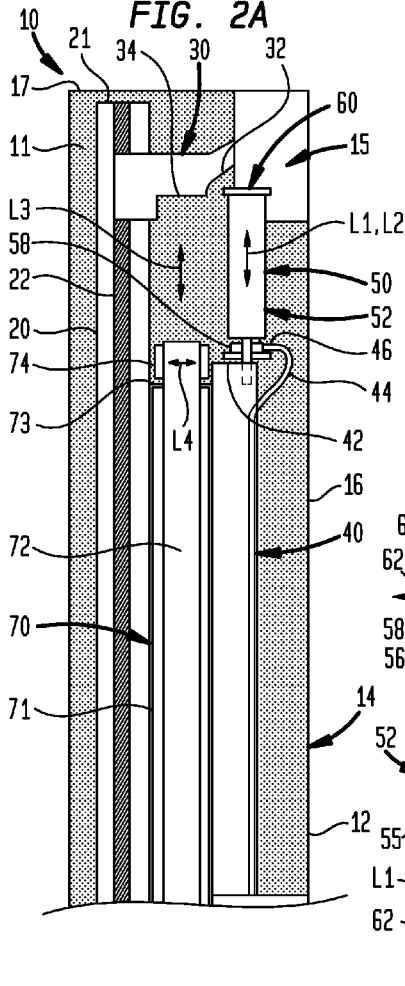

FIG. 2B

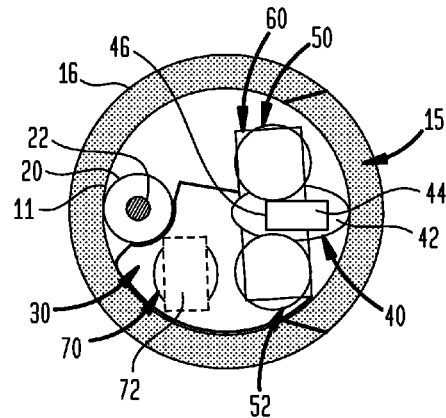

FIG. 2C

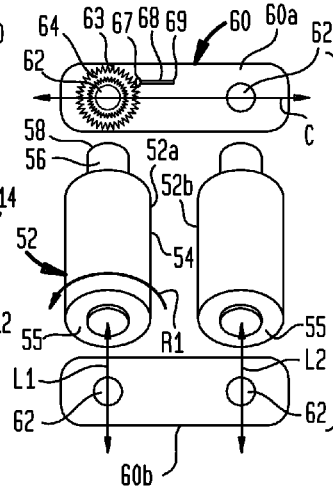

FIG. 2D

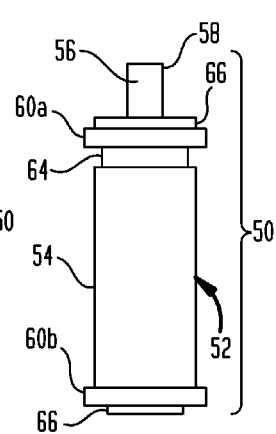

FIG. 3

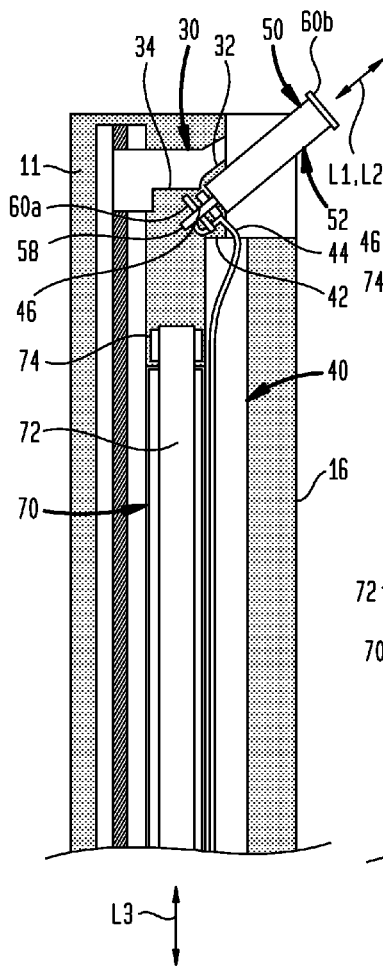

FIG. 4A

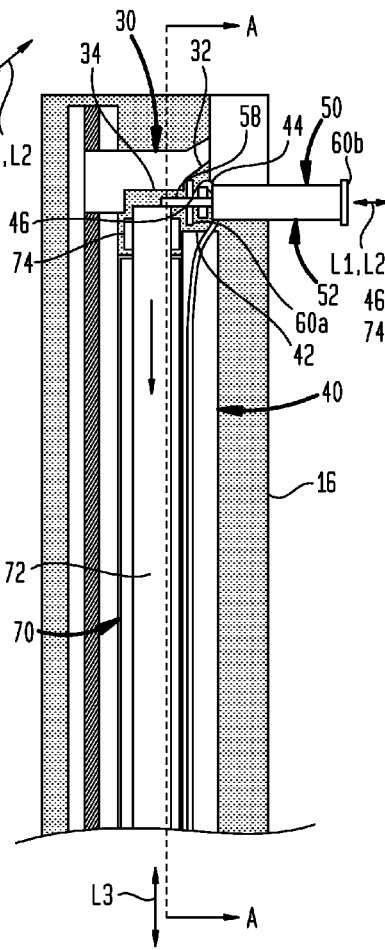

FIG. 4B

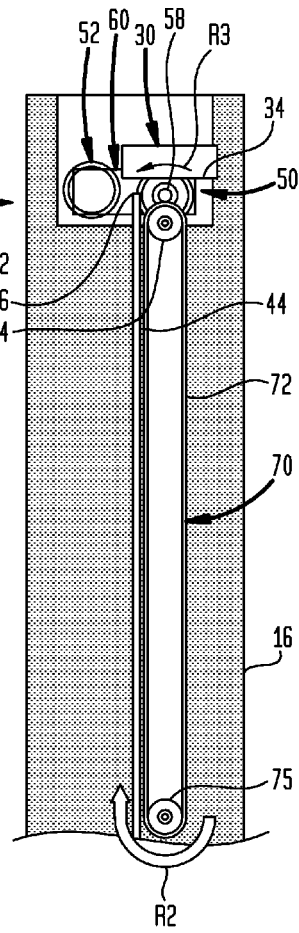

FIG. 5A

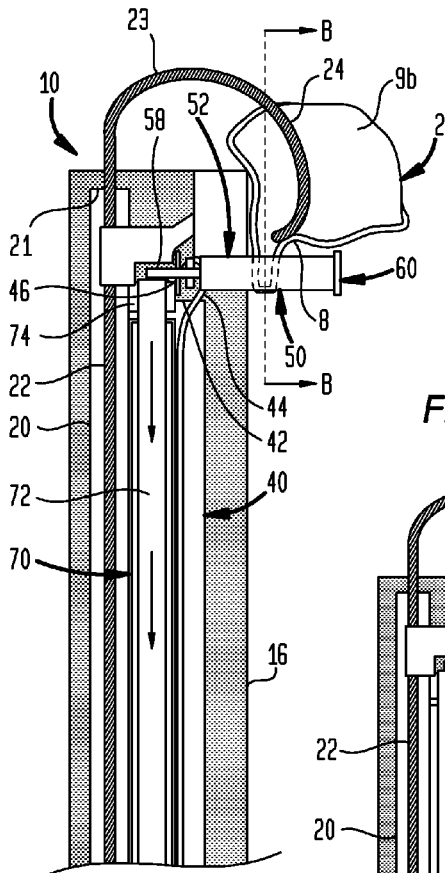

FIG. 5B

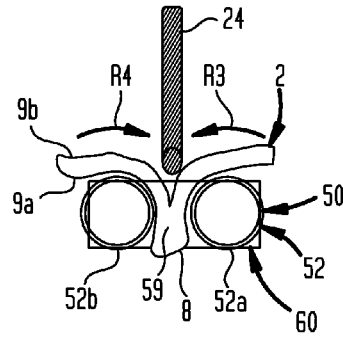

FIG. 6

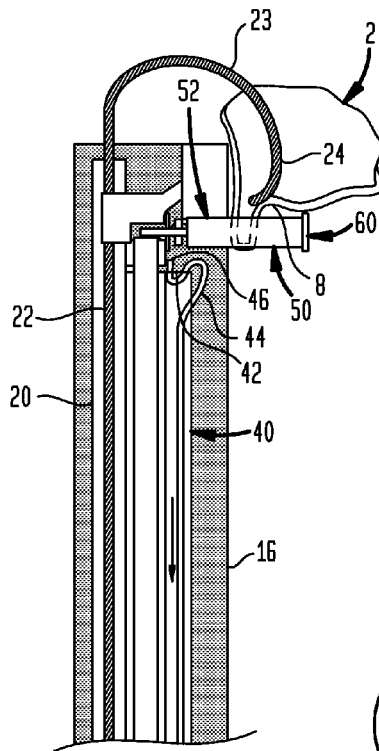

FIG. 7A

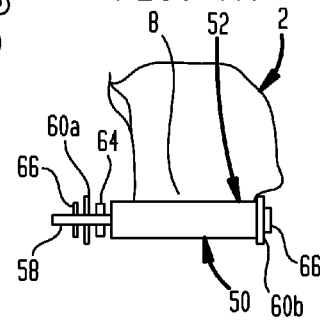
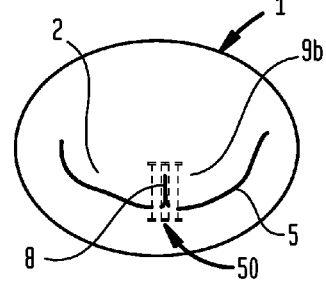
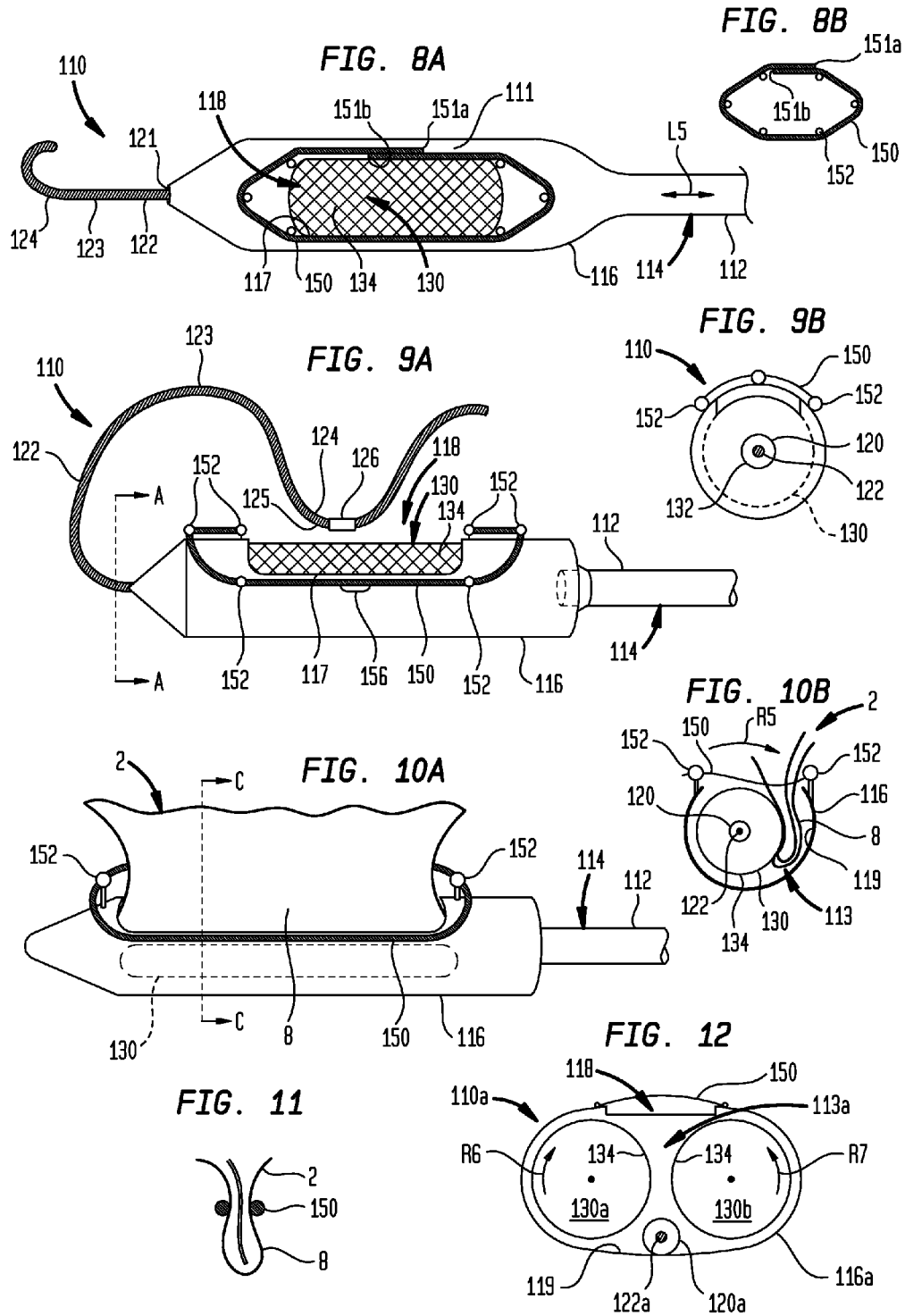
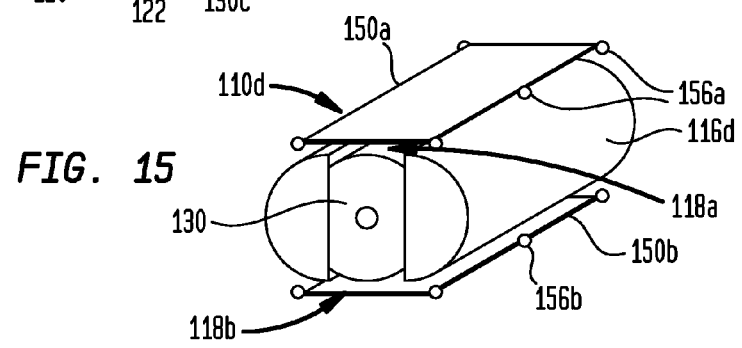
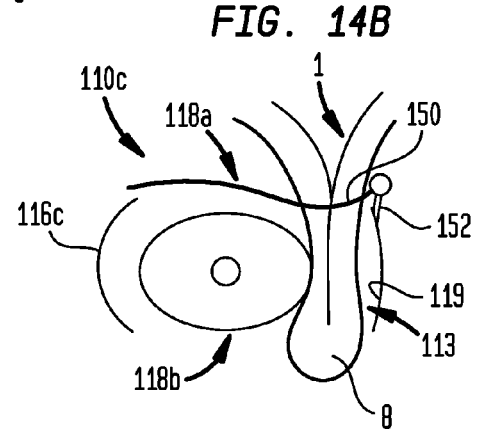
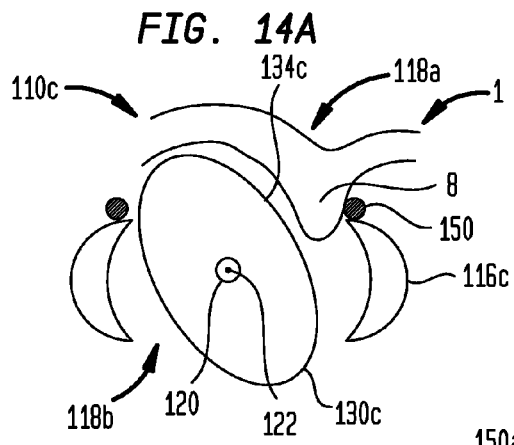
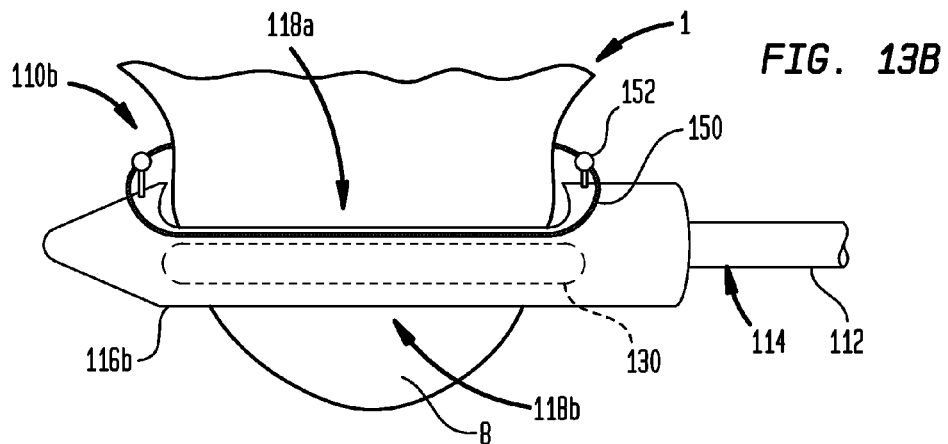
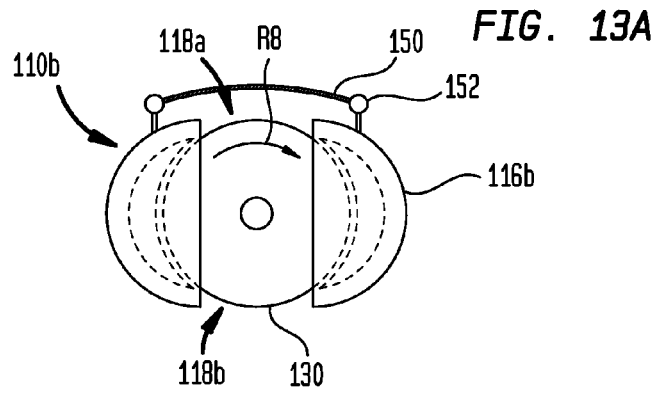

FIG. 7B







1

## APPARATUS AND METHOD FOR HEART VALVE REPAIR

### CROSS-REFERENCE TO RELATED APPLICATION

The present application claims the benefit of the filing date of U.S. Provisional Patent Application No. 61/776,470 filed Mar. 11, 2013, the disclosure of which is hereby incorporated herein by reference.

### BACKGROUND OF THE INVENTION

The present invention is related to heart valve repair, and more particularly to devices, systems, and methods for transcatheter repair of a heart valve leaflet.

Properly functioning heart valves can maintain unidirectional blood flow in the circulatory system by opening and closing, depending on the difference in pressure on each side of the valve. The two atrioventricular valves (mitral and tricuspid valves) are multicusped valves that prevent backflow from the ventricles into the atria during systole. They are anchored to the wall of the ventricle by chordae tendineae, which prevent the valve from inverting.

The mitral valve is located at the gate of the left ventricle and is made up of two leaflets and a diaphanous incomplete ring around the valve, known as the mitral valve annulus. When the valve opens, blood flows into the left ventricle. After the left ventricle fills with blood and contracts, the two leaflets of the mitral valve are pushed upwards and close, preventing blood from flowing back into the left atrium and the lungs.

Mitral valve prolapse is a type of myxomatous valve disease in which the abnormal mitral valve leaflets prolapse (i.e., a portion of the affected leaflet may be billowed, loose, and floppy). Furthermore, the chordae tendineae may stretch and thus become too long, or the chordae tendineae may be broken. As a result, the valve does not close normally, and the unsupported valve leaflet may bulge back, or "prolapse," into the left atrium like a parachute. Thus, as the ventricle contracts, the abnormal leaflet may be propelled backwards, beyond its normal closure line into the left atrium, thereby allowing blood to flow back into the left atrium and the lungs.

Mitral valve prolapse causes mitral regurgitation. Isolated posterior leaflet prolapse of the human heart mitral valve, i.e. prolapse of a single leaflet, is the most common cause of mitral regurgitation. The exact cause of the prolapse is not clear. Untreated mitral regurgitation may lead to congestive heart failure and pulmonary hypertension.

Despite the various improvements that have been made to devices and methods for mitral valve leaflet repair, there remain some shortcomings. For example, conventional methods of treating mitral valve prolapse include replacement of the mitral valve, clipping the two mitral valve leaflets to one another, and resection of the prolapsed segment using open heart surgery. Such surgical methods may be invasive to the patient and may require an extended recovery period.

There therefore is a need for further improvements to the current techniques for treating heart valve leaflet prolapse. Among other advantages, the present invention may address one or more of these needs.

### BRIEF SUMMARY OF THE INVENTION

Devices and methods for gathering of heart valve leaflet tissue are disclosed. A device for transcatheter gathering of

2

tissue of a heart valve leaflet may include an elongated tube extending in a longitudinal direction and having an open distal end, a tissue securing component disposed at the distal end of the elongated tube, and a capture tool movable in the elongated tube between a retracted position and an extended position. The elongated tube may have an inner surface and a lumen extending therethrough. The tissue securing component may include a clip having a roller and a support element. The roller may be rotatable relative to the support element. The capture tool may be operable to capture tissue of the heart valve leaflet and to draw the captured tissue into the tissue securing component. The tissue securing component may be adapted to be applied to the captured tissue to hold the captured tissue in a gathered configuration.

The roller may be a first roller and the support element may be a second roller. The second roller may be rotatable relative to the first roller. The second roller may be fixed relative to a rotational axis of the first roller. The support element may be fixed relative to a rotational axis of the roller. The tissue securing component may include a mechanism permitting rotation of the roller about a rotational axis of the roller only in a first rotational direction. The mechanism may prevent rotation of the roller in a second rotational direction opposite the first rotational direction. The tissue securing component may include two coupling plates extending between the roller and the support element. The roller may have an outer surface that is roughened, knurled, or having features that protrude from the outer surface.

The device may also include a drive assembly adapted to rotate the roller relative to the support element. The drive assembly may be movable in the elongated tube in the longitudinal direction. The drive assembly may be movable to a proximal position in which a distal end of the drive assembly is spaced apart from the roller and a distal position in which the distal end of the drive assembly contacts a portion of the roller. The drive assembly may include a belt extending around two rollers. The device may also include an actuation shaft movable in the elongated tube in the longitudinal direction. The actuation shaft may be adapted to move the tissue securing component therewith relative to the elongated tube.

The device may also include a contact plate having a guide surface disposed at an oblique angle relative to the longitudinal direction. The guide surface may be adapted to guide motion of the tissue securing component such that the roller pivots relative to the actuation shaft about an axis perpendicular to a rotational axis of the roller when the actuation shaft is moved distally. The device may also include a release wire removably coupled to the tissue securing component and extending through the elongated tube to a proximal end of the device. A distal end of the capture tool may have a hook shape. The capture tool may include a grasping wire slidably disposed in a containment tube. A distal portion of the grasping wire may be adapted to change from a linear shape to the hook shape when the distal portion of the grasping wire is extended out from the containment tube. The grasping wire may be partially or entirely made from a shape-memory material.

A transcatheter method of gathering tissue of a heart valve leaflet may include inserting a catheter assembly to a position adjacent the heart valve leaflet. The catheter assembly may include an elongated tube extending in a longitudinal direction and having an open distal end, a capture tool moveable between a retracted position and an extended position, and a tissue securing component including a roller and a support element. The method may also include moving the capture tool from the retracted position toward the



3

extended position and manipulating the capture tool so that tissue of the heart valve leaflet is captured by the capture tool. The method may also include drawing the captured tissue between the roller and the support element by moving the capture tool to the extended position and rotating the roller in a first rotational direction to push the captured tissue through a gap located between the roller and the support element. The method may also include securing the captured tissue by preventing rotation of the roller in a second rotational direction opposite the first rotational direction to hold the captured tissue substantially in a gathered configuration.

The method may also include, after the securing step, detaching a release wire from the tissue securing component. The release wire may extend through the elongated tube to a proximal end of the device. The method may also include, before the rotating step, advancing the roller distally relative to the elongated tube in the longitudinal direction. The method may also include, before the rotating step, pivoting the roller relative to the elongated tube from a first orientation in which a rotational axis of the roller is oriented substantially parallel to the longitudinal direction to a second orientation in which the rotational axis of the roller is oriented substantially perpendicular to the longitudinal direction. The pivoting step may be performed by advancing the roller distally relative to the elongated tube in the longitudinal direction until the roller contacts a guide surface disposed at an oblique angle relative to the longitudinal direction. The contact with the guide surface may cause the roller to pivot relative to the elongated tube about an axis perpendicular to the rotational axis of the roller.

During the securing step, the rotation of the roller in the second rotational direction may be prevented by interaction of a spring lock member and teeth of a ratcheting cam affixed to the first roller and adapted to rotate therewith relative to the spring lock member. The rotating step may be performed by actuating a drive assembly in contact with the tissue securing component. The method may also include, before the rotating step, moving the drive assembly from an initial position in which a distal end of the drive assembly is spaced apart from the roller and an engaged position in which the distal end of the drive assembly contacts a portion of the roller.

The roller is a first roller and the support element may be a second roller. The second roller may be rotatable relative to the first roller. The rotating step may include rotating the second roller in the second rotational direction. During the rotating step, the rotation of the second roller may be caused by friction between the captured tissue and the first and second rollers, such that the rotation of the first roller in the first rotational direction forces the second roller to rotate in the second rotational direction. The capture tool may include a grasping wire slidably disposed in a containment tube. The moving step may be performed by sliding a distal end of the grasping wire out of the containment tube so that the distal portion of the grasping wire changes from a linear shape to a hook shape.

Another device for transcatheter gathering of tissue of a heart valve leaflet may include an elongated tube extending in a longitudinal direction and having an opening extending generally in the longitudinal direction and partially around a circumference of the elongated tube, a capture tool movable in the elongated tube between a retracted position and an extended position, a roller extending within the elongated tube and being rotatable relative to the elongated tube, and a tissue securing component disposed around a peripheral edge of the opening. The elongated tube may have a lumen

4

therein defining an inner surface. The capture tool may be operable to capture tissue of the heart valve leaflet and to draw the captured tissue into the opening. The roller may be located adjacent the opening and may have a rotational axis substantially parallel to the longitudinal direction. The roller may define an outer surface spaced apart from the inner surface of the elongated tube. The roller may be operable to gather the captured tissue into a pocket within the elongated tube formed adjacent the outer surface of the roller. The tissue securing component may be adapted to be applied to the captured tissue to hold the captured tissue in a gathered configuration.

The opening may be a first opening. The elongated tube may have a second opening extending generally in the longitudinal direction and partially around the circumference of the elongated tube. The second opening may be located opposite the first opening in a direction perpendicular to the longitudinal direction. The roller may be operable to gather the captured tissue into the pocket and through the second opening. The tissue securing component may be a first tissue securing component. The device may also include a second tissue securing component disposed around a peripheral edge of the second opening and adapted to be applied to the captured tissue to hold the captured tissue in the gathered configuration. The outer surface of the roller may be roughened, knurled, or having features that protrude from the outer surface.

The roller may have a circular cross-sectional shape in a direction perpendicular to the rotational axis of the roller. The roller may have an oblong cross-sectional shape in a direction perpendicular to the rotational axis of the roller. The pocket may extend between the outer surface of the roller and the inner surface of the elongated tube. The tissue securing component may be a releasable clip configured to be held in an expanded condition around the peripheral edge of the opening until the clip is released. The clip may have one or more radiopaque markers thereon. The device may also include retention posts disposed around the peripheral edge of the opening. The retention posts may extend from an outer surface of the elongated tube in a direction substantially perpendicular to the outer surface. The clip may extend around the retention posts in the expanded condition and may be biased from the expanded condition to a clamping condition.

The retention posts may be retractable into the outer tube. The clip may be released from the retention posts when the retention posts are retracted into the outer tube. A distal end of the capture tool may have a hook shape. The capture tool may include a grasping wire slidably disposed in a lumen extending through the roller in the longitudinal direction. A distal portion of the grasping wire may be adapted to change from a linear shape to the hook shape when the distal portion of the grasping wire is extended out from the lumen. The grasping wire may be partially or entirely made from a shape-memory material. The grasping wire may have one or more radiopaque markers thereon. The roller may be a first roller. The device may also include a second roller extending within the elongated tube adjacent the first roller and being rotatable relative to the first roller. The second roller may have a rotational axis substantially parallel to the longitudinal direction. The pocket may extend between the first and second rollers.

Another transcatheter method of gathering tissue of a heart valve leaflet may include inserting a catheter assembly to a position adjacent the heart valve leaflet. The catheter assembly may include an elongated tube extending in a longitudinal direction, a capture tool moveable between a

5

retracted position and an extended position, a roller extending within the elongated tube and located adjacent an opening of the elongated tube, and a tissue securing component disposed around a peripheral edge of the opening. The method may also include moving the capture tool from the retracted position toward the extended position and manipulating the capture tool so that tissue of the heart valve leaflet is captured by the capture tool. The method may also include drawing the captured tissue into the opening by moving the capture tool to the extended position and rotating the roller in a first rotational direction to push the captured tissue into a pocket within the elongated tube formed adjacent the outer surface of the roller. The method may also include securing the captured tissue by releasing the tissue securing component from the catheter assembly to the captured tissue so as to hold the captured tissue substantially in a gathered configuration.

The tissue securing component may be a releasable clip. During the inserting step, the clip may be held in an expanded condition around retention posts located around the peripheral edge of the opening. The securing step may be performed by retracting the retention posts into the outer tube. The clip may be released from the retention posts onto the captured tissue. The opening may be a first opening. The elongated tube may have a second opening located opposite the first opening in a direction perpendicular to the longitudinal direction. The rotating step may push the captured tissue into the pocket and through the second opening. The capture tool may include a grasping wire slidably disposed in a containment tube. The moving step may be performed by sliding a distal end of the grasping wire out of the containment tube so that the distal portion of the grasping wire changes from a linear shape to a hook shape.

The method may also include, after the securing step, releasing the captured tissue by rotating the roller in a second rotational direction opposite the first rotational direction to push the captured tissue out of the opening. The roller may be a first roller and the support element may be a second roller. The second roller may be rotatable relative to the first roller. The rotating step may include rotating the second roller in a second rotational direction opposite the first rotational direction. The pocket may be a gap extending between the first and second rollers. During the rotating step, the rotation of the second roller may be caused by friction between the captured tissue and the first and second rollers. Rotation of the first roller in the first rotational direction may force the second roller to rotate in the second rotational direction.

Yet another device for transcatheter gathering of tissue of a heart valve leaflet may include an elongated tube extending in a longitudinal direction and having an opening therein, a tissue gathering component disposed within the elongated tube adjacent the opening, and a capture tool movable in the elongated tube between a retracted position and an extended position. The tissue gathering component may include a roller and a support element. The capture tool may be operable to capture tissue of the heart valve leaflet and to draw the captured tissue into the tissue gathering component. The tissue gathering component may be adapted to gather the captured tissue between the roller and the support element when in an operating position.

The roller may be a first roller. The support element may comprise a second roller. The tissue gathering component may be adapted to be secured to the captured tissue to hold the captured tissue in a gathered configuration. The support element may comprise an inner surface of the elongated tube. The device may also include a tissue securing com-

6

ponent disposed around a peripheral edge of the opening and adapted to be applied to the captured tissue to hold the captured tissue in a gathered configuration.

## BRIEF DESCRIPTION OF THE DRAWINGS

Various embodiments of the present invention will now be discussed with reference to the appended drawings. It is appreciated that these drawings depict only some embodiments of the invention and are therefore not to be considered limiting of its scope.

FIG. 1 is a diagrammatic perspective view of the posterior leaflet of a mitral valve;

FIG. 2A is a diagrammatic longitudinal cross-sectional view of the distal portion of one embodiment of a device for transcatheter gathering of heart valve leaflet tissue, shown with the clip in an initial position;

FIG. 2B is a top plan view of the distal portion of the device of FIG. 2A;

FIG. 2C is an exploded perspective view of the clip of FIG. 2A;

FIG. 2D is a side view of the clip of FIG. 2A;

FIG. 3 is a longitudinal cross-sectional view of the distal portion of the device of FIG. 2A, shown with the clip in an intermediate position;

FIG. 4A is a longitudinal cross-sectional view of the distal portion of the device of FIG. 2A, shown with the clip in a use position;

FIG. 4B is a longitudinal cross-sectional view of the distal portion of the device of FIG. 4A, taken along the line A-A of FIG. 4A;

FIG. 5A is a longitudinal cross-sectional view of the distal portion of the device of FIG. 2A, engaged with the posterior leaflet of the mitral valve of FIG. 1;

FIG. 5B is a side cross-sectional view of the clip of FIG. 5A, engaged with the posterior leaflet of the mitral valve of FIG. 1, taken along the line B-B of FIG. 5A;

FIG. 6 is a longitudinal cross-sectional view of the distal portion of the device of FIG. 2A, shown with the release wire detached from the clip;

FIG. 7A is a side view of the clip of FIG. 2A, engaged with the posterior leaflet of the mitral valve of FIG. 1;

FIG. 7B is a top view of the clip of FIG. 2A, engaged with the posterior leaflet of the mitral valve of FIG. 1;

FIG. 8A is a diagrammatic top view of the distal portion of another embodiment of a device for transcatheter gathering of heart valve leaflet tissue;

FIG. 8B is a diagrammatic view of the clip and retention pegs of FIG. 8A;

FIG. 9A is a side view of the distal portion of the device of FIG. 8A, shown with the hook deployed;

FIG. 9B is an end view of the distal portion of the device of FIG. 8A;

FIG. 10A is a side view of the distal portion of the device of FIG. 8A, engaged with the posterior leaflet of the mitral valve of FIG. 1;

FIG. 10B is a cross-sectional view of the device of FIG. 10A, taken along the line C-C of FIG. 10A;

FIG. 11 is a cross-sectional view of the clip of FIG. 8A, engaged with the posterior leaflet of the mitral valve of FIG. 1;

FIG. 12 is a cross-sectional view of a distal portion of a variant of the device of FIG. 8A according to an alternate embodiment;

FIG. 13A is a cross-sectional view of a distal portion of a variant of the device of FIG. 8A according to another alternate embodiment;

7

FIG. 13B is a side view of the distal portion of the device of FIG. 13A, engaged with the posterior leaflet of the mitral valve of FIG. 1;

FIG. 14A is a cross-sectional view of a distal portion of another variant of the device of FIG. 8A according to yet another alternate embodiment;

FIG. 14B is a cross-sectional view of the device of FIG. 14A, shown with a captured portion of posterior leaflet tissue extending therethrough; and

FIG. 15 is a perspective view of a distal portion of still another variant of the device of FIG. 8A according to another alternate embodiment.

#### DETAILED DESCRIPTION

As used herein, the terms “proximal” and “distal” are to be taken as relative to a user (e.g., a surgeon or an interventional cardiologist) using the disclosed devices. “Proximal” is to be understood as relatively close to the user and “distal” is to be understood as relatively farther away from the user. The invention will be described in connection with the repair of a mitral valve leaflet, but it may be useful in the repair of other types of cardiac valves or in the gathering and clamping of other types of loose body tissue.

Referring to FIG. 1, an exemplary mitral valve 1 includes a posterior leaflet 2 and an anterior leaflet 3. The leaflets 2 and 3 extend from an annulus 4 to a coaption line 5 where the leaflets meet. The posterior leaflet 2 has an upper portion 6 that is generally perpendicular to the direction of blood flow through the valve 1 and extends between the annulus and the coaption line 5. Additionally, the posterior leaflet 2 has a lower portion 7 that is generally parallel to the direction of blood flow through the valve 1 and extends below the coaption line 5. The posterior leaflet 2 also has a lower surface 9a and an upper surface 9b. The posterior leaflet 2 has three scalloped portions P1, P2, and P3, any of which may include a portion that is billowed, loose, or floppy, and which therefore may be the cause of a prolapse condition of the valve. The inventive devices, systems, and methods described herein may be adapted to repair such a billowed, loose, or floppy portion of the posterior leaflet 2 or the anterior leaflet 3.

Referring to FIG. 2A, an exemplary device 10 for transcatheter gathering of heart valve leaflet tissue includes an elongated catheter assembly 12 adapted to be inserted through the apex of a human heart so that a distal portion 14 of the catheter assembly may reach the patient's mitral valve 1 for repair thereof. The catheter assembly 12 includes a containment tube 20 disposed within an outer tube 16. In a particular embodiment, the outer tube 16 may be made of one or more echogenic materials, so that the outer tube may be more easily visualized inside a patient using three-dimensional echocardiography.

The catheter assembly 12 further includes a capture tool in the form of a grasping wire 22 that is longitudinally slidable within the containment tube 20 between a retracted position substantially entirely within the lumen of the containment tube (FIG. 2A), and a deployed position in which a distal portion 23 of the grasping wire protrudes from the distal tip 21 of the containment tube (FIG. 5A). The grasping wire 22 may have a linear configuration when fully retracted within the containment tube 20 and the distal portion 23 thereof may assume the shape of a hook 24 when deployed from the containment tube. In that regard, the grasping wire 22 may be formed from a memory metal or a strong, resilient metal or polymer that will cause the hook 24 to form automatically when deployed.

8

The catheter assembly 12 further includes a tissue securing component in the form of a clip 50 that is adapted to secure tissue of a heart valve leaflet that is captured therein, as will be described below. As can be seen in FIG. 2C, the clip includes two rollers 52a and 52b (collectively, rollers 52). One or both of the rollers 52 may have a smooth outer surface 54, and one or both of the rollers may have a roughened or knurled surface, or a surface with protruding features (e.g., small spikes) that are configured to increase friction or gripping strength between the rollers and tissue of a heart valve leaflet that may be inserted between the rollers.

Each of the rollers 52 may be mounted between coupling plates 60a and 60b (collectively, coupling plates 60) that may be adapted to couple the rollers to one another with sufficient distance between the outer surfaces 54 thereof to permit heart valve leaflet tissue to extend therebetween. Although the embodiment shown in the figures has two coupling plates 60, in other embodiments, the rollers 52 may be coupled to a single coupling plate 60a, such that tissue may be inserted between adjacent ends 55 of the rollers as well as along the outer surfaces 54 of the rollers.

As shown in FIGS. 2C and 2D, each of the rollers 52 may be coupled to the coupling plates 60a and 60b by pins 56 extending through lumens of the rollers and through openings 62 in the coupling plates. Alternatively, separate pins 56 may respectively extend outwardly from each end of the rollers 52, as opposed to the pins extending therethrough. The pins 56 may each be affixed to a corresponding one of the rollers 52 and may be coupled to the coupling plates 60a and 60b by lock washers 66 that are adapted to retain the pins between the coupling plates while permitting one or both of the rollers 52a and 52b to rotate relative to the coupling plates around corresponding longitudinal axes L1 and L2. Each of the pins 56 may extend through the first coupling plate 60a such that an end portion 58 thereof is exposed beyond the coupling plate. Although as shown in the figures, both of the pins 56 have exposed end portions 58, in other embodiments, the second roller 52b may be provided without an exposed end portion, such that only the first roller 52a has an exposed end portion. In one example, one or both of the pins 56 may be formed integrally with or permanently attached to its corresponding roller 52, such that the pin may be considered to be a portion of the roller.

If it is desired that both rollers 52 be free to rotate about their longitudinal axes L1, L2, the pins 56 may both be rotationally coupled to the coupling plates 60. If it is desired that only the first roller 52a be free to rotate about its axis L1, the pin 56 of the first roller may be rotationally coupled to the coupling plates 60, while the pin of the second roller 52b may be affixed to the coupling plates. In a particular example, the second roller 52b may be a support element affixed between the coupling plates 60 that need not be generally in the shape of a cylinder. For example, such a support element could be a beam having a rectangular or arcuate cross-section.

A first one of the rollers 52a may rotate around its longitudinal axis L1 in only one rotational direction R1, for example. In the example shown in the figures, the unidirectional rotation of the first roller 52a may be enabled by interaction between an end 67 of a spring lock member 68 affixed at its base 69 to a first coupling plate 60a and teeth of a ratcheting cam 64. The ratcheting cam 64 may be affixed to the first roller 52a and may be adapted to rotate therewith relative to the spring lock member 68. The spring lock member 68 may be located to one side of a centerline C of the first coupling plate 60a and oriented substantially parallel to the centerline. As shown in FIG. 2C, the spring lock

member **68** may be located above the centerline to enable rotation of the first roller **52a** in a counterclockwise rotational direction **R1** and to disable clockwise rotation thereof. Alternatively, the spring lock member **68** may be located below the centerline to enable clockwise rotation of the first roller **52a** and to disable counterclockwise rotation thereof.

At its distal end **17**, the outer tube **16** has an open side **15** that may provide clearance for the clip **50** to pivot away from the closed side **11** of the outer tube, so that the clip may be positioned to receive heart valve leaflet between the rollers **52** thereof, as will be described below.

The clip **50** may be removably coupled to an actuation shaft **40** that is slidably mounted within the outer tube **16** so that it may move relative to the outer tube along the longitudinal axis **L3** of the outer tube. In its initial position (FIG. 2A), the clip **50** may be supported on a distal end **42** of the actuation shaft **40** so that the clip may be moved distally when the actuation shaft is moved distally. The clip **50** may be removably coupled to the actuation shaft **40** by a release wire **44**, which may be a metal wire or a suture, for example. A distal end **46** of the release wire **44** may be removably attached to the clip **50** at or adjacent the first coupling plate **60a**. A proximal end of the release wire **44** (not shown) may extend through the outer tube **16** to a location where it can be grasped by a user. In its initial position, the clip **50** may be oriented such that the longitudinal axes **L1**, **L2** of the rollers **52** are substantially parallel to a longitudinal axis **L3** of the outer tube **16**.

The catheter assembly **12** further includes a contact plate **30** affixed to the outer tube **16**. The contact plate **30** may have a guide surface **32** and an adjacent support surface **34**. The guide surface **32** may be disposed at an oblique angle relative to the longitudinal axis **L3** of the outer tube **16**. The guide surface **32** may be adapted to guide motion of the clip **50**. The support surface **34** may be disposed substantially perpendicular to the longitudinal axis **L3** and may be adapted to support the exposed end portion **58** of the pin **56** extending through the first roller **52a**, as will be described below.

The catheter assembly **12** may further include a drive assembly **70** that is slidably mounted within the outer tube **16** so that it may move relative to the outer tube along the longitudinal axis **L3** of the outer tube. The drive assembly **70** may be adapted to rotate the first roller **52a** relative to the outer tube about the longitudinal axis **L1** of the first roller. The drive assembly **70** may include a support shaft **71** and a drive belt **72**. The support shaft **71** may optionally have a lumen extending therethrough that is configured to receive the drive belt **72** therein. The drive assembly **70** may also include a drive roller **74** that is coupled to the support shaft **71** but is free to rotate relative to the support shaft about its longitudinal axis **L4**. The longitudinal axis **L4** may be substantially perpendicular to the longitudinal axis **L3** of the outer tube **L3**.

In a particular embodiment (not shown) the drive assembly **70** may be movable relative to the outer tube in a direction that is not substantially parallel to the longitudinal axis **L3** of the outer tube **16**. For example, the drive assembly **70** may be movable between an initial position and an engaged position (in which the drive assembly is engaged with the first roller **52a**) in a direction that is substantially perpendicular to the longitudinal axis **L3** of the outer tube **16**.

The drive belt **72** may be assembled around the drive roller **74** and a support roller **75** (not visible in FIG. 2A, but shown in FIG. 4B) located distally of the drive roller. The support roller **75** may be either directly or indirectly coupled

to the support shaft **71**, and the drive roller may be free to rotate relative to the support shaft about its longitudinal axis. The support roller **75** may be located within the outer tube **16**, and the rotation of the support roller may be actuated by a handle (not shown) at a proximal end of the catheter assembly **12**, or the support roller may be located within such an actuation handle. The drive belt **72** may extend through a lumen of the support shaft **71**, or it may extend along an outer surface of the support shaft. Examples of actuation handles for the devices described herein may be found in International Patent Publication No. WO 2012/106398, which is hereby incorporated by reference herein.

It is preferred that the drive assembly **70** include or be coupled to a torque limiter that is adapted to prevent a user from exceeding a predetermined torque that may damage tissue of the leaflet **2**. Such a torque limiter may include a sensor that can determine the torque experienced by the rollers **52** and a mechanism for stopping the ability of the user to continue to actuate a control handle to actuate the drive assembly **70** if the predetermined maximum torque is reached.

To use the device **10** for transcatheter gathering of heart valve leaflet tissue, the support shaft **71** and the actuation shaft **40** may be initially disposed in their proximal positions shown in FIG. 2A, and the clip **50** may be initially disposed in its initial position shown in FIG. 2A, such that the longitudinal axes **L1** and **L2** of the rollers **52** are oriented substantially parallel to the longitudinal axis **L3** of the outer tube **16**.

Next, the distal portion **14** of the catheter assembly **12** may be inserted into a patient through the apex of the heart, for example, into the left ventricle, so that the distal portion extends between the posterior leaflet **2** and the anterior leaflet **3** of the mitral valve **1**. The distal edge **17** of the outer tube **16** may be disposed near the coaption line **5** of the mitral valve **1**, with the open side **15** of the outer tube facing the posterior leaflet **2**. In a particular embodiment, the distal edge **17** of the outer tube **16** may be guided to a position near the coaption line **5** using the assistance of three-dimensional echocardiography to visualize the outer tube or other components of the catheter assembly **12**.

Then, referring to FIG. 3, the actuation shaft **40** may be moved distally from its proximal position to an intermediate position. As the actuation shaft **40** moves distally relative to the outer tube **16**, the second coupling plate **60b** of the clip **50** may contact the guide surface **32** of the contact plate **30**. When the second coupling plate **60b** contacts the oblique angle of the guide surface **32**, the guide surface will exert a rotational force onto the clip **50**, such that continued distal movement of the actuation shaft **40** will pivot the clip about the first coupling plate **60a** relative to the outer tube. FIG. 3 shows the clip **50** in an intermediate position that is partially pivoted relative to the actuation shaft **40**, such that the longitudinal axes **L1** and **L2** are disposed at an oblique angle relative to the longitudinal axis **L3** of the outer tube **16**, and such that the second coupling plate **60b** moves gradually away from the closed side **11** of the outer tube.

Subsequently, the actuation shaft **40** may continue to be moved distally from its intermediate position to the distal position shown in FIG. 4A. As the actuation shaft **40** continues to move distally relative to the outer tube **16**, the clip continues to pivot about the first coupling plate **60a** until the clip **50** reaches its use position, such that the longitudinal axes **L1** and **L2** are disposed substantially perpendicular to the longitudinal axis **L3** of the outer tube. The pivoting of the clip **50** is eventually stopped by contact between the support

11

surface **34** of the contact plate **30** and the exposed end portion **58** of the pin **56** of the first roller **52a**.

Next, the support shaft **71** of the drive assembly may be moved distally from its initial position to the distal position shown in FIG. 4A. The support shaft **71** may be moved distally until the drive belt **72** contacts the exposed end portion **58** of the pin **56** of the first roller **52a**. As can be seen in FIG. 4B, when the support shaft **71** is in its distal position, the exposed end portion **58** of the pin **56** of the first roller **52a** is located between the support surface **34** of the contact plate **30** and the drive belt **72**. In this position, rotation of the support roller **75** in a rotational direction **R2** will rotate the drive belt **72** and the drive roller **74**, which in turn, will rotate the exposed end portion **58** of the pin **56** of the first roller **52a** in a direction **R3** opposite the direction **R2**.

Then, as can be seen in FIG. 5A, the outer tube **16** can be manipulated by the user such that the rollers **52** at least partially extend underneath a portion of the posterior leaflet **2** of the mitral valve **1** that may be loose or floppy and require tightening. The hook **24** may then be deployed to an extended position by moving the distal portion **23** of the grasping wire **22** distally out of the containment tube **20**. No longer being constrained by the containment tube **20**, the distal portion **23** of the grasping wire **22** may assume the curved shape of the hook **24**. It is preferable that the hook **24** have a curvature when deployed that is sufficient to push a portion of the posterior leaflet **2** against the rollers **52**, as shown in FIG. 5A.

Once the posterior leaflet **2** is pushed against the rollers **52**, the user may actuate the drive assembly **70** to move the drive belt **72**, thereby rotating the first roller **52a** in the rotational direction **R3** and rotating the second roller **52b** in a rotational direction **R4** opposite the direction **R3** (or, only rotating the first roller in the direction **R3** in an embodiment where the second roller is rotationally fixed). The rotation of the rollers **52** as the posterior leaflet **2** is pushed against the rollers will force a captured portion **8** of the leaflet into a gap **59** between the rollers, as can be seen in FIG. 5B.

The user may continue to actuate the drive assembly **70** to rotate one or both of the rollers **52** until the desired amount of tissue of the posterior leaflet **2** is advanced through the gap **59**, or until a predetermined maximum torque experienced by the rollers is reached. Once the desired amount of tissue is secured by the clip **50**, most or all of the portion of the posterior leaflet **2** that is billowed, loose, or floppy may be gathered and tightened. The clip **50** will remain clamped around the captured portion **8** of the posterior leaflet **2**, thereby securing the tissue in the gathered configuration, because the interaction between the spring lock member **68** and the ratcheting cam **64** will prevent the first roller **52a** from rotating in a direction opposite the rotational direction **R3**.

After the clip **50** has been adequately secured to the tissue of the posterior leaflet **2**, the device **10** may be withdrawn from the patient. To withdraw the device **10**, the hook **24** may first be withdrawn from engagement with the posterior leaflet **2** by moving the grasping wire **22** proximally. This action causes the hook **24** to straighten as the grasping wire **22** retracts into the containment tube **20**.

Then, the clip **50** can be detached from the device **10** by detaching the release wire **44** from the clip, as shown in FIG. 6. To detach the release wire **44**, the user may pull proximally on the release wire until the release wire detaches from the clip **50**. While the release wire **44** is being detached, the clip **50** is restrained from movement along the longitudinal axis **L3** of the outer tube **16** because the exposed end portion **58** of the pin **56** of the first roller **52a** is secured

12

between the drive belt **72** and the support surface **34** of the contact plate **30**. In embodiments where the release wire **44** is a suture, the suture may have a weakened portion near the location where the suture is attached to the clip **50**, such that a small distal portion of the suture remains attached to the clip, but the rest of the suture becomes detached from the small distal portion when a sufficient proximal pulling force is reached.

Subsequently, the user can move the support shaft **71** proximally, removing the support shaft from contact with the end portion **58** of the pin **56** of the first roller **52a**, thereby releasing the clip **50** from being retained by the drive belt **72** and the support surface **34** of the contact plate **30** and completing deployment of the clip from the outer tube **16**. Finally, the catheter assembly **12** may be withdrawn from the patient through the apex of the heart. After withdrawal of the device **10** from the patient, the clip **50** will remain clamped around the captured portion **8** of the posterior leaflet **2**, as shown in FIGS. 7A and 7B. If desired, the procedure described above may be repeated to apply one or more additional clips **50** onto the same posterior leaflet **2**.

An alternative embodiment of a device **110** for transcatheter gathering of heart valve leaflet tissue is shown in FIGS. 8A, 8B, 9A, and 9B. Similar to the device **10** described above, the device **110** includes an elongated catheter assembly **112** adapted to be inserted through the apex of a human heart so that a distal portion **114** of the catheter assembly may reach the patient's mitral valve **1** for repair thereof. The catheter assembly **112** includes a containment tube **120** disposed within an outer tube **116** along a longitudinal axis **L5** of the outer tube. The outer tube **116** has an opening **118** that extends in a direction parallel to the longitudinal axis **L5** and that extends partially around the circumference of the outer tube.

The catheter assembly **112** further includes a capture tool in the form of a grasping wire **122** that is longitudinally slidable within the containment tube **120** between a retracted position substantially entirely within the lumen of the containment tube, and a deployed position in which a distal portion **123** of the grasping wire protrudes from the distal tip **121** of the containment tube (FIG. 8A). The grasping wire **122** may have a linear configuration when fully retracted within the containment tube **120** and the distal portion **123** thereof may assume the shape of a hook **124** when deployed from the containment tube. When the grasping wire **122** is fully deployed from the containment tube **120** as shown in FIG. 9A, a contact portion **125** of the hook **124** extends to a location adjacent the opening **118**. The contact portion **125** of the hook **124** may be marked with one or more radiopaque markers **126** so that the location of the contact portion can be more easily tracked by a user relative to the opening **118**.

The catheter assembly **112** further includes a tissue securing component in the form of a clip **150** that is adapted to secure tissue of a heart valve leaflet that is captured therein, as will be described below. The clip **150** in the nature of an elongated member may be made of a memory metal and may be biased to curl into a substantially round configuration, such that the ends **151a** and **151b** (FIG. 8B) may overlap.

As can be seen in FIGS. 8A and 8B, the clip **150** in its initial condition extends around the peripheral edge **117** of the opening **118**. The clip **150** may be assembled onto the outer tube **116** by extending around retention posts **152** that extend from an outer surface **111** of the outer tube in a direction substantially perpendicular to the outer surface. The clip **150** may include one or more radiopaque markers **156** thereon, so that the location of the radiopaque markers **126** on the contact portion **125** of the hook **124** can be more

## 13

easily tracked by a user relative to the radiopaque markers on the clip. Furthermore, the radiopaque markers **156** on the clip **150** may allow a user to more easily track the location and/or orientation of the clip after it is deployed into tissue of the posterior leaflet **2**.

The retention posts **152** may be retractable into the outer tube when actuated by a user operating a handle (not shown) that is adapted to retract the retention posts. The retention posts **152** can be retracted by pull wires (not shown) that are connected at their distal ends to bases of the respective retention posts, and that extend through one or more lumens along the catheter assembly **112** to a handle, where the pull wires can be grasped at their proximal ends and pulled in a proximal direction by a user, or actuated in a proximal direction by a mechanism of the handle that is controllable by a user.

As shown in FIG. **8A**, the retention posts **152** are fully extended so that the clip **150** is retained in its initial condition extending around the peripheral edge **117** of the opening **118**. When the retention posts **152** are retracted into the outer tube **116**, the clip **150** is no longer retained around the peripheral edge **117**, so the clip may contract according to its bias, thereby tightening into a smaller diameter (e.g., as shown in FIG. **11** clamped around a captured portion **8** of the posterior leaflet **2** when deployed.

Alternatively, the clip **150** may have a plurality of spaced-apart eyelets extending therethrough (not shown), and the clip may be assembled onto the outer tube **116** by being fastened to corresponding eyelets (not shown) in the retention posts **152**. In this variation, rather than extending around outward-facing surfaces of the retention posts **152** (FIG. **8A**), the clip **150** can extend along inward-facing surfaces of the retention posts. A single pull wire can extend through all of the eyelets in the clip **150** and in the retention posts **152**, and both ends of the single pull wire can extend through a lumen extending along the catheter assembly **112** to a handle. To release the clip **150**, one end of the single pull wire can be grasped and pulled in a proximal direction by a user, until the single pull wire is withdrawn from all of the eyelets in the clip **150** and in the retention posts **152**, thereby releasing the clip so that it may contract according to its bias, thereby tightening into a smaller diameter.

The catheter assembly **12** further includes a roller **130** extending within the outer tube **116** substantially parallel to the longitudinal axis **L5** of the outer tube. The roller **130** may have a lumen **132** (FIG. **9B**) extending therethrough parallel to the longitudinal axis **L5**, and the containment tube **120** and the grasping wire **122** may extend through the lumen, or the lumen may serve as the containment tube for the grasping wire. Similar to the rollers **52** described above, the roller **130** may have a smooth outer surface **134**, a roughened or knurled surface, or a surface with protruding features (e.g., small spikes) that are configured to increase friction or gripping strength between the roller and tissue of a heart valve leaflet that may be inserted into the outer tube **116** adjacent the roller.

The roller **130** may be coupled to a drive assembly (not shown) that is operable to rotate the roller about its longitudinal axis, such drive assembly being available to be actuated by a user by control of an actuation handle (not shown). In one example, such a drive assembly may include belts and rollers that similar to the drive assembly **70** described above that can rotate the roller **130** in response to a user moving a button or wheel of an actuation handle. It is preferred that such a drive assembly include or be coupled

## 14

to a torque limiter that is adapted to prevent a user from exceeding a predetermined torque that may damage tissue of the leaflet **2**.

A pocket **113** (FIG. **10B**) may be defined inside the outer tube **116** between an inner surface **119** of the outer tube and the outer surface **134** of the roller. The roller **130** may be centered within the outer tube **116**, such that the lumen **132** of the roller extends along the longitudinal axis **L5** of the outer tube, as shown in FIG. **9B**, for example, so that there may be a pocket **113** on both sides of the roller. In other embodiments, the roller **130** may be offset relative to the longitudinal axis **L5** of the outer tube **116**, such that there may be a single pocket **113** on a first side of the roller, and such that a second side of the roller opposite the first side is disposed adjacent the inner surface **119** of the outer tube with a minimal clearance.

To use the device **110** for transcatheter gathering of heart valve leaflet tissue, the clip **150** may be initially disposed in its initial position shown in FIG. **8A** extending about the opening **118** and around the retention posts **152**, the retention posts being disposed in their extended positions.

Next, the distal portion **114** of the catheter assembly **112** may be inserted into a patient through the apex of the heart, for example, into the left ventricle, so that the distal portion extends between the posterior leaflet **2** and the anterior leaflet **3** of the mitral valve **1**. The opening **118** of the outer tube **116** may be disposed near the coaption line **5** of the mitral valve **1**, with the opening of the outer tube facing the posterior leaflet **2**. The distal end **121** (FIG. **8A**) of the containment tube **120** (FIG. **9B**) may be disposed above the coaption line **5**, such that the hook **124** may contact the upper surface **9b** of the posterior leaflet **2** when the hook is moved to its extended position.

Then, referring to FIG. **9A**, the hook **124** may then be deployed to an extended position by moving the distal portion **123** of the grasping wire **122** distally out of the containment tube **120**. No longer being constrained by the containment tube **120**, the distal portion **123** of the grasping wire **122** may assume the curved shape of the hook **124**. It is preferable that the hook **124** have a curvature when deployed that is sufficient to push a portion of the posterior leaflet **2** into the opening **118**, as shown in FIG. **9A**.

Once the hook **124** is extended full so that the contact portion **125** thereof has pushed a portion of the posterior leaflet **2** into the opening **118** of the outer tube **116**, the user may actuate a drive assembly (not shown) rotate the roller **130** in the rotational direction **R5** (FIG. **10B**). The rotation of the roller **130** as the posterior leaflet **2** is pushed against it will force a captured portion **8** of the leaflet into the opening **118** and into the pocket **113** between the roller and the inner surface **119** of the outer tube **116**, as can be seen in FIG. **10B**.

The user may continue to actuate the drive assembly to rotate the roller **130** until the desired amount of tissue of the posterior leaflet **2** is advanced into the pocket **113**, or until a predetermined maximum torque experienced by the rollers is reached. Once the desired amount of tissue is disposed in the pocket **113**, the clip **150** may be deployed onto the captured portion **8** of the posterior leaflet **2** by retracting the retention posts **152** into the outer tube **116**. Once the retention posts **152** are removed from contact with the clip **150**, the clip will contract around the captured portion **8** of the posterior leaflet **2** as can be seen in FIGS. **10A** and **11**. Once the captured portion **8** has been secured by the clip **150**, most or all of the portion of the posterior leaflet **2** that is billowed, loose, or floppy may be gathered and tightened.

15

After the clip **50** has been adequately secured in the tissue of the posterior leaflet **2**, the device **110** may be withdrawn from the patient. To withdraw the device **110**, the hook **124** may first be withdrawn from engagement with the posterior leaflet **2** by moving the grasping wire **122** proximally. This action causes the hook **124** to straighten as the grasping wire **122** retracts into the containment tube **120**.

Then, the captured portion **8** of the posterior leaflet **2** may be removed from the pocket **113** of the outer tube **116** by rotating the roller **130** in a direction opposite the direction **R5** that was used to gather the leaflet tissue in the pocket. Rotating the roller **130** in this opposite direction will push the captured portion **8** out of the pocket **113** and out of the opening **118** of the outer tube **116**.

After the captured portion **8** of the posterior leaflet **2** is removed from the outer tube **116**, the catheter assembly **112** may be withdrawn from the patient through the apex of the heart. After withdrawal of the device **110** from the patient, the clip **150** will remain clamped around the captured portion **8** of the posterior leaflet **2**, as shown in FIG. **11**. If desired, the procedure described above may be repeated to apply one or more additional clips **150** onto the same posterior leaflet **2**.

In another alternate embodiment, as shown in FIG. **12**, a device **110a** may include two rollers **130a** and **130b** extending within the elongated tube **116a**, each roller having a rotational axis substantially parallel to the longitudinal direction of the outer tube **116a**, such that a pocket **113a** is defined between adjacent outer surfaces **134** of the rollers. In such an embodiment, when leaflet tissue is drawn into the opening **118**, the first roller **130a** may be rotated in a first rotational direction **R6**, and friction between captured tissue and the first and second rollers will cause the second roller **130b** to rotate in a second rotational direction **R7** opposite the first rotational direction. Alternatively, both of the rollers **130a**, **130b** may be rotated by a user in respective opposite directions **R6**, **R7**. The device **110a** may include a capture tool in the form of a grasping wire **122a** that is longitudinally slidable within a containment tube **120a**, similar to the grasping wire **122** and the containment tube **120** described above, except that the containment tube **120a** may be located adjacent an inner surface **119** of the outer tube **116a** at a periphery of the pocket **113a**.

Yet another alternative embodiment of a device **110b** for transcatheter gathering of heart valve leaflet tissue is shown in FIGS. **13A** and **13B**. The device **110b** is similar to the device **110** described above, but the device **110b** includes an alternate outer tube arrangement. As shown in FIGS. **13A** and **13B**, the device **110b** has two openings **118a** and **118b** at opposite sides of the outer tube **116b**.

In use for gathering and securing of leaflet tissue, the device **110b** functions similarly as the device **110** described above, except that rather than gathering tissue in a pocket inside the outer tube, the roller **130** of the device **110b** rotates in a direction **R8** to guide the captured portion **8** of the posterior leaflet **2** into the outer tube **116b** via the first opening **118a** and out of the outer tube via the second opening **118b**. Once the desired amount of leaflet tissue has been passed through the outer tube **116b**, the retention posts **152** can be retracted into the outer tube, and the clip **150** can be released to clamp around the captured portion **8** of the posterior leaflet **2**. Finally, the roller **130** can be rotated in a direction that is the reverse of the direction **R8** to withdraw the captured portion **8** from the outer tube **116b**. After the clamped tissue has been withdrawn from the device **110b**, the device may be withdrawn from the patient.

16

Still another alternative embodiment of a device **110c** for transcatheter gathering of heart valve leaflet tissue is shown in FIGS. **14A** and **14B**. The device **110c** is similar to the device **110b** described above, but the device **110c** includes an alternate outer roller arrangement. As shown in FIGS. **14A** and **14B**, the device **110c** has a roller **130c** having an oblong cross-section. Such a roller **130c** may provide a better gripping force between the surface **134c** of the roller and a captured portion **8** of the posterior leaflet **2**. In use for gathering and securing of leaflet tissue, the device **110c** functions similarly as the device **110b** described above.

Another alternative embodiment of a device **110d** for transcatheter gathering of heart valve leaflet tissue is shown in FIG. **15**. The device **110d** is similar to the device **110b** described above, but the device **110d** includes an alternate clip arrangement. As shown in FIG. **15**, the device **110d** has a first clip **150a** extending around the first opening **118a** of the outer tube **116d** and a second clip **150b** extending around the second opening **118b** of the outer tube.

The first clip **150a** and the second clip **150b** may have a different pattern of radiopaque markers so that the orientation of the outer tube **116d** can be more easily determined by the user. For example, the first clip **150a** can have one radiopaque marker **156a** thereon, and the second clip **150b** can have two radiopaque markers **156b** thereon. Such a device **110c** having two clips **150a**, **150b** can permit a user more flexibility after insertion of the device into a patient. For example, either of the clips **150a** or **150b** may be used to capture tissue of the posterior leaflet **2**, depending on which clip is facing the posterior leaflet. In use for gathering and securing of leaflet tissue, the device **110d** functions similarly as the device **110b** described above.

In the devices shown in the figures, particular structures are shown that are adapted to gather, secure, and repair heart valve leaflet tissue. The invention also contemplates the use of any alternative structures for such purposes, including structures having different lengths, shapes, and configurations. For example, although the capture tool is shown in the form of a grasping wire **22** or **122**, the capture tool may take other forms, including for example, a pincer-like structure such as a clamp. Furthermore, although the grasping wires **22** and **122** are shown as having a hook **24** and **124**, respectively, the distal portion of the grasping wire may have any shape or configuration that may be adapted to grasp a target portion of valve leaflet tissue and help to capture such tissue inside or adjacent the outer tube such that a clip may be applied to the captured tissue.

Although the devices described herein are shown as being adapted to apply a single clip **50** or **150** onto a posterior leaflet **2**, the invention contemplates devices that are adapted to apply a plurality of clips to the leaflet tissue during a single insertion of the device into a patient. For example, the retention posts **152** may be long enough to accommodate a plurality of clips **150** thereon. In such an embodiment, while leaflet tissue is captured within the outer tube **116**, the retention posts **152** may be retracted to a first position to apply a first clip **150** to the tissue at a first target location, and the retention posts may then be further retracted to a second position to apply a second clip **150** to the tissue at a second target location spaced from the first location.

Although the various gathering devices have been described herein in connection with tightening the posterior leaflet of a mitral valve, all of these devices may be used on other heart valve leaflets, such as the anterior leaflet of the mitral valve, or on any other tissue of the body for which a reduction in the length of the tissue would be beneficial.

17

Although the invention herein has been described with reference to particular embodiments in which the catheter assembly is inserted into the patient through the apex of the heart (i.e., transapical insertion), it is to be understood that the invention contemplates embodiments in which the catheter assembly extends through a portion of the vasculature of the patient to reach the heart, for example, through a transfemoral or subclavian artery, or using a transseptal procedure. Any other percutaneous technique for accessing the interior of the heart may also be used. In such embodiments, some of the device components may have to be oriented in a different direction to that described herein. For example, the invention contemplates embodiments in which the distal portion of the catheter assembly approaches the mitral valve from the upstream side as well as from the downstream side of the valve.

Although the invention herein has been described with reference to particular embodiments, it is to be understood that these embodiments are merely illustrative of the principles and applications of the present invention. It is therefore to be understood that numerous modifications may be made to the illustrative embodiments and that other arrangements may be devised without departing from the spirit and scope of the present invention as defined by the appended claims.

It will be appreciated that the various dependent claims and the features set forth therein can be combined in different ways than presented in the initial claims. It will also be appreciated that the features described in connection with individual embodiments may be shared with others of the described embodiments.

The invention claimed is:

**1.** A device for transcatheter gathering of tissue of a heart valve leaflet, comprising:

an elongated tube extending in a longitudinal direction and having an open distal end, the elongated tube having an inner surface and a lumen extending there-through; and

a tissue securing component disposed at the distal end of the elongated tube, the tissue securing component comprising a clip including a roller and a support element, the roller being rotatable relative to the support element,

wherein the tissue securing component is adapted to be applied to the captured tissue to hold the captured tissue in a gathered configuration, and

wherein the roller is configured to rotate about a rotational axis of the roller only in a first rotational direction and not in a second rotational direction opposite the first rotational direction.

**2.** The device of claim **1**, wherein the tissue securing component is releasable from the elongated tube so as to remain on the tissue as the elongated tube is removed from the tissue.

**3.** The device of claim **1**, wherein the roller is a first roller and the support element is a second roller, the second roller being rotatable relative to the first roller.

**4.** The device of claim **1**, wherein the roller is a first roller and the support element is a second roller, the second roller being fixed relative to a rotational axis of the first roller.

**5.** The device of claim **1**, wherein the support element is fixed relative to a rotational axis of the roller.

**6.** The device of claim **1**, wherein the tissue securing component includes two coupling plates extending between the roller and the support element.

18

**7.** The device of claim **1**, wherein the roller has an outer surface that is roughened, knurled, or having features that protrude from the outer surface.

**8.** The device of claim **1**, further comprising a drive assembly adapted to rotate the roller relative to the support element.

**9.** The device of claim **8**, wherein the drive assembly is movable in the elongated tube in the longitudinal direction, the drive assembly being movable between a proximal position in which a distal end of the drive assembly is spaced apart from the roller and a distal position in which the distal end of the drive assembly contacts a portion of the roller.

**10.** The device of claim **9**, wherein the drive assembly includes a belt extending around two rollers.

**11.** The device of claim **1**, further comprising an actuation shaft movable in the elongated tube in the longitudinal direction, the actuation shaft adapted to move the tissue securing component therewith relative to the elongated tube.

**12.** The device of claim **11**, further comprising a contact plate having a guide surface disposed at an oblique angle relative to the longitudinal direction, the guide surface being adapted to guide motion of the tissue securing component such that the roller pivots relative to the actuation shaft about an axis perpendicular to a rotational axis of the roller when the actuation shaft is moved distally.

**13.** The device of claim **12**, further comprising a capture tool movable in the elongated tube between a retracted position and an extended position, the capture tool being operable to capture the tissue of the heart valve leaflet and to draw the captured tissue into the tissue securing component.

**14.** The device of claim **11**, further comprising a release wire removably coupled to the tissue securing component and extending through the elongated tube to a proximal end of the device.

**15.** The device of claim **2**, further comprising a capture tool movable in the elongated tube between a retracted position and an extended position, the capture tool being operable to capture the tissue of the heart valve leaflet and to draw the captured tissue into the tissue securing component.

**16.** The device of claim **15**, wherein a distal end of the capture tool has a hook shape.

**17.** The device of claim **16**, wherein the capture tool includes a grasping wire slidably disposed in a containment tube, and a distal portion of the grasping wire is adapted to change from a linear shape to the hook shape when the distal portion of the grasping wire is extended out from the containment tube.

**18.** The device of claim **17**, wherein the grasping wire is partially or entirely made from a shape-memory material.

**19.** The device of claim **1**, further comprising a capture tool movable in the elongated tube between a retracted position and an extended position, the capture tool being operable to capture the tissue of the heart valve leaflet and to draw the captured tissue into the tissue securing component.

**20.** The device of claim **1**, wherein the tissue securing component includes a ratchet permitting rotation of the roller about the rotational axis of the roller only in the first rotational direction, the ratchet preventing rotation of the roller in the second rotational direction.

\* \* \* \* \*