



(12) **United States Patent**
Elder et al.

(10) **Patent No.:** **US 9,629,414 B2**
(45) **Date of Patent:** **Apr. 25, 2017**

(54) **SOLE STRUCTURE FOR AN ARTICLE OF FOOTWEAR**

(56) **References Cited**

U.S. PATENT DOCUMENTS

(71) Applicant: **NIKE, Inc.**, Beaverton, OR (US)
(72) Inventors: **Zachary M. Elder**, Portland, OR (US);
Lee D. Peyton, Tigard, OR (US)
(73) Assignee: **NIKE, Inc.**, Beaverton, OR (US)
(*) Notice: Subject to any disclaimer, the term of this patent is extended or adjusted under 35 U.S.C. 154(b) by 250 days.

5,185,943 A *	2/1993	Tong	A43B 13/184	36/27
5,187,883 A	2/1993	Penney			
5,396,718 A	3/1995	Schuler et al.			
5,572,804 A *	11/1996	Skaja et al.	36/29	
5,628,128 A *	5/1997	Miller	A43B 7/1495	36/114
6,082,023 A	7/2000	Dalton			
6,438,870 B2 *	8/2002	Nasako	A43B 13/181	36/103
6,823,612 B2	11/2004	Manz et al.			
6,983,557 B2	1/2006	Manz et al.			
7,020,988 B1	4/2006	Holden et al.			
7,082,699 B2	8/2006	Nishiwaki et al.			
7,162,815 B2 *	1/2007	Miyauchi	A43B 13/181	36/103
7,254,907 B2	8/2007	Nishiwaki et al.			
7,370,443 B2	5/2008	Gibert et al.			
7,434,337 B2	10/2008	Gibert et al.			

(21) Appl. No.: **13/939,522**
(22) Filed: **Jul. 11, 2013**

(65) **Prior Publication Data**
US 2015/0013185 A1 Jan. 15, 2015

(Continued)
Primary Examiner — Anna Kinsaul
Assistant Examiner — Jillian K Pierorazio
(74) *Attorney, Agent, or Firm* — Banner & Witcoff, Ltd.

(51) **Int. Cl.**
A43B 13/00 (2006.01)
A43B 13/14 (2006.01)
A43B 13/12 (2006.01)
A43B 13/18 (2006.01)
A43B 13/28 (2006.01)

(57) **ABSTRACT**
A sole structure of an article of footwear has a support assembly structure including a flexure element and an upper support element. The flexure element may have a central portion located between first and second ground-contacting or lower regions, wherein the central portion may have a downwardly concavely-curved shell-like region. The flexure element also may have first and second flanges extending upward from the first and second lower regions, respectively. The upper support element is positioned above the central portion and between the first and second flanges of the flexure element. When a vertical compressive load is first applied to the upper support element, the upper support element moves vertically relative to the first and second flanges. An article of footwear having the sole structure attached to an upper is also provided.

(52) **U.S. Cl.**
CPC **A43B 13/14** (2013.01); **A43B 13/122** (2013.01); **A43B 13/184** (2013.01); **A43B 13/28** (2013.01)

(58) **Field of Classification Search**
CPC A43B 13/141; A43B 13/143; A43B 7/144; A43B 3/246; A43B 13/127; A43B 13/28; A43B 13/184; A43B 13/122
USPC 36/28, 35 R, 83, 92, 103
See application file for complete search history.

36 Claims, 19 Drawing Sheets

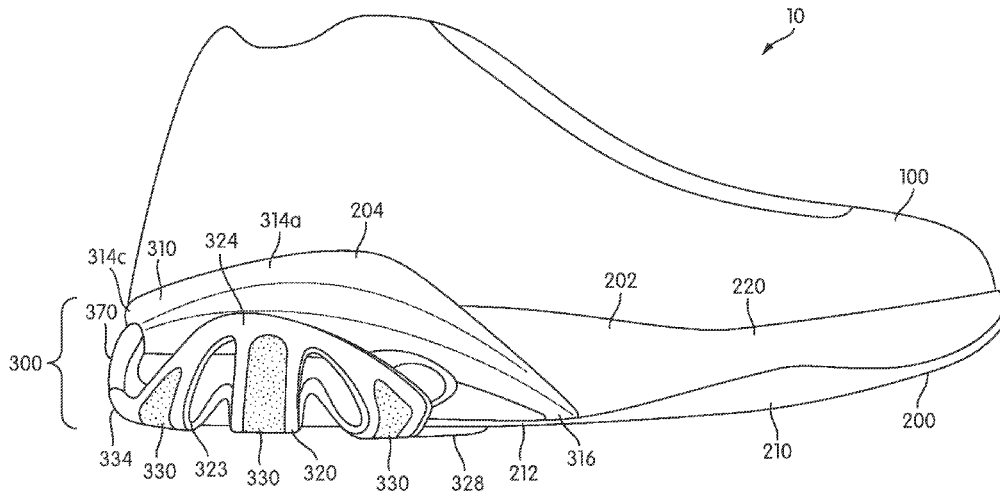

(56)

References Cited

U.S. PATENT DOCUMENTS

7,464,489	B2 *	12/2008	Ho	A43B 13/181	36/28	2006/0201028	A1 *	9/2006	Chan	A43B 7/142
7,866,063	B2 *	1/2011	Caine	A43B 13/026	36/114	2008/0155859	A1 *	7/2008	Chandler	A43B 13/14
7,946,059	B2 *	5/2011	Borel	A43B 13/026	36/28	2009/0019729	A1 *	1/2009	Nakano et al.	36/91
7,987,618	B2 *	8/2011	Nishiwaki	A43B 13/181	36/25 R	2009/0113758	A1 *	5/2009	Nishiwaki	A43B 13/10
8,453,344	B2 *	6/2013	Nishiwaki	A43B 13/10	36/103	2009/0139114	A1 *	6/2009	Malek	A43B 7/144
2003/0051373	A1 *	3/2003	Goodwin	A43B 13/12	36/29	2010/0071228	A1 *	3/2010	Crowley, II	A43B 13/181
2003/0140523	A1	7/2003	Issler				2010/0281711	A1 *	11/2010	Vestuti	A43B 1/0072
2003/0200678	A1	10/2003	Nishiwaki et al.				2011/0185590	A1 *	8/2011	Nishiwaki	A43B 5/06
2004/0177530	A1	9/2004	Nishiwaki et al.				2012/0131819	A1 *	5/2012	Loverin	A43B 1/10
2005/0246922	A1	11/2005	Gibert et al.									36/35 R

* cited by examiner

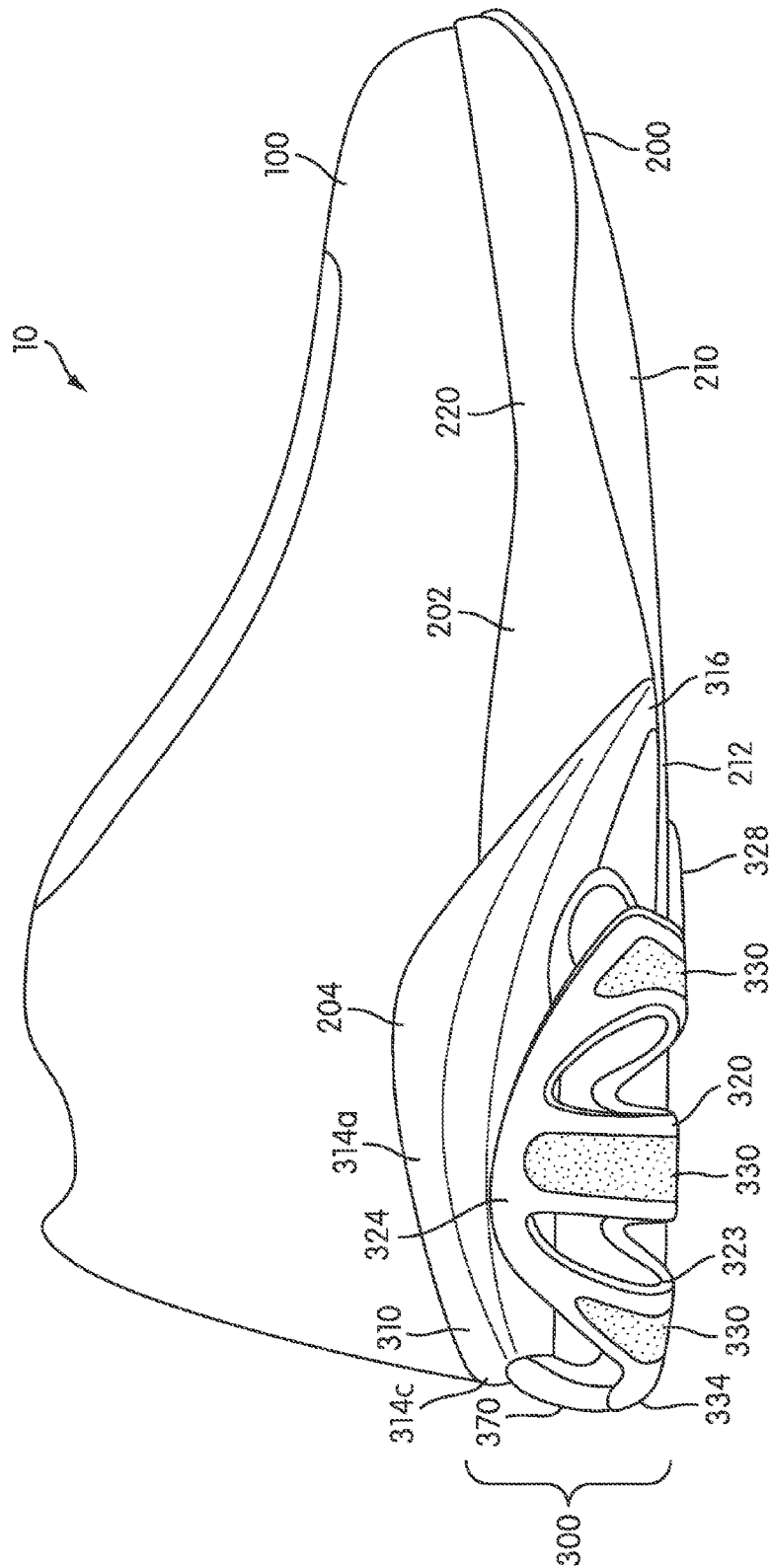

FIG. 1A

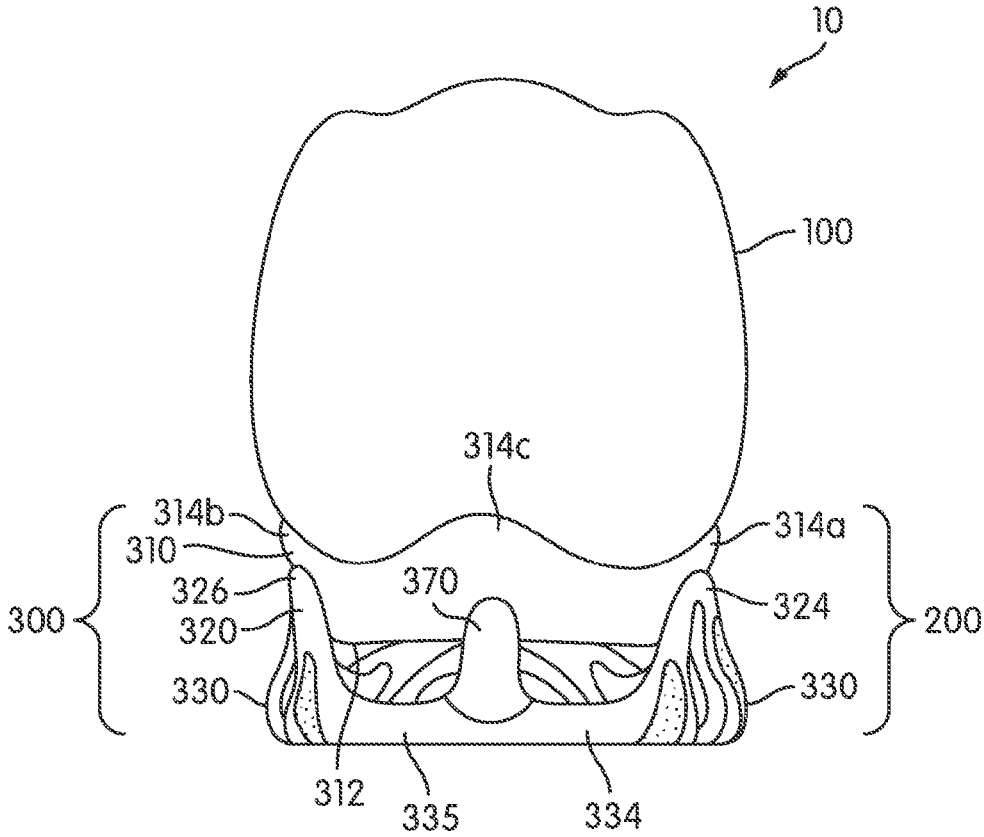

FIG. 1B

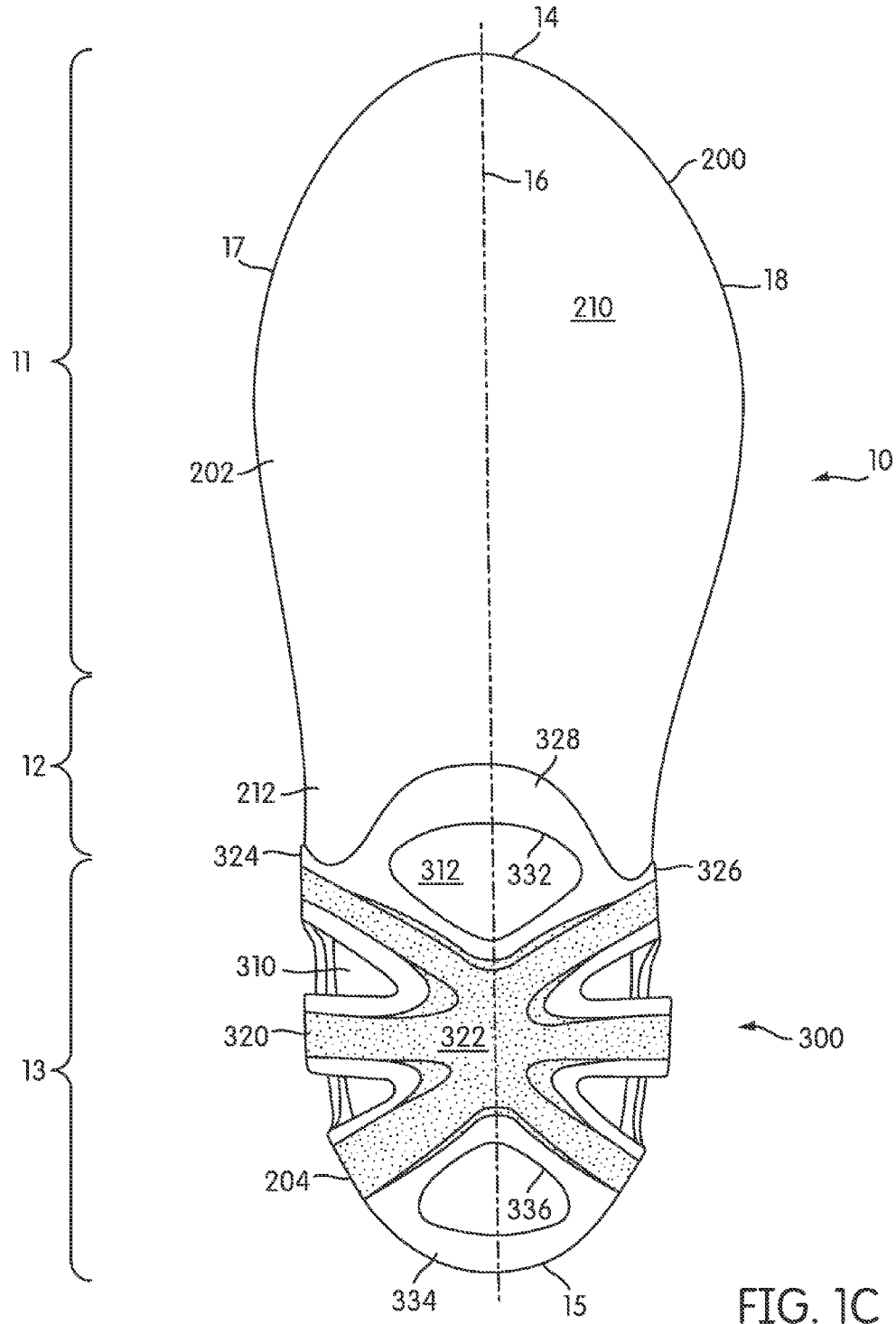

FIG. 1C

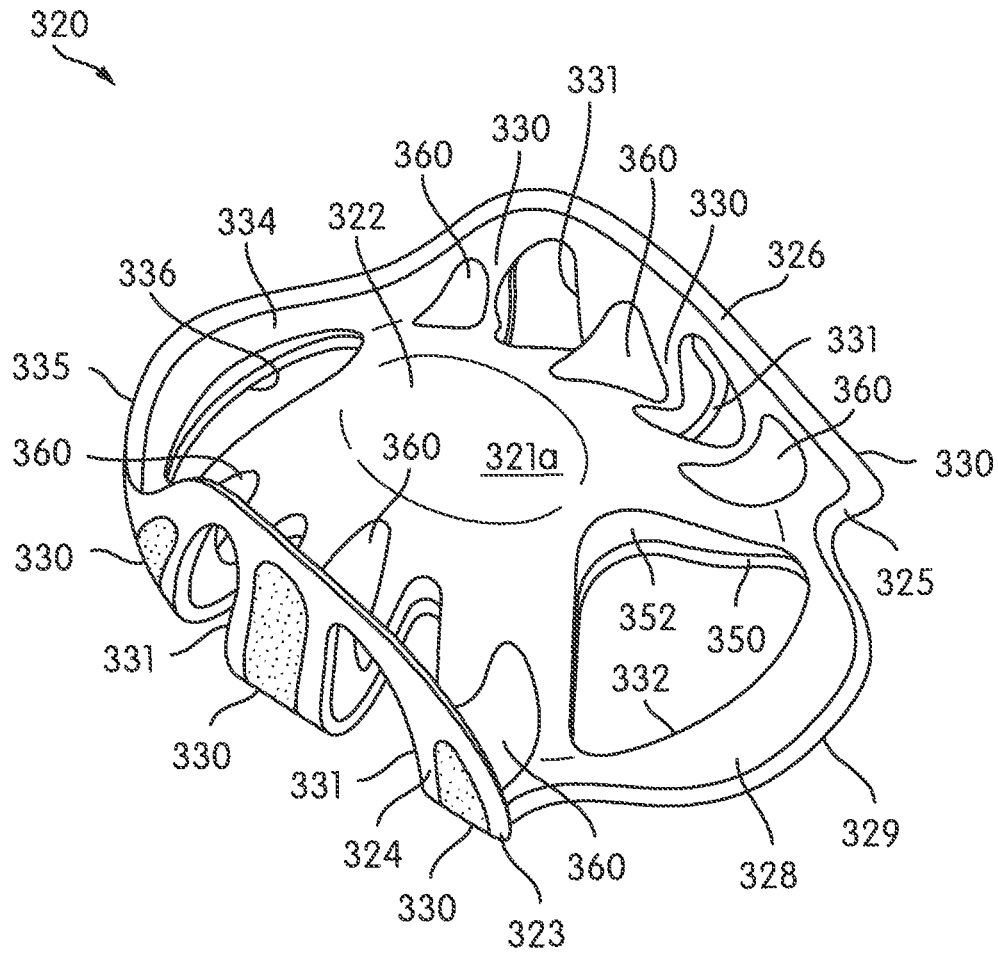

FIG. 2A

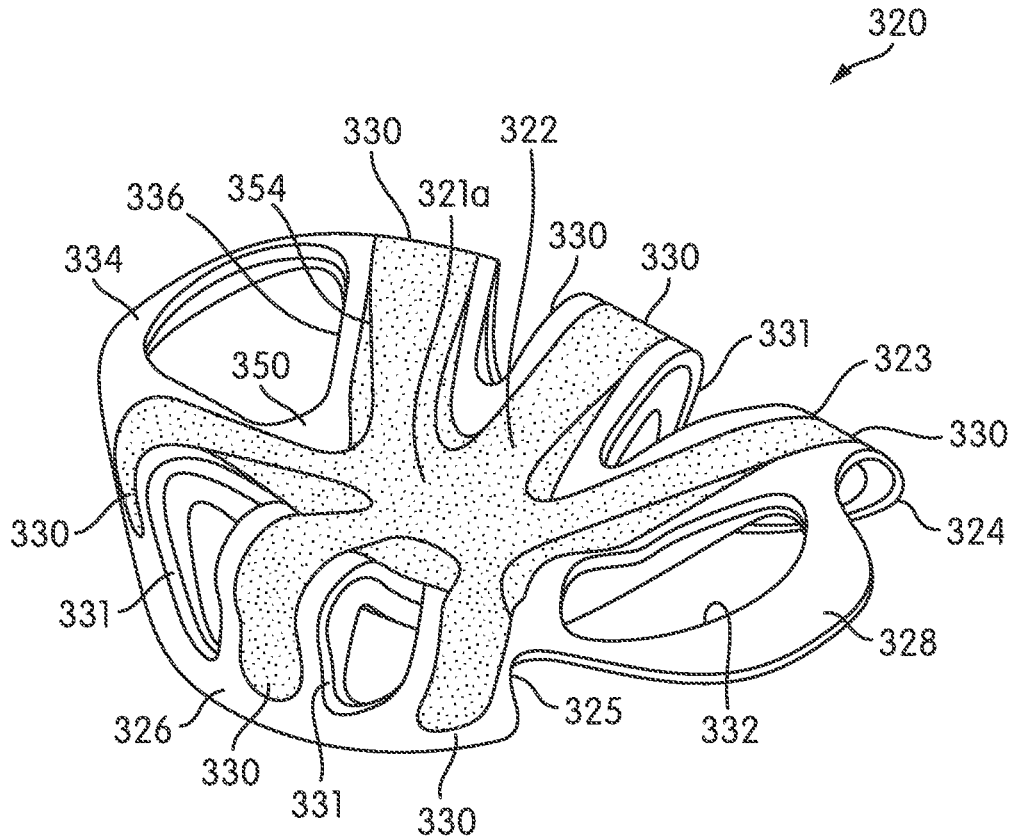

FIG. 2B

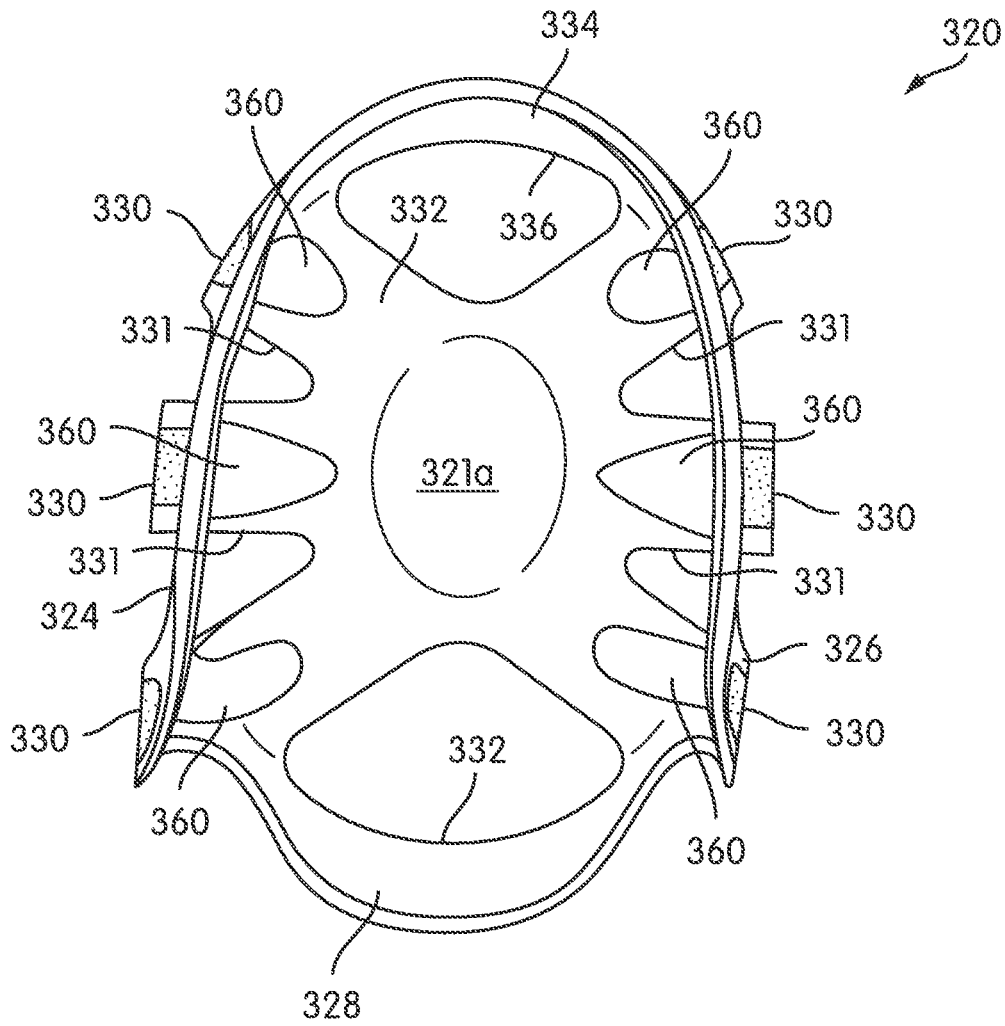

FIG. 2C

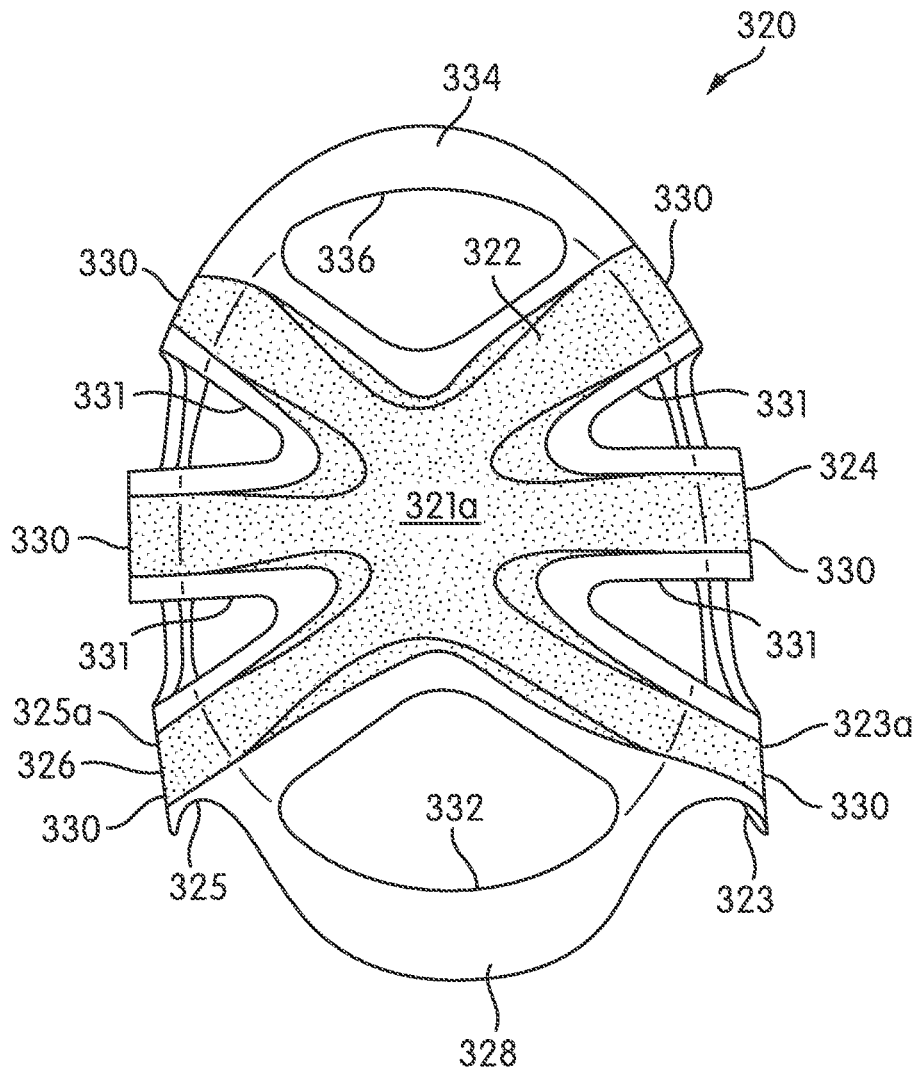

FIG. 2D

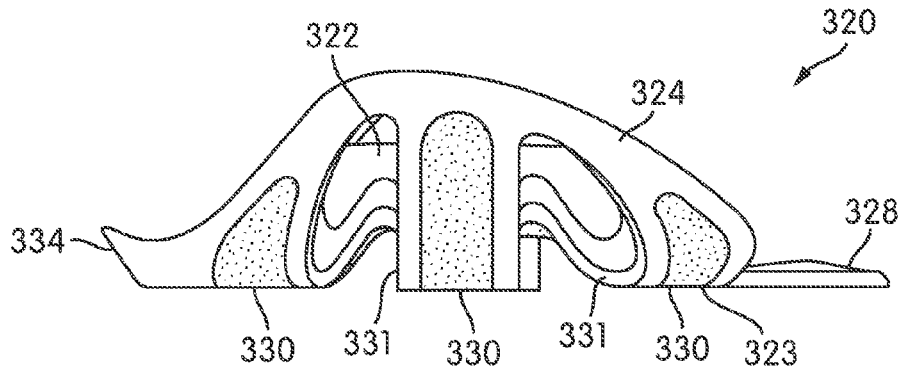

FIG. 2E

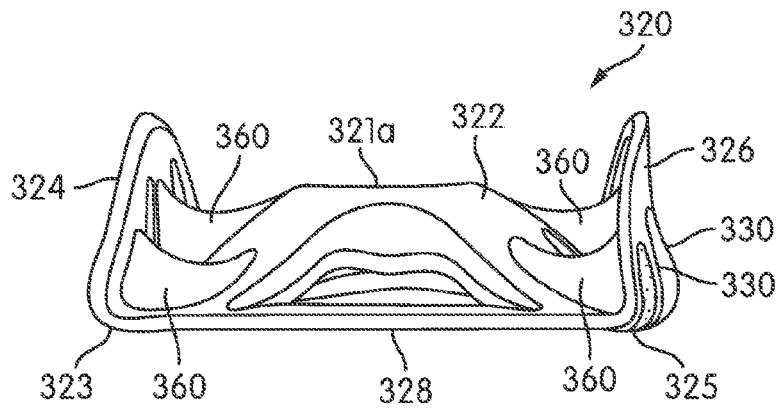

FIG. 2F

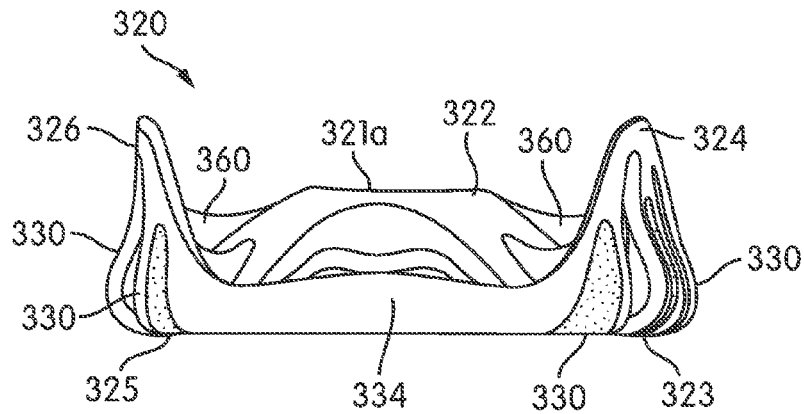

FIG. 2G

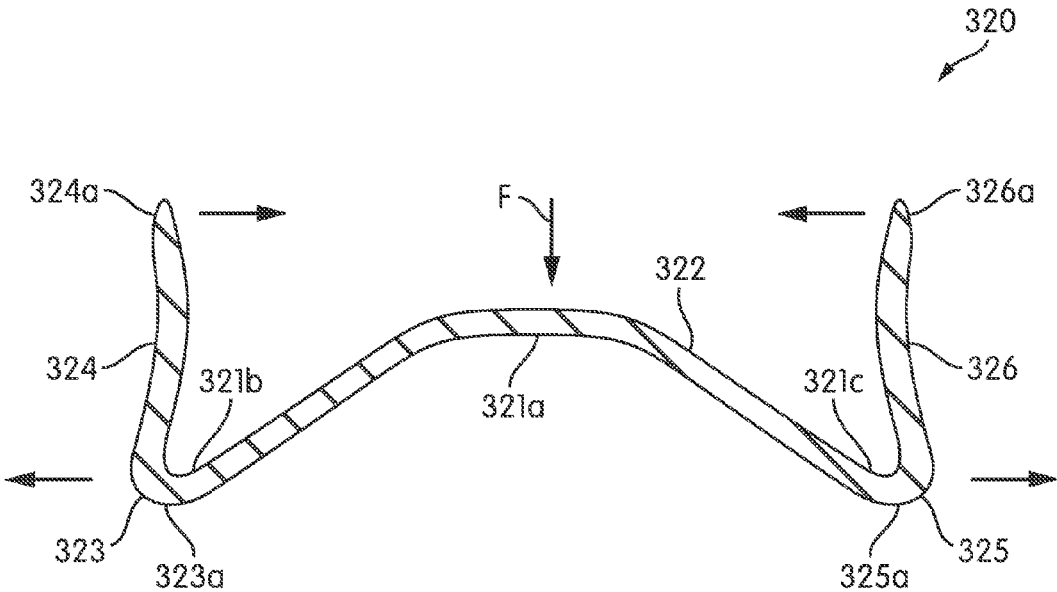

FIG. 3

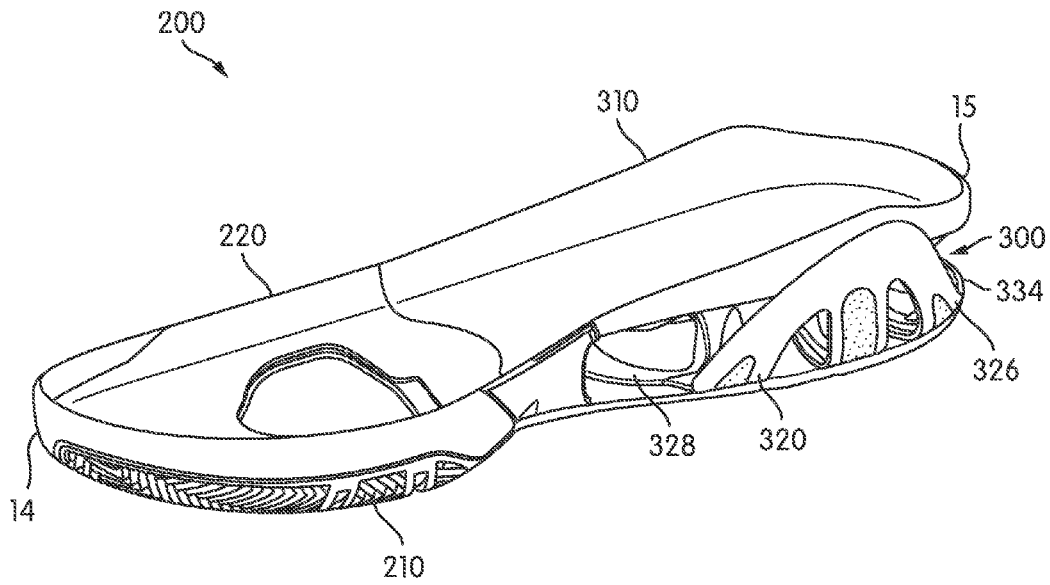

FIG. 4A

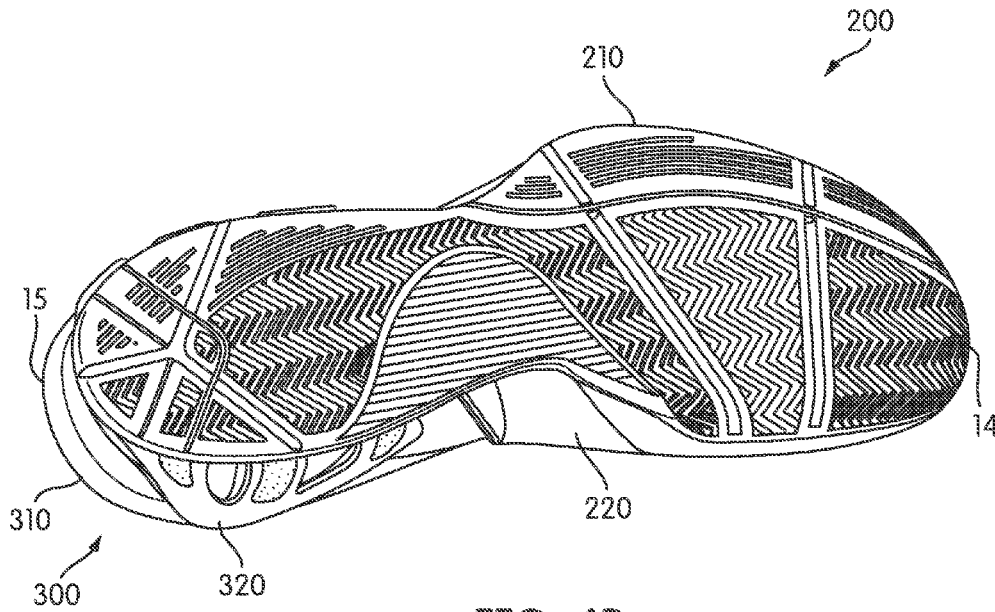

FIG. 4B

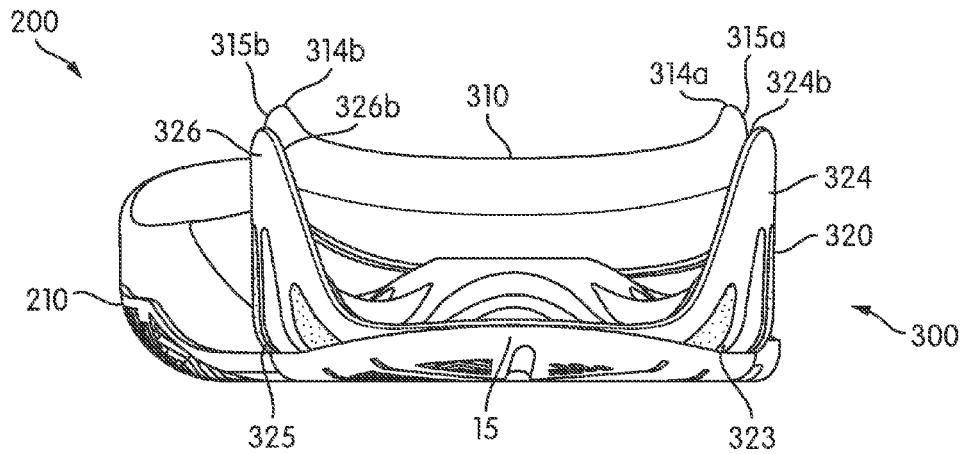

FIG. 4C

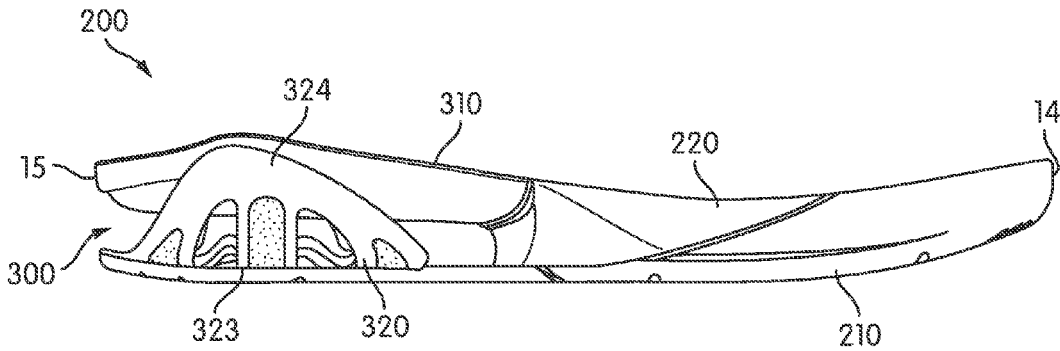

FIG. 4D

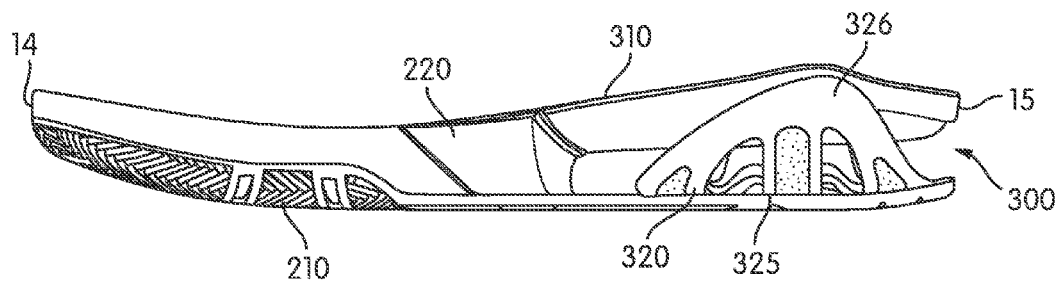

FIG. 4E

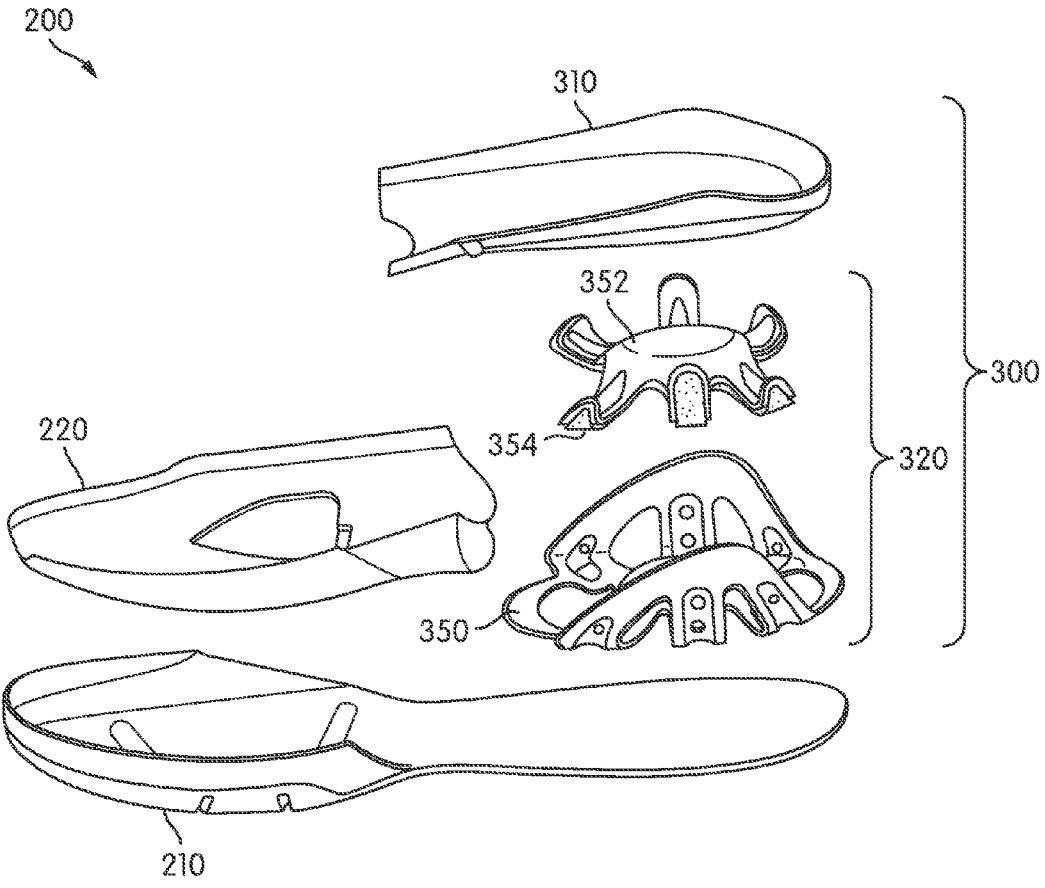

FIG. 4F

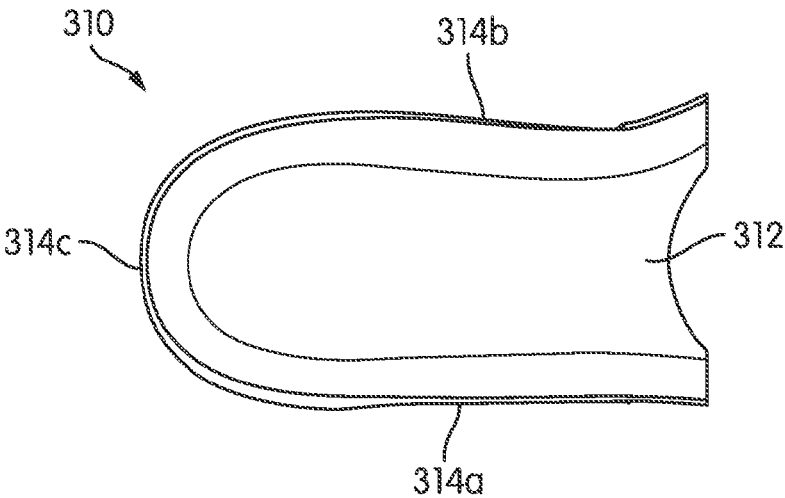

FIG. 5A

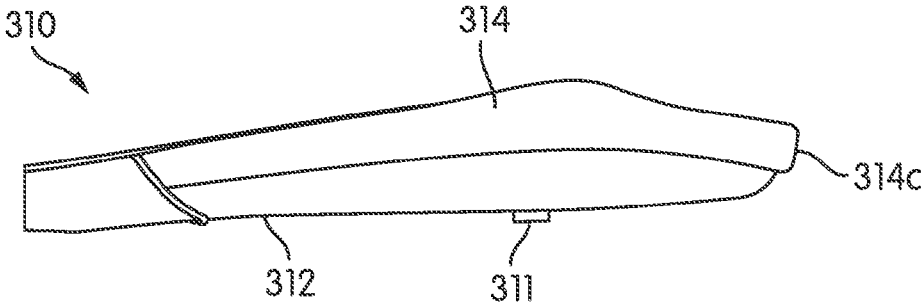

FIG. 5B

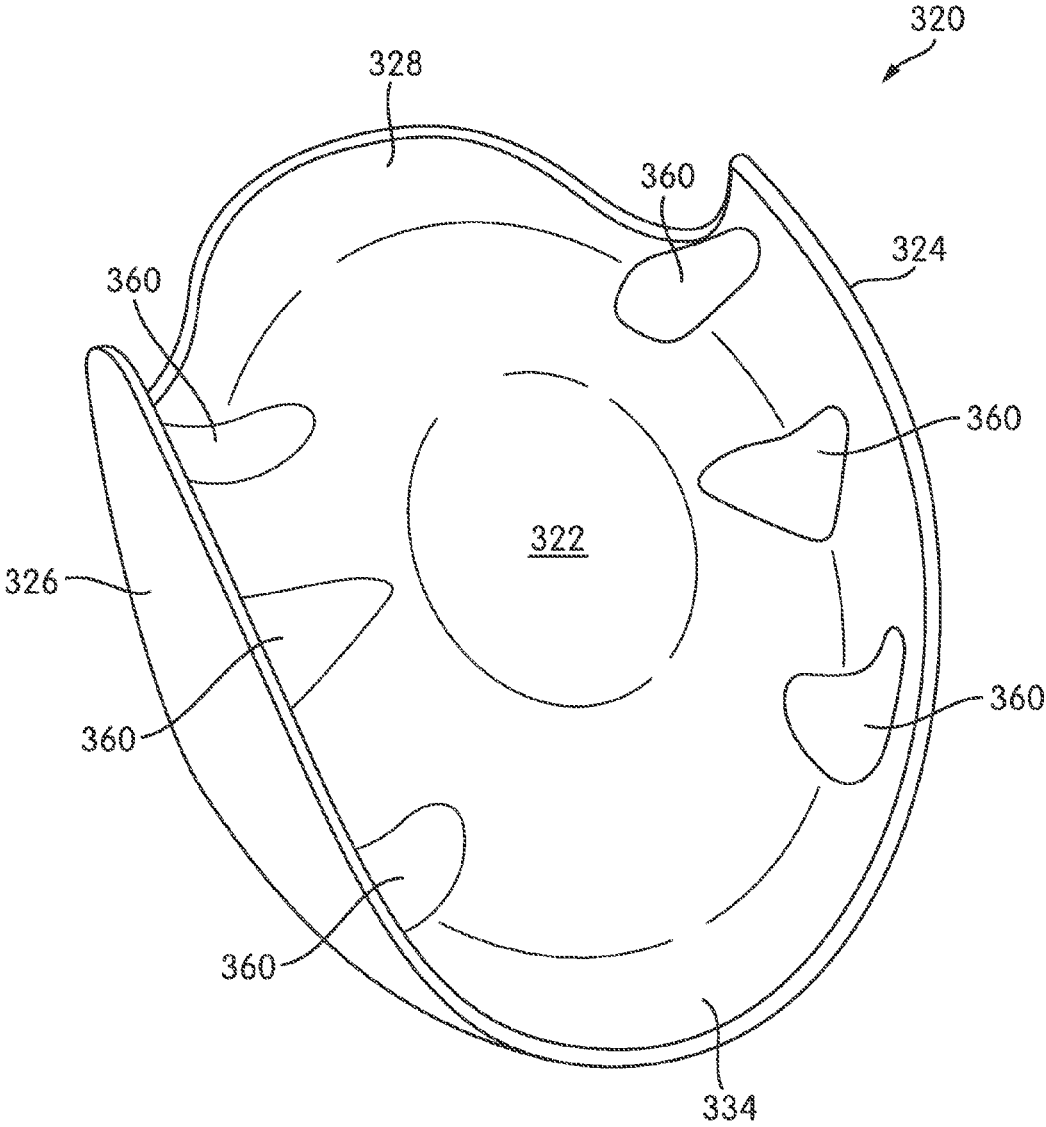

FIG. 6

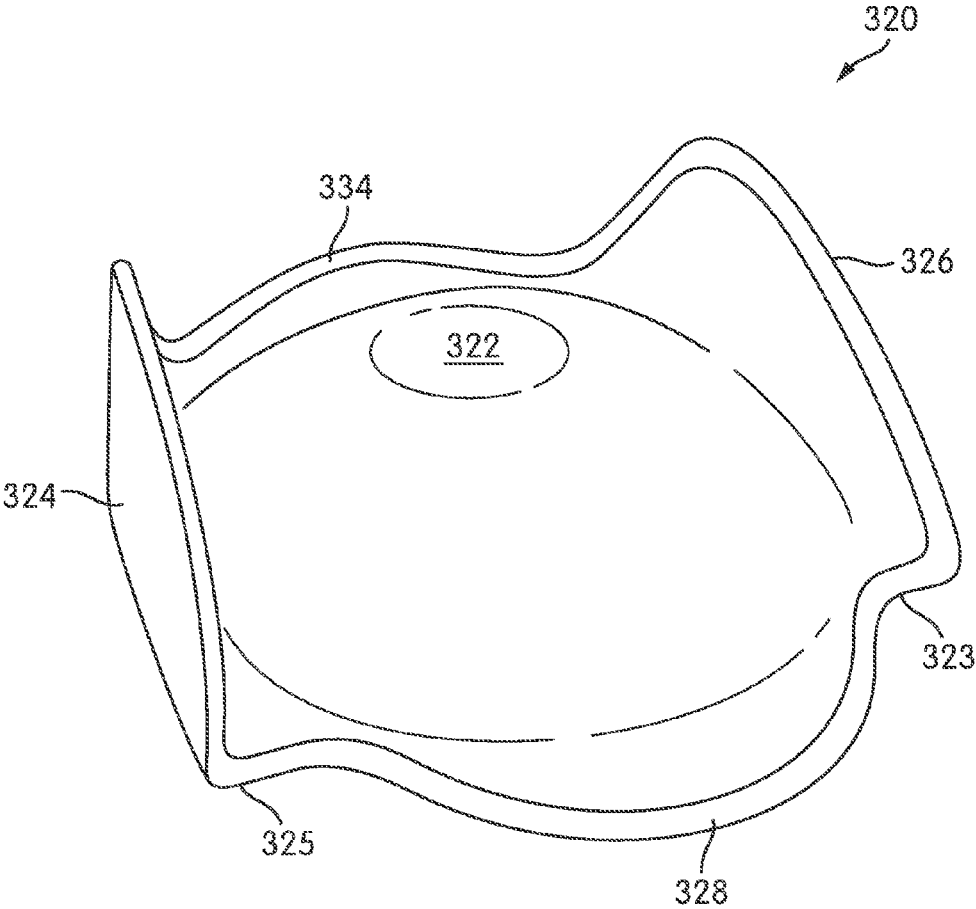

FIG. 7

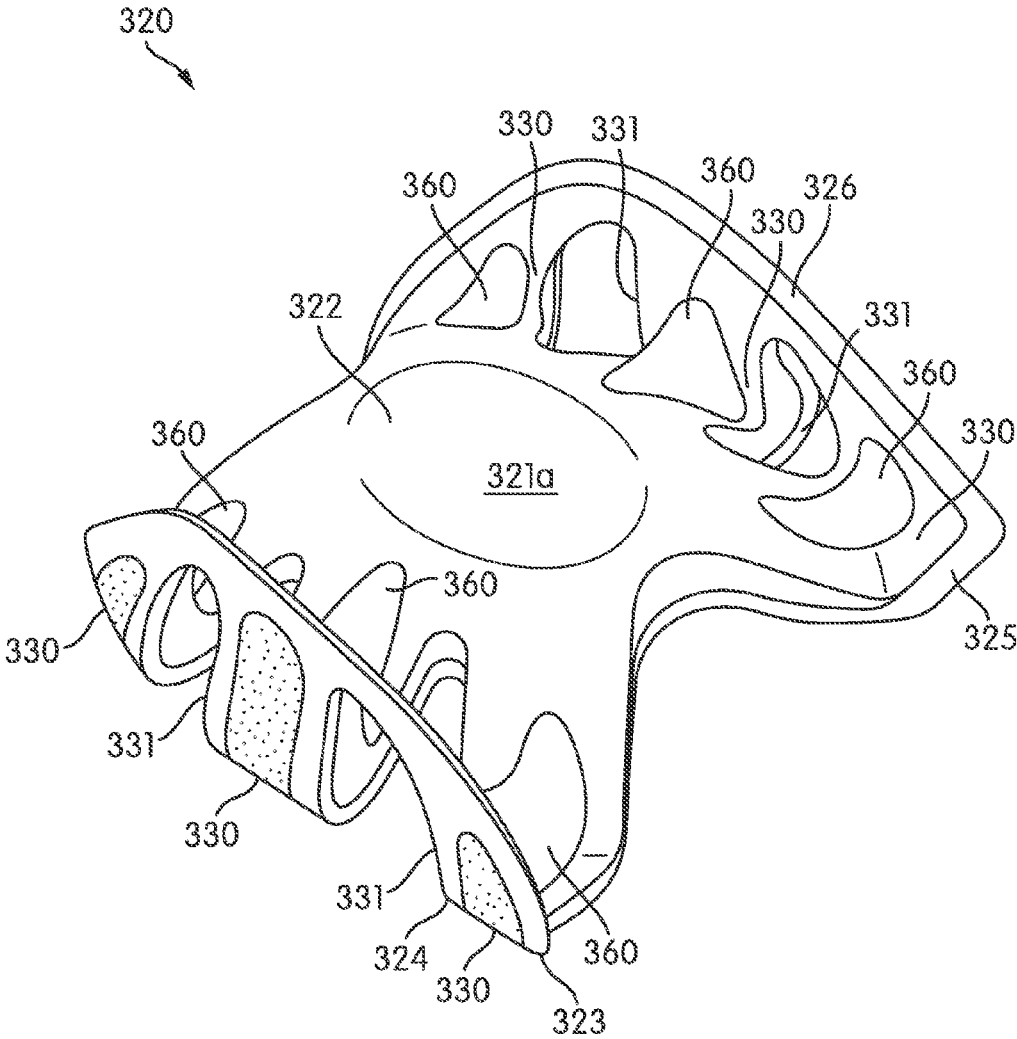

FIG. 8

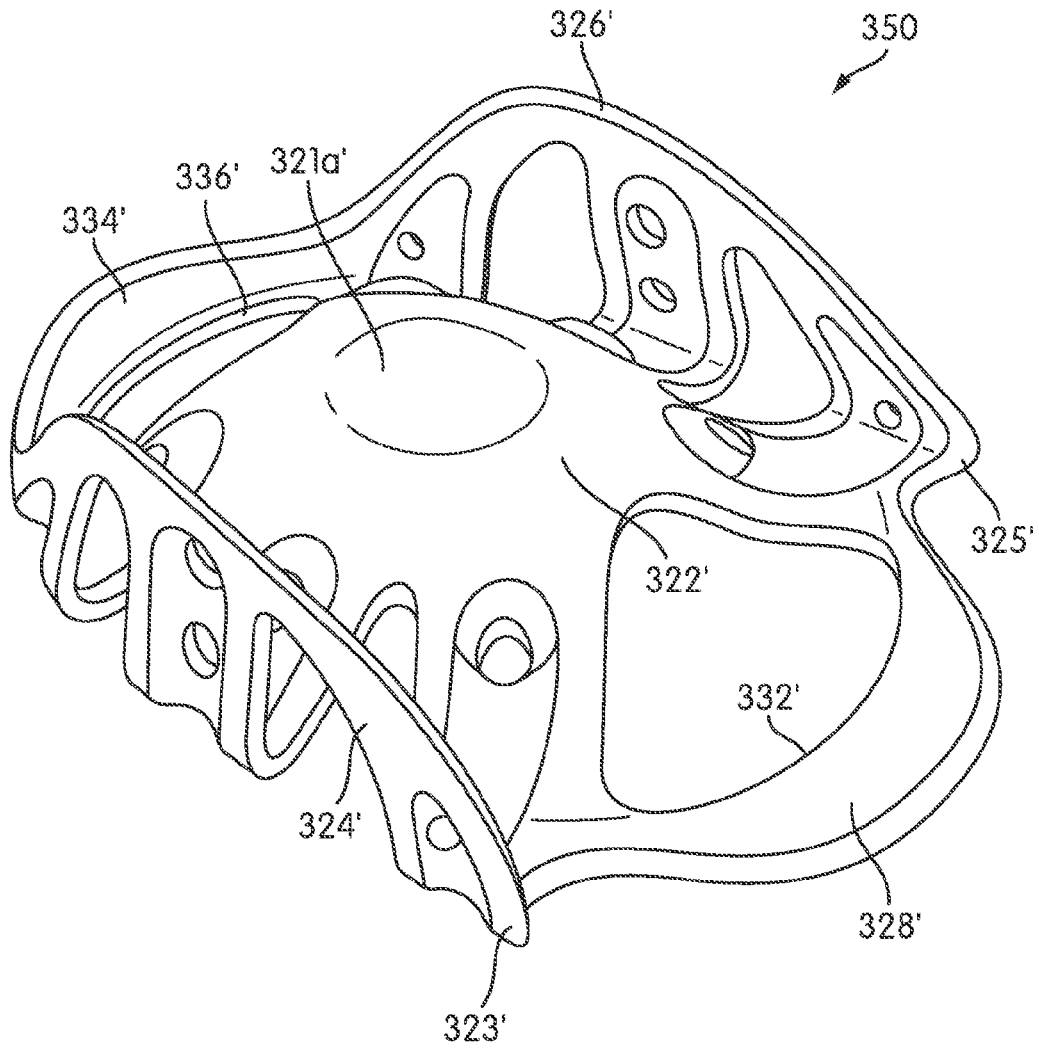

FIG. 9A

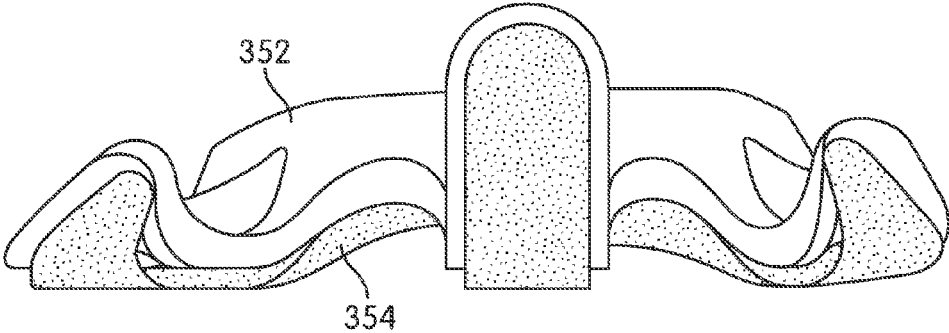

FIG. 9B

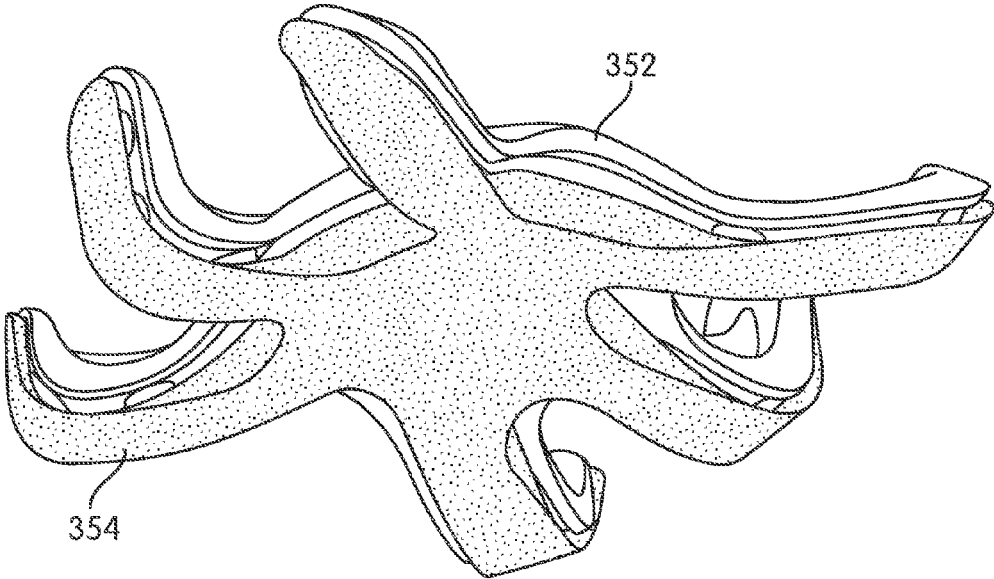

FIG. 9C

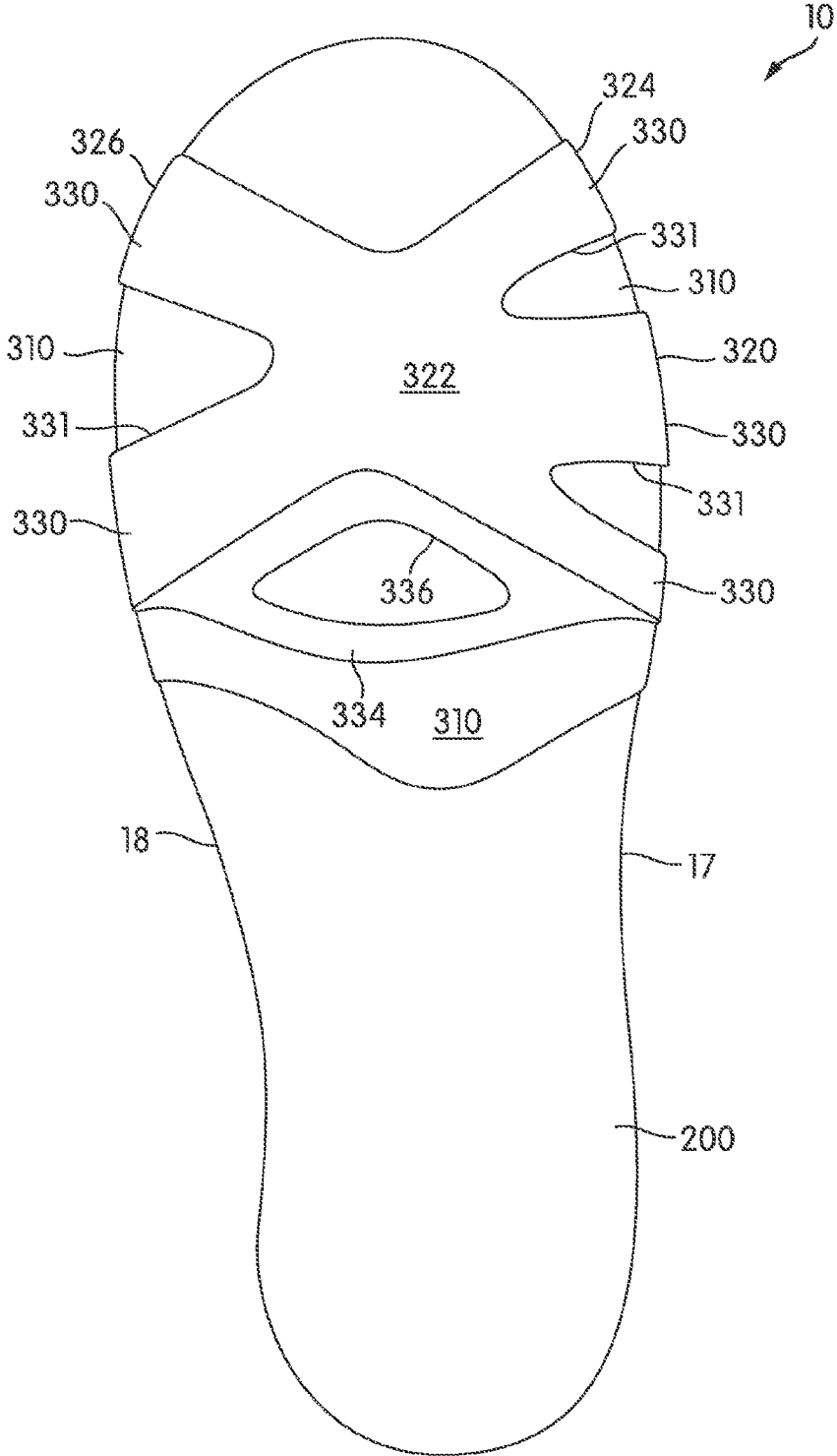

FIG. 10

1

SOLE STRUCTURE FOR AN ARTICLE OF FOOTWEAR

FIELD

Aspects of the present invention relate to sole structures for articles of footwear and articles of footwear including such sole structures. More particularly, various examples relate to sole structures having improved vertical compression and transverse stiffness characteristics.

BACKGROUND

To keep a wearer safe and comfortable, footwear is called upon to perform a variety of functions. For example, the sole structure of footwear should provide adequate support and impact force attenuation properties to prevent injury and reduce fatigue, while at the same time provide adequate flexibility so that the sole structure articulates, flexes, stretches, or otherwise moves to allow an individual to fully utilize the natural motion of the foot.

Despite the differences between the various footwear styles, sole structures for conventional footwear generally include multiple layers that are referred to as an insole, a midsole, and an outsole. The insole is a thin, cushioning member located adjacent to the foot that enhances footwear comfort. The outsole forms the ground-contacting element of footwear and is usually fashioned from a durable, wear resistant material that may include texturing or other features to improve traction.

The midsole forms the middle layer of the sole and serves a variety of purposes that include controlling potentially harmful foot motions, such as over pronation; shielding the foot from excessive ground reaction forces; and beneficially utilizing such ground reaction forces for more efficient toe-off. Conventional midsoles may include a foam material to attenuate impact forces and absorb energy when the footwear contacts the ground during athletic activities. Other midsoles may utilize fluid-filled bladders (e.g., filled with air or other gasses) to attenuate impact forces and absorb energy.

Although foam materials in the midsole succeed in attenuating impact forces for the foot, foam materials that are relatively soft may also impart instability that increases in proportion to midsole thickness. For example, the use of very soft materials in the midsole of running shoes, while providing protection against vertical impact forces, can encourage instability of the ankle, thereby contributing to the tendency for over-pronation. This instability has been cited as a contributor to "runner's knee" and other athletic injuries. For this reason, footwear design often involves a balance or tradeoff between impact force attenuation and stability.

Stabilization is also a factor in sports like basketball, volleyball, football, and soccer. In addition to running, an athlete may be required to perform a variety of motions including transverse movement; quickly executed direction changes, stops, and starts; movement in a backward direction; and jumping. While making such movements, footwear instability may lead to excessive inversion or eversion of the ankle joint, potentially causing an ankle sprain.

High-action sports, such as soccer, basketball, football, rugby, ultimate, etc., impose special demands upon players and their footwear. Accordingly, it would be desirable to provide footwear that achieves better dynamic control of the

2

wearer's movements, while at the same time providing impact-attenuating features that protect the wearer from excessive impact loads.

BRIEF SUMMARY

According to aspects of the invention, a sole structure of an article of footwear has a support assembly structure including a flexure element and an upper support element. The flexure element has a central portion located between first and second ground-contacting regions, wherein the central portion has a downwardly concavely-curved plate-like region. The flexure element also has first and second flanges extending upward from the first and second ground-contacting regions, respectively. The upper support element is positioned above the central portion and between the flanges of the flexure element. When a vertical compressive load is first applied to the upper support element, the upper support element moves vertically relative to the flanges.

According to other aspects, the upper support element may compress the downwardly concavely-curved plate-like region when a vertical compressive load is applied. During the application of the compressive load, the flanges may slidably interface with the upper support element, and the ground-contacting surfaces may move transversely relative to the downwardly concavely-curved plate-like region.

According to certain aspects, a plurality of legs may extend across the ground-contacting regions and further, may extend up into the flanges. The cutouts that define the legs may be transversely visible from the outside of the footwear.

The flexure element may have a recurved cross section, in which case an upwardly concavely-curved region will be located between the downwardly concavely-curved plate-like central region and one of the ground-contacting regions. Further, the flexure element may have a doubly-recurved cross-section, in which case an upwardly concavely-curved region will be located between the downwardly concavely-curved plate-like central region and each of the ground-contacting regions.

One or more gussets may be provided between the central portion and the flanges to stiffen the flexure element, in particular, to stiffen the flanges.

The support assembly structure may be located in a heel region and/or in a forefoot region of the sole structure.

According to another aspect of the invention, a support assembly structure includes a flexure element extending from a lateral-side ground-contacting region to a medial-side ground-contacting region. The flexure element includes a substantially planar central portion that is provided with a doubly-recurved cross-section. The flexure element also has flanges extending upward from the ground-contacting regions. The flanges may have legs and cutouts.

An article of footwear including an upper attached to the sole structure disclosed herein is also described herein.

BRIEF DESCRIPTION OF THE DRAWINGS

The foregoing Summary, as well as the following Detailed Description, will be better understood when read in conjunction with the accompanying drawings.

FIG. 1A is a side view, looking from the lateral side, of an article of footwear having an upper and a sole structure in accordance with aspects of this disclosure.

FIG. 1B is a rear view of the article of footwear of FIG. 1A.

3

FIG. 1C is a bottom view of the article of footwear of FIG. 1A.

FIG. 2A is a top perspective view of a flexure element in accordance with aspects of this disclosure.

FIG. 2B is a bottom perspective view of the flexure element of FIG. 2A.

FIG. 2C is a top view of the flexure element of FIG. 2A.

FIG. 2D is a bottom view of the flexure element of FIG. 2A.

FIG. 2E is a medial side view of the flexure element of FIG. 2A.

FIG. 2F is a front view of the flexure element of FIG. 2A.

FIG. 2G is a back view of the flexure element of FIG. 2A.

FIG. 3 is a schematic cross-section of a flexure element in accordance with aspects of this disclosure.

FIG. 4A is a top perspective view of a sole structure in accordance with aspects of this disclosure.

FIG. 4B is a bottom perspective view of the sole structure of FIG. 4A.

FIG. 4C is a back perspective view of the sole structure of FIG. 4A.

FIG. 4D is a lateral side perspective view of the sole structure of FIG. 4A.

FIG. 4E is a medial side perspective view of the sole structure of FIG. 4A.

FIG. 4F is an exploded top perspective view of the sole structure of FIG. 4A.

FIG. 5A is a top view of the upper support element of the sole structure of FIG. 4A.

FIG. 5B is a medial side view of the upper support element of FIG. 5A.

FIG. 6 is a top perspective view of a flexure element in accordance with other aspects of this disclosure.

FIG. 7 is a top perspective view of a flexure element in accordance with further aspects of this disclosure.

FIG. 8 is a top perspective view of a flexure element in accordance with certain aspects of this disclosure.

FIG. 9A is a top perspective view of a central layer of a flexure element in accordance with even other aspects of this disclosure.

FIG. 9B is a side perspective view of the top and bottom layers of a flexure element for use with the central layer of FIG. 9A.

FIG. 9C is a perspective view taken from the bottom of the top and bottom layers of a flexure element for use with the central layer of FIG. 9A.

FIG. 10 is a schematic bottom view of an article of footwear in accordance with aspects of this disclosure.

It should be understood that the appended drawings are not necessarily to scale, presenting a somewhat simplified representation of various features illustrative of specific aspects of the invention. Certain features of the illustrated embodiments may have been enlarged or distorted relative to others to facilitate visualization and clear understanding. In particular, thin features may be thickened, for example, for clarity of illustration.

DETAILED DESCRIPTION

The following discussion and accompanying figures disclose articles of footwear having sole structures with sole geometries in accordance with various embodiments of the present disclosure. Concepts related to the sole geometry are disclosed with reference to a sole structure for an article of athletic footwear. The disclosed sole structure may be incorporated into a wide range of athletic footwear styles, including shoes that are suitable for rock climbing, bouldering,

4

hiking, running, baseball, basketball, cross-training, football, rugby, tennis, volleyball, and walking, for example. In addition, sole structures according to various embodiments as disclosed herein may be incorporated into footwear that is generally considered to be non-athletic, including a variety of dress shoes, casual shoes, sandals, slippers, and boots. An individual skilled in the relevant art will appreciate, given the benefit of this specification, that the concepts disclosed herein with regard to the sole structure apply to a wide variety of footwear styles, in addition to the specific styles discussed in the following material and depicted in the accompanying figures.

Sports generally involve consistent pounding of the foot and/or periodic high vertical impact loads on the foot. Thus, a sole structure for an article of footwear having an impact-attenuation system capable of handling high impact loads may be desired. Additionally, however, many sports involve transverse movements that are separate from the movements that involve large vertical impact loads. It may be desirable to have a relatively soft transverse stiffness characteristic (for example, to aid in cutting), while at the same time having a robust vertical impact-attenuation characteristic. Optionally, it may be desirable to have a relatively unforgiving transverse stiffness characteristic (for example, to provide greater stability), while at the same time having a relatively compliant vertical impact-attenuation characteristic. Thus, it may be advantageous to have a sole structure that decouples the vertical stiffness characteristic from the transverse stiffness characteristic. Such a decoupled sole structure would provide a vertical stiffness response that is independent of (or relatively independent of) the transverse stiffness response. It may be advantageous to have such a decoupled sole structure located in the forefoot region of the footwear. It may be particularly advantageous to have such a decoupled sole structure located in the heel region of the footwear.

As noted above, according to certain aspects, it may be advantageous to have a sole structure that decouples the vertical stiffness characteristic from a side-to-side transverse stiffness characteristic. For certain specific applications, it may even be advantageous to have a sole structure that decouples the vertical stiffness characteristic from a front-to-back transverse stiffness characteristic.

Various aspects of this disclosure relate to articles of footwear having a sole structure with a support structure assembly designed to decouple its vertical stiffness characteristics from its transverse stiffness characteristics. Thus, according to certain embodiments, it would be desirable to tailor footwear to provide an optimum amount of protection against vertical impact loads, yet at the same time provide an optimum level of transverse flexibility/stability.

As used herein, the terms “upper,” “lower,” “top,” “bottom,” “upward,” “downward,” “vertical,” “horizontal,” “longitudinal,” “transverse,” “front,” “back,” “forward,” “rearward,” etc., unless otherwise defined or made clear from the disclosure, are relative terms meant to place the various structures or orientations of the structures of the article of footwear in the context of an article of footwear worn by a user standing on a flat, horizontal surface. “Transverse” refers to a generally sideways (i.e., medial-to-lateral or heel-to-toe) orientation (as opposed to a generally vertical orientation). “Lateral” refers to a generally medial-to-lateral (i.e., side-to-side) transverse orientation. “Longitudinal” refers to a generally heel-to-toe (i.e., front-to-back) transverse orientation. A “lateral roll” is characterized by upward and/or downward displacement of a medial side of a foot portion relative to a lateral side of the foot portion. A

“longitudinal roll” is characterized by upward and/or downward displacement of a forward end of a foot portion relative to a rearward end of the foot portion.

Referring to FIGS. 1A-1C, an article of footwear **10** generally includes two primary components: an upper **100** and a sole structure **200**. Upper **100** is secured to sole structure **200** and forms a void on the interior of footwear **10** for comfortably and securely receiving a foot. Sole structure **200** is secured to a lower portion of upper **100** and is positioned between the foot and the ground. Upper **100** may include an ankle opening that provides the foot with access to the void within upper **100**. As is conventional, upper **100** may also include a vamp area having a throat and a closure mechanism, such as laces.

Referring to FIG. 1C, typically, sole structure **200** of the article of footwear **10** has a forefoot region **11**, a midfoot region **12** and a heel region **13**. Although regions **11-13** apply generally to sole structure **200**, references to regions **11-13** may also apply to the article of footwear **10**, upper **100**, sole structure **200**, or an individual component within either sole structure **200** or upper **100**.

Sole structure **200** of the article of footwear **10** further has a toe or front edge **14** and a heel or back edge **15**. A lateral edge **17** and a medial edge **18** each extend from the front edge **14** to the back edge **15**. Further, sole structure **200** of the article of footwear **10** defines a longitudinal centerline **16** extending from the back edge **15** to the front edge **14** and located generally midway between the lateral edge **17** and the medial edge **18**. Longitudinal centerline **16** generally bisects sole structure **200**, thereby defining a lateral side and a medial side.

According to certain aspects and referring to FIGS. 1A-1C, sole structure **200** includes a forward portion **202** and a rearward portion **204**. Forward portion **202** may encompass forefoot region **11** and some or all of midfoot region **12**. Rearward portion **204** may encompass heel region **13** and some or all of midfoot region **12**. Thus, some portion of forward portion **202** and/or rearward portion **204** of sole structure **200** may be located in the midfoot region **12**. In this particular configuration, forward portion **202** includes a conventional midsole structure **220** and a conventional outsole structure **210**. Rearward portion **204** includes a support assembly structure **300**.

Referring to FIG. 1A, sole structure **200** may include multiple layers and/or multiple components. For example, forward portion **202** may include an outsole structure **210** and a midsole structure **220**, and may include an insole (not shown). Outsole structure **210** forms the ground-engaging portion (or other contact surface-engaging portion) of sole structure **200**, thereby providing traction and a feel for the engaged surface. Outsole structure **210** may also assist in providing stability and localized support for the foot. Even further, outsole structure **210** (and in some instances, insole) may assist in providing impact force attenuation capabilities.

Outsole structure **210** may be formed of conventional outsole materials, such as natural or synthetic rubber or a combination thereof. The material may be solid, foamed, filled, etc. or a combination thereof. One particular rubber for use in outsole structure **210** may be a solid rubber having a typical Shore A hardness of between 74-80. The rubber may be a natural rubber, a synthetic rubber or a combination thereof. As an example, a particular composite rubber mixture may include approximately 75% natural rubber and 25% synthetic rubber such as a styrene-butadiene rubber. Other suitable polymeric materials for the outsole structure include plastics, such as PEBAX® (a poly-ether-block copolyamide polymer available from Atofina Corporation of

Puteaux, France), silicone, thermoplastic polyurethane (TPU), polypropylene, polyethylene, ethylvinylacetate, and styrene ethylbutylene styrene, etc. Optionally, outsole structure **210** may also include fillers or other components to tailor its hardness, wear, durability, abrasion-resistance, compressibility, stiffness and/or strength properties. Thus, for example, outsole structure **210** may include reinforcing fibers, such as carbon fibers, glass fibers, graphite fibers, aramid fibers, basalt fibers, etc.

Further, outsole structure **210** may include a ground-contacting bottom layer. The ground-contacting bottom layer may be formed separately from the other portions of outsole structure **210** and subsequently integrated therewith. The ground-contacting bottom layer may be formed of an abrasion resistant material that may be co-molded, laminated, adhesively attached or applied as a coating to form a lower surface of outsole **210**.

Referring back to FIG. 1A, forward portion **202** of sole structure **200** also may include a midsole structure **220**. Midsole structure **220** may be positioned between outsole structure **210** and upper **100**. Midsole structure **220** may be secured to upper **100** along the lower length of the upper **100** in any conventionally known manner (e.g., via adhesive, stitching, co-molding, etc.).

In general, a conventional midsole structure may have a resilient, polymer foam material, such as polyurethane or ethylvinylacetate. The foam may extend throughout the length and width of the forward portion **202**. In general, a relatively thick foam layer will provide greater impact force attenuation than a relatively thin foam layer, but it will also have less stability than the relatively thin foam layer. Optionally, a midsole structure may incorporate sealed chambers, fluid-filled bladders, channels, ribs, columns (with or without voids), etc.

The optional insole (or sockliner), is generally a thin, compressible member located within the void for receiving the foot and proximate to a lower surface of the foot. Typically, the insole, which is configured to enhance footwear comfort, may be formed of foam, and optionally a foam component covered by a moisture wicking fabric or textile material. Further, the insole or sockliner may be glued or otherwise attached to the other components of sole structure **200**, although it need not be attached, if desired.

According to certain aspects and referring to FIGS. 1A-1C, rearward portion **204** of sole structure **200** includes support assembly structure **300**. According to certain aspects, support assembly structure **300** may decouple, or at least partially decouple, a vertical compressive stiffness characteristic from a lateral stiffness characteristic.

According to the particular embodiment illustrated in FIGS. 1A-1C, support assembly structure **300** may include a flexure element **320** and an upper support element **310**. Upper support element **310** is located above flexure element **320**. Further, upper support element **310** may be attached to a lower surface of upper **100**. Optionally, upper support element **310** may be attached to a midsole element **220**. Even further, upper support element **310** may be integrally (or even unitarily) formed with a midsole element **220**. Lower surfaces of flexure element **320** may form a portion of the ground-contacting surface of footwear **10**. Optionally, as described in more detail below, an outsole structure **210** may be positioned below flexure element **320**. In some embodiments, flexure element **320** may be attached to an upper surface of outsole structure **210**.

With particular reference to FIGS. 2A through 2G and FIG. 3, flexure element **320** may include a central portion **322**, a lateral flange **324** and a medial flange **326**. Central

portion **322** extends from a lateral lower edge **323** to a centrally located portion or region **321a** and then to a medial lower edge **325**. Region **321a** may have a downwardly concavely-curved shape. Central portion **322** is joined to flanges **324**, **326** at edges **323**, **325**, respectively. Lateral flange **324** extends upward in a generally vertical direction from lateral edge **323**. Medial flange **326** extends upward in a generally vertical direction from medial edge **325**. Flexure element **320** may have a constant thickness or portions of the flexure element **320** may be provided with a varying thickness so as to develop specific stiffness and/or strength characteristics.

As shown in the embodiment of FIGS. 1-3 and referring in particular to FIG. 3, lower edges **323** and **325** of flexure element **320** may be provided with ground-contacting surfaces **323a**, **325a**. Thus, in certain embodiments, lower edges **323**, **325** may be considered to be ground-contacting regions. The lateral ground-contacting region formed by lower edge **323** may extend along a lateral side of support assembly structure **300** (and of the article of footwear **10**). The medial ground-contacting region formed by lower edge **325** may extend along a medial side of support assembly structure **300** (and of the footwear **10**).

At a front edge of flexure element **320**, and referring in particular to FIGS. 1C and 2A-2F, a relatively flat portion or landing **328** may be provided. Central portion **322** may be separated from a leading edge **329** of landing **328** by a front cutout **332**. At a rear edge of flexure element **320** a platform **334** may be provided. Central portion **322** may be separated from platform **334** by a rear cutout **336**. Platform **334** may include a flange **335** for additional stiffness or strength. Landing **328** and/or platform **334** may provide a footprint for mounting (or attaching) flexure element **320** to the remainder of the sole structure **200**. In addition, landing **328** and/or platform **334** may provide a measure of front-to-rear rocking stability. Optionally, landing **328** and/or platform **334** may prevent or inhibit excessive splaying of the lower edges **323**, **325** when the center region of flexure element **320** is subjected to vertical compressive loading (F) (see FIG. 3).

Referring to FIGS. 2A-2G, flexure element **320** may be formed as a curved, generally shell-like element. For example, central portion **322** of flexure element **320** may be concavely-curved downward in a side-to-side lateral direction. Still referring to FIGS. 2A-2G, central portion **322** of flexure element **320** may be formed as a complexly-curved, generally shell-like element. For example, central portion **322** and in particular region **321a** may be concavely-curved downward in both a side-to-side lateral direction and a front-to-rear longitudinal direction. The degree of curvature may be the same or different in the two orthogonal, transverse directions. Similarly, central portion **322** may be convexly-curved upward in the side-to-side lateral direction and/or may be convexly-curved upward in the front-to-rear longitudinal direction. In addition, the upward facing surface of region **321a** may be flattened to provide a planar footprint for contacting upper support element **310**.

According to certain aspects and referring to FIG. 3, in the lateral side-to-side direction, flexure element **320** may be generally concavely-curved downward in central region **321a** and generally concavely-curved upward in side regions **321b**, **321c** adjacent at least one of the lateral lower edge **323** or medial lower edge **325**. Thus, for example, flexure element **320** may have a "recurved" or "S-shaped" cross-section as it extends in the lateral side-to-medial side direction. According to some aspects, flexure element **320** may be generally concavely-curved upward at both its lateral lower

edge **323** and at its medial lower edge **325**. Thus, flexure element **320** may have a "doubly-recurved" cross-section (much like a recurved bow) as it extends in the lateral direction.

Still referring to FIG. 3, when a sufficient force (F) is applied downward to the downwardly concavely-curved portion **321a** (for example, by the heel of a user's foot within the article of footwear), portion **321a** moves downward, lateral and medial lower edges **323**, **325** may splay or slide laterally outward, and the upper edges **324a**, **326a** of flanges **324**, **326** may move (or press) laterally inward.

One or more legs **330** may be provided where central portion **322** is joined to lateral and medial flanges **324**, **326**. In other words, lower edges **323** and **325** may be discontinuous due to cutouts **331**, such that a plurality of legs may extend across the lower-most ground-contacting regions. As illustrated in FIGS. 2A-2G, legs **330** may extend into and form part of central portion **322**. Further, legs **330** may extend into and form part of the generally vertically-oriented flanges **324**, **326**.

In FIGS. 2A-2G, a total of six legs **330** are illustrated, three each on the medial and lateral sides. Alternatively, any number of legs could be provided at the juncture of central portion **322** with lateral and medial flanges **324**, **326**. For example, a single leg may be provided on each side, multiple legs may be provided on each side with the same number of legs on each side, or multiple legs may be provided on each side with a different number of legs on each side. Each of legs **330** need not have the same length, width or thickness dimensions. According to some embodiments, a flexure element **320** having legs **330** may be considered to be a "spider" element. As shown in FIGS. 2A-2G, at the upper edge of flanges **324**, **326** the ends of legs **330** may be joined together. Optionally, one or more of the legs **330** may extend upward without being joined to the other legs **330**. Thus, in certain embodiments (not shown), each flange **324**, **326** may be formed as a plurality of distinct, individual legs **330**.

Upper support element **310** may be formed as a separate component, as a portion of midsole structure **220**, or as a portion of upper **100**. When formed as a separate element, upper support element **310** may be joined to midsole structure **220** and/or upper **100** as conventionally known in the art (e.g., via adhesives, thermal bonding, co-molding, stitching, etc.). Upper support element **310** provides a platform for a user's foot to bear on flexure element **320**.

As shown in FIGS. 1A-1C, upper support element **310** may extend from the rear edge **15** into the midfoot region **12** of footwear **10**. In this particular embodiment, upper support element includes a plate element **312** having lateral, medial and/or heel flanges **314** extending around the perimeter thereof. Plate element **312** may be generally horizontally oriented and may conform or generally conform to the corresponding contours of a user's foot. Lateral flanges **314a** and medial flange **314b** may extend all or part of the way along the side edges of plate element **312**. Heel flange **314c** may extend all or part of the way across the back edge of the heel. Thus, according to certain aspects, upper support element **310** may be formed as a heel cup. Flanges **314a**, **314b**, **314c** may be used to stabilize the user's foot and to provide an attachment surface to a vertical portion of the article of footwear. In addition, as discussed below, lateral flange **314a** and medial flange **314b** may contact and interact with flanges **324**, **326**, respectively, of flexure element **320**. Heel flange **314c** may be joined to platform **334** of flexure element **320** via a vertical columnar or plate-like element, for example, pillar **370**.

Upper support element **310** may also be joined at its front end to midsole **220**, to outsole **210**, and/or to a front end of flexure element **320** (e.g., landing **328**). As illustrated in FIG. 1A, the forward portion **316** of upper support element **310** curves downward to cradle a rear edge of midsole structure **210**. A rear portion **212** of outsole **210** extends beneath this forward portion **316** of upper support element **310** and is joined thereto. Additionally, in this particular embodiment, the forward portion **316** of upper support element **310** curls or extends backward so as to engage landing **328** of flexure element **320**. In this particular embodiment, the rear portion **212** of outsole **210** is positioned between forward portion **316** of upper support element **310** and landing **328** of flexure element **320**.

Thus, referring to the embodiment illustrated in FIGS. 1A-1C, flexure element **320** may be attached to the remainder of the article of footwear **10** (or the remainder of sole structure **200**) at the front end or landing **328** of flexure element **320**. In this instance, landing **328** is joined to a portion of the outsole structure **210** located in the midfoot region **12**. Flexure element **320** may be attached to outsole structure **210** (and/or optionally to other portions of sole structure **200**) in any suitable known fashion. Optionally, flexure element **320** may remain detached from outsole structure **210**.

As noted above and as illustrated in FIGS. 1A-1B, flexure element **320** may be attached to the remainder of footwear **10** at its back end. Specifically, platform **334** may be joined to a rearward portion of upper support element **310** with a column or pillar **370**. In this embodiment, platform **334** includes an elongated, curved flange **335** extending along the rear edge, such that platform **334** has an “angle-type” cross-section for improved stiffness. Pillar **370** may extend upward from platform **334** (from flange **335**) to join with the lower rear edge of upper support element **310** and/or optional to join with a rearward region of upper **100**. Pillar **370** may generally be located on the longitudinal axis **16** or otherwise approximately centered from side-to-side of the footwear **10**. Further, pillar **370** may be relatively flexible such that loads in the vertical compressive direction cause pillar **370** to flex and shorten such that the upper support element **310** may move relative to flexure element **320**. Referring also to FIG. 1C, cutouts **332** and **336** may function to decouple central portion **322** from landing **328** and/or platform **334** of flexure element **320** to the remainder of footwear **10**. Thus, if landing **328** and/or platform **334** are fixedly joined to the remainder of footwear, cutouts **332** and/or **336** serve to isolate central portion **322** from such hard attachment points.

Referring now also to the embodiment shown in FIGS. 4A-4F, sole structure **200** includes an outsole structure **210**, a midsole structure **220** and a support assembly structure **300**. In the particular embodiment of FIGS. 4A-4F, outsole structure **210** extends as a single, continuous layer from the front edge **14** to the back edge **15** of footwear **10**. Support assembly structure **300**, including upper support element **310** and flexure element **320**, is positioned on top of the rear portion of outsole structure **210**. Upper support element **310** extends from the lateral edge to the medial edge of heel region **13**. Further, upper support element **310** extends from the rearward edge of heel region **13** forward toward midfoot region **12**. Flexure element **320**, located below upper support element **310**, may be attached at its front end (e.g., at landing **328**) to outsole structure **210** in any known fashion. Similarly, flexure element **320** may be attached at its back end (e.g., at platform **334**) and/or at its sides (e.g., at lower edges **323**, **325**) to outsole structure **210** in any known fashion.

Additionally, the lower surface of the outsole structure **210** may be provided with a suitable ground engaging surface such that the desired traction of the outsole structure **210** (and thereby of the footwear) to the ground may be provided.

Optionally, one or more of the lower edges **323**, **325** (or portions thereof) of flexure element **320** may be in contact with the upper surface of outsole structure **210**, but may be free to slide relative to this upper surface. Thus, by judicious choice of materials, the frictional resistance to the lower edges **323**, **325** sliding relative to outsole structure **210** may be controlled. As non-limiting examples, suitable materials for the lower edges **323**, **325** of flexure element **320** may include natural and/or synthetic rubbers, such as a styrene-butadiene rubber or a nylon/rubber blend, PEBAX®, silicone, silicone blends, TPU, polypropylene, polyethylene, ethylvinylacetate, and styrene ethylbutylene styrene, etc. The material may be solid, foamed, filled, etc. Similarly, suitable materials for the upper surface of outsole structure **210** may include foamed or solid natural and/or synthetic rubbers, including styrene-butadiene rubber or nylon/rubber blends, PEBAX®, silicone, silicon blends, TPU, polypropylene, polyethylene, ethylvinylacetate, and styrene ethylbutylene styrene, etc. Coatings to enhance the relative coefficient of friction between flexure element **320** and outsole structure **210** may be applied to one or both sliding surfaces.

As illustrated in the embodiment of FIGS. 4A-4F, flexure element **320** need not be attached to upper support element **310** (or otherwise to the remainder of the footwear) at back edge **15**. For example, in this specific embodiment, there is no pillar (or other support) coupling the rearward portion of upper support element **310** with the rear platform **334** of flexure element **320**. Further, as illustrated in the particular embodiment of FIGS. 4A-4F, upper support element **310** extends into midfoot region **12** and is integrally formed (or optionally, co-molded) with a forward portion of midsole structure **220** located in forefoot region **11**.

Referring now to FIGS. 5A and 5B, upper support element **310** may be generally formed as a heel cup and may include a generally horizontal plate **312**, a lateral sidewall or flange **314a** and a medial sidewall or flange **314b**. Plate **312** may be substantially planar, and further, plate **312** may substantially follow the contour of the sole of a foot. Plate **312** may have a relatively constant thickness. Optionally (not shown), plate **312** may have a relatively thickened or built-up pad beneath a central load-bearing area of the heel of the user. In certain embodiments (not shown), a pad may be formed separately and subsequently integrated with or otherwise joined to plate **312**. Even further, as shown in FIG. 5B, upper support element **310** may include a positioning stub **311** on its lower surface for insertion into a complementary positioning recess (not shown) in the upper surface of flexure element **320**. Positioning stub **311** may facilitate assembly of the support assembly structure **300** and further may serve to retain upper support element **310** centered over flexure element **320**.

Still referring to FIGS. 5A and 5B, lateral sidewall flange **314a** of upper support structure **310** extends at least partially along the length of the lateral edge of plate **312** and projects upward from plate **312**. Similarly, medial sidewall flange **314b** extends at least partially along the length of the medial edge of plate **312**. Upper support element **310** may also include a back wall or heel flange **314c** that extends at least partially along the length of the back edge of plate **312**. Further, according to certain embodiments, lateral flange **314a**, heel flange **314c** and medial flange **314b** may be

joined together so as to form a single continuous wall around the heel region. Optionally (not shown), upper support element 310 may include flanges that project downward from plate 312.

As best shown in FIGS. 1A and 1B and in FIGS. 4A and 4D, upper support element 310 may be positioned above the central portion 322 of flexure element 320. In the unloaded configuration, the lower surface of plate 312 of upper support element 310 may be in contact with the upper convexly-curved surface of central portion 321a of flexure element 320. Alternatively, in the unloaded configuration, the lower surface of plate 312 of upper support element 310 may be positioned above and spaced from the upper convexly-curved surface of central portion 321a of flexure element 320.

Further, upper support element 310 may be positioned between flanges 324, 326 such that the lateral and medial outer side surfaces of upper support element 310 contact flanges 324, 326 of flexure element 320. Alternatively, in the unloaded configuration, the outer surface of lateral sidewall 314a of upper support element 310 may be spaced from the inner surface of lateral flange 324 of flexure element 320. Similarly, the medial surfaces of upper support element 310 and flexure element 320 may also be initially spaced apart (i.e., in the unloaded configuration). In any event, upper support element 310 may slidably engage or interface with flanges 324, 326 of flexure element 320 when a vertical compressive load is applied to upper support element 310.

Support assembly structure 300 has a multi-regime vertical stiffness characteristic. At different times during the application of a vertical compressive load, support assembly structure 300 provides different load paths as its components engage one another and/or as its individual components deflect and assume new configurations. When a user's foot applies a vertical compressive load to the portion of the footwear 10 in the region of upper support element 310, downward movement of upper support element 310 (and thus, also of upper 100) causes the lower surface of plate 312 to contact flexure element 320, if it is not already in contact, or to displace flexure element 320, if it is already in contact. This initial downward movement of upper support element 310 also results in a corresponding downward displacement of lateral and medial sidewall flanges 314a, 314b of upper support element 310 relative to lateral and medial flanges 324, 326, respectively, of flexure element 320. If the medial and/or lateral sidewalls of upper support element 310 and the medial and/or lateral flanges of flexure element 320 are in contact during this relative downward displacement, then a vertical frictional resistance is developed. Further downward displacement of upper support element 310 may cause plate 312 to bear down against the top surface of central portion 321 of flexure element 320. This may cause the concavely-curved portion 321a of flexure element 320 to start to flatten out, while at the same time the lower lateral and medial edges 323, 325 of flexure element 320 may start to displace laterally outward (i.e., away from the longitudinal centerline 16). As flexure element 320 flattens out and edges 323, 325 move (or splay) outward, the recurved geometry of flexure element 320 may cause the upper edges 324a, 326a of flanges 324, 326 to move inward (i.e., toward the longitudinal centerline 16). This may result in a gripping or clamping load being applied by flexure element 320 to the lateral and medial sidewalls of upper support element 310. In turn, this may result in an increased resistance between upper support element 310 and flanges 324, 326 to relative vertical displacement of upper support element 310 and flexure element 320. Further, this also may result in a

stiffening of central portion 322 as the lateral clamping of the upper edges 324a, 326a of flanges 324, 326 against upper support element 310 stops or inhibits the inward rotation of the flanges 324, 326 and therefore, limits further outward movement of the lower lateral and medial edges 323, 325. Thus, additional downward motion of upper support element 310 may meet with further resistance (i.e., an increased stiffness) due to the reluctance of the concavely-curved portion 321a to continue to flatten out and the inhibition of the outward movement of the lower edges 323, 325.

As noted above, during the application of a vertical compressive load lateral sidewall flange 314a of upper support element 310 may interact with lateral flange 324 of flexure element 320, and similarly, medial sidewall flange 314b of upper support element 310 may interact with medial flange 326 of flexure element 320. In the embodiment of FIGS. 4A-4F and as best shown in FIGS. 4C and 5B, lateral sidewall 314a of upper support element 310 may include an outer surface 315a that complementarily engages inner surface 324b of lateral flange 324 of flexure element 320, and similarly, medial sidewall 314b of upper support element 310 includes an outer surface 315b that complementarily engages with inner surface 326b of medial flange 326 of flexure element 320. According to some embodiments, one or both of the outer surfaces 315a, 315b of the lateral and medial sidewalls 314a, 314b of upper support element 310 may be canted, i.e., the outer surfaces may be formed as slightly off-vertical surfaces angling upward and outward. These angled or canted surfaces 315a, 315b may provide a sliding surface for the upper edges of flanges 324, 326 of flexure element 320, wherein the sliding resistance increases the more that the upper support element 310 moves downward relative to the flexure element 320. Optionally, one or both of the outer surfaces 315a, 315b may also be formed with stops (not shown) that limit the downward motion of the upper support element 310 relative to the flexure element 320. Such stops may be formed as protruding ridges or overhangs on the outer surfaces of the medial sidewalls 314a, 314b. Thus, as a vertical compressive load is applied in the heel region 13, upper support element 310 (along with upper 100) moves vertically relative to flanges 324 and 326 of flexure element 320. As described above, this vertical motion of upper support element 310 relative to flexure element 320 may be accompanied by a sliding and/or clamping contact between sidewall 314a and flange 324 and/or sidewall 314b and flange 326. After a certain predetermined amount of relative vertical displacement has occurred, further motion may be limited by a stop.

In certain embodiments, under increased vertical compressive load, the downwardly concavely-curved portion 321a of flexure element 320 may elastically buckle. For purposes of this disclosure, "buckling" refers to the occurrence of a relatively large deflection of a structure subjected to a compression load upon a relatively small increase in the compression load. Such buckling may include "snap-through" behavior and may occur when the lower edges 323, 325 are prohibited from sliding outward, yet at the same time, the upper support element 310 continues to press down on the top of the concavely-curved portion 321a.

Support assembly structure 300 not only has a multi-regime vertical stiffness characteristic, but it also has a multi-regime lateral stiffness characteristic. When a user's foot applies a lateral load to the portion of the footwear 10 in the region of upper support element 310 (such as when a cutting action takes place) sideways or lateral movement of upper support element 310 (and thus, also of upper 100)

causes the one of the lateral surfaces of upper support element 310 to contact the corresponding flange (324 or 326) of flexure element 320, if it is not already in contact. This initial lateral movement of upper support element 310 is generally accompanied by a vertical compressive load and the corresponding relative displacements discussed above with respect to upper support element 310 and flexure element 320. As the upper support element 310 laterally presses or bears against the inner surface of the corresponding flange (324 or 326) of the flexure element 320, the flange cantilevers outward. This outward cantilevering of the flange results in a corresponding load on the lower edge of the flange, such that the lower edge of the flange attempts to move inward (toward the longitudinal axis 16). Generally, however, the lower edge of the flange will be in contact with the ground (or the outsole 210), and further, due to the accompanying vertical load, the lower edge of this laterally loaded flange may be pressed firmly against the ground such that no inward motion could occur. Thus, lateral loads may be primarily reacted by the cantilever bending of the loaded vertical load causes flanges 324, 326 of flexure element 320 to engage and press against upper support element 310, as described above, the flange on the opposite side of the loading direction may also carry some of the lateral load. In other words, it is expected that lateral loads applied to upper support element 310 are reacted by bending of flanges 324, 326 of flexure element 320, with the majority of the load reacted by the flange bent outward.

From the above discussion, it becomes apparent that the load paths for reacting vertical compressive loads and lateral loads are essentially decoupled. Thus, for example, flexure element 320 of support assembly structure 300 may be designed with a stiff central portion 322 and relatively flexible flanges 324, 326 in bending. When greater lateral stability is desired, a flexure element 320 could be provided with the same central portion 322, but with much stiffer flanges 324, 326.

According to certain aspects and referring back to FIGS. 2A-2G, relatively stiff flanges 324, 326 could be provided by increasing the thickness of the flanges, increasing the stiffness of the material used to form the flanges, and/or decreasing the active height of the flanges (i.e., the distance from where the flanges 324, 326 contact the upper support element 310 to the lower surface of the flexure element 320). Conversely, relatively flexible flanges 324, 326 could be provided by decreasing the thickness of the flanges, decreasing the stiffness of the material used to form the flanges, and/or increasing the active height of the flanges. Further, providing cutouts in the flanges 324, 326 such that the lower edges 323, 325 become discontinuous and a plurality of legs 330 are provided will also decrease the stiffness of the flanges 324, 326. Even further, should the cutouts extend all the way to the upper edges 324a, 326a of the flanges, the ends of the legs 330 would not be joined together and this may also decrease the bending stiffness of the flanges 324, 326.

According to certain aspects, one or more gussets 360 may be provided to develop additional stiffness of the flexure element flanges 324, 326. Referring, for example, to FIGS. 2A, 2C, 2F and 2G, gussets 360 are shown extending between central portion 322 and flanges 324, 326. Specifically, in the illustrated embodiment, three gussets 360 are provided on the lateral side and three gussets 360 are provided on the medial side of flexure element 320. Optionally, just a single gusset 360 could be provided on each side; just a single gusset 360 could be provided on just one side

with fewer or more gussets 360 provided on the other side; two gussets 360 could be provided on each side; two gussets 360 could be provided on one side with fewer or more gussets 360 provided on the other side; etc. Thus, any number of gussets 360 may be provided in each side (including no gussets).

Further, the gussets 360 need not have the same dimensions. Depending upon the degree of additional stiffness desired, the cross-sectional area of the individual gussets 360 could be the same, less than or greater than other gussets. For example, increasing the height of any individual gusset 360 would increase the stiffness of the attachment of the flange to central portion 322. Further, gussets 360 need not extend all the way down to the interior angle formed between the central portion 322 and the flanges 324, 326. Thus, optionally (not shown), gussets 360 may be formed as bridges extending from the central portion 322 to a flange 324, 326 and spanning the interior angle formed between the central portion 322 and the flange 324, 326.

According to further aspects and as illustrated in FIG. 6, flexure element 320 may be formed without leg cutouts (see cutouts 331 in FIG. 2A), without a front cutout (see cutout 332 in FIG. 2A) and/or without a rear cutout (see cutout 336 in FIG. 3A). According to other aspects and as illustrated in FIG. 7, flexure element 320 need not include gussets (see gussets 360 in FIG. 2A), although such a flexure element 320 could include leg cutouts (not shown in FIG. 7). Thus, in certain embodiments, flexure element 320 may include a central portion 322, a lateral flange 324 and a medial flange 326. The central portion 322 may be formed as a doubly-recurved plate in the lateral (side-to-side) direction. Flanges 324, 326 extend upward in a generally vertical direction from the lower lateral edges 323, 325 of central portion 322.

According to even other aspects and as illustrated in FIG. 8, flexure element 320 need not include a landing at its front end (see landing 328 in FIG. 2A) or even a platform at its rear end (see platform 334 in FIG. 2A). In such case, flexure element 320 would not be secured at its front end to the remainder of sole structure 200, nor would it be secured at its rear end with a pillar to upper support element 310.

Alternative attachment means may be used to attach flexure element 320 to the remainder of footwear 10. For example, pillar 370 may be secured to either flexure element 320 or upper support element 310, but not both. Relative compressive displacement between flexure element 320 and upper support element 310 could result in pillar 370 coming under load after a predetermined amount of relative displacement between upper support element 310 and flexure element 320. As another example embodiment, flanges 324, 326 may be clipped onto (or otherwise attached to) the lateral and medial sides of upper support element 310 such that relative vertical displacement between flanges 324, 326 and upper support element 310 is allowed during vertical compressive loading. In a "no-load" configuration, complementary clip elements would keep the flexure element 320 attached to upper support element 310. For example, flanges 324, 326 may be slidably coupled to upper support element 310 with a pin-in-groove (or other sliding element movable along a track) mechanism. As even another option, upper support element 310 may be provided with downwardly open channels along its lateral and medial sides, with the channels configured to slidably receive flanges 324, 326 or portions thereof. Various attachment means may be used in combination.

Flexure element 320 may be formed of a relatively lightweight, relatively stiff material. For example, flexure element 320 may be formed of polymeric materials, such as

PEBAX® (a poly-ether-block co-polyamide polymer available from Atofina Corporation of Puteaux, France), silicone, thermoplastic polyurethane (TPU), polypropylene, polyethylene, ethylvinylacetate, and styrene ethylbutylene styrene, etc. One particular material for use in flexure element **320** may be a nylon/rubber blend, such as a nylon-6/rubber blend. As non-limiting examples, nylon/rubber blends may include nylon/EPDM (ethylene propylene diene monomer) rubber, nylon/EPM (ethylene propylene monomer) rubber, nylon/polypropylene, nylon/polyethylene (LDPE), nylon/poly(butadiene), etc. Optionally, the material of flexure element **320** may also include fillers or other components to tailor its hardness, wear, durability, abrasion-resistance, compressibility, stiffness and/or strength properties. Thus, for example, flexure element **320** may include reinforcing fibers, such as carbon fibers, glass fibers, graphite fibers, aramid fibers, basalt fibers, etc. Even further, flexure element **320** may include one or more metal elements or subcomponents. Such metal subcomponents may be particularly suitable in high stress, high strain areas of the flexure element **320**. Other materials, as would be apparent to persons of ordinary skill in the art as suitable for the flexure element **320**, given the benefit of this disclosure, may be provided.

Further, flexure element **320** may be formed of multiple materials. According to certain aspects, flexure element **320** may be formed of more than one layer, wherein the different layers may be formed of different materials. Referring to FIGS. 2A-2B and also to FIG. 4F, flexure element **320** may be formed of three layers, a central layer **350**, a top layer **352** and a bottom layer **354**. An example embodiment of a central layer **350** is shown in FIG. 9A. In this embodiment, central layer **350** includes a central portion **322'**, a lateral flange **324'** and a medial flange **326'**. Central portion **322'** extends from a lateral lower edge **323'** to a centrally located downwardly concavely-curved portion or region **321a'** and then to a medial lower edge **325'**. Central portion **322'** is joined to flanges **324'**, **326'** at edges **323'**, **325'**, respectively. A relatively flat portion or landing **328'** and a front cutout **332'** is provided. At the rear edge, a platform **334'** and a rear cutout **336'** is provided. Central layer **350** may be formed by any suitable method, including injection molding, compression molding, etc.

An example embodiment of the top layer **352** and the bottom layer **354** is shown in FIGS. 9B and 9C. In these figures, top layer **352** and bottom layer **354** are shown as a single component which would be co-molded on opposite sides of central layer **350**. Top layer **352** and bottom layer **354** may be formed of a different material than central layer **350** and of the same or different material from each other. According to some aspects, the material of central layer **350** may be harder and stiffer than the material(s) of top layer **352** and/or bottom layer **354**. In general, layers **350**, **352**, **354** may be formed of any conventional midsole and/or outsole materials, including natural or synthetic rubber or a combination thereof. The material may be solid, foamed, filled, etc. or a combination thereof. By way of non-limiting examples, suitable polymeric materials for layers **352**, **354** may include materials as listed above for flexure element **320**. According to certain embodiments, one or both of top layer **352** and bottom layer **354** may be co-molded or over-molded with central layer **350**. Alternatively, one or both of top layer **352** and bottom layer **354** may be molded separately from central layer **350** and subsequently attached thereto. In some embodiments, flexure element **320** may be formed of a plurality of layers, wherein at least a portion of

at least two of the plurality of layers are visible from an exterior of the article of footwear.

Optionally, flexure element **320** may be formed of a single material as a single layer. In general, flexure element **320** may be formed of any number of layers and of any number of materials. Further, flexure element **320** and/or layers **350**, **352**, **354** need not be integrally formed. For example, portions of flexure element **320** and/or portions of layers **350**, **352**, **354** may be separately formed and subsequently joined to each other to form a unitary component.

Even further, along the lower edges **323**, **325** of flexure element **320**, a ground-contacting layer may be provided. Ground-contacting layer may include any suitable material as known to persons of skill in the art. Further, ground-contacting layer may be applied or secured to flexure element **320** in any conventionally known fashion. Alternatively, along the lower edges **323**, **325** a material suitable for sliding on a top surface of an outsole portion may be applied to flexure element **320**.

Similar to flexure element **320**, upper support element **310** may be formed of a relatively lightweight, relatively stiff material. For example, upper support element **310** may be formed of conventional midsole and/or outsole materials, such as natural or synthetic rubber or a combination thereof. The material may be solid, foamed, filled, etc. or a combination thereof. One particular rubber for use in upper support element **310** may be a solid rubber having a typical Shore A hardness of between 74-80. The rubber may be a natural rubber, a synthetic rubber or a combination thereof. As an example, a particular composite rubber mixture may include approximately 75% natural rubber and 25% synthetic rubber such as a styrene-butadiene rubber. By way of non-limiting examples, other suitable polymeric materials for upper support element **310** include plastics, such as PEBAX® (a poly-ether-block co-polyamide polymer available from Atofina Corporation of Puteaux, France), silicone, thermoplastic polyurethane (TPU), polypropylene, polyethylene, ethylvinylacetate, and styrene ethylbutylene styrene, etc. Optionally, the material of upper support element **310** may also include fillers or other components to tailor its hardness, wear, durability, coefficient of friction, abrasion-resistance, compressibility, stiffness and/or strength properties. Thus, for example, upper support element **310** may include reinforcing fibers, such as carbon fibers, glass fibers, graphite fibers, aramid fibers, basalt fibers, etc.

Gussets **360** may be integrally formed with flexure element **320** of the same material as flexure element **320**. Optionally, gussets **360** may be formed separately from the central portion **322** and the flanges **324**, **326** of flexure element **320**. For example, gussets **360** may be co-molded with flexure element **320** (or any of its layers **350**, **352**, **354**) or adhesively secured to the remainder of flexure element **320**. Even further, gussets **360** may include a metal (or other relatively strong, flexible material) as a skeleton, around which the polymeric materials of flexure element **320** are co-molded or otherwise formed and secured.

According to even other aspects of this disclosure and as shown in FIG. 10, a support assembly structure **300** may be provided in the forefoot region **11** of the article of footwear **10**. In this particular embodiment, flexure element **320** includes a rear platform **334**, but not a front landing **328**. Further, on the medial side, only one cutout **331** and two legs **330** are provided, whereas on the lateral side, two cutouts **331** and three legs **330** are provided.

In such an embodiment, it is expected that the overall height of the support assembly structure **300** provided in the forefoot region **11** would typically be less than that of a

support assembly structure **300** provided in the heel region **13**. By way of non-limiting examples, the height of the central portion **322** (as measured from the ground contacting surface of the lower edges **323**, **325** to the surface that contacts plate **312** of upper support element **310**) of a support assembly structure **300** provided in the heel region **13** may range from approximately 10.0 mm to approximately 30.0 mm, from approximately 15.0 mm to approximately 30.0 mm or from approximately 20.0 mm to approximately 30.0 mm. For comparison purposes, the height of the central portion **322** of a support assembly structure **300** provided in the forefoot region **13** may range from approximately 5.0 mm to approximately 15.0 mm, from approximately 8.0 mm to approximately 15.0 mm or from approximately 10.0 mm to approximately 15.0 mm.

Thus, from the above disclosure it can be seen that the decoupled (or partially decoupled) vertical and lateral stiffness characteristics of sole structure **200** due to support assembly structure **300** may provide improved vertical impact protection, while still achieving the desired degree of stability (or, alternatively, flexibility) for a wearer of the article of footwear.

The performance characteristics of the support assembly structure are primarily dependent upon factors that include the dimensional configurations of flexure element **320** and the properties of the material selected for the flexure element. By designing flexure element **320** to have specific dimensions and material properties, cushioning and stability of the footwear may be generally tuned to meet the specific demands of the activity for which the footwear is intended to be used. For walking shoes, for example, the dimensional and material properties of flexure element **320** may be selected to provide a medium degree of vertical impact force attenuation with a high degree of lateral stability. For running shoes, the impact-attenuating properties of the central portion **322** of the flexure element **320** may be enhanced, while still maintaining a relatively high degree of lateral stability. As another example, the dimensional and material configuration of the flanges **324**, **326** and/or the legs **330** of the flexure element **320** may also be selected to provide an even greater degree of lateral stability in basketball shoes.

In general, the dimensional and material properties of central portion **322** of flexure element **320** will be selected to accommodate expected vertical impact loads and to provide a generally preferred degree of impact-attenuation for a particular activity, while the dimensional and material properties of flanges **324**, **326** of flexure element **320** will be selected to provide the preferred degree of lateral stability and/or lateral motion control. Thus, the disclosed support assembly system allows the sole structure **200** to be tailored to the specific application.

Even further, additional components or elements may augment support assembly structure **300**. For example, foamed or solid elements of elastically compressible material (not shown) may be placed within the support assembly structure **300**. Other augmenting elements may include air bags and/or filled/unfilled pillows of any of various shapes and firmness. Even other augmenting elements may include spring elements and/or stiffeners. Such augmenting elements may serve to attenuate impact loads, to stabilize portions of the support assembly structure **300**, to store and return energy and/or to prevent debris from fouling the support assembly structure **300**. For example, foam elements may encapsulate or partially encapsulate one or more of the individual components of the support assembly structure **300**. Alternatively, augmenting elements may extend between one or more of the individual components of the

support assembly structure **300** and/or be integrally joined to one or more of the individual components of the support assembly structure **300**.

While the invention has been described with respect to specific examples including presently preferred modes of carrying out the invention, those skilled in the art, given the benefit of this disclosure, will appreciate that there are numerous variations and permutations of the above described structures, systems and techniques that fall within the spirit and scope of the invention as set forth above. Thus, for example, a wide variety of materials, having various properties, i.e., flexibility, hardness, durability, etc., may be used without departing from the invention. Finally, all examples, whether preceded by "for example," "such as," "including," or other itemizing terms, or followed by "etc.," are meant to be non-limiting examples, unless otherwise stated or obvious from the context of the specification.

We claim:

1. A sole structure of an article of footwear, the sole structure comprising:

a flexure element defining a lowermost surface of the article of footwear and having:

- (a) a central portion located between a first ground-contacting region and a second ground-contacting region, the central portion having a downwardly concavely-curved plate region, and
- (b) first and second flanges extending upward from the first and second ground-contacting regions, respectively; and

an upper support element positioned above the central portion, between the first and second flanges of the flexure element, and below upper edges of the first and second flanges of the flexure element, and below upper edges of the first and second flanges of the flexure element,

wherein the upper support element is configured to move vertically relative to the first and second flanges when a vertical compressive load is first applied to the upper support element, and

wherein the central portion, the first ground-contacting region, the second ground-contacting region, and the first and second flanges are integrally formed of a single material as a single layer.

2. The sole structure of claim 1, wherein the upper support element is configured to compress the downwardly concavely-curved plate region of the flexure element when a vertical compressive load is applied to the upper support element.

3. The sole structure of claim 1, wherein the first and second flanges are configured to slidably interface with the upper support element when a vertical compressive load is first applied to the upper support element.

4. The sole structure of claim 1, wherein at least one of the first and second ground-contacting regions moves transversely relative to the downwardly concavely-curved plate region when a vertical compressive load is first applied to the downwardly concavely-curved plate region of the flexure element.

5. The sole structure of claim 1, wherein the downwardly concavely-curved plate region is dome-shaped.

6. The sole structure of claim 1, wherein the first ground-contacting region extends along a lateral side of the sole structure and the second ground-contacting region extends along a medial side of the sole structure.

7. The sole structure of claim 1, wherein a plurality of legs extends across at least one of the first and second ground-contacting regions.

19

8. The sole structure of claim 1, wherein at least one of the first and second flanges includes at least one cutout that is transversely visible from an exterior of the article of footwear.

9. The sole structure of claim 1, wherein the flexure element includes an upwardly concavely-curved region between the downwardly concavely-curved plate region and one of the first and second ground-contacting regions.

10. The sole structure of claim 1,

wherein the flexure element includes a first upwardly concavely-curved region between the downwardly concavely-curved plate region and the first ground-contacting region, and

wherein the central portion includes a second upwardly concavely-curved region between the downwardly concavely-curved plate region and the second ground-contacting region.

11. The sole structure of claim 10, wherein at least one of the first and second upwardly concavely-curved regions includes at least one cutout that is visible from a bottom exterior of the article of footwear.

12. The sole structure of claim 1, wherein at least one gusset extends between the central portion and one of the first and second flanges.

13. The sole structure of claim 1, further comprising at least one additional layer positioned on the flexure element, wherein at least a portion of at least two of the flexure element and the at least one additional layer are visible from an exterior of the article of footwear.

14. The sole structure of claim 1, wherein the flexure element includes at least one of a front end and a rear end configured for attachment to a remainder of the sole structure.

15. The sole structure of claim 14, wherein the at least one of the front end and the rear end configured for attachment to a remainder of the sole structure includes a cutout.

16. The sole structure of claim 1, wherein the flexure element is positioned in a heel region of the sole structure.

17. The sole structure of claim 1, wherein the flexure element is positioned in a forefoot region of the sole structure.

18. A support assembly structure for an article of footwear, the support assembly structure comprising:

a flexure element defining a lowermost surface of the article of footwear, having a lateral side and a medial side, and extending from a first ground-contacting region extending along the lateral side to a second ground-contacting region extending along the medial side,

the flexure element having a central portion extending from the lateral to the medial side, the central portion having a doubly-recurved cross-section, and

the flexure element having first and second flanges extending upward from the first and second ground-contacting regions, respectively,

the central portion having a central area that is downwardly concave and edges that curve upwardly to define the first and second ground-contacting regions and that continue upwardly into the first and second flanges,

wherein the central portion, the first ground-contacting region, the second ground-contacting region, and the first and second flanges are integrally formed of a single material as a single layer.

19. The support assembly structure of claim 18, wherein at least one of the first and second flanges has a plurality of legs.

20

20. The support assembly structure of claim 19, wherein the plurality of legs extends across at least one of the first and second ground-contacting regions.

21. The support assembly structure of claim 18, wherein the flexure element has at least one gusset extending from the central portion to one of the first and second flanges.

22. The support assembly structure of claim 18, further comprising an upper support element positioned above the central portion and between the first and second flanges of the flexure element.

23. An article of footwear comprising:

an upper and a sole structure, the sole structure including a support assembly structure having a flexure element and an upper support element;

the flexure element defining a lowermost surface of the article of footwear and having:

a central portion located between a first ground-contacting region and a second ground-contacting region, the central portion having a downwardly concavely-curved plate region, and

first and second flanges extending upward from the first and second ground-contacting regions, respectively; and

the upper support element positioned above the central portion, between the first and second flanges of the flexure element, and below upper edges of the first and second flanges of the flexure element,

wherein the upper support element is configured to move vertically relative to the first and second flanges when a vertical compressive load is first applied to the upper support element, and

wherein the central portion, the first ground-contacting region, the second ground-contacting region, and the first and second flanges are integrally formed of a single material as a single layer.

24. The article of footwear of claim 23, wherein the upper support element is configured to compress the downwardly concavely-curved plate region of the flexure element when a vertical compressive load is applied to the upper support element.

25. The article of footwear of claim 23, wherein the first and second flanges are configured to slidably interface with the upper support element when a vertical compressive load is first applied to the upper support element.

26. The article of footwear of claim 23, wherein at least one of the first and second ground-contacting regions moves transversely relative to the downwardly concavely-curved plate region when a vertical compressive load is first applied to the downwardly concavely-curved plate region of the flexure element.

27. The article of footwear of claim 23, wherein the first ground-contacting region extends along a lateral side of the sole structure and the second ground-contacting region extends along a medial side of the sole structure.

28. The article of footwear of claim 23, wherein a plurality of legs extends across at least one of the first and second ground-contacting regions.

29. The article of footwear of claim 23, wherein at least one of the first and second flanges includes at least one cutout that is transversely visible from an exterior of the article of footwear.

30. The article of footwear of claim 23, wherein the flexure element includes an upwardly concavely-curved region between the downwardly concavely-curved plate region and one of the first and second ground-contacting regions.

31. The article of footwear of claim 23, wherein the flexure element includes a first upwardly concavely-curved region between the downwardly concavely-curved plate region and the first ground-contacting region, and

wherein the central portion includes a second upwardly concavely-curved region between the downwardly concavely-curved plate region and the second ground-contacting region.

32. The article of footwear of claim 23, wherein at least one gusset extends between the central portion and one of the first and second flanges.

33. The article of footwear of claim 23, further comprising at least one additional layer positioned on the flexure element, wherein at least a portion of at least two of the flexure element and the at least one additional layer are visible from an exterior of the article of footwear.

34. The article of footwear of claim 23, wherein the flexure element includes at least one of a front end and a rear end configured for attachment to a remainder of the sole structure.

35. The article of footwear of claim 34, wherein the at least one of the front end and the rear end configured for attachment to a remainder of the sole structure includes a cutout.

36. The article of footwear of claim 23, wherein the support assembly structure is positioned in a heel region of the sole structure.

* * * * *