



US009629379B2

(12) **United States Patent**  
**Lown**

(10) **Patent No.:** **US 9,629,379 B2**  
(45) **Date of Patent:** **\*Apr. 25, 2017**

- (54) **METHOD OF PREPARING ICED TEA**
- (71) Applicant: **Takeya USA Corporation**, Huntington Beach, CA (US)
- (72) Inventor: **John M. Lown**, Huntington Beach, CA (US)
- (73) Assignee: **Takeya USA Corporation**, Huntington Beach, CA (US)
- (\* ) Notice: Subject to any disclaimer, the term of this patent is extended or adjusted under 35 U.S.C. 154(b) by 128 days.  
  
This patent is subject to a terminal disclaimer.

(21) Appl. No.: **14/318,268**

(22) Filed: **Jun. 27, 2014**

(65) **Prior Publication Data**  
US 2014/0308415 A1 Oct. 16, 2014

**Related U.S. Application Data**  
(63) Continuation of application No. 13/041,117, filed on Mar. 4, 2011, now Pat. No. 8,778,432.

(51) **Int. Cl.**  
*A23F 3/18* (2006.01)  
*A23F 3/00* (2006.01)  
*A47J 31/06* (2006.01)

(52) **U.S. Cl.**  
CPC ..... *A23F 3/18* (2013.01); *A23F 3/00* (2013.01); *A47J 31/06* (2013.01)

(58) **Field of Classification Search**  
CPC ..... *A23F 3/00*; *A23F 3/18*; *A23F 3/06*  
See application file for complete search history.

- (56) **References Cited**
- U.S. PATENT DOCUMENTS
- 2,055,096 A 9/1936 Dehn et al.
- D102,574 S 12/1936 Nelson
- D110,140 S 6/1938 Gamble
- D121,154 S 6/1940 Bernhardt
- 2,257,944 A 10/1941 Fischbein
- D157,795 S 3/1950 Schwarz
- 2,505,305 A 4/1950 Schaefer
- D203,211 S 12/1965 Brocken et al.
- (Continued)

- FOREIGN PATENT DOCUMENTS
- CN 201398776 \* 2/2010
- CN 201658143 12/2010
- (Continued)

- OTHER PUBLICATIONS
- English Translation for JP 2011006088 published Jan. 13, 2011.\*
- (Continued)

*Primary Examiner* — Anthony Weier  
(74) *Attorney, Agent, or Firm* — Klein, O'Neill & Singh, LLP

(57) **ABSTRACT**  
A method for brewing and chilling a brewed beverage such as tea includes brewing the beverage; combining the brewed beverage with a chilling medium; and covering the combined brewed beverage and chilling medium with an airtight lid assembly to form an airtight seal. The combined brewed beverage and chilling medium may then be agitated. The airtight seal traps vapor generated from the beverage during the chilling, thereby causing the vapor to re-enter the beverage to maintain optimum flavor.

**24 Claims, 6 Drawing Sheets**

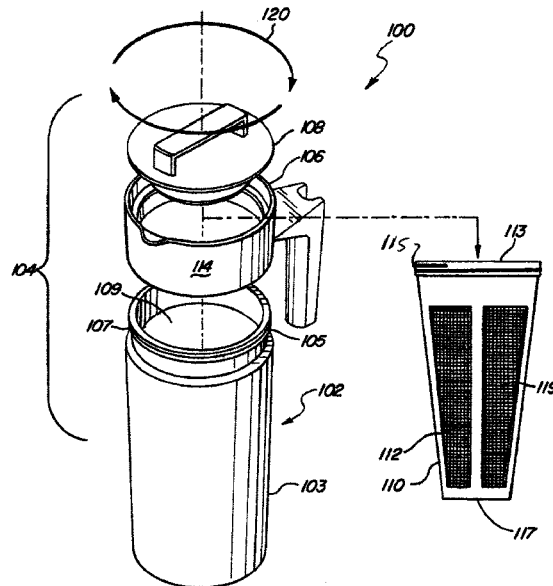

(56)

References Cited

U.S. PATENT DOCUMENTS

3,463,947 A 8/1969 Taylor  
 D216,370 S 12/1969 Hing et al.  
 3,844,450 A 10/1974 Johnson  
 4,276,992 A 7/1981 Susich  
 D264,926 S 6/1982 McClelland  
 4,473,470 A 9/1984 Loutit  
 4,487,114 A 12/1984 Abdenour  
 4,492,323 A 1/1985 Essen  
 D286,967 S 12/1986 Appel  
 D301,296 S 5/1989 Hsu  
 D302,370 S 7/1989 Gibert  
 D306,547 S 3/1990 Wolfenden  
 D308,460 S 6/1990 Balzano  
 D313,726 S 1/1991 Scherer  
 D316,206 S 4/1991 Daenen et al.  
 D319,368 S 8/1991 Picozza et al.  
 D320,350 S 10/1991 Fabiano  
 D321,301 S 11/1991 Purkapile  
 D325,687 S 4/1992 Embree  
 D338,367 S 8/1993 Fonville  
 5,231,918 A 8/1993 Grzywna  
 5,318,791 A 6/1994 Millman et al.  
 5,363,745 A 11/1994 Lin  
 5,477,979 A 12/1995 Goessling et al.  
 5,531,353 A 7/1996 Ward et al.  
 5,613,616 A 3/1997 Monus  
 5,678,472 A 10/1997 Millman  
 5,680,951 A 10/1997 Feltman, III et al.  
 5,738,786 A 4/1998 Winnington-Ingram  
 5,855,160 A 1/1999 Shen  
 5,862,739 A 1/1999 Lin  
 D406,011 S 2/1999 Hatsumoto et al.  
 5,913,964 A 6/1999 Melton  
 5,943,946 A 8/1999 Chen  
 5,947,004 A 9/1999 Huang  
 D427,846 S 7/2000 Hajwanic  
 6,095,033 A 8/2000 Melton  
 6,202,542 B1 3/2001 Melton  
 6,231,226 B1 5/2001 Neidigh  
 D446,681 S 8/2001 Weibel  
 6,269,736 B1 8/2001 Melton  
 6,276,262 B1 8/2001 Chen  
 D450,106 S 11/2001 Herr  
 6,314,866 B1 11/2001 Melton  
 6,372,270 B1 4/2002 Denny  
 RE37,773 E 7/2002 Trombley  
 6,442,961 B1 9/2002 Rosenberg et al.  
 D473,092 S 4/2003 Heiberg et al.  
 6,578,726 B1 6/2003 Schaefer  
 D484,743 S 1/2004 Furlong  
 D490,266 S 5/2004 Imai  
 6,742,442 B1 6/2004 Su  
 6,752,287 B1 6/2004 Lin  
 6,758,363 B2 7/2004 Stokes  
 6,763,964 B1 7/2004 Hurlbut et al.  
 D495,458 S 8/2004 Baldinger et al.  
 6,871,914 B2 3/2005 Stewart, Jr.  
 D511,684 S 11/2005 Guyot  
 7,032,507 B2 4/2006 Cai  
 D524,599 S 7/2006 Bodum  
 D530,590 S 10/2006 Singtoroj et al.  
 7,219,600 B1 5/2007 Haven et al.  
 D560,951 S 2/2008 Appleton  
 D563,161 S 3/2008 Bodum

D569,324 S 5/2008 Gosnell et al.  
 D569,618 S 5/2008 Kirk  
 D571,145 S 6/2008 Rae  
 D579,717 S 11/2008 Pawson et al.  
 7,464,368 B2 12/2008 Kothari et al.  
 7,464,637 B1\* 12/2008 Lin ..... A47J 31/0636  
 99/317  
 D587,513 S 3/2009 Bodum  
 D587,514 S 3/2009 Bodum  
 D587,957 S 3/2009 Imai  
 D592,123 S 5/2009 Cady  
 D597,396 S 8/2009 Menzies  
 D598,234 S 8/2009 Bodum  
 D602,730 S 10/2009 Kino  
 D613,114 S 4/2010 Hewitt  
 7,779,751 B2 8/2010 Gilbert  
 D644,072 S 8/2011 McDonald et al.  
 7,992,487 B1 8/2011 Kahl  
 7,997,423 B2 8/2011 Goodman et al.  
 8,079,301 B2 12/2011 Birch  
 8,221,813 B2 7/2012 Boul  
 8,561,834 B2 10/2013 Ziegler  
 D694,579 S 12/2013 Khubani  
 D699,509 S 2/2014 El-Saden et al.  
 8,778,432 B2\* 7/2014 Lown ..... A23F 3/18  
 426/432  
 D717,102 S 11/2014 Taketani et al.  
 2003/0080048 A1 5/2003 Lin  
 2003/0221563 A1\* 12/2003 Lee ..... A47J 31/002  
 99/279  
 2004/0261631 A1 12/2004 Lee  
 2005/0284303 A1 12/2005 Zell et al.  
 2006/0185521 A1 8/2006 Publicover et al.  
 2007/0089614 A1 4/2007 Tremblay  
 2007/0101870 A1 5/2007 Liu et al.  
 2008/0173183 A1 7/2008 Chen  
 2008/0282900 A1 11/2008 Huang  
 2009/0178573 A1 7/2009 Pan  
 2010/0263549 A1 10/2010 Lee  
 2011/0056386 A1 3/2011 Taketani  
 2011/0162532 A1 7/2011 Gilbert  
 2011/0219956 A1 9/2011 Englert et al.  
 2011/0226133 A1 9/2011 Shen  
 2011/0265438 A1 11/2011 Ryan  
 2012/0225175 A1 9/2012 Lown

FOREIGN PATENT DOCUMENTS

EP 2294949 11/2014  
 JP 59-124273 7/1984  
 JP 63-088245 4/1988  
 JP 1-151768 10/1989  
 JP 8310531 11/1996  
 JP 11075693 3/1999  
 JP 11-253312 9/1999  
 JP 2011-6088 1/2011  
 WO WO 03/101263 12/2003

OTHER PUBLICATIONS

English Translation for CN 201398776 published Feb. 10, 2010.\*  
 International Search Report and Written Opinion on corresponding  
 PCT application (PCT/US2012/027695) from International Search-  
 ing Authority (KIPO) dated Oct. 19, 2012.

\* cited by examiner

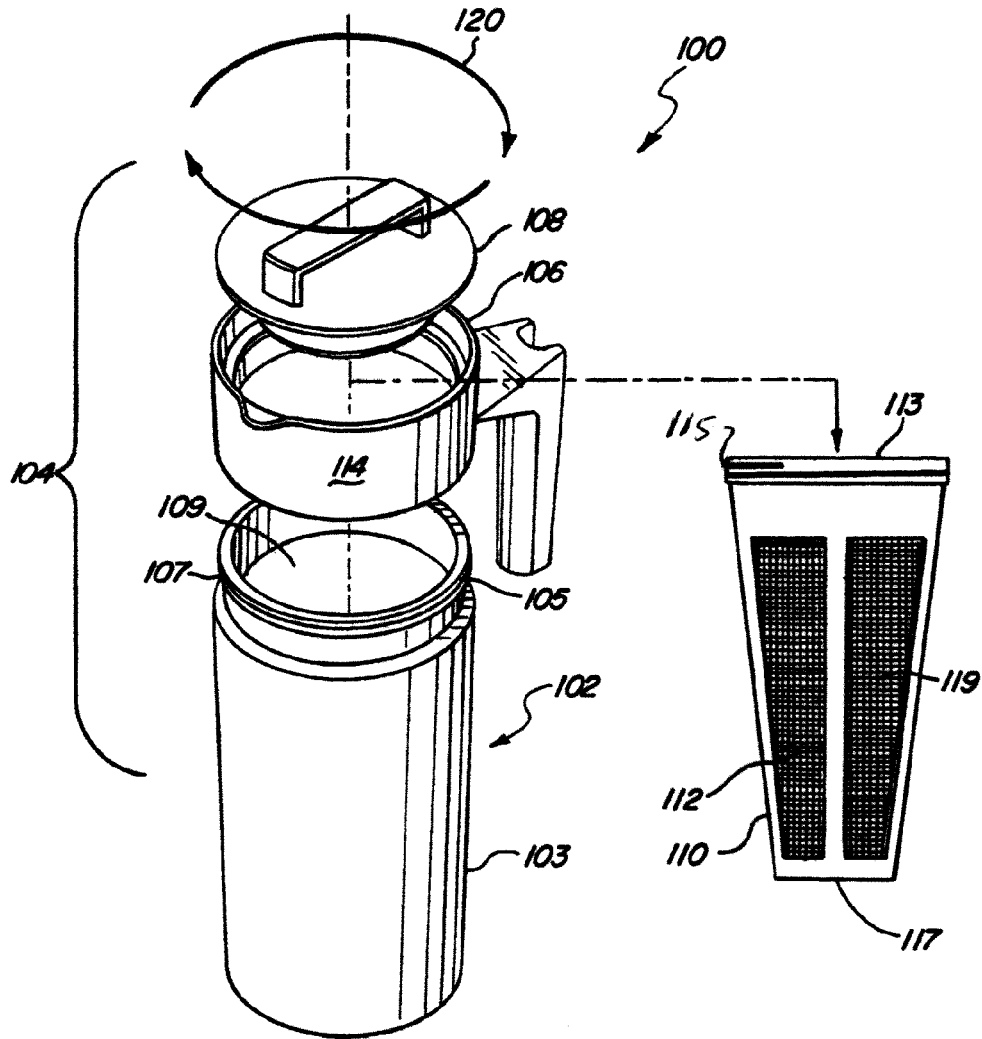
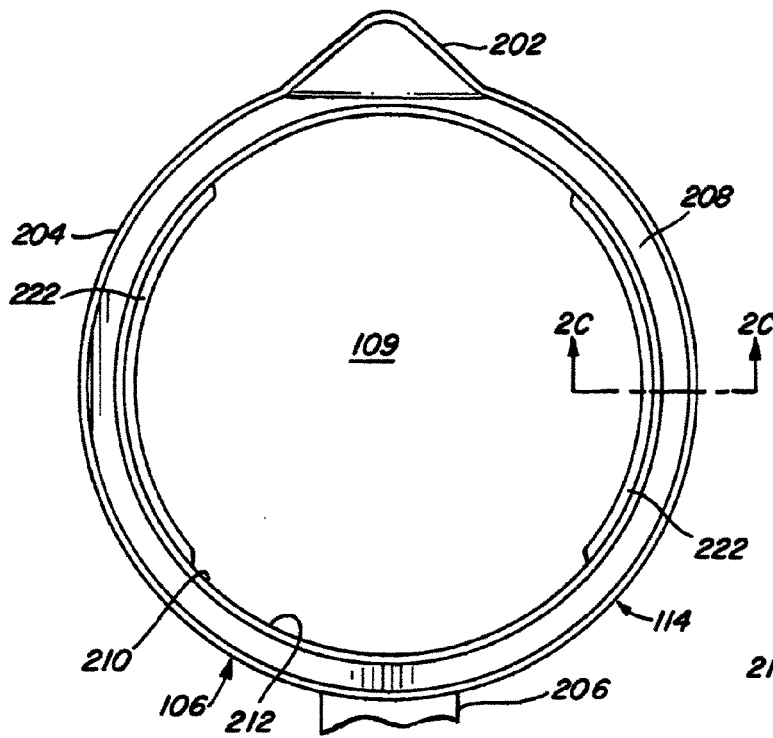
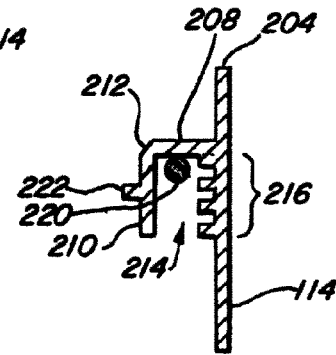

FIG. 1



**FIG. 2A**



**FIG. 2C**

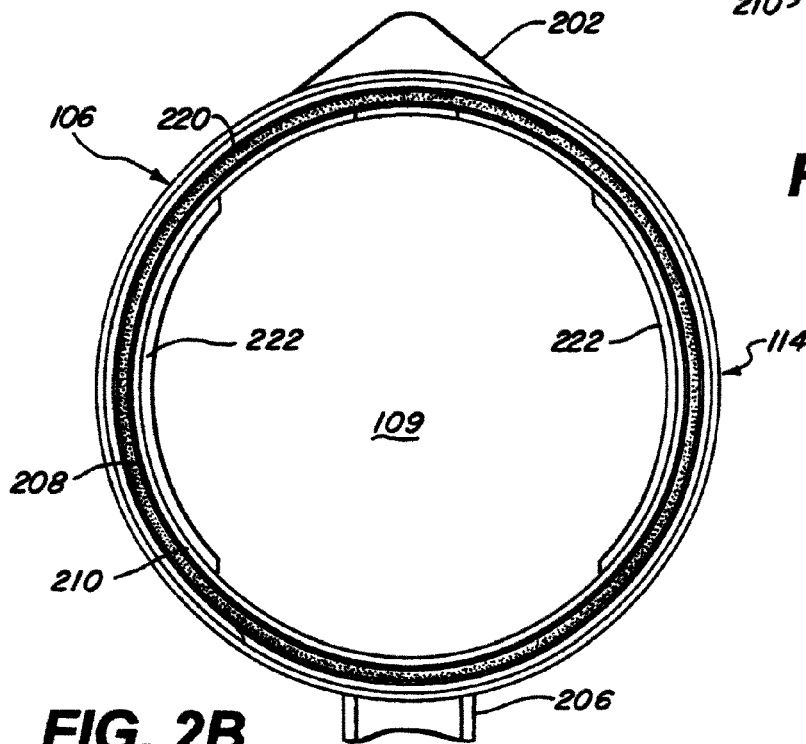

**FIG. 2B**

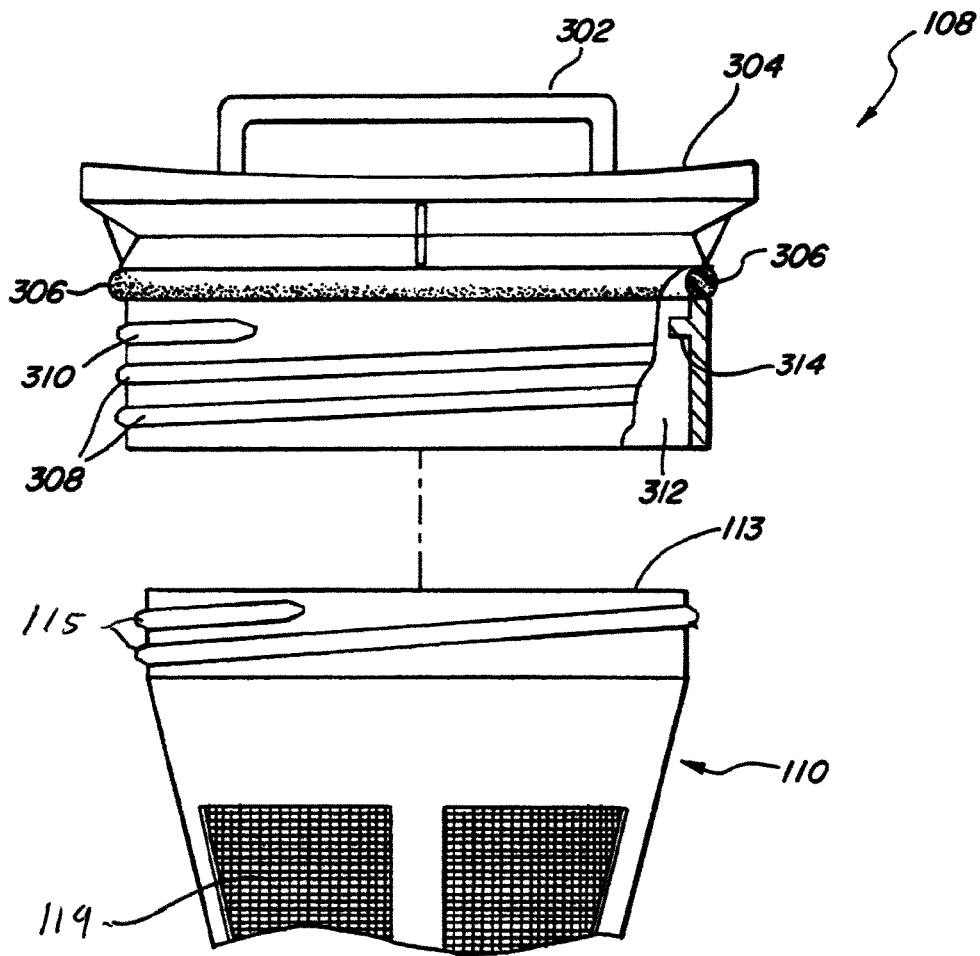

**FIG. 3**

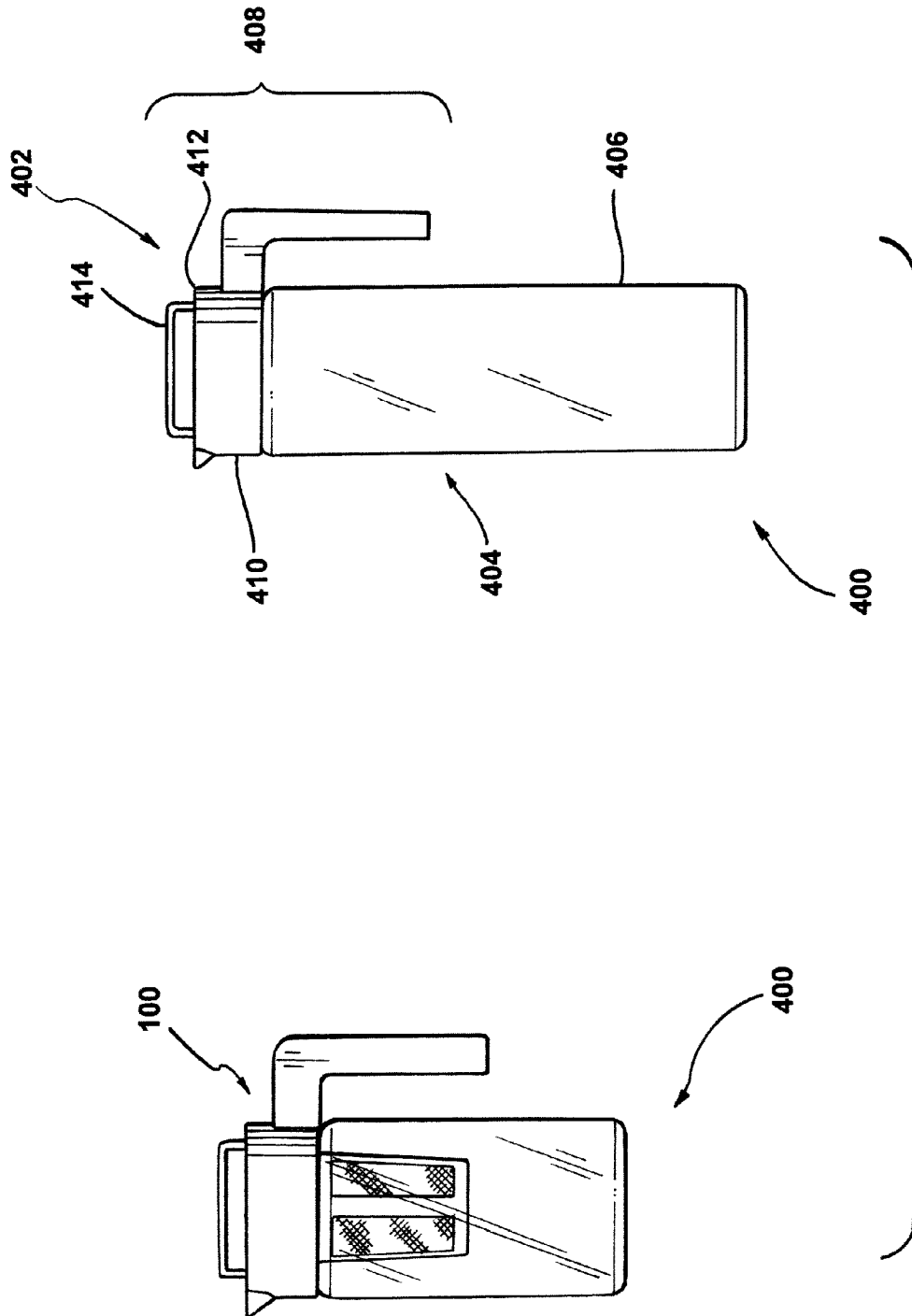

FIG. 4

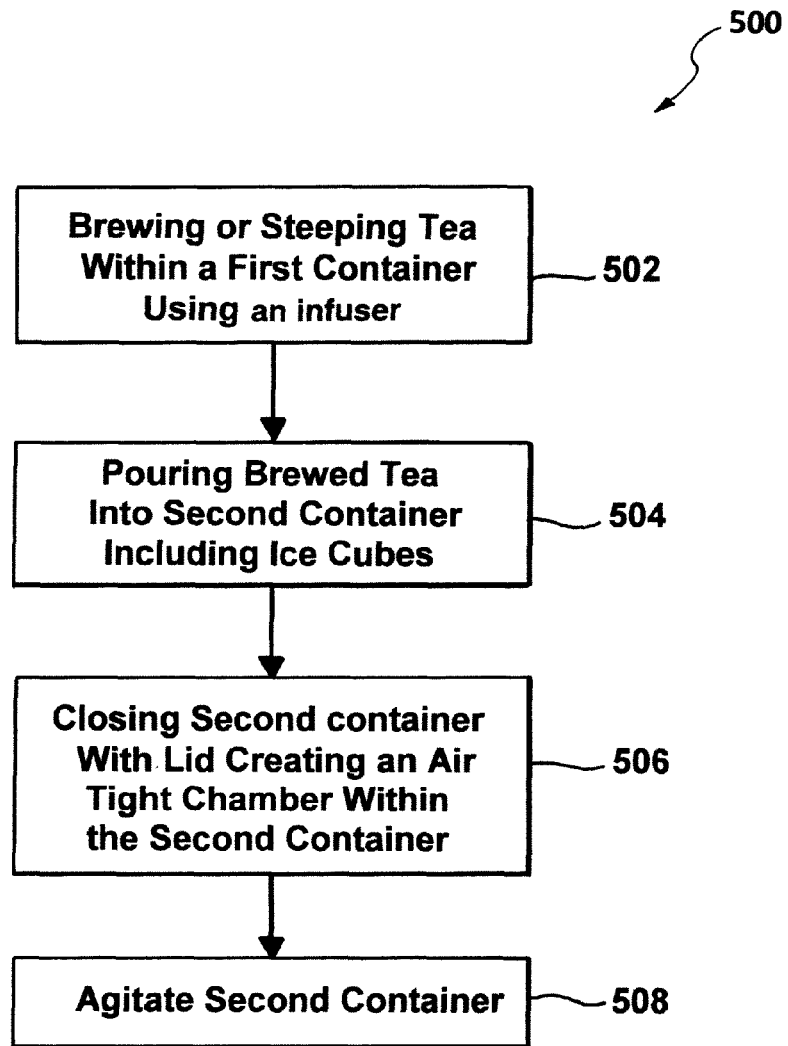

FIG. 5

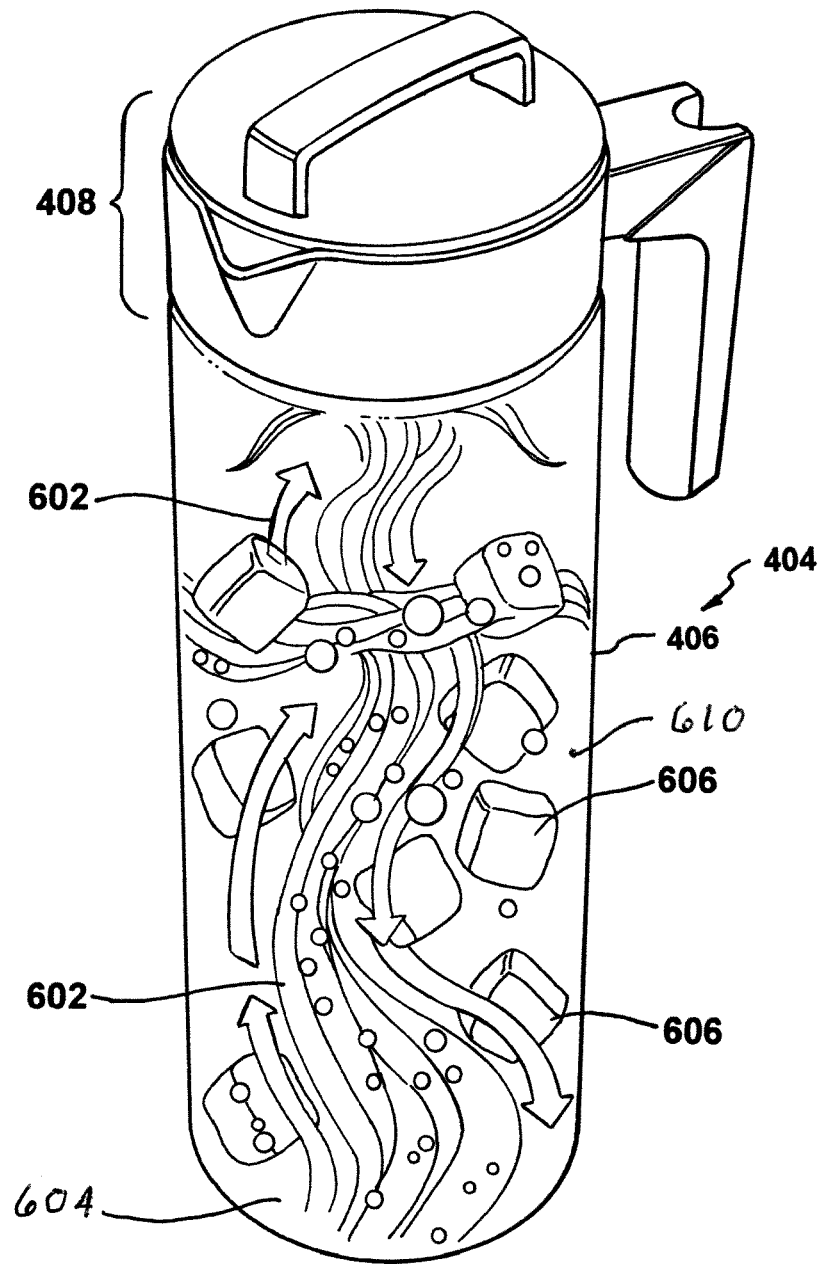

FIG. 6



1

**METHOD OF PREPARING ICED TEA**INCORPORATION BY REFERENCE TO ANY  
PRIORITY APPLICATIONS

This application is a continuation of U.S. application Ser. No. 13/041,117, filed Mar. 4, 2011, now U.S. Pat. No. 8,778,432 which is hereby incorporated herein by reference in its entirety and is to be considered a part of this specification. Any and all applications for which a foreign or domestic priority claim is identified in the Application Data Sheet as filed with the present application are hereby incorporated by reference under 37 CFR 1.57.

## BACKGROUND

## Field of the Invention

The disclosure relates to a method and associated apparatus for making a brewed beverage, such as tea, and for chilling the brewed beverage.

## Description of the Related Art

Tea and other steeped beverages are customarily prepared by placing tea leaves in a pot, over which near-boiling water is poured. Typically, it is known to provide screens or strainers, known as infusers, to confine the tea leaves during the brewing cycle.

In general, when making iced tea, the tea generally must be cooled to at least room temperature before adding ice to ensure that the ice does not melt to the extent that the tea is uncontrollably diluted. The preparation of iced tea thus may be a labor and time intensive process.

## SUMMARY OF THE INVENTION

In one aspect, a method for chilling tea is provided. The method includes brewing tea within a first container, the first container including an infuser; pouring the brewed tea into a second container containing a chilling medium (e.g., ice); and covering the second container with a first lid assembly that provides an air tight seal to the second container.

Advantageously, covering the second container with an airtight seal locks in the freshness and flavor of the beverage. The airtight seal retains and intensifies the tea aroma and flavor. The second container may be rocked or agitated so as to thoroughly infuse and chill the tea.

This brief summary has been provided so that the nature of this disclosure may be understood quickly. A more complete understanding of the disclosure can be obtained by reference to the following detailed description of the various embodiments thereof in connection with the attached drawings.

## BRIEF DESCRIPTION OF THE DRAWINGS

The foregoing features and other features of the present disclosure will now be described with reference to the drawings of illustrated embodiments. The illustrated embodiments are intended to illustrate, but not to limit the disclosure. The drawings include the following Figures:

FIG. 1 is an exploded perspective view of a container assembly in accordance with an embodiment;

FIGS. 2A and 2B are top and bottom views respectively of a lid ring component of a lid assembly in accordance with an embodiment;

FIG. 2C is a cross-sectional view taken along line 2C-2C of FIG. 2A, in accordance with an embodiment; and

2

FIG. 3 is an exploded view of a cover that includes a removable infuser in accordance with an embodiment;

FIG. 4 is side elevational view of beverage brewing and chilling system in accordance with an embodiment;

FIG. 5 is a method of brewing and chilling a beverage using the system of FIG. 4 in accordance with an embodiment; and

FIG. 6 is a perspective view of the second container of the system of FIG. 4, including a beverage and a chilling medium, in accordance with an embodiment.

## DETAILED DESCRIPTION

FIG. 1 is an exploded perspective view of a first or infuser container assembly **100** in accordance with an embodiment. The first container assembly **100** includes a brewing container, such as a pitcher, jug, pot or bottle **102** (hereinafter, “brewing pitcher **102**”) having a first lid assembly **104** that includes a lid ring **106**, a cover **108** and a brew basket or infuser **110**.

The brewing pitcher **102** includes a container body **103** that defines a volume used to hold or contain a substance which may be made to flow from the container, for example a liquid or a powder. Though not limited thereto, the container body **103** may have a generally circular, oval or rectangular cross-section that terminates at a continuous upper edge or rim **105**. The rim **105** defines an open top portion **109** of the brewing pitcher **102**. In some embodiments, the rim may have formed thereon container threads **107** for mounting and securing the brewing pitcher **102** to a lid, for example, reclosable lid or cover **108**.

Alternatively, the brewing pitcher may be designed such that the top rim **105** of the pitcher **102** may be force fit into a corresponding portion of the lid assembly **104** designed to receive the rim **105**.

In one embodiment, the infuser **110** includes a well **112** that extends from an upper rim **113** downwardly to a bottom wall **117**. The well **112** has side walls substantially provided by a porous filter medium **119** (which may be, for example, a metal, fabric, or polymeric mesh or screen), and is generally configured to contain tea leaves, herbal leaves, or other material from which a steeped beverage is brewed. Liquid disposed in the brewing pitcher **102** enters into the well **112** through the filter medium **119**. Specifically, hot water poured into the brewing pitcher **102** flows through the filter medium **119** and contacts the material in the well **112** to create the brewed beverage, which then flows out of the well **112** back into the brewing pitcher **102**.

FIGS. 2A and 2B are top and bottom views, respectively, of the lid ring **106** of the lid assembly **104** in accordance with an embodiment. As shown in FIG. 2A, the lid ring **106** includes a generally cylindrical body portion that provides a side wall **114** (FIG. 1) defining a tubular opening. The lid ring **106** provides the primary coupling interface between the brewing pitcher **102** and the lid assembly **104**. As shown in FIG. 2A, the lid ring **106** includes a spout **202** formed on a rim **204** on the circumference of the lid ring **106**. The spout **202** is diametrically opposed from a handle **206** formed on an external surface of side wall **114**.

Referring now to FIGS. 1, 2A, 2B and 2C, the lid ring **106** includes a lip portion **208** that provides a seat for the cover **108** when the cover is secured to the lid ring **106**. As shown in FIG. 2C, a flange portion **210** extends perpendicularly down from an internal edge **212** of the lip portion **208**. The lip portion **208** and flange portion **210** create a seating area **214** that is formed and configured to receive the rim **105** of the brewing pitcher **102** between the flange portion **210** and

an internal surface of the side wall 114. In one embodiment, internal threads 216 may be formed on side wall 114 in the seating area 214 to provide for a threadable engagement with the threads 107 formed on the rim 105 of the brewing pitcher 102 to removably secure the lid ring 106 to the brewing pitcher 102. In one embodiment, a gasket or O-ring 220 may be positioned in the seating area 214 to ensure that the lid ring 106 is sealingly mated to the brewing pitcher 102.

Inward of the seating area 214, the flange portion 210 provides a surface upon which ring threads 222 are formed and positioned to provide a threadable engagement with the cover 108 described below.

FIG. 3 is an exploded view of the cover 108 that includes a removable infuser 110 in accordance with an embodiment. In one embodiment, the cover 108 includes a cover handle 302 on a cover top surface 304. In one embodiment, the cover handle 302 resembles a rectangular loop formed on an external surface of the cover. Adjacent and below the cover top surface 304 is a groove configured to hold an O-ring type gasket 306. The O-ring gasket 306 provides a positive seal between the cover 108 and the lid ring 106 when the cover 108 is coupled to the lid ring 106.

The cover 108 includes a cover skirt 310, which extends down away from the top surface 304 on the opposite side from cover handle 302. As shown in the cut-away section in FIG. 3, the cover skirt 310 defines a hollow space 312 configured to receive the infuser 110 as described below.

An external surface of the cover skirt 310 includes a set of external cover threads 308 formed and configured to threadably engage with the ring threads 222 to provide the threadable engagement with cover 108.

Within the hollow space 312 a set of internal cover threads 314 are formed generally adjacent the cover top surface 304 on an internal surface of the cover skirt 310. The internal cover threads 314 provide a means for the cover 108 to engage with corresponding infuser threads 115 provided at the upper rim 113 of the infuser 110. In this manner, the infuser 110 may be removably secured to the cover 108.

Referring now to FIG. 4, the first or infuser container assembly 100 described above may be used as a component of a tea maker system 400 in accordance with an embodiment of the present invention. In the tea maker system 400, the first or infuser container assembly 100 is combined with a second or chilling container assembly 402 that provides an ability to “chill” the beverage brewed or steeped in the first container assembly 100.

The second container assembly 402 has the same general characteristics as the first container assembly 100, except that it does not include an infuser. For example, the second container assembly 402 may include a chilling pitcher 404 having a body 406 that defines a volume used to hold or contain a substance which may be made to flow from the container body. Though not limited thereto, the container body 406 may have a generally circular, oval or rectangular cross-section that terminates at a continuous upper edge or rim that defines an open top end of the chilling pitcher 404. In some embodiments, the rim may have formed thereon container threads for removably mounting and securing a second lid assembly 408 to the top end of the chilling pitcher 404. The second lid assembly 408 may advantageously be essentially the same as the first lid assembly 108, except that it may omit the above-described structure for removably attaching an infuser. Thus, the second lid assembly 408 includes a second lid ring 410 and a second reclosable lid 412 having a second lid handle 414. The second lid ring 410 may advantageously be essentially identical to the first lid

ring 106 described above and illustrated in FIGS. 2A, 2B, and 2C. Therefore the above description of the first lid ring 106 applies to the second lid ring 410 and does not need to be repeated.

In this embodiment, the chilling pitcher 404 is shown having a height and diameter that is different from those of the brewing pitcher 102. Alternatively, the chilling pitcher 404 and the brewing pitcher 102 may have substantially the same dimensions. It should be understood that the chilling pitcher 404 may still maintain the capability to include an infuser, as described above, such that its use with the first or infuser container assembly 100 is interchangeable within the tea maker system 400. In one embodiment, in the tea maker system 400, the first container assembly 100 may provide the ability to brew the tea using the infuser 110, while the second container assembly 402, without the infuser, provides a receptacle in which to chill the tea in the manner described below.

Reference is now made to FIGS. 1-5, where FIG. 5 is a flow chart of a method 500 for preparing and chilling a steeped beverage (e.g., tea) in accordance with an embodiment of the present disclosure.

In operation, a user may assemble the lid assembly 104 of the first container assembly 100 in any desired order. The embodiment now described provides one example for the assembly of the lid assembly 104.

First, the brewing pitcher 102 may be fastened to the lid ring 106 by threading the threads 216 of the lid ring 106 into threads 105 of the brewing pitcher 102.

Next, the infuser 110 is filled with an appropriate amount of tea leaves (not shown) or other herbal material from which the beverage is to be made. (For the sake of simplicity, reference in the following description to “tea leaves” will be understood to include any herbal or organic material from which a beverage may be brewed or steeped.) The infuser 110 is then attached to the cover 108 by threading the infuser 110 onto the internal cover threads 314 in the hollow space 312. The well 112 then extends downwardly from the center of the cover 108.

The combined cover 108 and infuser 110 may be inserted into the brewing pitcher 102 through the open top portion 109 having the lid ring 106 already attached. Generally, when the infuser 110 is inserted into the brewing pitcher 102 filled with liquid, the bottom of the well 112 is immersed below the surface of the liquid. The level of immersion is dependent on the predetermined length of the infuser well and the depth of the liquid. The porous filter medium 119 of the well 112 allows the liquid to circulate through the well 112 and contact any contents (e.g., tea leaves) therein.

Once the infuser 110 containing the tea leaves is positioned within the brewing pitcher 102, hot water from any hot water source is poured into the brewing pitcher 102 to brew or steep the concentrated tea (FIG. 5, step 502).

In one embodiment, the cover 108 may be attached and secured to the lid ring 106 by threading the external cover threads 308 into the ring threads 222. Advantageously, as the cover 108 with the infuser 110 attached is being threaded, the cover and infuser are made to rotate, for example, as represented by arrows 120 in FIG. 1. The rotation may be either clockwise or counter-clockwise depending on whether the cover is being opened or closed. The rotation causes the infuser 110 to rotate while being immersed in the liquid creating an agitation or mixing effect between the contents in the well 112 and the liquid. In this manner rotating the infuser 110 causes liquid to enter and exit the well 112 at a faster rate than when the infuser is not being rotated, which may facilitate or speed-up the steeping or brewing process.

5

When the cover **108** is less than completely threaded into lid ring **106**, the cover is not in a sealed relationship with the lid ring. Thus, liquid from brewing pitcher **102** may be poured out via the spout **202**. When the cover **108** is threaded completely onto the lid ring **106**, the O-ring **306** is seated onto the lip portion **208**, such that no fluid may be poured out from the brewing pitcher **102**.

In one example, when a user determines that a steeped beverage has reached a desired strength, the user may remove the cover **108** from the lid ring **106** and thus remove the infuser **110** from the liquid. The user may then remove the infuser **110** from the cover **108**. The user may then return the cover **108** to the lid assembly **104** to continue acting as a cover for the beverage in the brewing pitcher **102**.

The container body **406** of the chilling pitcher **404** is configured to be partially filled with a chilling medium (typically ice, in the form of ice cubes, crushed ice, shaved ice, or the like), which allows the container body **406** to be used to convert the freshly brewed tea to iced tea. In step **504** (FIG. **5**), the freshly brewed tea is poured from the brewing pitcher **102** into the container body **406** of the chilling pitcher **404**, which contains the ice. The brewed and concentrated tea may be then mixed with additional water. That is, the container body **406** may be topped off with water.

Next, in step **506**, as shown in FIGS. **5** and **6**, the second lid assembly **408** is fastened onto the container body **406** of the chilling pitcher **404**. The second lid ring **410** of the second lid assembly **408** engages the rim around the open top end of the chilling pitcher **404** so as to create an airtight seal therewith, thereby forming an airtight chamber **610** within the chilling pitcher. This airtight seal is advantageously provided by a gasket or O-ring, such as the gasket **220** shown in FIGS. **2B** and **2C**, keeping in mind that these figures apply to the second lid ring **410** as well as to the first lid ring **106**, as noted above. The airtight seal causes the airtight chamber **610** to trap any water vapor **602** created by the mixture of hot, freshly-brewed tea **604** and ice **606** in the container **406** of the chilling pitcher **404**. The vapor created in the airtight chamber **610** is then forced back into the tea **604**. The airtight chamber **610** created by sealing the container body **406** should help in maintaining optimum flavor within the tea **604** without causing the ice **606** to melt prematurely.

In step **508** (FIG. **5**), the chilling pitcher **404** may be agitated as needed.

Although the present disclosure has been described with reference to specific embodiments, these embodiments are illustrative only and not limiting. Many other applications and embodiments of the present disclosure will be apparent in light of this disclosure and the following claims.

What is claimed is:

**1.** A method of preparing iced tea, the method comprising: combining tea with a chilling medium in a container comprising a body having an open top; sealing the combined tea and chilling medium in an air tight manner within the container by securing a cover to a lid ring to enclose the container and to lock in vapor created in the enclosed container, said lid ring attached to the body of the container; agitating the combined tea and chilling medium while sealed in the air tight manner inside the container to cool and dilute the tea and to prepare iced tea; removing an infuser having external threads from internal threads on the cover prior to combining the tea with the chilling medium; and

6

wherein the infuser having a porous filter medium for steeping tea leaves is located inside the body and enclosed inside the container by the cover secured to the lid ring.

**2.** The method of claim **1**, wherein the chilling medium comprises ice cubes and the lid ring comprises a handle extending downwardly from a sidewall.

**3.** The method of claim **1**, wherein the container is a second container and wherein combining the tea with the chilling medium further comprises pouring the tea from a first container comprising a lid ring having a spout into the second container containing the chilling medium.

**4.** The method of claim **3**, wherein the tea is produced by placing tea leaves in the infuser.

**5.** The method of claim **1**, further comprising opening the cover from the lid ring to break the air tight seal and pouring a portion of the iced tea from the container.

**6.** A method of preparing iced tea, the method comprising: combining tea that is still hot with a chilling medium comprising ice cubes in a container comprising a body with an open top, wherein a lid ring is attached to the body of the container and comprises a handle and a spout;

sealing the combined tea that is still hot and the chilling medium in an air tight manner inside the container by attaching a cover to the lid ring to lock in vapor created in the body of the container, wherein said cover comprises a top surface comprising a cover handle located on the top surface; and

agitating the combined still hot tea and the chilling medium while sealed in the air tight manner inside the container to cool and dilute the tea and to prepare iced tea.

**7.** The method of claim **6**, further comprising an infuser sealed inside the body of the container by the cover attaching to the lid ring.

**8.** The method of claim **6**, wherein the container is a second container and wherein combining the still hot tea with the chilling medium further comprises pouring the still hot tea from a first container into the second container containing the chilling medium.

**9.** The method of claim **6**, wherein the lid ring comprises internal threads for threaded engagement with external threads on the body of the container.

**10.** The method of claim **6**, wherein an infuser with tea leaves located in a cavity of the infuser is threaded to internal threads on the cover.

**11.** The method of claim **6**, wherein the cover has internal threads and external threads located on a cover skirt.

**12.** The method of claim **6**, wherein the handle and the spout are equally spaced along a sidewall of the lid ring.

**13.** The method of claim **6**, further comprising an O-ring between the lid ring and the container.

**14.** The method of claim **13**, wherein the container comprises external threads for threaded engagement with the lid ring.

**15.** The method of claim **8**, wherein the second container and the first container are of different sizes.

**16.** The method of claim **6**, further comprising an infuser with external threads for engaging internal threads on the lid ring and removing the infuser prior to combining the tea that is still hot with the chilling medium.

**17.** The method of claim **16**, wherein the infuser contains tea leaves.

**18.** The method of claim **1**, wherein the cover comprises a cover top surface and wherein a cover handle is located on the cover top surface.

7

19. The method of claim 18, wherein the cover has external threads for threaded engagement with the lid ring and internal threads for threaded engagement with the infuser.

20. A method of preparing iced tea, the method comprising: 5

combining tea with a chilling medium in a container comprising a body having an open top;

sealing the combined tea and chilling medium in an air tight manner within the container by securing a cover to a lid ring to enclose the container and to lock in vapor created in the enclosed container, said lid ring attached to the body of the container; 10

agitating the combined tea and chilling medium while sealed in the air tight manner inside the container to cool and dilute the tea and to prepare iced tea; 15

removing an infuser having tea leaves located therein from the cover; and

wherein the infuser having a porous filter medium for steeping tea leaves is located inside the body and enclosed inside the container by the cover secured to the lid ring. 20

21. A method of preparing iced tea, the method comprising:

8

removing a cover and an infuser from a lid ring attached to an open top of a body of a container; wherein a lid ring comprises a handle and a spout and the cover comprises a cover handle attached to a cover top surface;

combining tea that is still hot with a chilling medium comprising ice cubes in the body of the container;

sealing the combined tea that is still hot and the chilling medium in an air tight manner inside the container by attaching the cover to the lid ring to lock in vapor created in the body of the container; and

agitating the combined still hot tea and the chilling medium while sealed in the air tight manner inside the container to cool and dilute the tea and to prepare iced tea.

22. The method of claim 21, wherein the cover is threadedly engaged to the lid ring and the lid ring is threadedly engaged to the body of the container.

23. The method of claim 22, wherein the infuser is located inside the body below the cover.

24. The method of claim 23, wherein the infuser is threadedly engaged to the cover.

\* \* \* \* \*