



US009622283B2

(12) **United States Patent**
Lee et al.

(10) **Patent No.:** US 9,622,283 B2
(45) **Date of Patent:** Apr. 11, 2017

(54) **METHOD OF SUPPORTING SIGNAL TRANSMISSION AND RECEPTION USING AT LEAST TWO RADIO ACCESS TECHNOLOGIES AND APPARATUS THEREFOR**

H04W 48/14 (2013.01); *H04W 72/048* (2013.01); *H04W 72/0446* (2013.01); *H04W 76/064* (2013.01); *H04W 36/08* (2013.01); *H04W 76/026* (2013.01); *H04W 88/06* (2013.01)

(71) Applicant: **LG ELECTRONICS INC.**, Seoul (KR)

(58) **Field of Classification Search**
CPC ... H04W 36/08; H04W 36/28; H04W 76/064; H04W 88/06; H04W 48/14
USPC 455/404.1, 426.1, 435.1; 370/332, 342, 370/442
See application file for complete search history.

(72) Inventors: **Eunjong Lee**, Anyang-si (KR);
Heejeong Cho, Anyang-si (KR);
Jaehoon Chung, Anyang-si (KR)

(73) Assignee: **LG Electronics Inc.**, Seoul (KR)

(56) **References Cited**

(*) Notice: Subject to any disclaimer, the term of this patent is extended or adjusted under 35 U.S.C. 154(b) by 0 days.

U.S. PATENT DOCUMENTS

9,313,694 B2* 4/2016 Lee H04W 36/0005
2012/0063414 A1* 3/2012 Ramachandran . H04W 36/0022
370/331

(21) Appl. No.: **15/074,795**

FOREIGN PATENT DOCUMENTS

(22) Filed: **Mar. 18, 2016**

KR 10-2007-0009333 A 1/2007
KR 10-2011-0001971 A 1/2011

(65) **Prior Publication Data**

US 2016/0212788 A1 Jul. 21, 2016

(Continued)

Related U.S. Application Data

Primary Examiner — Sam Bhattacharya

(63) Continuation of application No. 14/417,026, filed as application No. PCT/KR2013/006745 on Jul. 26, 2013, now Pat. No. 9,313,694.

(74) *Attorney, Agent, or Firm* — Dentons US LLP

(Continued)

(57) **ABSTRACT**

(51) **Int. Cl.**

H04W 36/08 (2009.01)
H04W 76/02 (2009.01)
H04W 36/00 (2009.01)
H04W 36/28 (2009.01)
H04W 76/06 (2009.01)

A method of supporting communication using two or more heterogeneous radio access technologies (RAT) comprises: receiving a setup message providing instructions for access to a second base station in a second communication network supporting the second RAT from a first base station in a first communication network supporting a first RAT; and attempting to access the second base station. At this time, when the terminal successfully accesses the second base station, specific traffic type data are transmitted and received through the second base station, and data other than the specific traffic type can be transmitted and received through the first base station.

(Continued)

(52) **U.S. Cl.**

CPC *H04W 76/025* (2013.01); *H04W 28/0215* (2013.01); *H04W 36/005* (2013.01); *H04W 36/0005* (2013.01); *H04W 36/28* (2013.01);

12 Claims, 14 Drawing Sheets

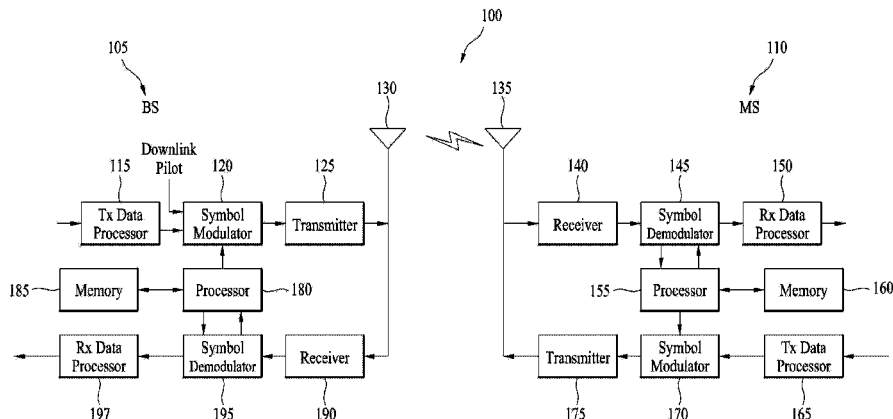

Related U.S. Application Data

(60) Provisional application No. 61/676,312, filed on Jul. 26, 2012, provisional application No. 61/692,241, filed on Aug. 23, 2012, provisional application No. 61/693,759, filed on Aug. 27, 2012, provisional application No. 61/699,263, filed on Sep. 10, 2012, provisional application No. 61/809,423, filed on Apr. 8, 2013.

(51) **Int. Cl.**

H04W 28/02 (2009.01)
H04W 48/14 (2009.01)
H04W 72/04 (2009.01)
H04W 88/06 (2009.01)

(56) **References Cited**

FOREIGN PATENT DOCUMENTS

KR	10-2011-0058907	A	6/2011
WO	2011/120577	A1	10/2011
WO	2012/002771	A2	1/2012
WO	2012/033774	A2	3/2012
WO	2012-034093	A1	3/2012
WO	2012-037281	A1	3/2012
WO	2012/050387	A2	4/2012

* cited by examiner

FIG. 1

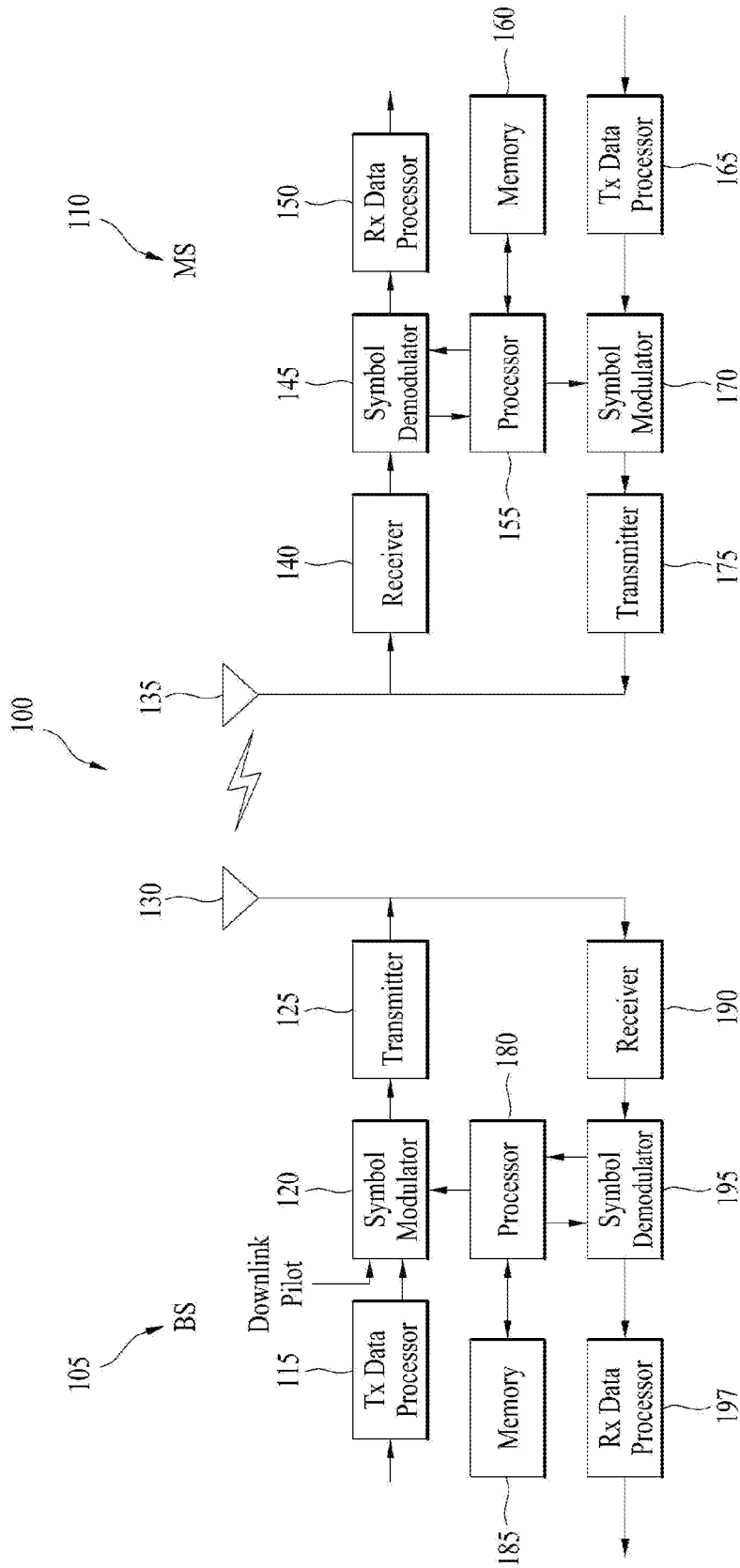

FIG. 2

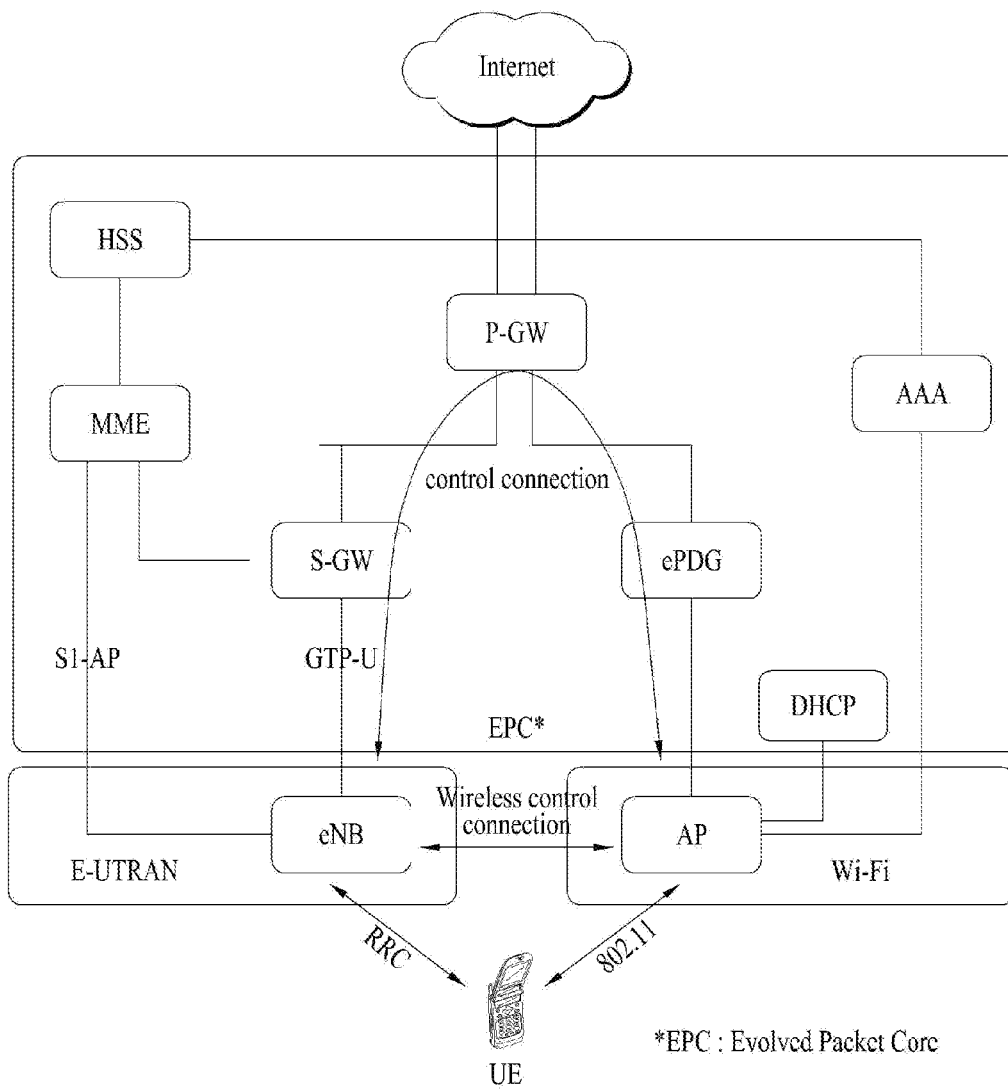

FIG. 3a

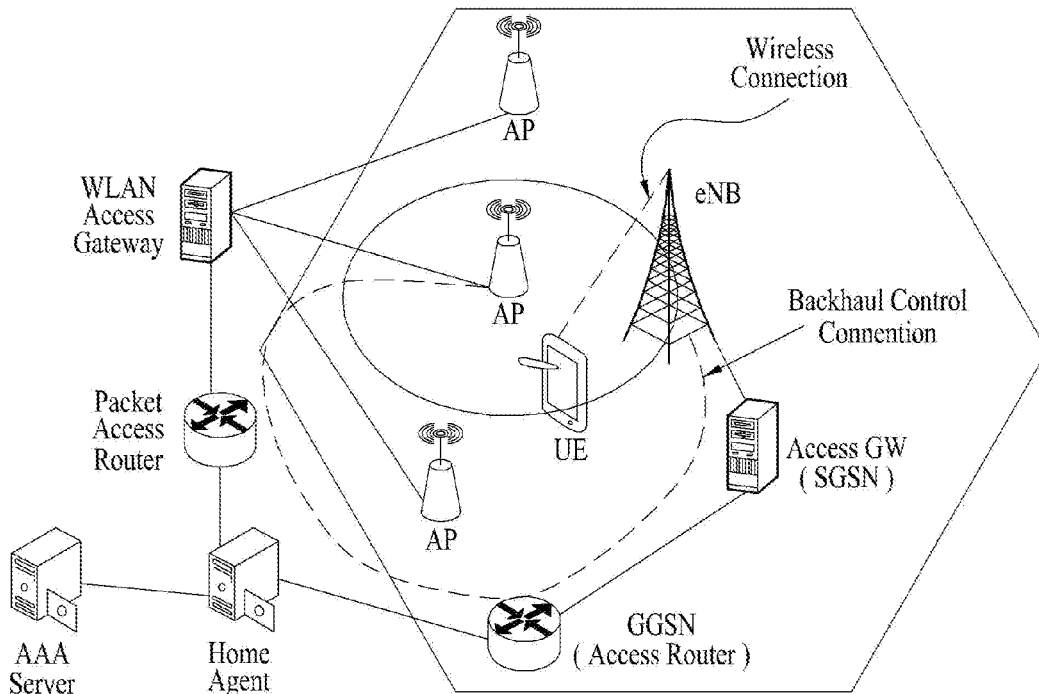

FIG. 3b

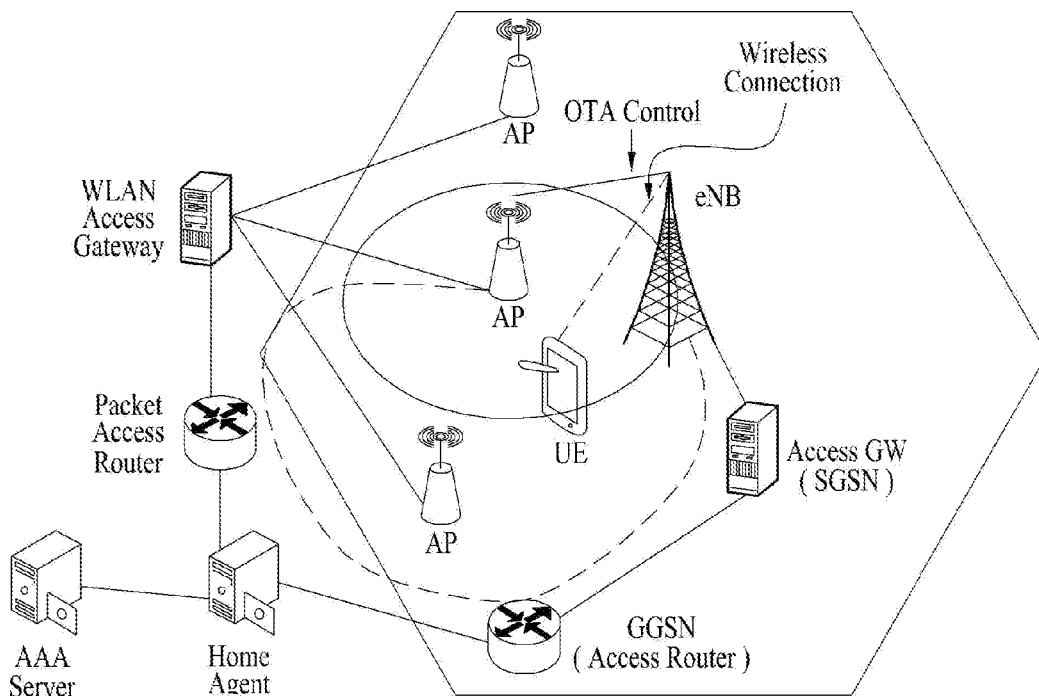

FIG. 4

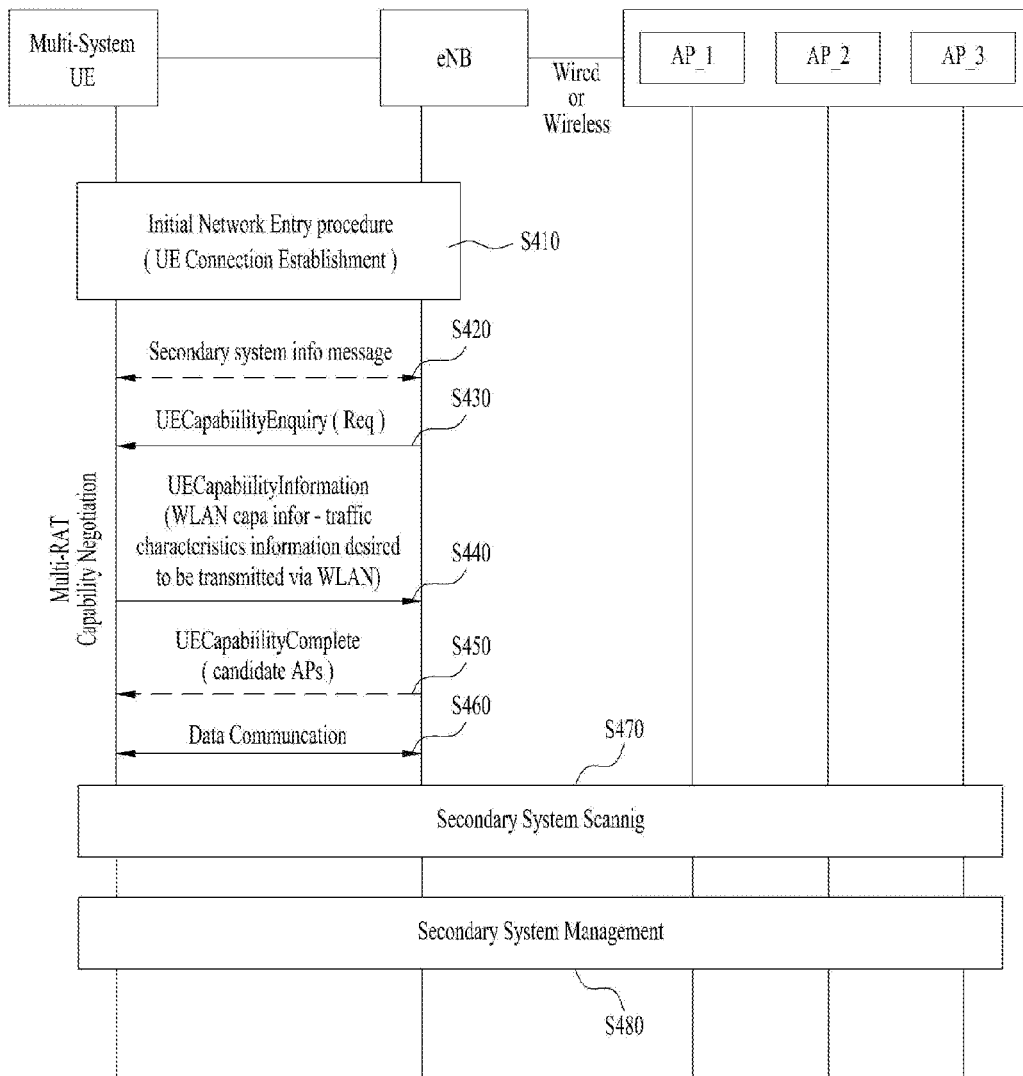

FIG. 5

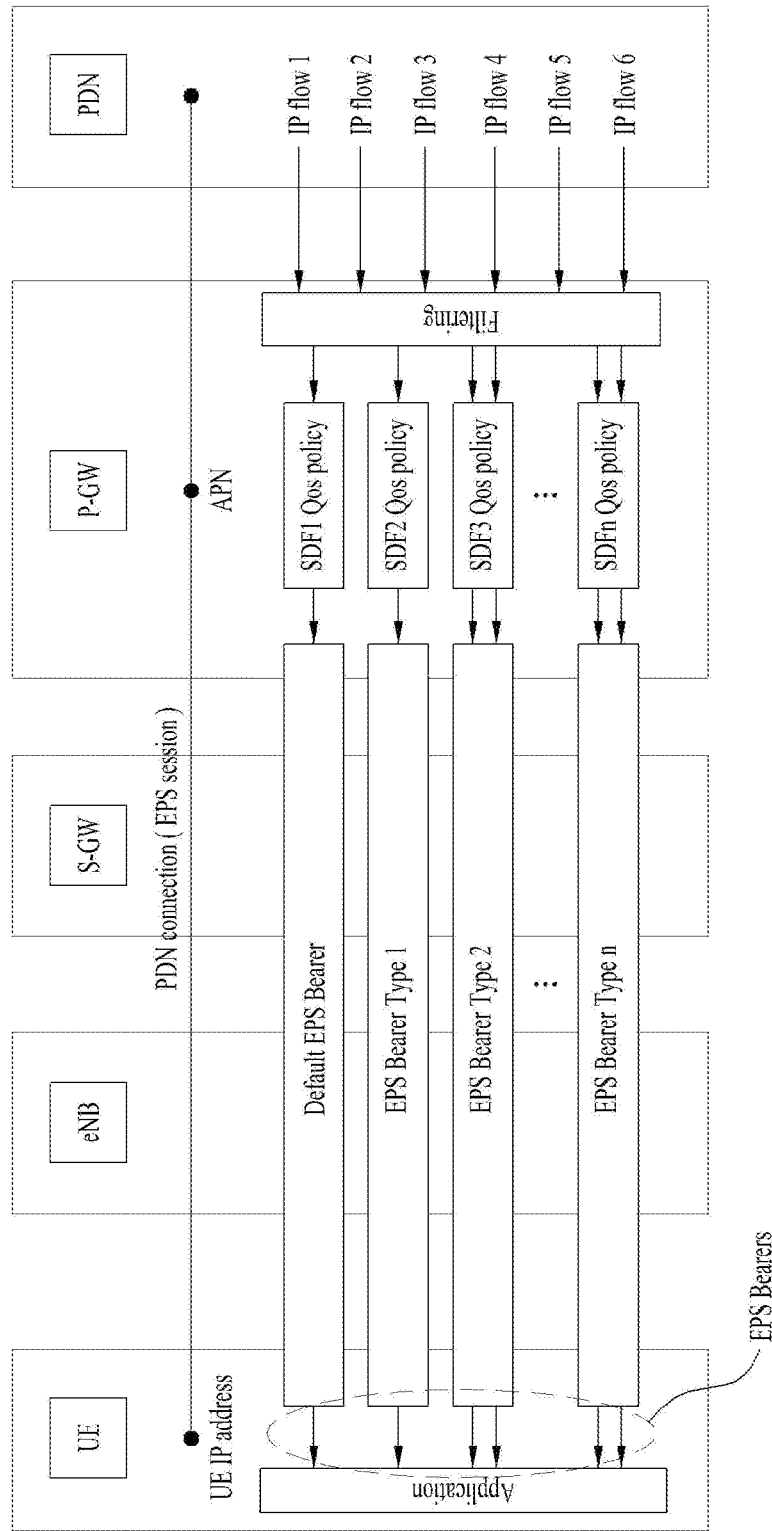

FIG. 6

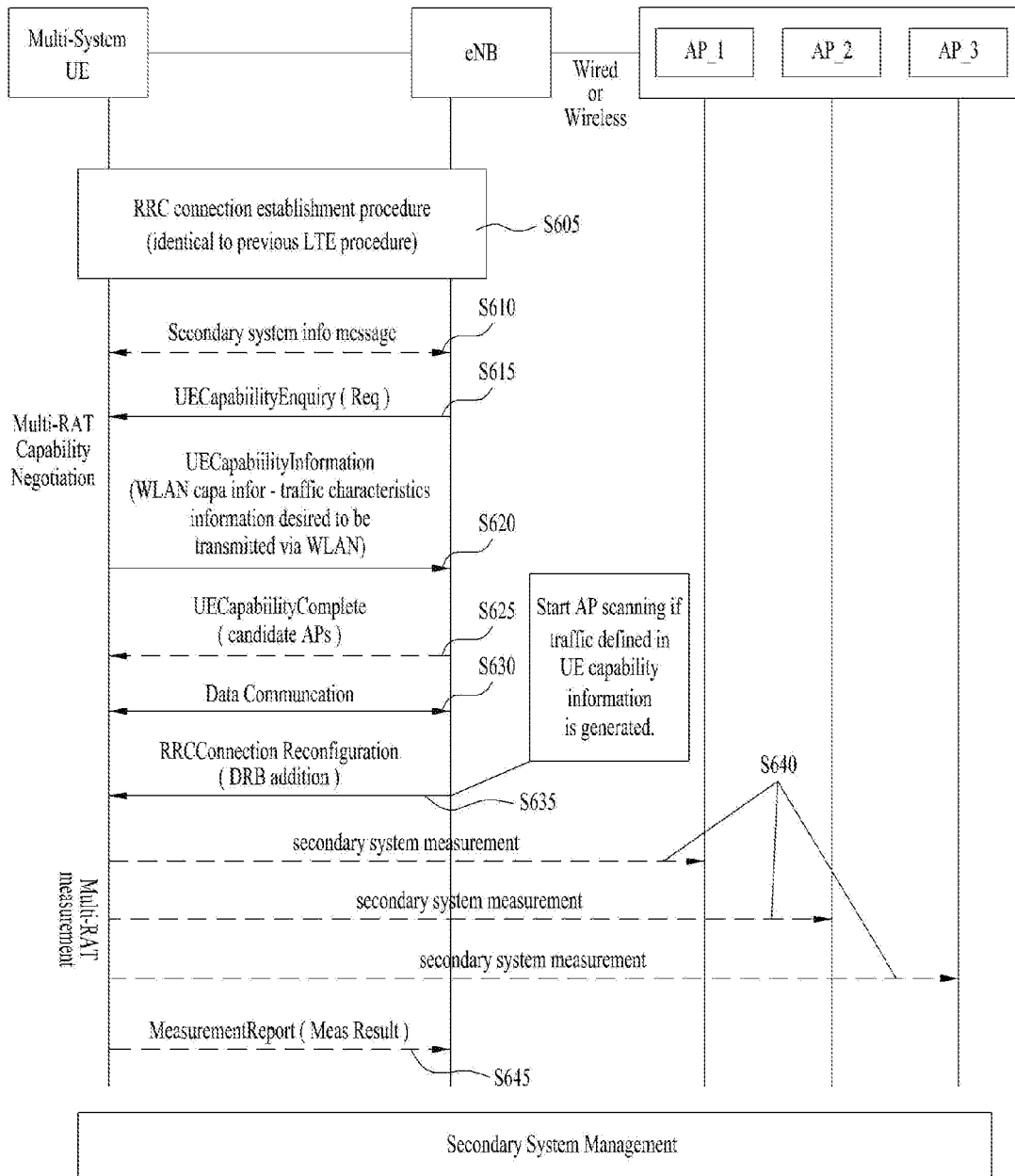

FIG. 7

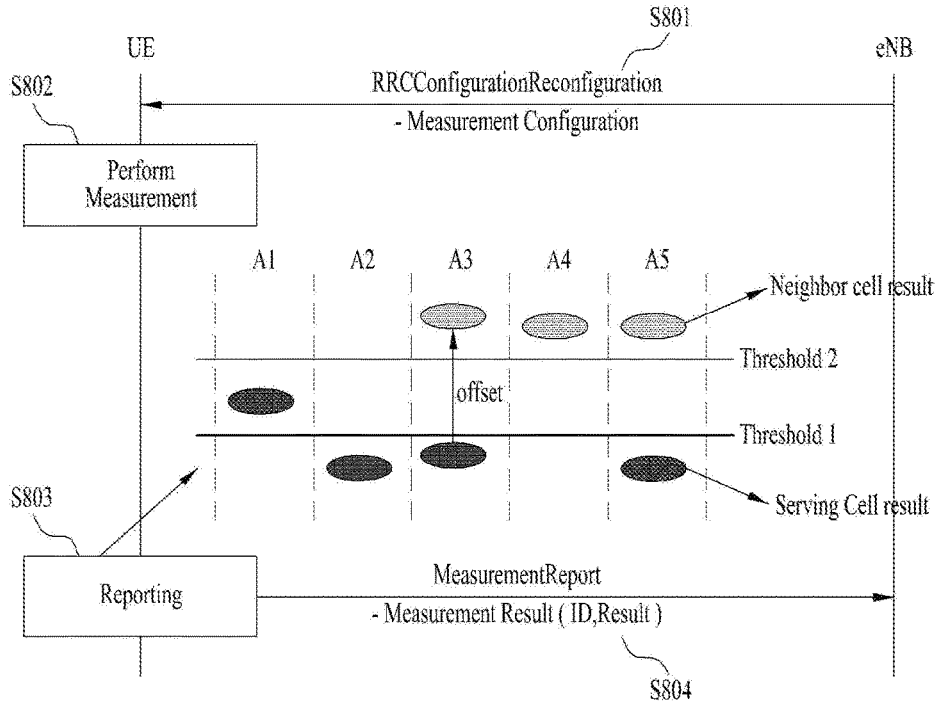

FIG. 8

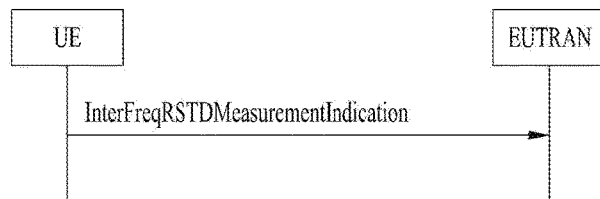
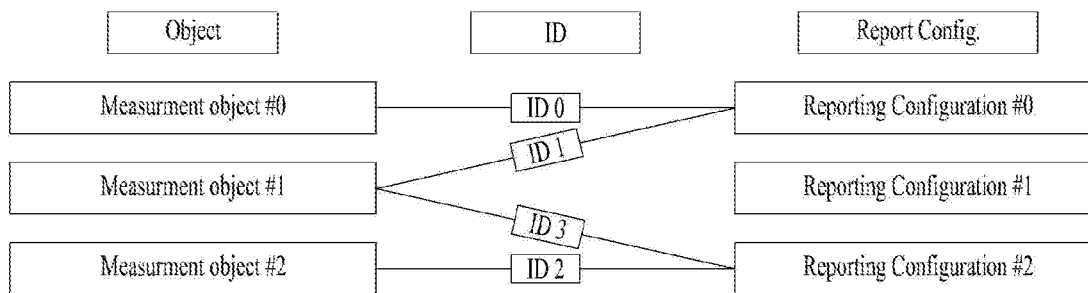

FIG. 9



- * A single E-UTRA carrier frequency
- * A set of cells on a single UTRA carrier frequency
- * A set of GERAN carrier frequencies
- * A set of cells on a single (HRPD or 1xRTT) carrier frequency
- * A set of E-UTRA carrier frequency
- * A set of E-UTRA data bearers (or flows) on a single E-UTRA carrier freq.
- * A set of WLAN data bearers (or flows) on a single WLAN carrier freq.

- * Reporting criteria
- * Reporting format (periodic or event-triggered/RSRP or..)

FIG. 10

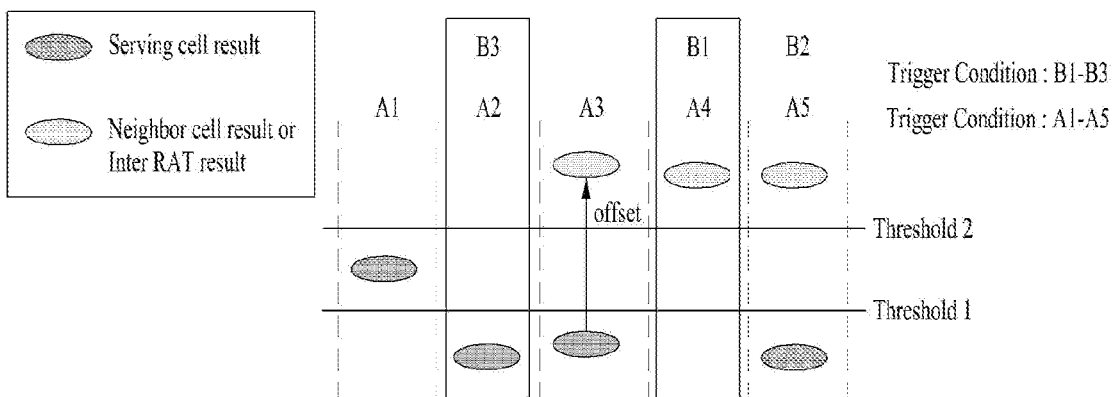

FIG. 11

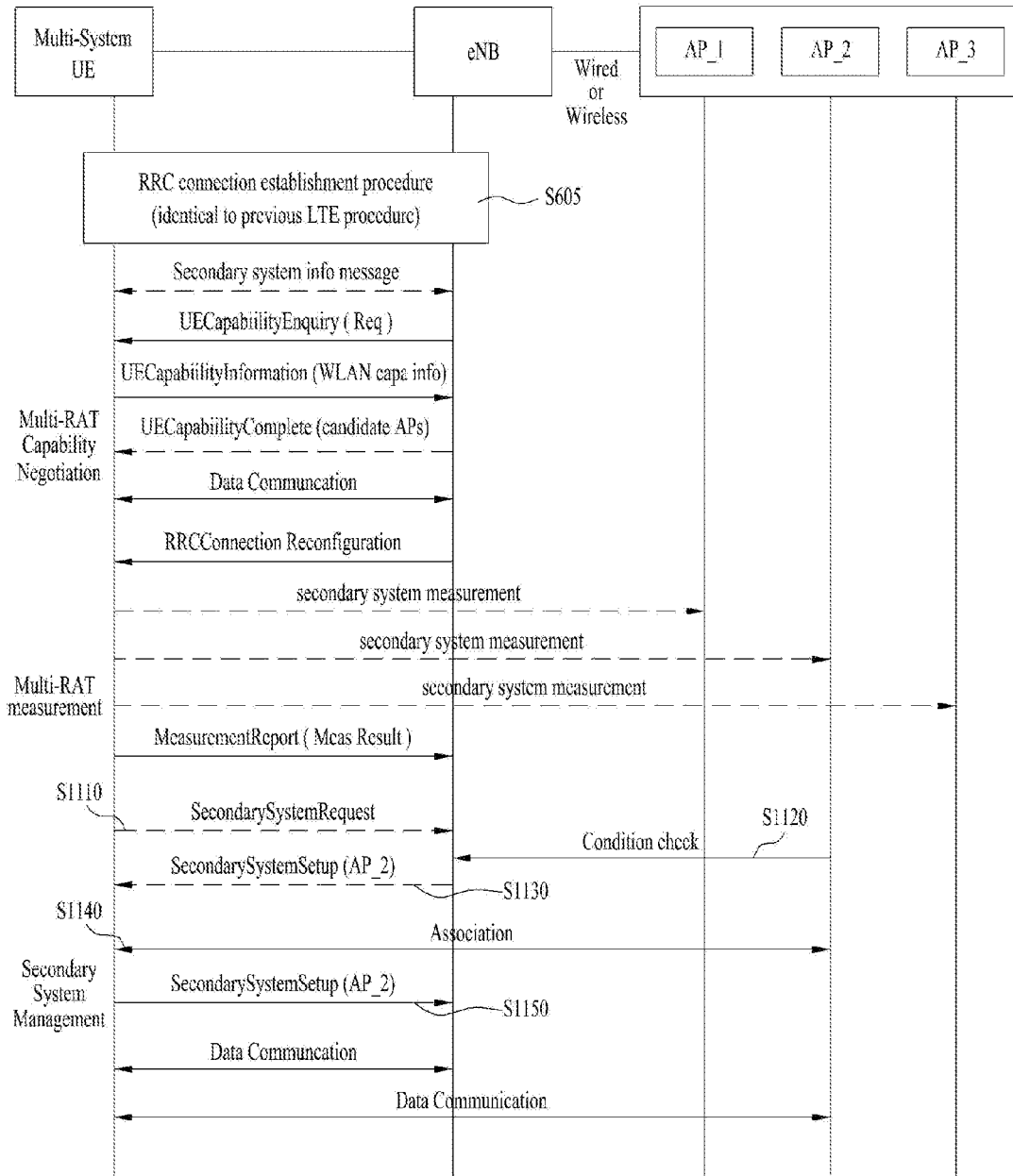

FIG. 12

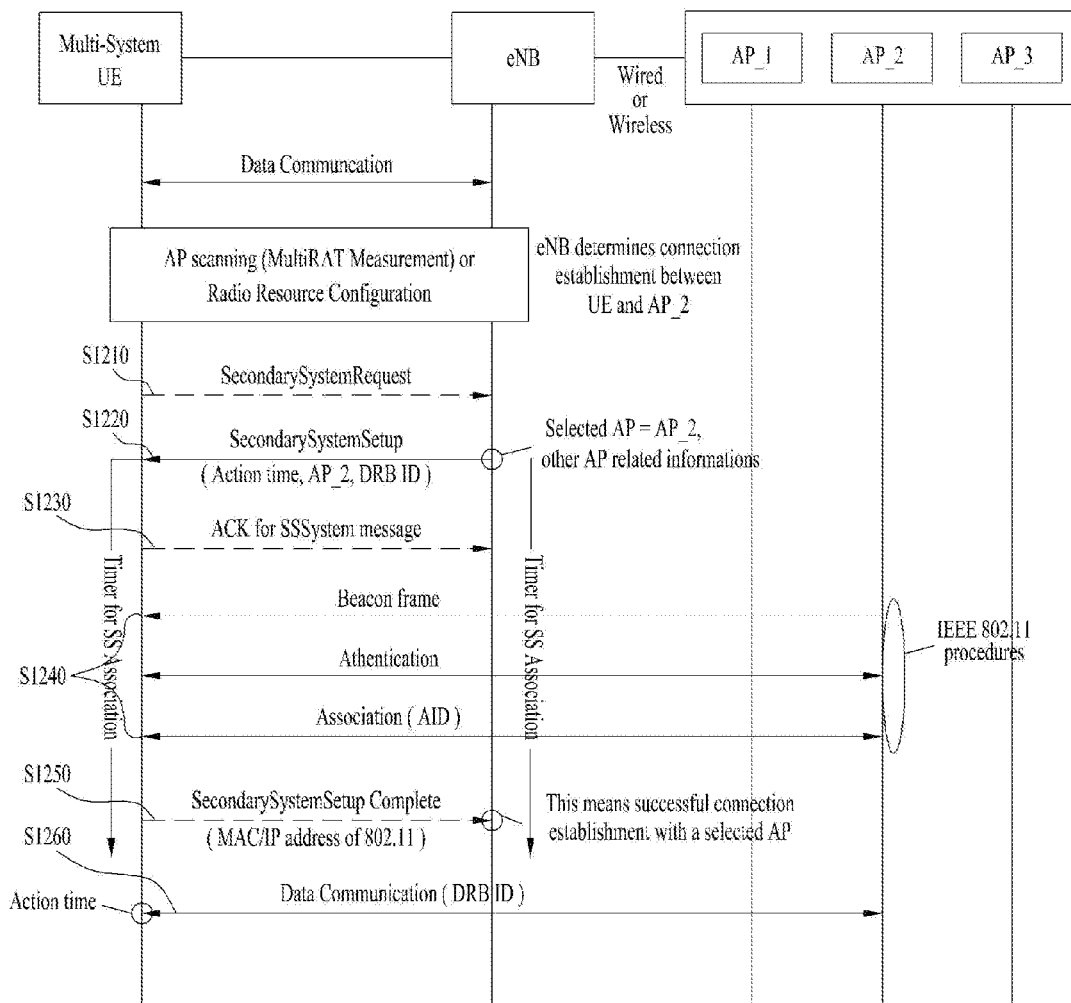

FIG. 13

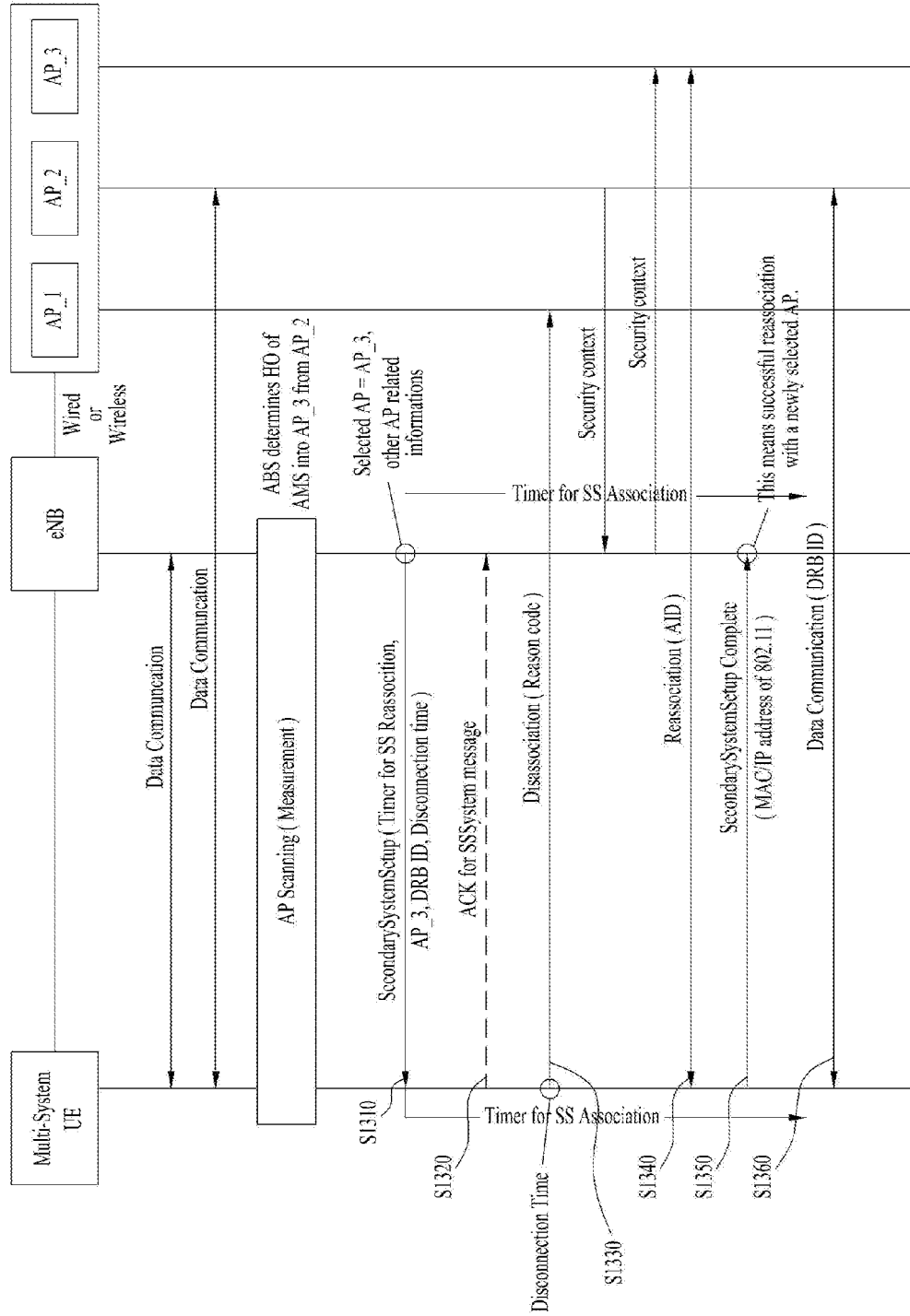

FIG. 14a

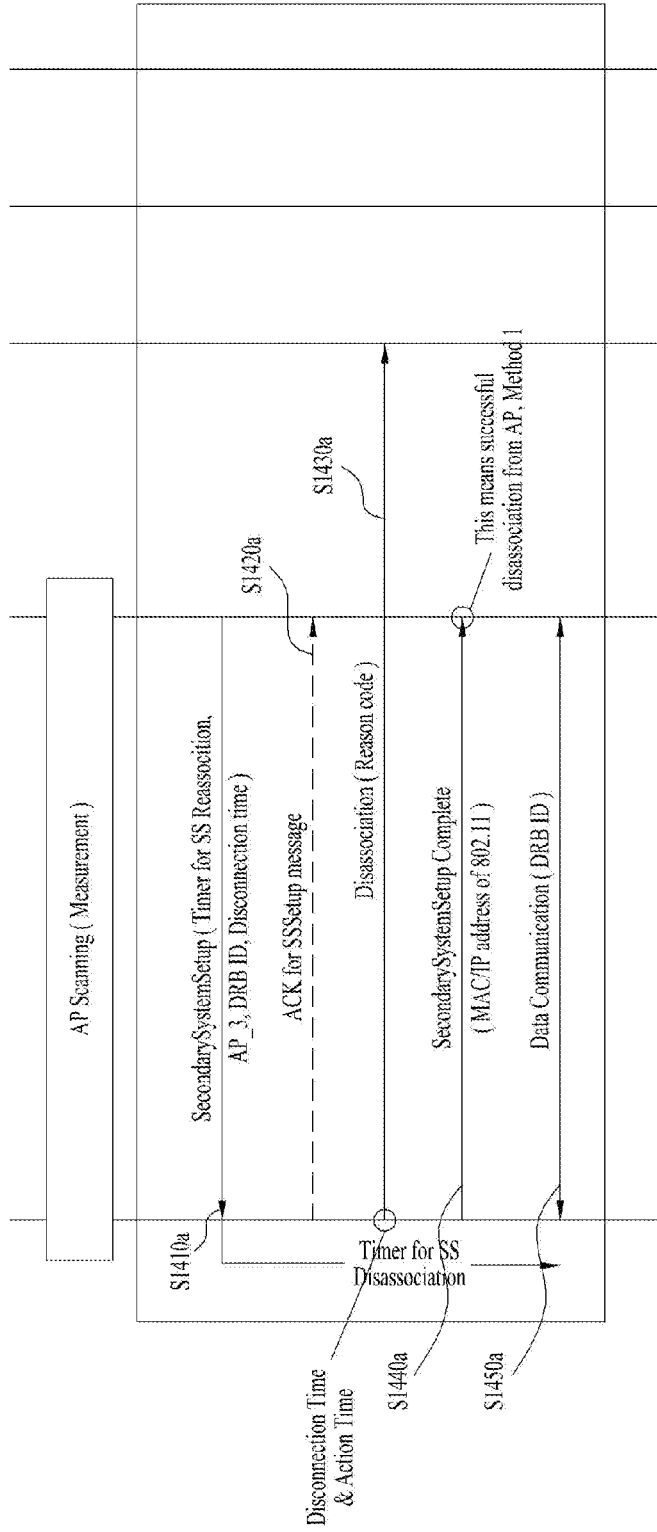

FIG. 14b

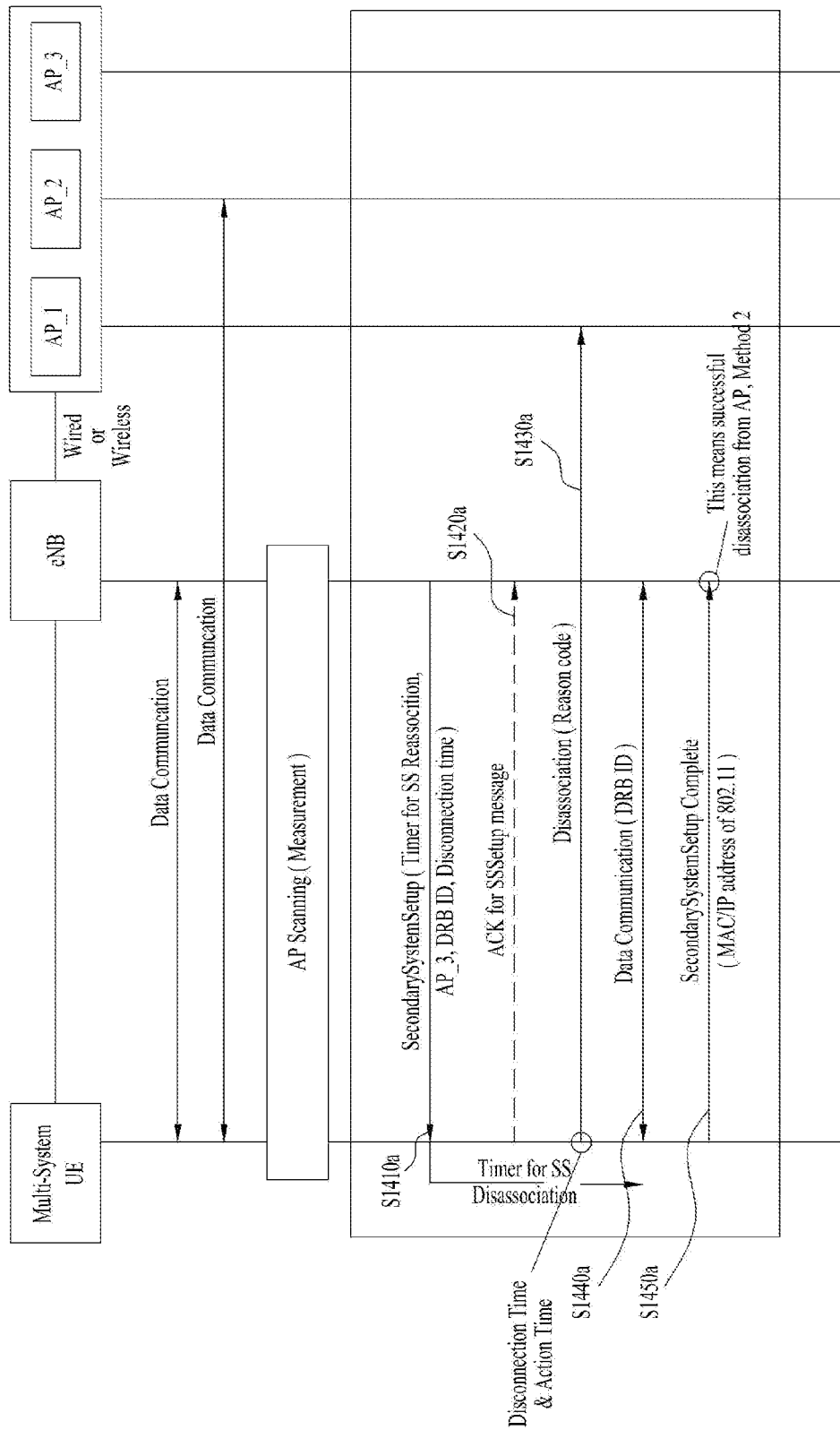
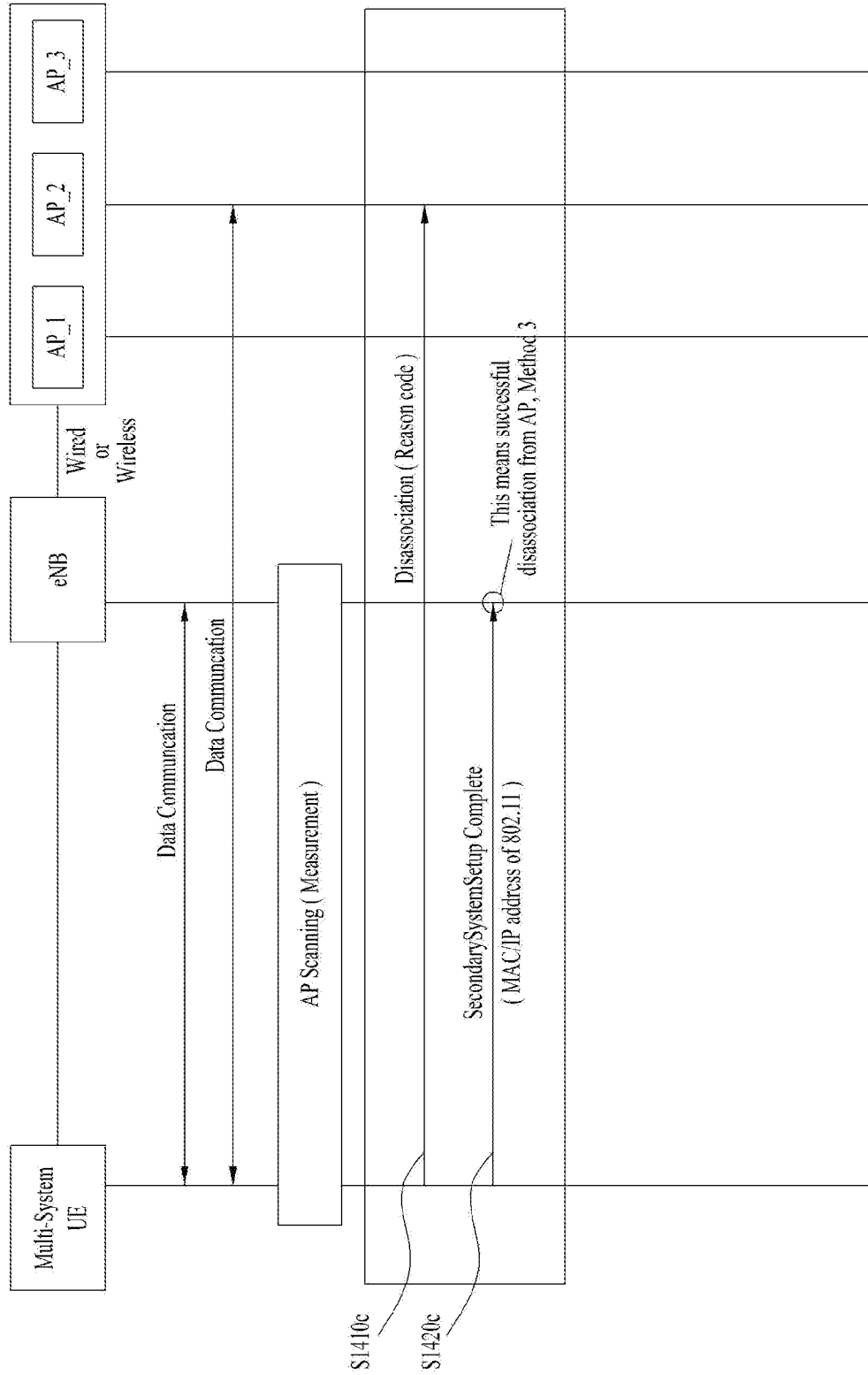

FIG. 14c



1

**METHOD OF SUPPORTING SIGNAL
TRANSMISSION AND RECEPTION USING
AT LEAST TWO RADIO ACCESS
TECHNOLOGIES AND APPARATUS
THEREFOR**

This application is a Continuation of U.S. patent application Ser. No. 14/417,026 filed Jan. 23, 2015, which is a 35 U.S.C. §371 National Stage Entry of International Application No. PCT/KR2013/006745 filed Jul. 26, 2013, which claims benefit of and priority to U.S. Provisional Application No. 61/809,423 filed Apr. 8, 2013, 61/699,263 filed Sep. 10, 2012, 61/693,759 filed Aug. 27, 2012, 61/692,241 filed Aug. 23, 2012, and 61/676,312 filed Jul. 26, 2012, all of which are incorporated by reference for all purposes as if fully set forth herein.

TECHNICAL FIELD

The present invention relates to a wireless communication, and more particularly, to a method of supporting signal transmission and reception using at least two radio access technologies (RATs) and apparatus therefor.

BACKGROUND ART

There may exist a multi-RAT user equipment having capability of accessing at least two radio access technologies (RATs). In order to access a specific radio access technology (hereinafter abbreviated RAT), a connection to the specific RAT is established on the basis of a user equipment request and data transmission and reception may be then performed. Yet, even if the multi-RAT user equipment is capable of accessing at least two RATs, it is unable to access a plurality of RATs at the same time. In particular, currently, even if a user equipment has multi-RAT capability, it is unable to simultaneously perform data transmission/reception through different RATs.

The above-mentioned multi-RAT technology of the related art is a switching based multi-RAT technology. Since all transmitted data are transmitted in a manner of being switched to another RAT, the related art multi-RAT technology has a problem in selecting an RAT suitable for characteristics of a flow. However, a solution for this problem has not been proposed yet.

DISCLOSURE OF THE INVENTION

Technical Tasks

One technical task intended to achieve by the present invention is to provide a method for a user equipment to support a signal transmission and reception using two or more radio access technologies (RATs).

Another technical task intended to achieve by the present invention is to provide a method for a base station to support a signal transmission and reception using two or more radio access technologies (RATs).

Another technical task intended to achieve by the present invention is to provide a user equipment supporting a signal transmission and reception using two or more radio access technologies (RATs).

The other technical task intended to achieve by the present invention is to provide a base station supporting a signal transmission and reception using two or more radio access technologies (RATs).

2

Technical tasks obtainable from the present invention are non-limited the above mentioned technical tasks. And, other unmentioned technical tasks can be clearly understood from the following description by those having ordinary skill in the technical field to which the present invention pertains.

Technical Solution

To achieve these and other advantages and in accordance with the purpose of the present invention, as embodied and broadly described, according to one embodiment, a method of supporting signal transmission and reception using two or more radio access technologies (RATs), which is supported by a user equipment can include the steps of

receiving a setup message indicating access to a second base station of a second communication network supporting a second RAT from a first base station of a first communication network supporting a first RAT and attempting to access the second base station. In this case, if the access to the second base station is successfully performed, data on a specific traffic type is transmitted and received via the second base station and data except the data on the specific traffic type may be transmitted and received via the first base station.

The setup message may include flow information indicating the specific traffic type, which is to be transmitted and received via the second base station.

Additionally, the setup message may include action time information indicating a timing of communicating with the second base station. If the setup message includes the action time information, the user equipment may begin to transceive data with the second base station on a timing indicated by the action time information.

The method of supporting signal transmission and reception using two or more radio access technologies (RATs), which is supported by the user equipment, may further include the step of transmitting a completion message, which is used to report whether the access to the second base station is successful, to the first base station.

In this case, the completion message may be transmitted only when the user equipment successfully accesses the second base station.

The completion message may include a status value indicating whether the access to the second base station is successful.

Additionally, the completion message may include an address value received from the second base station by the user equipment.

If the access to the second base station fails, the method of supporting signal transmission and reception using two or more radio access technologies (RATs), which is supported by the user equipment, may further include the step of receiving the setup message indicating an access to a new second base station from the first base station again.

If the second base station of a predetermined condition is searched, the method of supporting signal transmission and reception using two or more radio access technologies (RATs), which is supported by the user equipment, may further include the step of transmitting a request message requesting an access to the second base station to the first base station.

In this case, if the user equipment detects a second base station preferred by the user equipment, the predetermined condition detects the preferred second base station and the predetermined condition may be configured by at least one of a case that a measurement result for the preferred second base station is higher than a threshold and a case that a

measurement result for the second base station is higher than a measurement result for the first base station.

To further achieve these and other advantages and in accordance with the purpose of the present invention, according to a different embodiment, a method of supporting signal transmission and reception using two or more radio access technologies (RATs), which is supported by a first base station of a first communication network supporting a first RAT, includes the steps of transmitting a setup message indicating access to a second base station of a second communication network supporting a second RAT to a user equipment supporting the two or more RATs and receiving a completion message, which is used to report whether the access to the second base station is successful, from the user equipment. In this case, if the user equipment successfully accesses the second base station, data on a specific traffic type among data to be transmitted to the user equipment changes a transmission path to the second base station and data except the data on the specific traffic type are directly transmitted to the user equipment.

The setup message may include flow information indicating the specific traffic type, which is to be transmitted and received via the second base station.

Additionally, the setup message may include action time information indicating a communication timing between the user equipment and the second base station. If the setup message includes the action time information, the first base station may change the transmission path of the data on the specific traffic type to the second base station on a timing indicated by the action time information.

If the user equipment fails to access the second base station, the method of supporting signal transmission and reception using two or more radio access technologies (RATs), which is supported by a first base station of a first communication network supporting a first RAT, may further include the step of retransmitting the setup message indicating access to a new second base station to the user equipment.

In this case, if the completion message is not received until a timer, which is started after the setup message is transmitted, elapses, the first base station may determine that access establishment between the user equipment and the second base station fails.

As a different example, the first base station may determine whether the access establishment is successful via a status value included in the completion message indicating whether the user equipment succeeds in accessing the second base station.

The completion message includes an address value received from the second base station by the user equipment and the first base station may change the transmission path of the data on the specific traffic type based on the address value.

To further achieve these and other advantages and in accordance with the purpose of the present invention, according to a further different embodiment, a user equipment supporting signal transmission and reception using two or more radio access technologies (RATs) may include a communication unit and a processor, the processor configured to control the communication unit to receive a setup message indicating access to a second base station of a second communication network supporting a second RAT from a first base station of a first communication network supporting a first RAT, the processor configured to control the communication unit to attempt to access the second base station. If the access to the second base station is successfully performed, data on a specific traffic type is transmitted

and received via the second base station and data except the data on the specific traffic type may be controlled to be transmitted and received via the first base station.

To further achieve these and other advantages and in accordance with the purpose of the present invention, according to a further different embodiment, a base station of a first communication network supporting a first RAT, which supports signal transmission and reception using two or more radio access technologies (RATs), may include a communication unit and a processor, the processor configured to control the communication unit to transmit a setup message indicating access to a second base station of a second communication network supporting a second RAT to a user equipment supporting the two or more RATs, the processor configured to control the communication unit to receive a completion message, which is used to report whether the access to the second base station is successful, from the user equipment. If the user equipment successfully accesses the second base station, data on a specific traffic type among data to be transmitted to the user equipment changes a transmission path to the second base station and data except the data on the specific traffic type may be controlled to be directly transmitted to the user equipment.

Advantageous Effects

According to various embodiments of the present invention, a user equipment supporting both a cellular and a WLAN may efficiently perform selection of a heterogeneous network for a flow via a control of a cellular network in a wideband wireless communication system.

According to various embodiments of the present invention, a multi-RAT access method of a non-switching scheme may be provided in a wideband wireless communication system.

Effects obtainable from the present invention may be non-limited by the above mentioned effect. And, other unmentioned effects may be clearly understood from the following description by those having ordinary skill in the technical field to which the present invention pertains.

DESCRIPTION OF DRAWINGS

The accompanying drawings, which are included to provide a further understanding of the invention and are incorporated in and constitute a part of this application, illustrate embodiment(s) of the invention and together with the description serve to explain the principle of the invention. The above and other aspects, features, and advantages of the present invention will become more apparent upon consideration of the following description of preferred embodiments, taken in conjunction with the accompanying drawing figures. In the drawings:

FIG. 1 is a block diagram for configurations of a base station **105** and a user equipment **110** in a wireless communication system **100**;

FIG. 2 is a diagram for one example of a network structure to describe an interoperating structure of a first communication system (e.g., LTE system) and a second communication system (e.g., WiFi system);

FIG. 3A and FIG. 3B are diagrams for examples to describe scenarios according to the present invention;

FIG. 4 is a diagram for one example to describe a multi-system capability related negotiation procedure according to the present invention;

FIG. 5 is a diagram for one example to describe traffic characteristics in LTE system;

5

FIG. 6 is a diagram to describe a system selecting method using QoS class defined in LTE;

FIG. 7 is a diagram for one example to describe a measurement gap in LTE system;

FIG. 8 is a flowchart of a process for a UE to report a measurement result to an eNB;

FIG. 9 is a diagram for one example to describe a measurement object and a report configuration for a measurement result;

FIG. 10 is a diagram of enumerated trigger conditions;

FIG. 11 is a flowchart to describe a message defined for a secondary system management procedure;

FIG. 12 is a flowchart to describe an additional procedure of a secondary system;

FIG. 13 is a flowchart to describe a changing procedure of a secondary system; and

FIGS. 14A to 14C are flowcharts to describe a deleting procedure of a secondary system.

BEST MODE

Mode for Invention

Reference will now be made in detail to the preferred embodiments of the present invention, examples of which are illustrated in the accompanying drawings. In the following detailed description of the invention includes details to help the full understanding of the present invention. Yet, it is apparent to those skilled in the art that the present invention may be implemented without these details. For instance, although the following descriptions are made in detail on the assumption that a mobile communication system includes 3GPP LTE/LTE-A system, the following descriptions are applicable to other random mobile communication systems in a manner of excluding unique features of the 3GPP LTE/LTE-A.

Occasionally, to prevent the present invention from getting vaguer, structures and/or devices known to the public are skipped or may be represented as block diagrams centering on the core functions of the structures and/or devices. Wherever possible, the same reference numbers will be used throughout the drawings to refer to the same or like parts.

Besides, in the following description, assume that a terminal is a common name of such a mobile or fixed user stage device as a user equipment (UE), a mobile station (MS), an advanced mobile station (AMS) and the like. And, assume that a base station (BS) is a common name of such a random node of a network stage communicating with a terminal as a Node B (NB), an eNode B (eNB), an access point (AP) and the like. Although the present specification is described based on IEEE 802.16 system, contents of the present invention may be applicable to various kinds of other communication systems.

In a mobile communication system, a user equipment is able to receive information in downlink and is able to transmit information in uplink as well. Informations transmitted or received by the user equipment node may include various kinds of data and control informations. In accordance with types and usages of the informations transmitted or received by the user equipment, various physical channels may exist.

The following descriptions are usable for various wireless access systems including CDMA (code division multiple access), FDMA (frequency division multiple access), TDMA (time division multiple access), OFDMA (orthogonal frequency division multiple access), SC-FDMA (single carrier frequency division multiple access) and the like.

6

CDMA may be implemented by such a radio technology as UTRA (universal terrestrial radio access), CDMA 2000 and the like. TDMA may be implemented with such a radio technology as GSM/GPRS/EDGE (Global System for Mobile communications)/General Packet Radio Service/Enhanced Data Rates for GSM Evolution). OFDMA may be implemented with such a radio technology as IEEE 802.11 (Wi-Fi), IEEE 802.16 (WiMAX), IEEE 802.20, E-UTRA (Evolved UTRA), etc. UTRA is a part of UMTS (Universal Mobile Telecommunications System). 3GPP (3rd Generation Partnership Project) LTE (long term evolution) is a part of E-UMTS (Evolved UMTS) that uses E-UTRA. The 3GPP LTE adopts OFDMA in DL and SC-FDMA in UL. And, LTE-A (LTE-Advanced) is an evolved version of 3GPP LTE. Moreover, in the following description, specific terminologies are provided to help the understanding of the present invention. And, the use of the specific terminology may be modified into another form within the scope of the technical idea of the present invention.

FIG. 1 is a block diagram for configurations of a base station 105 and a user equipment 110 in a wireless communication system 100.

Although one base station 105 and one user equipment 110 (D2D user equipment included) are shown in the drawing to schematically represent a wireless communication system 100, the wireless communication system 100 may include at least one base station and/or at least one user equipment.

Referring to FIG. 1, a base station 105 may include a transmitted (Tx) data processor 115, a symbol modulator 120, a transmitter 125, a transceiving antenna 130, a processor 180, a memory 185, a receiver 190, a symbol demodulator 195 and a received (Rx) data processor 197. And, a user equipment 110 may include a transmitted (Tx) data processor 165, a symbol modulator 170, a transmitter 175, a transceiving antenna 135, a processor 155, a memory 160, a receiver 140, a symbol demodulator 155 and a received (Rx) data processor 150. Although the base station/user equipment 105/110 includes one antenna 130/135 in the drawing, each of the base station 105 and the user equipment 110 includes a plurality of antennas. Therefore, each of the base station 105 and the user equipment 110 of the present invention supports an MIMO (multiple input multiple output) system. And, the base station 105 according to the present invention may support both SU-MIMO (single user-MIMO) and MU-MIMO (multi user-MIMO) systems.

In downlink, the transmitted data processor 115 receives traffic data, codes the received traffic data by formatting the received traffic data, interleaves the coded traffic data, modulates (or symbol maps) the interleaved data, and then provides modulated symbols (data symbols). The symbol modulator 120 provides a stream of symbols by receiving and processing the data symbols and pilot symbols.

The symbol modulator 120 multiplexes the data and pilot symbols together and then transmits the multiplexed symbols to the transmitter 125. In doing so, each of the transmitted symbols may include the data symbol, the pilot symbol or a signal value of zero. In each symbol duration, pilot symbols may be contiguously transmitted. In doing so, the pilot symbols may include symbols of frequency division multiplexing (FDM), orthogonal frequency division multiplexing (OFDM), or code division multiplexing (CDM).

The transmitter 125 receives the stream of the symbols, converts the received stream to at least one or more analog signals, additionally adjusts the analog signals (e.g., amplification, filtering, frequency upconverting), and then gener-

ates a downlink signal suitable for a transmission on a radio channel. Subsequently, the downlink signal is transmitted to the user equipment via the antenna 130.

In the configuration of the user equipment 110, the receiving antenna 135 receives the downlink signal from the base station and then provides the received signal to the receiver 140. The receiver 140 adjusts the received signal (e.g., filtering, amplification and frequency downconverting), digitizes the adjusted signal, and then obtains samples. The symbol demodulator 145 demodulates the received pilot symbols and then provides them to the processor 155 for channel estimation.

The symbol demodulator 145 receives a frequency response estimated value for downlink from the processor 155, performs data demodulation on the received data symbols, obtains data symbol estimated values (i.e., estimated values of the transmitted data symbols), and then provides the data symbols estimated values to the received (Rx) data processor 150. The received data processor 150 reconstructs the transmitted traffic data by performing demodulation (i.e., symbol demapping, deinterleaving and decoding) on the data symbol estimated values.

The processing by the symbol demodulator 145 and the processing by the received data processor 150 are complementary to the processing by the symbol modulator 120 and the processing by the transmitted data processor 115 in the base station 105, respectively.

In the user equipment 110 in uplink, the transmitted data processor 165 processes the traffic data and then provides data symbols. The symbol modulator 170 receives the data symbols, multiplexes the received data symbols, performs modulation on the multiplexed symbols, and then provides a stream of the symbols to the transmitter 175. The transmitter 175 receives the stream of the symbols, processes the received stream, and generates an uplink signal. This uplink signal is then transmitted to the base station 105 via the antenna 135.

In the base station 105, the uplink signal is received from the user equipment 110 via the antenna 130. The receiver 190 processes the received uplink signal and then obtains samples. Subsequently, the symbol demodulator 195 processes the samples and then provides pilot symbols received in uplink and a data symbol estimated value. The received data processor 197 processes the data symbol estimated value and then reconstructs the traffic data transmitted from the user equipment 110.

The processor 155/180 of the user equipment/base station 110/105 directs operations (e.g., control, adjustment, management, etc.) of the user equipment/base station 110/105. The processor 155/180 may be connected to the memory unit 160/185 configured to store program codes and data. The memory 160/185 is connected to the processor 155/180 to store operating systems, applications and general files.

The processor 155/180 may be called one of a controller, a microcontroller, a microprocessor, a microcomputer and the like. And, the processor 155/180 may be implemented using hardware, firmware, software and/or any combinations thereof. In the implementation by hardware, the processor 155/180 may be provided with one of ASICs (application specific integrated circuits), DSPs (digital signal processors), DSPDs (digital signal processing devices), PLDs (programmable logic devices), FPGAs (field programmable gate arrays), and the like.

Meanwhile, in case of implementing the embodiments of the present invention using firmware or software, the firmware or software may be configured to include modules, procedures, and/or functions for performing the above-

explained functions or operations of the present invention. And, the firmware or software configured to implement the present invention is loaded in the processor 155/180 or saved in the memory 160/185 to be driven by the processor 155/180.

Layers of a radio protocol between a user equipment and an base station may be classified into first layer L1, second layer L2 and third layer L3 based on 3 lower layers of OSI (open system interconnection) model well known to communication systems. A physical layer belongs to the first layer and provides an information transfer service via a physical channel. RRC (radio resource control) layer belongs to the third layer and provides control radio resourced between UE and network. A user equipment and a base station may be able to exchange RRC messages with each other via radio communication layer and RRC layers.

In the present specification, the processor 155 of the user equipment 110 performs operations of processing signals and data except a signal transceiving function of the user equipment 110 and a storing function of the user equipment 110. And, the processor 180 of the base station 105 performs operations of processing signals and data except a signal transceiving function of the user equipment 110 and a storing function of the user equipment 110. Yet, for clarity of the following description, the processors 155 and 180 shall not be mentioned overall. Although the processor 155/180 is not mentioned specially, the processor 155/180 may be regarded as performing a series of operations including data processing and the like except a signal transceiving function and a storing function.

The present invention proposes a method for a user equipment, which supports both a cellular network and a wireless LAN network (e.g., WLAN) in a broadband wireless communication system, to efficiently perform a heterogeneous network selection for a flow through a control of the cellular network.

FIG. 2 is a diagram for one example of a network structure to describe an interoperating structure of a first communication system (e.g., LTE system) and a second communication system (e.g., WiFi system).

In the network structure shown in FIG. 2, a backhaul control connection is established between an AP and an eNB through a backbone network (e.g., P-GW, EPC (evolved packet core), etc.) or a wireless control connection may be established between the AP and the eNB. For peak throughput and data traffic off-loading, a user equipment (hereinafter abbreviated UE) is able to support both a first communication system (or a first communication network) using a first wireless communication scheme and a second communication system (or a second communication network) using a second communication scheme through interoperations among a plurality of communication networks. In this case, the first communication network and the first communication system may be named a primary network and a primary system, respectively. The second communication network and the second communication system may be named a secondary network and a secondary communication system, respectively. For instance, the UE may be configured to simultaneously support LTE (or LTE-A) and WiFi (e.g., a short range communication system such as WLAN, 802.11, etc.). Such a UE may be named a multi-system capability UE in the present specification.

In the network structure shown in FIG. 2, the primary system has a wider coverage and may include a network for control information transmission. For example, the primary system may include one of WiMAX system, LTE system and the like. On the other hand, the secondary system is a

network having a smaller coverage and may include a system for data transmission. For example, the secondary network may include a wireless LAN system such as WLAN, WiFi and the like.

FIG. 3A and FIG. 3B are diagrams for examples to describe scenarios according to the present invention.

FIG. 3A shows a first scenario having a backhaul control connection established between an AP and an eNB (i.e., a base station) via a backbone network. And, FIG. 3B shows a second scenario capable of a direct communication owing to a wireless control connection established between an AP and an eNB. In aspect of the eNB in each of the scenarios, the AP of a secondary system may look like an entity operating in a manner identical to that of a UE having LTE capability.

In the following description, definitions related to a multi-RAT system of the present invention are explained.

Primary System

A primary system (e.g., WiMAX, LTE network, etc.) is a system having a wider coverage. And, the primary system means a network in a connected state in a network having a constant status (or RRC connection) with a multi-system capability UE or a network in a DRX (discontinuous reception) or idle status.

A multi-system capability UE may send an indication, which indicates that the multi-system capability UE has capability for a heterogeneous network (e.g., WLAN, etc.), to an eNB of a primary system during a connection establishment with a primary network. In this case, the indication of the multi-system capability may be transmitted in a manner of being included as a new field in RRCConnectionRequest or RRCConnectionSetup message. If the indication of the multi-system capability is set to 1, a UE and an eNB may share capability necessary for a multi-system through a specific procedure for the multi-system capability UE.

An eNB of a primary system may periodically transmit information on another system (secondary systems) belonging to the same coverage for multi-system UEs using a broadcast message or a unicast message. If deployment of a secondary system is changed, it is able to send an updated message to indicate added/deleted/changed information of the secondary system.

Secondary System

A secondary system is a system having a small coverage and may include one of WLAN system, WiFi system and the like for example. The secondary system is the system that may be added or deleted if necessary. The secondary system may be mainly used for data transmission and reception that requires higher bandwidth (BW). In doing so, a specific flow (QoS) may be mapped.

A connection or release between a secondary system and a UE is possible after confirmation from a primary system. In this case, the connection between a secondary system and a UE may mean that it is ready to transmit/receive data or that data is transmitted/received.

If it is detected that a UE has entered a secondary system coverage, information on an access to a secondary system may be received through a primary system. In doing so, actual data transmission/reception may not occur instantly.

If a UE has data to transmit/receive via a secondary system, it is able to receive access information on a corresponding flow through a primary system. In doing so, actual data transmission/reception may occur instantly.

FIG. 4 is a diagram for one example to describe a multi-system capability related negotiation procedure according to the present invention.

FIG. 4 is provided for UE capability negotiation on the basis of LTE and shows a process for an eNB, which has capability for a heterogeneous network interoperating technology such as a wireless LAN, to receive a heterogeneous network related information of a UE by sending UE CapabilityEnquiry message to the UE.

Referring to FIG. 4, a UE (i.e., a multi-system capability UE) performs an initial network entry procedure with a primary system (i.e., an eNB of the primary system) [S410]. In particular, the UE performs an initial connection establishment with the primary system. In case that the primary system includes an LTE system, the UE performs an initial RRC (radio resource control) connection establishment of the previous LTE. In the initial network entry procedure, the corresponding UE may inform a base station that the corresponding UE is the multi-system or multi-RAT capability UE. For instance, the UE may send the corresponding indication to the base station through RRCConnectionRequest message or in the course of RRCConnectionSetup procedure. In particular, such a parameter (e.g., 1-bit size) as 'MultiRATAccessAvaialble' may be transmitted in a manner of being added to the RRCConnectionRequest message or the RRCConnectionSetup procedure.

If there is a common information, which should be received by the UE, of a base station (hereinafter called an AP (access point)) of a secondary system, a base station (hereinafter called an eNB) of the primary system may transmit an information on the secondary system to the UE [S420].

On the other hand, unlike the description of the step S410 with reference to FIG. 4, the multi-system (or multi-RAT) capability negotiation may be performed after the initial connection establishment.

In case of a connection reestablishment, the multi-system (or multi-RAT) capability negotiation may be skipped. In case of a handover, a target eNB may perform a pre-negotiation through a backbone network from a serving eNB. After the UE has entered RRC-IDLE state, the eNB may store the multi-system capability of the UE for predetermined duration. If a network reconfiguration is performed before multi-system information retain timeout, the negotiation may be omitted.

The eNB may send a message, which queries the capability of the UE (e.g., whether the UE is capable of accessing the multi-system or the multi-RAT simultaneously, whether the UE is capable to simultaneously accessing a prescribed system and a prescribed RAT, etc.), to the UE [S430]. This message may be named 'UECapabilityEnquiry'. As a UE-CapabilityRequest parameter is added to the UE CapabilityEnquiry message, the UE CapabilityEnquiry is sent with a content of the added parameter to query whether the UE is capable of supporting the multi-system or the multi-RAT simultaneously or whether the UE is capable of supporting a prescribed system. In this case, the UE-CapabilityRequest parameter may be transmitted in a manner of including a parameter about such a new radio access technology (RAT) (i.e., an unlicensed band) as WiFi, WLAN, 802.11 and the like.

In response to the UE CapabilityEnquiry message, the UE sends a UE CapabilityInformation message to the eNB [S440]. This UE CapabilityInformation message may contain WiFi related capability information for example.

The UE CapabilityInformation message may include an indicator indicating capability of simultaneously accessing a plurality of radio access technologies or system types and information on supportable radio access technologies or system types. For instance, if the supportable ratio

11

access technology includes WiFi, the UECapabilityInformation message may contain 802.11 MAC address (for authentication information) of the UE in addition. The UECapabilityInformation message may contain a previously accessed AP information (UE's preferred AP). And, the information is preferably transmitted to the eNB to which the previously accessed AP belongs. And, the UECapabilityInformation message may additionally contain Protocol Version (11 a/b/n . . .) information and information on a type or characteristic (e.g., EPS bearer QoS type) of a traffic desired to be transmitted or received via WLAN. This information of the traffic type or characteristic shall be described in detail later.

Thus, as the UE and the eNB exchange the UECapabilityEnquiry message and the UECapabilityInformation message with each other, the following content shown in Table 1 needs to be additionally included in the previous standard specification 3GPP TS 36.331.

TABLE 1

Insert below description to 5.6.3.3 Reception of the UE Capability Enquiry by the UE (3GPP TS 36.331)

The UE shall:

1> set the contents of UECapability Information message as follows:

2> if the ue-CapabilityRequest includes wifi and if the UE supports WiFi (or WLAN or 802.11x) domain:

3> include the UE radio access capabilities for WiFi within a ue-CapabilityRAT-Container and with the rat-Type set to WiFi(or WLAN or 802.11x);

1> submit the UECapabilityInformation message to lower layers for transmission, upon which the procedure ends

Having received the supportable radio access technology or system type information through the UECapabilityInformation message, the eNB sends UECapabilityComplete or UECapabilityResponse message [S450]. In this case, the UECapabilityComplete or UECapabilityResponse message may contain candidate APs information.

In the case shown in FIG. 4, only if a previous UECapabilityEnquiry message is sent (1 step), the UE sends the UECapabilityInformation message (2 step). In this case, the eNB may send the UECapabilityComplete message in response to the UECapabilityInformation message (3 step), which is an optional step. Hence, the MultiRAT capability negotiation procedure may include 2 or 3 steps.

Alternatively, the MultiRAT capability negotiation procedure may be configured to include 1 or 2 steps. In particular, without a previous UECapabilityEnquiry message, the UECapabilityInformation may be sent to the eNB in an unsolicited manner under the decision made by the UE (1 step). In this case, the eNB may send UECapabilityComplete message to the UE in response to the UECapabilityInformation message (optional) (2 steps).

After the step S450, the UE may exchange data with the eNB [S460]. Based on the candidate AP list (or APs) received in the step S450, the UE may select the AP by performing a secondary system scanning [S470]. After the scanning, the UE may perform a secondary system management [S480]. In this case, there is a trigger condition for a secondary system (e.g., AP) measurement. Prior to describing the definition of the trigger condition, QoS (quality of service) indicating a traffic state is schematically described with reference to 3GPP LTE system for example.

FIG. 5 is a diagram for one example to describe traffic characteristics in LTE system.

Referring to FIG. 5, if a UE accesses an LTE network, EPS (evolved packet system) Bearer is generated from the UE to P-GW (i.e., UE-eNB-S-GW-P-GW) [GTP type tun-

12

nel]. In particular, a plurality of EPS Bearers may be generated depending on each service property. For instance, Internet EPS Bearer, IPTV EPS Bearer, VoIP EPS Bearer and the like may be generated. Properties of Default EPS Bearer and Dedicated EPS Bearer are described as follows.

Default EPS Bearer—QoS property of Default EPS Bearer includes Non-GBR (Non-Guaranteed Bit Rate), e.g., Internet service.

Dedicated EPS Bearer—Dedicated EPS Bearer may be generated at GBR or Non-GBR. For instance, Dedicated EPS Bearer for VoD service is generated at GBR.

LTE QoS is described in brief as follows.

First of all, a previous LTE enables traffic characteristics to be defined on a network level (i.e., P-GW). In particular, the P-GW defines 5-tuple Service Data Flow and an eNB defines GBR or Non-GBR.

PDN connection: IP connection between UE and PDN (UE is identified with IP address, while PDN is identified with APN).

EPS session: Having the same meaning of PDN connection. This session has at least one EPS bearer. If IP address is assigned to a UE, this session is maintained as long as the UE is connected to an IP network.

EPS bearer: A delivery path established between UE and P-GW to transmit IP traffic with specific QoS. Each EPS bearer is configured with QoS parameters indicating property of the delivery path.

Default bearer: This is EPS bearer newly generated when a new PDN connection is established. This bearer is maintained until the PDN connection is terminated. This bearer is always configured at non-GBR.

Dedicated Bearer: This is EPS bearer generated on demand additionally after PDN connection establishment. Corresponding to GBR or non-GBR.

SDF (Service Data Flow): IP flow corresponding to a service or a set of IP flows. This flow is identified by an IP of packet and TCP/UDP header. A different QoS is applied per SDF and PCC rules are applied by PCRF. This flow is delivered on EPS bearer that meets QoS of SDF. Several SDFs may be mapped to the same EPS bearer. User traffic has a different QoS property depending on using what kind of service or application. SDF is an IP flow generated from filtering user traffic per service or a set of IP flows. And, a specific QoS policy is applied in accordance with a subscriber level of UE and a used service. IP flows toward a user are sorted into SDF through SDF template (classifier) in accordance with service property and are then delivered to a user in a manner of having QoS policy (e.g., bandwidth control) applied thereto per SDF. On EPS delivery network, QoS is transmitted in a manner of being mapped to EPS bearer.

EPS bearer: As mentioned in the foregoing description, EPS bearers may be sorted into a default type and a dedicated type. If a UE accesses an LTE network, an IP address is assigned to the UE. Then, the UE establishes a PCN connection as soon as EPS bearer is generated. While the UE uses a service (e.g., Internet) through default bearer, if the UE uses another service (e.g., VoD) that cannot be provided through the default bearer, dedicated bearer is generated by on-demand. In particular, the dedicated bearer is configured by QoS different from that of a previously configured bearer. UE may access several APNs. And, one default EPS bearer and sever dedicated EPS bearers may be configured per APN. Maximum 11 EPS bearers may be configured.

Default bearer is generated when a UE initially accesses a network. The default bearer keeps being maintained even

if a service is not used in the meantime. The default bearer then disappears when the UE leaves the network. One default bearer is generated per PAN. How to generate a default bearer by applying which QoS to a prescribed APN in case of an initial access to a network is provisioned as a user's subscription information in HSS. If a UE initially accesses a network, an MME downloads user's subscription information from an HSS and then generates default bearer with a corresponding PDN using subscriber QoS profile.

SDF QoS: QCI (QoS Class Identifier) and ARP (Allocation and Retention Priority) are basic parameters applied to all SDFs. QCI is an expression with integer values (1 to 9) by standardizing different QoS properties. And, the standardized QoS properties may be represented as resource type, priority, packet delay budget, packet error loss rate and the like. The SDF may be categorized into a GBR type SDF having a network resource allocated fixedly or a non-GBR type SDF having a network resource not allocated fixedly in accordance with a resource type. Besides QCI and ARP, GBR (Guaranteed Bit Rate) and MBR (Maximum Bit Rate) are assigned as QoS parameters to the GBR type SDF and MBR is assigned to the non-GBR type SDF.

GBR type SDF QoS parameter: QCI, ARP, GBR (DL/UL), MBR (DL/UL)

Non-GBR type SDF QoS parameter: QCI, ARP, MBR (DL/UL)

SDF is mapped to EPS bearer by P-GW and is then delivered to UE through the EPS bearer. SDFs (SDF aggregate) having the same QCI and ARP are mapped to one EPX bearer.

EPS Bearer QoS: QCI and ARP are basic QoS parameters applied to all EPS bearers. EPS bearer is categorized into GBR type bearer or non-GBR type bearer in accordance with QCI resource type. A default bearer is always non-GBR type and a dedicated bearer may be set to GBR or non-GBR. GBR type bearer QoS parameters may include QCI, ARP, GBR (DL/UL), and MBR (DL/UL). Non-GBR type bearer QoS parameters may include QCI, ARP, APN-AMBR (DL/UL), and UE-AMBR (DL/UL).

Besides QCI and ARP, the GBR type bearer has GBR and MBR as QoS parameters, which means that a fixed resource is allocated per bearer. On the other hand, the non-GBR type bearer has AMBR (Aggregated Maximum Bit Rate) as QoS parameter, which means that a maximum bandwidth usable together with other non-GBR type bearers is assigned instead of receiving resource application per bearer. APN-AMBR is a maximum bandwidth that may be shared within the same PDN by non-GBR type bearers and UE-AMBR is a maximum bandwidth sharable within the same UE. In case that UE has several PDN connections, a sum of APN-AMBRs of the PDNs cannot exceed UE-AMBR.

In the following description, definition of a trigger condition for a secondary system (e.g., AP) measurement is explained. In particular, a trigger condition for a UE to initiate other RAT measurement is described.

(1) A condition for a UE to start a measurement of neighbor AP in a step of not starting a measurement may be determined by a traffic transmitted on radio resource configuration) (e.g., DRB (Data Radio Bearer) addition. The condition may be determined in accordance with GBR, non-GBR or a new EPS bearer QoS type defined by the present invention. If a traffic desired to be transmitted via AP in case of Multi-RAT Capability Negotiation (S410, or S420 to S450) is defined and is generated through radio resource configuration, the UE may start the AP measurement.

(2) If IEEE 802.11 (WLAN, AP) is selected as a preferred system in radio resource configuration, a UE may start a measurement of neighbor AP.

Meanwhile, a metric for starting a measurement may be transmitted as a UE-specific value to a UE by an eNB through a unicast message. In the following description, a traffic type used to determine a trigger condition for a secondary system (e.g., AP) measurement is explained.

Traffic Characteristics in LTE

As traffics transmitted on a cellular network are diversified, if an eNB is aware of traffic characteristics and processes radio bearers appropriately, it may help enhancement of total system performance. Yet, a current LTE system discriminates a service data flow (SDF) on APN (p-GW) level only in accordance with a specific QoS policy, defines a QoS level, and then provides a service appropriate for it.

P-GW SDF-QoS-defines a service data flow sorted by 5-tuple (Source IP, Destination IP, Source Port number, Destination Port number, Protocol ID) in accordance with a QoS policy. The SDF QoS is mapped again to EPS bearer QoS. Currently, there are two types (default, dedicated) of EPS bearers in LTE.

Referring to FIG. 5, an eNB or LTE system defines LTE EPS bearer on a sub-divided QoS level using the corresponding SDF QoS definition and the eNB may provide a different service for each of the types. To this end, like SDF QoS, EPS bearers may be sorted by the following types (EPS bearer QoS types).

Ex.) voice (Conversational Real Time service), streaming video (streaming real time service), web browsing (Interactive BE service), telemetry/emails (Background BE service)

EPS Bearer type 1: This type corresponds to a default EPS bearer that is basically generated when a connection is established.

EPS Bearer type 2: Best Effort Service type

EPS Bearer type 3: Real time service

...

EPS Bearer type n: Streaming video service

FIG. 6 is a diagram to describe a system selecting method using QoS class defined in LTE.

Referring to FIG. 6, steps S605 to S630 sequentially correspond to the former steps S410 to S460 shown in FIG. 4, respectively. And, the contents of the S410 to S460 described with reference to FIG. 4 may be applied to the steps S605 to S630.

Subsequently, a UE may receive an RRC connection reconfiguration message (e.g., RRCConnectionReconfiguration message) from an eNB [S635]. A data radio bearer (DRB) may be transmitted in a manner of being added to the RRC connection reconfiguration message. As mentioned in the foregoing description of the trigger condition (1) for the UE to initiate measurement of a different radio access technology, whether to trigger a measurement of neighbor AP may be determined by a traffic type transmitted through the radio resource configuration (e.g., DRB addition). And, the trigger condition may be determined in accordance with GBR, Non-GBR, or a new EPS bearer QoS type (or traffic type) defined by a technology of the invention.

Thus, if a type of a traffic transmitted by being included in the RRCConnectionReconfiguration message corresponds to a traffic type that meets the trigger condition, the UE may perform a measurement on a base station (e.g., neighbor APs (AP1, AP2, AP3) shown in FIG. 6) that uses a different radio access technology [S640]. Thereafter, the UE reports a result of the measurement to the eNB [S645].

System Selecting Method Using QoS Class Defined in LTE

The technology of the present invention enables an eNB (or such a network entity as MultiRAT Management entity) to select a system appropriate for a traffic using EPS bearer type defined in the foregoing description. It may be difficult to select an appropriate system using the previous classification reference (i.e., GBR, non-GBR) for data flow. The technology of the present invention may determine an eNB to transmit a specific traffic type (or specific flow(s)) to a network (e.g., WLAN, i.e., a secondary system), which uses a radio access technology different from that of an LTE network in accordance with information received from a UE using the EPS bearer type defined in the foregoing description. To this end, the eNB delivers the traffic, which was transmitted in the step S620 and corresponds to a traffic type desired to be received via WLAN, to the AP. Subsequently, the UE receives the traffic, which corresponds to the traffic type desired to be received via the WLAN, from the AP and is also able to receive a traffic corresponding to another traffic type via LTE network at the same time.

If a network entity or eNB below S-GW manages flows of a multi-RAT UE, an RAT selection for a traffic (or flow) of the UE is performed in a following manner. First of all, an eNB receives information on a network (e.g., a secondary system), which uses a different radio access technology, from the UE. Secondly, the eNB analyzes the received information in a manner of comparing it to information on a serving cell (i.e., a cell in a currently connected primary system). Finally, the eNB selects an RAT for maximizing overall system performance. According to the present invention, the eNB is assumed as becoming a subject for the selection.

If a network entity above P-GW is capable of managing RAT of a UE, the corresponding network entity should be able to receive state information of the UE and state information of a heterogeneous network such as a cellular network, WLAN and the like. When traffic characteristics desired to be transmitted via wireless LAN (i.e., an access capable RAT in accordance with capability of UE) are shared between a UE and an eNB in case of multi-RAT capability negotiation, if a specific traffic is generated and corresponds to a traffic preferred to be transmitted via the wireless LAN (i.e., secondary system), the eNB controls a state of the wireless LAN (i.e., secondary system) to be searched using the above information.

Measurement Report

A data connection transmitted from an eNB to a UE is established by an RRC (radio resource configuration) procedure. Assuming that data for a specific RB (radio bearer) or LC (logical channel) is transmitted via a secondary system (e.g., AP) under the determination made by the eNB, if it is determined that the specific RB or LC needs to communicate with the secondary system (e.g., AP), the eNB may instruct the UE to scan neighbor APs.

In doing so, the eNB sends an RRCConnectionReconfiguration message to the UE, whereby the UE may initiate a measurement. In particular, the UE may initiate the measurement of AP by an active scanning (e.g., Probe Request transmission and Probe Response reception) or a passive scanning (e.g., Beacon reception).

In the RRCConnectionReconfiguration message, at least one of Measurement Configuration and Radio Resource Configuration may be included. The Measurement Configuration may include information for a UE to find a secondary system quickly. For instance, the Measurement Configuration may include at least one of SSID of AP neighbor to the

UE, a beacon transmission cycle, and a measurement gap information. The Radio Resource Configuration may carry a field for indicating traffic characteristics of a generated RB. For instance, in the Radio Resource Configuration, such a parameter value indicating traffic characteristics as EPS bearer QoS type, QCI, ARP GBR (DL/UL), MBR (DL/UL) and the like may be included.

If a trigger condition for a secondary system measure is already defined, the UE may initiate the measurement of AP on the condition that the trigger condition is met irrespective of a presence or non-presence of the reception of the RRCConnectionReconfiguration message from the eNB.

It may be unnecessary for the Measurement Configuration of the RRCConnectionReconfiguration message, which is mentioned in the above description, to include the information on the measurement gap all the time. In some cases, the information on the measurement gap may be omitted from the Measurement Configuration. This is described in detail with reference to FIG. 7 as follows.

FIG. 7 is a diagram for one example to describe a measurement gap in LTE system. A UE may use InterFreqRSTDMeasurementIndication message to instruct a network to start or stop a measurement of RSTD (Reference Signal Time Difference) between OTDOA (Observed Time Difference Of Arrival) frequency bands requiring a measurement gap.

If it is indicated that an upper layer starts the inter-frequency band RSTD measurement only, the UE is able to confirm a measurement gap required situation as soon as receive the indication from the upper layer. If a sufficient gap is available at this timing point, the UE may skip the transmission of the InterFreqRSTDMeasurementIndication message. Thereafter, even if the measurement gap gets insufficient, the UE may skip the transmission of the InterFreqRSTDMeasurementIndication message unless receiving a new indication from the upper layer.

If the upper layer indicates to stop performing the inter-frequency band RSTD measurement, the UE may send the InterFreqRSTDMeasurementIndication message despite having skipped the transmission of the InterFreqRSTDMeasurementIndication message in response to the previous indication indicating to start the inter-frequency band RSTD measurement.

Thus, it is necessary for a sufficient measurement gap to be configured for an inter-frequency band RSTD measurement in a switching based multi-RAT access system. Yet, the present invention relates to a non-switching based multi-RAT access system. According to the present invention, since a UE may access a secondary system without transferring a primary system, a measurement of the secondary system may be possible without configuring a measurement gap. Therefore, information on the measurement gap may be omitted from Measurement configuration of RRCConnectionReconfiguration.

The UE may set a given DRB as a single measurement object as well as a given frequency. In this case, the UE may explicitly indicate the measurement object in accordance with a radio access technology type (e.g., E-UTRAN, UTRAN, CDMA2000, GERAN, WLAN, etc.). In this case, a third layer may filter a measurement result on a first layer. As mentioned in the foregoing description, the inter-frequency band measurement may be performed in an idle interval including the measurement gap. Yet, a measurement of wInter-RAT (i.e., secondary system) may be performed without a measurement gap.

Generally, in order to maintain an optimal access to a base station, a UE should perform a measurement on at least one

of a serving base station and a neighbor base station to switch from a specific RAT to another RAT. The UE measures the serving base station and the base station in response to an indication of an eNB and is able to report a result of the measurement to the eNB.

Yet, if the result of the measurement of the at least one of the serving base station and the neighbor base station is insignificant, the measurement result may not be transmitted to the eNB. For instance, if a signal of the neighbor base station is considerably lower than that of the serving base station, it is able to raise system efficiency by not reporting the measurement result. Hence, only if a trigger condition of the measurement result is met, the UE may transmit the measurement result for the at least one of the serving base station and the neighbor base station to the eNB.

For instance, FIG. 8 is a flowchart of a process for a UE to report a measurement result to an eNB. Referring to FIG. 8, a UE receives RRC Configuration Reconfiguration message from an eNB [S801]. The UE performs a measurement [S802]. And, the UE may report a measurement result to the eNB using Measurement Report message [S804]. In doing so, the UE determines whether the following trigger condition is met [S803]. Only if the trigger condition is met, the UE may report a result of the measurement of at least one of a neighbor base station and a serving base station to the eNB.

A1: Serving base station gets better than a first threshold (threshold 1).

A2: Serving base station gets worse than the first threshold.

A3: Neighbor base station gets better than PCell (primary cell) by offset.

A4: Neighbor base station gets better than a second threshold (threshold 2).

A5: PCell gets worse than the first threshold and the neighbor base station gets better than the second threshold.

A6 (not shown in the drawing): Neighbor base station gets better than SCell (secondary cell) by offset (in CA (Carrier Aggregation) environment).

According to the present invention, a UE is not switched from a specific RAT to another RAT. Instead, while the UE maintains an access to a specific RAT (e.g., primary system), the present invention enables an access to another RAT (e.g., secondary system). Hence, measurement objects and reporting trigger conditions different from the above-enumerated **A1** to **A5** are applicable.

FIG. 9 is a diagram for one example to describe a measurement object and a report configuration for a measurement result. Referring to FIG. 9, a UE may set a frequency or DRB given per radio access technology as a measurement object. For instance, in a switching based multi-RAT access environment, a specific frequency (or cell) is a measurement object like a single E-UTRA carrier frequency, a set of cells on a single UTRA carrier frequency, a set of cells GERAN carrier frequencies, a set of cells on a single (HRPD or 1xRTT) carrier frequency and the like. On the other hand, in a non-switching based multi-RAT access environment like the present invention, a frequency may be set as a measurement object like a set of WLAN carrier frequencies or a DRB may be set as a measurement object like a set of E-UTRA data bearers (or flows) on a single E-UTRA carrier frequency, a set of WLAN data bearers (or flows) on a single WLAN carrier frequency and the like.

The UE gives a measurement ID for identifying a result of measurement of result of a measurement object and is then able to report the measurement ID given measurement result to the eNB. The measurement result reporting may

occur periodically. Alternatively, the measurement result reporting may occur if a trigger condition for the reporting is met.

In the non-switching based multi-RAT access environment, a UE may report a measurement result of a secondary system if the following trigger condition occurs.

B1: Case that an inter-RAT neighbor gets better than a second threshold.

B2: Case that PCell gets worse than a first threshold and an inter-RAT neighbor gets better than the second threshold.

B3: Case that an inter-RAT serving gets worse than the first threshold.

In the above enumerated conditions **B1** to **B3**, the inter-RAT may mean a base station (e.g., AP) of a secondary system. When a serving base station of a UE is a base station (e.g., eNB) of a primary system, the inter-RAT serving neighbor may mean that a serving base station of the UE is a base station (e.g., AP) of a secondary system.

FIG. 10 is a diagram of enumerated trigger conditions. **A1** to **A10** diagrammatize the trigger conditions in a switching based multi-RAT access environment. And, **B1** to **B3** diagrammatize the trigger conditions in a non-switching based multi-RAT access environment. In this case, a first threshold may be provided to determine whether a measurement result of a primary system (or a serving base station) is meaningful. And, a second threshold may be provided to determine whether a measurement result of a secondary system (or a neighbor base station) is meaningful.

A parameter value for a trigger condition for reporting may be transmitted to a UE via a reportConfigInterRAT message. In particular, the reportConfigInterRAT message may be broadcasted or unicast to a UE. When a measurement object is a DRB, the reportConfigInterRAT may be transmitted as UE-specific information to the UE by unicast.

The trigger conditions may be set to different values for each measurement object. For instance, each of the first and second thresholds may be defined as a different value depending on preference of AP or traffic characteristics of DRB.

For instance, a voice traffic may prefer to communicate via a primary system (e.g., a cellular network) rather than a secondary system (e.g., WLAN network). And, a data traffic may prefer to communicate via a secondary system rather than a primary system. Hence, a threshold value (e.g., a second threshold) for reporting a measurement result of the secondary system may be set high for the voice traffic. And, a threshold value (e.g., a second threshold) for reporting a measurement result of the secondary system may be set low for the data traffic. Thus, as the threshold values for reporting the measurement result may vary depending on a transmitted traffic, trigger conditions may be defined and transmitted in accordance with the traffic characteristics. As mentioned in the above description, the trigger condition may be defined differently in accordance with a traffic type (e.g., EPS bearer QoS type) of flow or traffic characteristics (e.g., GBR, non-GBR, etc.) of flow.

An eNB may provide a UE with a trigger condition for a reporting through RRCConnectionReconfiguration message. In particular, the eNB may provide the UE with the trigger condition through measConfig./radioResourceConfig of RRCConnectionReconfiguration. In case that the trigger conditions is defined in accordance with a traffic type or traffic characteristics of flow, the trigger condition for each flow (or RB) may be transmitted to the UE. In doing so, the eNB may transmit an appropriate trigger condition to the UE by unicast with reference to characteristics of a traffic transmitted through radio resource configuration.

Based on the trigger condition for the reporting, whether to report a measurement result may be determined or set in case of multi-RAT capability negotiation between the UE and the eNB.

For instance, although a signal strength of AP is lower than a threshold (e.g., second threshold) determined by the trigger condition, if a user intends to communicate using the AP, it may be necessary to report a measurement result of the AP irrespective of whether the trigger condition is met.

Hence, the UE may indicate whether the measurement result will be reported by the trigger condition in case of the multi-RAT capability negotiation. In particular, the UE may use 'measurement reporting by trigger condition' bit of UE Capability Information message to indicate whether the measurement result of the AP will be reported by the trigger condition. For instance, when a value of the 'measurement

reporting by trigger condition' bit is set to 1, the measurement result of the AP is reported only if the trigger condition for the reporting is met. When a value of the 'measurement reporting by trigger condition' bit is set to 1, despite that the trigger condition for the reporting is not met, if the AP is detected, the UE may report the measurement result of the AP. In doing so, the UE may report a measurement result of a preferred AP among the detected APs only to the eNB.

The UE may report the measurement result of the detected AP to the eNB. In this case, the measurement result of the AP may include at least one of a channel state information (e.g., RSSI (Received Signal Strength Indicator), RCPI (Received Channel Power Indicator), RSNI (Received Signal to Noise Indicator), etc.) and a preferred AP information.

For instance, Table 2 shows one example of a measurement result report message (Measurement Report message) sent to an eNB by a UE.

TABLE 2

1> set the measId to the measurement identity that triggered the measurement reporting;

1> set the measResultPCell to include the quantities of the PCell;

1> set the measResultServFreqList to include for each SCell that is configured, if any, within measResultSCell the quantities of the concerned SCell;

1> if the reportConfig associated with the measId that triggered the measurement reporting includes reportAddNeighMeas:

 2> for each serving frequency for which measObjectId is referenced in the measIdList, other than the frequency corresponding with the measId that triggered the measurement reporting:

 3> set the measResultServFreqList to include within measResultBestNeighCell the physCellId and the quantities of the best non-serving cell, based on RSRP, on the concerned serving frequency;

1> if there is at least one applicable neighbouring cell to report:

 2> set the measResultNeighCells to include the best neighbouring cells up to maxReportCells in accordance with the following:

 3> if the triggerType is set to event:

 4> include the cells included in the cellsTriggeredList as defined within the VarMeasReportList for this measId;

 3> else:

 4> include the applicable cells for which the new measurement results became available since the last periodical reporting or since the measurement was initiated or reset;

3> for each cell that is included in the measResultNeighCells, include the physCellId;

3> if the triggerType is set to event; or the purpose is set to reportStrongestCells or to reportStrongestCellsForSON:

 4> for each included cell, include the layer 3 filtered measured results in accordance with the reportConfig for this measId, ordered as follows:

 5> if the measObject associated with this measId concerns E-UTRA:

 6> set the measResult to include the quantity(ies) indicated in the reportQuantity within the concerned reportConfig in order of decreasing triggerQuantity, i.e. the best cell is included first;

 5> if the measObject associated with this measId concerns UTRA FDD and if ReportConfigInterRAT includes the reportQuantityUTRA-FDD:

 6> set the measResult to include the quantities indicated by the reportQuantityUTRA-FDD in order of decreasing measQuantityUTRA-FDD within the quantityConfig, i.e. the best cell is included first;

 5> if the measObject associated with this measId concerns UTRA FDD and if ReportConfigInterRAT does not include the reportQuantityUTRA-FDD; or

 5> if the measObject associated with this measId concerns UTRA TDD, GERAN or CDMA2000:

 6> set the measResult to the quantity as configured for the concerned RAT within the quantityConfig in order of either decreasing quantity for UTRA and GERAN or increasing quantity for CDMA2000 pilotStrength, i.e. the best cell is included first;

 5> if the measObject associated with this measId concerns WLAN and if ReportConfigInterRAT includes the reportQuantityWLAN:

 6> set the measResult to include the quantities indicated by the reportQuantityWLAN in order of decreasing measQuantityWLAN within the quantityConfig, i.e. the best cell is included first.

3> else if the purpose is set to reportCGI:

 4> if the mandatory present fields of the cgi-Info for the cell indicated by the cellForWhichToReportCGI in the associated measObject have been obtained:

 5> if the cell broadcasts a CSG identity:

 6> include the csg-Identity;

 6> include the csg-MemberStatus and set it to member if the cell is a CSG member cell;

5> if the si-RequestForHO is configured within the reportConfig associated with this measId:
6>include the cgi-Info containing all the fields that have been successfully acquired, except for the plmn-IdentityList;
5> else:
6>include the cgi-Info containing all the fields that have been successfully acquired;
1>if the ue-RxTxTimeDiffPeriodical is configured within the corresponding reportConfig for this measId;
2> set the ue-RxTxTimeDiffResult to the measurement result provided by lower layers;
2> set the currentSFN;
1> if the includeLocationInfo is configured in the corresponding reportConfig for this measId and detailed location information that has not been reported is available, set the content of the locationInfo as follows:
2> include the locationCoordinates;
2>if available, include the gnss-TOD-msec;
1> increment the numberOfReportsSent as defined within the VarMeasReportList for this measId by 1;
1> stop the periodical reporting timer, if running;
1> if the numberOfReportsSent as defined within the VarMeasReportList for this measId is less than the reportAmount as defined within the corresponding reportConfig for this measId:
2>start the periodical reporting timer with the value of reportInterval as defined within the corresponding reportConfig for this measId;
1> else:
2>if the triggerType is set to periodical:
3> remove the entry within the VarMeasReportList for this measId;
3> remove this measId from the measIdList within VarMeasConfig;
1> if the measured results are for CDMA2000 HRPD:
2> set the preRegistrationStatusHRPD to the UE's CDMA2000 upper layer's HRPD preRegistrationStatus;
1> if the measured results are for CDMA2000 1xRTT:
2> set the preRegistrationStatusHRPD to FALSE;
1> submit the MeasurementReport message to lower layers for transmission, upon which the procedure ends;

Referring to Table 2, if a measurement object for a random measurement ID is related to WLAN and a report-ConfigInterRAT message contains a WLAN report quantity (reportQuantityWLAN), a UE may set measResult including a quantity indicated by the reportQuantityWLAN in decreasing order of measQuantityWLAN within quantityConFIG. In doing so, the UE may control a best cell to be situated at a first place in the measResult. A parameter value for a trigger condition for reporting may be transmitted to the UE via reportConfigInterRAT message.

When a UE detects at least two APs, if an eNB receives a measurement result of the at least two APs, the eNB selects an AP appropriate for the UE from a plurality of APs and is then able to inform the UE of the selected AP. When the eNB selects the AP appropriate for the UE, at least one of the following metrics may be used.

- i) Same Operator: Preferentially select AP of the same operator of UE
- ii) UE's Priority: Preferentially select AP preferred by UE
- iii) Channel quality: Preferentially select AP having a good channel state
- iv) Load balancing: Select AP by considering load distribution
- v) Carried traffic: Select AP by considering traffic

The eNB may send indication, which indicates an AP to be accessed, to the UE using the above enumerated metrics.

Secondary System Management

As mentioned in the foregoing description with reference to FIG. 4 and FIG. 6, after the scanning of the secondary system, the secondary system management procedure is initiated for example. The secondary system management procedure may be mainly divided into a secondary system adding procedure, a secondary system deleting procedure and a secondary system changing procedure. Prior to the

description of each of the procedures, messages used for the secondary system shall be described as follows.

FIG. 11 is a flowchart to describe a message defined for a secondary system management procedure. Having detected a secondary system that meets a preset condition, a UE may send a message for requesting an association with an AP to an eNB [S1110]. This message may be named a SecondarySystemRequest message.

Having received the SecondarySystemRequest message from the UE, the eNB checks states of APs and is then able to select an AP that the UE will access [S1120]. Subsequently, in response to a request made by the UE, the eNB may send a message for indicating an access to a secondary system to the UE [S1130]. This message may be called a SecondarySystemSetup message. Information (e.g., identification information of the selected AP, authentication method with the selected AP, etc.) on an AP that the UE to be accessed, DRB (or flow) information to be transmitted to the secondary system, and the like may be included in the SecondarySystemSetup message. The UE transceives an association request frame, an association response frame and the like with the AP indicated by the SecondarySystemSetup message and is then able to attempt an access to the AP [S140]. In case that the secondary system corresponds to IEEE 802.11e, a traffic stream setup process (particularly, ADDTS request frame/ADDTS response frame transceiving) with the AP may be performed.

Thereafter, the UE may send a message for reporting a result of connection to the AP to the eNB [S1150]. This message may be named a SecondarySystemSetupComplete message. Through the SecondarySystemSetupComplete message, the UE may report a result of mapping between a DRB ID (or flow ID) of a DRB, which is to be transmitted to the secondary system, and AID/TSID (association ID/traffic stream ID).

If the AP is successfully accessed, the UE may transceive data for a specific traffic type via the AP. To this end, the eNB redirects a path of DL data for the specific flow to the AP and the UE is able to transmit UL data for the DRB ID (or flow ID) indicated by the eNB not to the eNB but to the AP. Data except the specific data type may be transceived via the eNB as it is.

Reassociation with the AP or Disassociation from the AP may be performed through the SecondarySystemSetup message and the SecondarySystemComplete message between the UE and the eNB. The reassociation with the AP means that the UE makes a handover into a neighbor AP. And, the disassociation from the AP means that the UE ends the access to the AP. In order to secure seamless data transmission of the UE, the eNB may support seamless flow mobility between the AP and the eNB or between APs.

For instance, although a UE has leaved a coverage of an AP, if there is no neighbor AP into which the UE will make a handover, in order to secure that the data transmitted via a secondary system may be transmitted seamlessly, an eNB may support seamless flow mobility between the AP and the eNB.

On the contrary, if the UE detects the neighbor AP to make a handover into, the UE may support seamless flow mobility between APs in order to secure that data for a specific flow may be transmitted seamlessly.

A primary system performs such a basic control operation as an access control between UE and AP, a configuration of DRB and the like. And a secondary system transceives data (i.e., data for a specific traffic type) indicated by the primary system. In particular, all data transmitted to a user equipment are configured by a radio resource configuration procedure of RRCConnectionReconfiguration transmitted to UE by eNB. And, data for a specific RB may be transmitted to the UE via AP under the determination made by the eNB. To this end, the eNB may redirect the data, which are transmitted to specific RNTI (radio network temporary identities) and specific DRB ID, among the data transmitted to the eNB to the AP.

Based on the above description, a secondary system adding procedure, a secondary system deleting procedure and a secondary system changing procedure are described in detail as follows.

Addition of Secondary System

FIG. 12 is a flowchart to describe an additional procedure of a secondary system. A secondary system adding procedure may be initiated by a UE or a base station. FIG. 12 shows one example that a secondary system adding procedure is initiated by a UE. Having detected a secondary system that meets a preset condition, a UE may request an association (connection setup) with the detected secondary system via SecondarySystemRequest message [S1210]. In doing so, one of the following conditions may be set as the preset condition. First of all, a UE-preferred AP is detected. Secondly, a measured signal strength of a AP is sufficiently high (e.g., a preferred AP is detected and a measurement result of the preferred AP is higher than a preset threshold, or a measurement result of AP is higher than a measurement result of eNB, etc). Thirdly, a specific flow (or DRB) has established.

Having received the SecondarySystemRequest message from the UE, the eNB may send a SecondarySystemSetup message indicating an access to the secondary system in response to the request made by the UE [S1220].

By skipping the SecondarySystemRequest message sending step S1210 and sending a SecondarySystemSetup message to the UE, the secondary system adding procedure may

be initiated (i.e., a method for a base station to initiate a secondary system adding procedure). In particular, if recognizing the establishment (i.e., DRB addition to UE) of a specific flow connection to the UE and the position of the UE located within an area of the secondary system, the eNB sends a SecondarySystemSetup message irrespective of a presence or non-presence of a reception of the SecondarySystemRequest message, thereby instructing the UE to access the secondary system [S1220].

In the SecondarySystemSetup message, at least one of information on the AP selected by the eNB, information on a flow (or DRB) to be transmitted to the secondary system, authentication information of the secondary system, information indicating whether to enter a doze mode after association, timer information, action time information and a data unit information to be redirected to an AP (e.g., U-plane, APN unit, DRB unit, flow unit, data unit in specific flow, etc) may be included.

The selected AP information may indicate an identification information of an AP that the UE will access. The flow (or DRB) information may indicate a traffic type of a flow that the UE will transceive via the AP. The UE attempts an access to the AP indicated by the selected AP information. If the access to the AP is successfully completed, the UE may transceive the traffic type indicated by the flow information via the selected AP.

The authentication information of the secondary system indicates a presence or non-presence of a shared key of the secondary system and the shared key. In case that the secondary system is an open system that does not use the shared key, the UE may access the secondary system without the shared key. On the other hand, if the secondary system is an encrypted system that uses the shared key, the UE may access the secondary system using the shared key indicated by the authentication information.

The information indicating whether to enter the doze mode indicates whether the UE should enter a power saving mode after the association with the secondary system. If the UE has no data to receive from the secondary system right now despite being associated with the secondary system, the eNB may instruct the UE to enter the doze mode after the association with the AP.

The timer information may indicate an expiry period until a timer for secondary system association starting after the transmission of the SecondarySystemSetup message expires.

The action time information may indicate a timing point for the UE to initiate the transceiving of data for a specific traffic type with the AP.

The data unit information may indicate a data unit (e.g., U-plane, APN, DRB, flow, flow in same flow) to be redirected to the AP. The data unit information may be an 1 bit indicator indicates whether the eNB retransmit all the flows to the AP. Or, the data unit information may indicate a data unit (i.e., U-plane, unit of APN, unit of DRB, unit of IP flow, unit of data in specific flow, etc) redirected to the AP. If the data unit information indicates that the data unit redirected to the AP is set as a unit of data in specific flow, ratio information indicates a ratio between amount of data in specific flow transmitted via the eNB and amount of data transmitted via the AP may further be included in the SecondarySystemSetup message.

In response to the reception of the SecondarySystemSetup message, the UE may send a SecondarySystemSetup ACK message [S1230]. Alternatively, the UE may attempt an access to the AP without sending the ACK message.

Having received the SecondarySystemSetup from the eNB, the UE may attempt the access to the AP [S1240]. In particular, the UE may attempt the access to the AP through the steps of synchronization, authentication and association with the AP.

The synchronization step is provided to match synchronization between the UE and the AP. By receiving a beacon frame from the AP, the UE may match the synchronization with the AP.

The authentication step includes the steps of transmitting an authentication request frame to the AP from the UE and transmitting an authentication response frame to the UE from the AP in response. In case that the AP is an open system, the authentication may be performed without utilizing a separate shared key. Otherwise, the authentication may be performed using a shared key.

After the UE has been successfully authenticated, the association step may be performed. In particular, the association step includes the steps of transmitting an association request frame to the AP from the UE and transmitting an association response message to the UE from the AP in response. In this case, AID (association ID) information on the UE may be included in the association response frame.

In case that the secondary system includes IEEE 802.11e system, the UE may perform a traffic stream (TS) setup. For the traffic stream setup, the UE receives an ADDTS request from the AP and is then able to transmit an ADDTS response to a specific AP in response to the request.

In order to report a result of the connection to the AP, the UE may send a SecondarySystemSetupComplete message [S1250]. The UE configures a SecondarySystemSetupComplete message to contain a status value indicating a success or failure in the access to the AP. Subsequently, the UE is always able to send the SecondarySystemSetupComplete message irrespective of the success or failure in the result of the connection to the AP. Alternatively, the UE may send the SecondarySystemSetupComplete message only if the access to the AP is successful.

For instance, if the SecondarySystemSetupComplete message contains the status value, the UE adjusts the status value to indicate whether the establishment of the connection to the AP is successful.

For another instance, only if the establishment of the connection to the AP is successful, the UE may send the SecondarySystemSetupComplete message. After the SecondarySystemSetupComplete message has been sent, if the SecondarySystemSetupComplete message is received within a prescribed time, the eNB may determine that the UE has successfully accessed the AP. On the contrary, after the SecondarySystemSetupComplete message has been sent, if the SecondarySystemSetupComplete message is not received within the prescribed time, the eNB may determine that the UE has not accessed the AP successfully.

After sending a SecondarySystemSetup message, the eNB may start a secondary system association timer. If not receiving the SecondarySystemSetupComplete message until the expiration of the secondary system association timer, the eNB may determine that the UE fails in the access to the AP. Using the timer information of the SecondarySystemSetup message, the UE may recognize an expiry timing point of the secondary system association timer. In order to secure a time enough for the UE to send the SecondarySystemSetupComplete message, the expiry period of the secondary system association timer may be determined in consideration of a time taken for the association between the UE and the AP.

The SecondarySystemSetupComplete message may contain information on an address (e.g., IP address assigned to the UE by the AP) assigned to the UE by the AP.

If the establishment of the connection to the AP is not successful, the eNB newly selects an AP and may be then able to resend a SecondarySystemSetup message to the newly selected AP in order to indicate an access to the newly selected AP. Having received the re-sent SecondarySystemSetup message, the UE may attempt the access to the newly selected AP indicated by the re-received SecondarySystemSetup message.

If the establishment of the connection to the AP is successful, the UE may transceive data for a specific traffic type via the AP and is able to transceive data for other traffic types via the eNB [S1260]. The traffic type to be transceived via the AP may be indicated by DRB information (or flow information) of the SecondarySystemSetup message. In order for downlink data of the specific traffic type to be transmitted via the AP, the eNB may redirect the downlink data for the specific traffic type to the AP. To this end, the eNB may set a destination of the data for the specific data type to an address (e.g., IP address assigned to the UE by the AP) of the UE. The UE may transmit uplink data for the specific traffic type to the AP. eNB (or interworking entity) may redirect a downlink data to UE by transmitting a specific message to an entity which manages IP information on a flow of UE (e.g., P-GW or terminal end). The specific message may be a flow IP address binding update message which comprises an action time information. Action time information included in the flow IP address binding update message may be same as an action time message included in SecondarySystemSetup messages transmitted from the eNB to UE. In this case, the eNB (or an interworking entity) may redirect a downlink data to an AP by transmitting a specific message to a main entity (e.g., P-GW or a UE situating at an end) managing IP information on a flow of the UE. In this case, the transmitted specific message may correspond to a Flow-IP address binding update message and action time information may be included in the message. The action time information included in the Flow-IP address binding update message and action time information of a SecondarySystemSetup message, which is transmitted to the UE by the eNB, may indicate identical timing.

In doing so, the eNB may designate an action time that is a timing point at which the UE starts the transceiving of the data for the specific traffic type via the AP. Even if the establishment of the connection to the AP is successful, the UE may not perform the transceiving of the data for the specific traffic type via the AP until an action time comes. If the SecondarySystemSetup message is lost, the eNB is unable to recognize whether the UE has been successfully accessed the AP. Nonetheless, if the UE intends to transceive the data for the specific traffic type via the AP, since the eNB is unable to change or redirect the path of the data for the specific traffic type to the AP, the UE may have a problem in receiving the downlink data for the specific traffic type appropriately.

Hence, the eNB designates the action time. The eNB is then able to control the UE to start the transceiving for the specific traffic type with the AP only if the action time expires. In this case, the action time may be calculated in consideration of the expiry period of the secondary system association timer and a time taken for the retransmission of the SecondarySystemSetup message due to the failure in accessing the AP. In particular, after the SecondarySystemSetup message has been sent, the action time may be set to a time after elapse of a time equal to or greater than a sum

of the expiry period of the secondary system association timer and the time taken for the transmission of the SecondarySystemSetup message.

Change of Secondary System

FIG. 13 is a flowchart to describe a changing procedure of a secondary system. If a UE leaves a coverage of an accessed AP or an AP having a measurement higher than that of the accessed AP is detected, an eNB may instruct the UE to make a handover into a new AP. For clarity of the following description, an AP currently providing a service to the UE shall be named a serving AP or an old AP and a new AP becoming a handover target shall be named a target AP or a new AP. In order to instruct the UE to make a handover into a new AP, the eNB may send a SecondarySystemSetup message to the UE [S1310]. The SecondarySystemSetup message sent to the UE may include at least one of an information on a target AP, an information on a flow (or DRB) to be transmitted via a secondary system, an authentication information of the secondary system, an information indicating whether to enter a doze mode after association, a timer information, a disconnection time information, an action time information and a data unit information to be redirected to an AP (U-plane, APN, DRB, flow, data in same flow).

The target AP information may indicate an identification information of a new AP that the UE will newly access. And, the flow (or DRB) information may indicate a traffic type of a flow to be transceived by the UE via the new AP. The authentication information of the secondary system may indicate a presence or non-presence of a shared key of the new AP and the shared key. The information indicating whether to enter the doze mode may indicate whether the UE should enter a power saving mode after the association with the new AP. The timer information may indicate an expiry period until expiration of a secondary system reassociation timer after sending the SecondarySystemSetup message. The disconnection time information may indicate a timing point at which the UE is disassociated from the old AP. Or, the disconnection time information may indicate a timing point at which the eNB stops redirecting data for specific flow to the old AP. The action time information may indicate a timing point at which the UE may start the transeiving of data for a specific traffic with the new AP. Or, the Action information may indicate a timing point at which the eNB redirects data for specific flow which stopped redirecting at the timing point indicated by the disconnection time information to the new AP. The data unit information may indicate a data unit (e.g., U-plane, APN, DRB, flow, flow in same flow) to be redirected to the AP.

eNB may transmit a Flow-IP address binding update message which comprises a disconnection time information and an action time information to an entity which manages IP information on a flow of UE (e.g., P-GW or terminal end) in course of (or after) transmitting the SecondarySystemSetup message. The entity which received the Flow-IP address binding update message (e.g., P-GW) may newly set an IP address of data on a specific flow to be transmitted to UE based on the disconnection time information and the action time information.

While the reassociation procedure of the UE is in progress through a control connection (e.g., a backhaul control connection, a radio control connection, etc.) between the old AP and the new AP, the eNB may transmit a security information set by the old AP to the new AP.

In response to the reception of the SecondarySystemSetup message, the UE sends a SecondarySystemSetup ACK mes-

sage [S1320] or may disconnect the access from the old AP without sending the ACK message.

Having received the SecondarySystemSetup message, the UE may disconnect the connection from the old AP [S1330]. In doing so, the UE may disconnect the connection from the old AP at the disconnection timing point indicated by the disconnection time information. Once the disconnection timing point is designated through the disconnection time information, the eNB may accurately obtain the timing point of the disconnection between the UE and the old AP. Hence, the eNB may accurately calculate the timing point of terminating the redirection of the data for the specific traffic type to the old AP.

At the disassociation timing point, the UE may send a disassociation notification message to the old AP. If an ACK message for the disassociation notification message is received from the old AP, the connection between the UE and the old AP may be terminated.

Once the connection to the old AP is terminated, the UE may attempt an access to a new AP [S1340]. In particular, the UE may be able to attempt the access to the new AP through synchronization, authentication and association with the new AP.

In order to report a result of the connection to the new AP, the UE may send a SecondarySystemSetupComplete message [S1350]. The UE configures a SecondarySystemSetupComplete message to contain a status value indicating a success or failure in the access to the new AP. Subsequently, the UE is always able to send the SecondarySystemSetupComplete message irrespective of the success or failure in the result of the connection to the new AP. Alternatively, the UE may send the SecondarySystemSetupComplete message only if the access to the new AP is successful.

For instance, if the SecondarySystemSetupComplete message contains the status value, the UE adjusts the status value to indicate whether the establishment of the connection to the new AP is successful.

For another instance, only if the establishment of the connection to the new AP is successful, the UE may send the SecondarySystemSetupComplete message.

The eNB waits for the SecondarySystemSetupComplete message to be sent from the UE for a while. If the eNB receives the SecondarySystemSetupComplete message, the eNB determines that the UE has succeeded in the access to the AP. On the contrary, after the SecondarySystemSetupComplete message has been sent, if the SecondarySystemSetupComplete message is not received within a prescribed time, the eNB may determine that the UE has failed in the access to the AP. After sending a SecondarySystemSetup message, the eNB may start a secondary system reassociation timer. If not receiving the SecondarySystemSetupComplete message until the expiration of the secondary system reassociation timer, the eNB may determine that the UE fails in the access to the new AP. In order to secure a time enough for the UE to send the SecondarySystemSetupComplete message, the expiry period of the secondary system reassociation timer may be determined in consideration of a time taken for the reassociation with the AP.

The SecondarySystemSetupComplete message may contain information on an address (e.g., IP address assigned to the UE by the AP) assigned to the UE by the new AP.

If the establishment of the connection to the new AP is not successful, the eNB newly selects a target AP and may be then able to resend a SecondarySystemSetup message to indicate an access to the newly selected target AP. Having received the re-sent SecondarySystemSetup message, the

UE may attempt the access to the newly selected target AP indicated by the re-received SecondarySystemSetup message.

If the establishment of the connection to the AP is successful, the UE may transceive data for a specific traffic type not via the old AP but via the new AP [S1360]. The traffic type to be transceived via the new AP may be indicated by DRB information (or flow information) of the SecondarySystemSetup message. And, data other than the specific traffic type may be transceived via the eNB as they are.

As mentioned in the foregoing description with reference to FIG. 11, the eNB may designate an action time for the UE to initiate the transceiving of the data for the specific data type via the new AP [not shown in the drawing]. Once the action time is designated, the UE may initiate the transceiving for the specific traffic type with the new AP only if the action time is up.

Deletion of Secondary System

FIGS. 14A to 14C are flowcharts to describe a deleting procedure of a secondary system. FIG. 14A and FIG. 14B are diagrams for examples that a UE is disassociated from an AP by an indication of an eNB. FIG. 14C is a diagram for one example that a UE is actively disassociated from an AP.

Referring to FIG. 14A and FIG. 14B, an eNB may send a UE a SecondarySystemSetup message to indicate disassociation from an AP [S1410a, S1410b]. The SecondarySystemSetup message may include at least one of an information on a disassociated AP, an information on a flow (or DRB) transmitted from the disassociated AP, a disconnection time information, an action time information and a timer information.

The disassociated AP information may indicate an identification information of an AP from which the UE will be disconnected. And, the flow (or DRB) information may indicate a traffic type of a flow handled by the AP to be disconnected.

The timer information may indicate an expiry period until expiration of a secondary system disassociation timer that starts after sending the SecondarySystemSetup message.

The disconnection time information may indicate a timing point at which the UE is disassociated from the AP. And, the action time information may indicate a timing point at which the UE may start the transceiving of data for a specific traffic with the eNB.

In response to the reception of the SecondarySystemSetup message, the UE sends a SecondarySystemSetup ACK message [S1420a, 1420b] or may disconnect the access from the AP without sending the ACK message.

Having received the SecondarySystemSetup message, the UE may terminate the access from the AP [S1430a, 1430b]. In doing so, the UE may disconnect the connection from the AP at the disconnection time indicated by the disconnection time information. Once the disconnection time is designated through the disconnection time information, the eNB may accurately obtain the timing point of the disconnection between the UE and the AP. Hence, the eNB may accurately calculate the timing point of terminating the redirection of the data for the specific traffic type to the AP.

At the disassociation timing point, the UE may send a disassociation notification message to the AP. If an ACK message for the disassociation notification message is received from the AP, the connection between the UE and the AP may be terminated.

Once the connection to the AP is terminated, in order to report that the connection to the AP has been successfully terminated, the UE may send a SecondarySystemSetupCom-

plete message [S1440a]. The UE configures a SecondarySystemSetupComplete message to contain a status value indicating a success or failure in the termination of the connection to the AP. Subsequently, the UE is always able to send the SecondarySystemSetupComplete message irrespective of the success or failure in the result of the termination of the connection to the AP. Alternatively, the UE may send the SecondarySystemSetupComplete message only if the termination of the connection to the AP is successfully completed.

For instance, if the SecondarySystemSetupComplete message contains the status value, the UE adjusts the status value to indicate whether the connection to the AP is successfully terminated.

For another instance, only if the connection to the AP is successfully terminated, the UE may send the SecondarySystemSetupComplete message.

The eNB waits for the SecondarySystemSetupComplete message to be sent from the UE for a while. If the eNB receives the SecondarySystemSetupComplete message, the eNB determines that the UE has succeeded in the termination of the connection to the AP. On the contrary, after the SecondarySystemSetupComplete message has been sent, if the SecondarySystemSetupComplete message is not received within a prescribed time, the eNB may determine that the UE has failed in the termination of the connection to the AP. After sending the SecondarySystemSetup message, the eNB may start a secondary system disassociation timer. If not receiving the SecondarySystemSetupComplete message until the expiration of the secondary system disassociation timer, the eNB may determine that the UE fails in the termination of the connection between the UE and the AP. In order to secure a time enough for the UE to send the SecondarySystemSetupComplete message, the expiry period of the secondary system disassociation timer may be determined in consideration of a time taken for the disassociation from the AP. If determining that the connection between the UE and the AP is not successfully terminated, the eNB may resend the UE the SecondarySystemSetup message indicating the termination of the connection to the AP.

Having sent the SecondarySystemSetupComplete message, the UE may transceive data for a specific traffic type, which was transceived via the AP, via the eNB [S1450a]. In doing so, the UE may initiate the transceiving of the data for a traffic type of a specific flow at the action time indicated by the eNB.

For another instance, if the connection to the AP is terminated, the UE may initiate the transceiving of the data for the traffic type of the specific flow via the eNB immediately [S1440b]. The step of sending the SecondarySystemSetupComplete message for reporting a result of the termination of the connection to the AP may be skipped or the SecondarySystemSetupComplete message may be sent after initiation of the transceiving of the data for the traffic type of the specific flow with the eNB [S1450b].

Referring to FIG. 14C, irrespective of the reception of the SecondarySystemSetup message from the eNB, the UE may terminate the connection to the AP by itself [S1410c]. Once the connection to the AP is terminated, the UE may send a SecondarySystemSetupComplete message to indicate that the connection to the AP has been successfully terminated [S1420c]. In particular, despite that a request for sending the SecondarySystemSetupComplete message is not made, the UE may send the SecondarySystemSetupComplete message to the eNB [unsolicited].

31

Having received the SecondarySystemSetupComplete message from the UE, the eNB stops redirection to the AP and may transmit the data for the traffic type of the specific flow to the UE in direct.

According to various embodiments of the present invention, a UE supporting both cellular and WLAN may efficiently select a heterogeneous network for a flow via a control of a cellular network in a wideband wireless communication system.

The above-described embodiments may correspond to combinations of elements and features of the present invention in prescribed forms. And, it may be able to consider that the respective elements or features may be selective unless they are explicitly mentioned. Each of the elements or features may be implemented in a form failing to be combined with other elements or features. Moreover, it may be able to implement an embodiment of the present invention by combining elements and/or features together in part. A sequence of operations explained for each embodiment of the present invention may be modified. Some configurations or features of one embodiment may be included in another embodiment or may be substituted for corresponding configurations or features of another embodiment. And, it is apparently understandable that a new embodiment may be configured by combining claims failing to have relation of explicit citation in the appended claims together or may be included as new claims by amendment after filing an application.

While the present invention has been described and illustrated herein with reference to the preferred embodiments thereof, it will be apparent to those skilled in the art that various modifications and variations can be made therein without departing from the spirit and scope of the invention. Thus, it is intended that the present invention covers the modifications and variations of this invention that come within the scope of the appended claims and their equivalents.

What is claimed is:

1. A method of supporting signal transmission and reception using two or more radio access technologies (RATs), which is performed by a user equipment, the method comprising:

receiving a RRCconnectionReconfiguration message from an eNode B, the RRCconnectionReconfiguration message initiating the user equipment to perform WLAN measurements;

performing the WLAN measurements according to the RRCconnectionReconfiguration message;

transmitting a measurement report to the eNode B when a predefined measurement report trigger condition is satisfied;

receiving, from the eNode B, a first message, the first message including:

an added data radio bearer identity (added DRB ID); and

information regarding at least one access point (AP), wherein the at least one AP is configured by the eNode B based on the measurement report, and

wherein the added DRB ID is configured dedicatedly for data communication with the at least one AP; and

transmitting first data associated with the added DRB ID to an AP of the at least one AP and second data associated with a DRB ID different than the added DRB ID to the eNode B.

32

2. The method of claim 1, further comprising: performing an association with the AP.

3. The method of claim 1, wherein the first message comprises action time information indicating a time of communicating with the AP and wherein the user equipment begins to transceive data with the AP on a time indicated by the action time information.

4. The method of claim 1, wherein the second message comprises an address value assigned to the user equipment by the AP.

5. The method of claim 1, wherein the predefined measurement report trigger condition is satisfied when a WLAN measurement result is better than a threshold.

6. The method of claim 1, wherein the first message further comprises unit information indicating a unit of data to be switched to the AP.

7. A user equipment supporting signal transmission and reception using two or more radio access technologies (RATs), the user equipment comprising:

a communication unit; and

a processor that:

controls the communication unit to receive a RRCconnectionReconfiguration message, from an eNode B, the RRCconnectionReconfiguration initiating the user equipment to perform WLAN measurements;

performs the WLAN measurements according to the RRCconnectionReconfiguration message;

controls the communication unit to transmit a measurement report to the eNode B when a predefined measurement report trigger condition is satisfied; and

controls the communication unit to receive, from the eNode B, a first message, the first message including: an added data radio bearer identity (added DRB ID), and

information regarding at least one access point (AP), wherein the at least one AP is configured by the eNode B based on the measurement report,

wherein the added DRB ID is configured dedicatedly for data communication with the at least one AP, and

wherein the processor further controls the communication unit to simultaneously transmit first data associated with the added DRB ID to an AP of the at least one AP and second data associated with a DRB ID different than the added DRB ID to the eNode B.

8. The user equipment of claim 7, wherein the processor further performs an association with the AP.

9. The user equipment of claim 7, wherein the first message comprises action time information indicating a time of communicating with the AP and wherein the user equipment begins to transceive data with the AP at a time indicated by the action time information.

10. The user equipment of claim 7, wherein the second message comprises an address value assigned to the user equipment by the AP.

11. The user equipment of claim 7, wherein the predefined measurement report trigger condition is satisfied when a WLAN measurement result is better than a threshold.

12. The user equipment of claim 7, wherein the first message further comprises unit information indicating a unit of data to be switched to the AP.

* * * * *