



US009613246B1

(12) **United States Patent**  
**Gozzini et al.**

(10) **Patent No.:** **US 9,613,246 B1**  
(45) **Date of Patent:** **Apr. 4, 2017**

(54) **MULTIPLE SCAN ELEMENT ARRAY  
ULTRASONIC BIOMETRIC SCANNER**

(71) Applicant: **Apple Inc.**, Cupertino, CA (US)

(72) Inventors: **Giovanni Gozzini**, Cupertino, CA (US);  
**Matthew E. Last**, Cupertino, CA (US);  
**Brian Michael King**, Cupertino, CA  
(US); **Marduke Yousefpor**, Cupertino,  
CA (US)

(73) Assignee: **Apple Inc.**, Cupertino, CA (US)

(\* ) Notice: Subject to any disclaimer, the term of this  
patent is extended or adjusted under 35  
U.S.C. 154(b) by 276 days.

5,719,950 A	2/1998	Osten	
6,091,406 A	7/2000	Kambara	
6,159,149 A	12/2000	Erikson	
6,720,712 B2	4/2004	Scott	
7,400,750 B2 *	7/2008	Nam	..... G06K 9/0002 382/124
7,458,268 B2	12/2008	Schneider et al.	
7,497,120 B2	3/2009	Schneider et al.	
7,568,391 B2	8/2009	Schneider et al.	
7,656,932 B2	2/2010	Durand	
7,667,374 B2	2/2010	Aono et al.	
7,734,435 B2	6/2010	Thomas et al.	
7,739,912 B2	6/2010	Schneider et al.	
7,770,456 B2	8/2010	Stevenson et al.	
8,047,995 B2	11/2011	Wakabayashi et al.	
8,085,998 B2	12/2011	Setlak et al.	
8,095,328 B2	1/2012	Thomas et al.	

(Continued)

(21) Appl. No.: **14/487,253**

(22) Filed: **Sep. 16, 2014**

(51) **Int. Cl.**  
**H01L 41/22** (2013.01)  
**G06K 9/00** (2006.01)  
**H01L 41/25** (2013.01)

(52) **U.S. Cl.**  
CPC ..... **G06K 9/0002** (2013.01); **H01L 41/25**  
(2013.01)

(58) **Field of Classification Search**  
CPC ..... G01N 29/2437; H01L 41/22  
USPC ..... 73/625, 626, 628, 641, 632, 633;  
310/322, 334  
See application file for complete search history.

(56) **References Cited**

**U.S. PATENT DOCUMENTS**

4,729,128 A *	3/1988	Grimes	..... G01S 15/89 235/380
5,162,618 A	11/1992	Knowles	
5,515,298 A	5/1996	Biez	
5,589,636 A	12/1996	Biez	

**FOREIGN PATENT DOCUMENTS**

WO WO 94/02911 2/1994

*Primary Examiner* — Michael A Lyons

*Assistant Examiner* — Suman K Nath

(74) *Attorney, Agent, or Firm* — Brownstein Hyatt Farber  
Schreck, LLP

(57) **ABSTRACT**

An ultrasonic biometric scanner includes an ultrasonic multiple scan element array with multiple scan elements. The array includes piezoelectric material such as lead zirconate titanate or polyvinylidene difluoride with a first electrode on a first surface and a second electrode on a second, opposite surface. At least one of the first electrode or the second electrode include multiple electrodes wherein the number of the multiple electrodes corresponds to a number of the multiple scan elements. A substrate is electrically coupled to the second electrode and/or the first electrode. A cover may be positioned over the first electrode. The cover has an acoustic impedance matching ultrasonic signals emitted by the piezoelectric material.

**20 Claims, 6 Drawing Sheets**

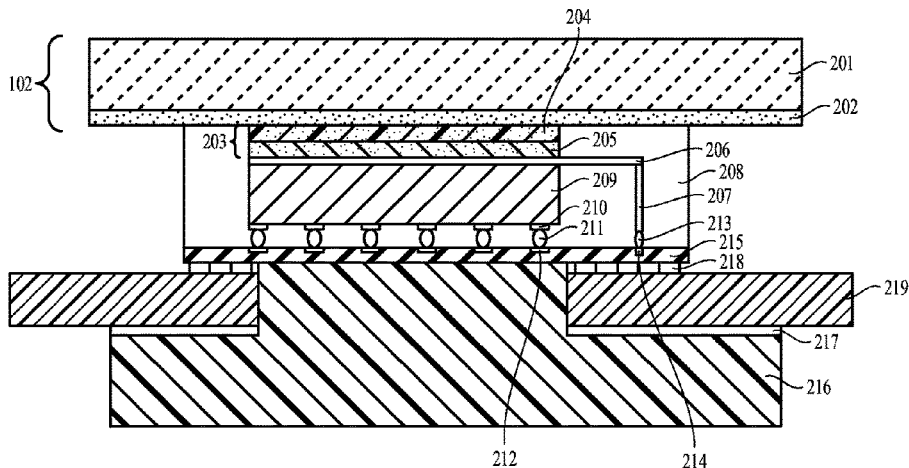

(56)

References Cited

U.S. PATENT DOCUMENTS

8,201,739	B2 *	6/2012	Schneider .....	G06K 9/0002 235/439	2008/0157940	A1 *	7/2008	Breed .....	B60C 11/24 340/425.5
8,335,356	B2	12/2012	Schmitt		2009/0167704	A1	7/2009	Terlizzi et al.	
8,601,876	B2	12/2013	Schneider et al.		2010/0265663	A1 *	10/2010	Yamashita .....	H01L 23/552 361/715
8,617,078	B2	12/2013	Machida et al.		2011/0056737	A1 *	3/2011	Hagiwara .....	H01G 2/10 174/260
8,666,126	B2	3/2014	Lee et al.		2011/0071397	A1 *	3/2011	Wodnicki .....	B06B 1/0629 600/459
8,724,869	B2	5/2014	Schneider et al.		2011/0163630	A1 *	7/2011	Klootwijk .....	B06B 1/0292 310/300
8,781,180	B2	7/2014	Schneider et al.		2012/0092026	A1	4/2012	Liautaud et al.	
8,791,792	B2	7/2014	Benkley, III		2013/0015868	A1	1/2013	Peng	
8,982,089	B2	3/2015	Lim		2013/0201134	A1 *	8/2013	Schneider .....	G06F 3/041 345/173
9,044,171	B2	6/2015	Venkatraman et al.		2014/0333328	A1	11/2014	Nelson et al.	
9,056,082	B2	6/2015	Liautaud et al.		2014/0352440	A1 *	12/2014	Fennell .....	G01N 29/22 73/632
9,100,034	B2	8/2015	Oshima		2014/0354596	A1 *	12/2014	Djordjev .....	G06K 9/0002 345/175
9,170,668	B2	10/2015	Schneider et al.		2014/0359757	A1	12/2014	Sezan et al.	
2003/0102777	A1 *	6/2003	Kuniyasu .....	B06B 1/0629 310/334	2015/0053006	A1	2/2015	DeCoux et al.	
2003/0109993	A1	6/2003	Peat et al.		2015/0189136	A1	7/2015	Chung et al.	
2004/0140735	A1	7/2004	Scott et al.		2015/0192547	A1	7/2015	Lee et al.	
2005/0193823	A1 *	9/2005	Amano .....	G06K 9/0002 73/704	2015/0358740	A1 *	12/2015	Tsai .....	G01N 29/36 73/632
2006/0196271	A1	9/2006	Jancsik et al.		2016/0063300	A1	3/2016	Du et al.	
2008/0142571	A1 *	6/2008	Yokozuka .....	H05K 1/144 228/110.1					

\* cited by examiner

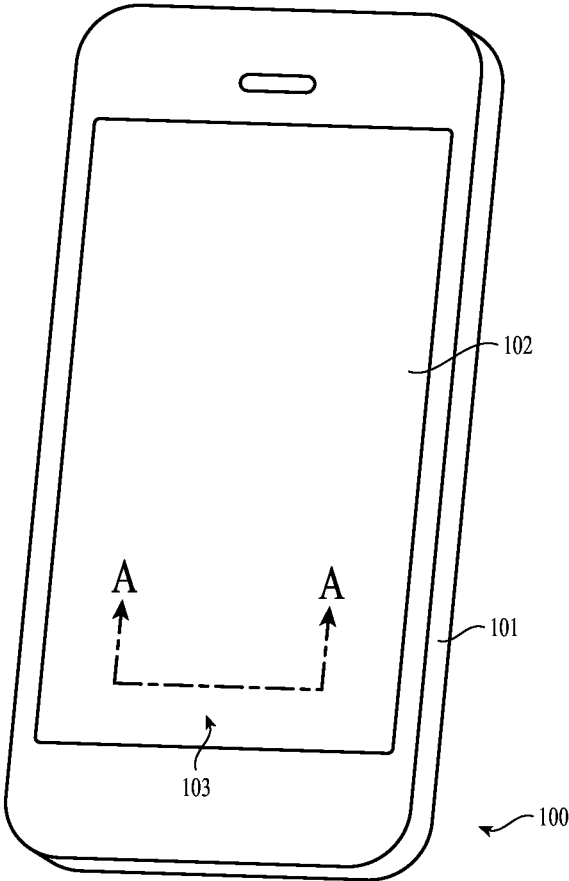

FIG. 1

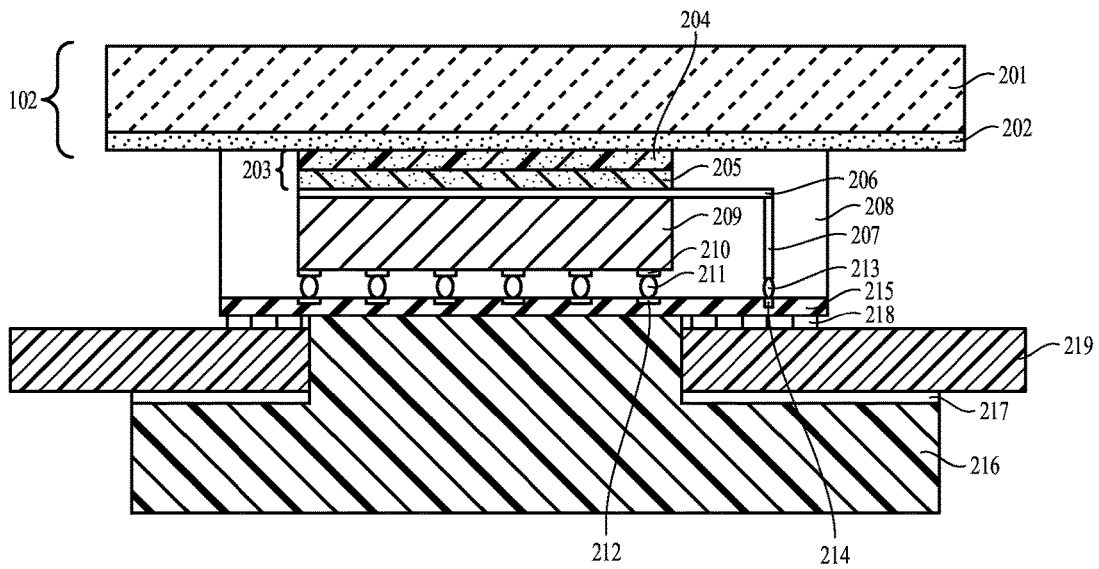

FIG. 2



FIG. 3A

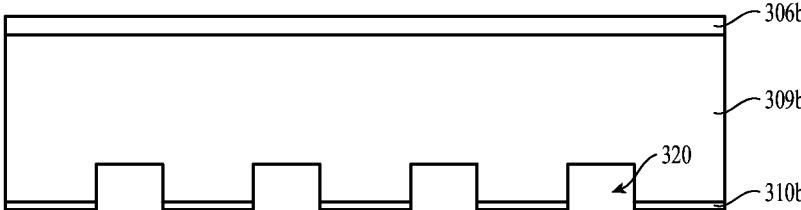

FIG. 3B

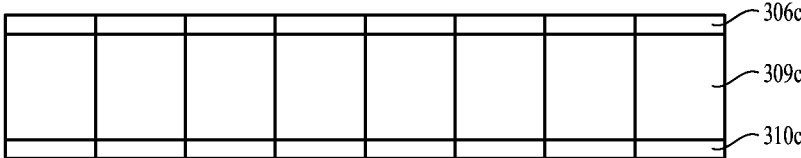

FIG. 3C

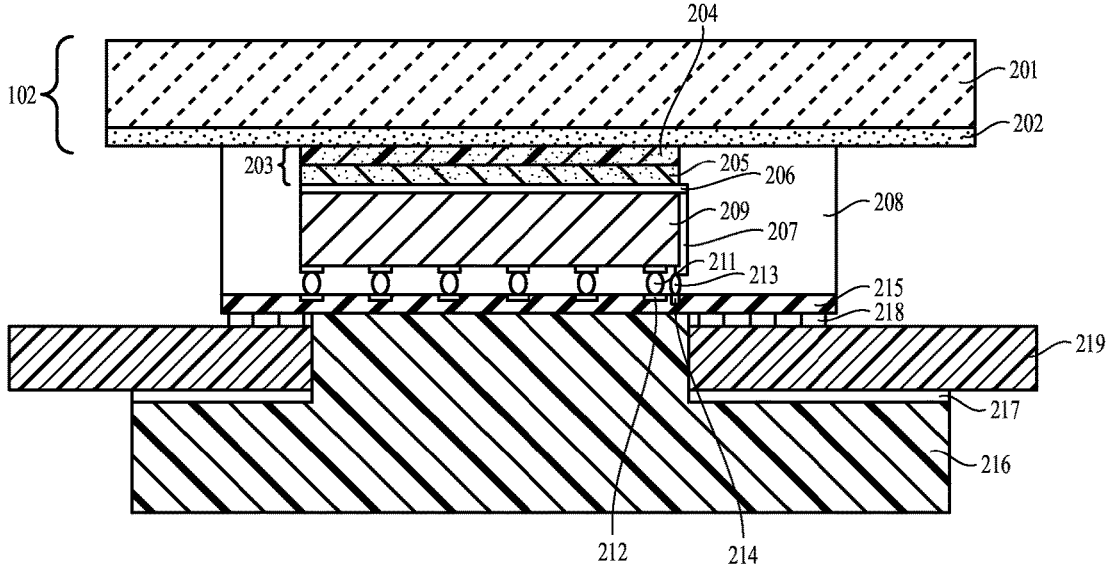

FIG. 4

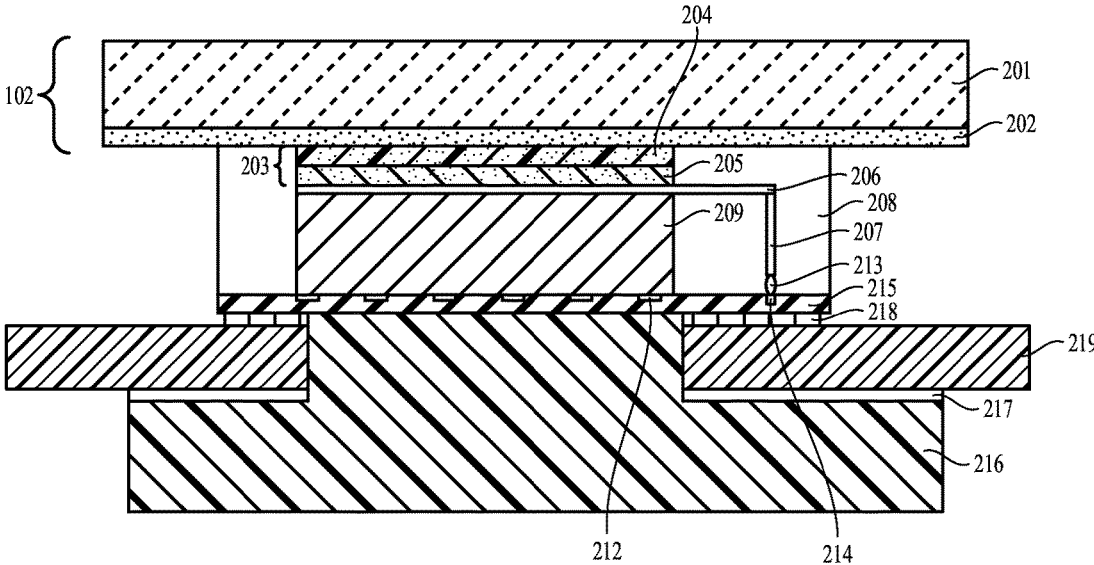
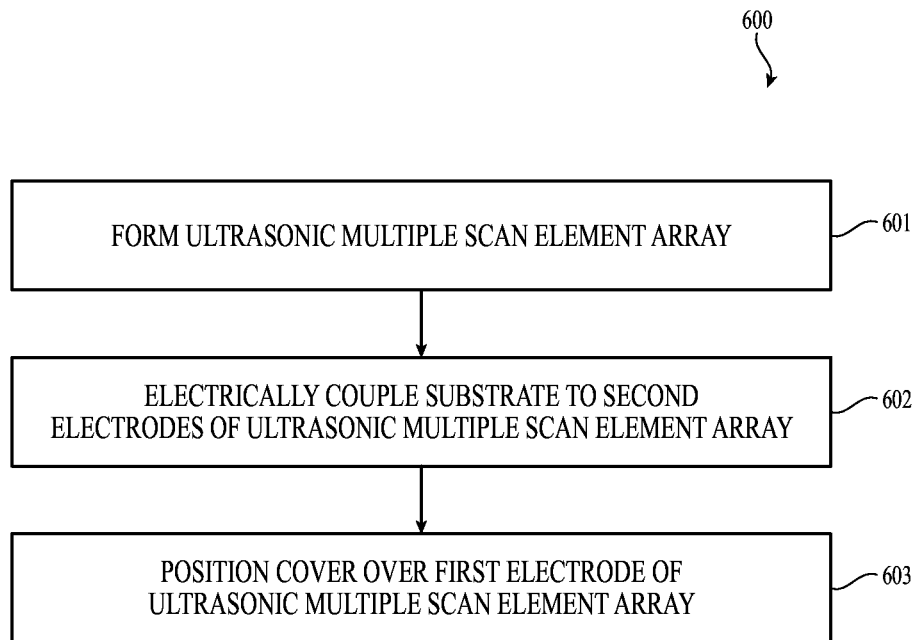

FIG. 5



**FIG. 6**



1

## MULTIPLE SCAN ELEMENT ARRAY ULTRASONIC BIOMETRIC SCANNER

### TECHNICAL FIELD

This disclosure relates generally to biometrics, and more specifically to a multiple scan element array ultrasonic biometric scanner.

### BACKGROUND

Biometrics refers to metrics related to user characteristics and traits. Biometric scans, such as fingerprint or palm print scans, are sometimes used to identify and/or authenticate users. For example, an electronic device may be associated with a particular user and the electronic device may verify that a current user is the particular user in order to allow operation by obtaining and analyzing the current user's fingerprint.

A biometric scanner such as a fingerprint scanner may be used to obtain a user's biometric information. For example, a biometric scanner such as a fingerprint or palm print scanner may capture one or more images of a user's fingertip, palm, or other body part and interpret the image(s) to create a map of the ridges and valleys of the user's fingerprint, palm, or other body part. Such a map may then be compared to stored information in an attempt to authenticate the user.

### SUMMARY

The present disclosure discloses apparatuses, systems, and methods related to multiple scan element array ultrasonic biometric scanners. An ultrasonic biometric scanner may include an ultrasonic multiple scan element array with multiple scan elements having piezoelectric material (such as lead zirconate titanate or polyvinylidene difluoride) with a first electrode on a first surface and a second electrode on a second, opposite surface. At least one of the first electrode or the second electrode include multiple electrodes wherein the number of the multiple electrodes corresponds to a number of the multiple scan elements. In some implementations, notches in the first or second surfaces may separate the multiple electrodes and/or the piezoelectric material may be a number of separate piezoelectric elements. A substrate may be electrically coupled to the second electrode and/or the first electrode and a cover may be positioned over the first electrode. The cover may have an acoustic impedance matching ultrasonic signals emitted by the piezoelectric material. As such, the ultrasonic biometric scanner may be capable of obtaining more accurate biometric scans, such as fingerprint scans, than non-multiple scan element ultrasonic biometric scanners while being capable of occupying a smaller space.

In various embodiments, an ultrasonic biometric scanner may include an ultrasonic multiple scan element array having multiple scan elements. The ultrasonic multiple scan element array may include piezoelectric material having a first surface and a second surface opposing the first surface; a first electrode positioned on the first surface; and a second electrode positioned on the second surface. At least one of the first electrode or the second electrode may include multiple electrodes wherein the number of the multiple electrodes corresponds to a number of the multiple scan elements. The ultrasonic biometric scanner may further include a substrate electrically coupled to the second electrode and a cover positioned over the first electrode. The

2

ultrasonic biometric scanner may be operable to obtain a biometric scan of a body part via the cover by causing the piezoelectric material to emit an ultrasonic signal. The cover may have an acoustic impedance matching the ultrasonic signal.

In some embodiments, an electronic device may have an exterior surface having an interior portion and an exterior portion and an ultrasonic biometric scanner. The ultrasonic biometric scanner may include an ultrasonic multiple scan element array having multiple scan elements that includes piezoelectric material having a first surface and a second surface opposing the first surface; a first electrode positioned on the first surface; and a second electrode positioned on the second surface. At least one of the first electrode or the second electrode may include multiple electrodes wherein the number of the multiple electrodes corresponds to a number of the multiple scan elements. The ultrasonic biometric scanner may also include a substrate electrically coupled to the second electrode and a cover positioned over the first electrode, the cover coupled to the interior portion of the exterior surface. The ultrasonic biometric scanner may be operable to obtain a biometric scan of a body part via the exterior surface by causing the piezoelectric material to emit an ultrasonic signal. The cover may have an acoustic impedance matching the ultrasonic signal. The exterior surface may have an acoustic impedance matching the ultrasonic signal.

In one or more embodiments, a method for assembling an ultrasonic biometric scanner may include: forming an ultrasonic multiple scan element array including multiple scan elements by positioning a first electrode on a first surface of piezoelectric material and a second electrode on a second surface of the piezoelectric material opposing the first surface, at least one of the first electrode or the second electrode include multiple electrodes wherein the number of the multiple electrodes corresponds to a number of the multiple scan elements; electrically coupling a substrate to the number of second electrodes; and positioning a cover over the first electrode, the cover having an acoustic impedance matching an ultrasonic signal the piezoelectric material is operable to emit to obtain a biometric scan of a body part via the cover.

It is to be understood that both the foregoing general description and the following detailed description are for purposes of example and explanation and do not necessarily limit the present disclosure. The accompanying drawings, which are incorporated in and constitute a part of the specification, illustrate subject matter of the disclosure. Together, the descriptions and the drawings serve to explain the principles of the disclosure.

### BRIEF DESCRIPTION OF THE DRAWINGS

FIG. 1 is an isometric view of an example system for biometric scanning using a multiple scan element array ultrasonic biometric scanner.

FIG. 2 is a cross sectional view of a first example ultrasonic biometric scanner that may be used in the example system of FIG. 1 taken along the line A-A of FIG. 1.

FIG. 3A is a first example of an ultrasonic multiple scan element array that may be utilized in the example ultrasonic biometric scanner of FIG. 2.

FIG. 3B is a second example of an ultrasonic multiple scan element array that may be utilized in the example ultrasonic biometric scanner of FIG. 2.

3

FIG. 3C is a third example of an ultrasonic multiple scan element array that may be utilized in the example ultrasonic biometric scanner of FIG. 2.

FIG. 4 is a cross sectional view of a second example ultrasonic biometric scanner that may be used in the example system of FIG. 1 taken along the line A-A of FIG. 1.

FIG. 5 is a cross sectional view of a third example ultrasonic biometric scanner that may be used in the example system of FIG. 1 taken along the line A-A of FIG. 1.

FIG. 6 is a method diagram illustrating an example method for assembling an ultrasonic biometric scanner. This method may assemble the example systems of FIGS. 1-5.

#### DETAILED DESCRIPTION

The description that follows includes sample apparatuses, systems, and methods that embody various elements of the present disclosure. However, it should be understood that the described disclosure may be practiced in a variety of forms in addition to those described herein.

The present disclosure discloses apparatuses, systems, and methods related to multiple scan element array ultrasonic biometric scanners. An ultrasonic biometric scanner may include an ultrasonic multiple scan element array with multiple scan elements having piezoelectric material with a first electrode on a first surface and a second electrode on a second, opposite surface. At least one of the first electrode or the second electrode may include multiple electrodes wherein the number of the multiple electrodes corresponds to a number of the multiple scan elements. A substrate may be electrically coupled to the second electrode and/or the first electrode and a cover may be positioned over the first electrode. The cover may have an acoustic impedance matching ultrasonic signals emitted by the piezoelectric material. As such, the ultrasonic biometric scanner may be capable of obtaining more accurate biometric scans, such as fingerprint scans, than non-multiple scan element ultrasonic biometric scanners while being capable of occupying a smaller space.

In various implementations, the piezoelectric material may be a material such as lead zirconate titanate (PZT) or polyvinylidene difluoride (PVDF). In some implementations, notches may be formed in the first or second surfaces. Such notches may separate the multiple electrodes. In various implementations, the piezoelectric material may be formed of a number of piezoelectric elements that may correspond to the number of multiple scan elements. Such elements may be laminated and/or otherwise adhered together. In such an implementation, each element may include separate first and second electrodes.

In some implementations, such as implementations where the piezoelectric material is PVDF, the piezoelectric material may not include a dedicated second electrode. In such implementations, the piezoelectric material may directly overlay conductive portions of the substrate, such as contact pads, and such conductive portions may constitute the second electrode.

The substrate may be configured to absorb the emitted ultrasonic signal. In some implementations, the substrate may be an application specific integrated circuit. The substrate may be coupled to an electrical connector such as a flex circuit and/or a stiffener such as a plastic stiffener. In some implementations, the stiffener may be configured to absorb the emitted ultrasonic signal.

4

In various implementations, the ultrasonic biometric scanner may be incorporated into an electronic device. In such implementations, the cover may be coupled to an interior portion of an exterior surface of the electronic device, such as a cover glass.

FIG. 1 is an isometric view of an example system 100 for biometric scanning using a multiple scan element array ultrasonic biometric scanner. As illustrated, the example system includes a electronic device 101 with an exterior surface 102 that is configured with an area 103 for scanning fingerprints.

However, though the electronic device 101 is illustrated as a smart phone, it is understood that this is an example. In various implementations, the electronic device may be any kind of electronic device such as a cellular telephone, a laptop computer, a mobile computer, a digital media player, a desktop computer, a tablet computer, an accessory, a charging dock, a wearable device, and/or any other kind of electronic device without departing from the scope of the present disclosure.

Further, although the exterior surface 102 is illustrated as a cover glass, it is understood that this is an example. In various implementations, the exterior surface may be any kind of exterior surface such as a touch screen, a button, a touch pad, a housing (such as a plastic or metal housing portion), and/or any other kind of exterior surface without departing from the scope of the present disclosure.

Additionally, although the area 103 is described as configured for scanning fingerprints, it is understood that this is an example. In various implementations, the area may be configured for scanning any kind of body part such as palm prints, footprints, and/or any other kind of body part without departing from the scope of the present disclosure. Further, although the area is shown as being located on a particular place on the electronic device 101 and having a particular shape and dimensions, it is understood that this is an example. In various implementations, the area may be located substantially anywhere on the electronic device and have any suitable shape and/or dimensions.

The electronic device 101 may include an ultrasonic biometric scanner, which may be a multiple scan element array ultrasonic biometric scanner, positioned within the electronic device under the area 103 (see for example FIGS. 2, 4, and 5). Such an ultrasonic biometric scanner may utilize piezoelectric material to produce ultrasonic signals. Materials between the piezoelectric material and the exterior portion of the area may have an acoustic impedance matching the ultrasonic signals such that the ultrasonic signals emitted from the piezoelectric material to the exterior portion of the area. However, air and/or an object touching the exterior portion of the area, such as a fingertip and/or other body part of a user, may have an acoustic impedance mismatched with the ultrasonic signal. As such, when the ultrasonic signal encounters the air or other object, the ultrasonic signal may be directed back toward the piezoelectric material. The piezoelectric material may receive the redirected signal and the redirected signal may be analyzed to determine whether or not an object is touching the exterior portion of the area and/or to determine one or more characteristics of that object, such as ridges and valleys of a user's fingerprint. For example, air may reflect the ultrasonic signal the strongest and the gradation of weaker received redirected signals may indicate ridges and valleys of a user's fingerprint, depth of valleys of a user's fingerprint, and so on. In this way, a biometric scan such as a fingerprint scan of a user may be obtained.

In implementations where the ultrasonic biometric scanner is a multiple scan element array ultrasonic biometric scanner, ultrasonic signals may be emitted and received by individual scan elements of the array that each include piezoelectric material. As such, the ultrasonic biometric scanner may be capable of obtaining more accurate biometric scans, such as fingerprint scans, than non-multiple scan element ultrasonic biometric scanners while being capable of occupying a smaller space. A variety of techniques may be utilized to prevent interference of individual scan elements with each other, examples of which are elaborated below.

The scan elements of the multiple scan element array ultrasonic biometric scanner may be driven in a variety of different patterns of emitting and/or receiving utilizing a variety of different techniques. For example, a wide band sensing technique may cause all scan elements to emit a single sine pulse of any given frequency. One example being 50 MHz. Scan elements may then receive the redirected sine pulse and the received redirected sine pulse may be analyzed based on travel time and amplitude to obtain the results of the scan.

By way of another example, a narrowband sensing technique may cause the scan elements to emit and receive multiple narrowband cycles of sine waves until into a steady state is reached. Once the scan elements are in the steady state, an ultrasonic signal may again be transmitted and received by the scan elements, which may then be analyzed to obtain the results of the scan.

In still another example, various combinations of one or more scan elements of the array may be separately driven to emit and/or receive ultrasonic signals. Such a technique may be performed when an object such as a user's fingerprint is determined to be positioned over part but not all of the array (which may be determined utilizing techniques such as measuring detected capacitance). In this way, energy consumption may be reduced compared to driving all scan elements when not all information obtained utilizing all scan elements would be relevant to a scan.

Additionally, the electronic device **101** may include one or more other components not shown. Such other components may include one or more processing units, one or more communication components, one or more input/output components, one or more user interface components, one or more non-transitory storage media (which may take the form of, but is not limited to, a magnetic storage medium; optical storage medium; magneto-optical storage medium; read only memory; random access memory; erasable programmable memory; flash memory; and so on), and/or various other components.

FIG. 2 is a cross sectional view of a first example ultrasonic biometric scanner that may be used in the example system **100** of FIG. 1 taken along the line A-A of FIG. 1. As illustrated, the ultrasonic biometric scanner may include piezoelectric material **209**, which may be a material such as PZT or PVDF. A first electrode **206** may be positioned on a first surface (illustrated in this example as a top surface) of the piezoelectric material and second electrodes **210** may be positioned on a second surface of the piezoelectric material (illustrated as the opposing bottom surface). A cover **203** that has an acoustic impedance matching ultrasonic signals produced by the piezoelectric material may be positioned over the first electrode. As illustrated in this example, the cover may include a layer of glass-filled epoxy **204** and a layer of conductive epoxy **205**. The second electrodes may be electrically coupled to conductive portions of a substrate **215** (which may be an application

specific integrated circuit), such as via flip chip solder balls **211** and contact pads **212**. The first electrode may also be electrically coupled to conductive portions of the substrate, such as via interconnect **207** (which is illustrated as connecting the first electrode to the substrate around the piezoelectric material), flip chip solder ball **213**, and contact pad **214**.

In some implementations, the second electrodes **210** may correspond to the multiple scan elements of the array. As such, a number of second electrodes may be utilized that corresponds to the number of multiple scan elements. Utilization of separate second electrodes by individual scan elements may aid in reducing and/or preventing ultrasonic signal interference between the individual scan elements of the array.

The cover **203** may be coupled to an interior portion of the exterior surface **102**. As illustrated, the cover may be coupled to a cover glass **201** that includes an interior opaque layer **202**, such as white, gray, and/or other colored inks.

In various implementations, the substrate **215** may be configured to absorb the ultrasonic signals emitted by the piezoelectric material **209**. The piezoelectric material may emit ultrasonic signals in a variety of directions. However, ultrasonic signals that are not transmitted toward and received back from the cover **203** may not be relevant to a biometric scan and may in fact interfere with the ultrasonic signals transmitted toward and received redirected back from the cover. As such, absorption of ultrasonic signals by the substrate may prevent ultrasonic signals not relevant to a biometric scan from interfering with receiving and analysis of ultrasonic signals relevant to a biometric scan.

The substrate **215** may be electrically coupled to another portion of the electronic device **101** via an electrical connector **219**. For example, the electrical connector may be a flex circuit and the substrate may be electrically connected thereto via land grid array solder **218**. As illustrated, the second electrodes **210** may electrically couple to a first surface of the substrate (illustrated as a top surface) and a second surface (illustrated as the opposing bottom surface) may electrically couple to the electrical connector. In some implementations, the electrical connector may be configured to absorb the ultrasonic signals emitted by the piezoelectric material **209**.

In some implementations, the substrate **215** may be coupled to a stiffener **216**, which may be formed of plastic and/or any other material. Such a stiffener may provide vertical support, rigidity, and/or other strengthening or support for the substrate, the piezoelectric material, and/or any other component of the ultrasonic biometric scanner. As illustrated, a first portion of the second surface of the substrate opposite the contact pads **212** is coupled to the stiffener and another portion outside that first portion is coupled to the electrical connector **219**, the electrical connector then being coupled to the stiffener via a connection mechanism **217** such as pressure sensitive adhesive. However, it is understood that this is an example and other configurations are possible and contemplated without departing from the scope of the present disclosure. In various implementations, the stiffener may be configured to absorb the ultrasonic signals emitted by the piezoelectric material **209**.

As illustrated, an encapsulant **208** may surround one or more portions of the substrate **215**, the piezoelectric material **209**, the cover **203**, and so on. Such an encapsulant may isolate various electronic components, provide strength and/or other structural functions, form a barrier against entry of contaminants, and/or perform various other functions.

In some implementations, the capacitance of the first electrode **206** may change when an object such as a user's fingertip is brought proximate to the exterior surface **102**. In such implementations, the capacitance of the first electrode may be monitored for such a change and the piezoelectric material **209** may be stimulated to emit the ultrasonic signals upon detection of such a change. In this way, power consumption may be reduced by driving the scan elements when an object to be scanned is determined to be present.

Although FIG. 2 illustrates components with particular dimensions, it is understood that this is an example and not intended to be limiting. Components with a variety of differing dimensions may be utilized without departing from the scope of the present disclosure. Further, one or more layers may be omitted and/or made of a different material and/or one more additional layers may be added without departing from the scope of the present disclosure.

For example, in various implementations the cover glass **201** may be 800 microns thick from the exterior surface to the interior surface where the opaque layer **202** is coupled, the opaque layer may be 50 microns thick, the glass-filled epoxy **204** may be 8 microns thick, the layer of conductive epoxy **205** may be 15 microns thick, the first electrode **206** may be 5 microns thick, the piezoelectric material **209** may be PZT that is 88 microns thick, the substrate may be 200 microns thick, and the stiffener may be 200 microns thick.

However, this again is an example. In various other implementations the piezoelectric material may be PVDF that is 22 microns thick between the first electrode **206** and the second electrodes **210**. Further, the thicknesses of the other materials may also be different in various embodiments.

Additionally, although the first example ultrasonic biometric scanner is described above and illustrated in FIG. 2 as including particular components configured in a particular manner, it is understood that this is an example. In various implementations, the same, similar, and/or different components may be configured in a variety of different manners without departing from the scope of the present disclosure.

For example, the first electrode **206** is illustrated and described as a single electrode. However, in various implementations the first electrode may be a number of separate electrodes. In some instances of such an implementation, a separate first electrode may be included for each of the scan elements without departing from the scope of the present disclosure.

By way of another example, the second electrodes are illustrated as multiple separate electrodes. However, in various implementations the second electrodes may be a single, unified second electrode without departing from the scope of the present disclosure.

FIG. 3A is a first example of an ultrasonic multiple scan element array that may be utilized in the example ultrasonic biometric scanner of FIG. 2. Similar to FIG. 2, a top electrode **306a** may be positioned over piezoelectric material **309a** (such as PZT or PVDF). Also similar to FIG. 2, bottom electrodes **310a** may be positioned under the piezoelectric material. As illustrated, the bottom electrodes are not positioned over the entirety of the bottom surface of the piezoelectric material. This separation between bottom electrodes may aid in reducing and/or preventing ultrasonic signal interference between the individual scan elements of the array.

FIG. 3B is a second example of an ultrasonic multiple scan element array that may be utilized in the example ultrasonic biometric scanner of FIG. 2. By way of contrast with the first example of ultrasonic multiple scan element

array of FIG. 3A, the second example of ultrasonic multiple scan element array may include notches **320** and/or other gaps formed (such as by cutting, grinding, and/or other processes) in the bottom surface of piezoelectric material **309b** (such as PZT or PVDF). These notches may aid in reducing and/or preventing ultrasonic signal interference between the individual scan elements of the array.

FIG. 3C is a third example of an ultrasonic multiple scan element array that may be utilized in the example ultrasonic biometric scanner of FIG. 2. By way of contrast with the first example of ultrasonic multiple scan element array of FIG. 3A, the third example of ultrasonic multiple scan element array may include a number of separate piezoelectric elements (such as PZT or PVDF) **309c** instead of a single, unitary piece of piezoelectric material. The number of separate and discrete piezoelectric elements may correspond to the number of multiple scan elements in the array. The separate and discrete piezoelectric elements may be affixed/attached to each other, such as utilizing an adhesive. Further, each piezoelectric element may include a dedicated top electrode **306c** and a dedicated bottom electrode **310c**. The use of separate piezoelectric elements and/or the use of dedicated top and/or bottom electrodes for each of the separate piezoelectric elements may aid in reducing and/or preventing ultrasonic signal interference between the individual scan elements of the array.

In some implementations, the piezoelectric elements **309c** may be formed by cutting or dicing a single piece of piezoelectric material. The cut or diced piezoelectric elements may then be laminated (such as utilizing epoxy) and/or otherwise adhered together.

FIG. 4 is a cross sectional view of a second example ultrasonic biometric scanner that may be used in the example system **100** of FIG. 1 taken along the line A-A of FIG. 1. By way of contrast with FIG. 2, the solder ball **213** and the contact pad **214** are positioned under the piezoelectric material **209** and the interconnect **207** runs along a side of the piezoelectric material as opposed to through the encapsulant **208**.

FIG. 5 is a cross sectional view of a third example ultrasonic biometric scanner that may be used in the example system **100** of FIG. 1 taken along the line A-A of FIG. 1. By way of contrast with FIG. 2, the piezoelectric material **209** may be PVDF or other material that may be directly stimulated by contact pads **212**. As such, the piezoelectric material may be directly positioned over the contact pads of the substrate **215** without use of interconnect structures such as the second electrodes **210** and/or the solder balls **211**. In such an implementation, the contact pads would constitute the second electrodes of the ultrasonic multiple scan element array.

FIG. 6 is a method diagram illustrating an example method for assembling an ultrasonic biometric scanner. This method may assemble the example systems of FIGS. 1-5.

The flow begins at block **601** where an ultrasonic multiple scan element array is formed. The ultrasonic multiple scan element array may include multiple scan elements. The array may be formed by positioning a first electrode on a first surface of piezoelectric material and a number of second electrodes on a second surface that opposes the first surface. The number of second electrodes may correspond to the number of the multiple scan elements.

The flow then proceeds to block **602** where a substrate is electrically coupled to the second electrodes of the ultrasonic multiple scan element array.

Next, the flow proceeds to block **603** where a cover is positioned over the first electrode of the ultrasonic multiple

scan element array. The cover may have an acoustic impedance that matches an ultrasonic signal the piezoelectric material is operable to emit to obtain a biometric scan of a body part via the cover.

Although the method 600 is illustrated and described above as including particular operations performed in a particular order, it is understood that this is an example. In various implementations, various orders of the same, similar, and/or different operations may be performed without departing from the scope of the present disclosure.

For example, various implementations may include performance of one or more additional operations. In some implementations, an additional operation of cutting notches into the second surface that separates the second electrodes may be performed without departing from the scope of the present disclosure. In other implementations, additional operations of cutting piezoelectric material into separate piezoelectric elements and laminating the separate piezoelectric elements together utilizing epoxy may be performed without departing from the scope of the present disclosure.

As discussed above and illustrated in the accompanying figures, the present disclosure discloses apparatuses, systems, and methods related to multiple scan element array ultrasonic biometric scanners. An ultrasonic biometric scanner may include an ultrasonic multiple scan element array with multiple scan elements having piezoelectric material with a first electrode on a first surface and a number of second electrodes on a second, opposite surface. The number of second electrodes may correspond to the number of multiple scan elements. A substrate may be electrically coupled to the second electrodes and a cover may be positioned over the first electrode. The cover may have an acoustic impedance matching ultrasonic signals emitted by the piezoelectric material. As such, the ultrasonic biometric scanner may be capable of obtaining more accurate biometric scans, such as fingerprint scans, than non-multiple scan element ultrasonic biometric scanners while being capable of occupying a smaller space.

In the present disclosure, the methods disclosed may be implemented utilizing sets of instructions or software readable by a device. Further, it is understood that the specific order or hierarchy of steps in the methods disclosed are examples of sample approaches. In other embodiments, the specific order or hierarchy of steps in the method can be rearranged while remaining within the disclosed subject matter. The accompanying method claims present elements of the various steps in a sample order, and are not necessarily meant to be limited to the specific order or hierarchy presented.

Techniques of the described disclosure may utilize a computer program product, or software, that may include a non-transitory machine-readable medium having stored thereon instructions, which may be used to program a computer system (or other electronic devices) to perform a process according to the present disclosure. A non-transitory machine-readable medium includes any mechanism for storing information in a form (e.g., software, processing application) readable by a machine (e.g., a computer). The non-transitory machine-readable medium may take the form of, but is not limited to, a magnetic storage medium (e.g., floppy diskette, video cassette, and so on); optical storage medium (e.g., CD-ROM); magneto-optical storage medium; read only memory (ROM); random access memory (RAM); erasable programmable memory (e.g., EPROM and EEPROM); flash memory; and so on.

It is believed that the present disclosure and many of its attendant advantages will be understood by the foregoing

description, and it will be apparent that various changes may be made in the form, construction and arrangement of the components without departing from the disclosed subject matter or without sacrificing all of its material advantages.

The form described is merely explanatory, and it is the intention of the following claims to encompass and include such changes.

While the present disclosure has been described with reference to various embodiments, it will be understood that these embodiments are illustrative and that the scope of the disclosure is not limited to them. Many variations, modifications, additions, and improvements are possible. More generally, embodiments in accordance with the present disclosure have been described in the context or particular embodiments. Functionality may be separated or combined in blocks differently in various embodiments of the disclosure or described with different terminology. These and other variations, modifications, additions, and improvements may fall within the scope of the disclosure as defined in the claims that follow.

We claim:

1. An ultrasonic biometric scanner, comprising:
  - an ultrasonic multiple scan element array including multiple scan elements, comprising:
    - piezoelectric material having a first surface and a second surface opposing the first surface;
    - a first electrode positioned on the first surface; and
    - a second electrode positioned on the second surface;
  - a substrate electrically coupled to the second electrode; and
  - a cover positioned over the first electrode;
 wherein:
  - at least one of the first electrode or the second electrode include multiple electrodes wherein the number of the multiple electrodes corresponds to a number of the multiple scan elements;
  - the substrate is acoustically coupled to the piezoelectric material and configured to absorb the ultrasonic signal; and
  - the ultrasonic biometric scanner is operable to obtain a biometric scan of a body part via the cover by causing the piezoelectric material to emit an ultrasonic signal.
2. The system of claim 1, wherein the piezoelectric material comprises one of lead zirconate titanate or polyvinylidene difluoride.
3. The system of claim 1, wherein:
  - the second electrode includes the multiple electrodes; and
  - the piezoelectric material includes notches in the second surface positioned between the multiple electrodes.
4. The system of claim 1, wherein the piezoelectric material comprises a number of piezoelectric elements corresponding to the number of the multiple scan elements.
5. The system of claim 4, wherein the number of piezoelectric elements are adhered together.
6. The system of claim 4, wherein each of the number of piezoelectric elements includes a separate first electrode.
7. The system of claim 1, wherein both the first electrode and the second electrode comprise multiple electrodes.
8. The system of claim 1, wherein the cover comprises a glass-filled epoxy layer and a conductive epoxy layer.
9. The system of claim 1, further comprising an electrical connector coupled to a first surface of the substrate wherein the substrate is electrically coupled to the second electrode via a second surface that opposes the first surface.
10. The system of claim 9, wherein the electrical connector comprises a flex circuit.

11

11. The system of claim 1, further comprising a stiffener coupled to a first surface of the substrate wherein the substrate is electrically coupled to the second electrode via a second surface that opposes the first surface.

12. The system of claim 11, wherein the substrate is acoustically coupled to the piezoelectric material, the stiffener is acoustically coupled to the substrate, and the stiffener is configured to absorb the ultrasonic signal.

13. The system of claim 1, further comprising encapsulant positioned over the substrate and around the piezoelectric material.

14. The system of claim 1, wherein the first electrode is electrically coupled to the substrate around the piezoelectric material.

15. The system of claim 1, wherein the substrate comprises an application specific integrated circuit.

16. The system of claim 1, wherein the ultrasonic biometric scanner causes the piezoelectric material to emit the ultrasonic signal in response to detection of a change in capacitance of the first electrode.

17. An electronic device, comprising:  
an exterior surface having an interior portion and an exterior portion; and  
an ultrasonic biometric scanner, comprising:  
an ultrasonic multiple scan element array including multiple scan elements, comprising:  
piezoelectric material having a first surface and a second surface opposing the first surface;  
a first electrode positioned on the first surface; and  
a second electrode positioned on the second surface;  
a substrate electrically coupled to the second electrode, the substrate acoustically coupled to the piezoelectric material;  
a stiffener acoustically coupled to the substrate; and  
a cover positioned over the first electrode, the cover coupled to the interior portion of the exterior surface;  
wherein:

12

at least one of the first electrode or the second electrode include multiple electrodes wherein the number of the multiple electrodes corresponds to a number of the multiple scan elements;

the ultrasonic biometric scanner is operable to obtain a biometric scan of a body part via the exterior surface by causing the piezoelectric material to emit an ultrasonic signal; and

the stiffener is configured to absorb the ultrasonic signal.

18. The electronic device of claim 17, wherein the exterior surface comprises a cover glass with an opaque layer on the interior portion.

19. An ultrasonic biometric scanner, comprising:  
an ultrasonic multiple scan element array including multiple scan elements, comprising: piezoelectric material having a first surface and a second surface opposing the first surface;

a first electrode positioned on the first surface; and a second electrode positioned on the second surface; a substrate electrically coupled to the second electrode; and

a cover positioned over the first electrode; wherein:

the second electrode includes multiple electrodes wherein the number of the multiple electrodes corresponds to a number of the multiple scan elements;

the piezoelectric material includes notches defined in the second surface positioned between the multiple electrodes;

the ultrasonic biometric scanner is operable to obtain a biometric scan of a body part via the cover by causing the piezoelectric material to emit an ultrasonic signal; and

the substrate is acoustically coupled to the piezoelectric material and configured to absorb the ultrasonic signal.

20. The ultrasonic biometric scanner of claim 19, wherein the notches reduce ultrasonic signal interference between the multiple scan elements.

\* \* \* \* \*