



(12) **United States Patent**
Abreu

(10) **Patent No.:** **US 9,606,375 B2**
(45) **Date of Patent:** **Mar. 28, 2017**

(54) **BIOLOGICALLY FIT WEARABLE ELECTRONICS APPARATUS**

(71) Applicant: **GEELUX HOLDINGS, LTD.**, Road Town, Tortola (VG)

(72) Inventor: **Marcio Marc Abreu**, Bridgeport, CT (US)

(73) Assignee: **GEELUX HOLDINGS, LTD.**, Tortola (VG)

(*) Notice: Subject to any disclaimer, the term of this patent is extended or adjusted under 35 U.S.C. 154(b) by 383 days.

(21) Appl. No.: **13/971,696**

(22) Filed: **Aug. 20, 2013**

(65) **Prior Publication Data**

US 2014/0078462 A1 Mar. 20, 2014

Related U.S. Application Data

(60) Continuation of application No. 12/805,032, filed on Jul. 8, 2010, now Pat. No. 8,540,363, which is a division of application No. 11/650,590, filed on Jan. 8, 2007, now Pat. No. 7,810,750, which is a continuation-in-part of application No. 11/637,952, filed on Dec. 13, 2006, now abandoned.

(60) Provisional application No. 60/762,861, filed on Jan. 30, 2006, provisional application No. 60/756,549, (Continued)

(51) **Int. Cl.**

- G02C 1/00** (2006.01)
- G02C 11/00** (2006.01)
- G02C 3/00** (2006.01)
- G02C 11/06** (2006.01)
- G02C 5/14** (2006.01)
- H04N 7/18** (2006.01)
- H04R 1/02** (2006.01)
- H04R 1/10** (2006.01)

(52) **U.S. Cl.**

CPC **G02C 11/10** (2013.01); **G02C 3/003** (2013.01); **G02C 5/14** (2013.01); **G02C 11/06** (2013.01); **H04N 7/185** (2013.01); **H04R 1/028** (2013.01); **H04R 1/1016** (2013.01); **H04R 2420/07** (2013.01)

(58) **Field of Classification Search**

CPC G02C 11/00; G02C 11/06
USPC 351/158, 41; 381/381; 345/8
See application file for complete search history.

(56) **References Cited**

U.S. PATENT DOCUMENTS

2,249,572 A	7/1941	Lieber
3,528,734 A	9/1970	Bruel et al.
4,456,797 A	6/1984	Olsen

(Continued)

FOREIGN PATENT DOCUMENTS

EP	1049310 A1	11/2000
GB	2320990 A	7/1998

(Continued)

OTHER PUBLICATIONS

English translation of a Notification of Reasons for Rejection; issued by the Japanese Patent Office on Feb. 13, 2012, which corresponds to Japanese Patent Application No. 2008-549558.

(Continued)

Primary Examiner — James Greece

(74) *Attorney, Agent, or Firm* — Studebaker & Brackett PC

(57) **ABSTRACT**

Detachable wearable electronic eyeglasses and head mounted gear with a plurality of electronic functions and interchangeable electronic function, and a wearable computer with optimal weight distribution and stretchable arms.

28 Claims, 310 Drawing Sheets

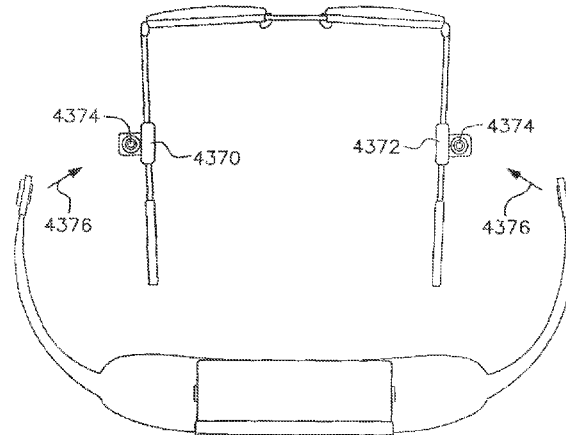

Related U.S. Application Data

filed on Jan. 6, 2006, provisional application No. 60/749,579, filed on Dec. 13, 2005.

(56)

References Cited

U.S. PATENT DOCUMENTS

4,902,120	A	2/1990	Weyer	
4,942,617	A	7/1990	Boylan	
5,034,995	A	7/1991	Cicccone	
5,164,987	A	11/1992	Raven	
5,422,957	A	6/1995	Cummins	
5,608,808	A	3/1997	da Silva	
5,715,323	A	2/1998	Walker	
5,737,436	A	4/1998	Boyden	
5,881,160	A	3/1999	Sheppard	
6,095,820	A	8/2000	Luxon et al.	
6,097,822	A	8/2000	Min	
6,176,576	B1	1/2001	Green et al.	
6,633,770	B1	10/2003	Gitzinger et al.	
6,643,528	B1	11/2003	Shim et al.	
6,690,808	B2	2/2004	Urwyler	
6,920,228	B2	7/2005	Redmer et al.	
D533,539	S	12/2006	Mah	
7,192,136	B2*	3/2007	Howell et al.	351/158
7,519,192	B1	4/2009	Laycock et al.	
7,702,122	B2	4/2010	Crutcher	
2001/0035242	A1	11/2001	Hughs et al.	
2002/0072387	A1	6/2002	Kao	
2002/0193151	A1	12/2002	Edreich	
2003/0036414	A1	2/2003	Huang	
2003/0040285	A1	2/2003	Whitley	
2003/0042348	A1	3/2003	Salentine et al.	
2003/0108217	A1	6/2003	Tilbury et al.	
2003/0182003	A1	9/2003	Takashima	
2004/0077382	A1	4/2004	Verity	
2004/0156012	A1*	8/2004	Jannard et al.	351/158
2004/0178970	A1*	9/2004	El Sayed et al.	345/8
2004/0204165	A1	10/2004	Huang	
2005/0078274	A1	4/2005	Howell et al.	
2005/0128431	A1	6/2005	Jannard et al.	
2005/0201585	A1	9/2005	Jannard et al.	
2005/0220316	A1	10/2005	Hsiang	
2005/0248717	A1	11/2005	Howell	
2005/0255883	A1	11/2005	Hood	
2005/0255898	A1	11/2005	Huang	
2006/0013410	A1	1/2006	Wurtz	
2006/0023158	A1	2/2006	Howell et al.	
2006/0093178	A1	5/2006	Chen	
2006/0153409	A1	7/2006	Yeh	
2006/0177086	A1	8/2006	Rye et al.	
2006/0185062	A1	8/2006	Peng et al.	
2006/0251283	A1	11/2006	Yeh	
2007/0064969	A1	3/2007	Chou	
2009/0175482	A1	7/2009	Crutcher	

FOREIGN PATENT DOCUMENTS

JP	S52-107638	U	8/1977
JP	58-113913	A	7/1983
JP	S61-125081	U	8/1986
JP	H63-120585	A	5/1988
JP	H01-129988	U	9/1989
JP	H06-81194	U	11/1994

JP	H06-081194	U	11/1994
JP	H07-209600	A	11/1995
JP	H07-312791	A	11/1995
JP	H08-237349	A	9/1996
JP	3043585	U	9/1997
JP	2002-515197	A	5/2002
JP	2002-238092	A	8/2002
JP	2002-278670	A	9/2002
JP	2003-505718	A	2/2003
JP	2005-534269		11/2005
JP	2009-527134	A	7/2009
WO	99/23524	A1	5/1999
WO	01/06298	A1	1/2001
WO	01/11917	A1	2/2001
WO	02/086599	A1	10/2002
WO	2004/012477	A2	2/2004
WO	2005/115048	A1	12/2005
WO	2007/081745	A2	7/2007

OTHER PUBLICATIONS

A Patent Examination Report No. 2; issued by the Australian Government, IP Australia on Aug. 7, 2014, which corresponds to Australian Patent Application No. 2013201164.

An Office Action issued by the Canadian Intellectual Property Office on Jun. 7, 2010, which corresponds to Canadian Patent Application No. 2,636,159.

A Third Office Action issued by the Canadian Intellectual Property Office on Apr. 10, 2013, which corresponds to Canadian Patent Application No. 2,636,159.

A Second Office Action issued by the Canadian Intellectual Property Office on May 16, 2012, which corresponds to Canadian Patent Application No. 2,636,159.

A "Communication pursuant to Article 94(3) EPC," issued by the European Patent Office on Nov. 19, 2012, which corresponds to European Patent Application No. 07 717 926.5-2217.

A Patent Examination Report No. 2; issued by the Australian Government, IP Australia on Jun. 28, 2012, which corresponds to Australian Patent Application No. 2007205168.

International Search Report and Written Opinion; PCT/US2007/000177; Feb. 20, 2008.

A "Decision of Grant," issued by the Japanese Patent Office on Apr. 13, 2015; which corresponds to Japanese Patent Application 2008-549558.

English translation of Notification of Reason for Refusal; issued by the Japanese Patent Office on May 11, 2015, which corresponds to Japanese Patent Application No. 2013-162822.

An English translation of an Office Action; "Notification of Reasons for Rejection," issued by the Japanese Patent Office; which corresponds to Japanese Patent Application 2013-162822 and is related to U.S. Appl. No. 13/971,696.

An Office Action; "Notification of Reasons for Rejection," issued by the Japanese Patent Office on May 12, 2014, which corresponds to Japanese Patent Application 2008-549558 and is related to U.S. Appl. No. 13/971,696; with English language translation.

Translation of JPO Office Action form corresponding JP 2013-162822, mailed May 9, 2016, pp. 4.

The extended European search report issued by the European Patent Office on Feb. 26, 2016, which corresponds to European Patent Application No. 15182392.9-1562 and is related to U.S. Appl. No. 13/971,696.

* cited by examiner

FIG. 1A
(PRIOR ART)

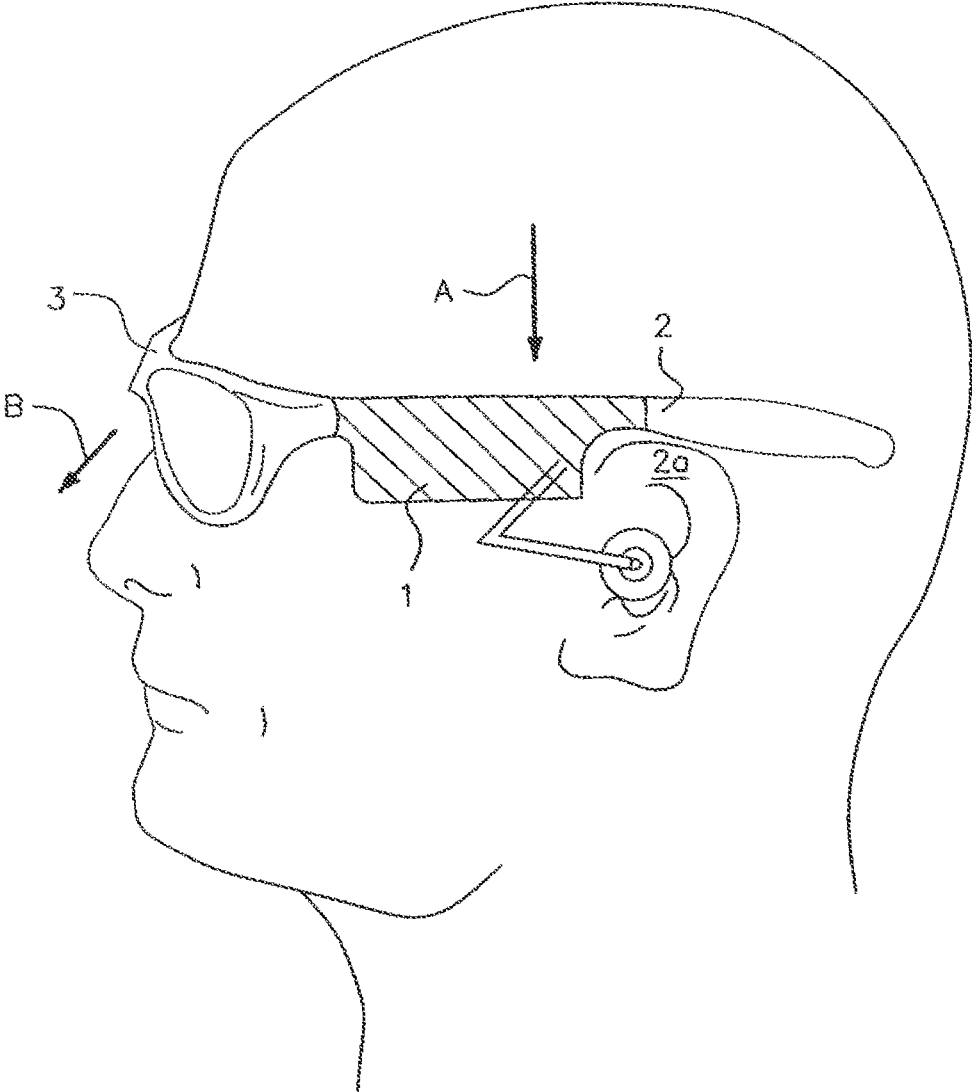

FIG. 1B

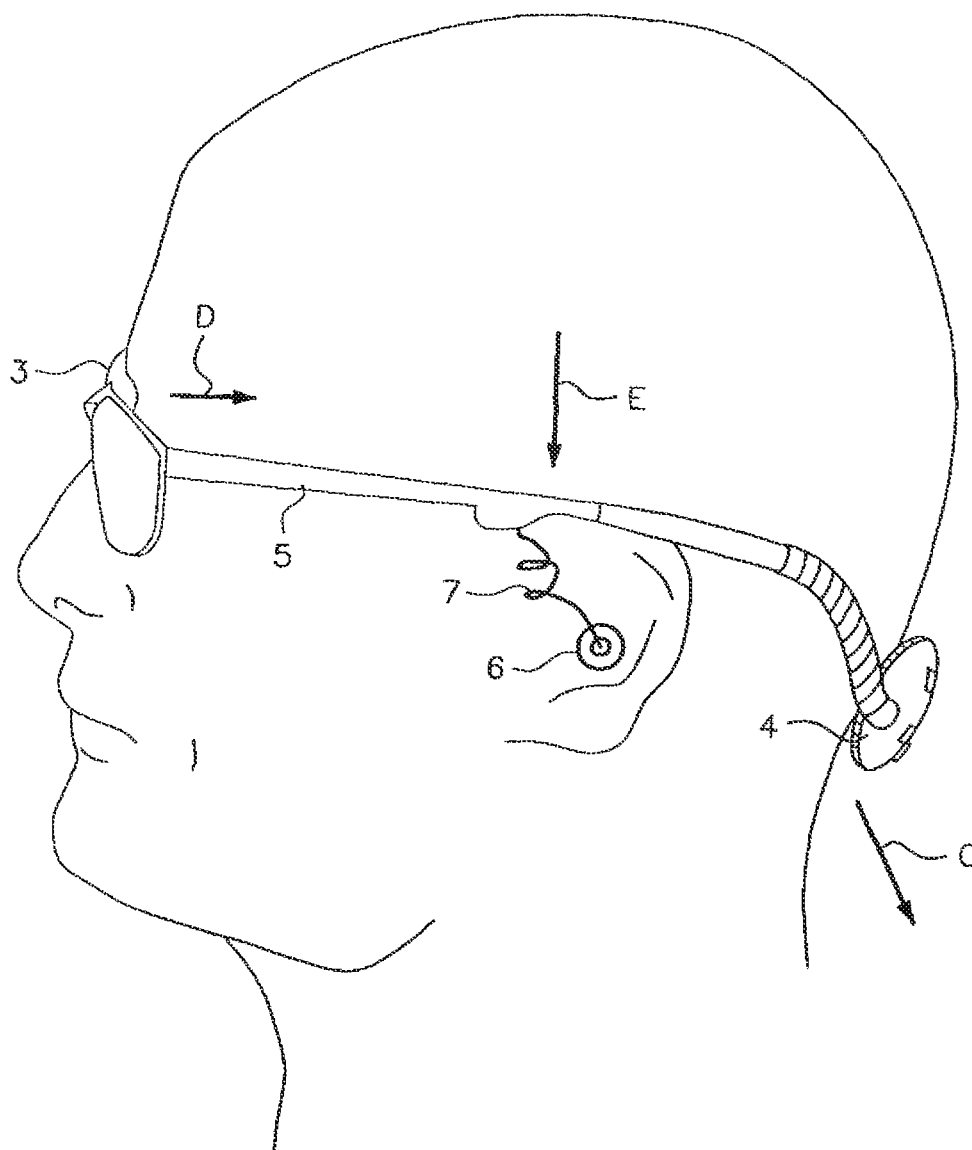

FIG. 1C

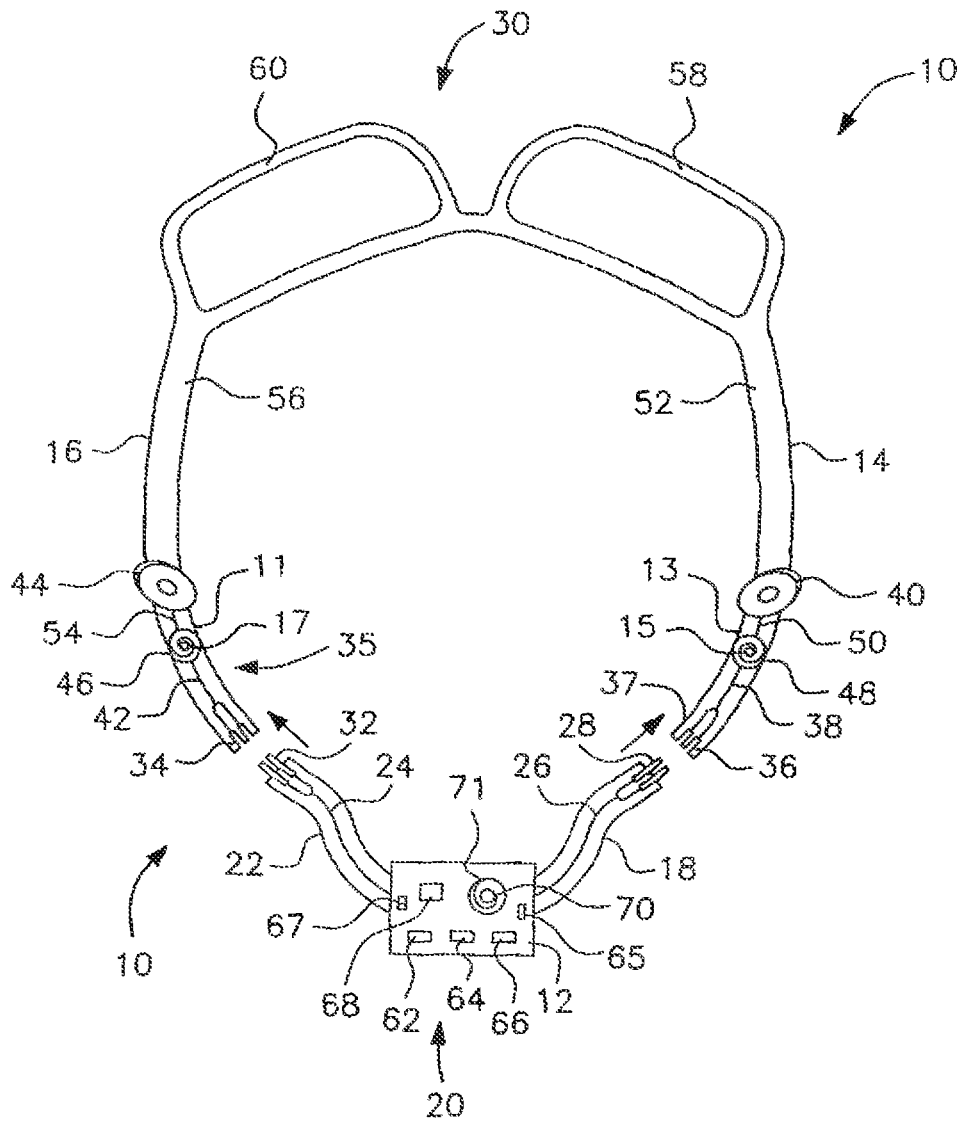

FIG. 1D

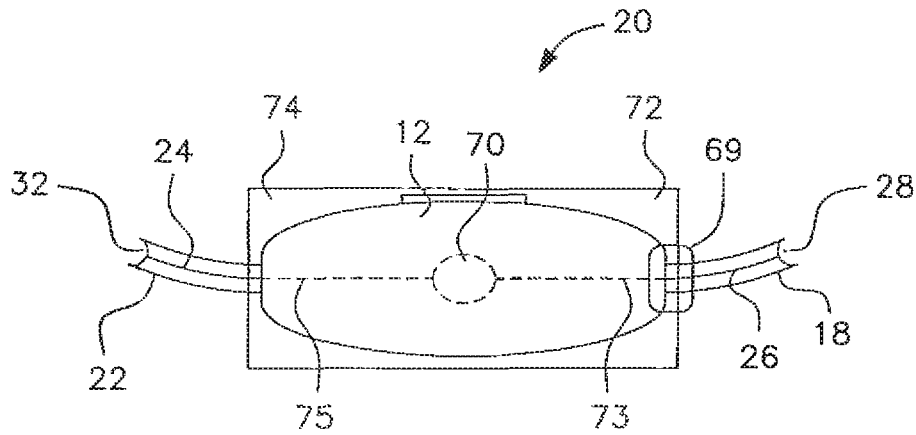

FIG. 1E

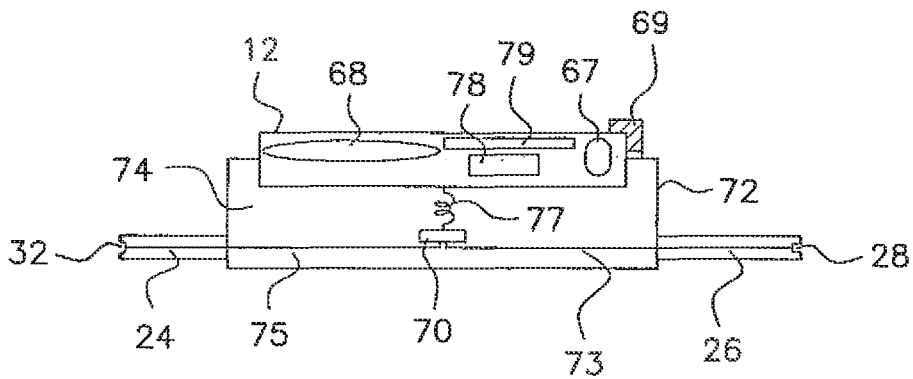

FIG. 1F

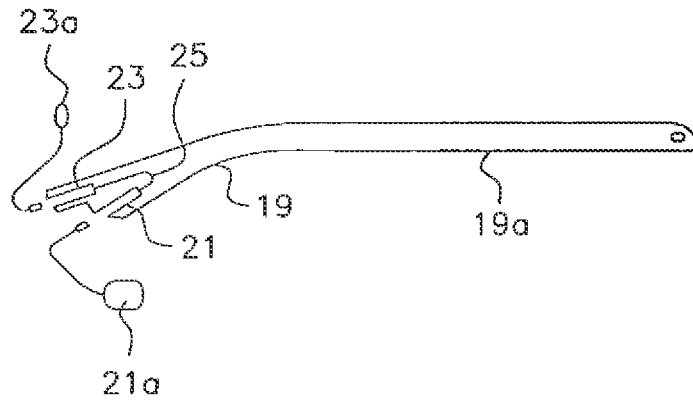

FIG. 1G
(PRIOR ART)

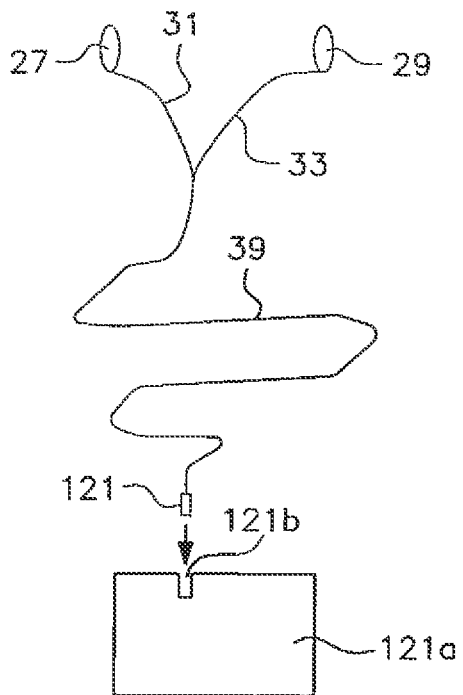

FIG. 1H

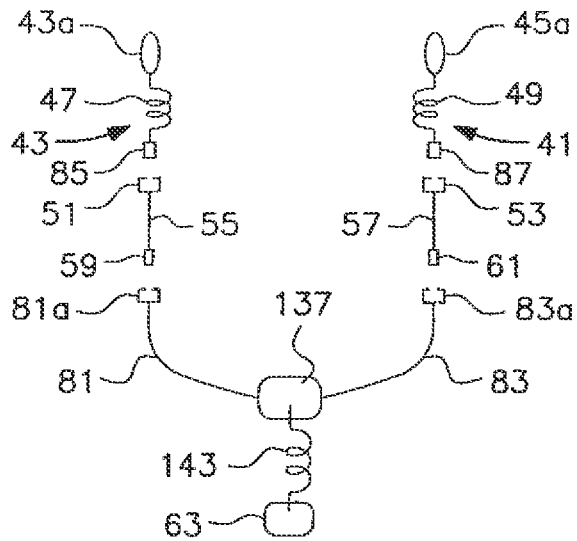

FIG. 1J

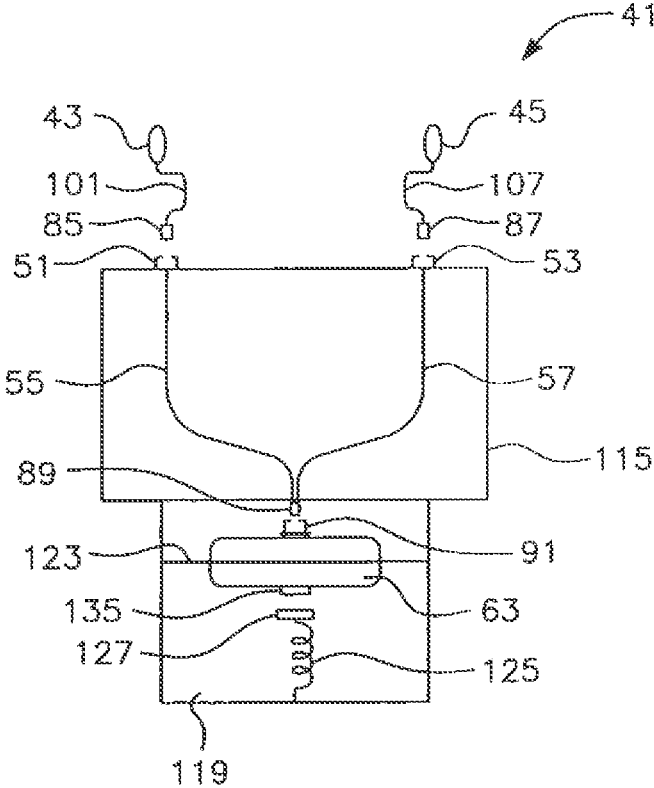

FIG. 2A

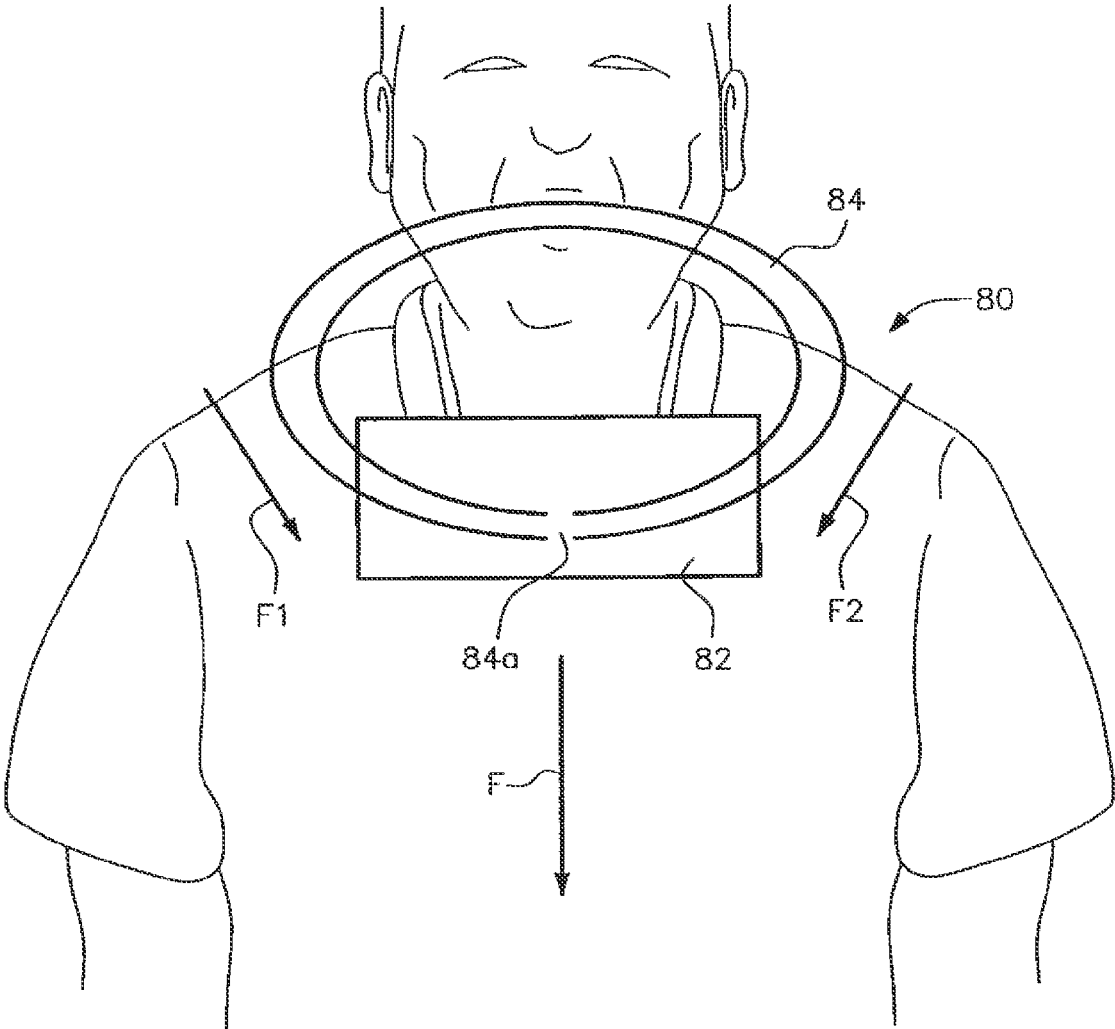

FIG. 2B

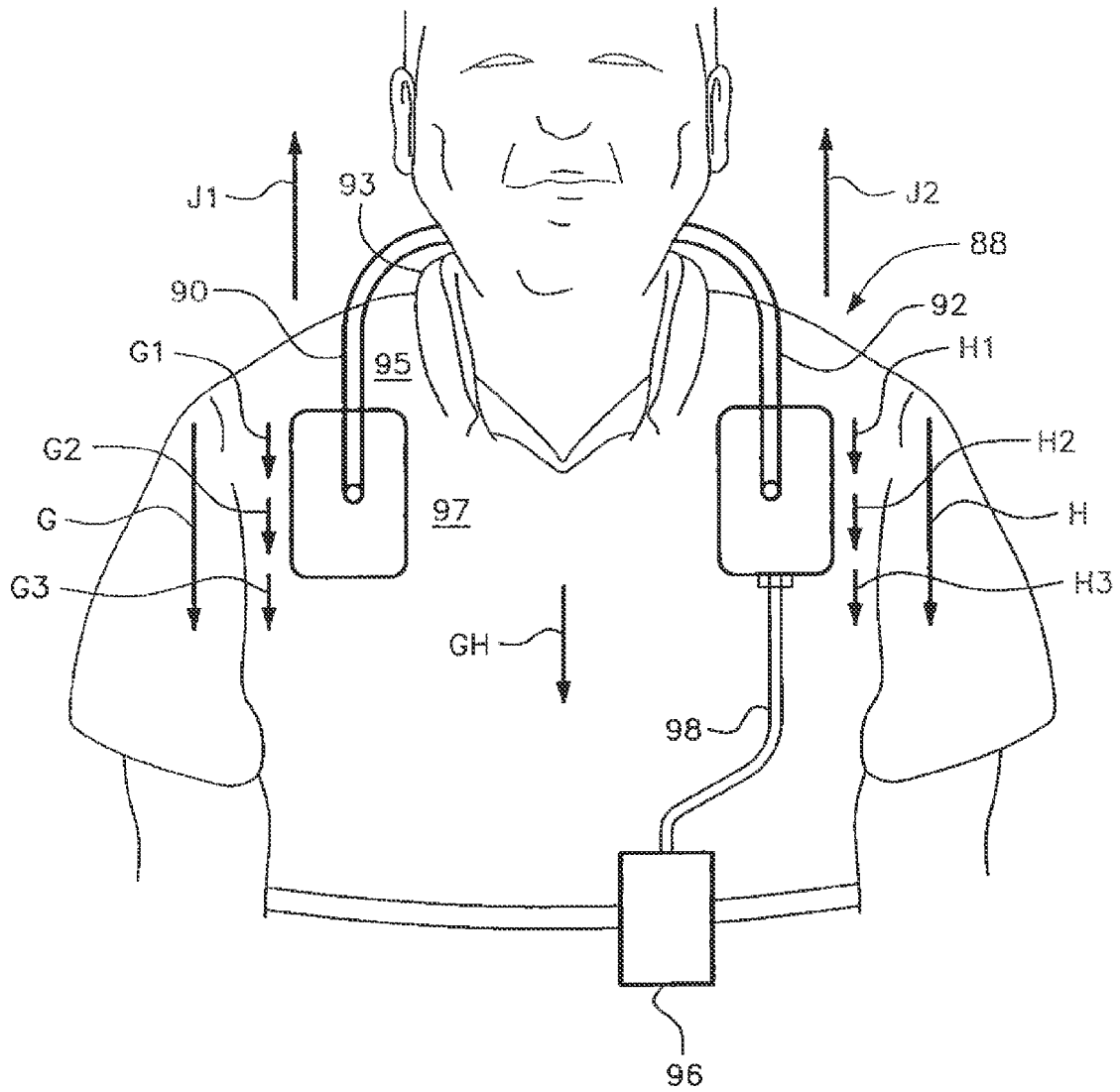

FIG. 3

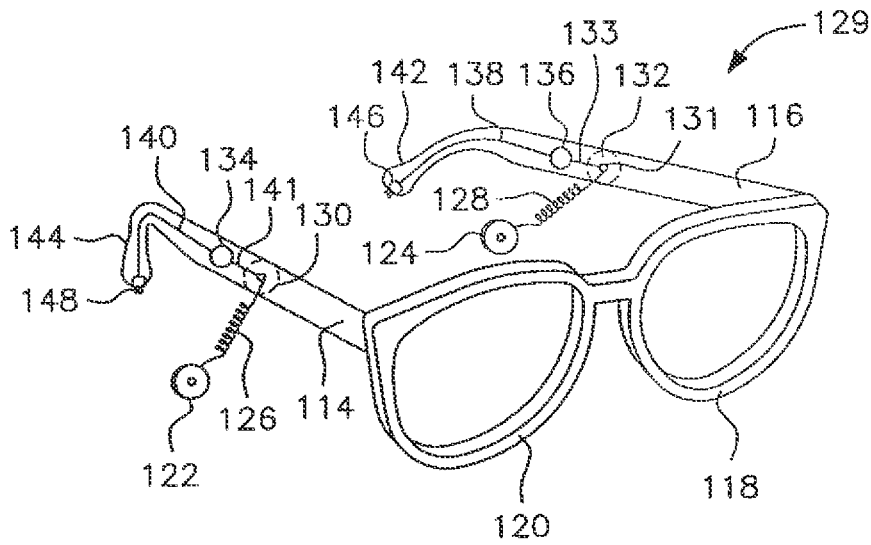

FIG. 4

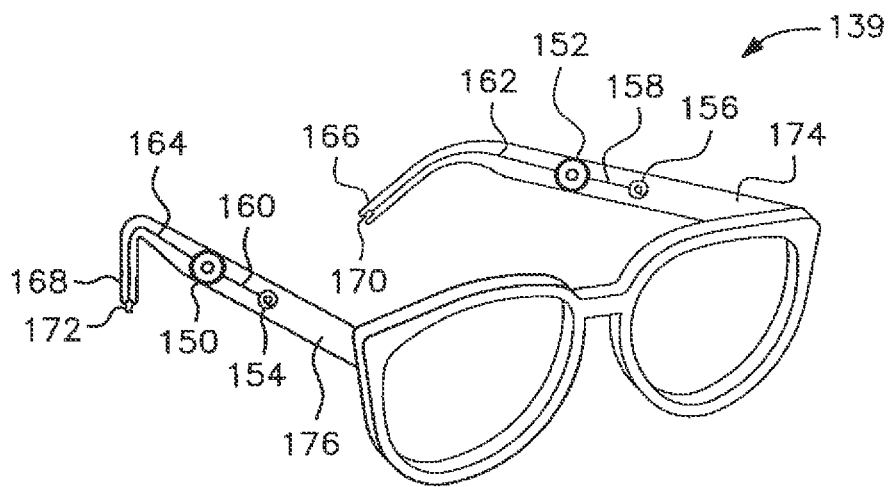

FIG. 5A

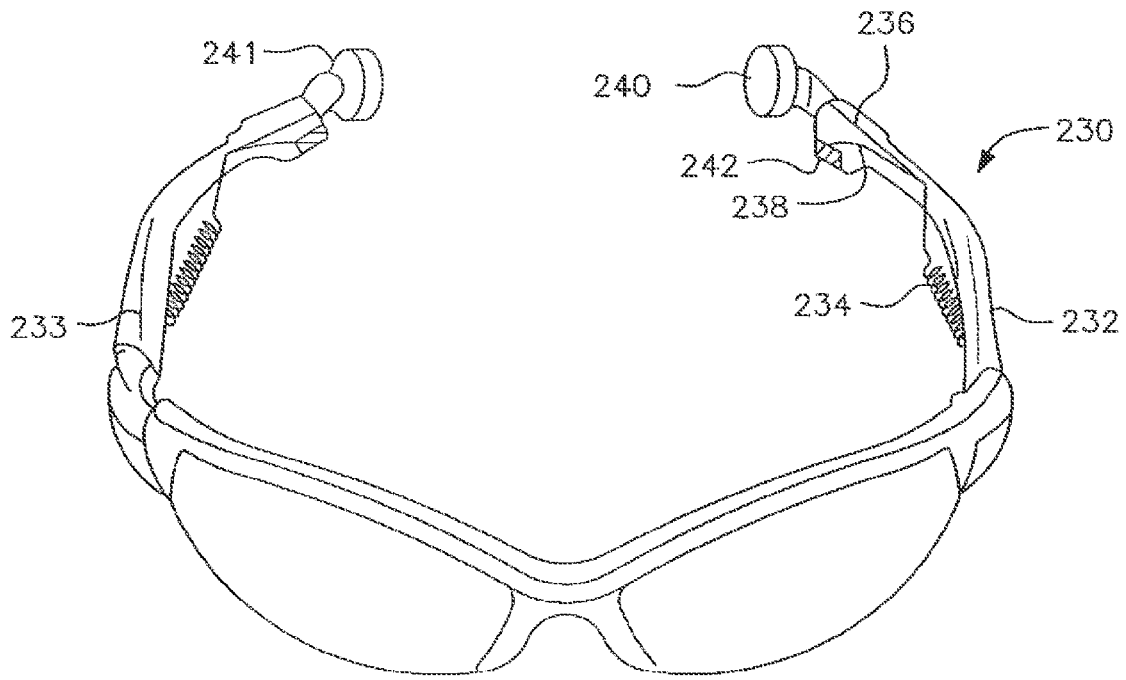

FIG. 5B

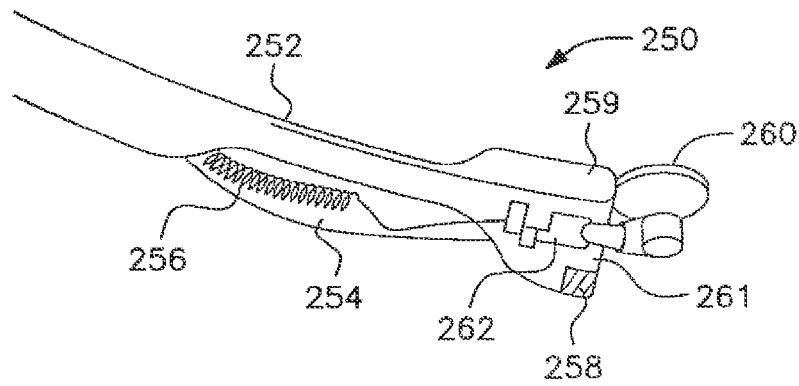

FIG. 5C

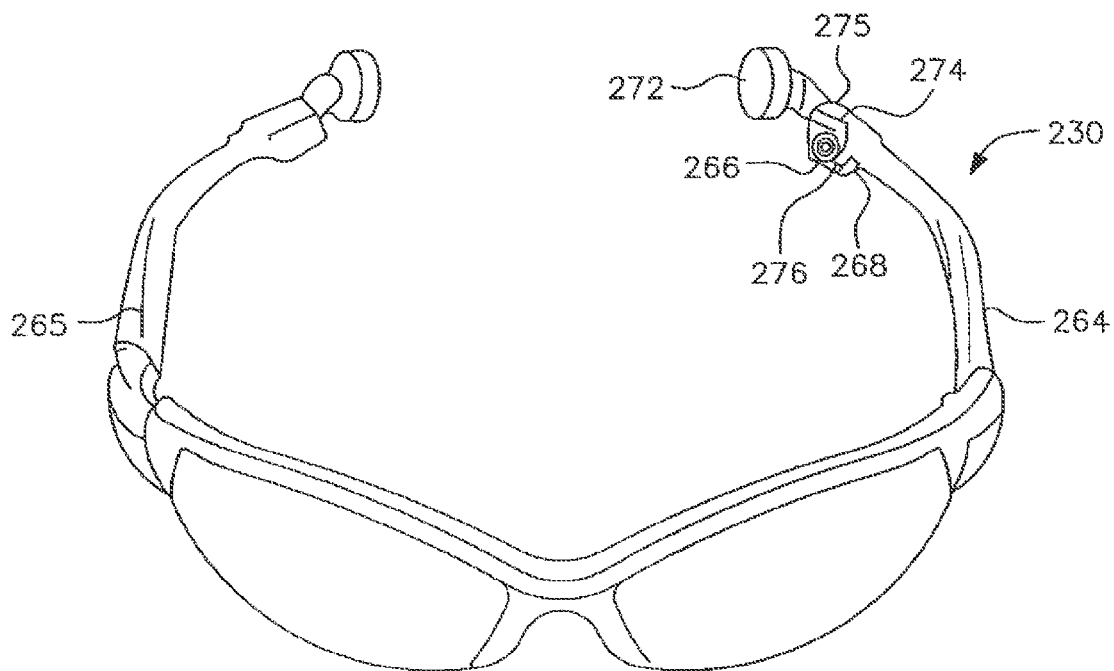

FIG. 5D

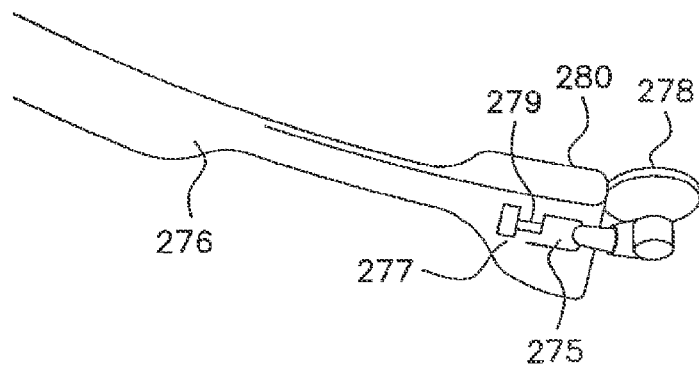

FIG. 5E

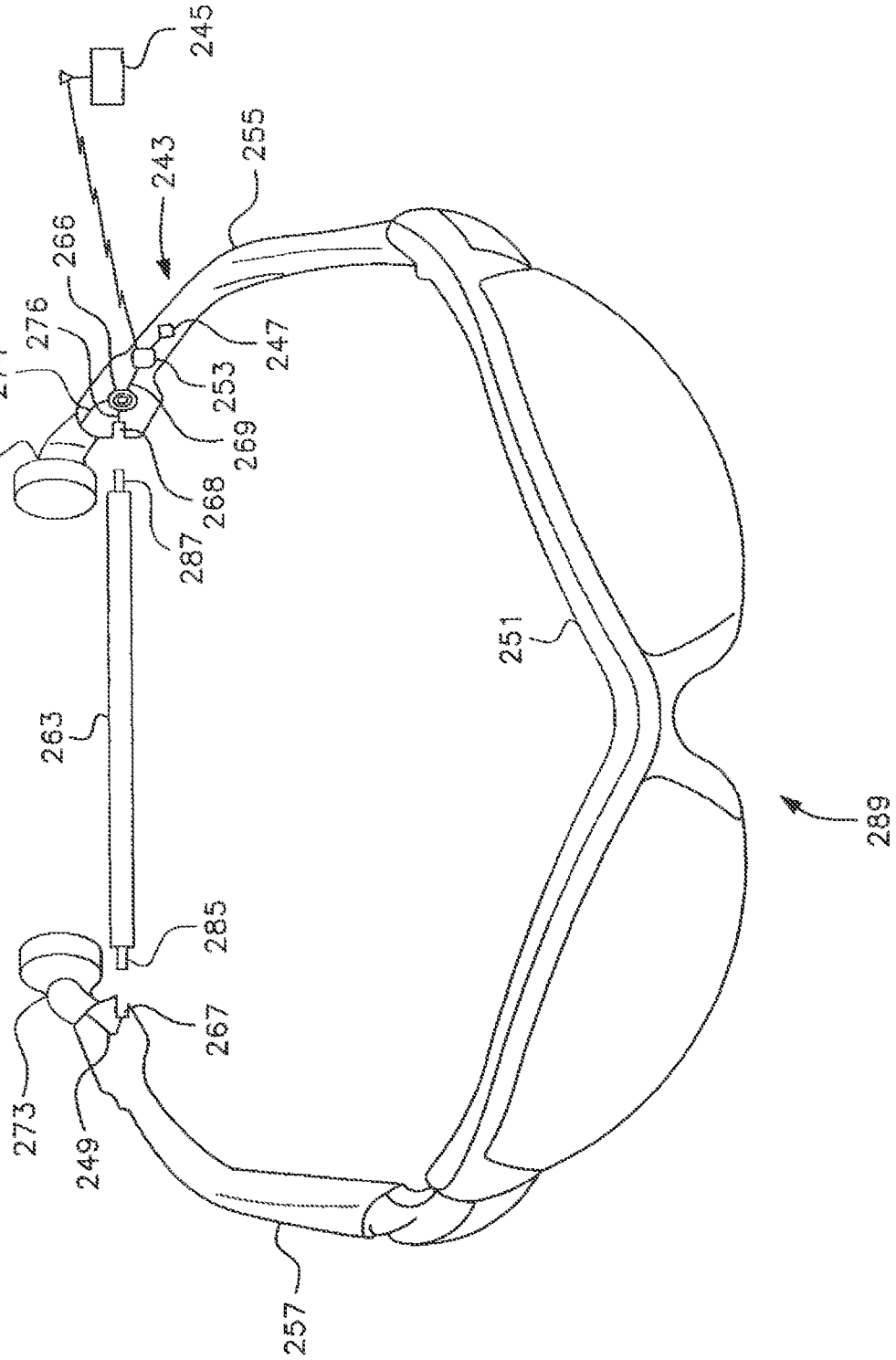

FIG. 6

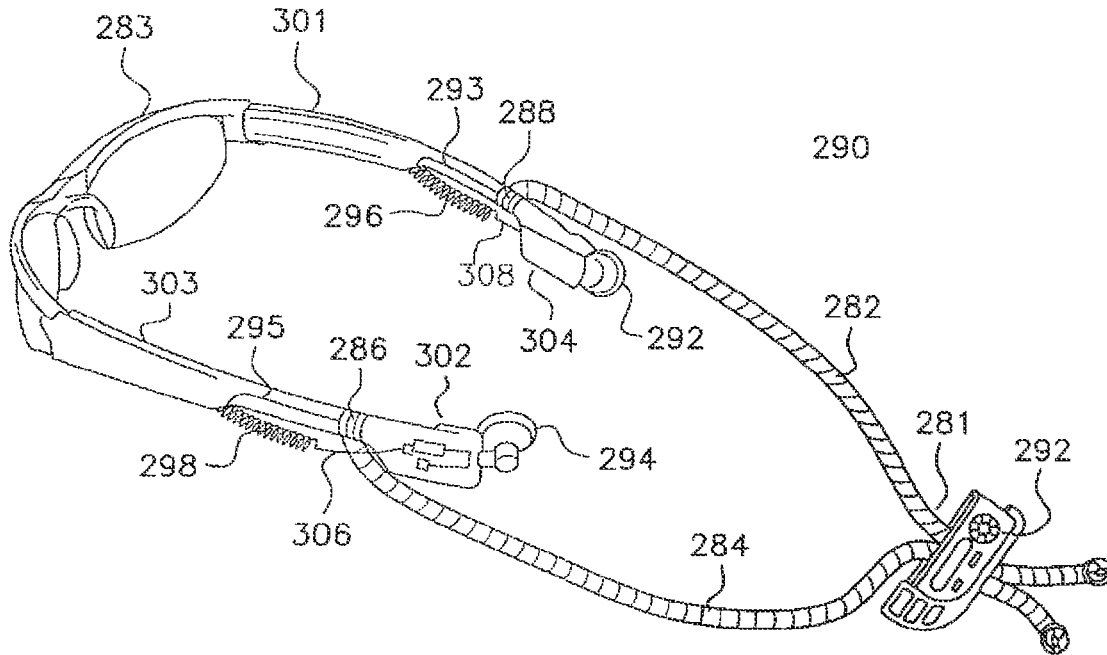

FIG. 6A

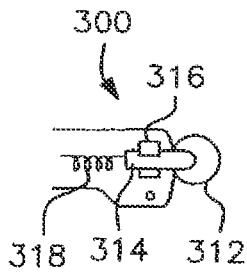

FIG. 6B

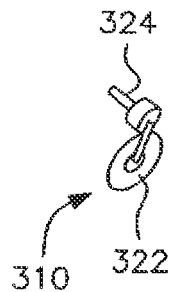

FIG. 6C

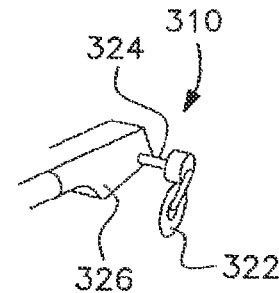

FIG. 6D

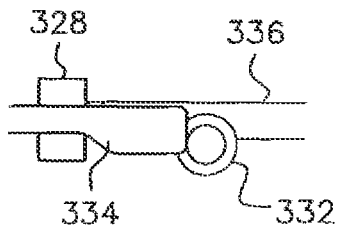

FIG. 6E

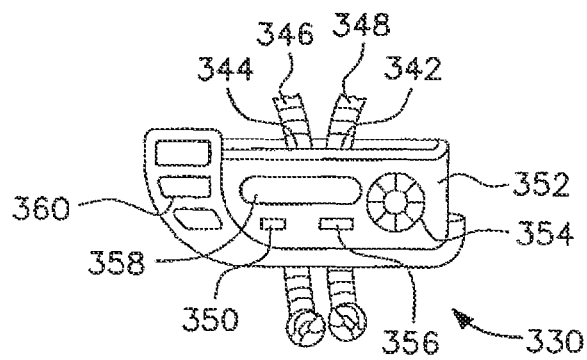

FIG. 6F

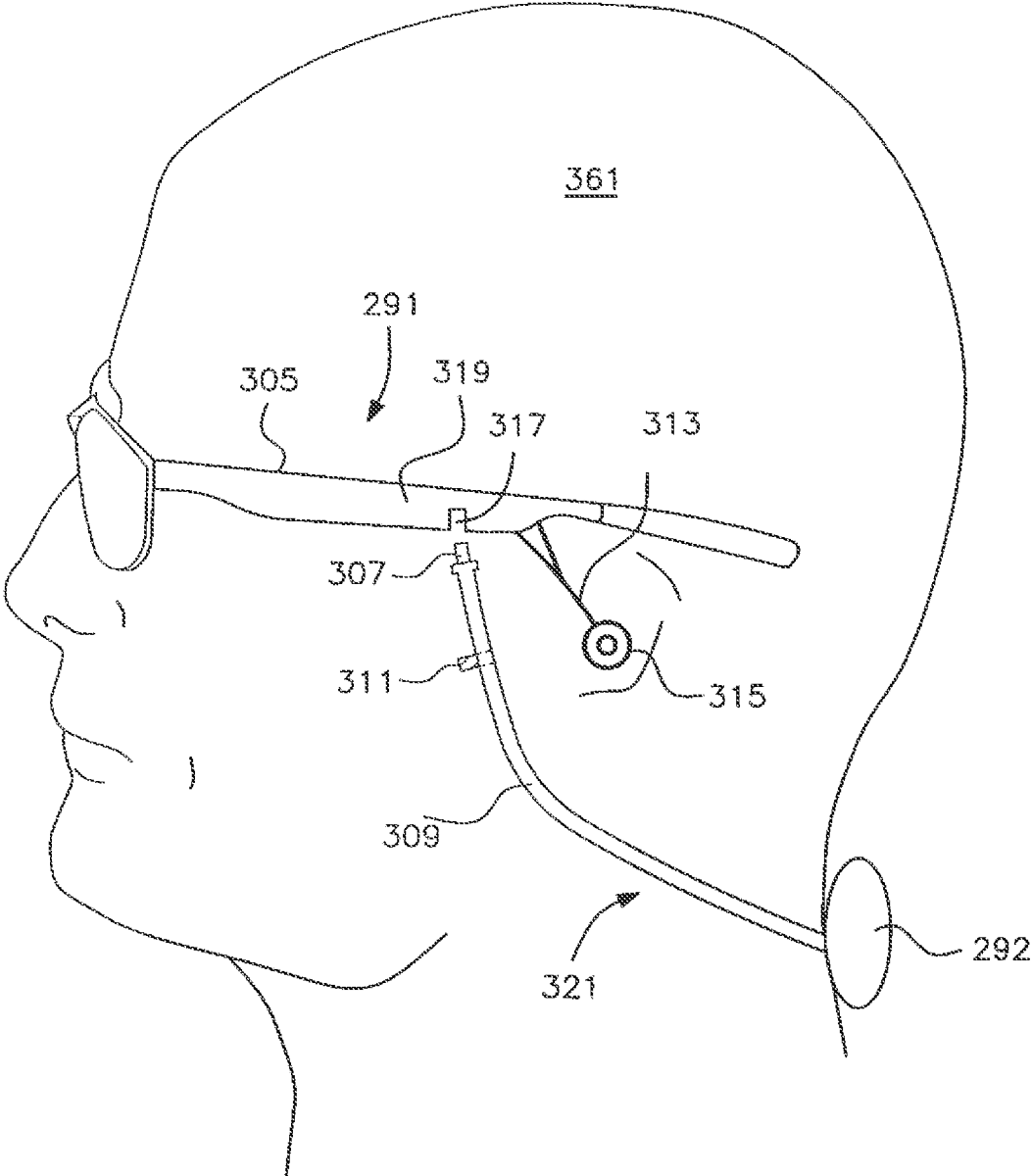

FIG. 7

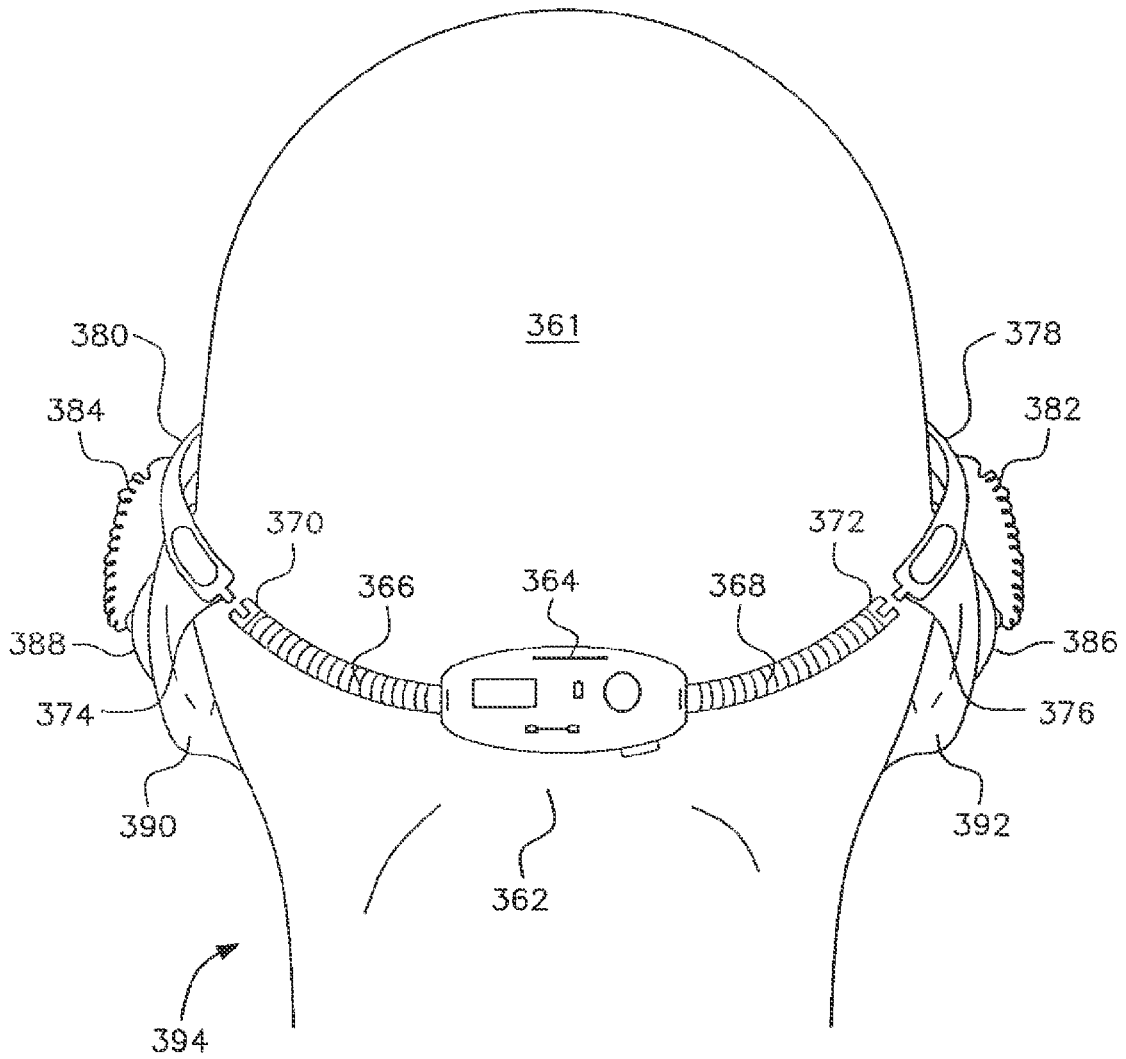

FIG. 8

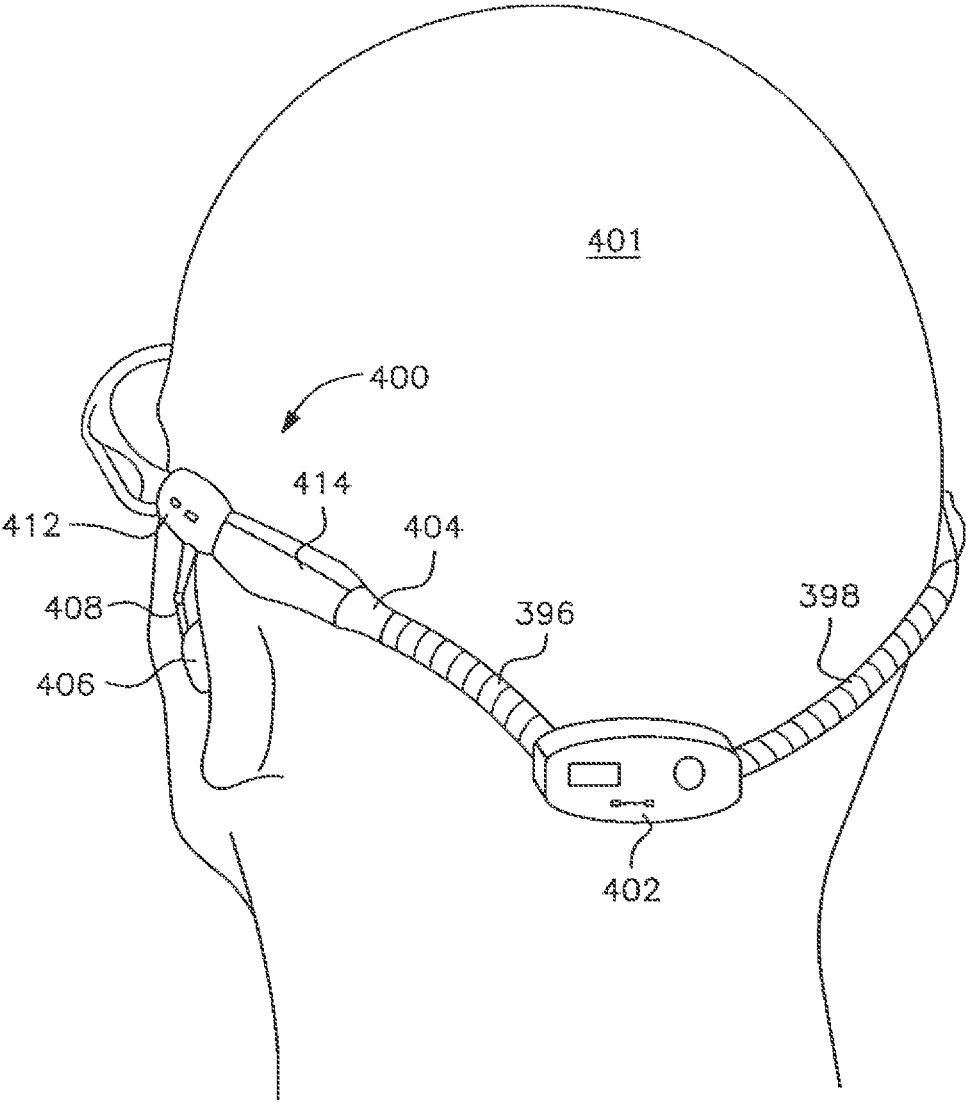

FIG. 9

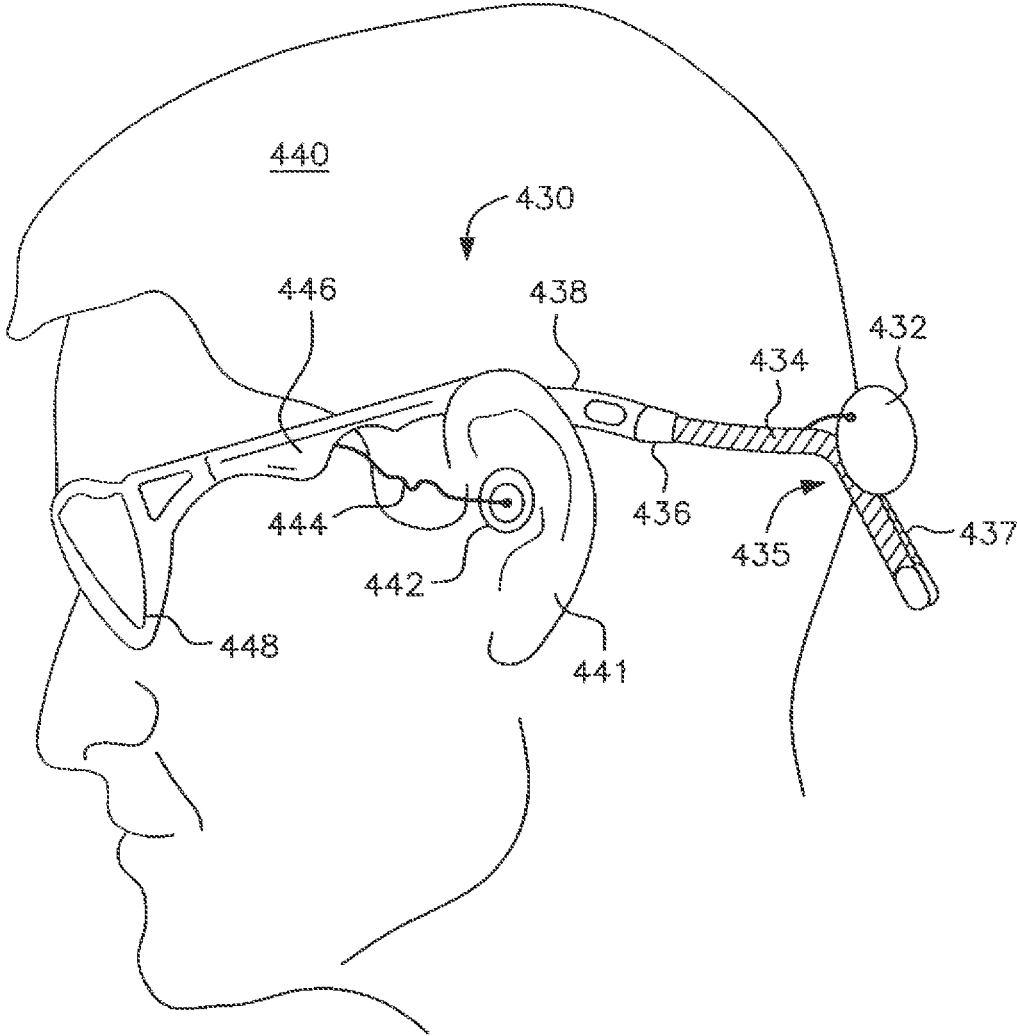

FIG. 10

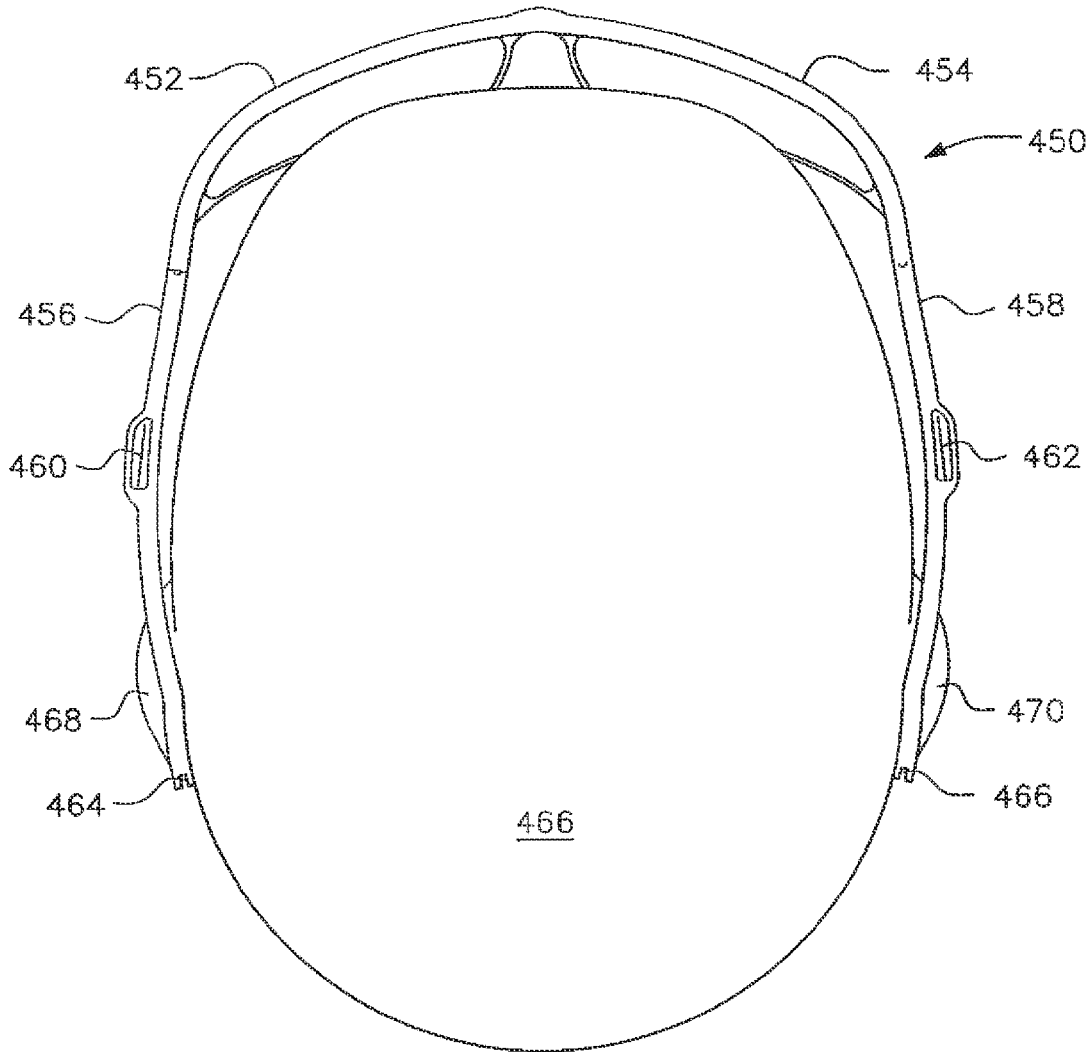

FIG. 10A

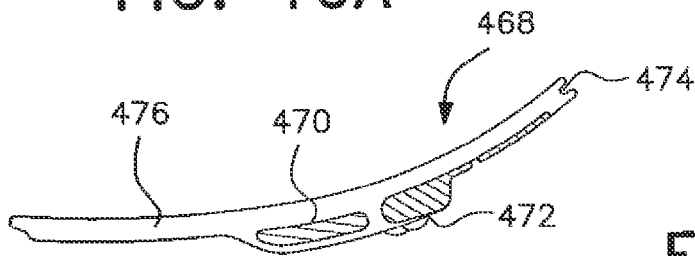

FIG. 10B

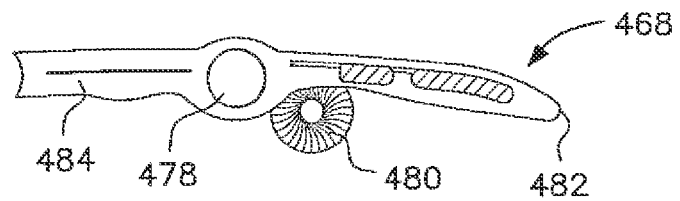

FIG. 11

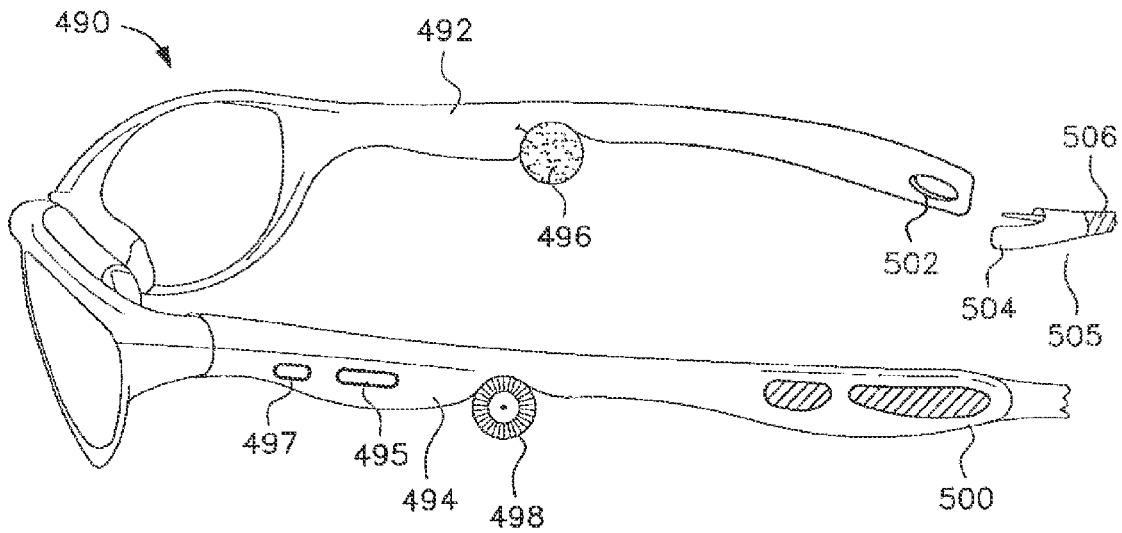

FIG. 11A

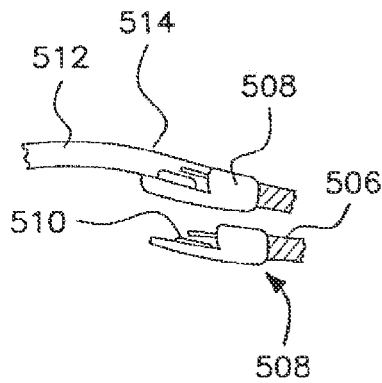

FIG. 12

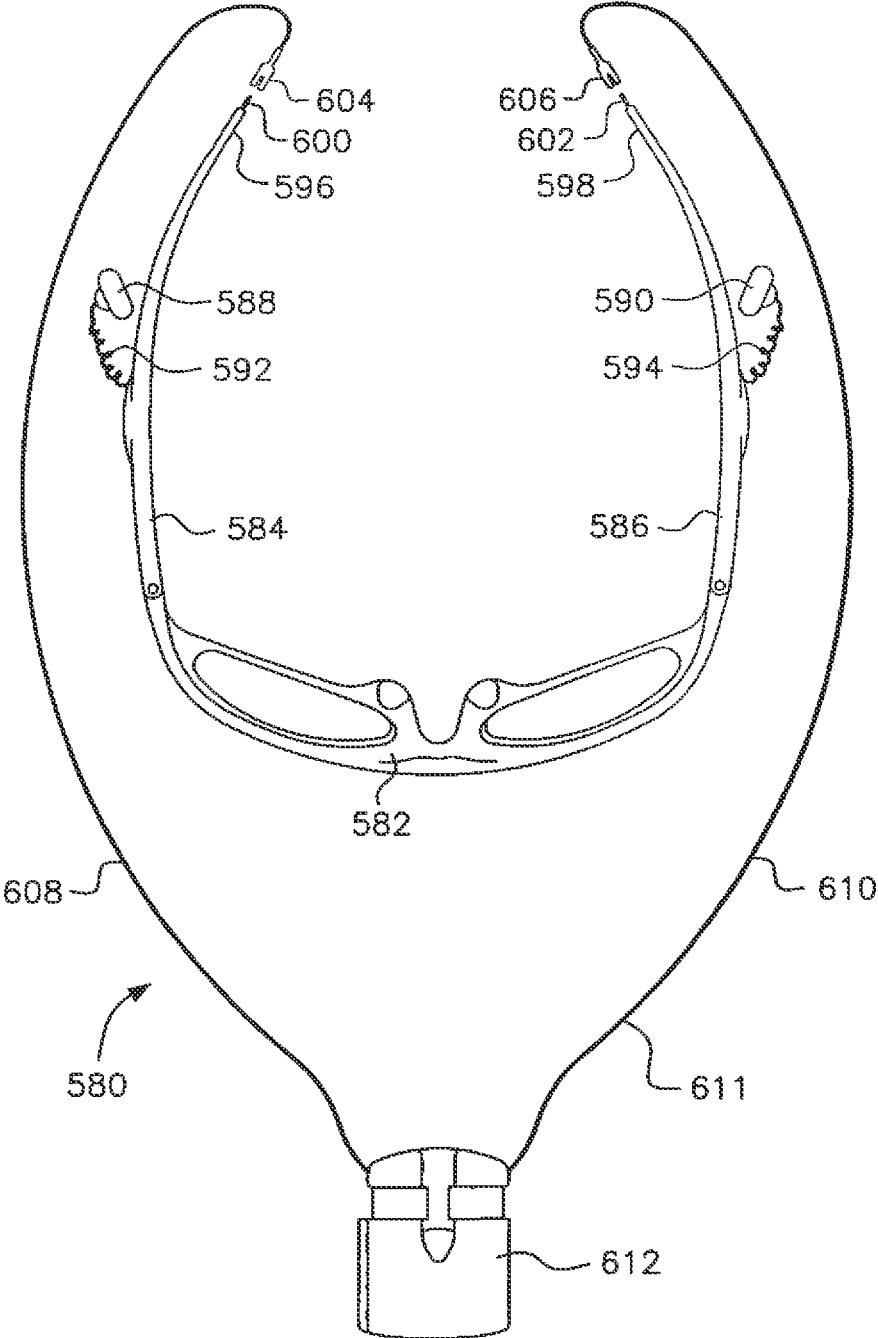

FIG. 12A

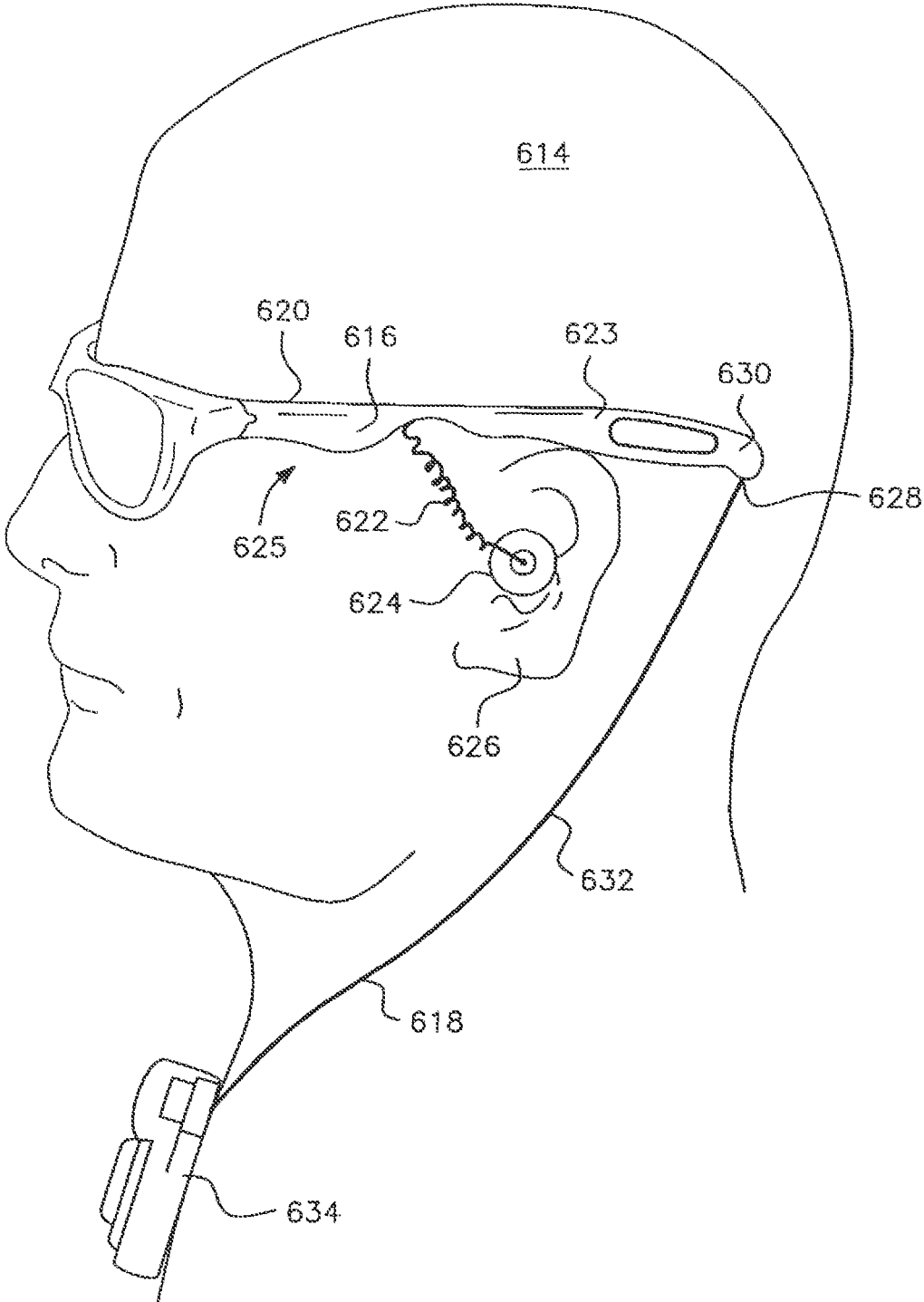

FIG. 12B

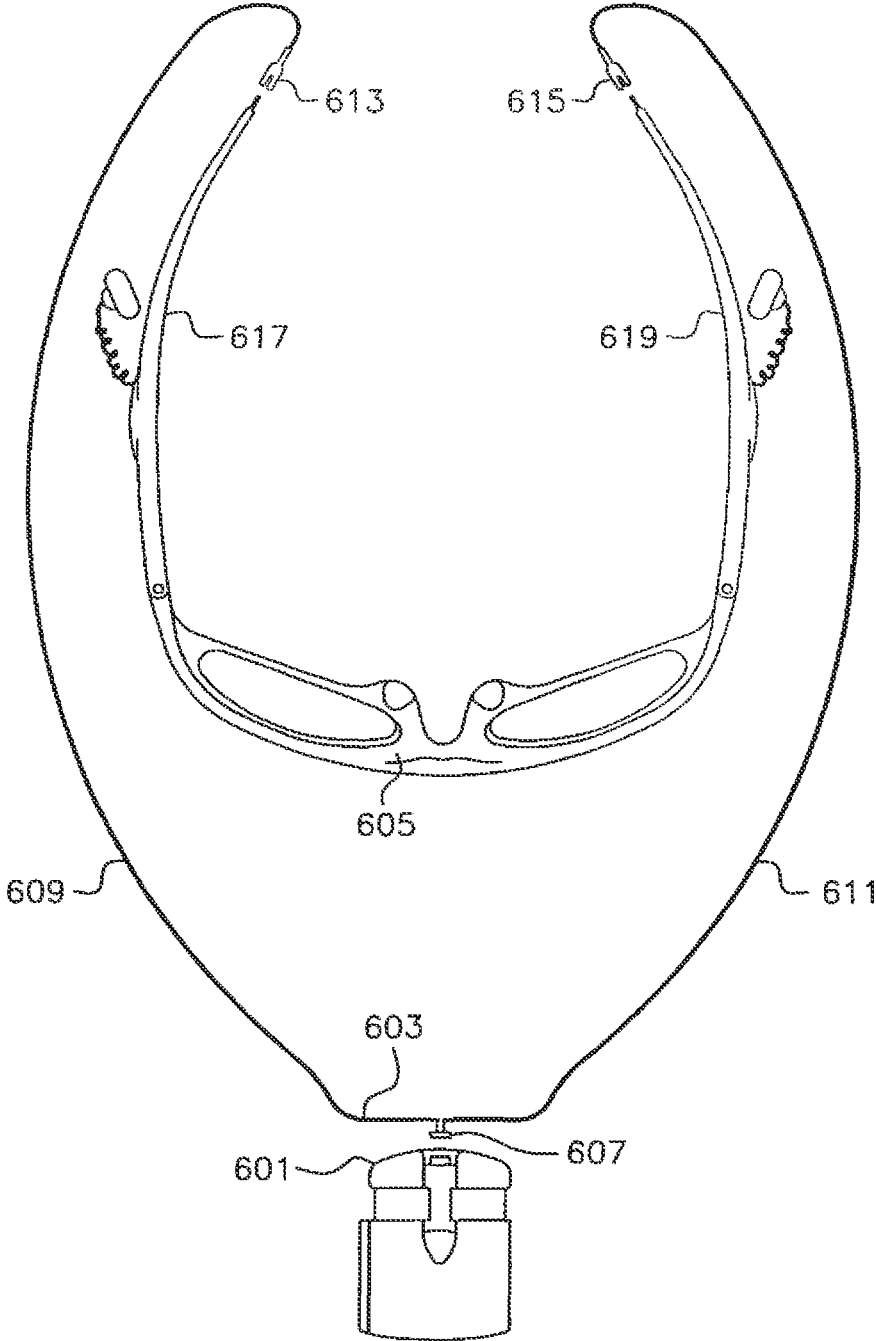

FIG. 13

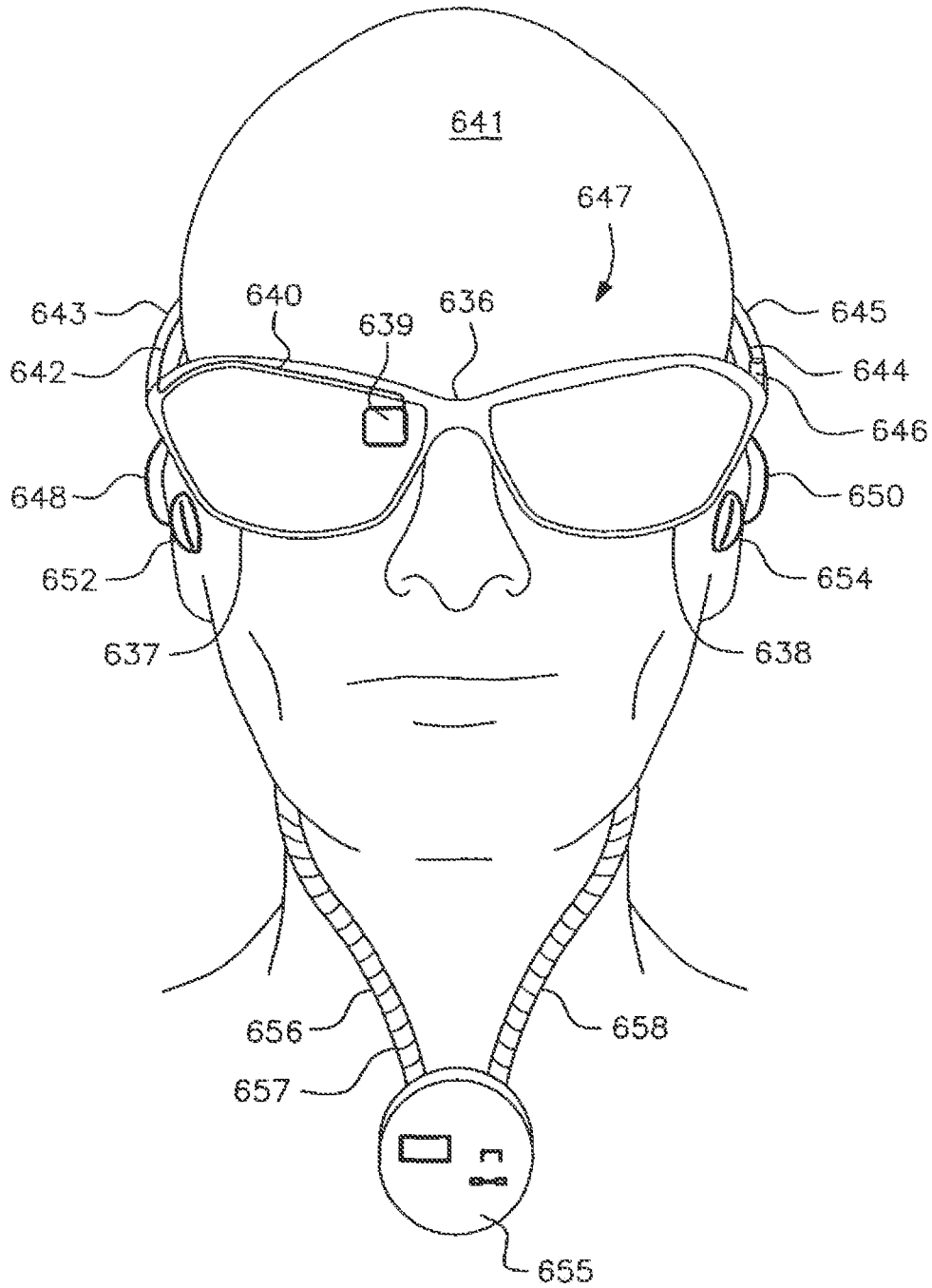

FIG. 14A

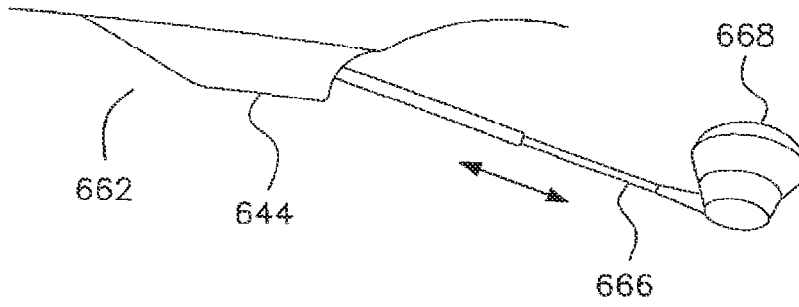

FIG. 14B

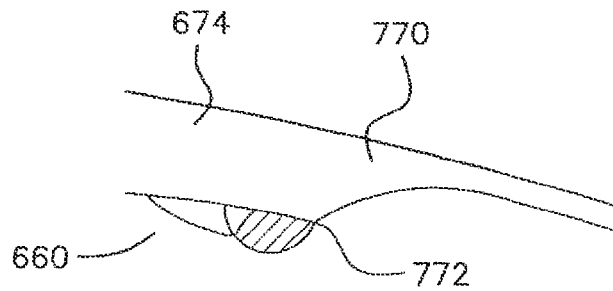

FIG. 14C

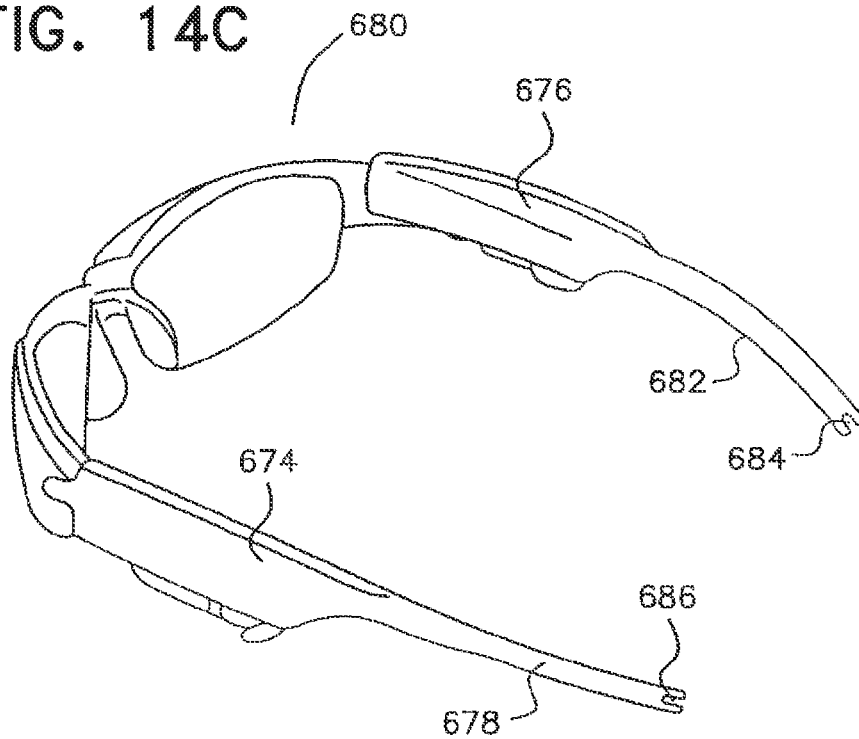

FIG. 14D

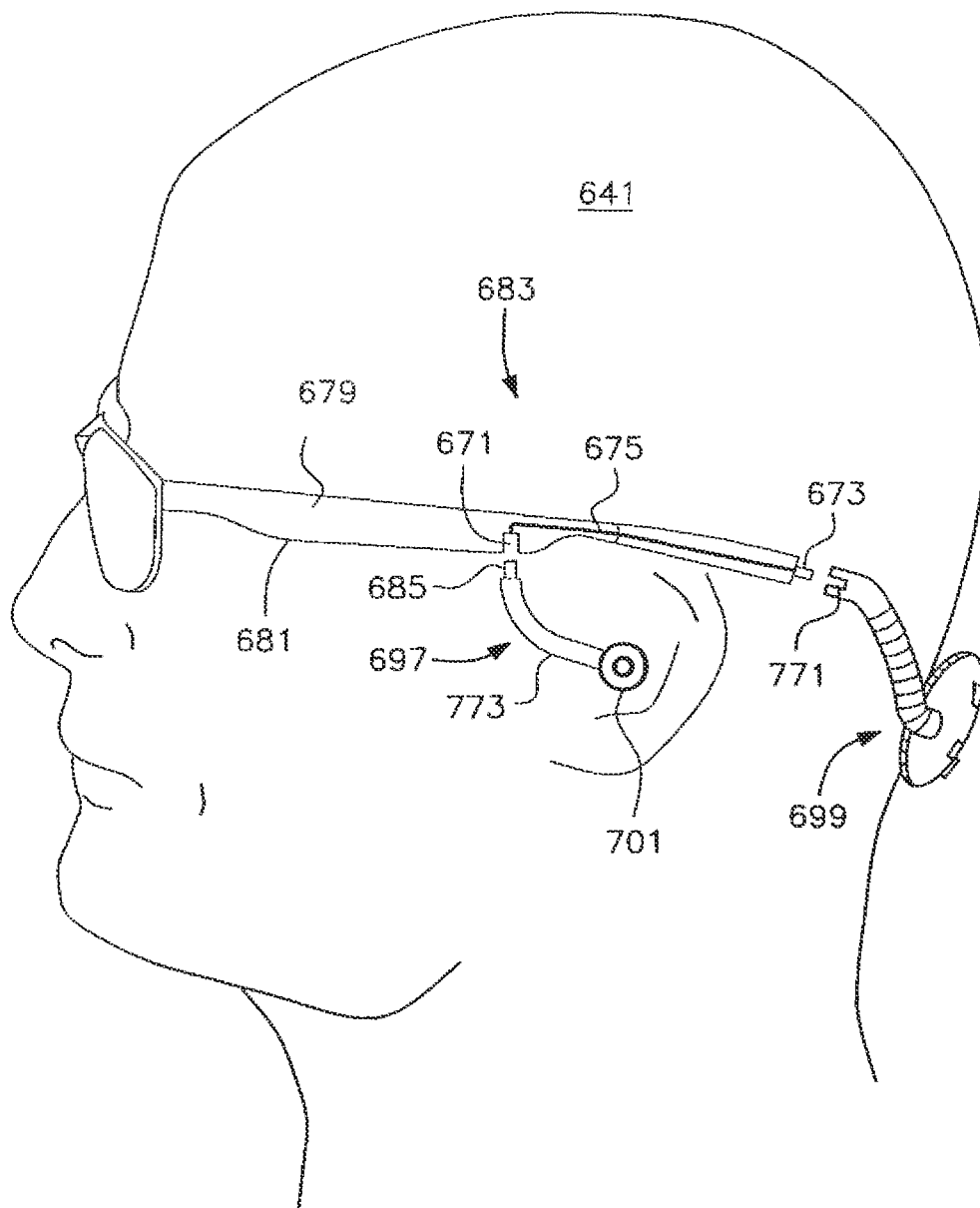

FIG. 15A

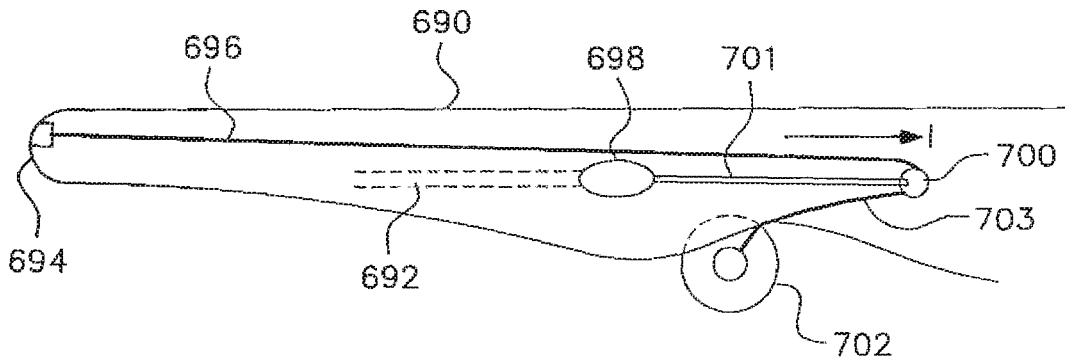

FIG. 15B

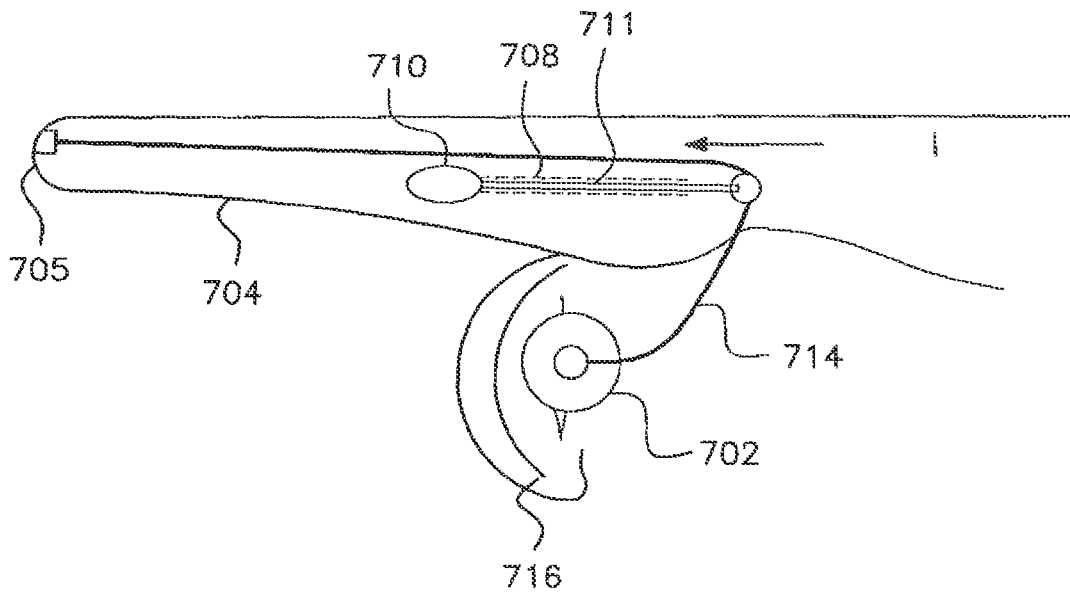

FIG. 16A

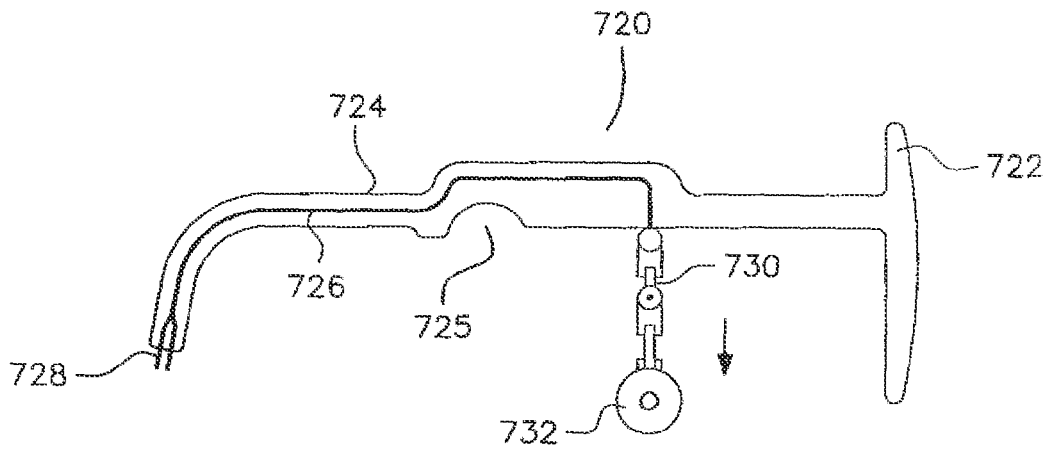

FIG. 16B

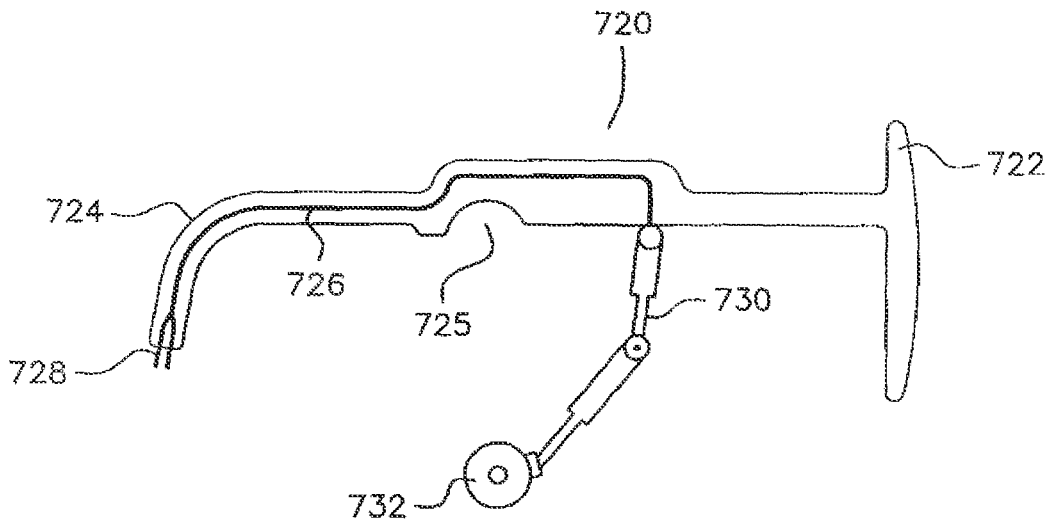

FIG. 16C

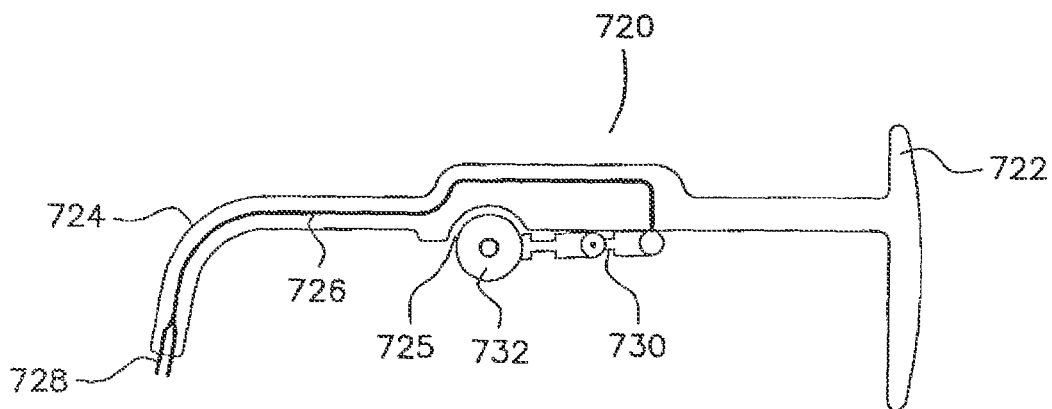

FIG. 17A

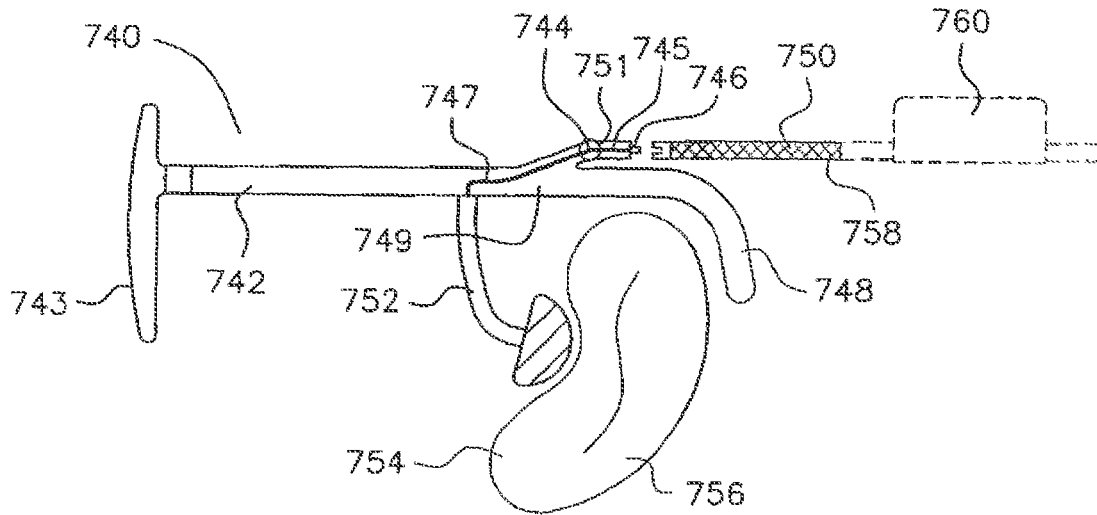

FIG. 17B

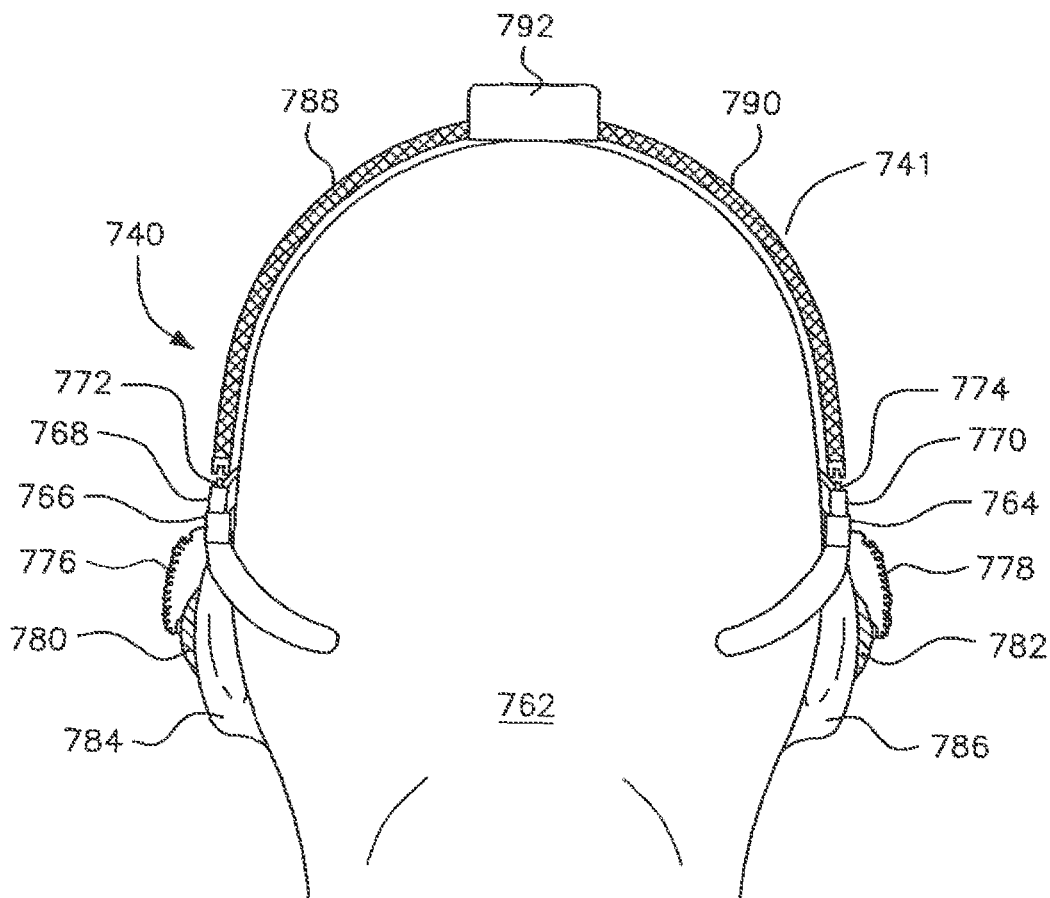

FIG. 18A

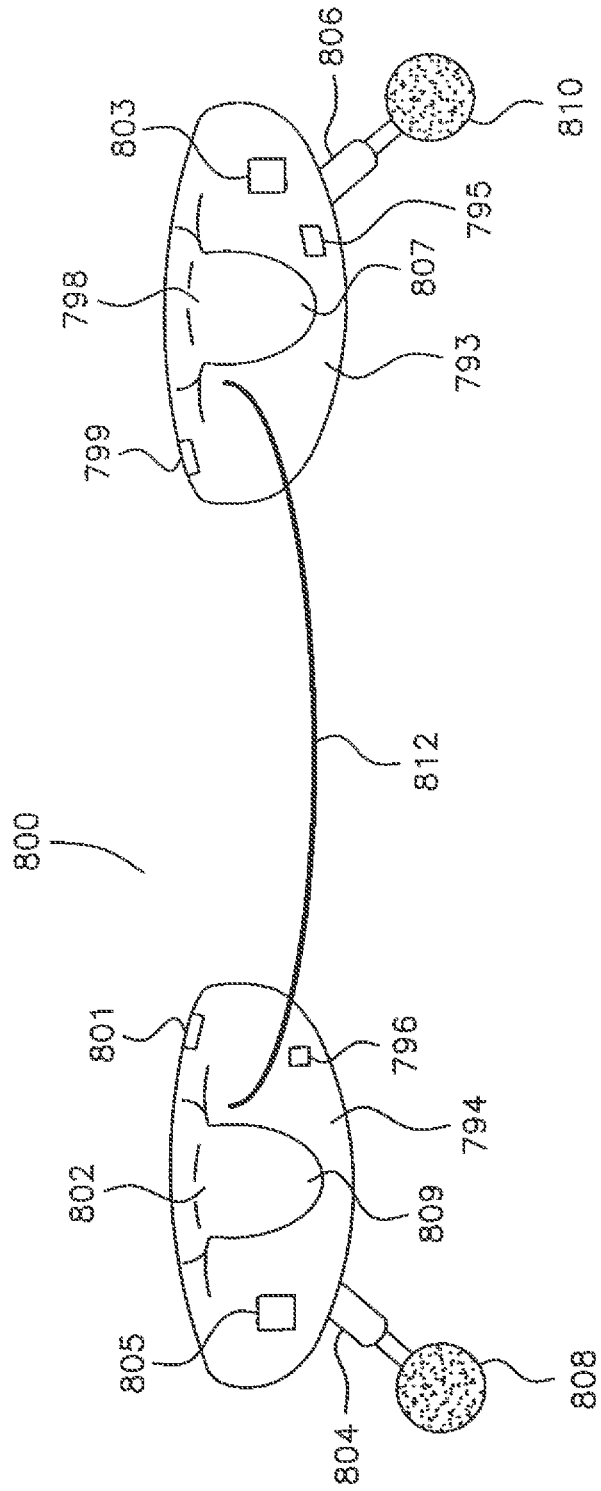

FIG. 18B

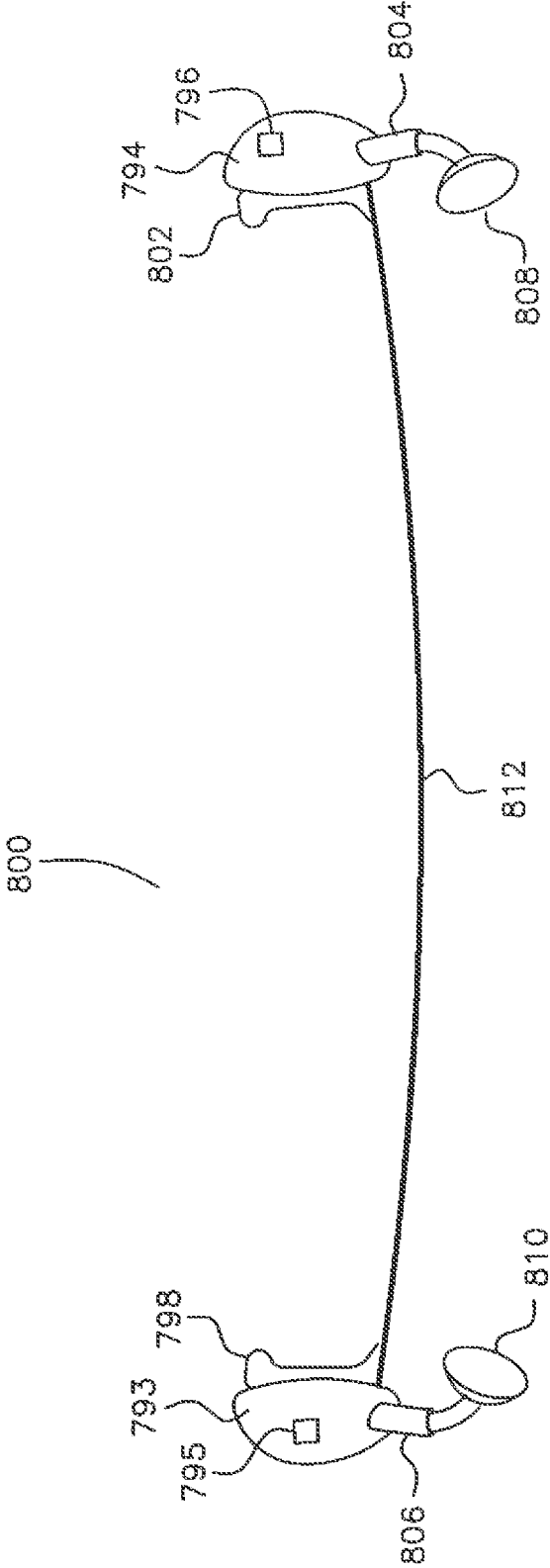

FIG. 19A

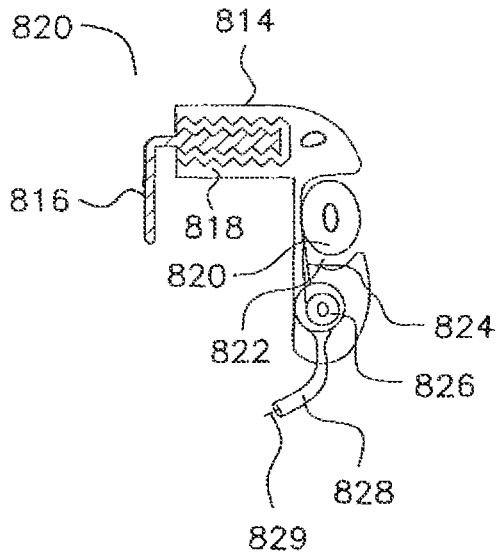

FIG. 19B

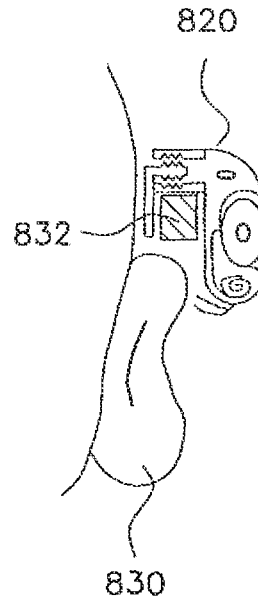

FIG. 20

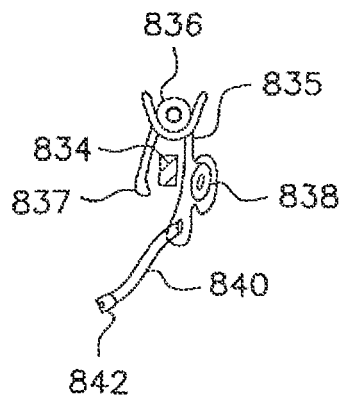

FIG. 21

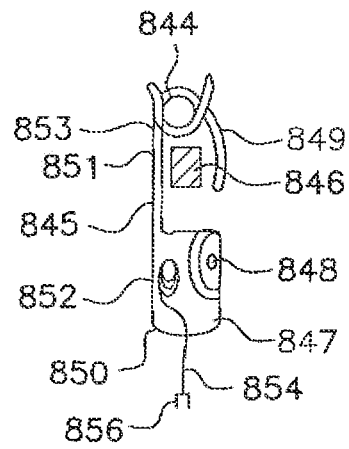

FIG. 22A

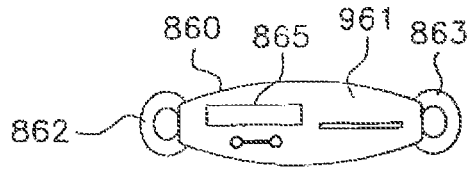

FIG. 22B

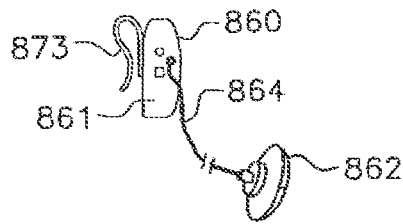

FIG. 22C

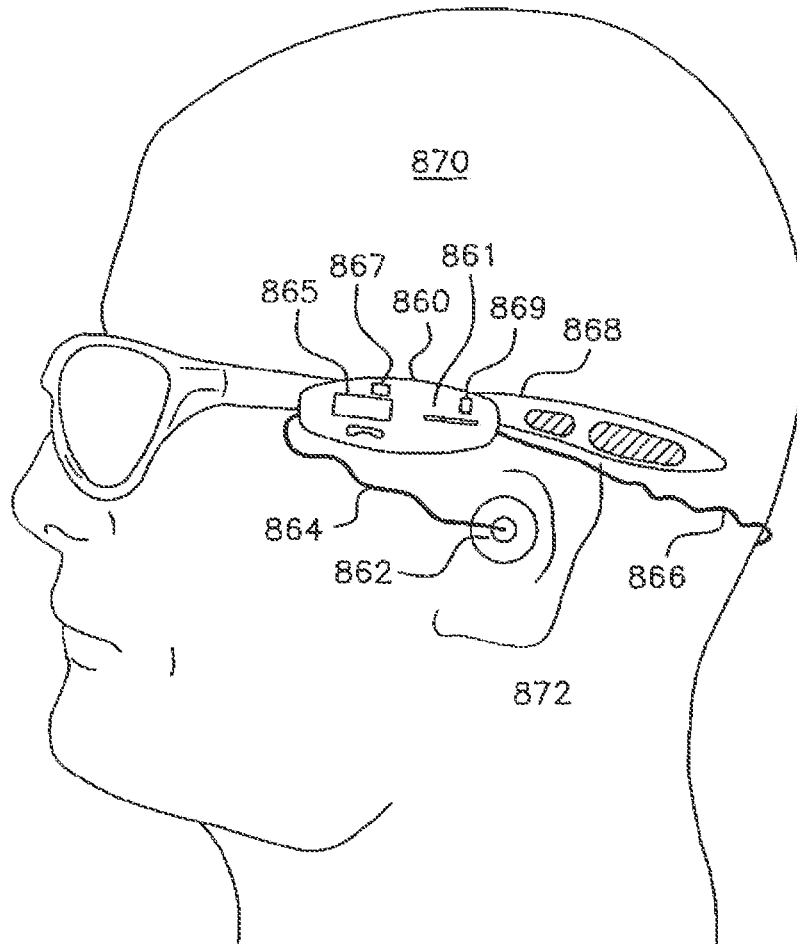

FIG. 23

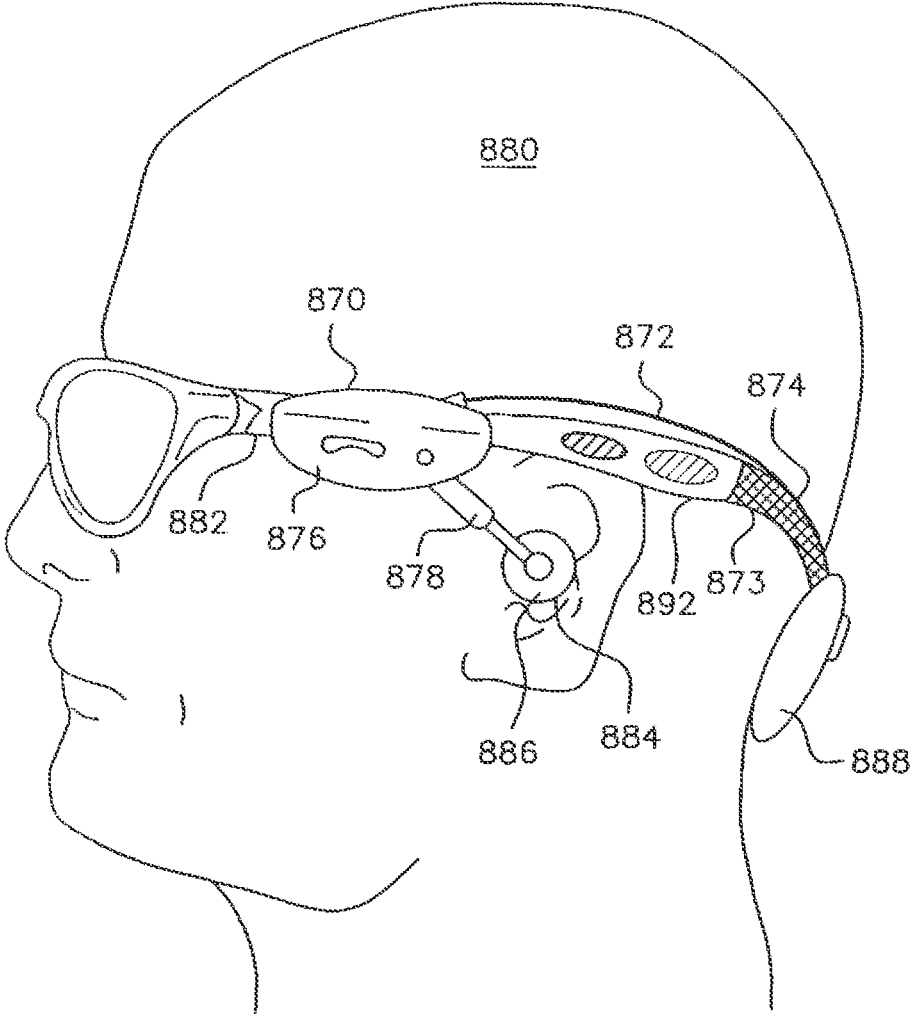

FIG. 23A

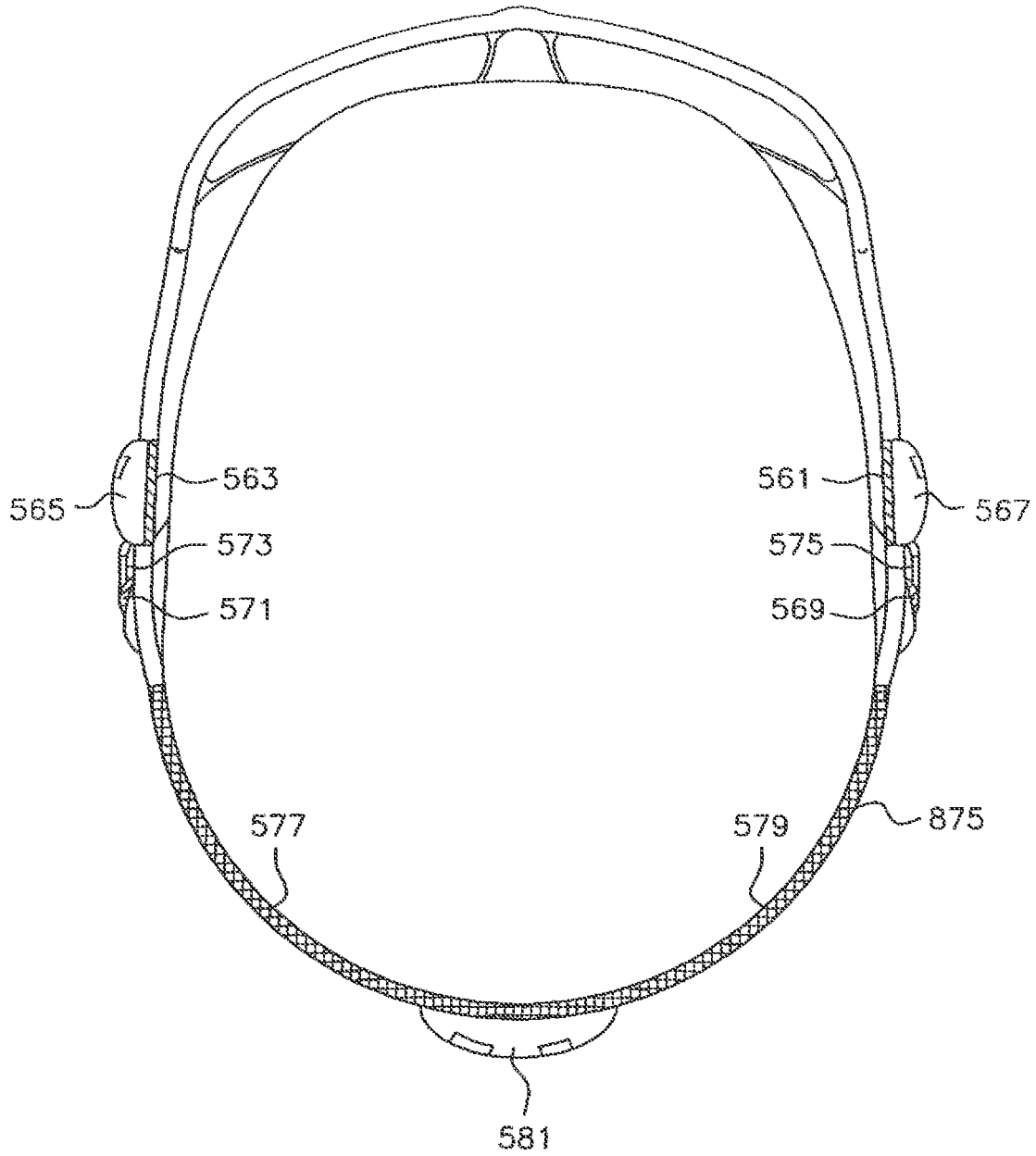

FIG. 23B

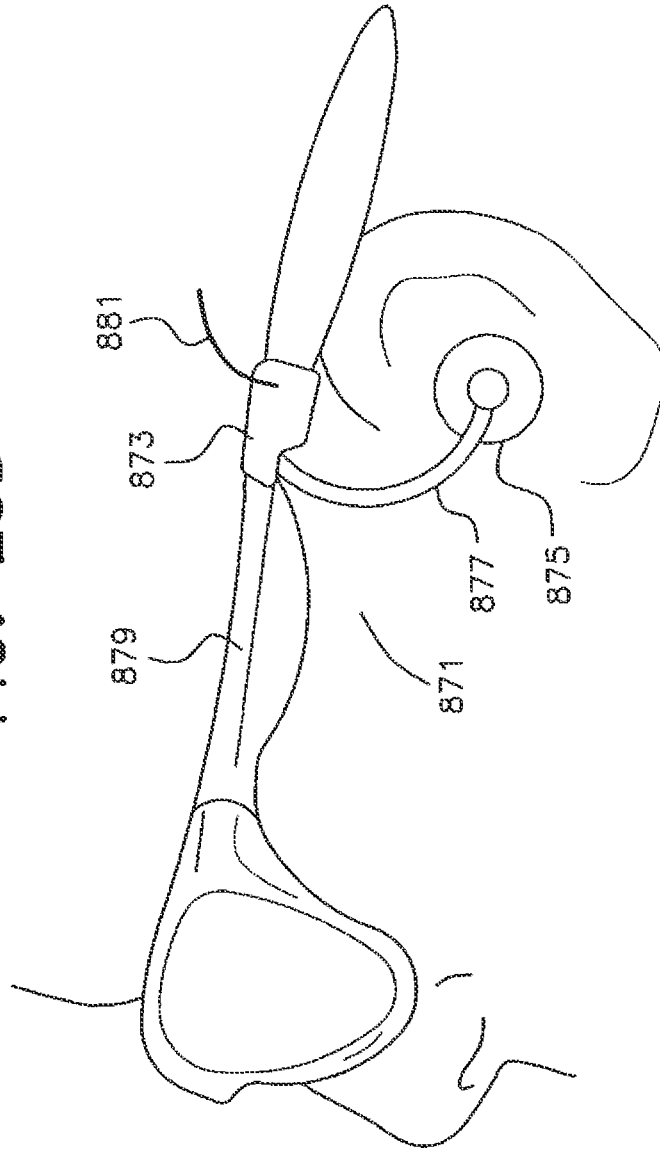

FIG. 23C

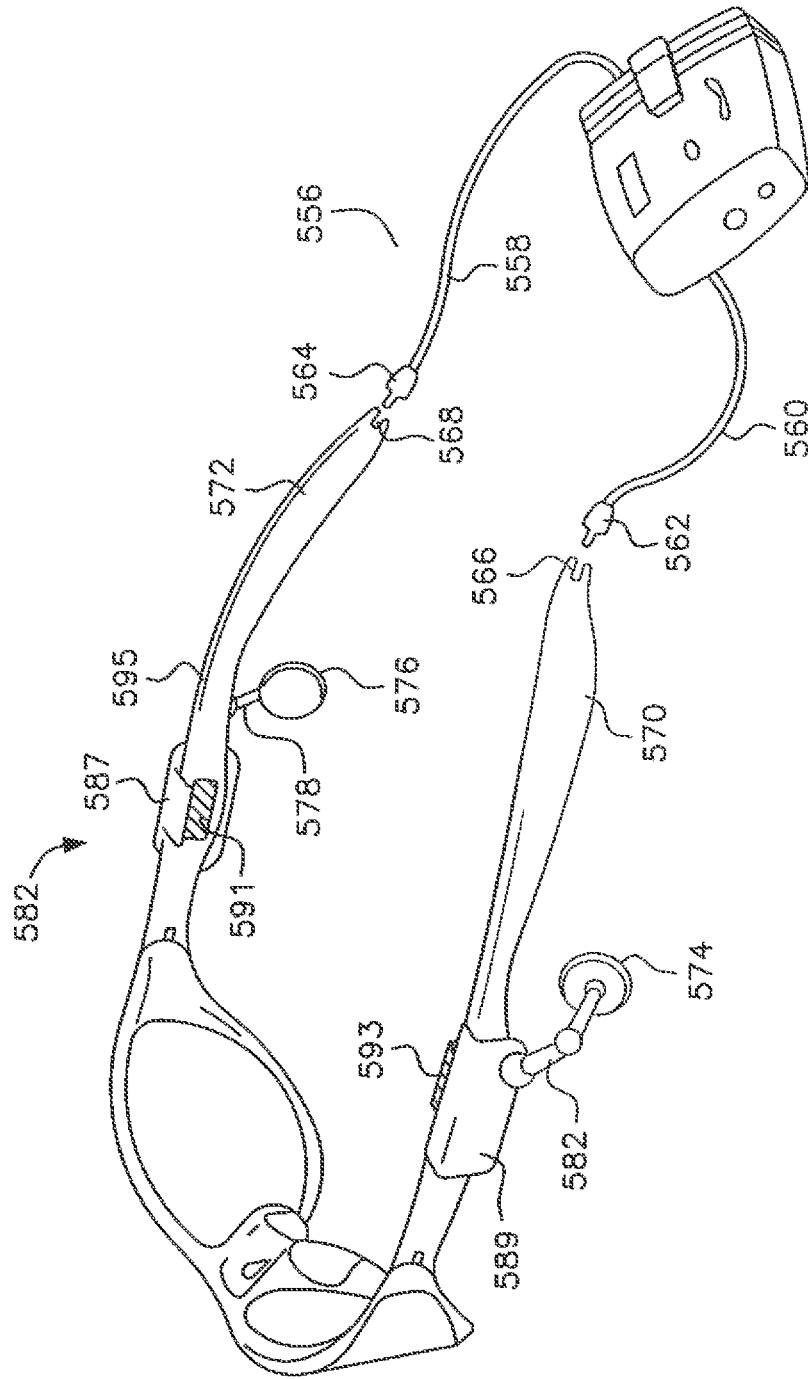

FIG. 24A

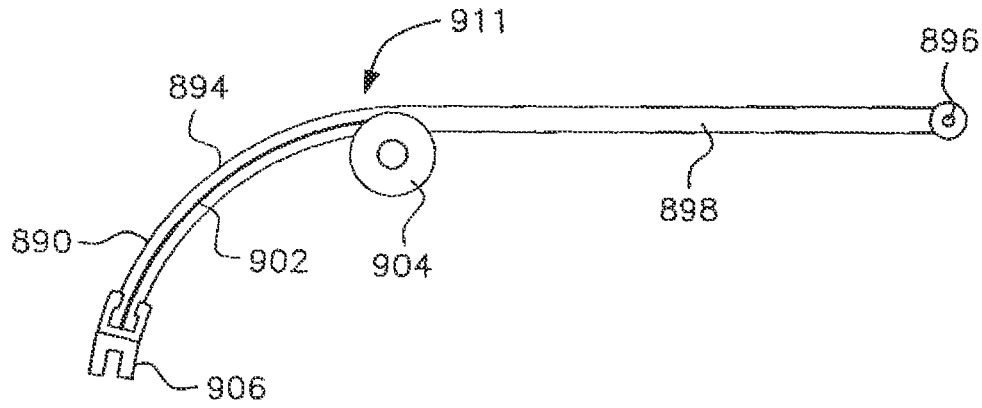

FIG. 24B

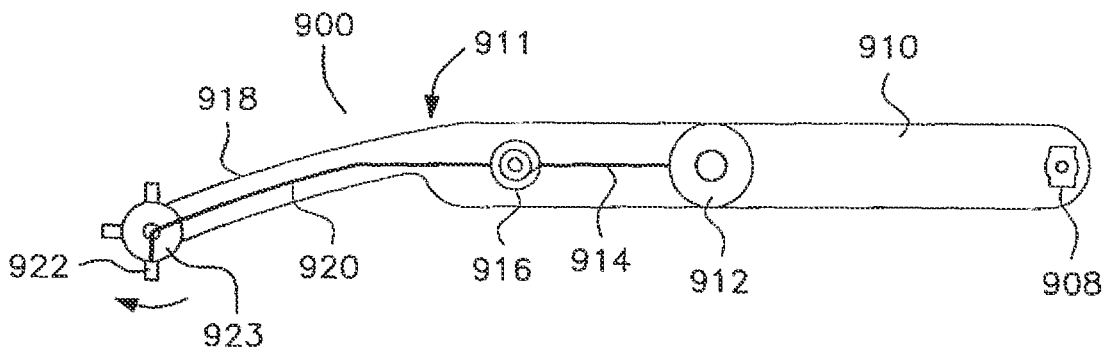

FIG. 24C

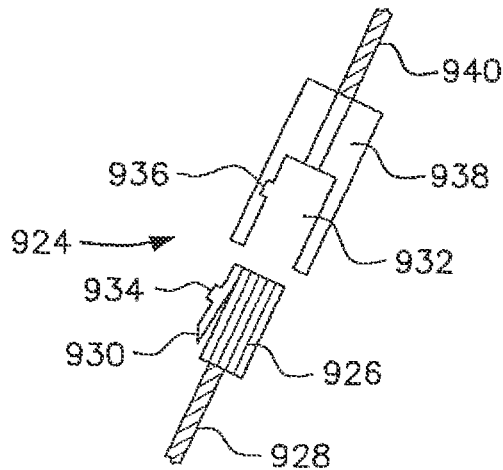

FIG. 24D

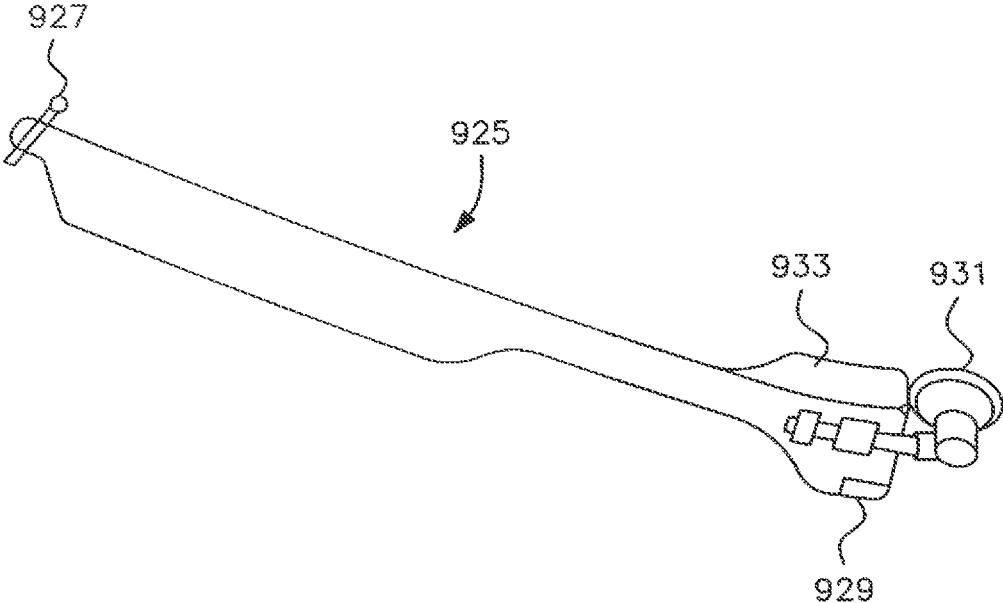

FIG. 25A

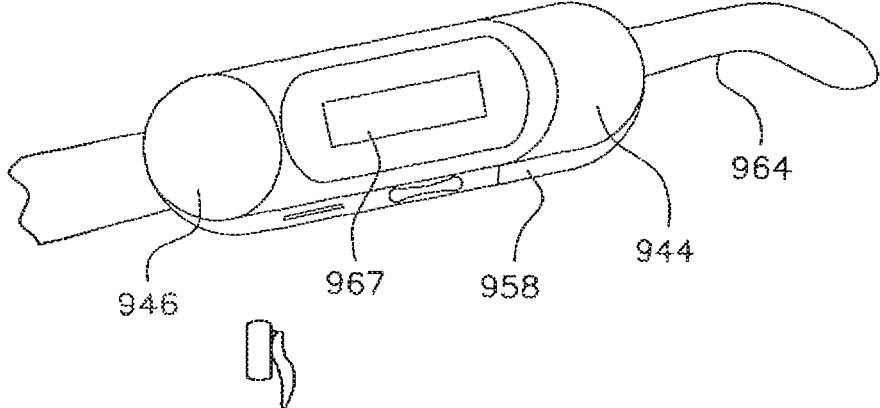

FIG. 25B

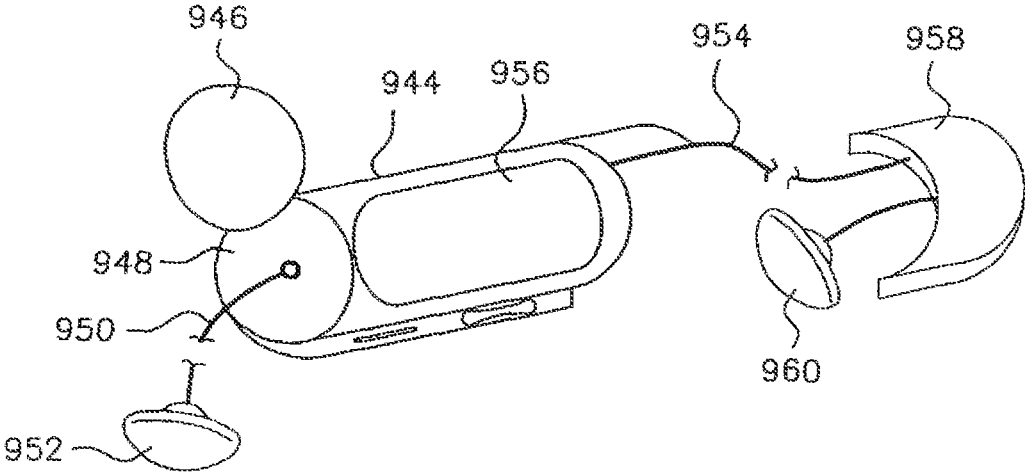

FIG. 25C

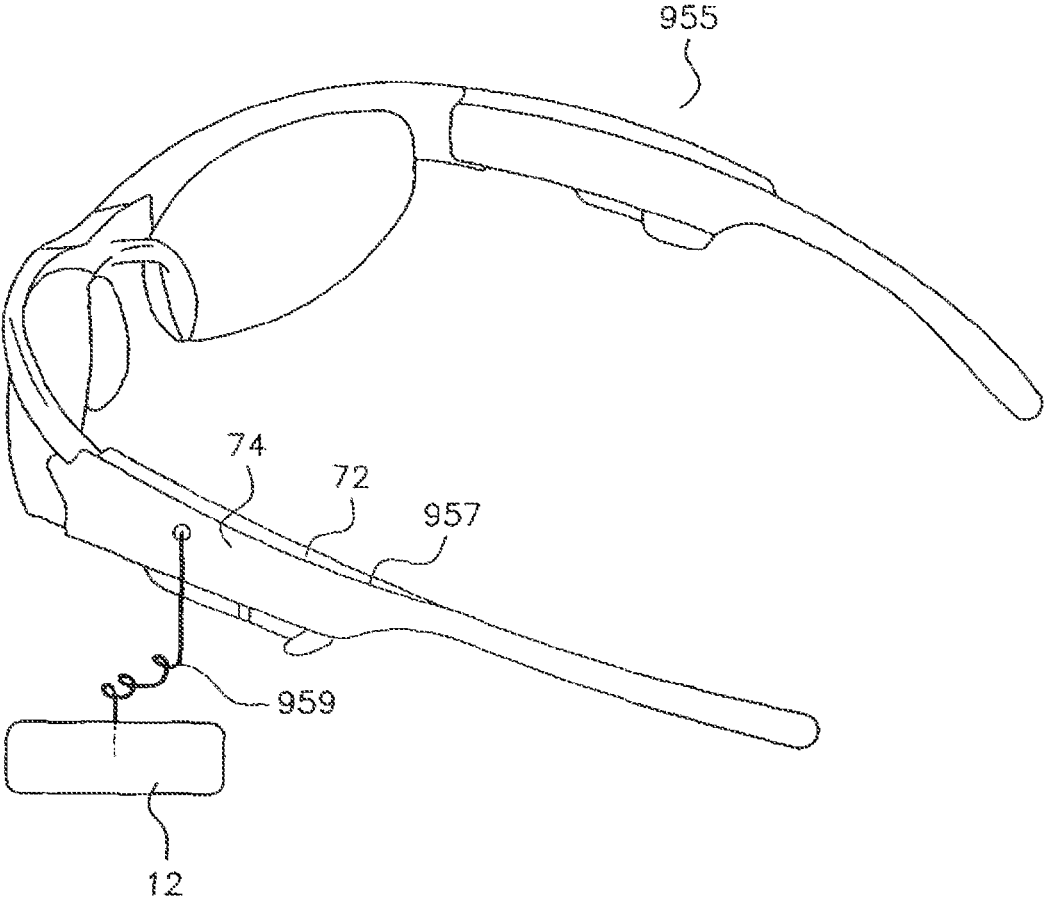

FIG. 26A

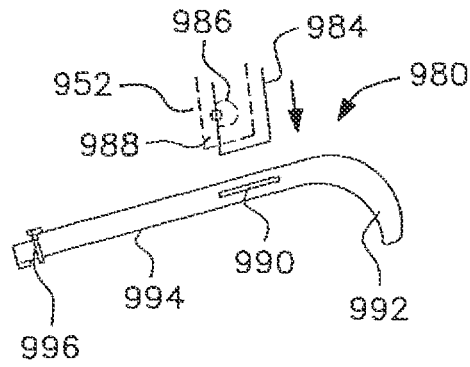

FIG. 26B

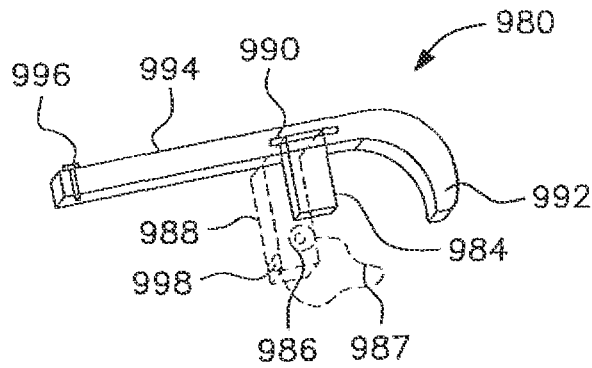

FIG. 26C

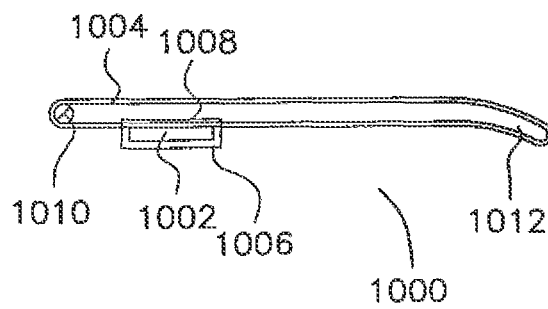

FIG. 27

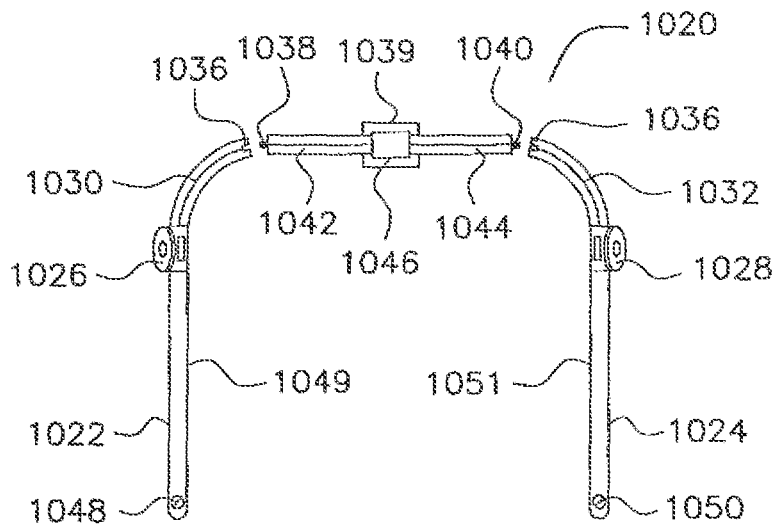

FIG. 28

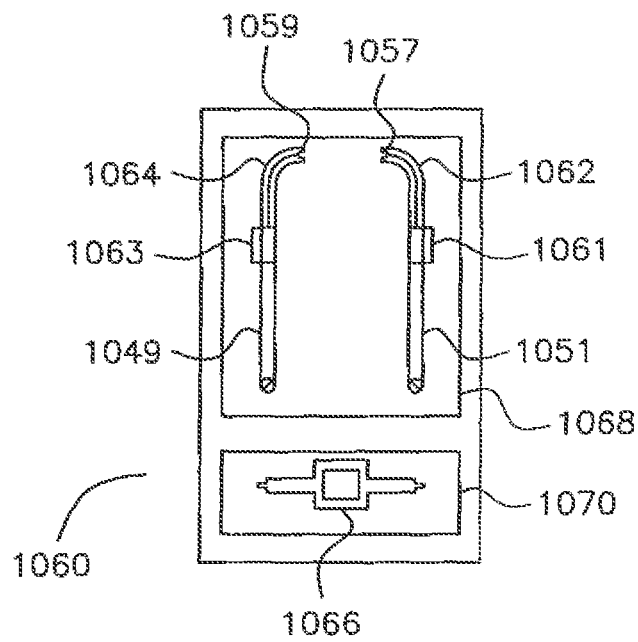

FIG. 29

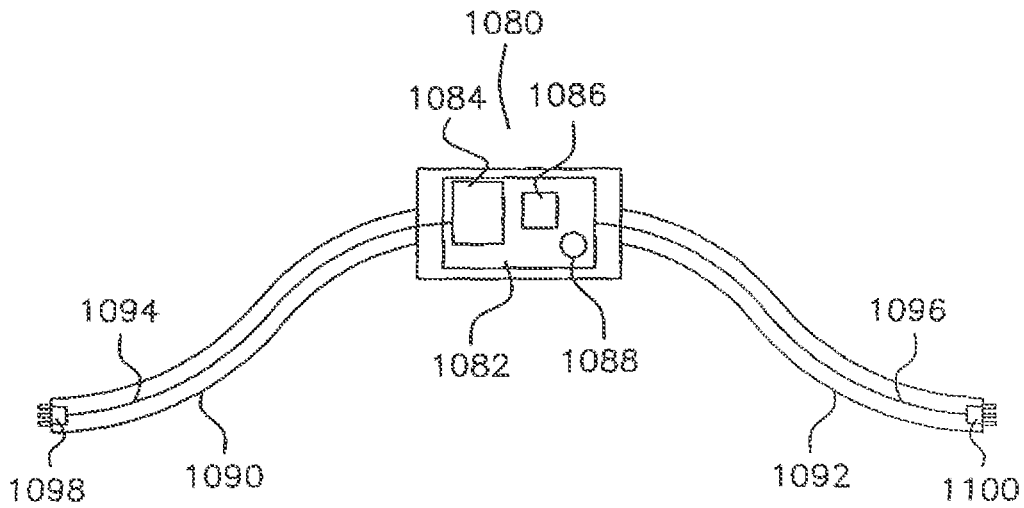

FIG. 30

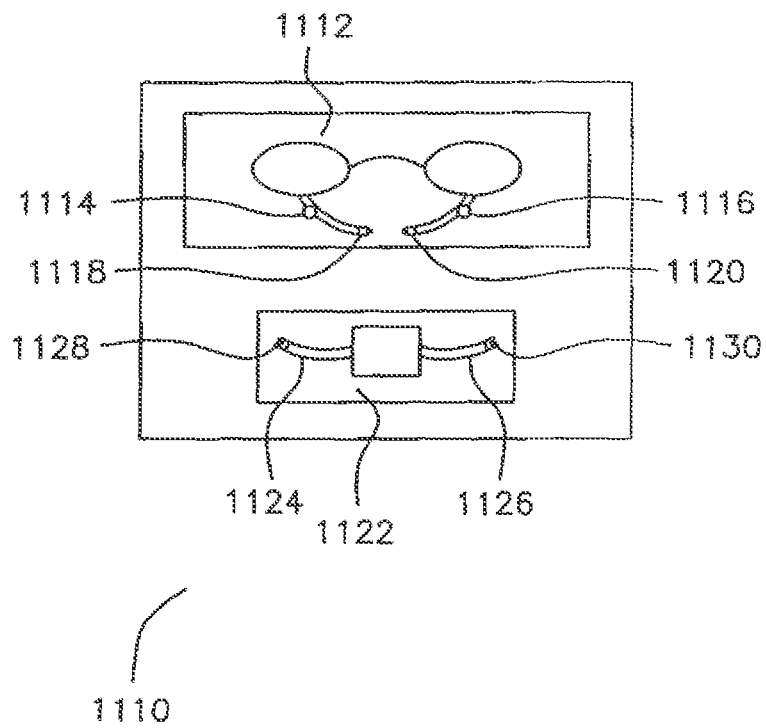

FIG. 30A

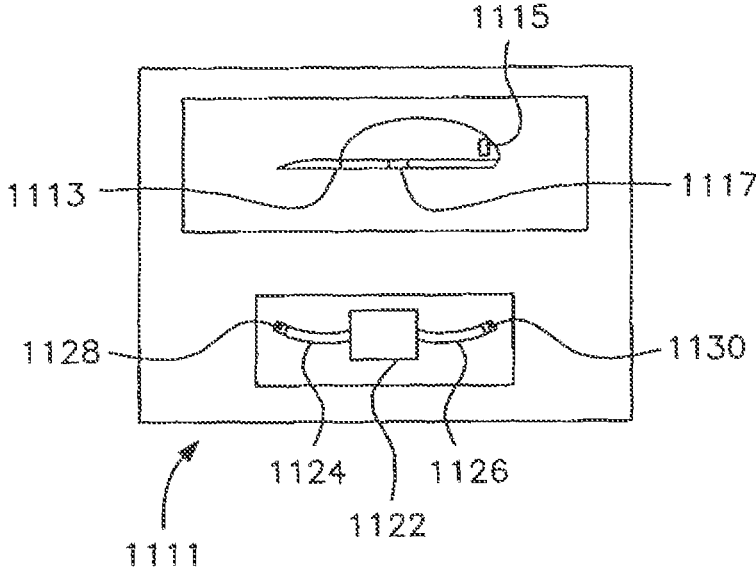

FIG. 31A

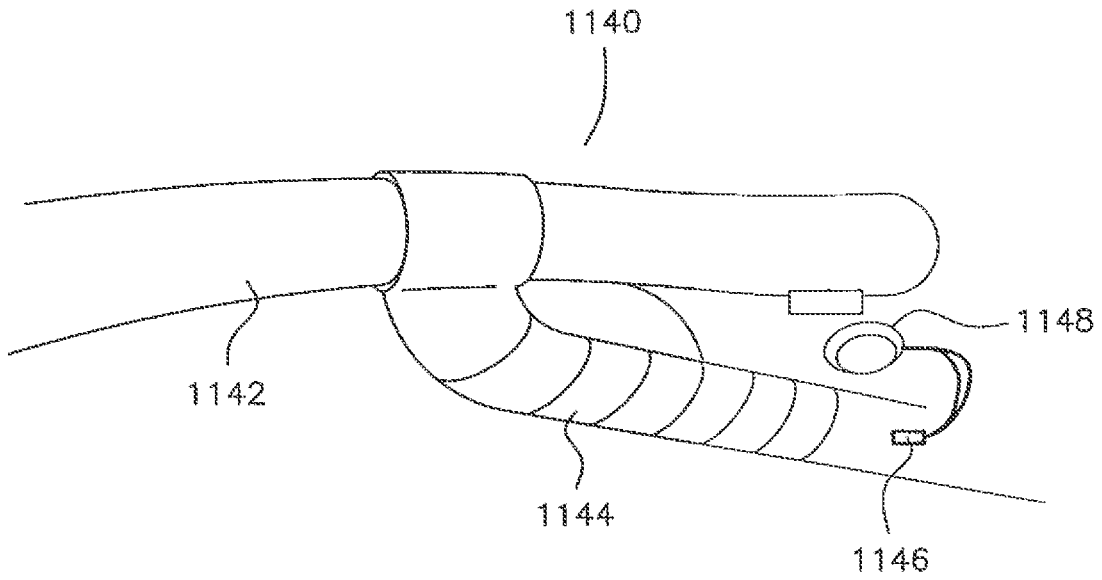

FIG. 31B

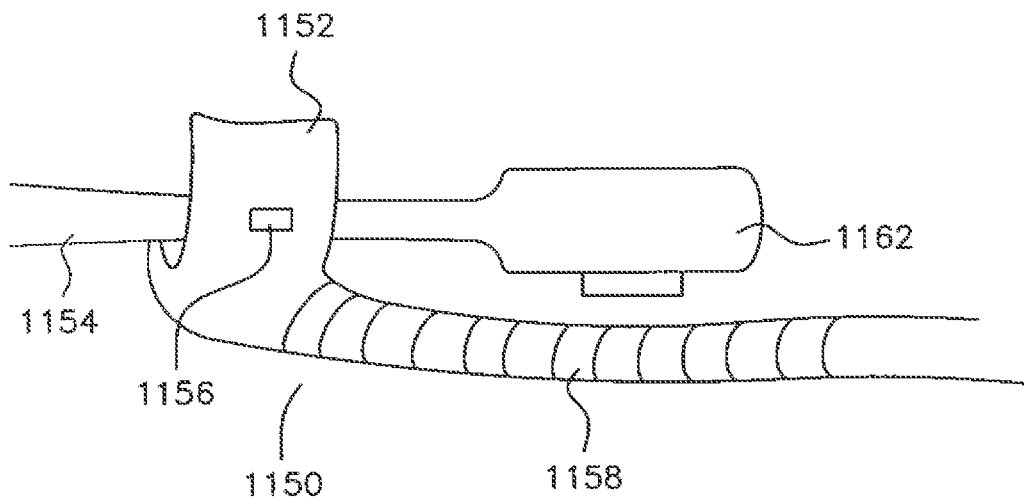

FIG. 32

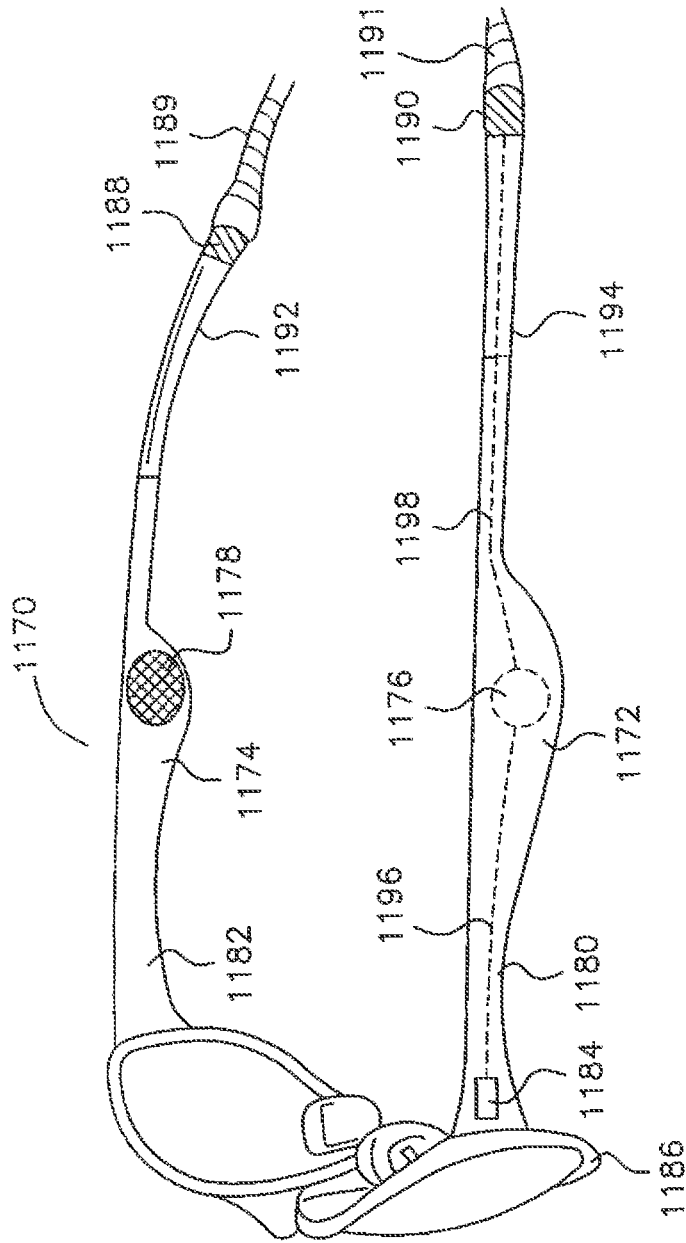

FIG. 32A

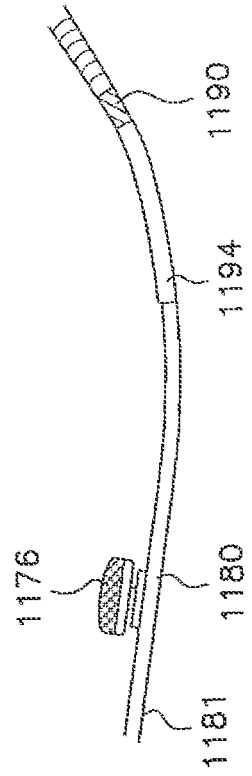

FIG. 33

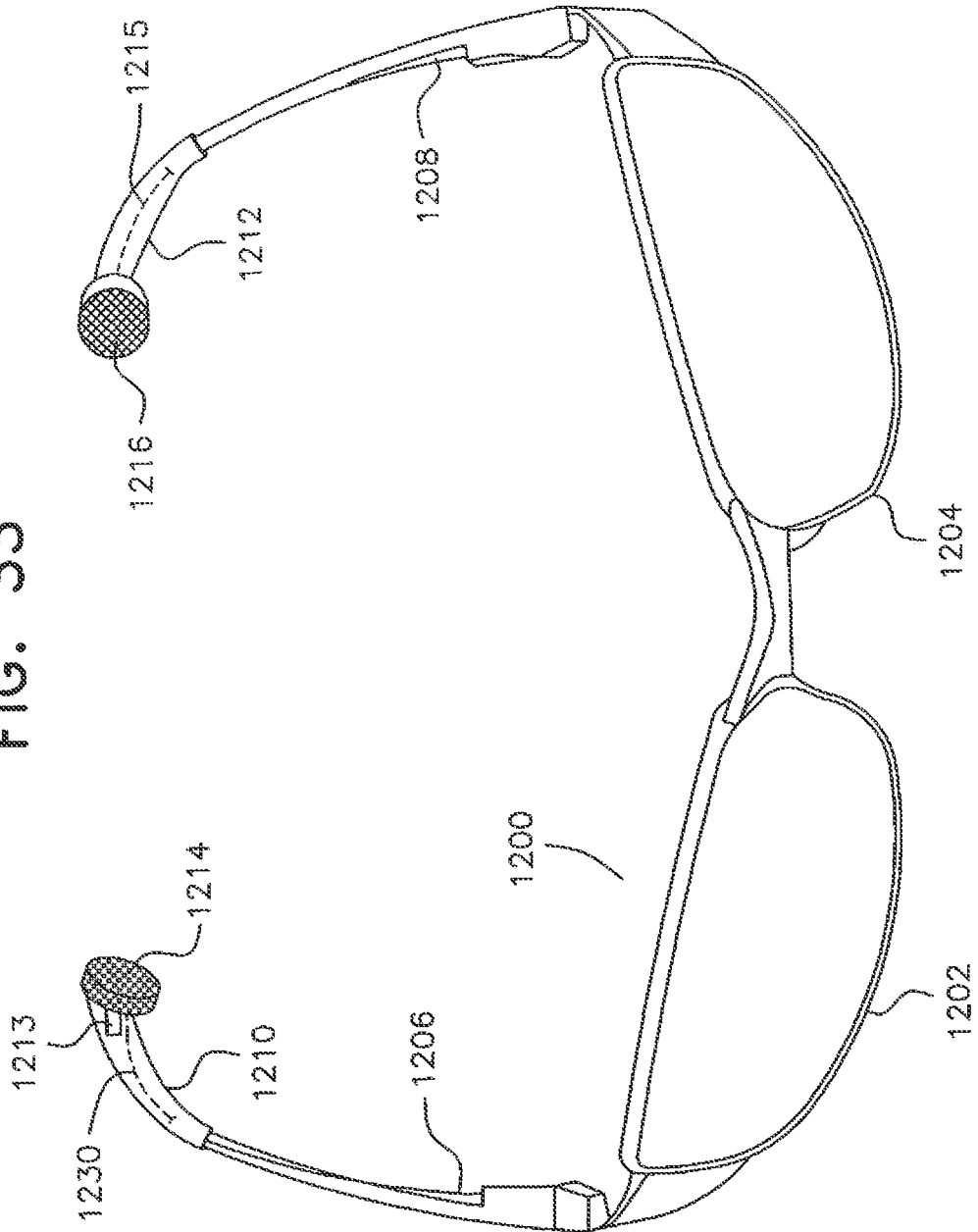

FIG. 33A

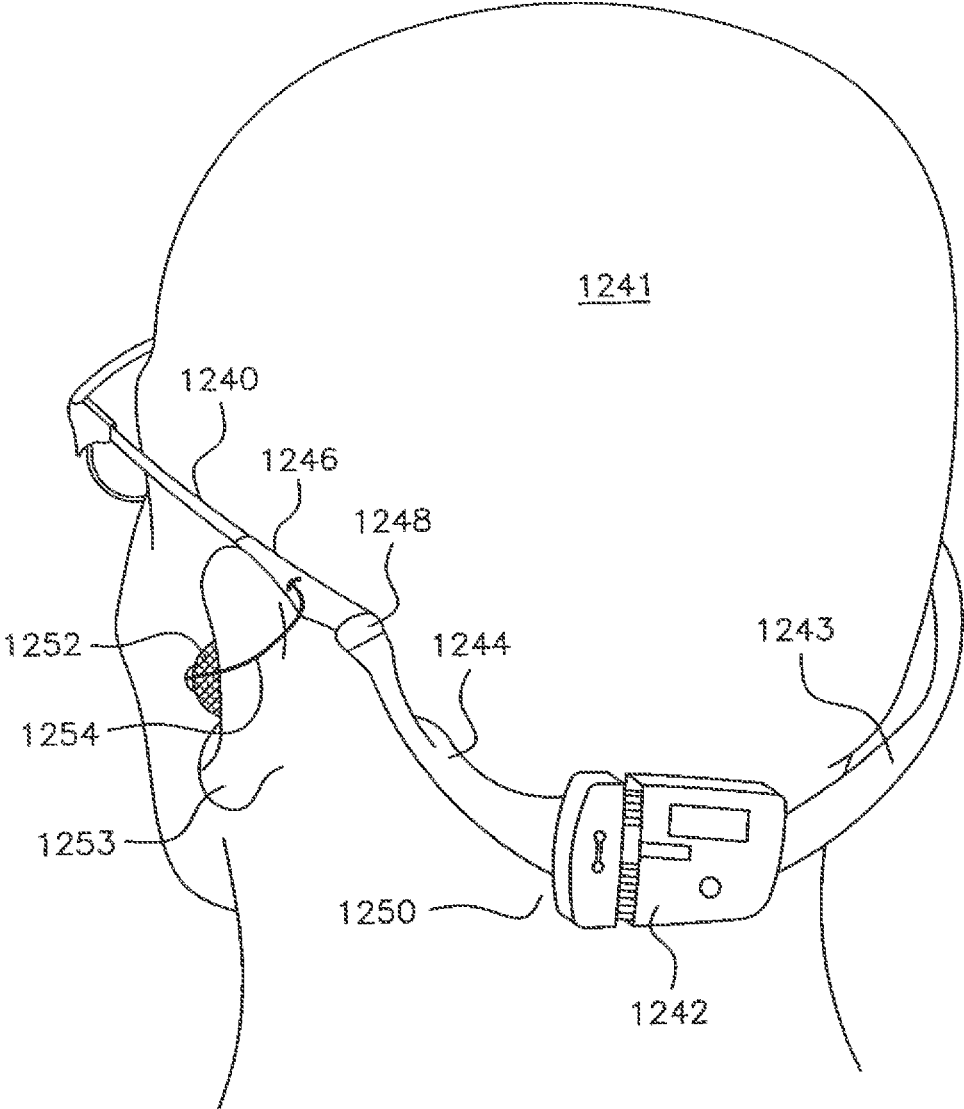

FIG. 34

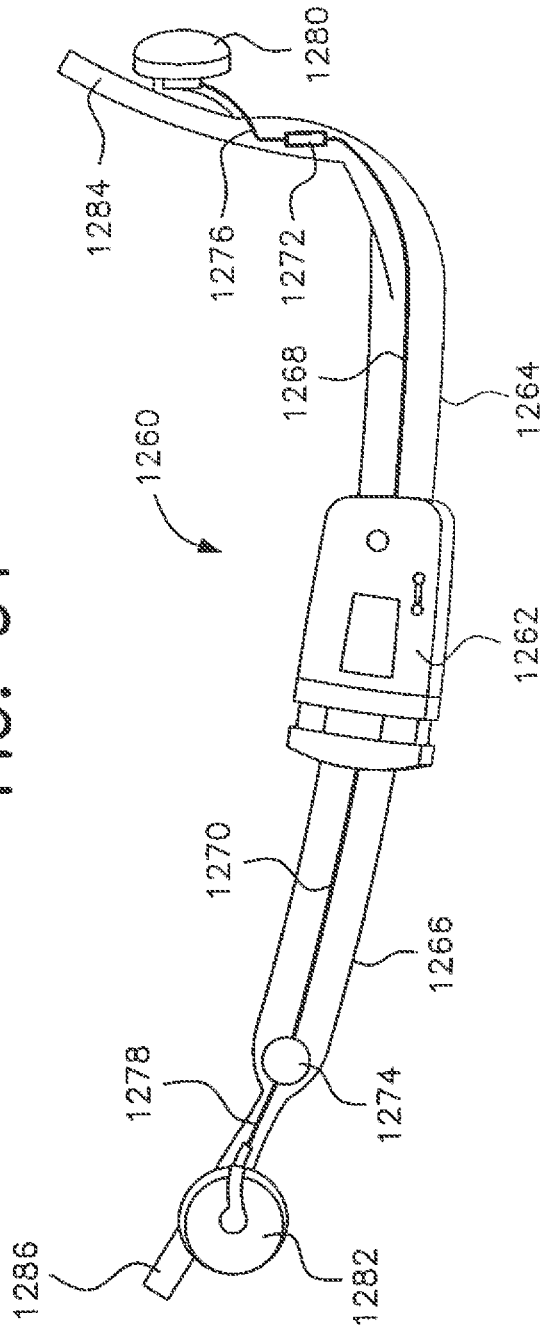

FIG. 34A

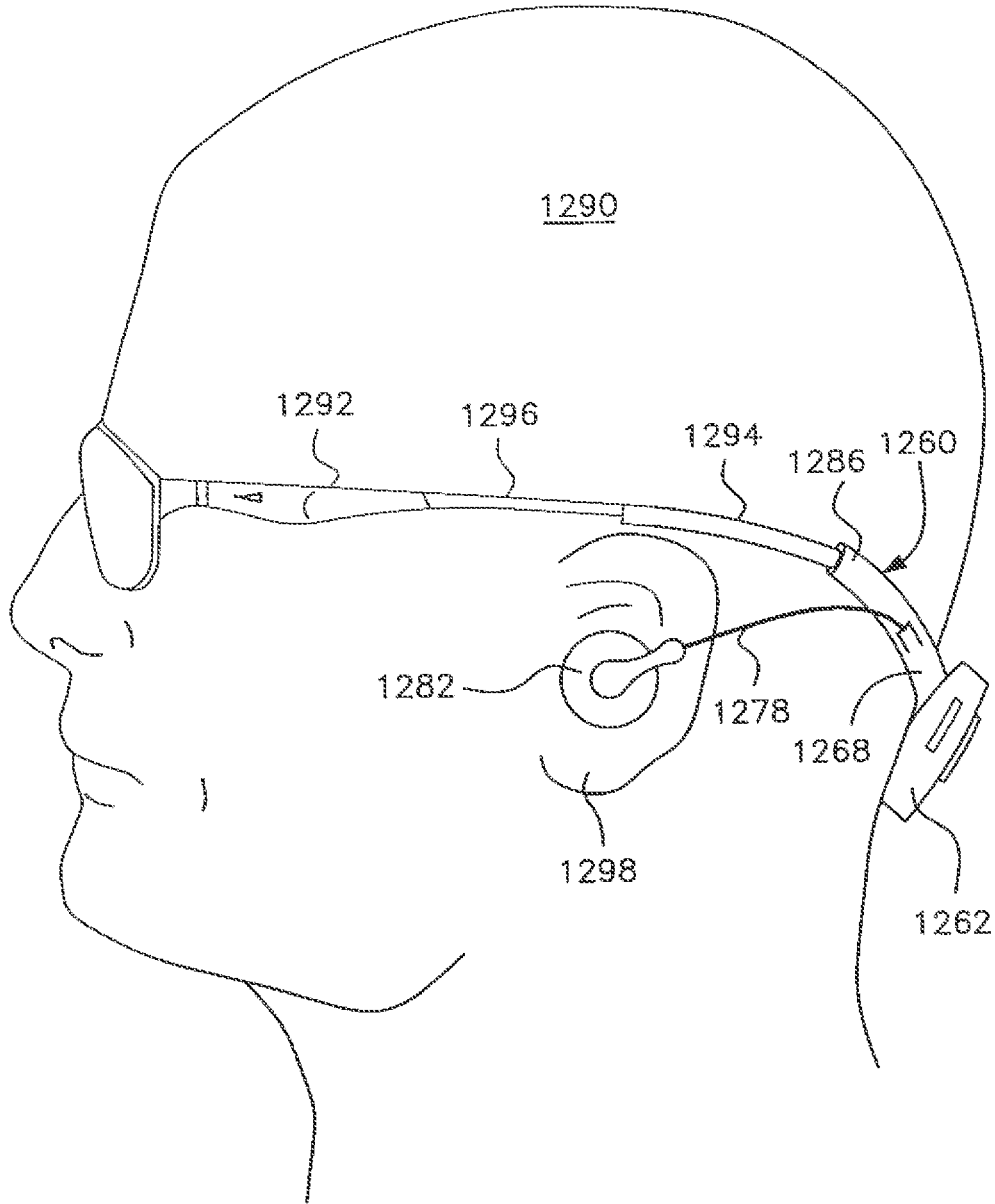

FIG. 34B

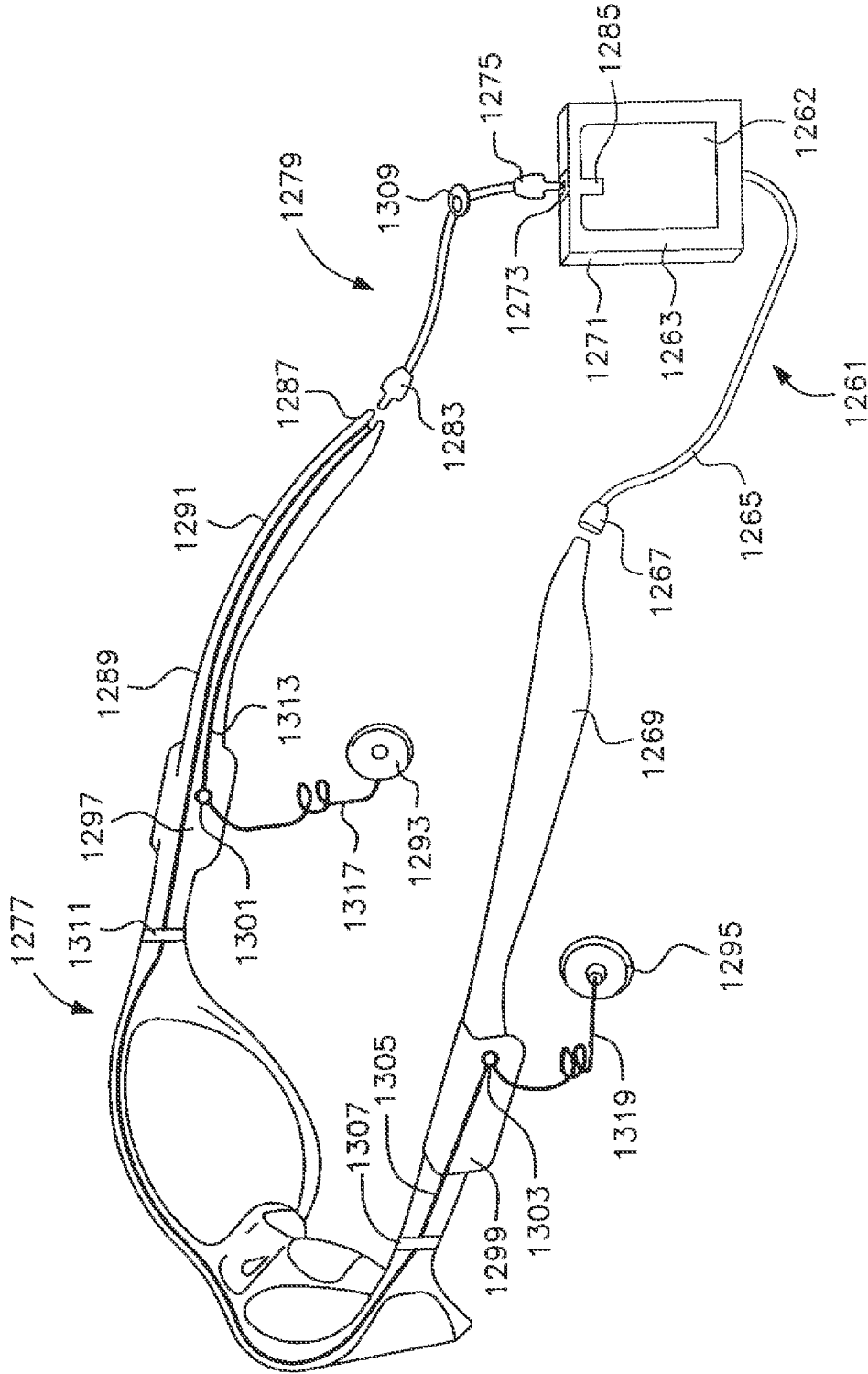

FIG. 34C
(PRIOR ART)

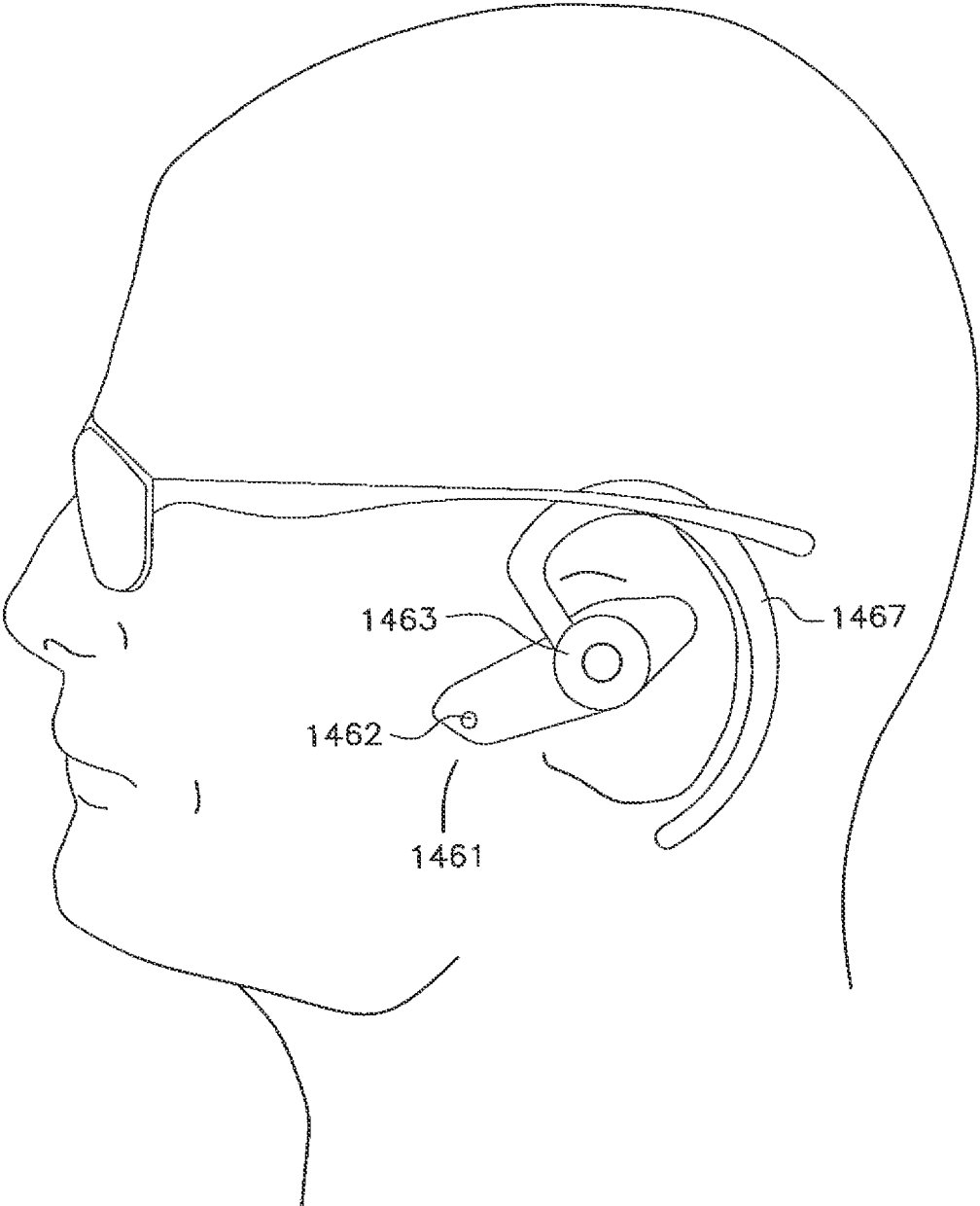

FIG. 34D

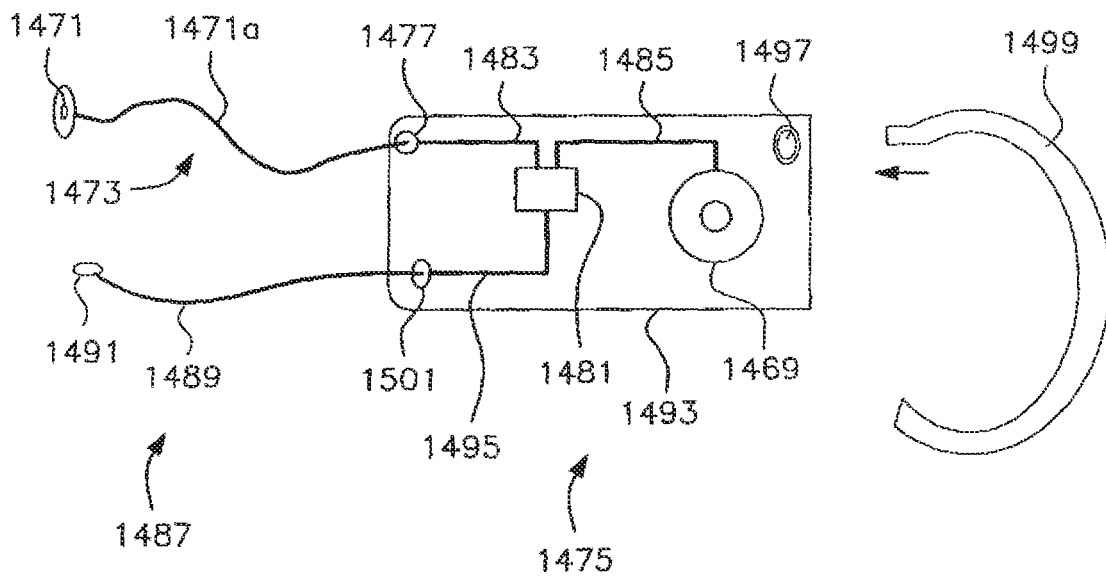

FIG. 34E

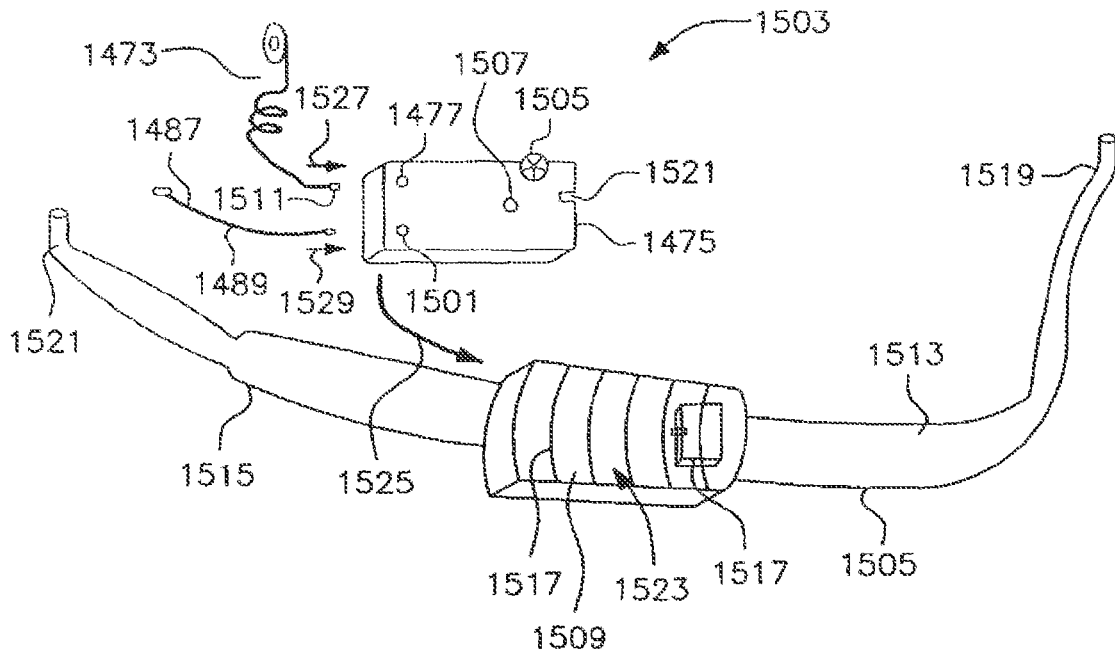

FIG. 34F

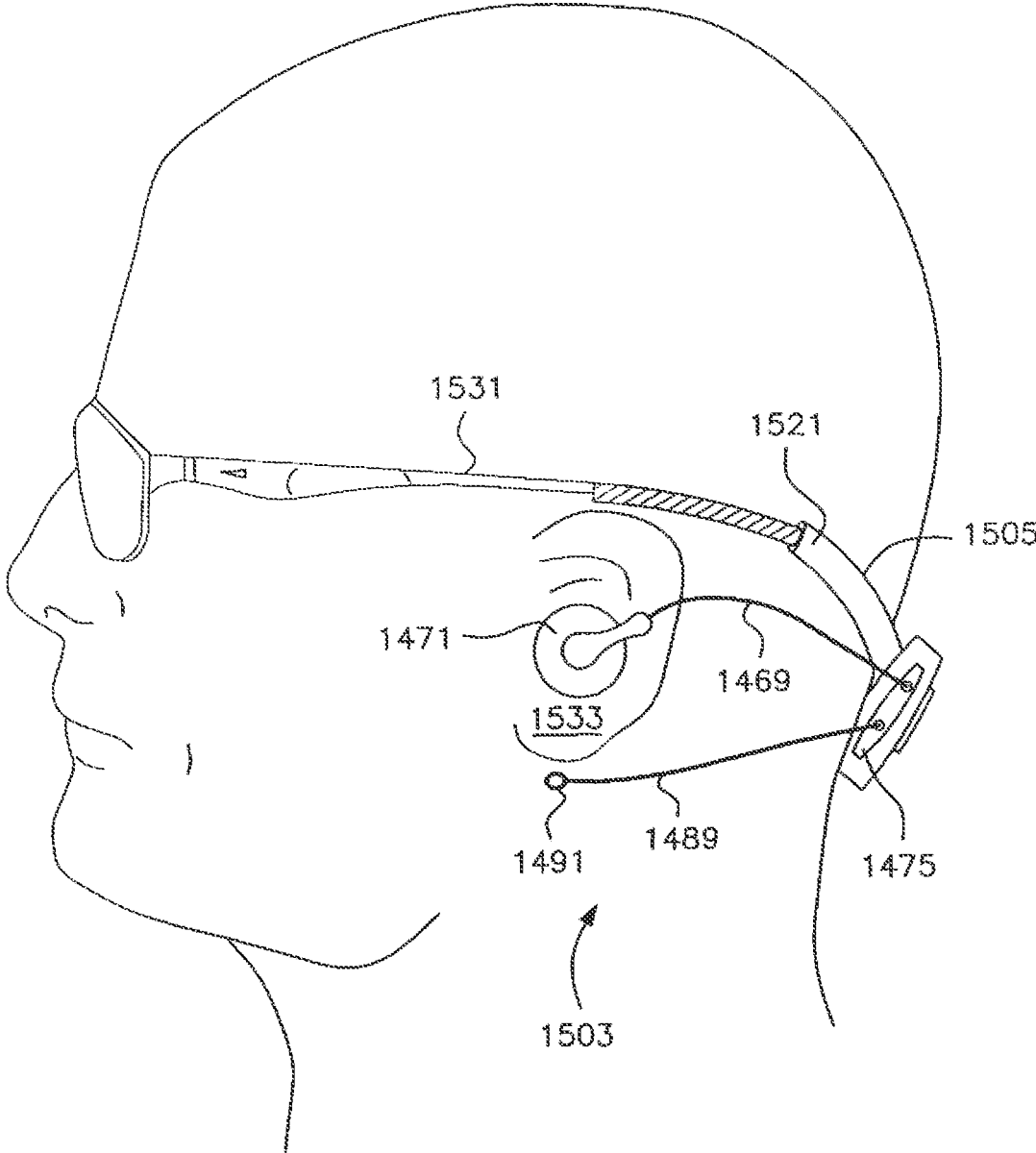

FIG. 34G

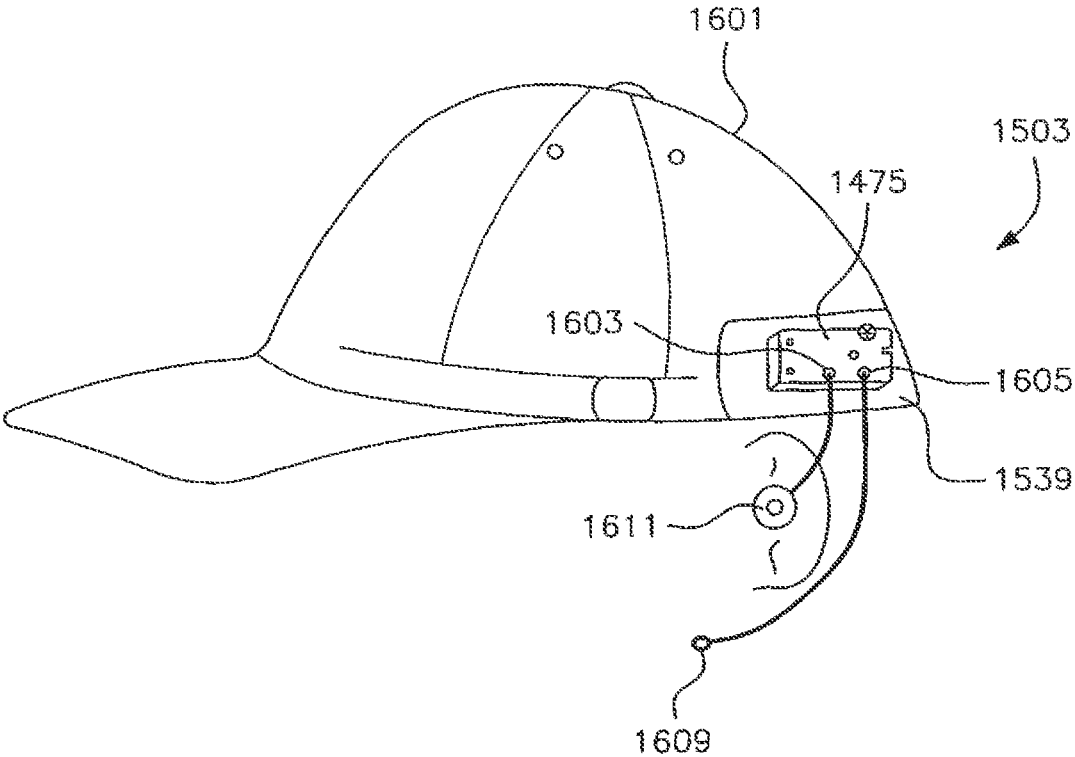

FIG. 34H

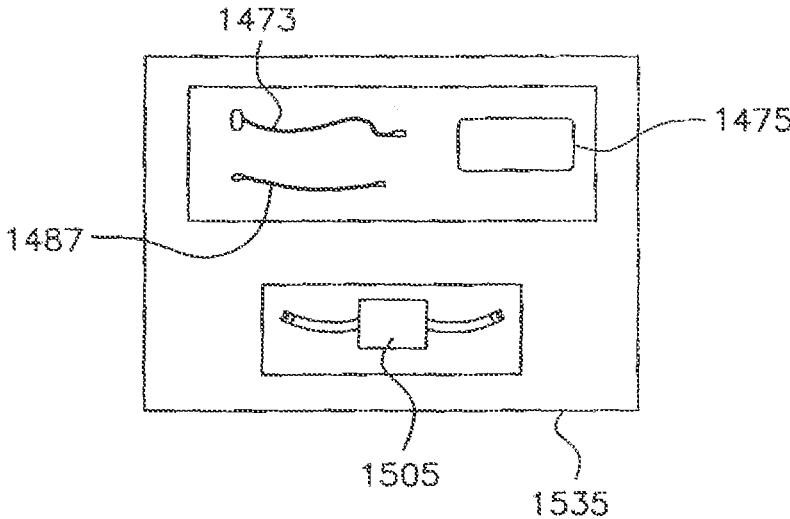

FIG. 34J

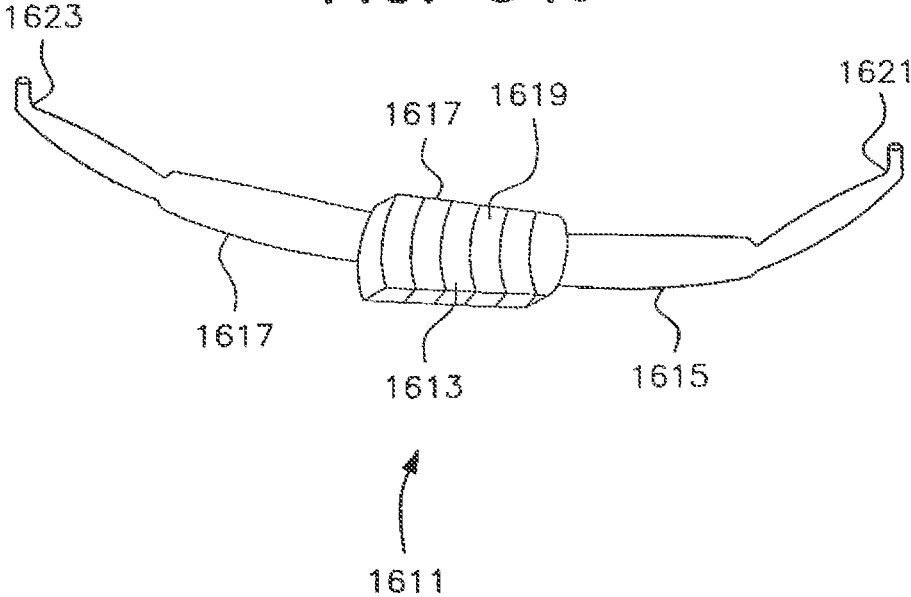

FIG. 34K

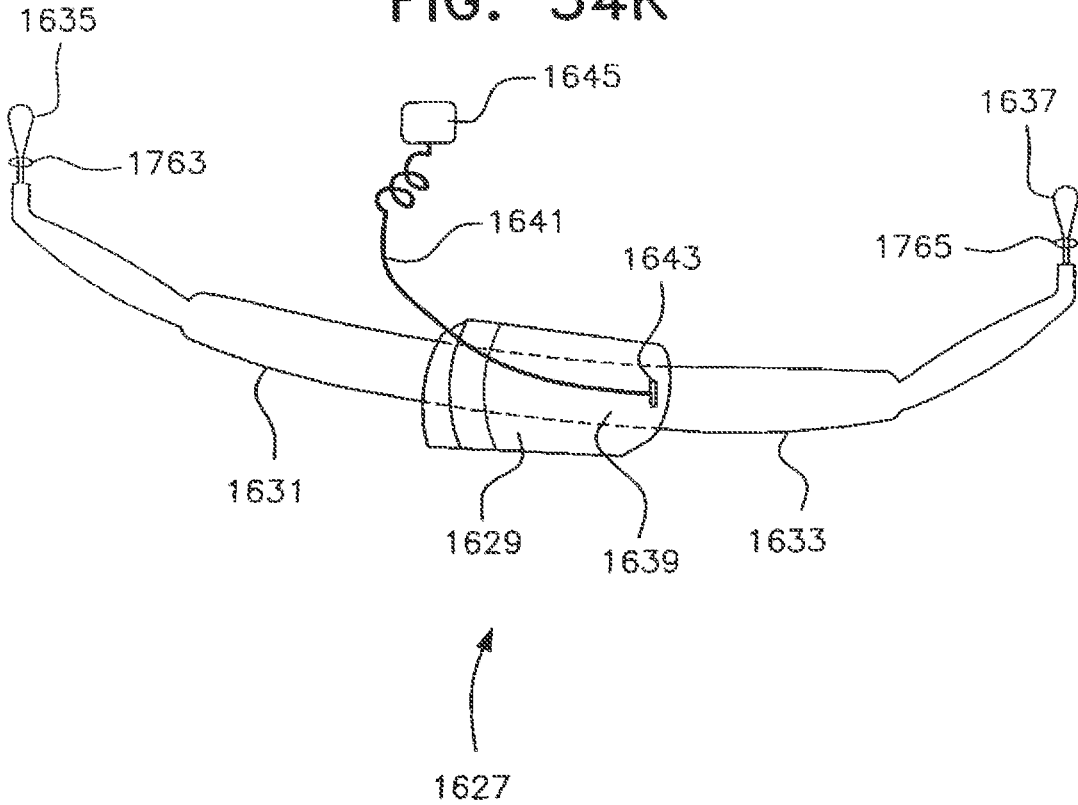

FIG. 34L

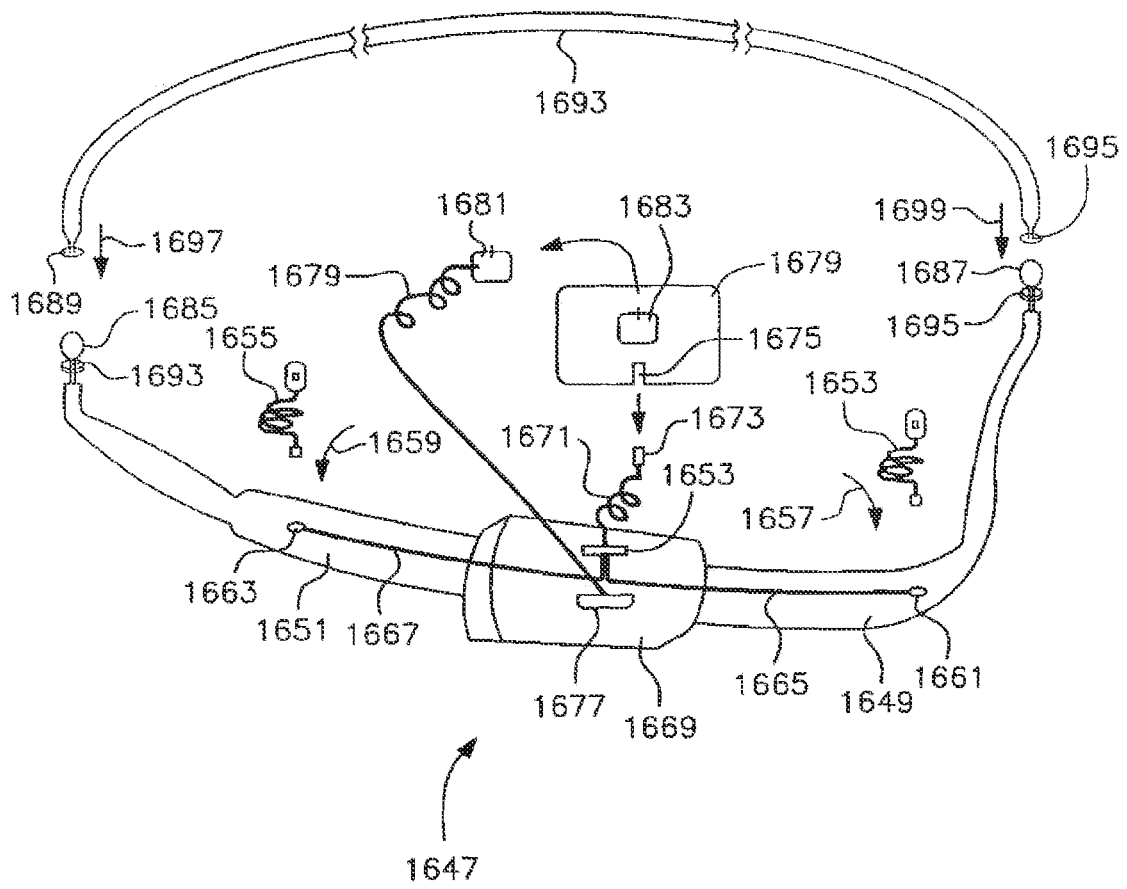

FIG. 34M

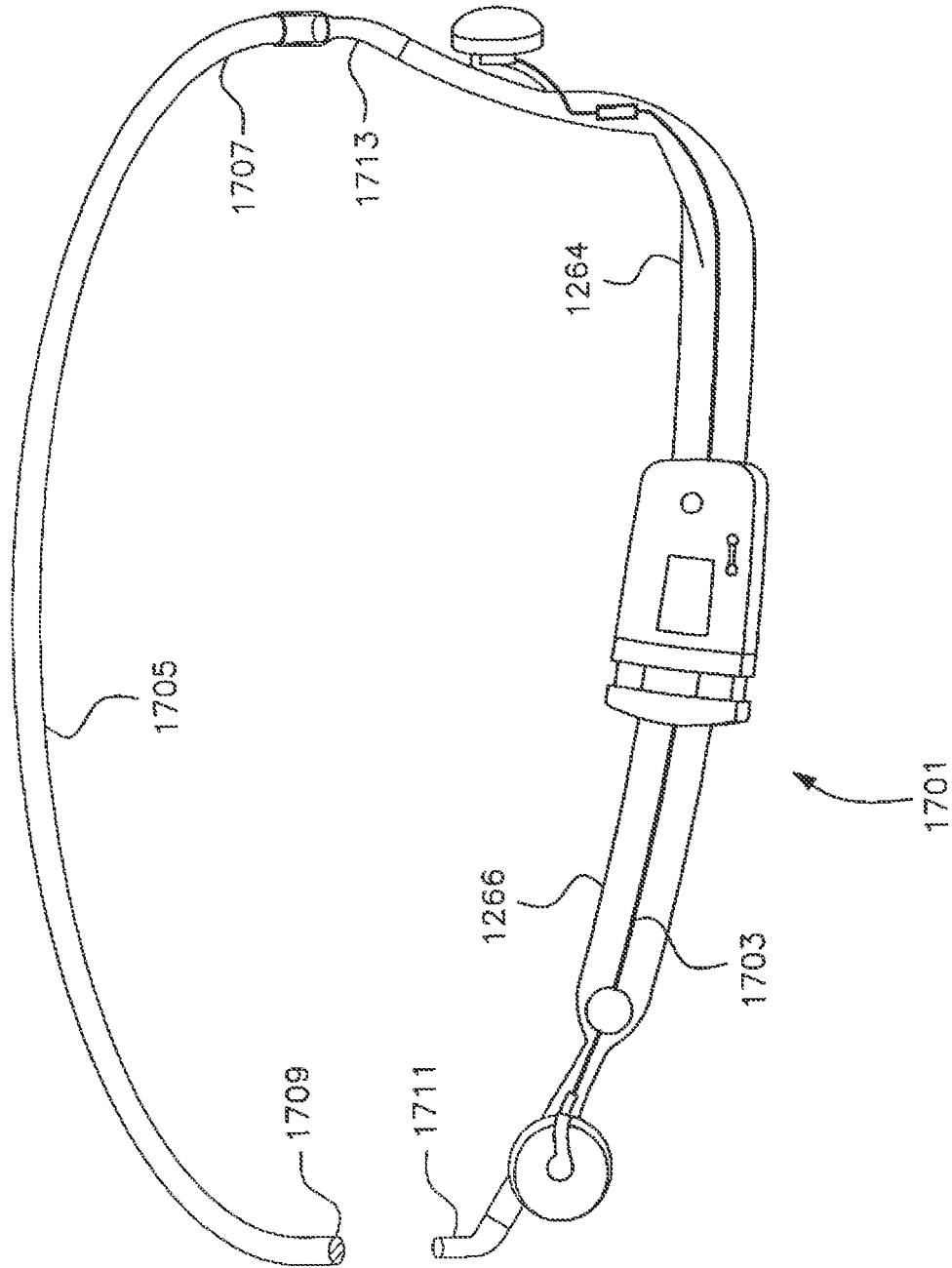

FIG. 340

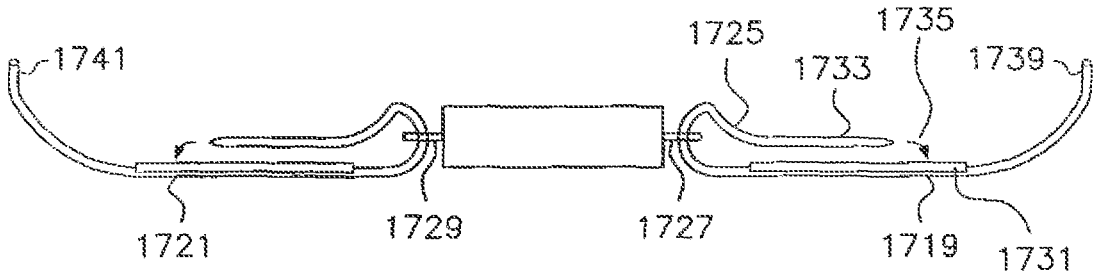

FIG. 34N

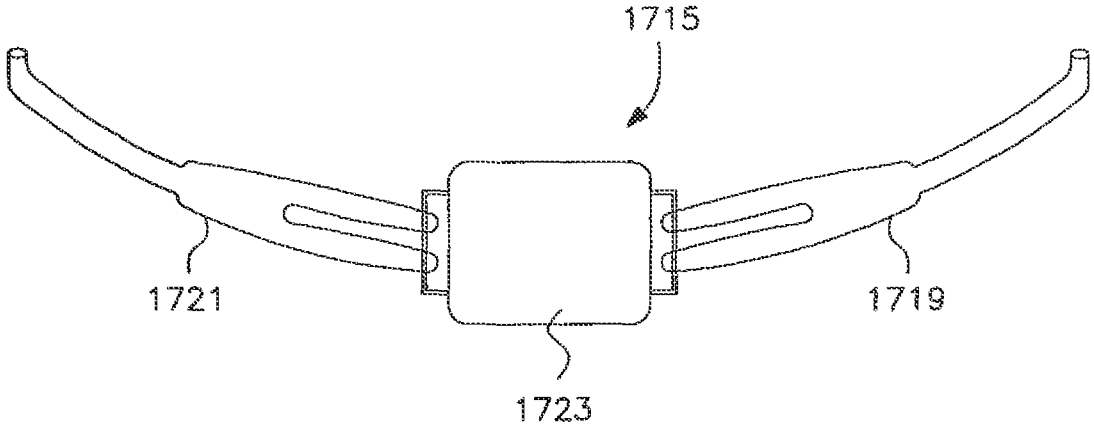

FIG. 34P

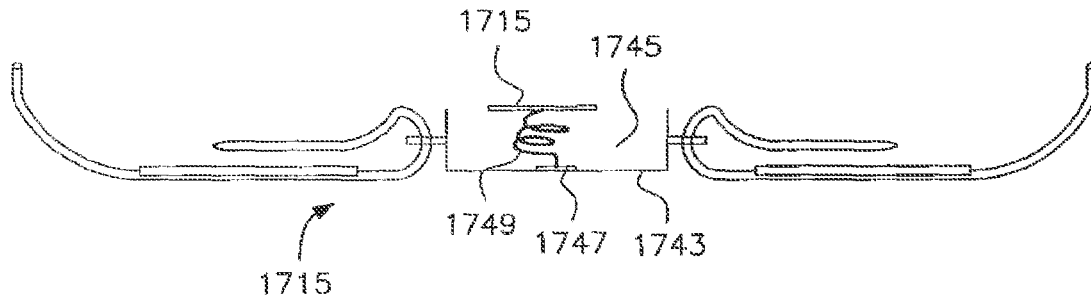

FIG. 34Q

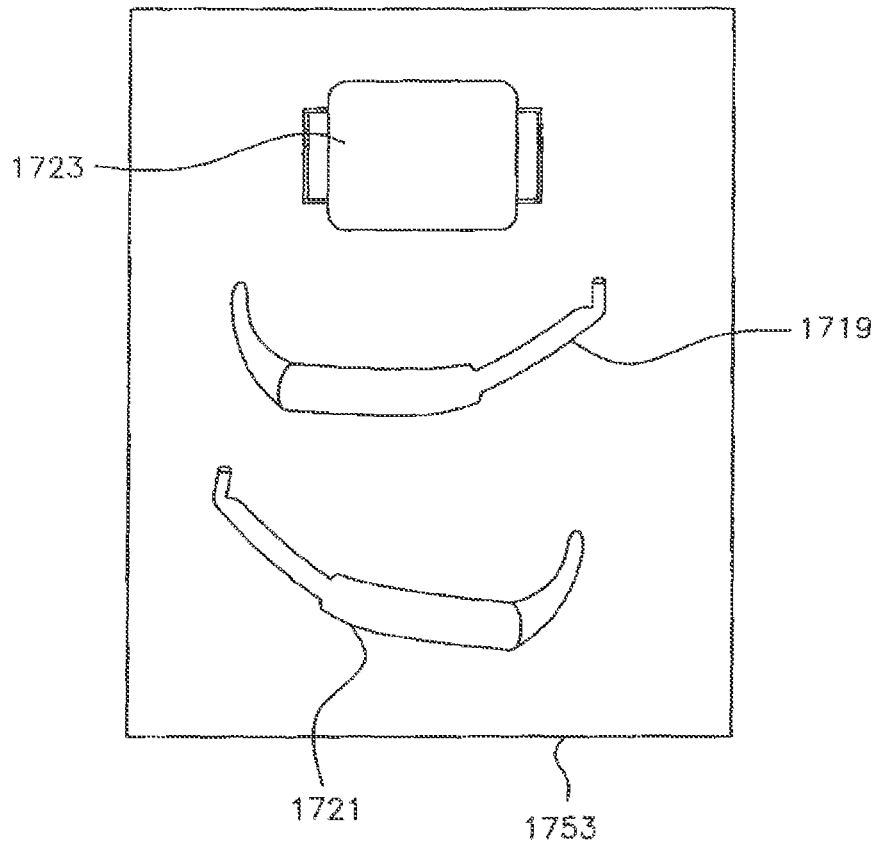

FIG. 34R

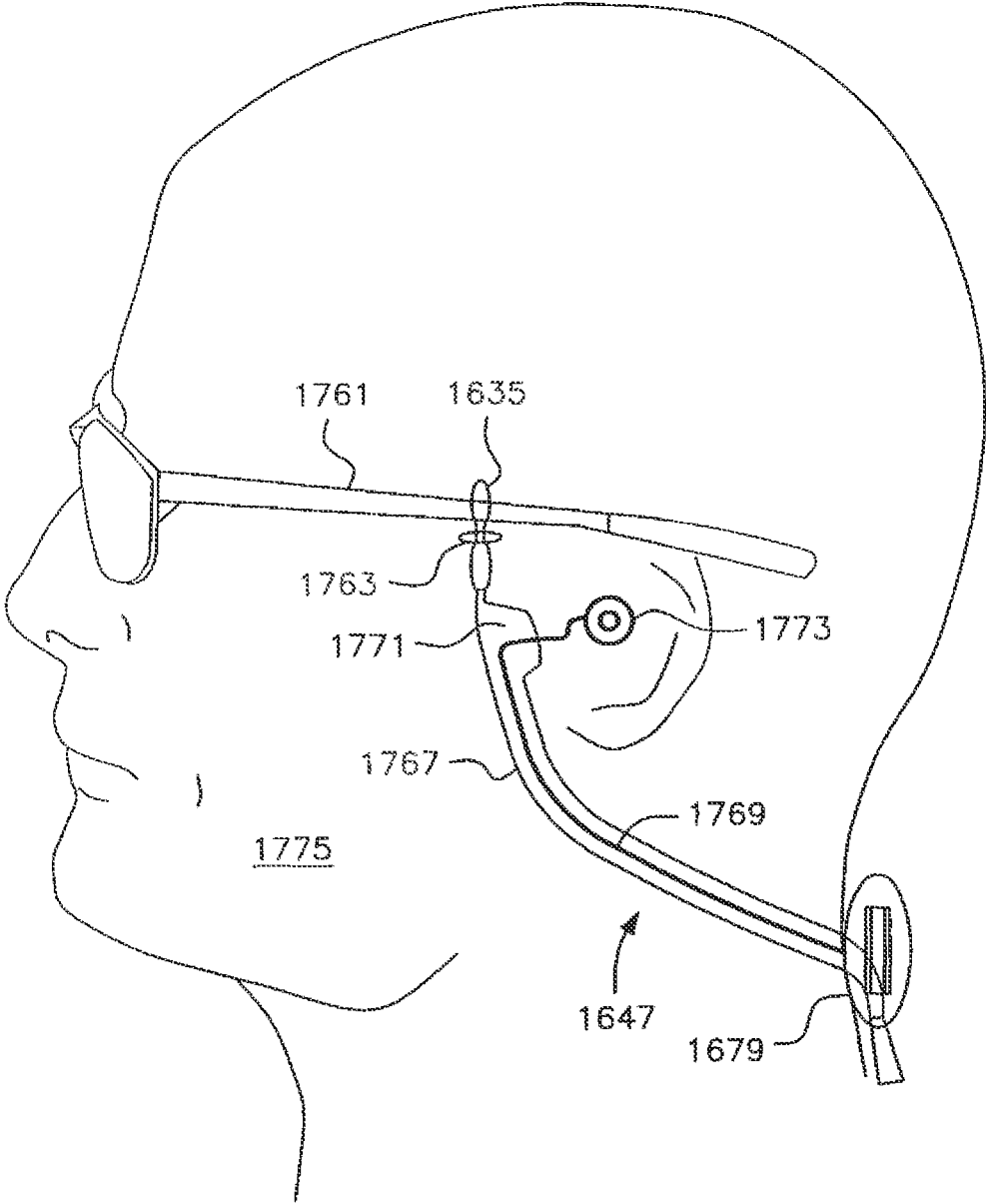

FIG. 34V

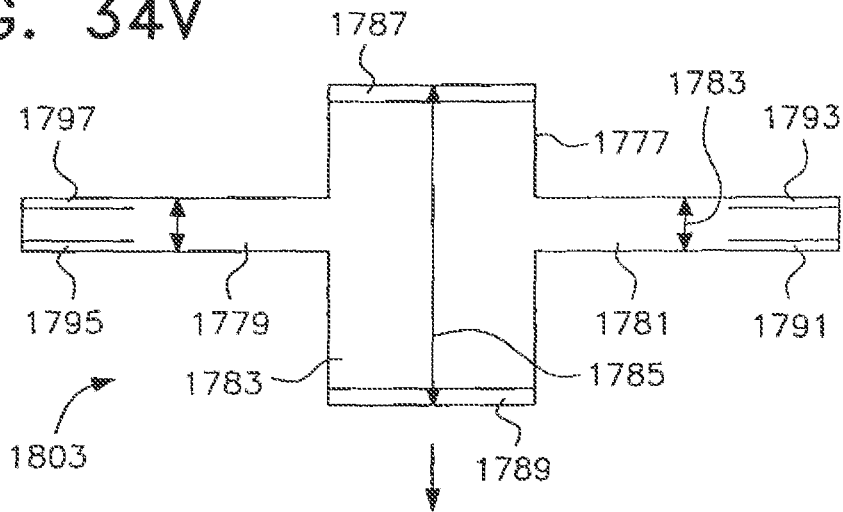

FIG. 34U

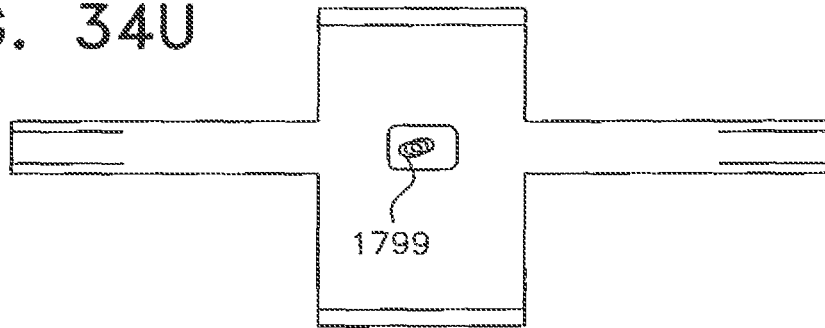

FIG. 34S

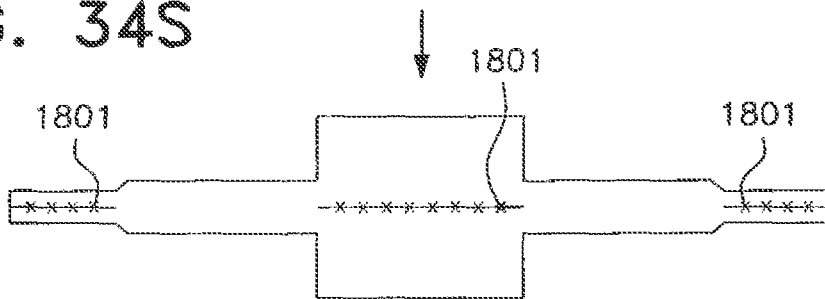

FIG. 34T

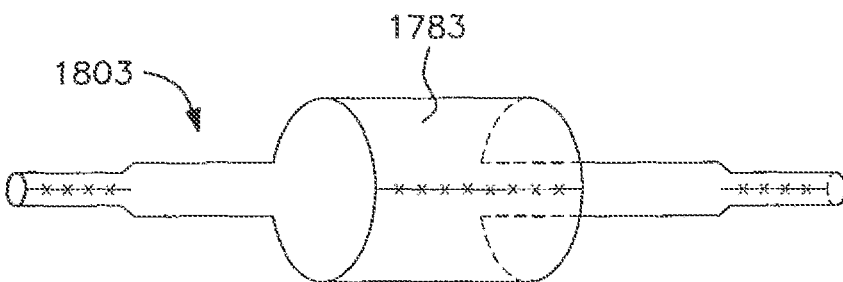

FIG. 35

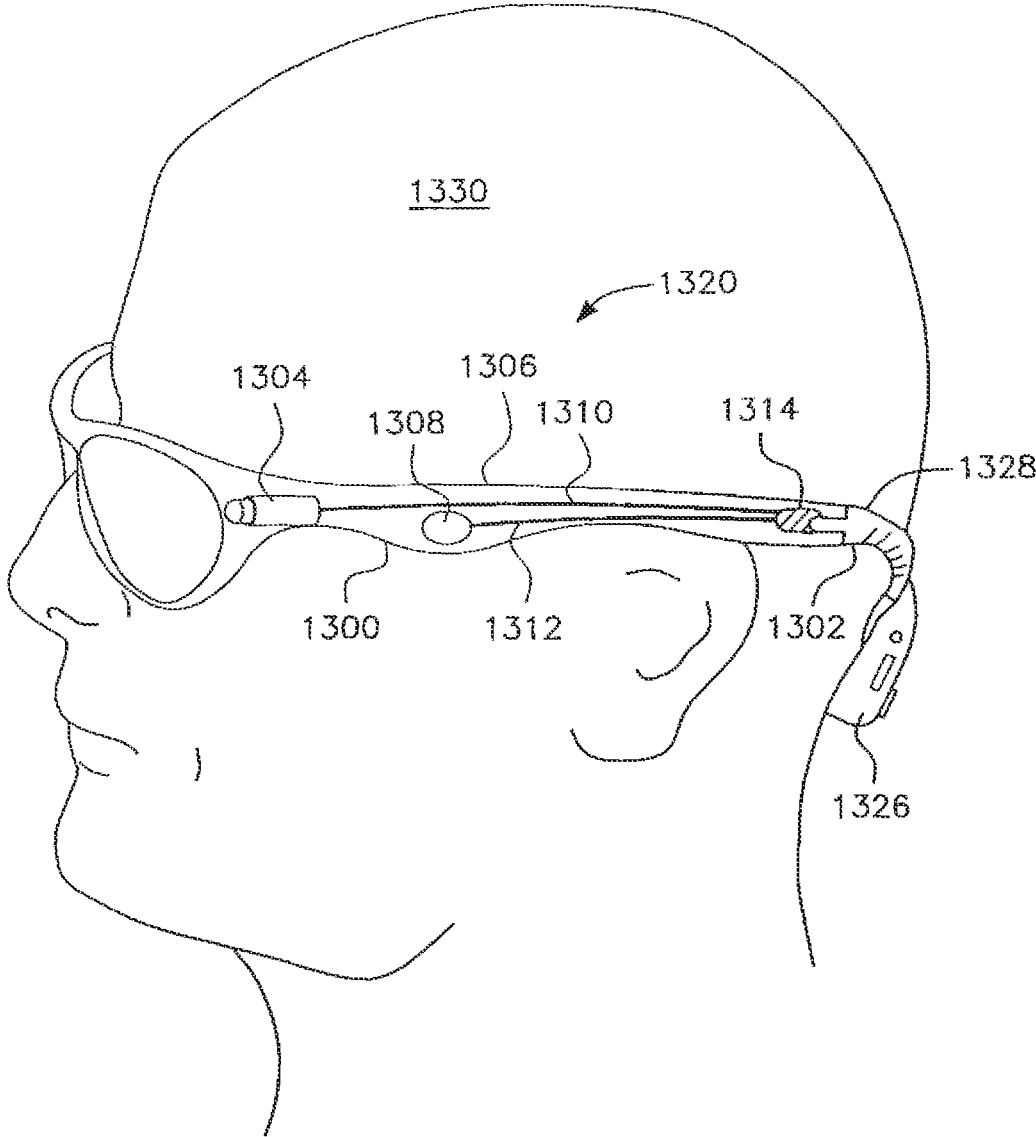

FIG. 36

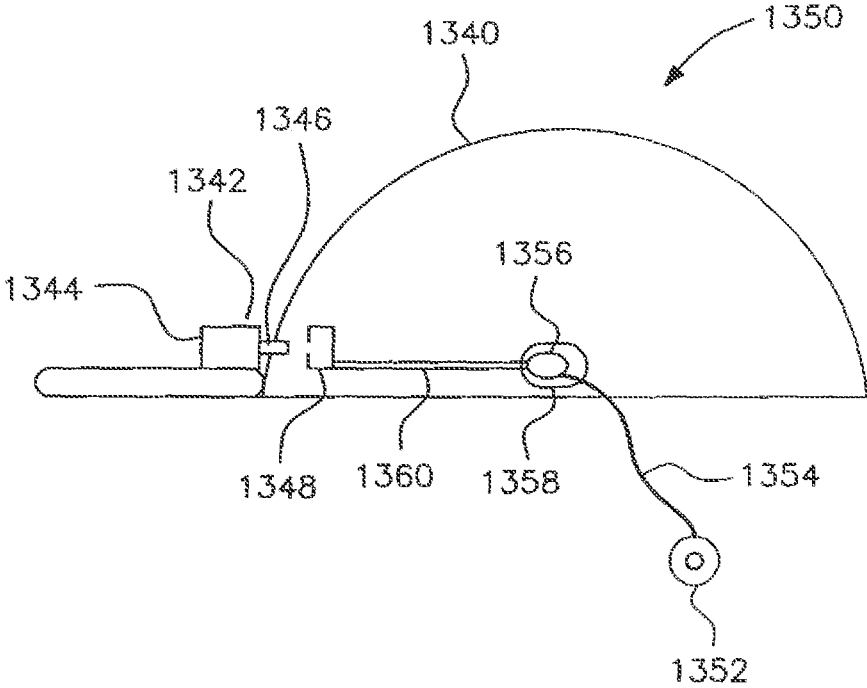

FIG. 37

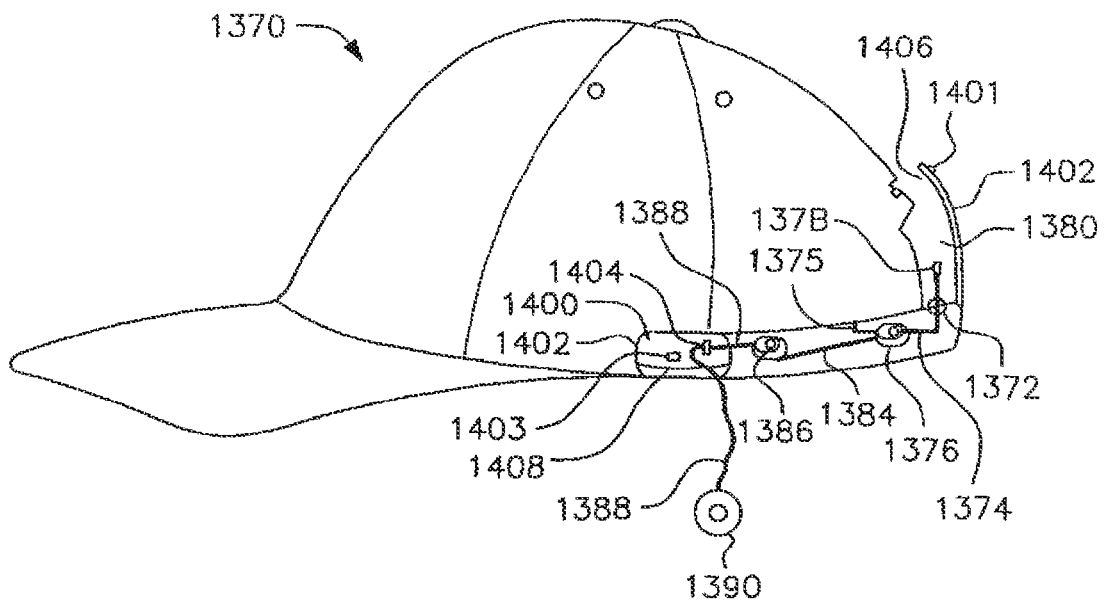

FIG. 37A

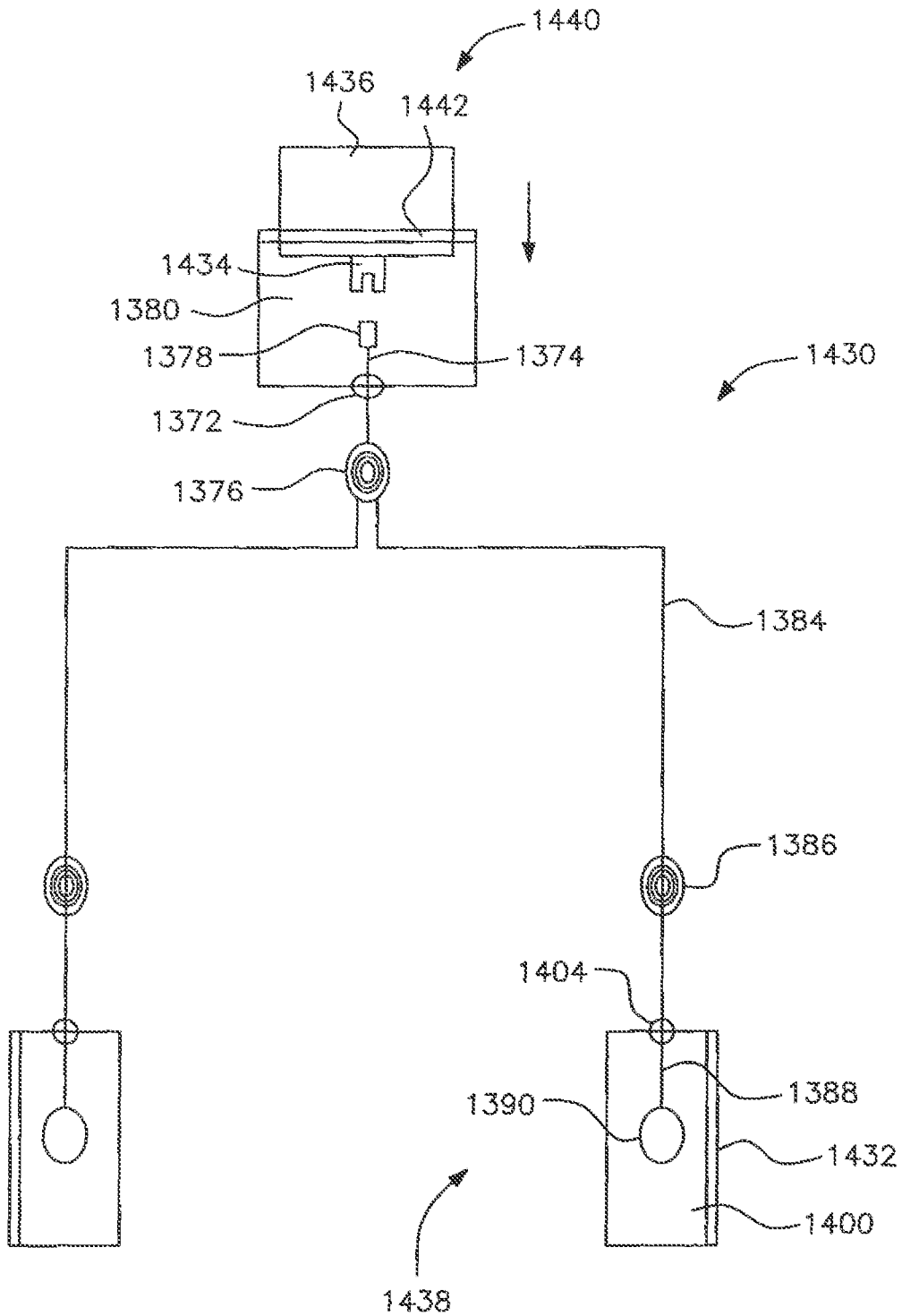

FIG. 37B

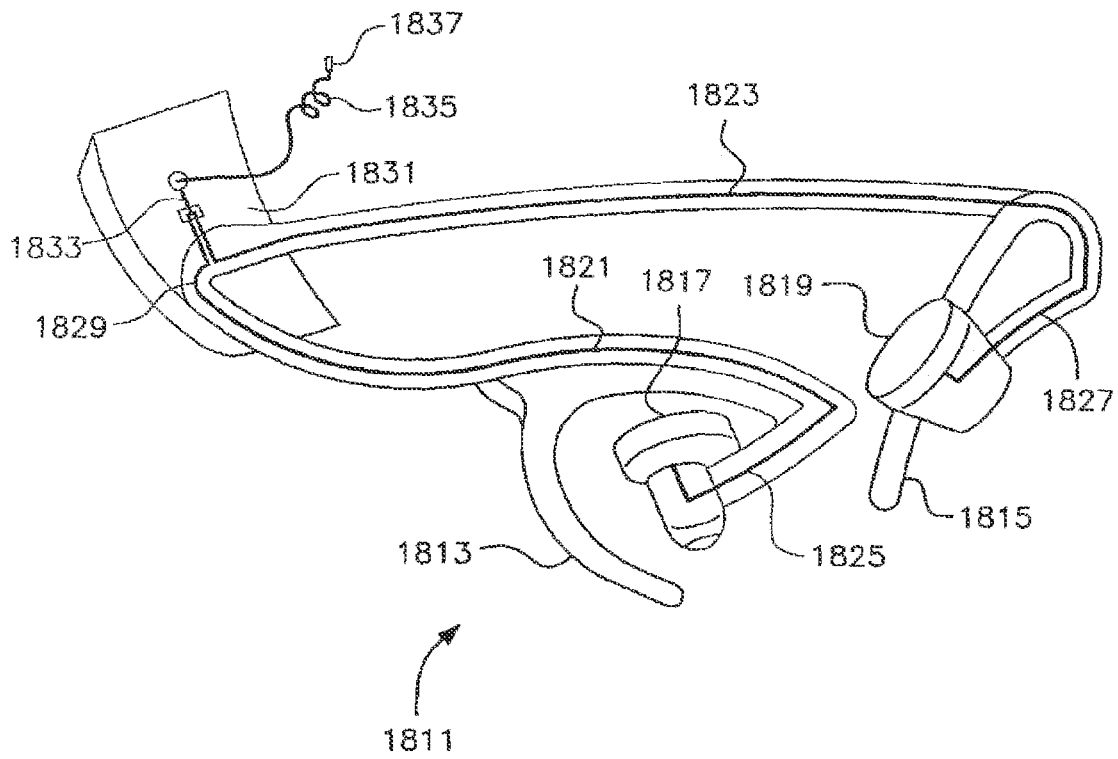

FIG. 37C

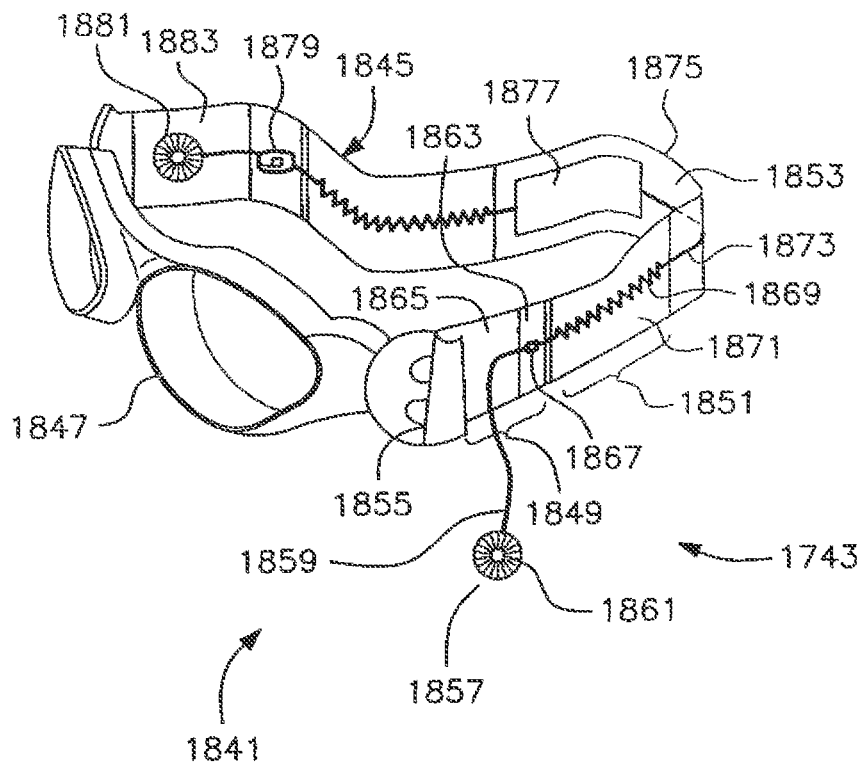

FIG. 38

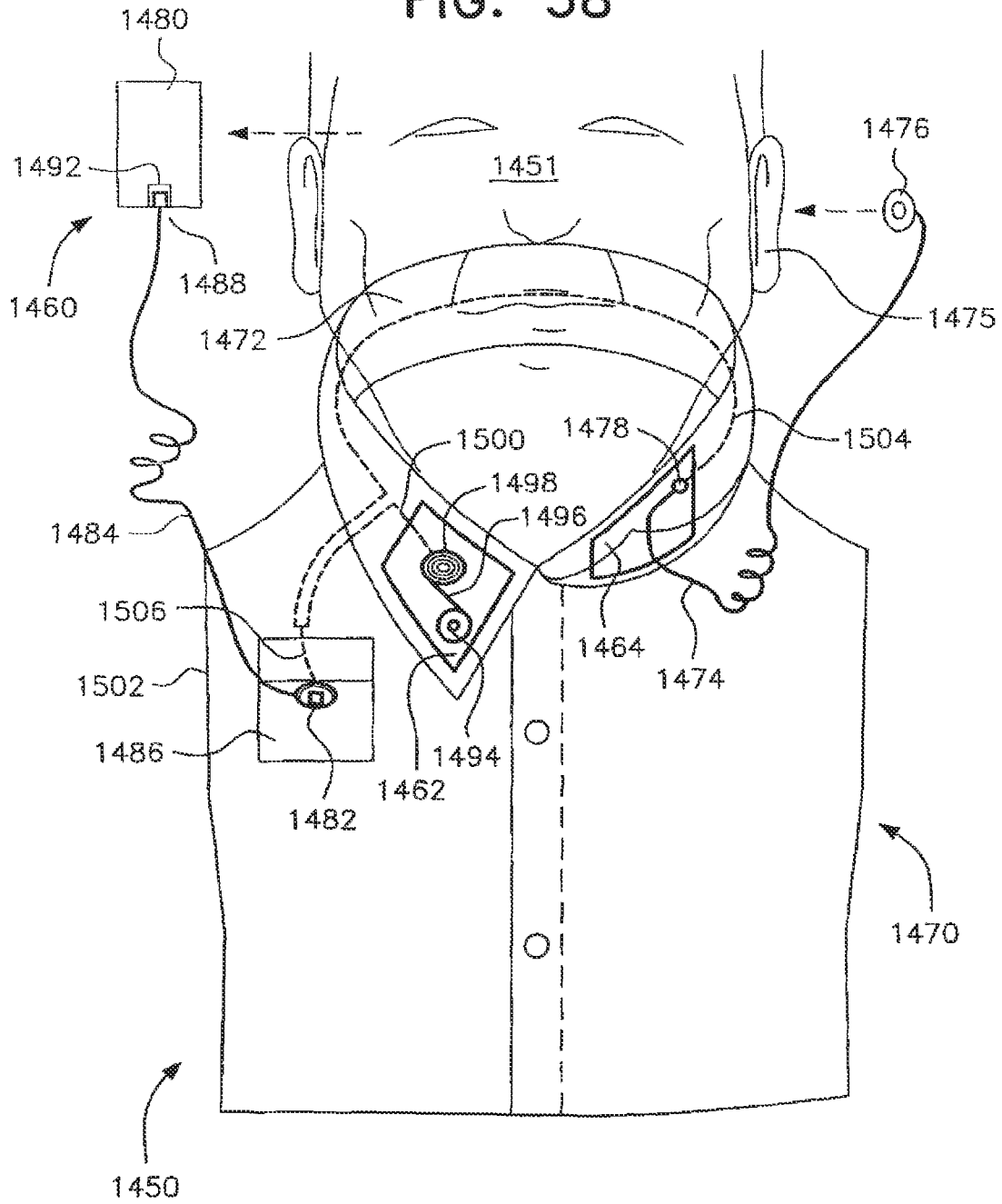

FIG. 39

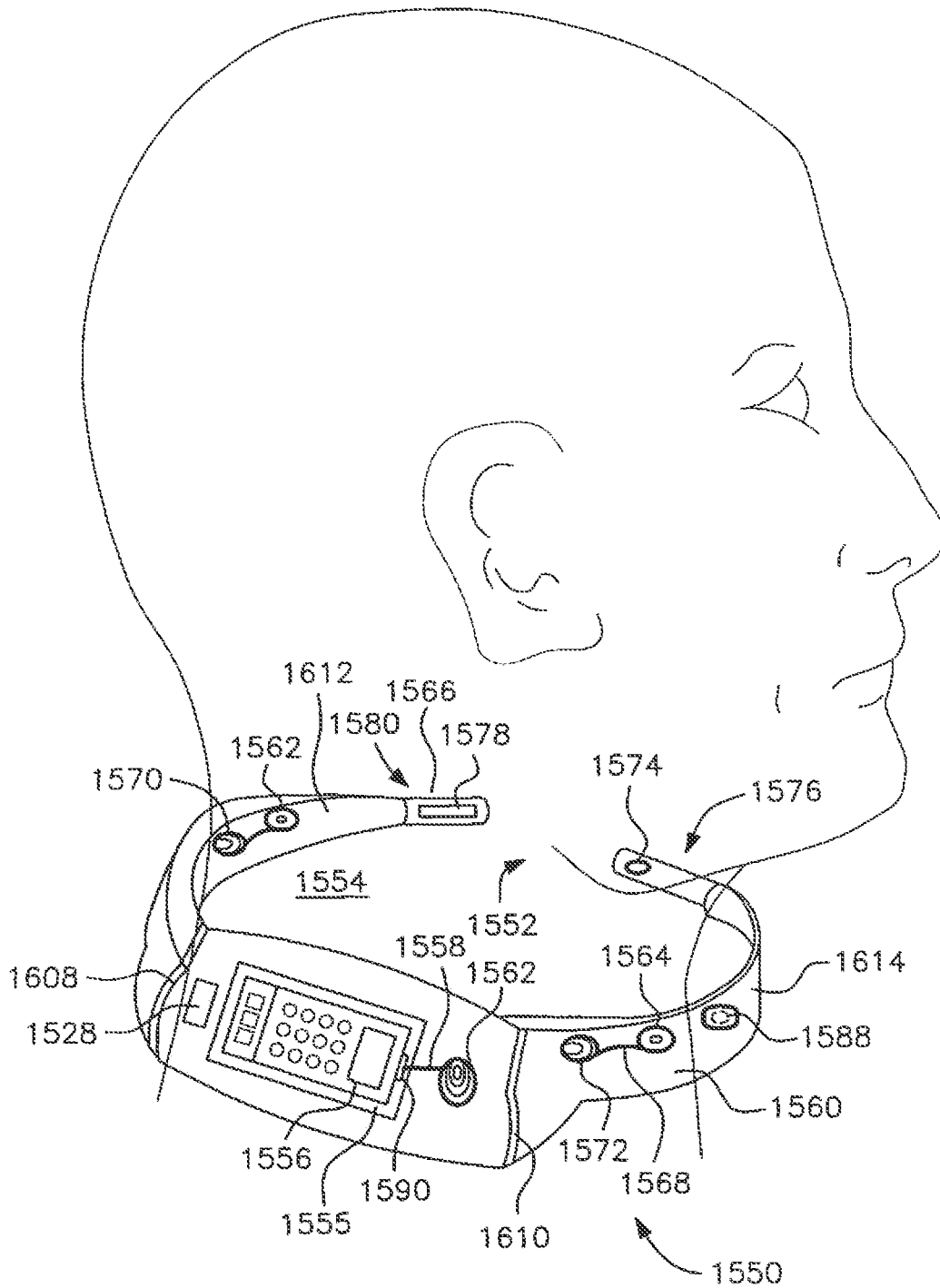

FIG. 39A

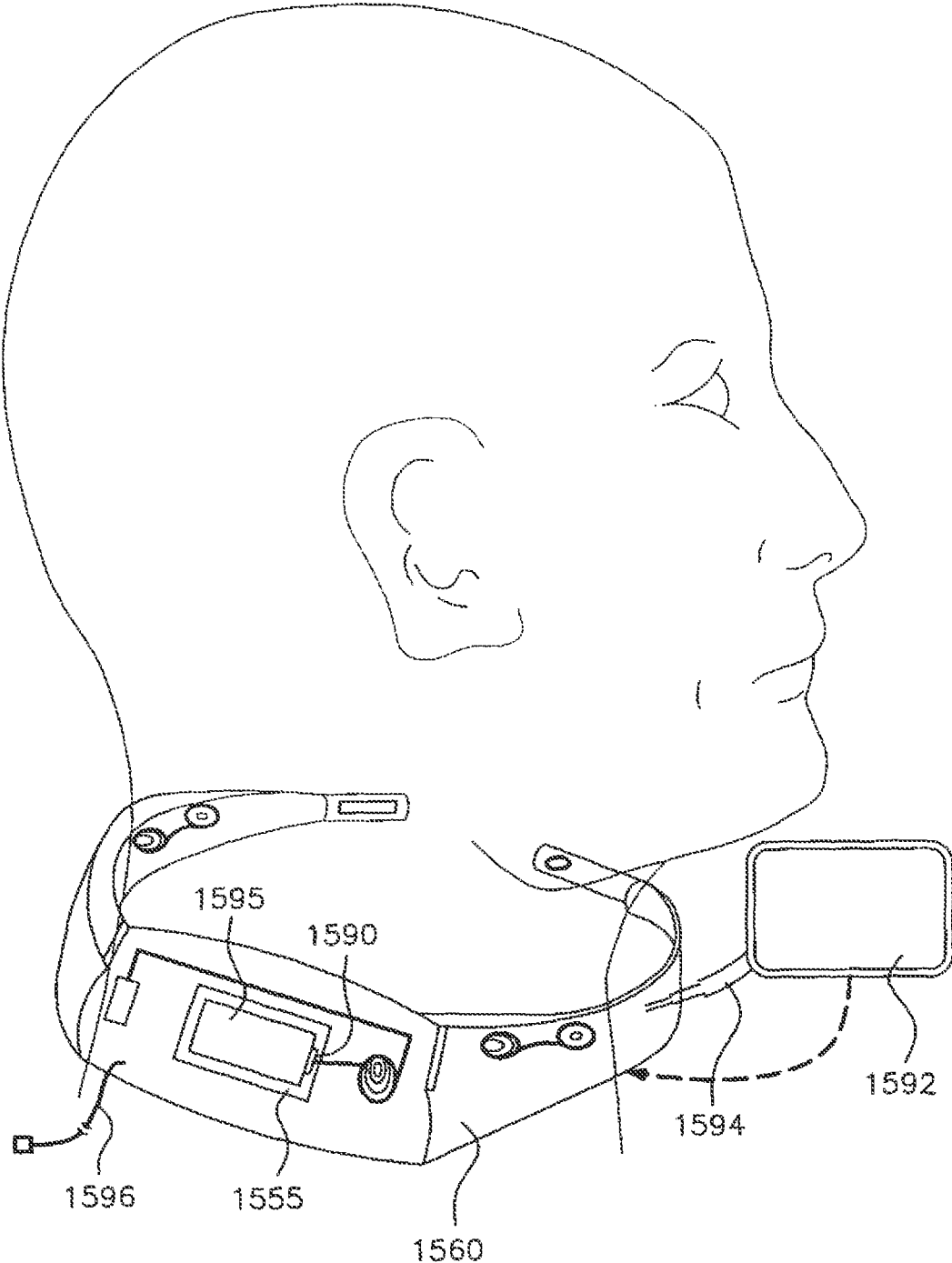

FIG. 39B

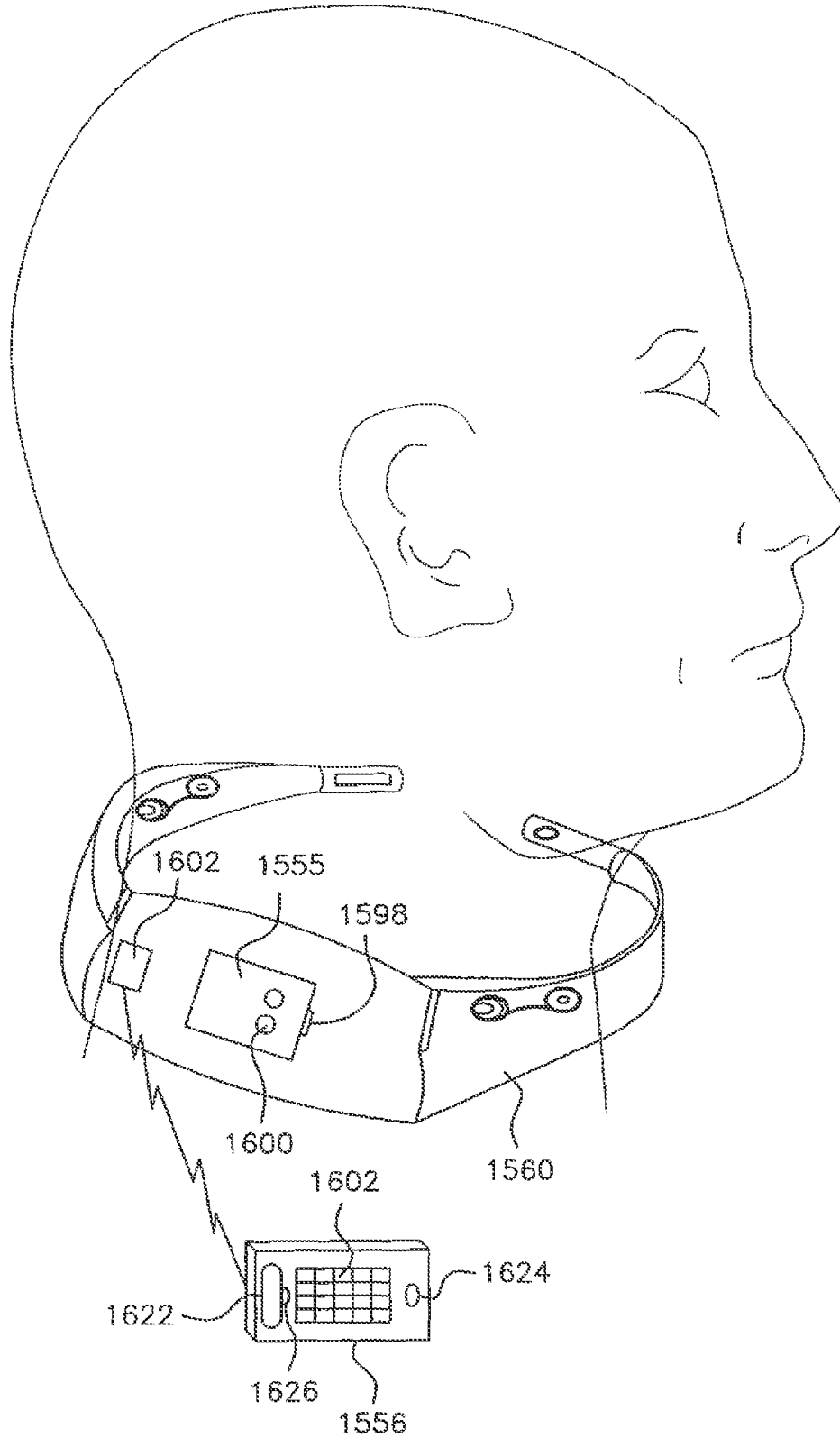

FIG. 40

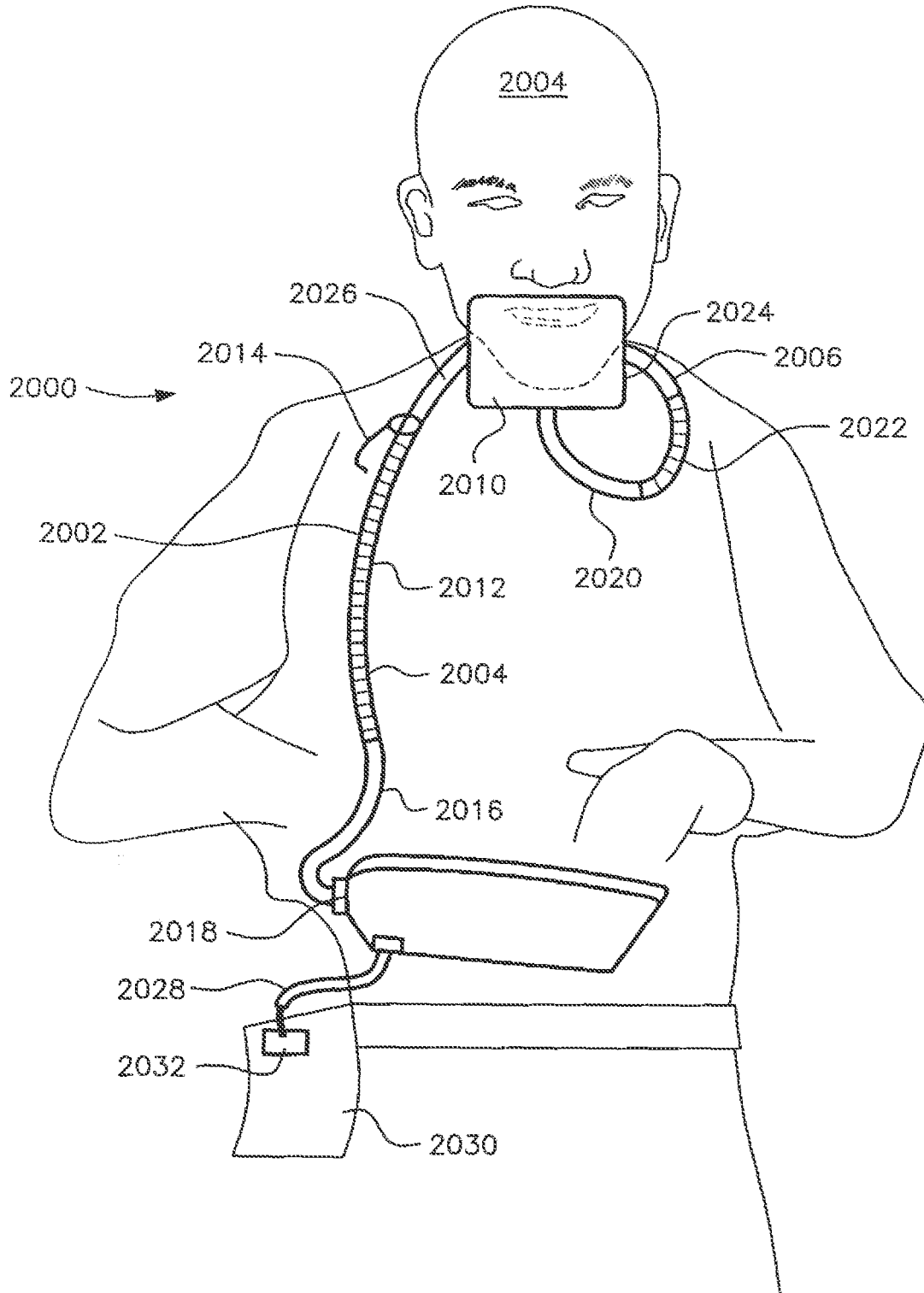

FIG. 41

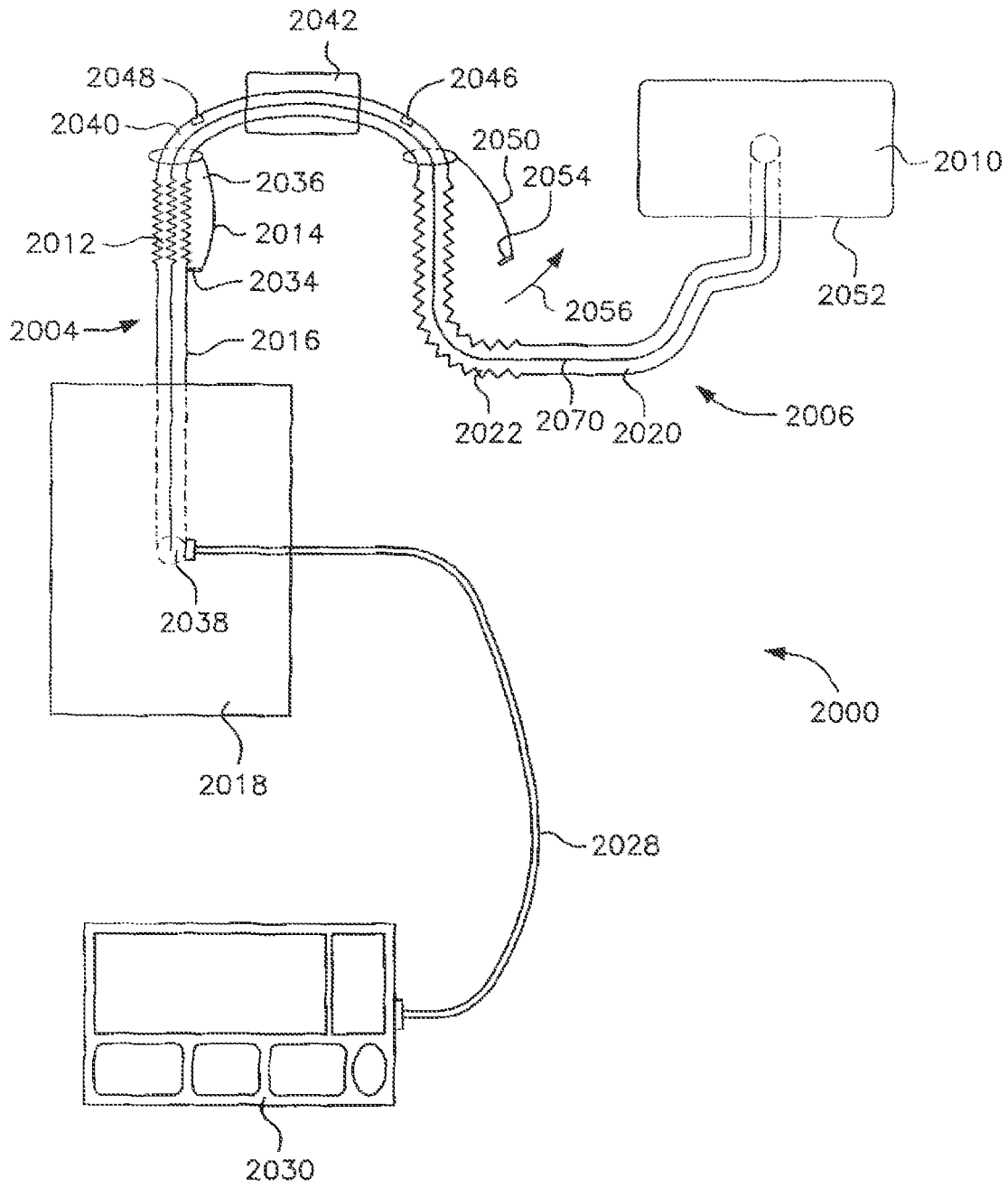

FIG. 42A

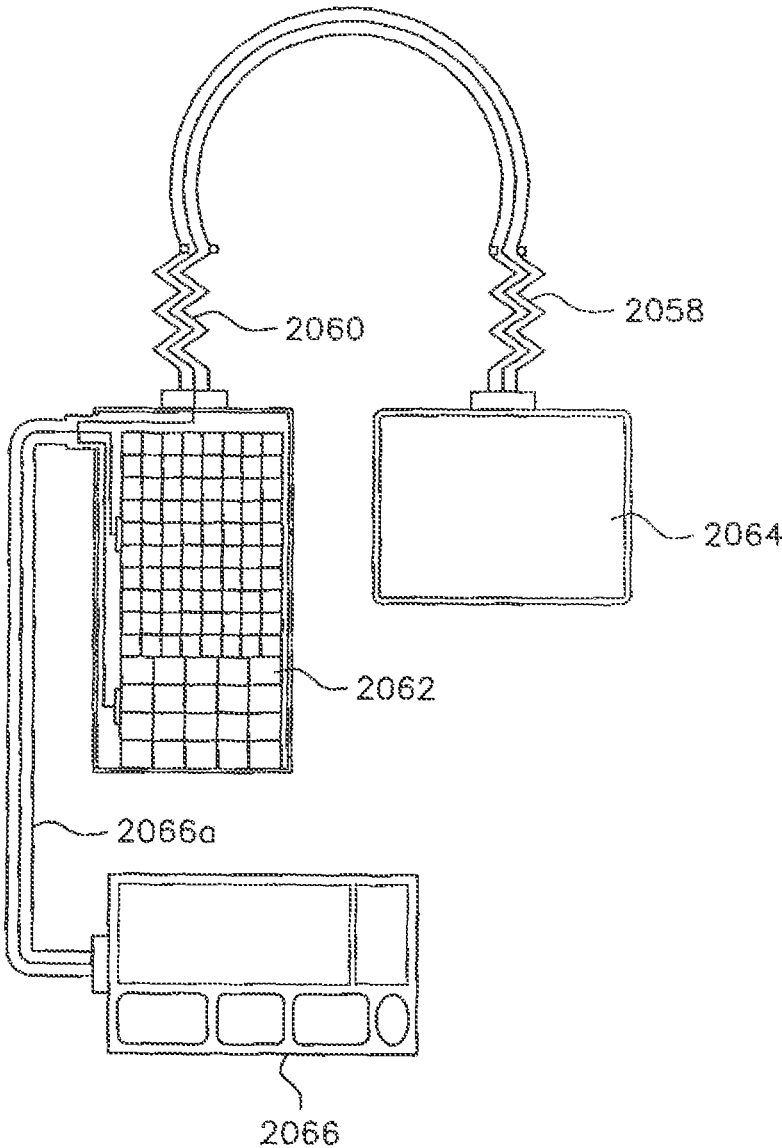

FIG. 42B

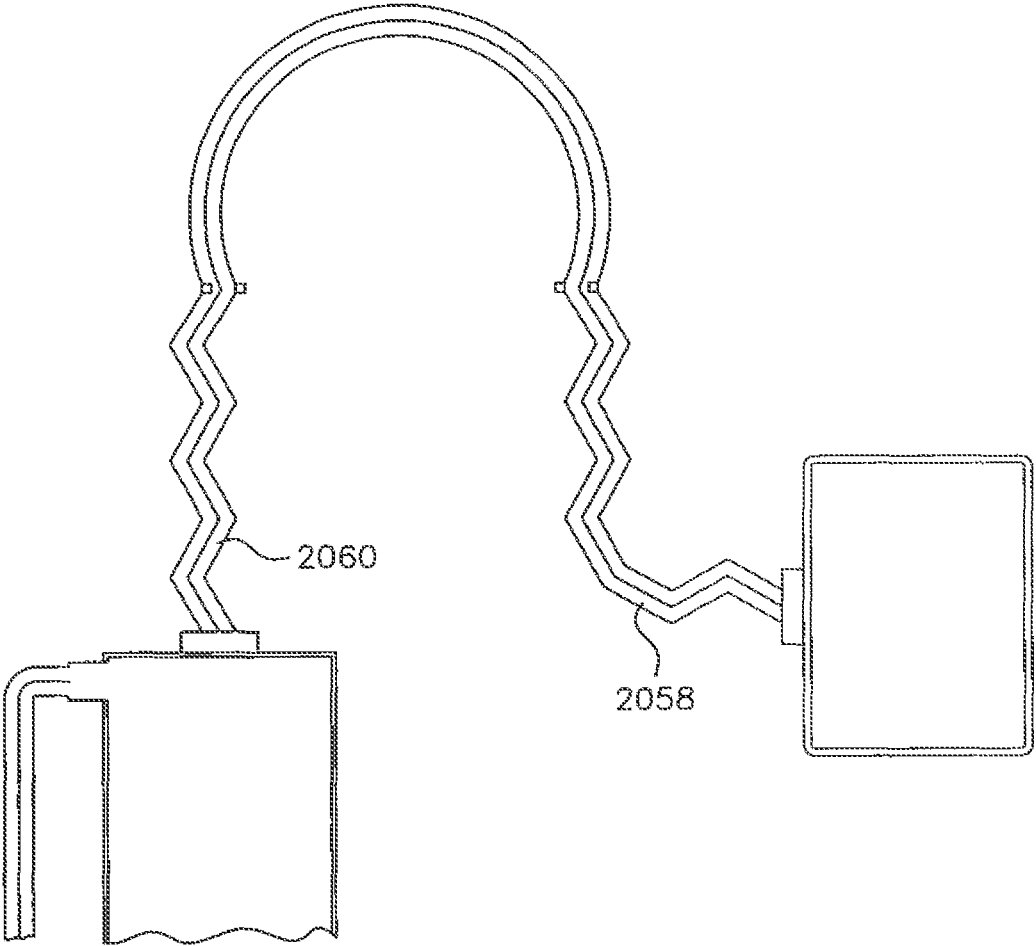

FIG. 43A

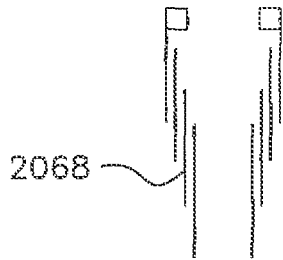

FIG. 43B

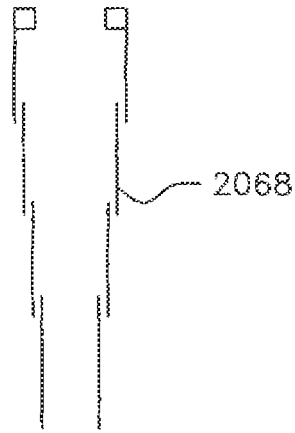

FIG. 43C

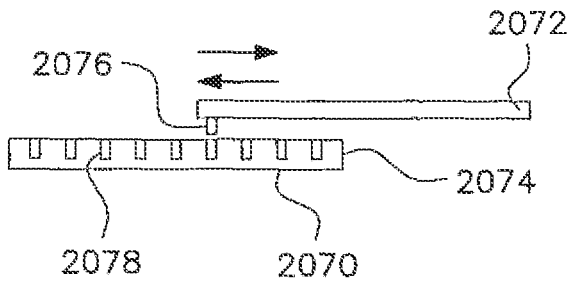

FIG. 43D

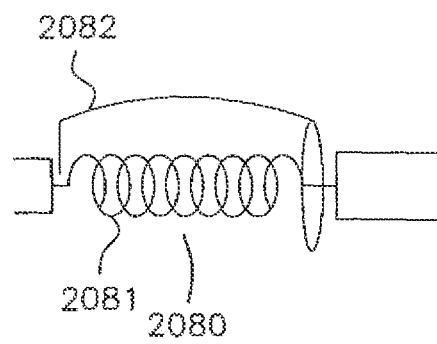

FIG. 43E

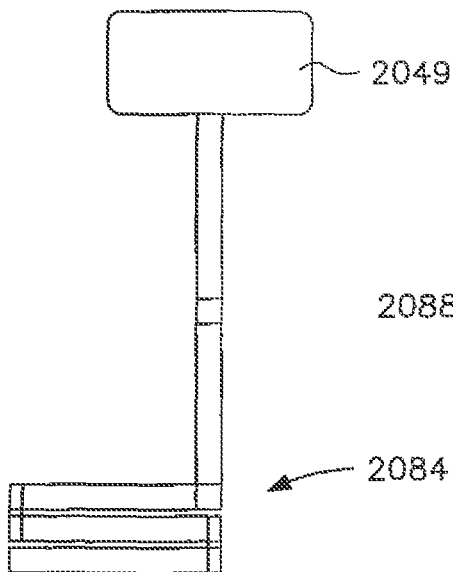

FIG. 43F

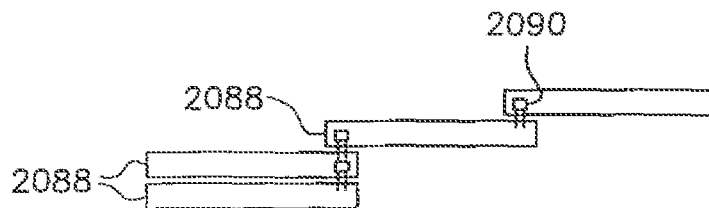

FIG. 43G

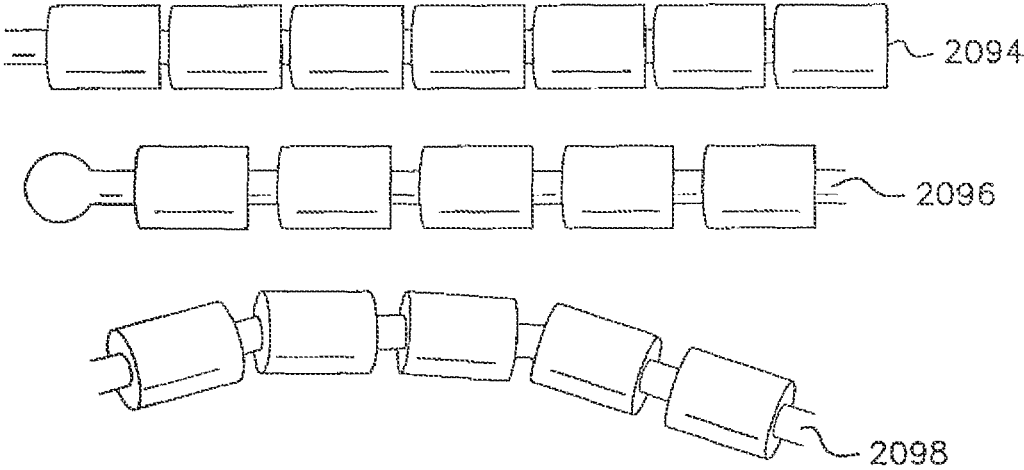

FIG. 43H

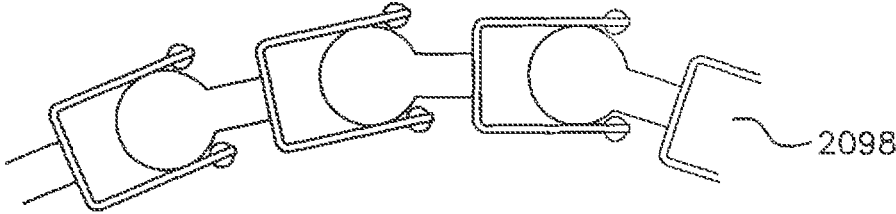

FIG. 44A FIG. 44B FIG. 44C FIG. 44D

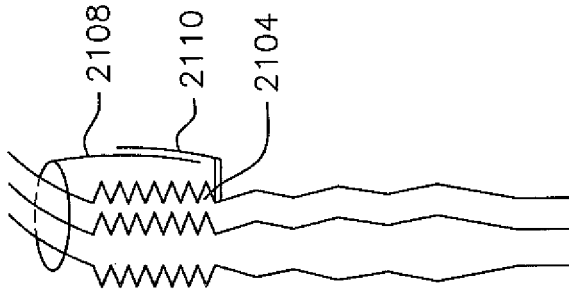
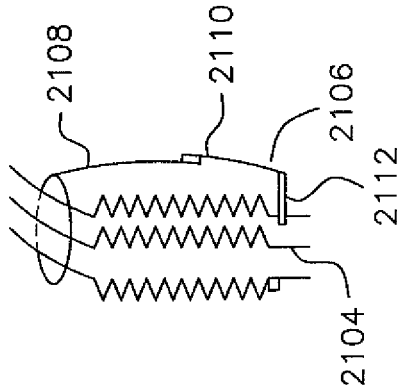
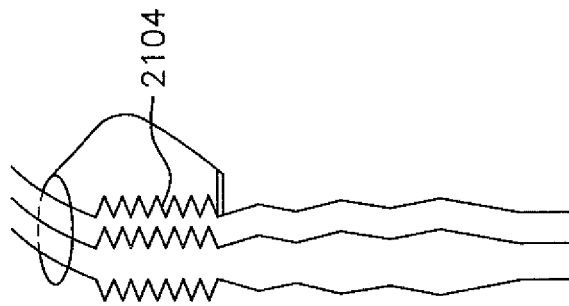
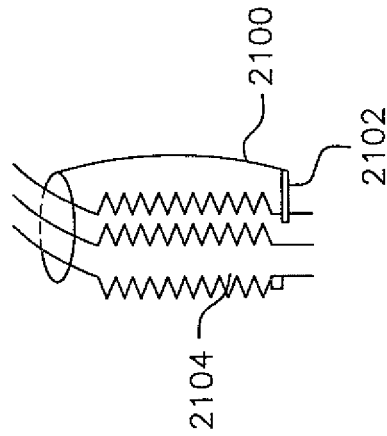

FIG. 45A

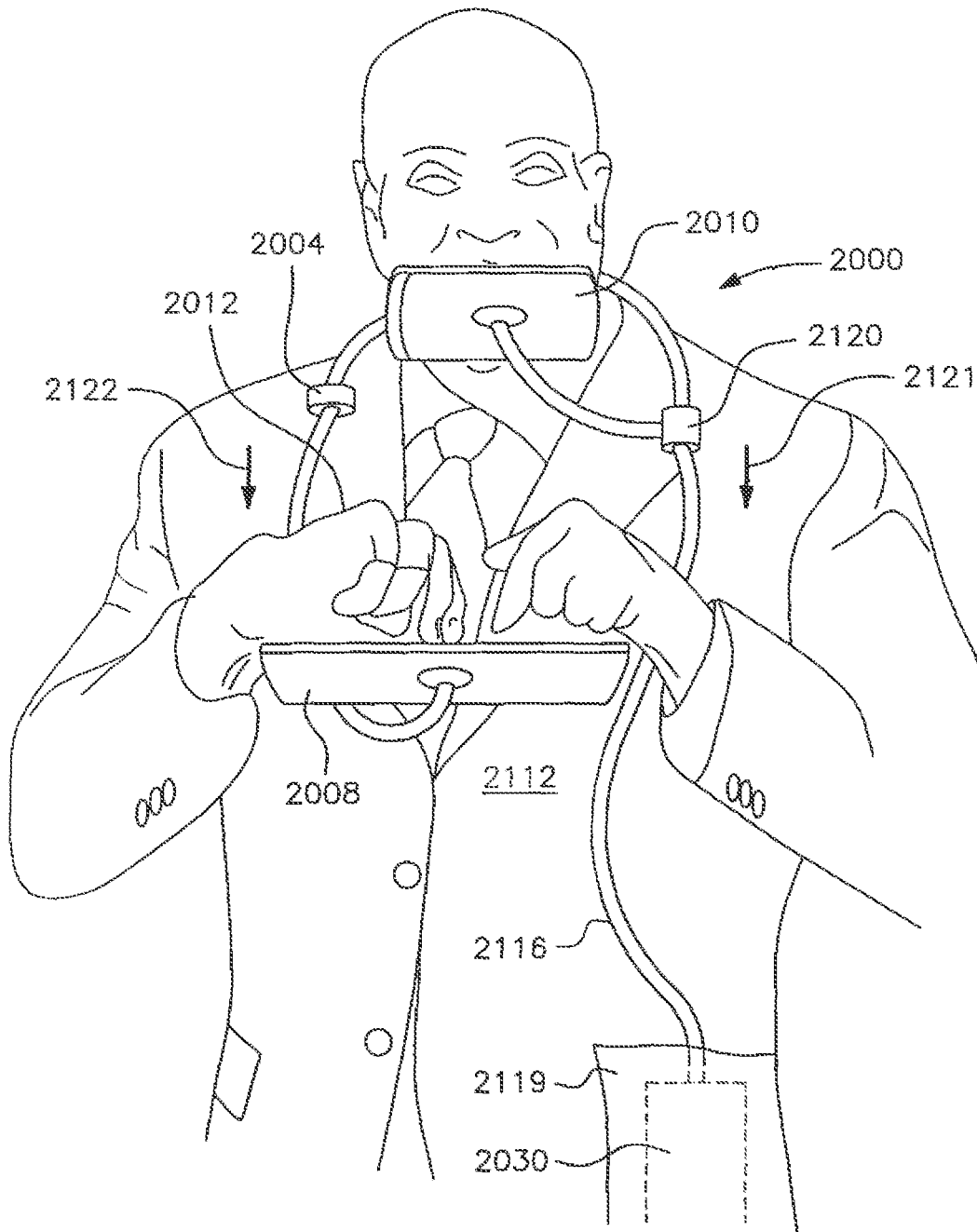

FIG. 45B

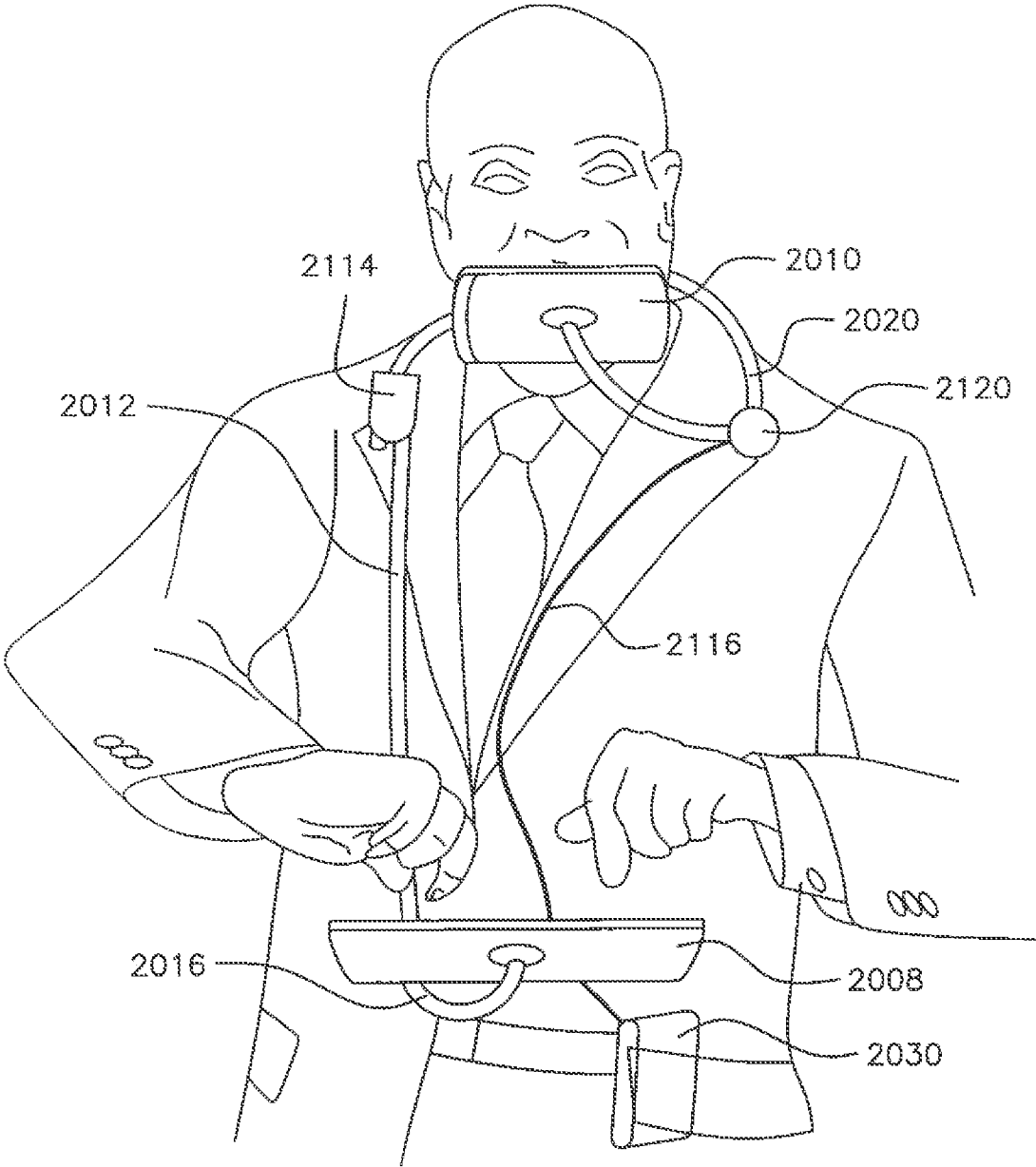

FIG. 45C

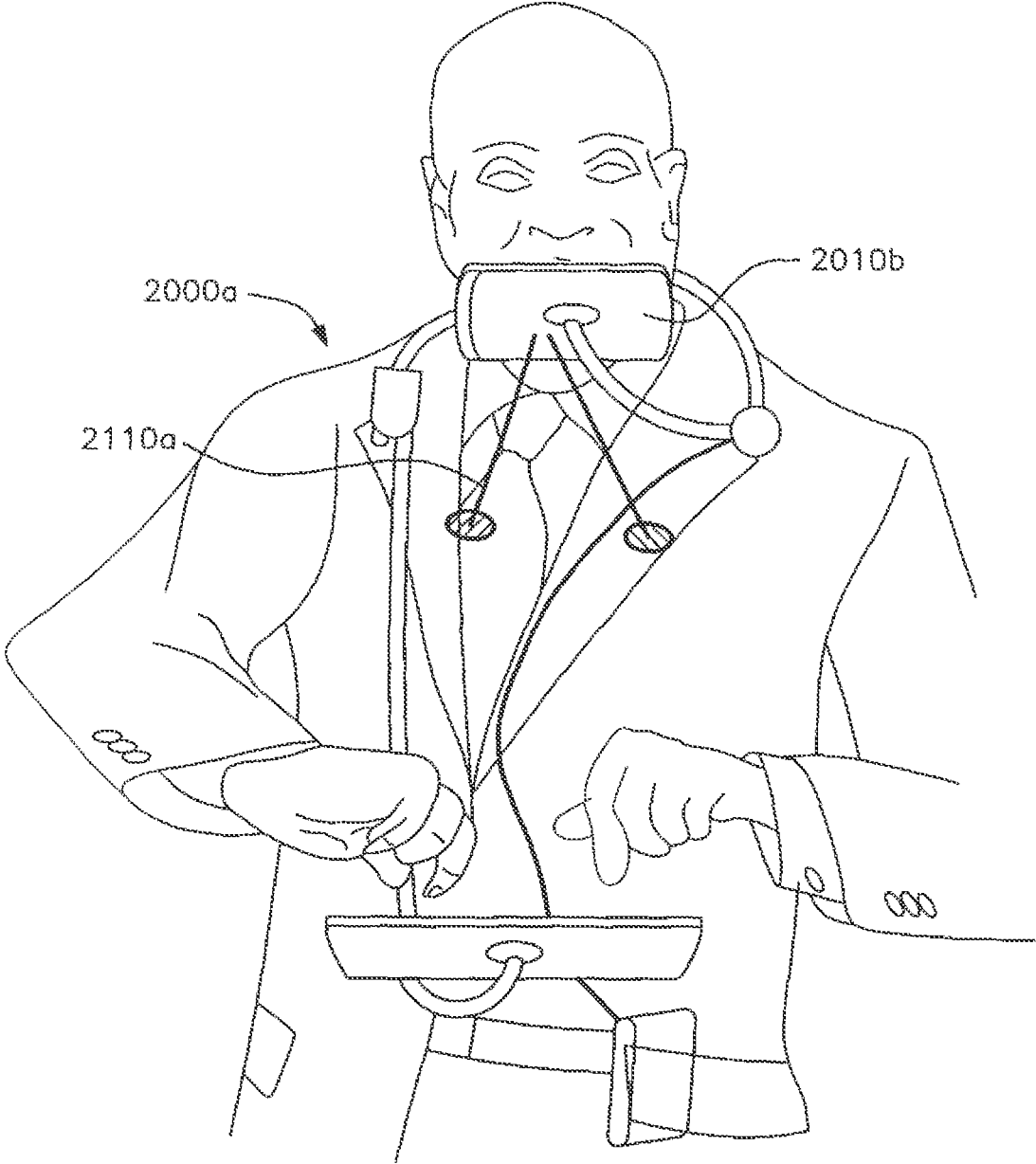

FIG. 45D

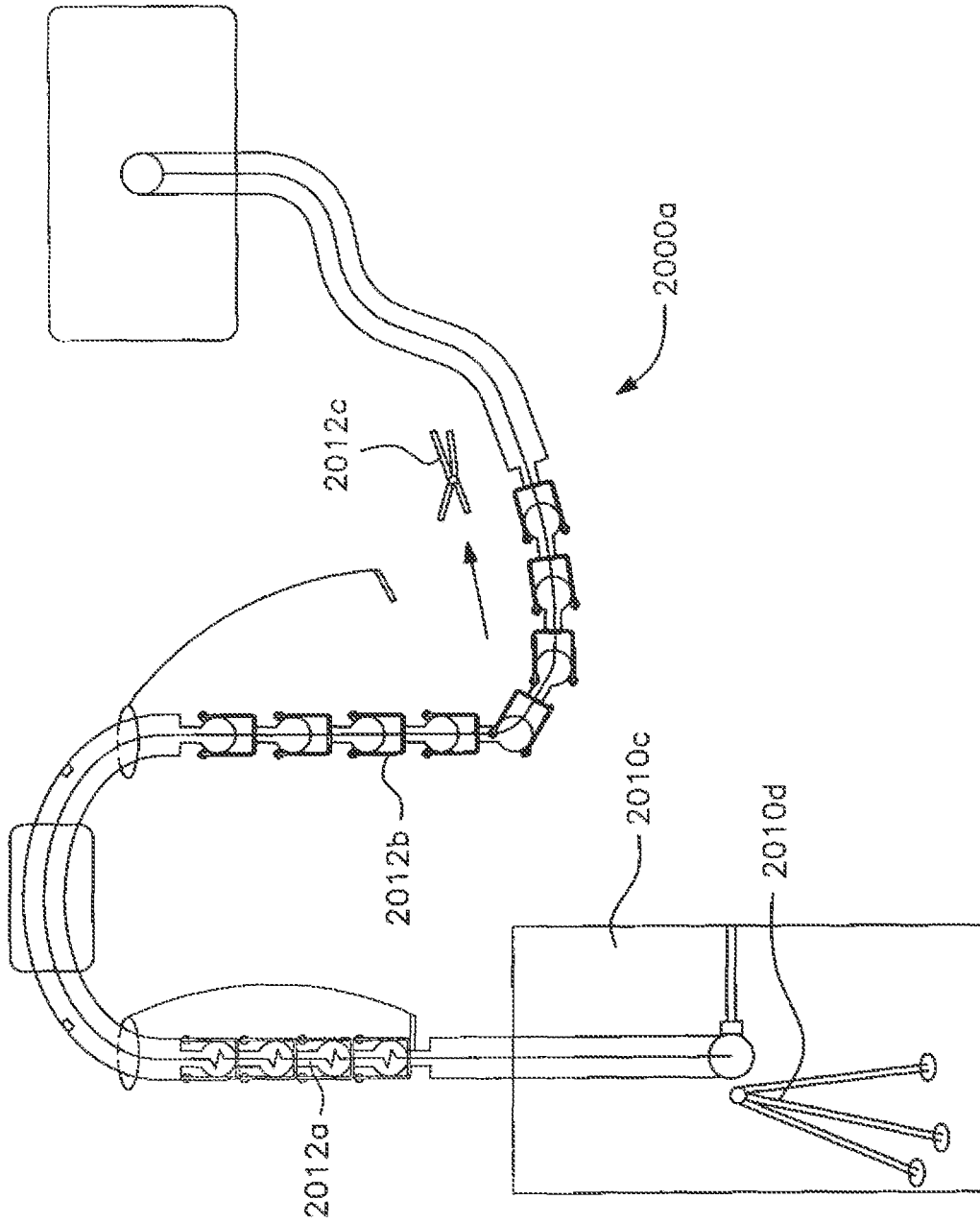

FIG. 45E

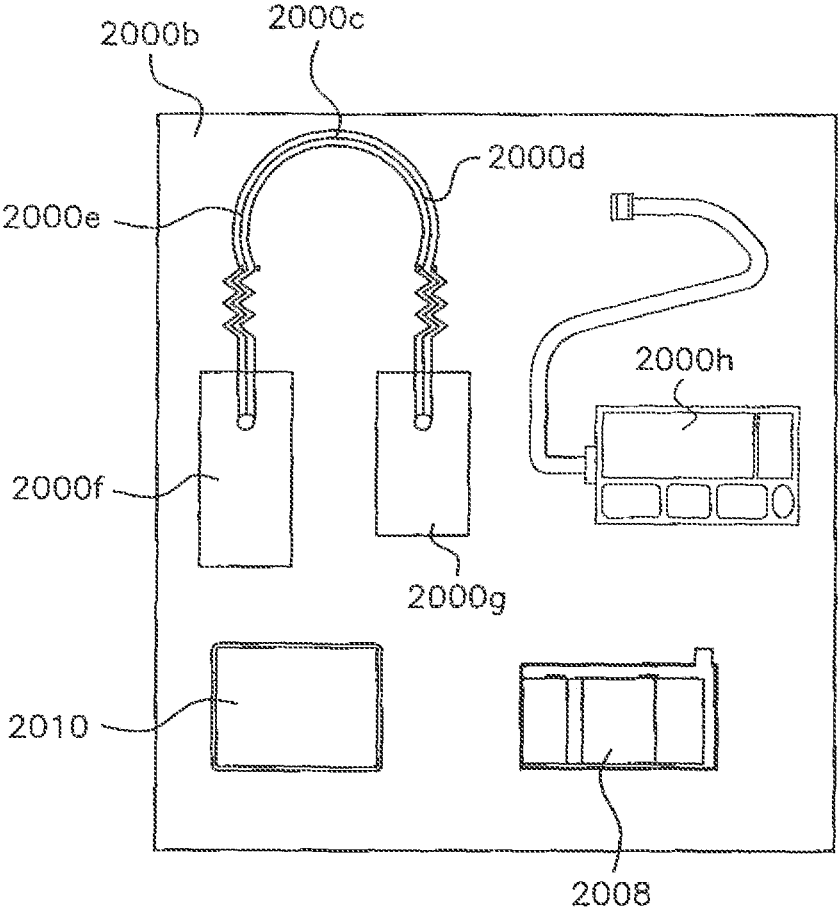

FIG. 45F

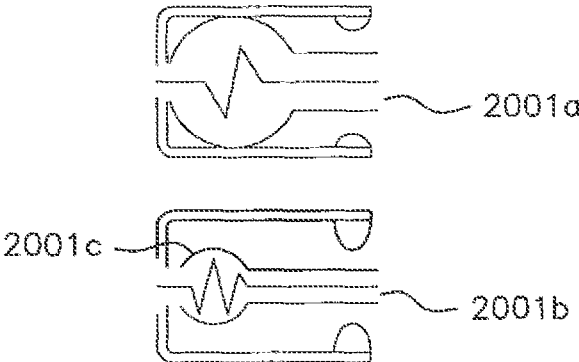

FIG. 45G

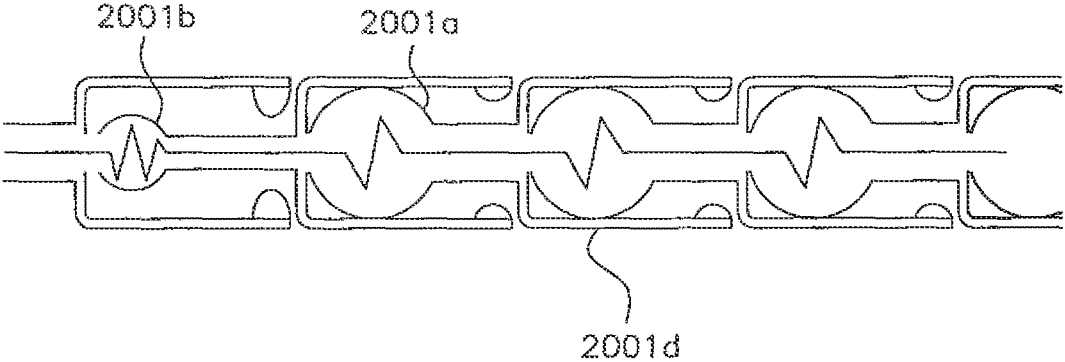

FIG. 46

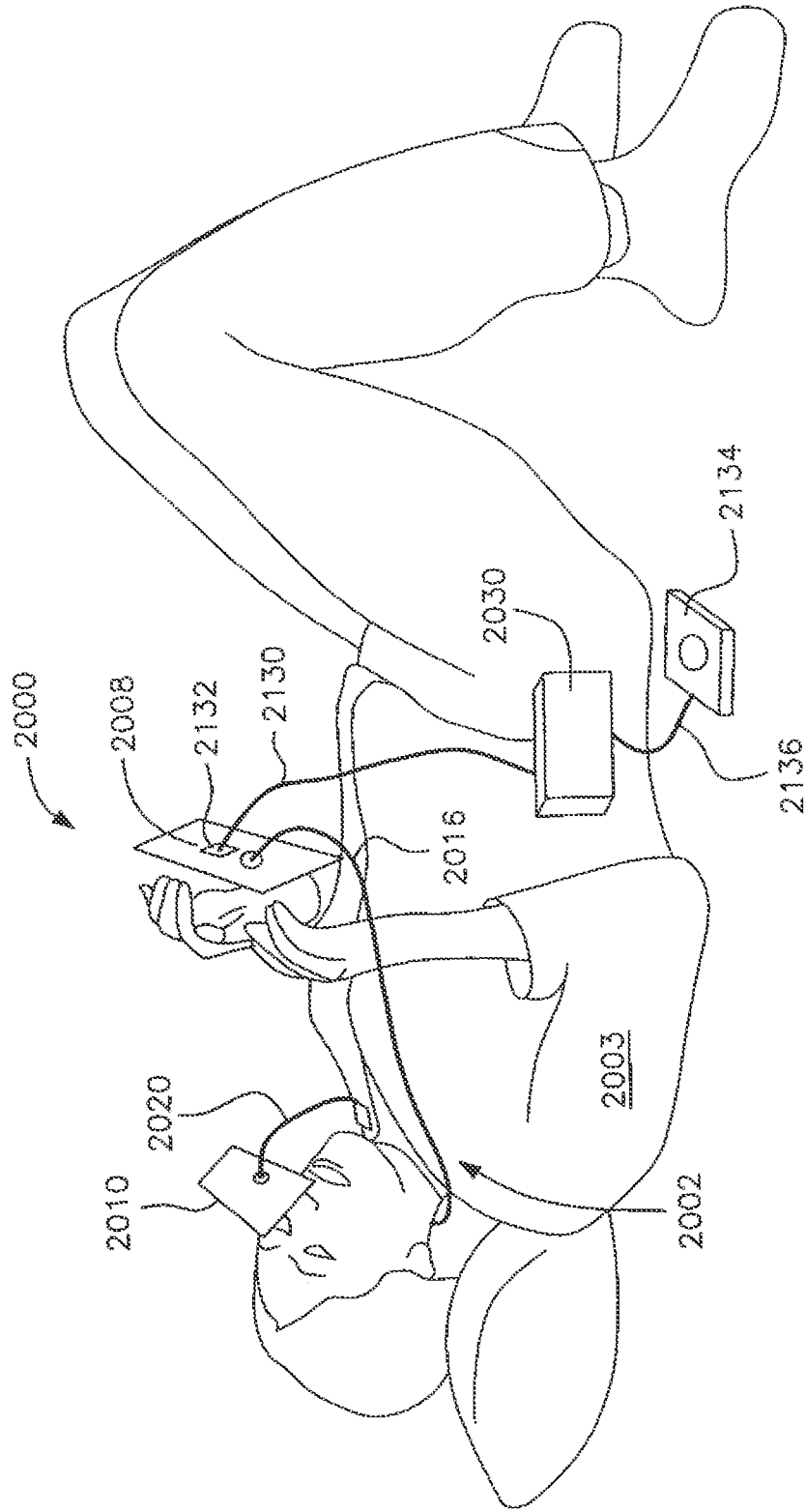

FIG. 47

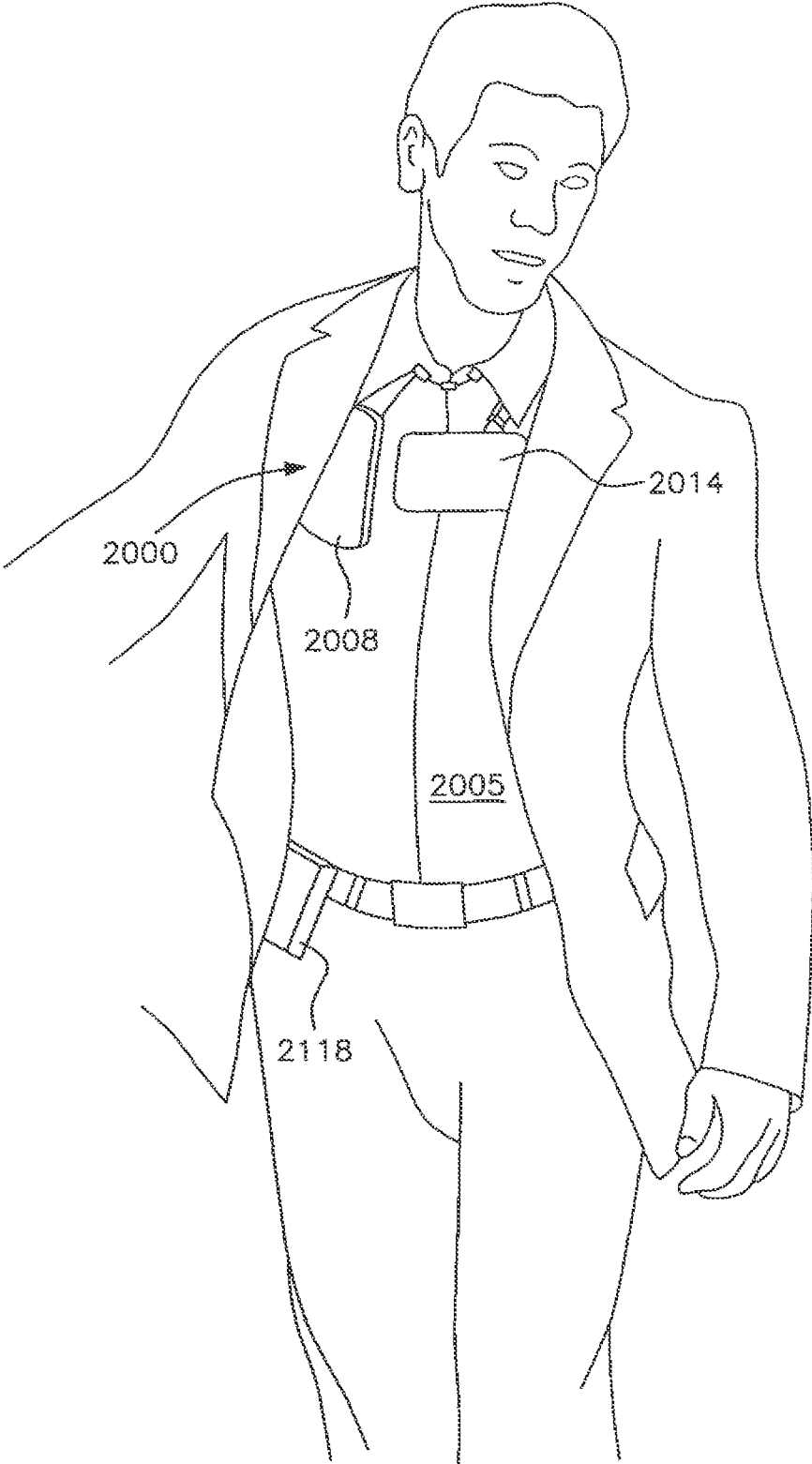

FIG. 48

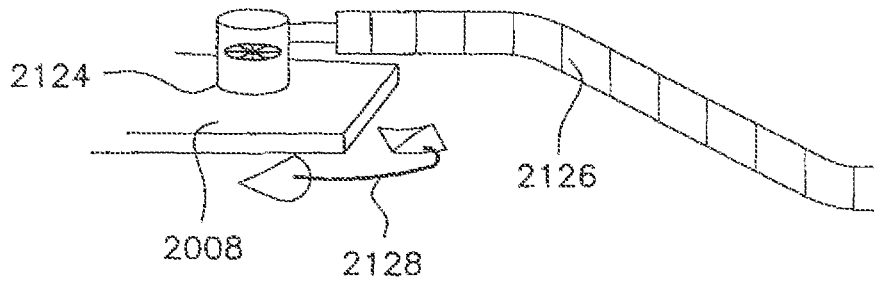

FIG. 48A

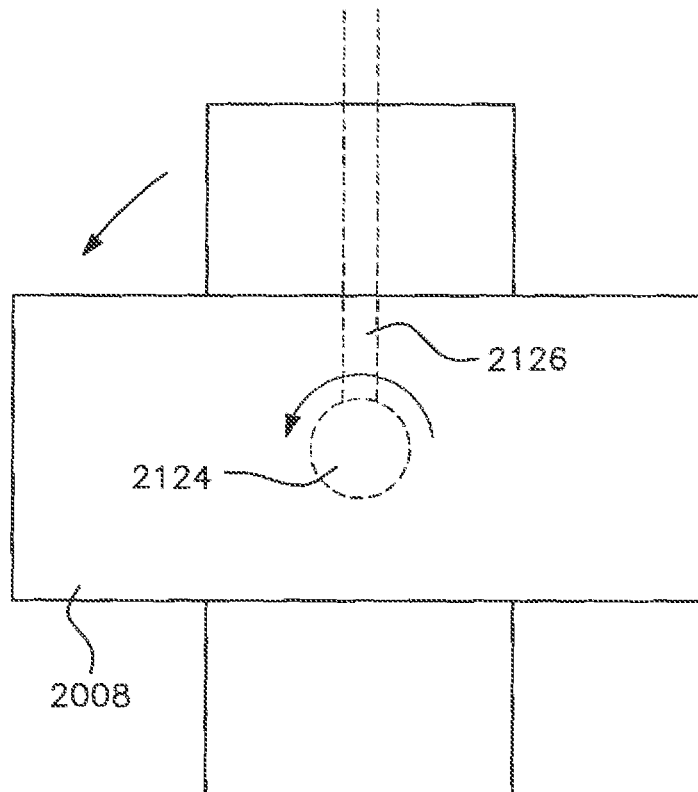

FIG. 49

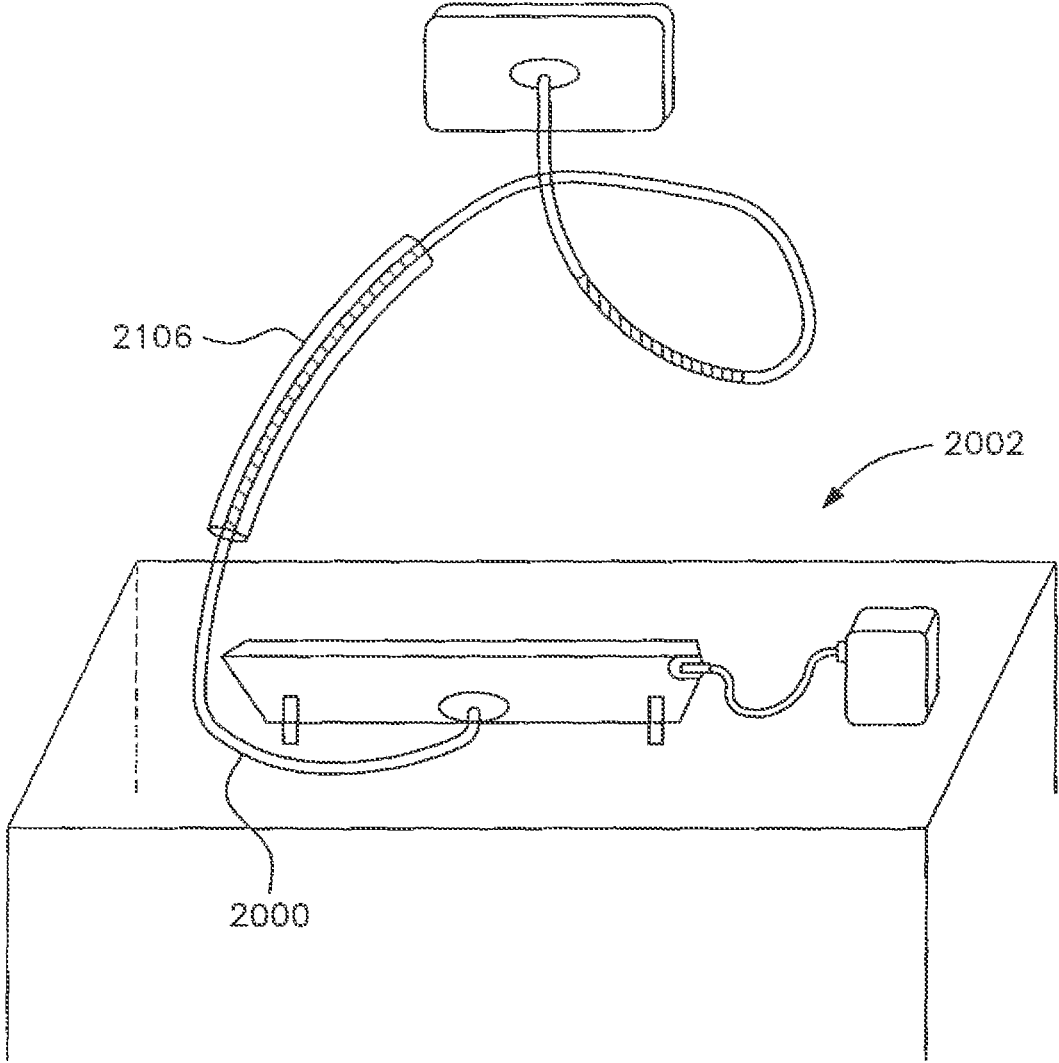

FIG. 50A

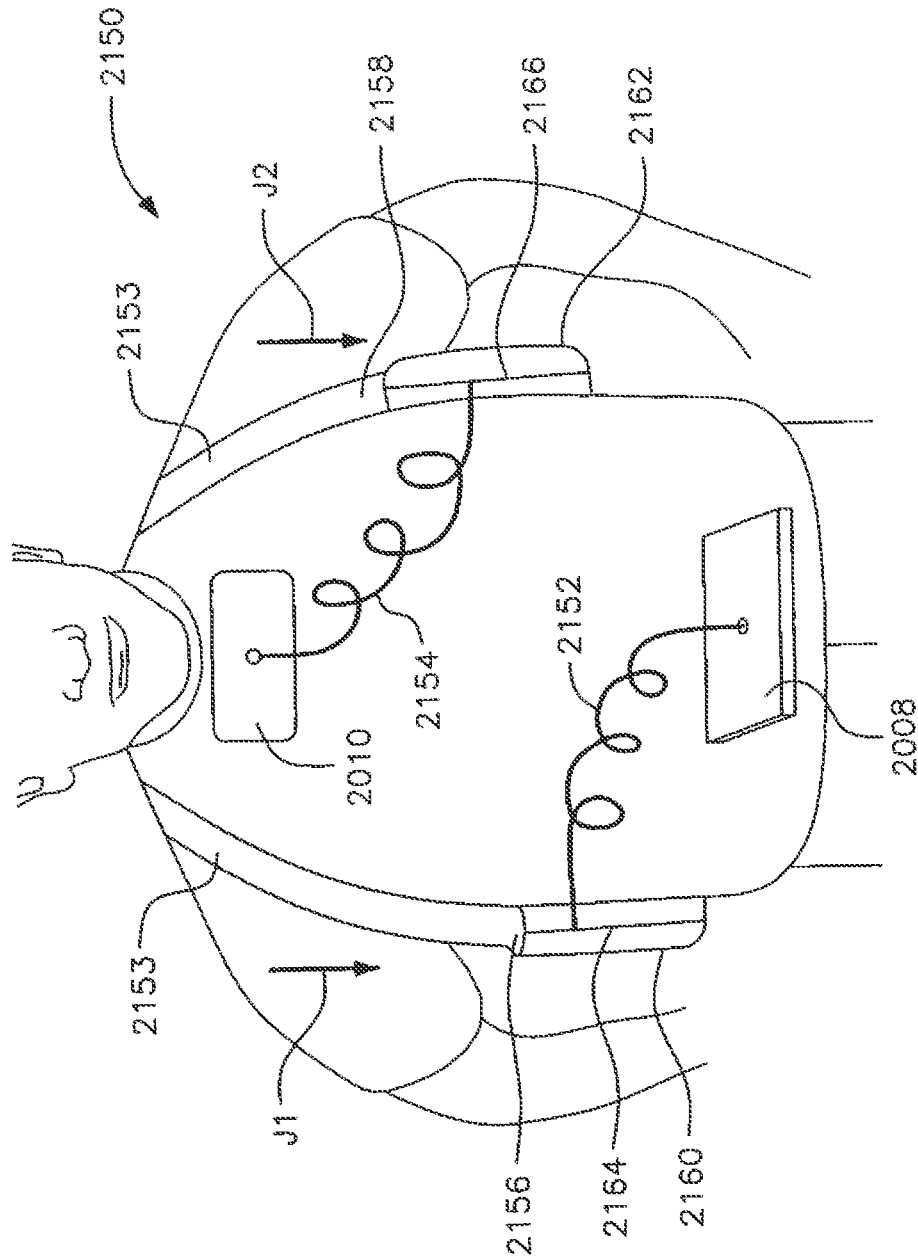

FIG. 50B

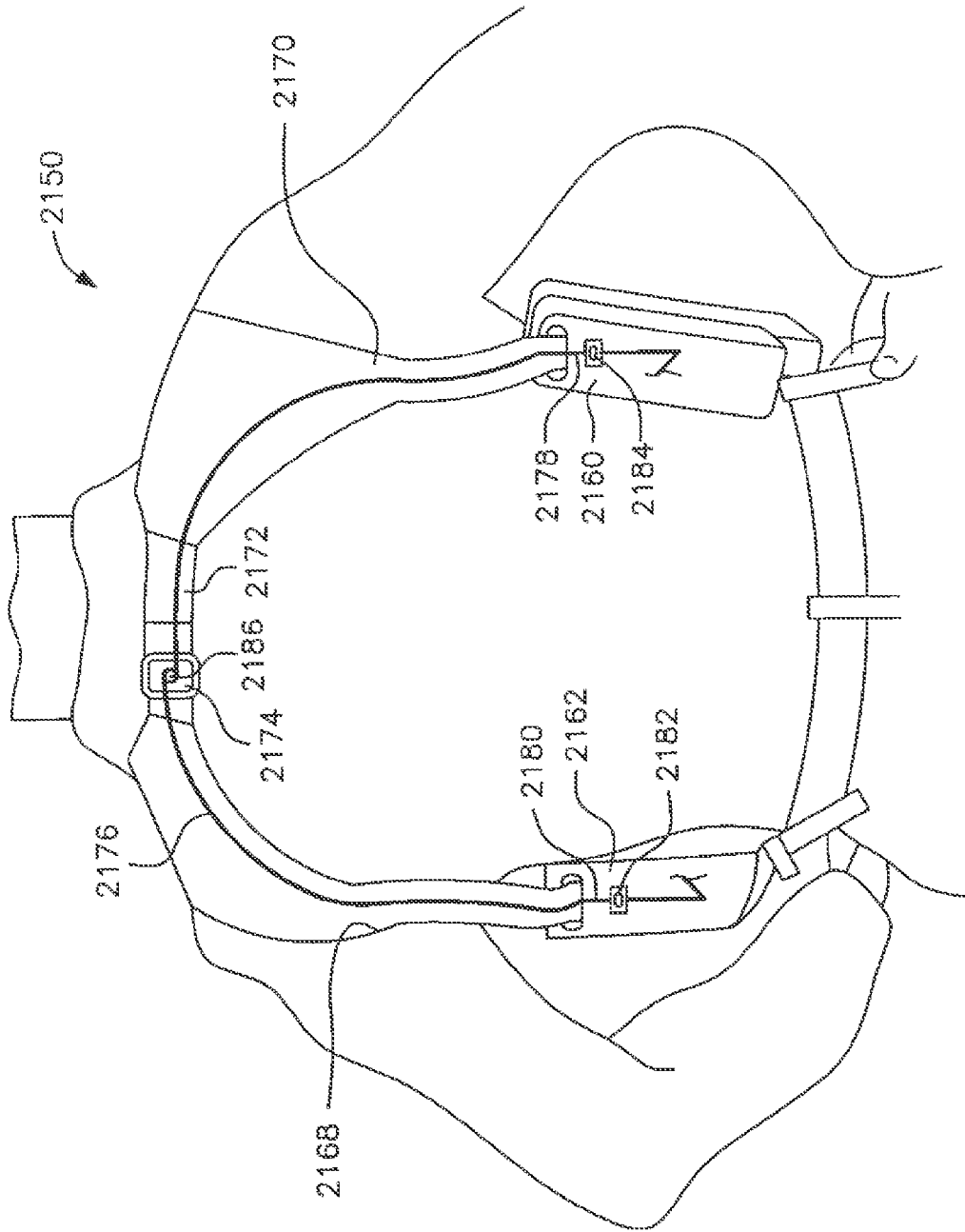

FIG. 50C

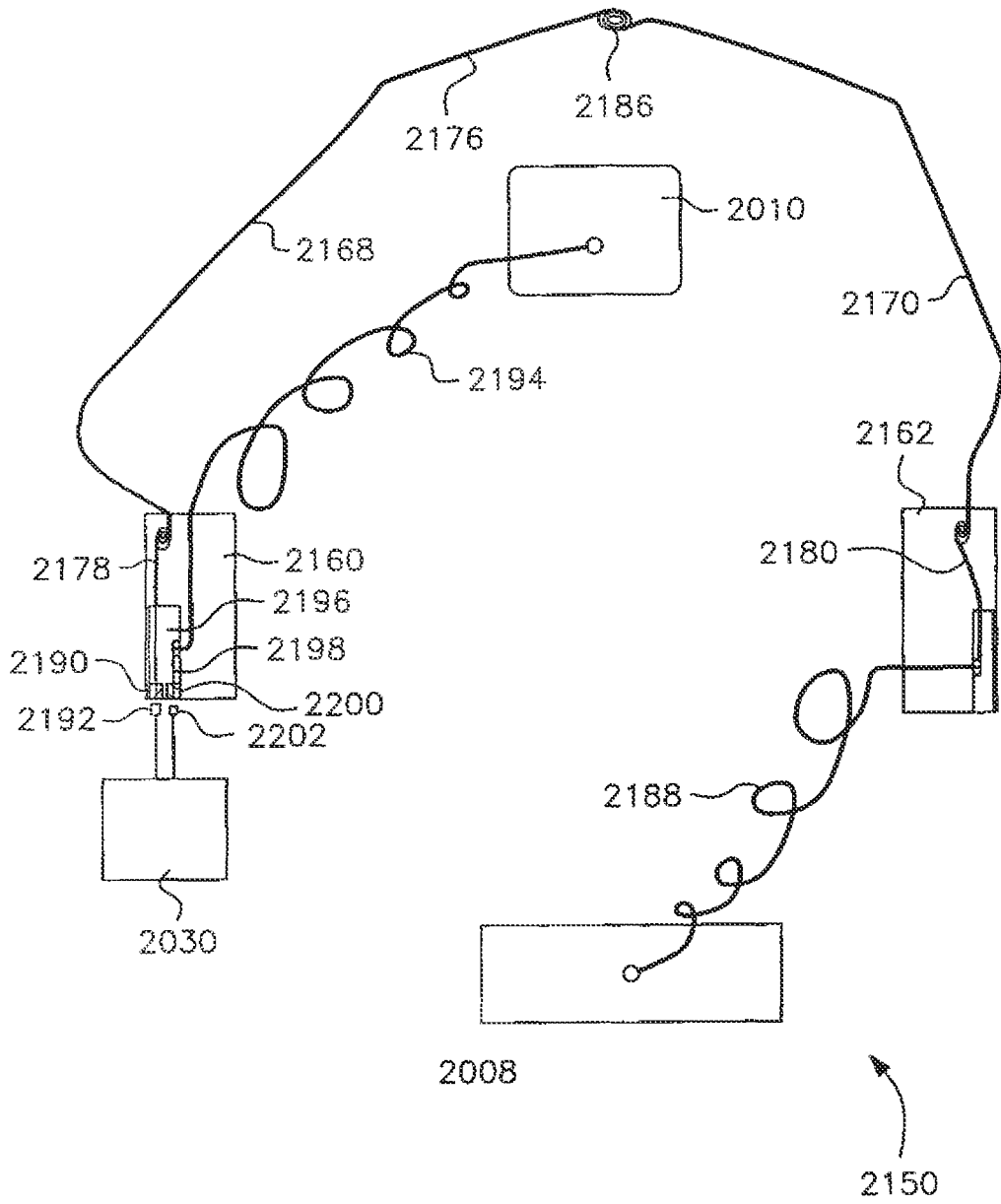

FIG. 50D

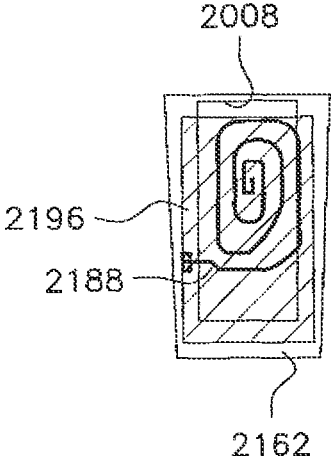

FIG. 50E

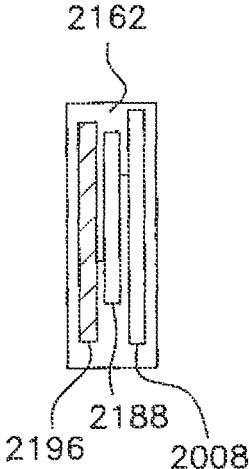

FIG. 51

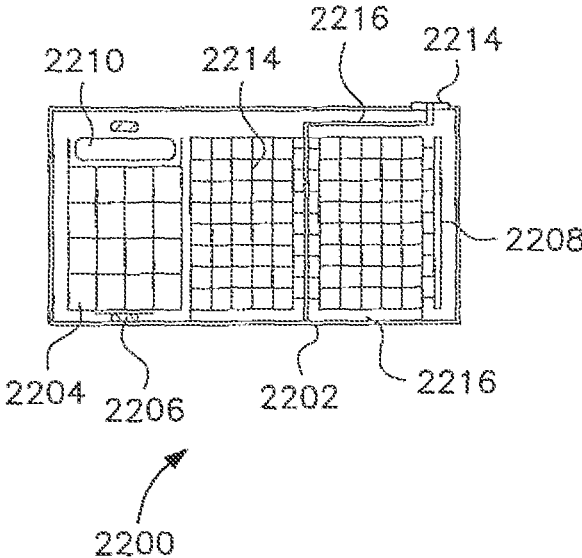

FIG. 51A

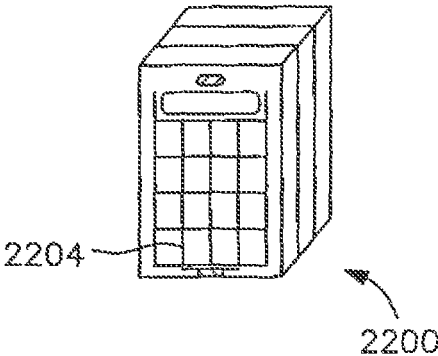

FIG. 52

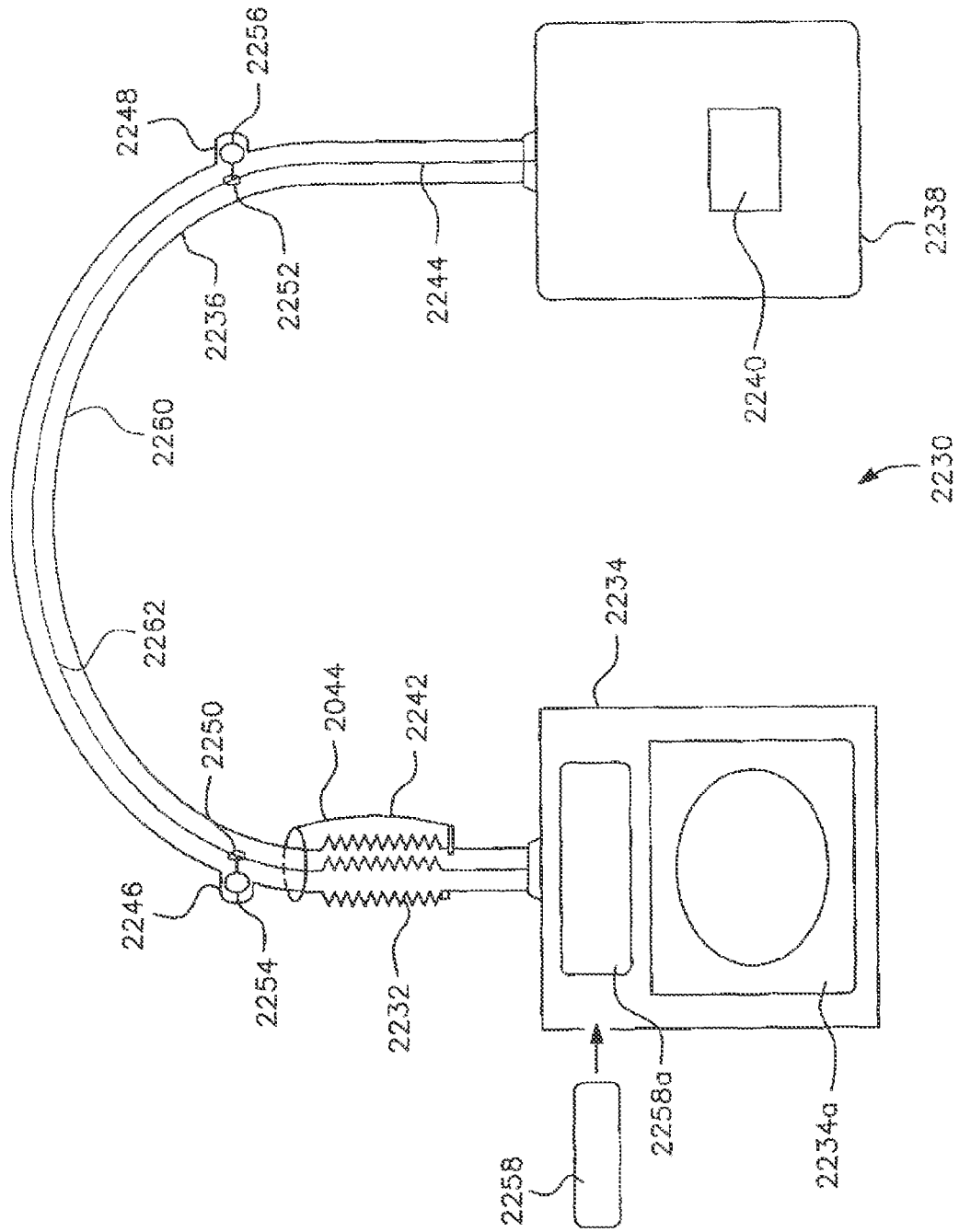

FIG. 53

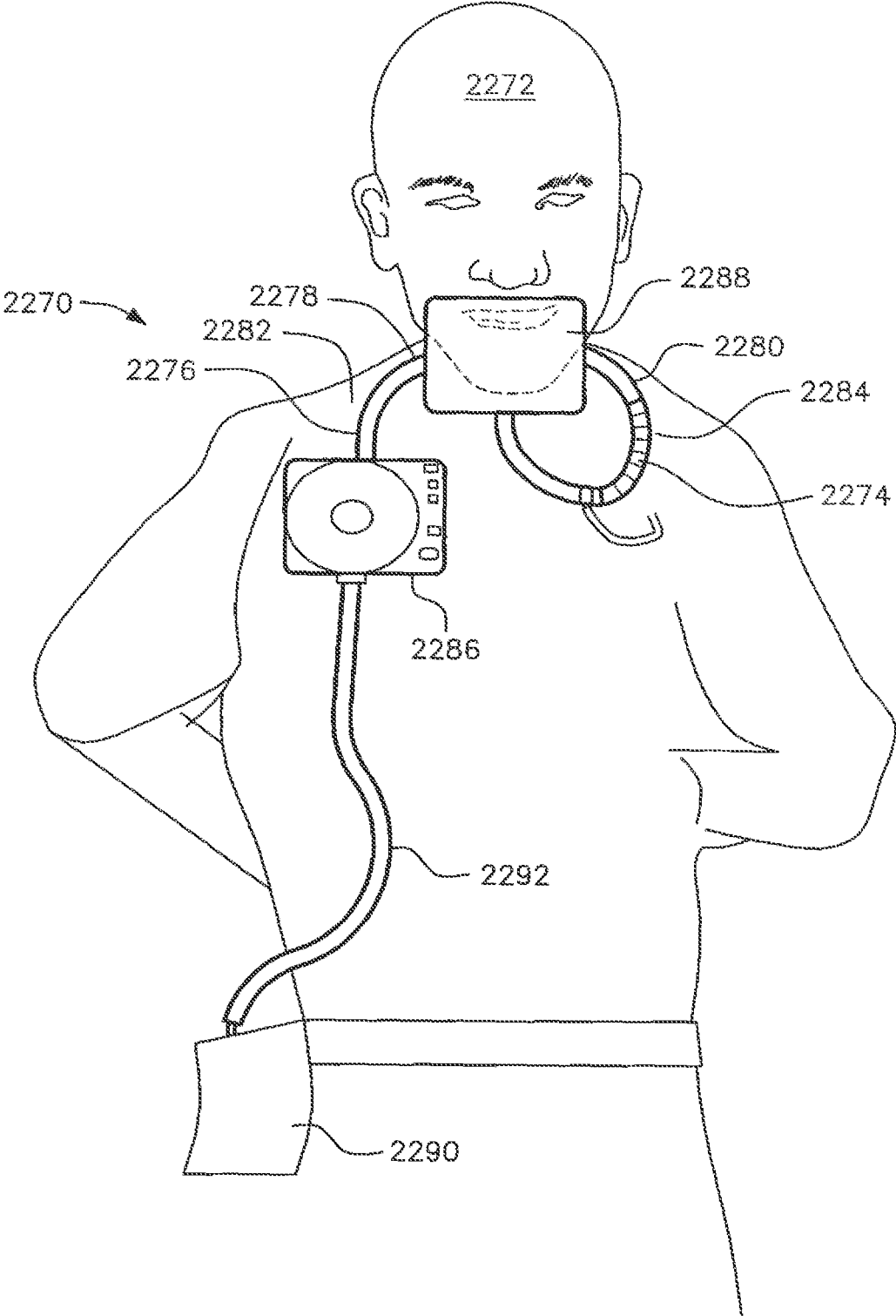

FIG. 54

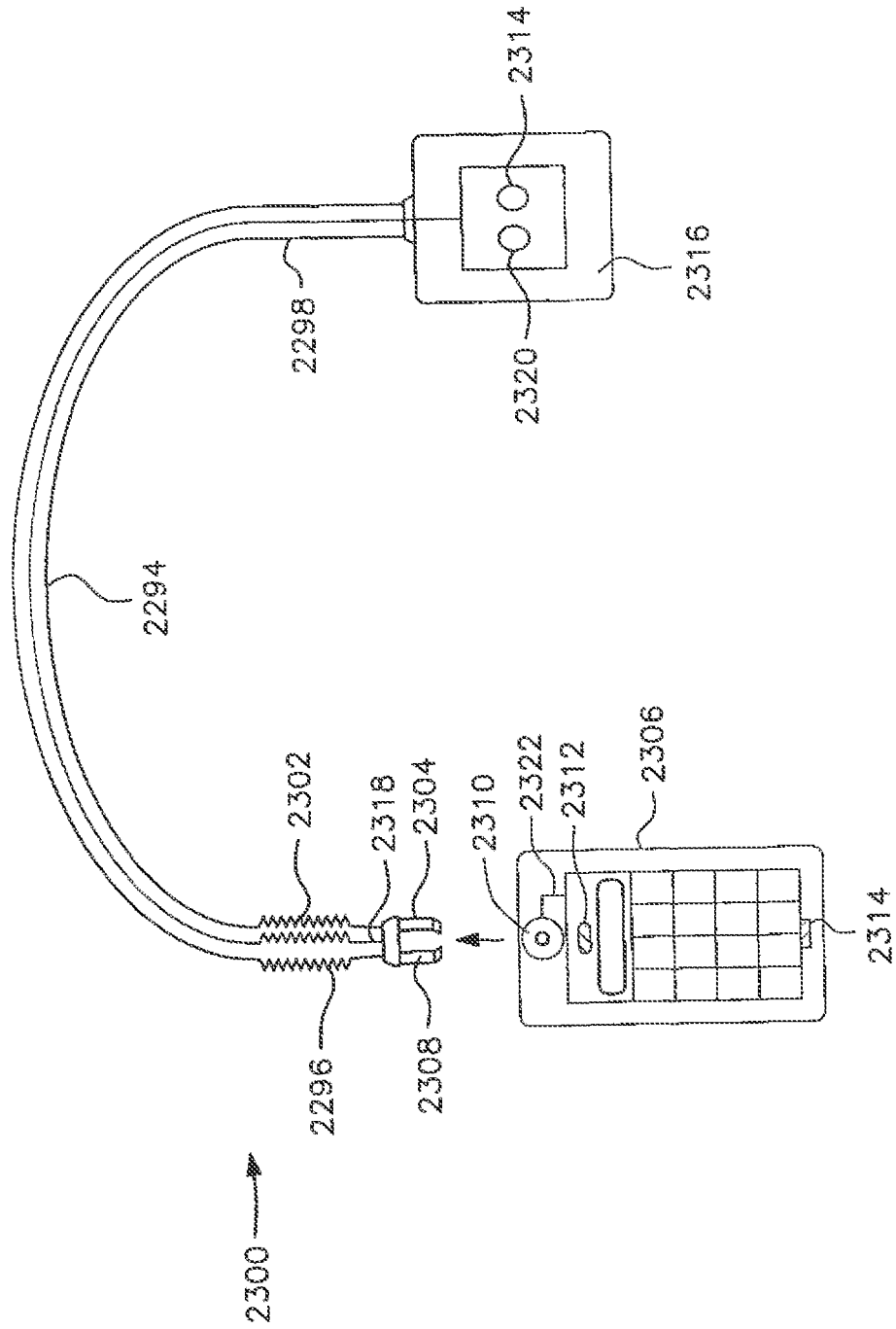

FIG. 54A

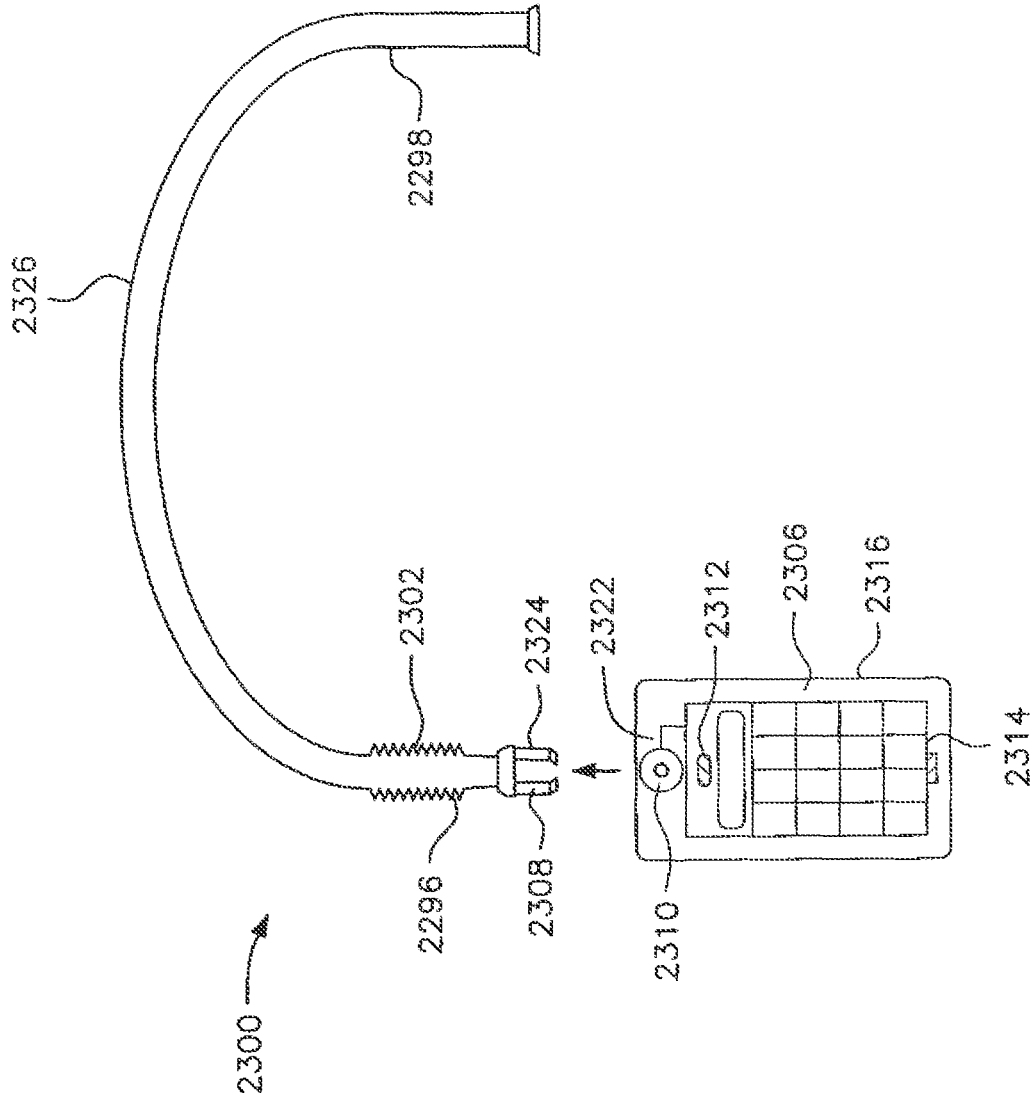

FIG. 54B

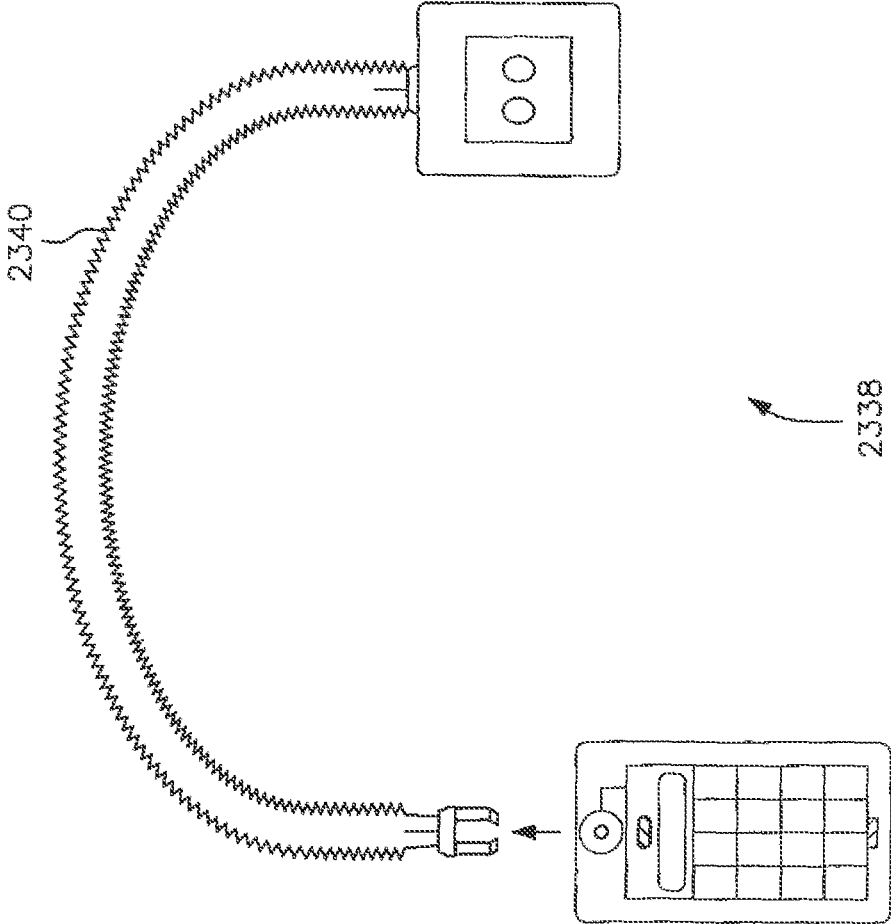

FIG. 55A

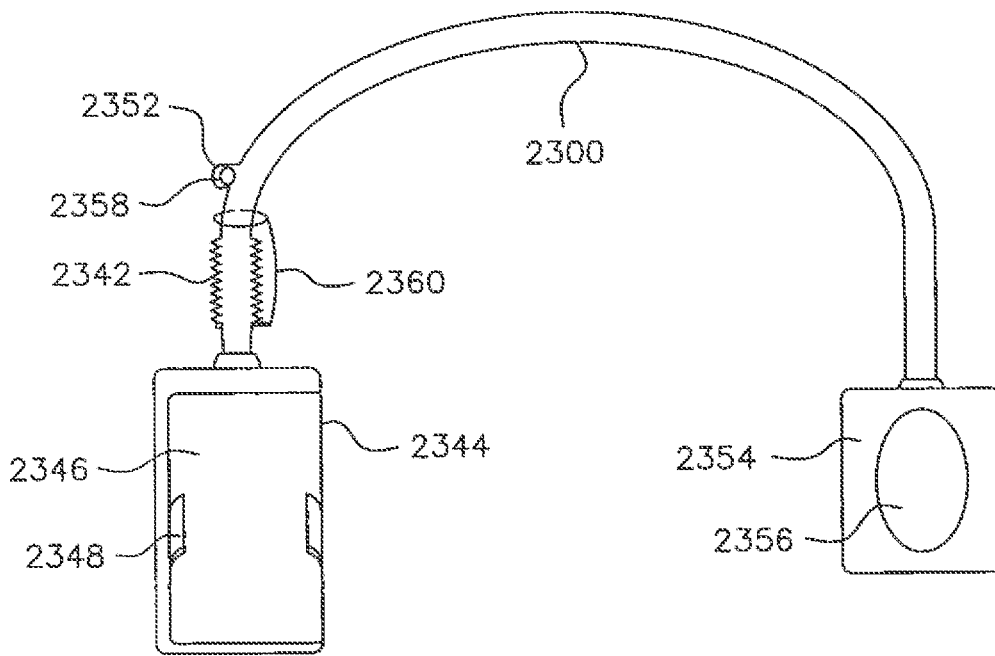

FIG. 55B

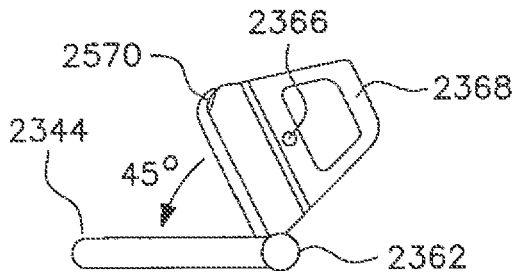

FIG. 55D

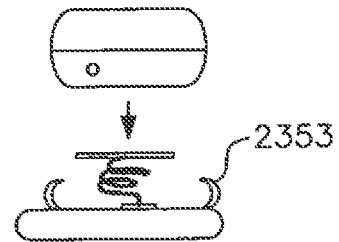

FIG. 55C

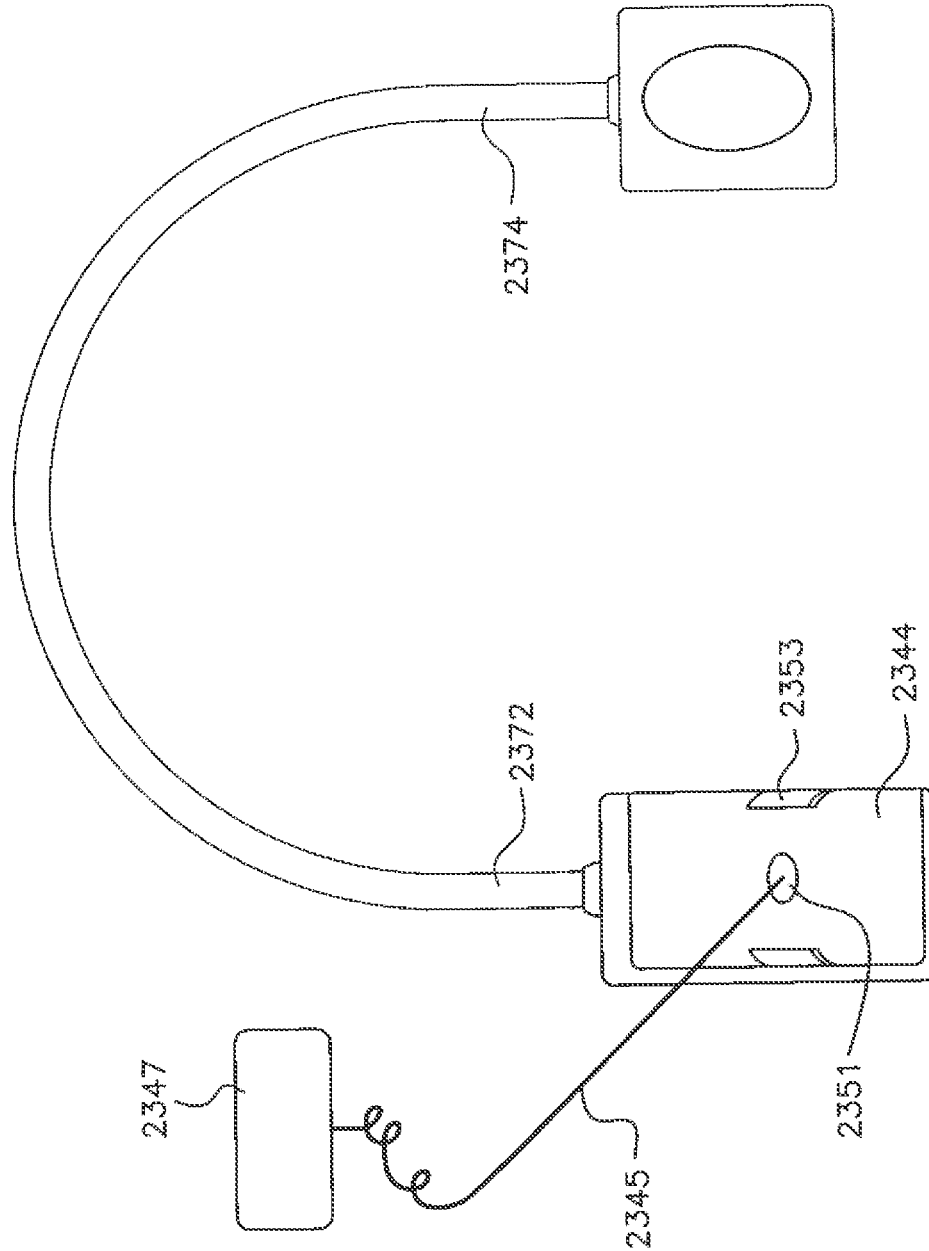

FIG. 56

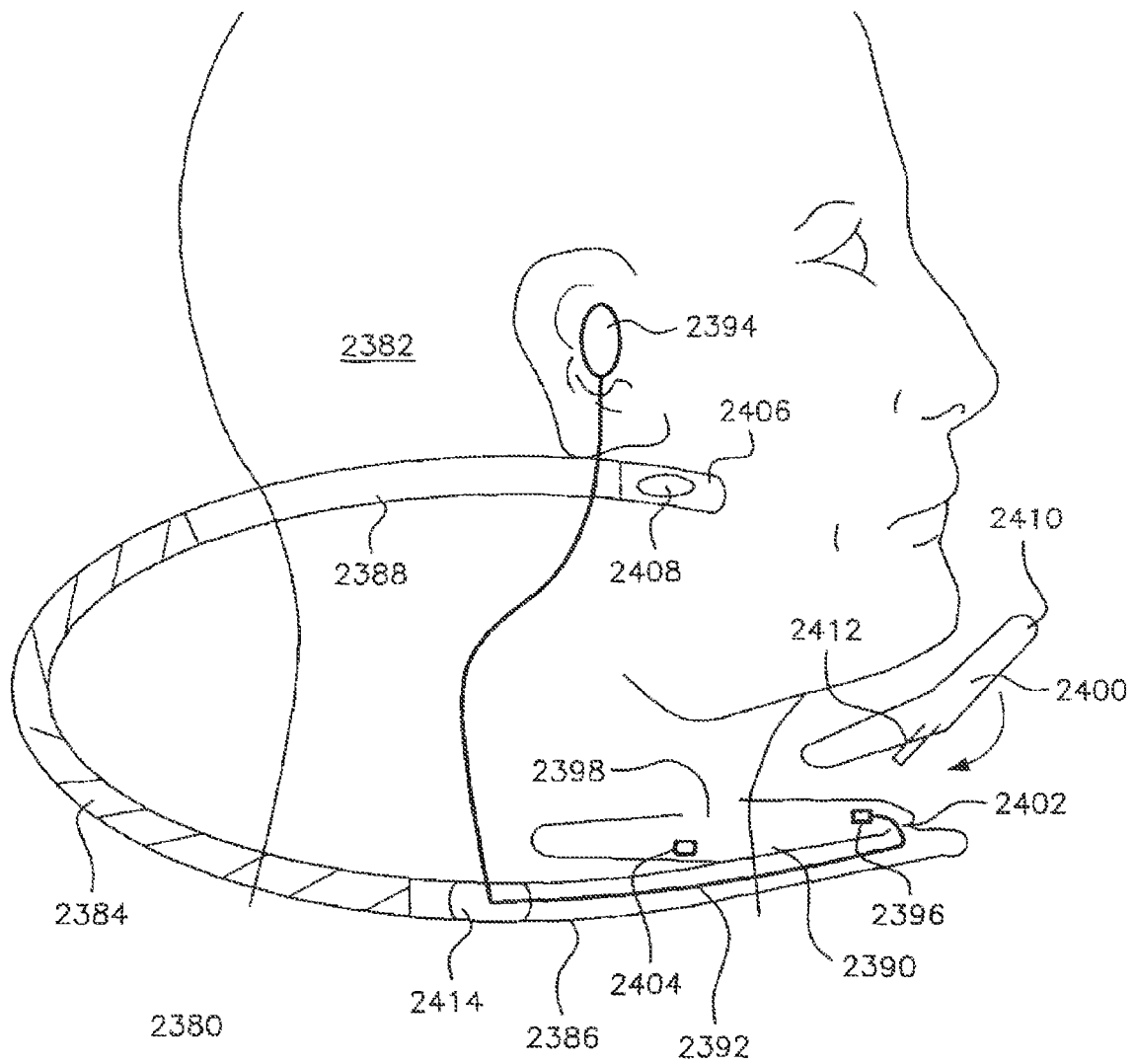

FIG. 56A

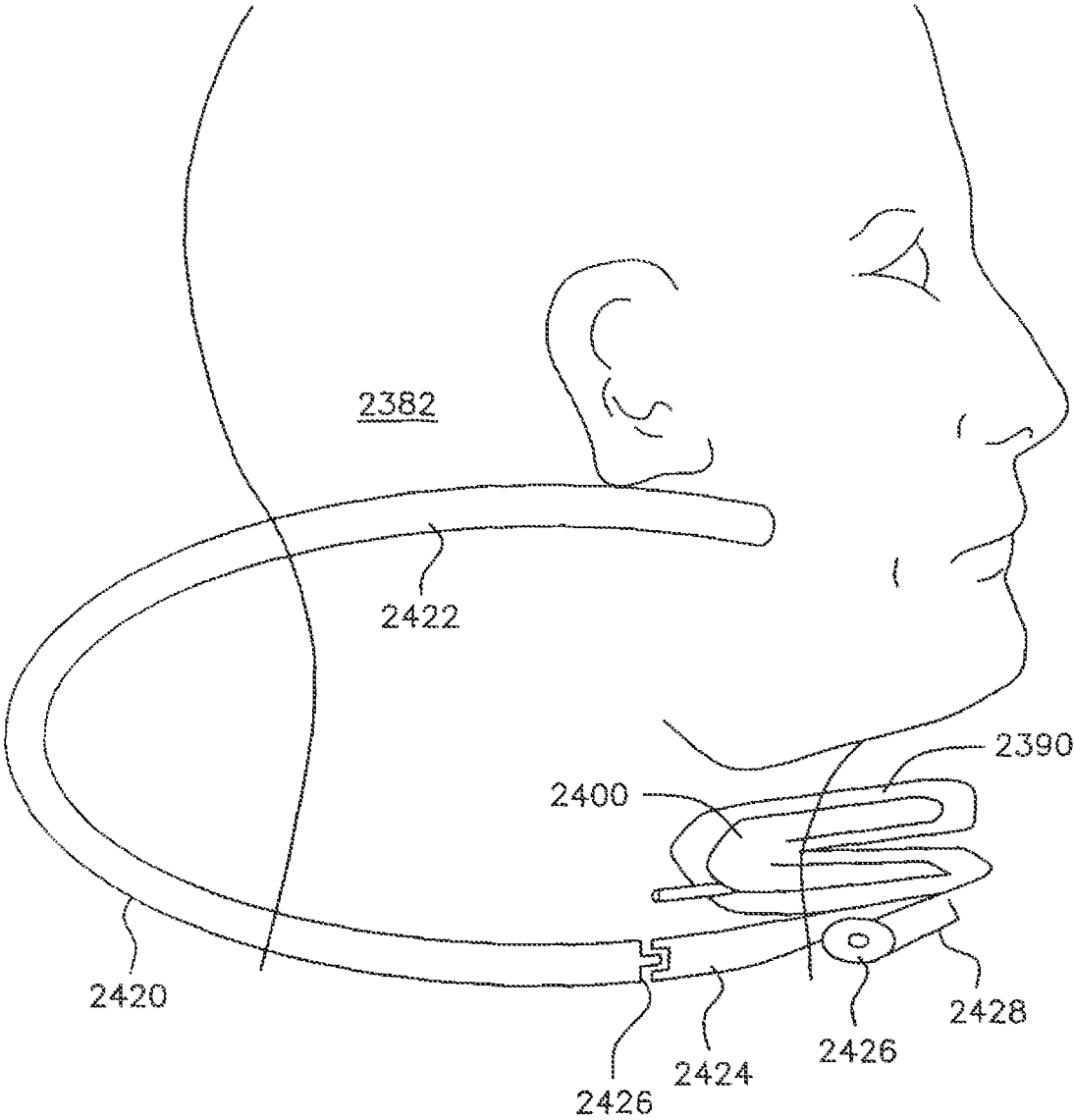

FIG. 57B

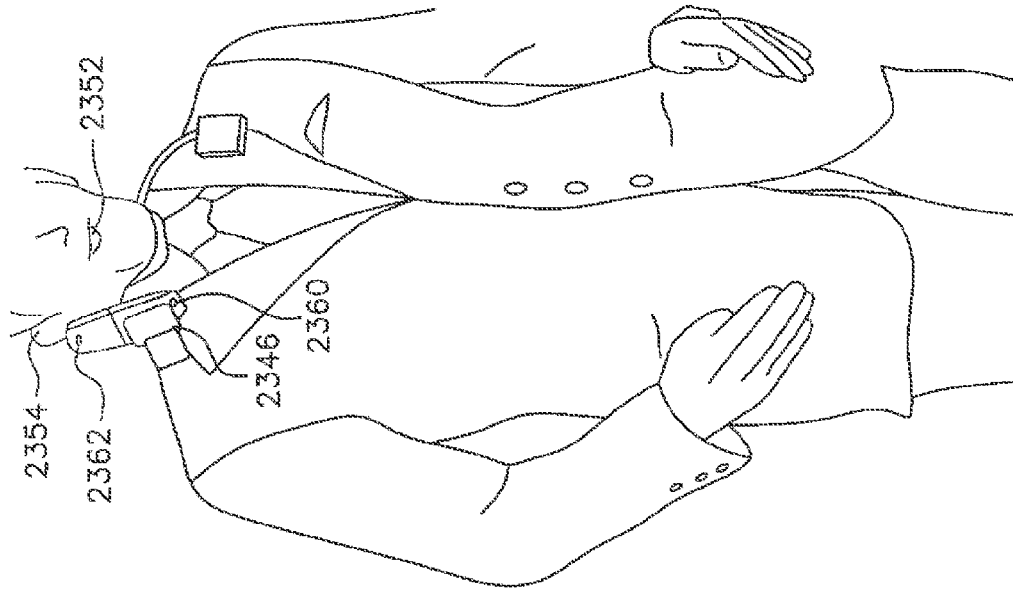

FIG. 57A

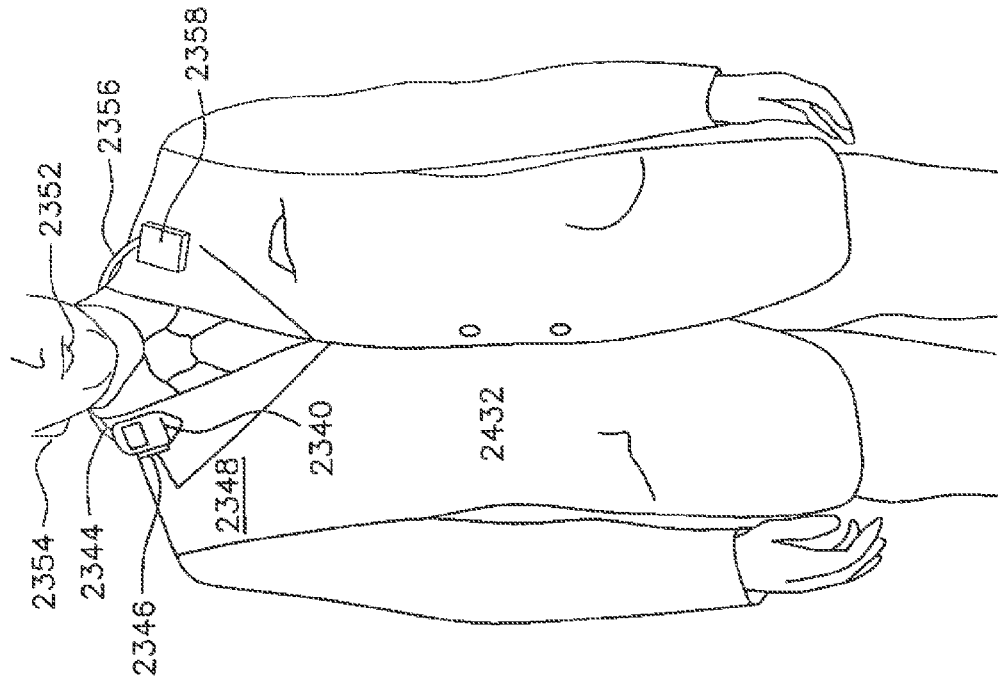

FIG. 57C



FIG. 58

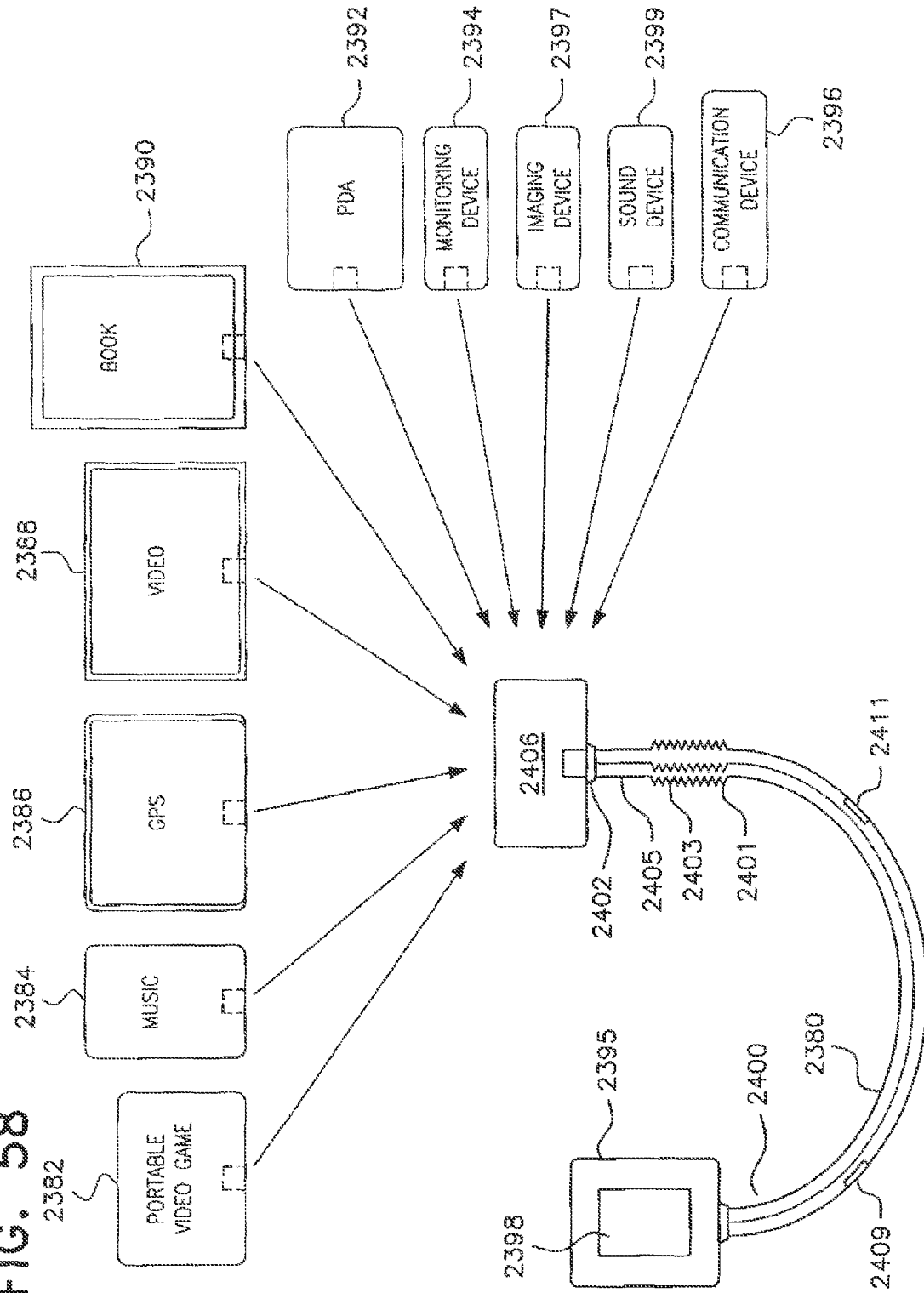

FIG. 59

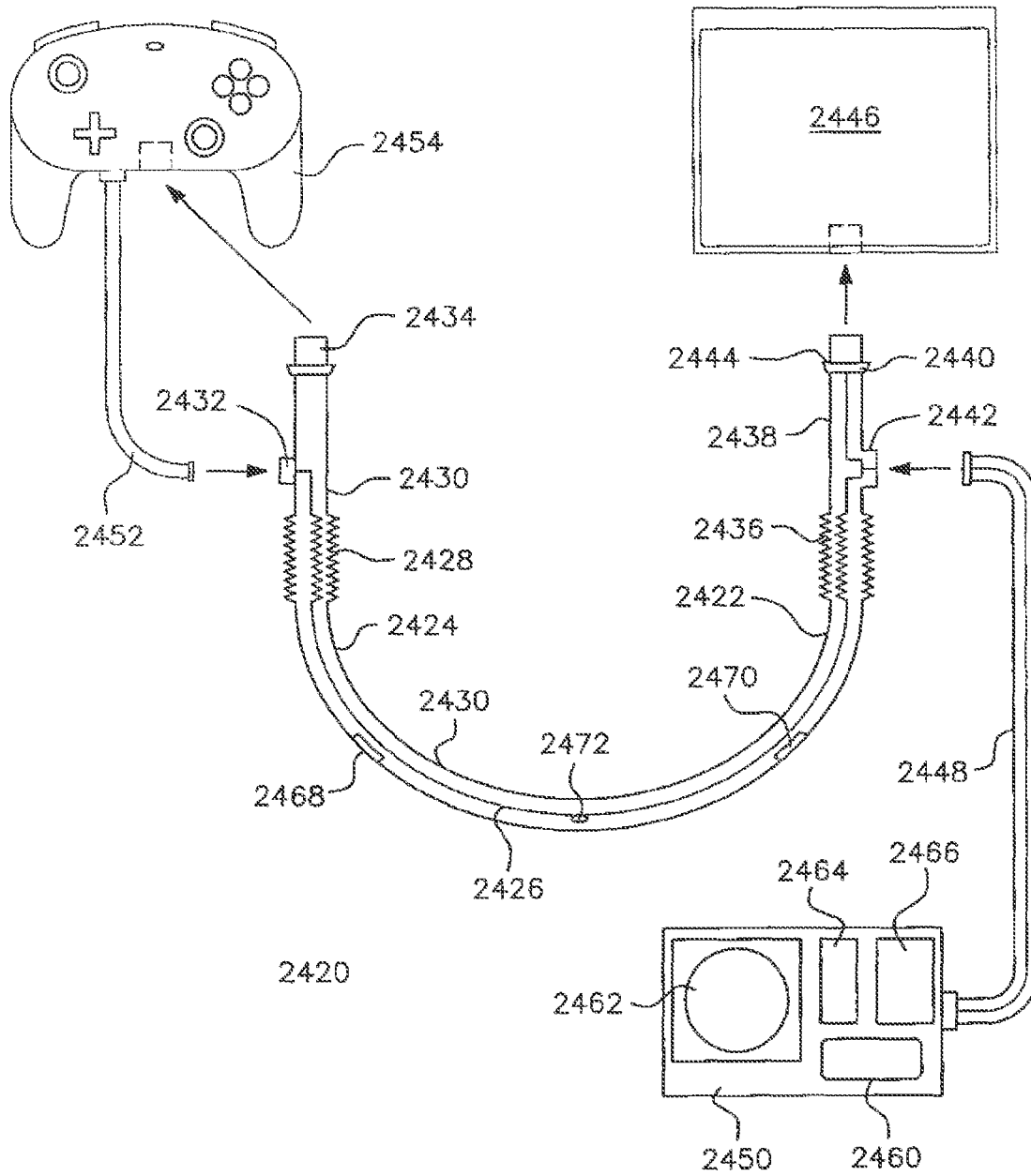

FIG. 60

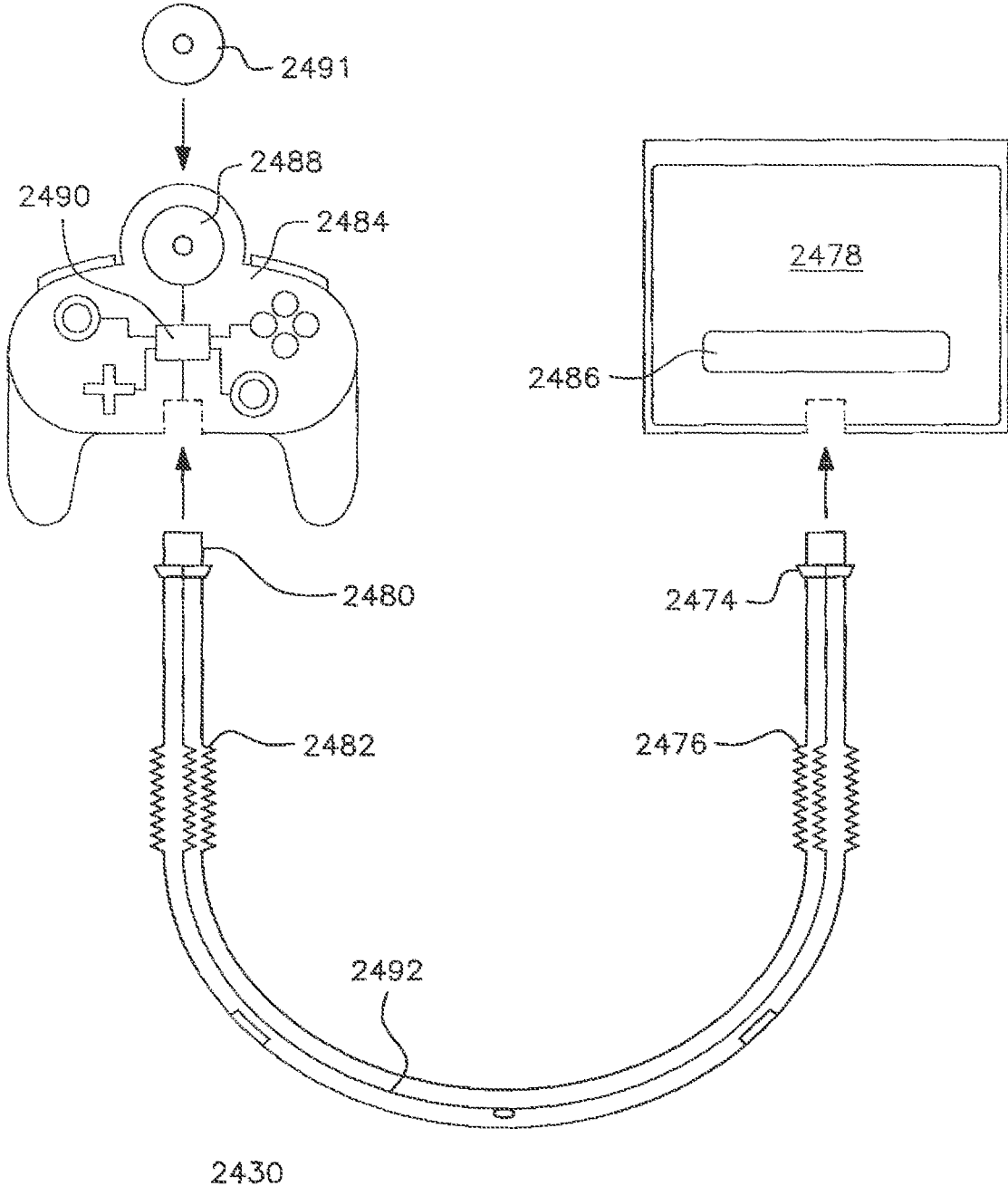

FIG. 61

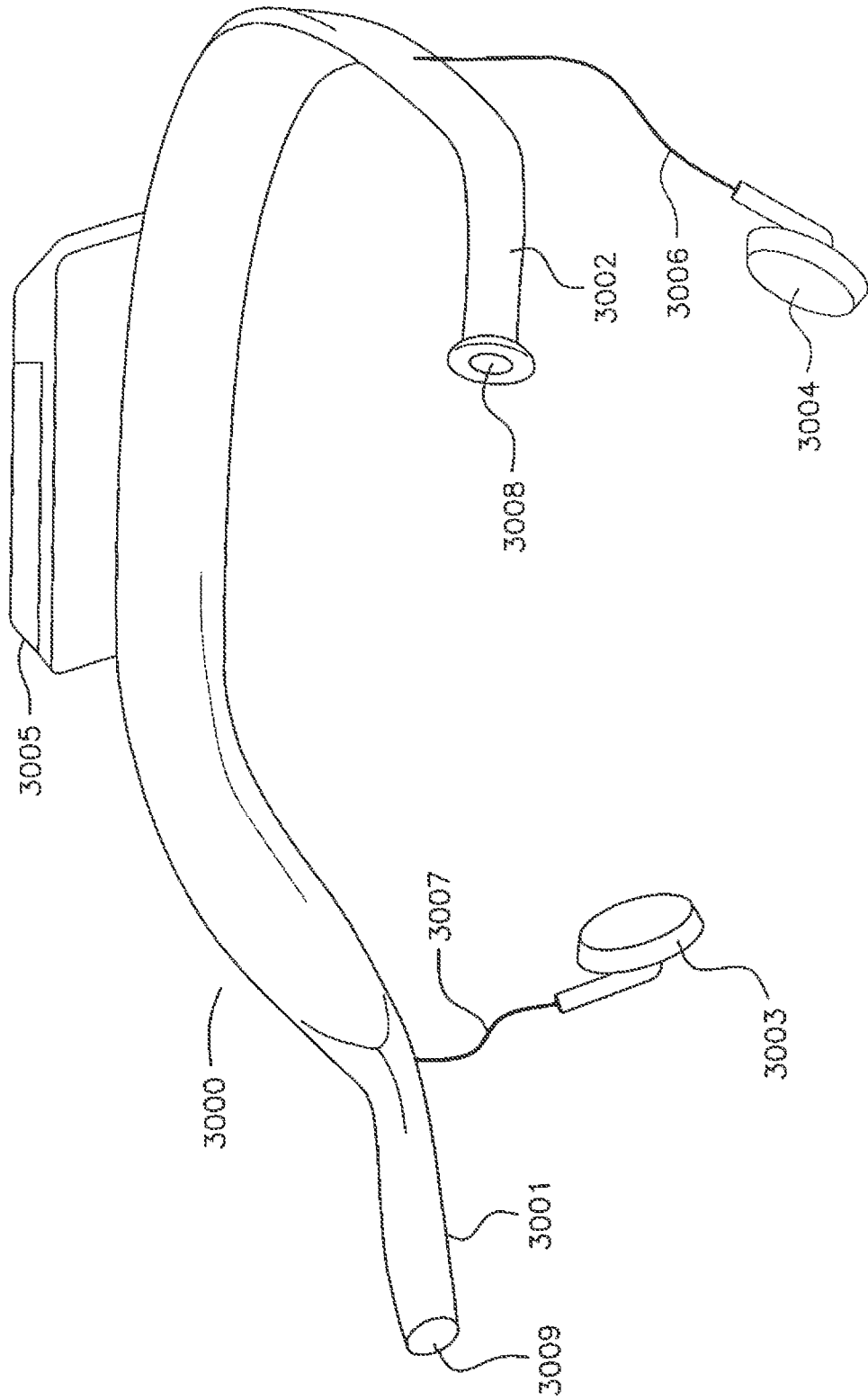

FIG. 62

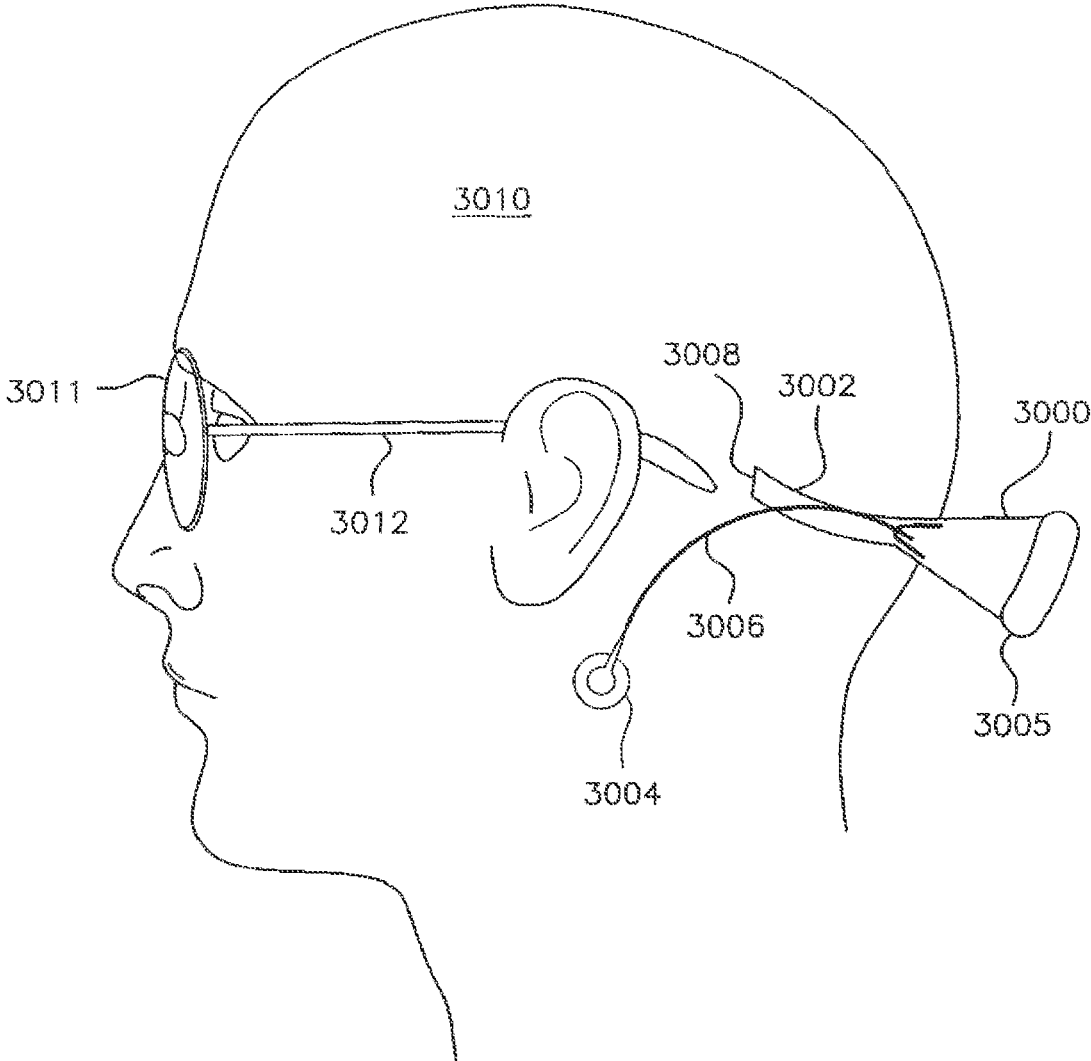

FIG. 63

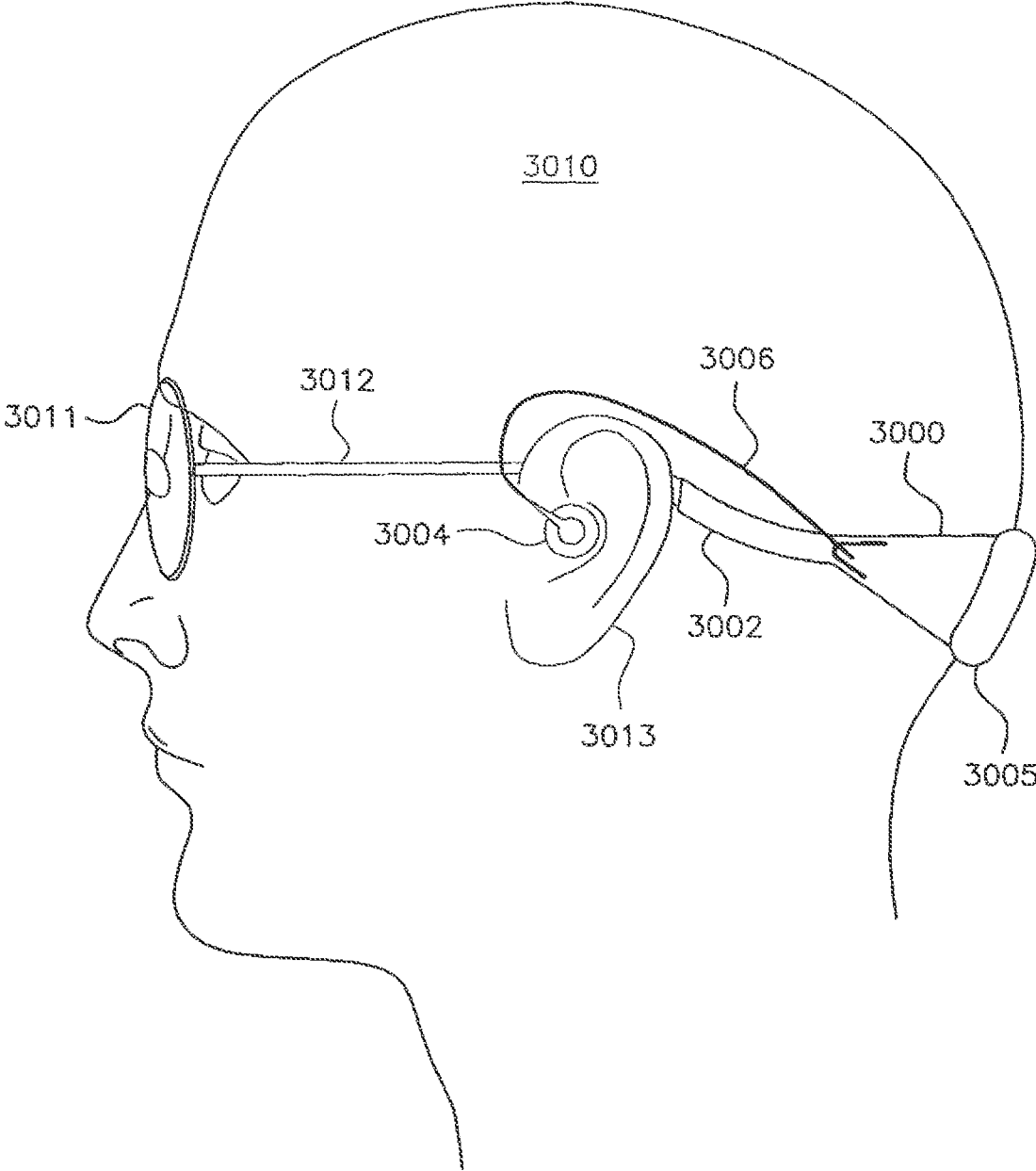

FIG. 64

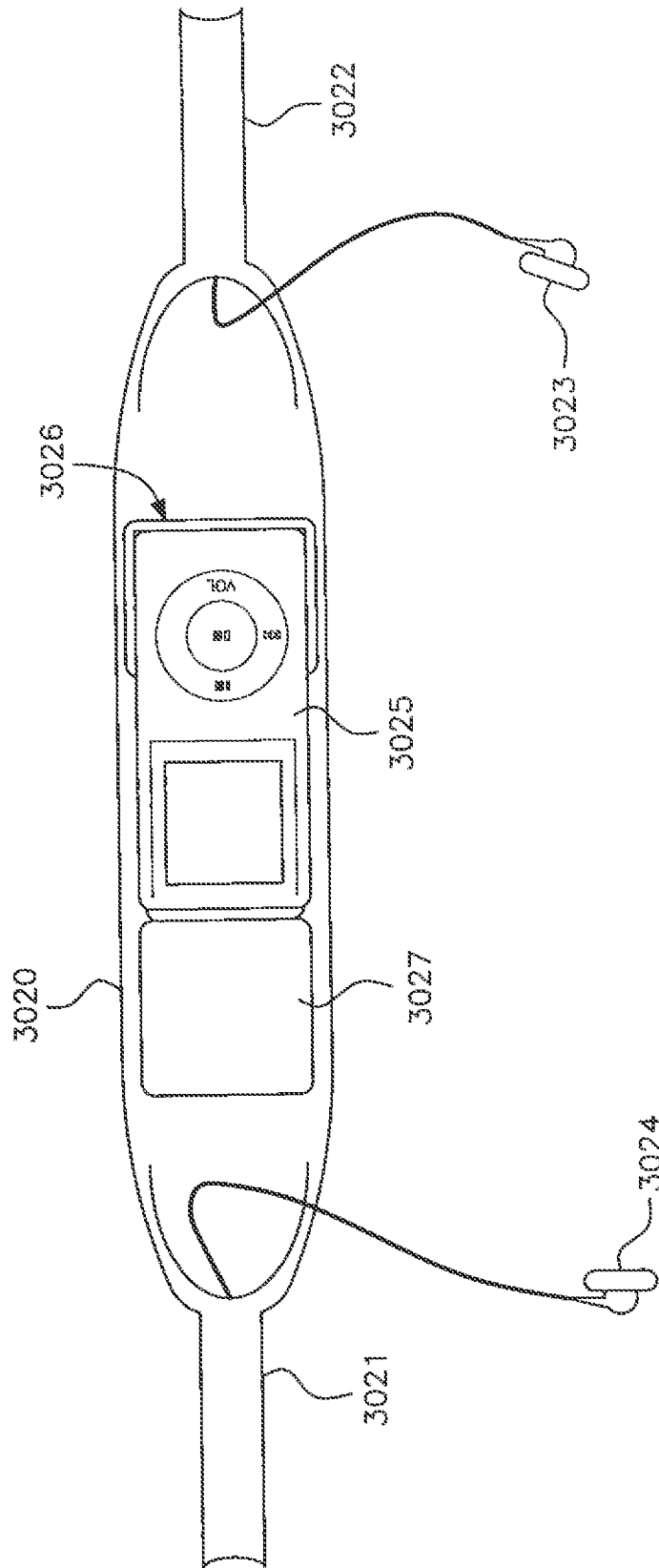

FIG. 65

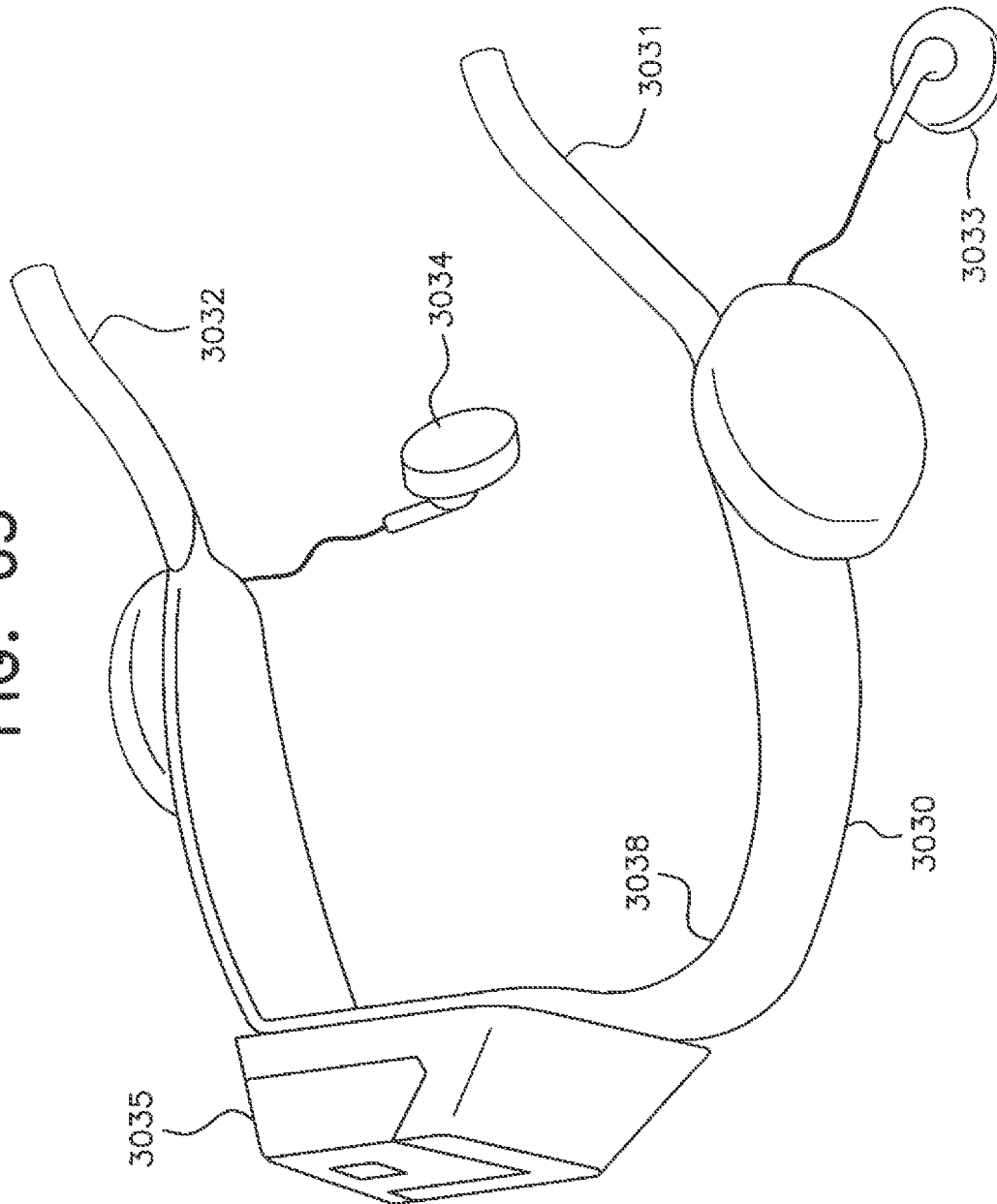

FIG. 66

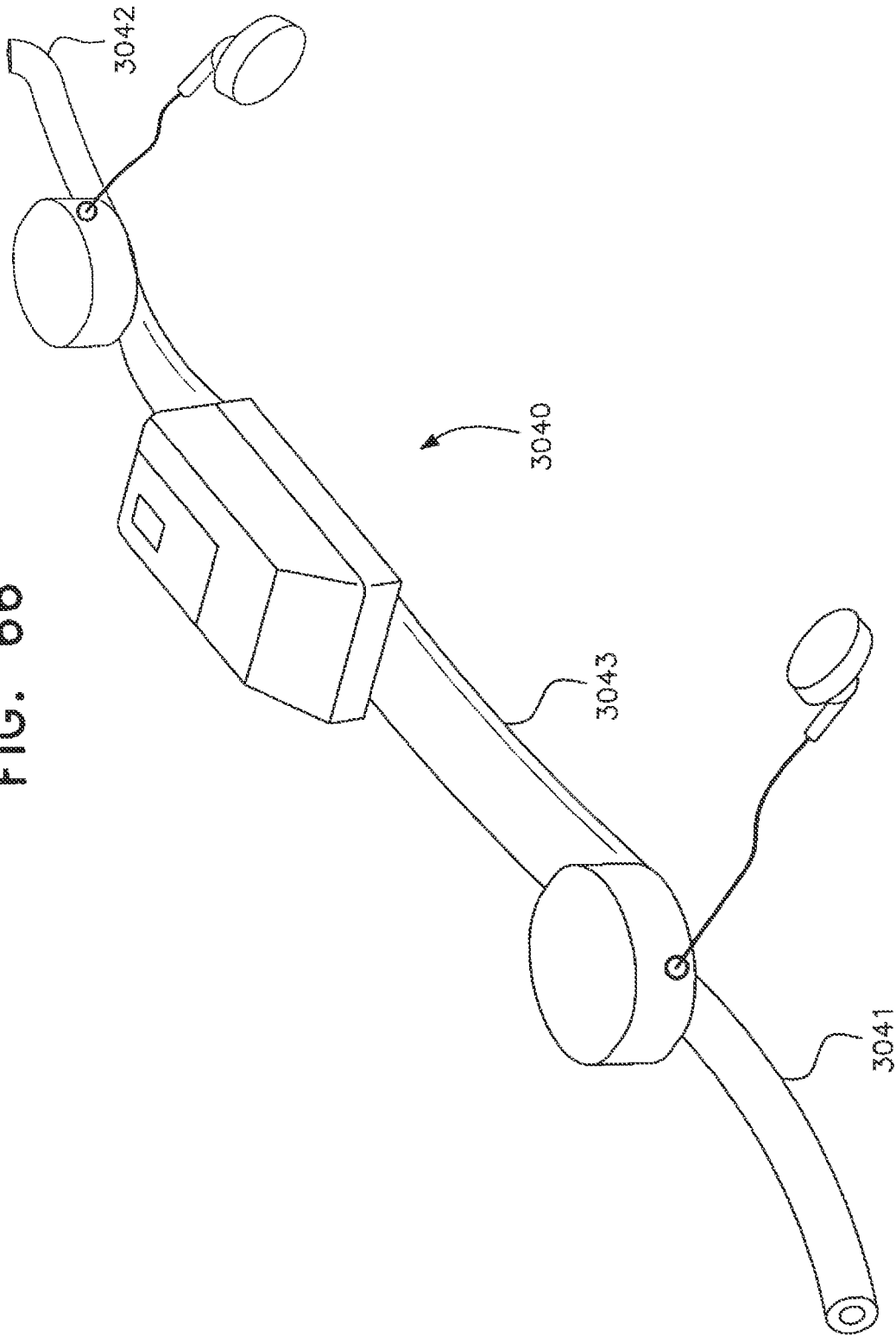

FIG. 67

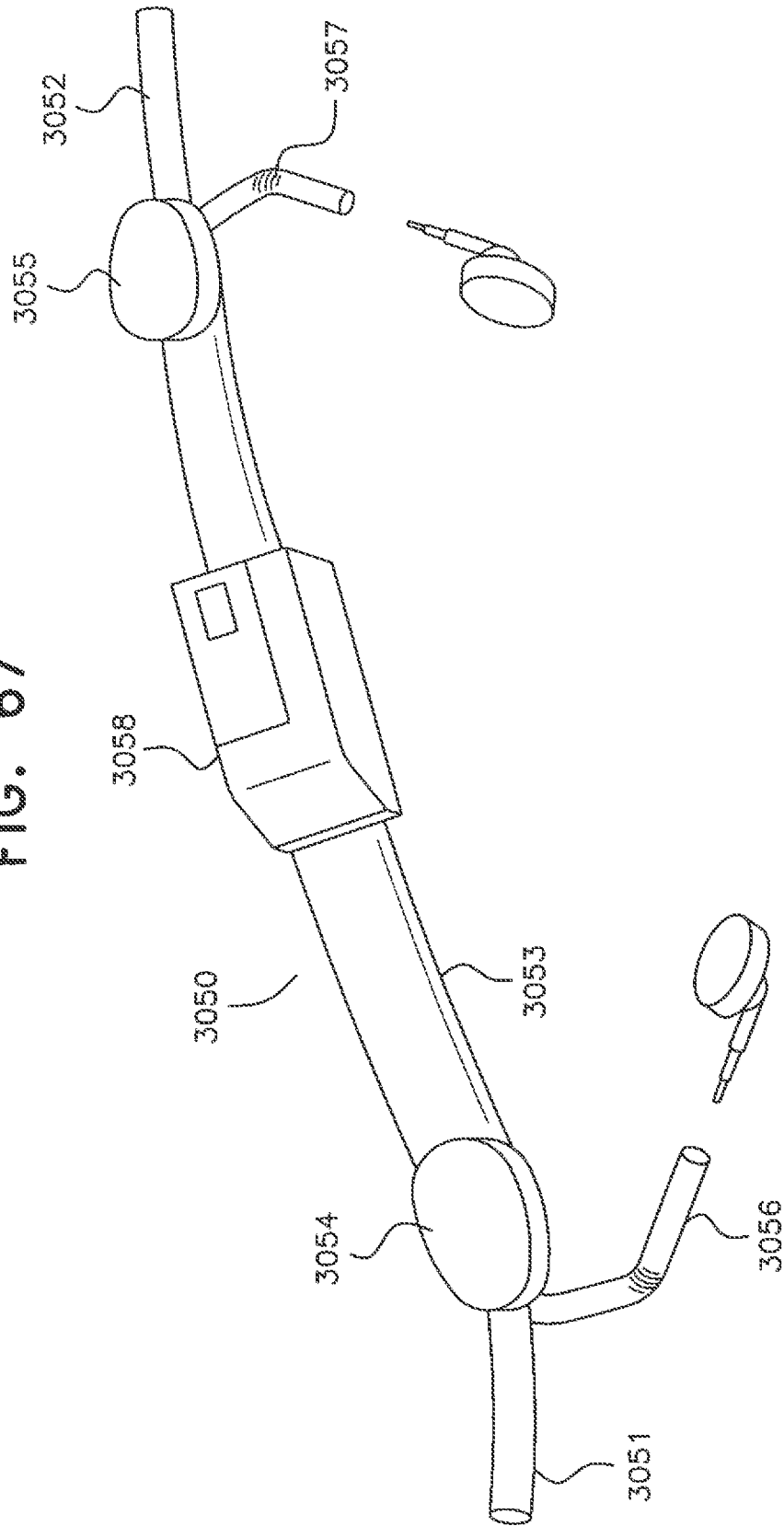

FIG. 68

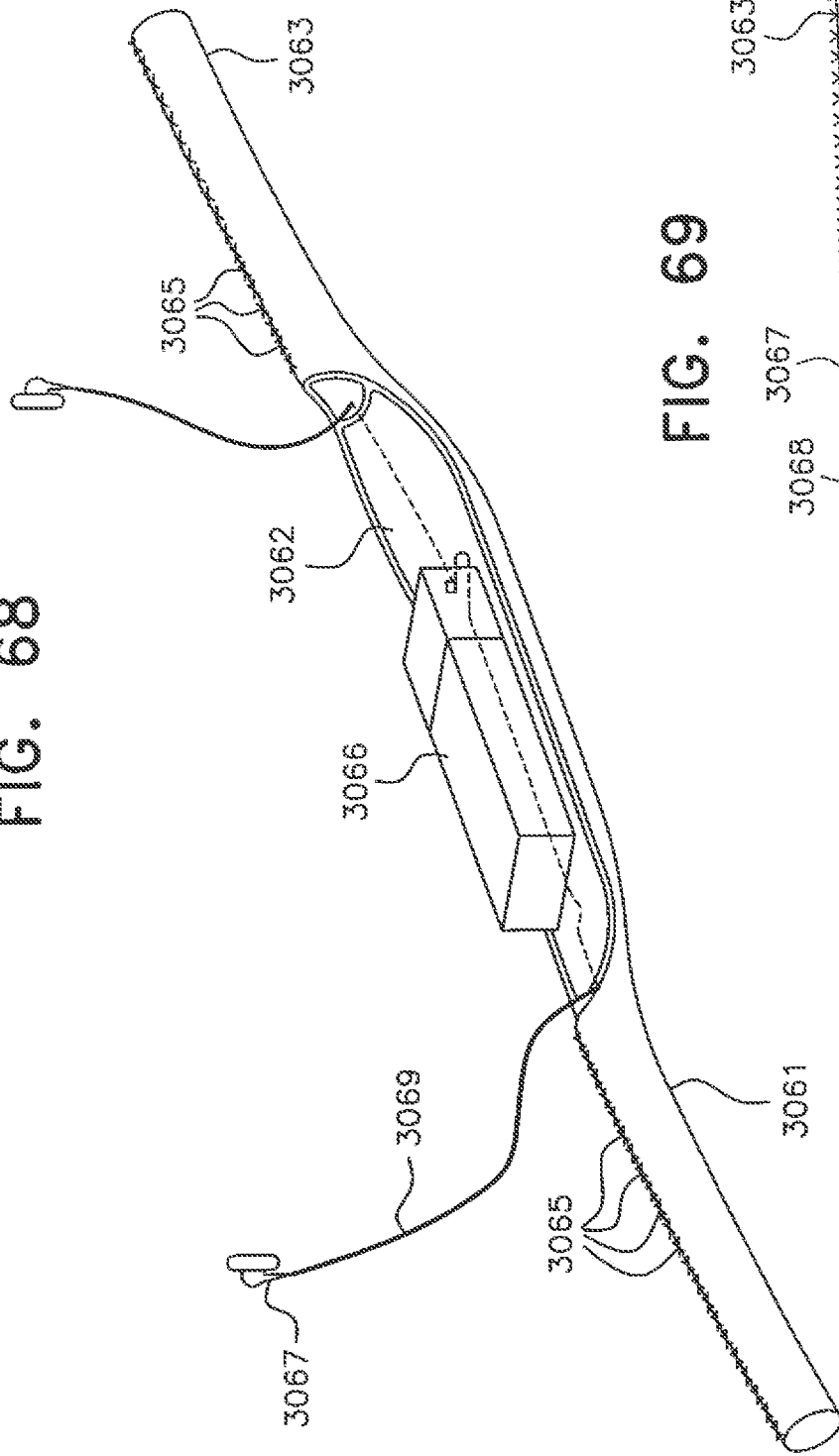

FIG. 69

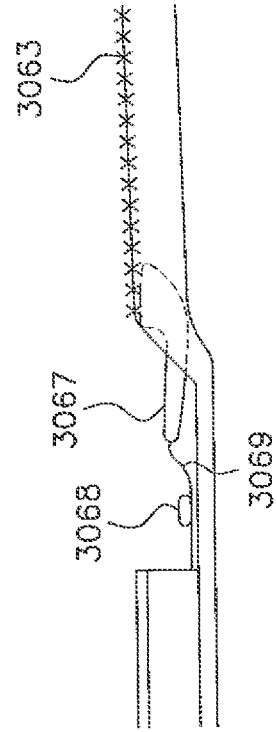

FIG. 70

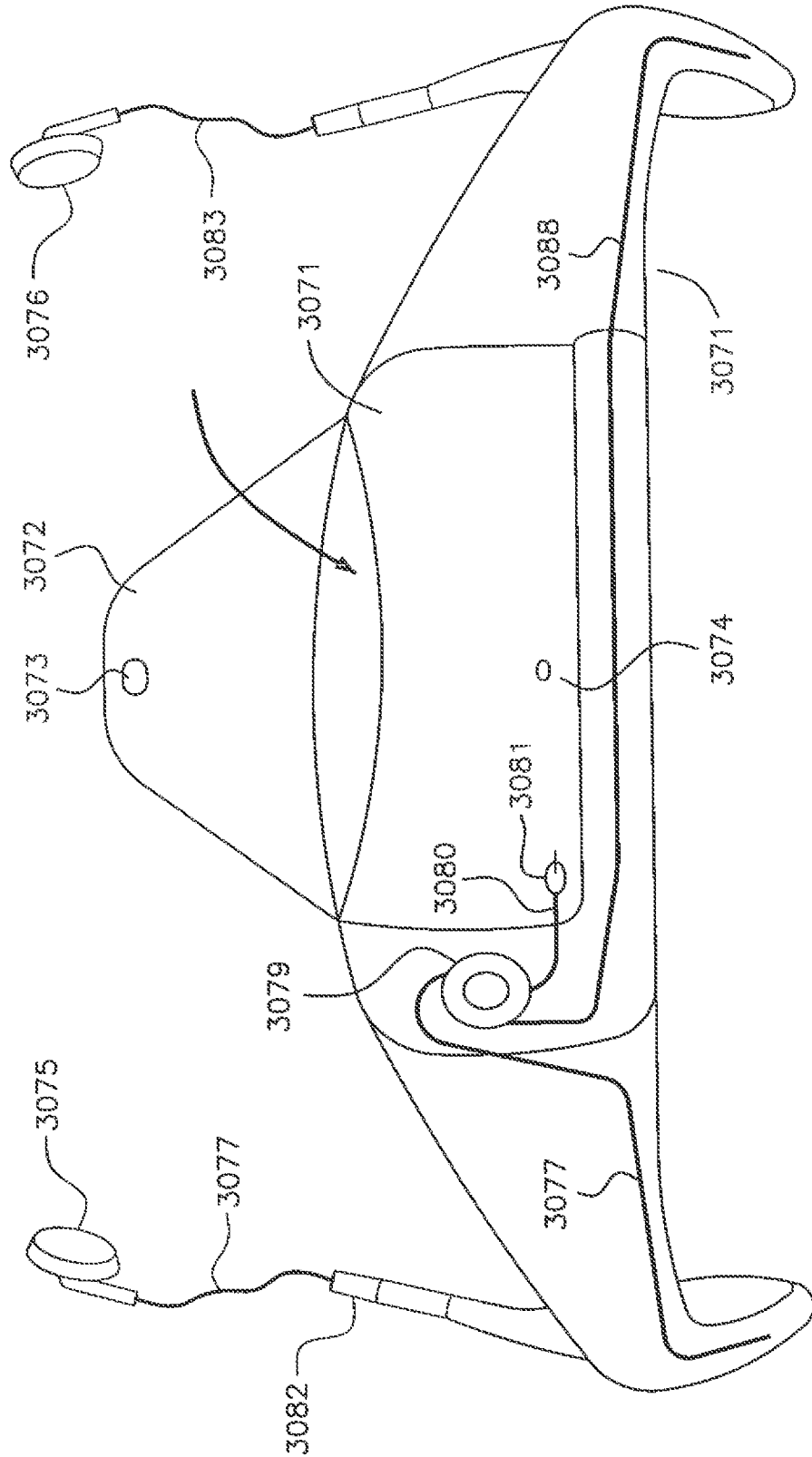

FIG. 71

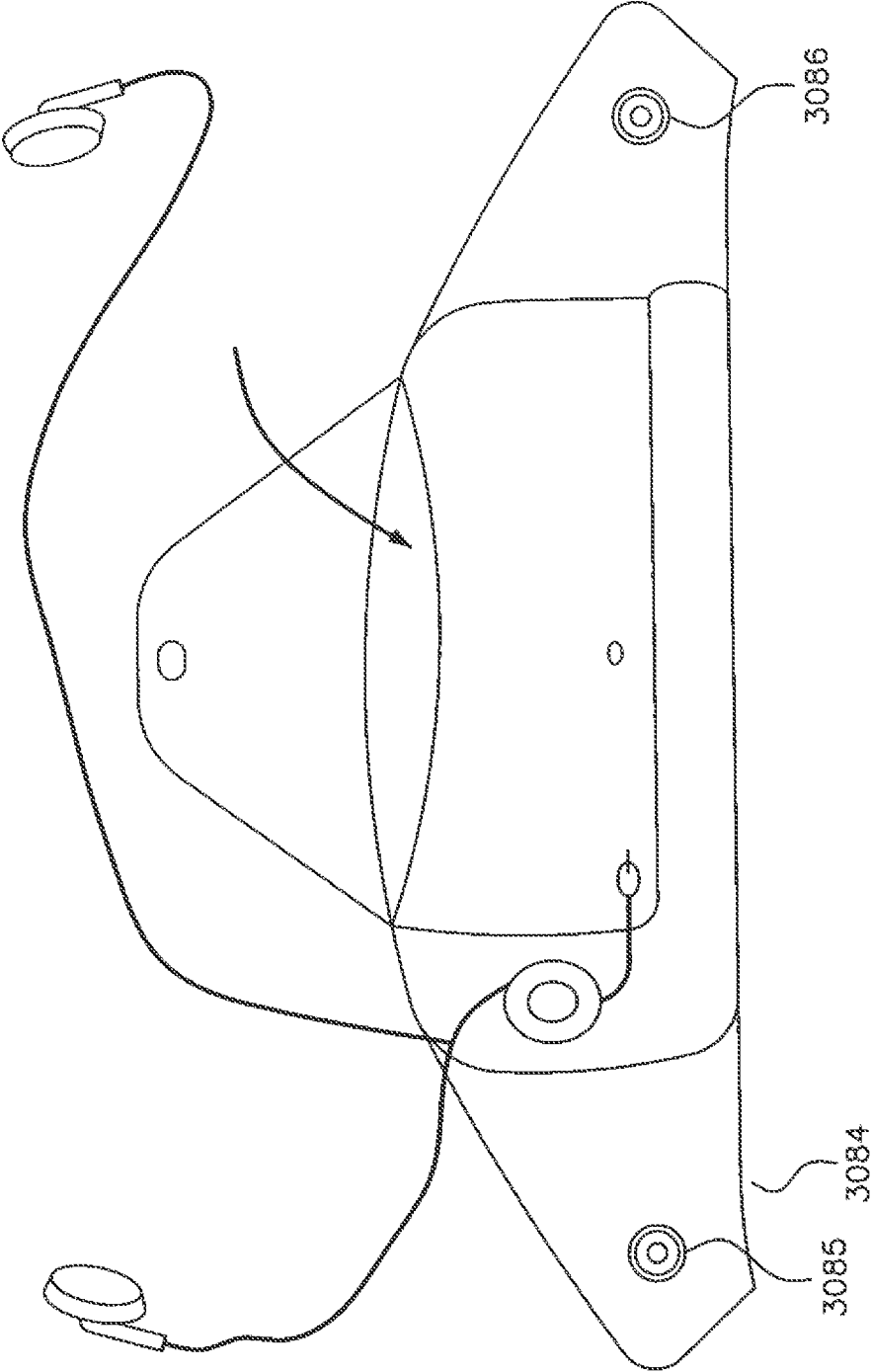

FIG. 72

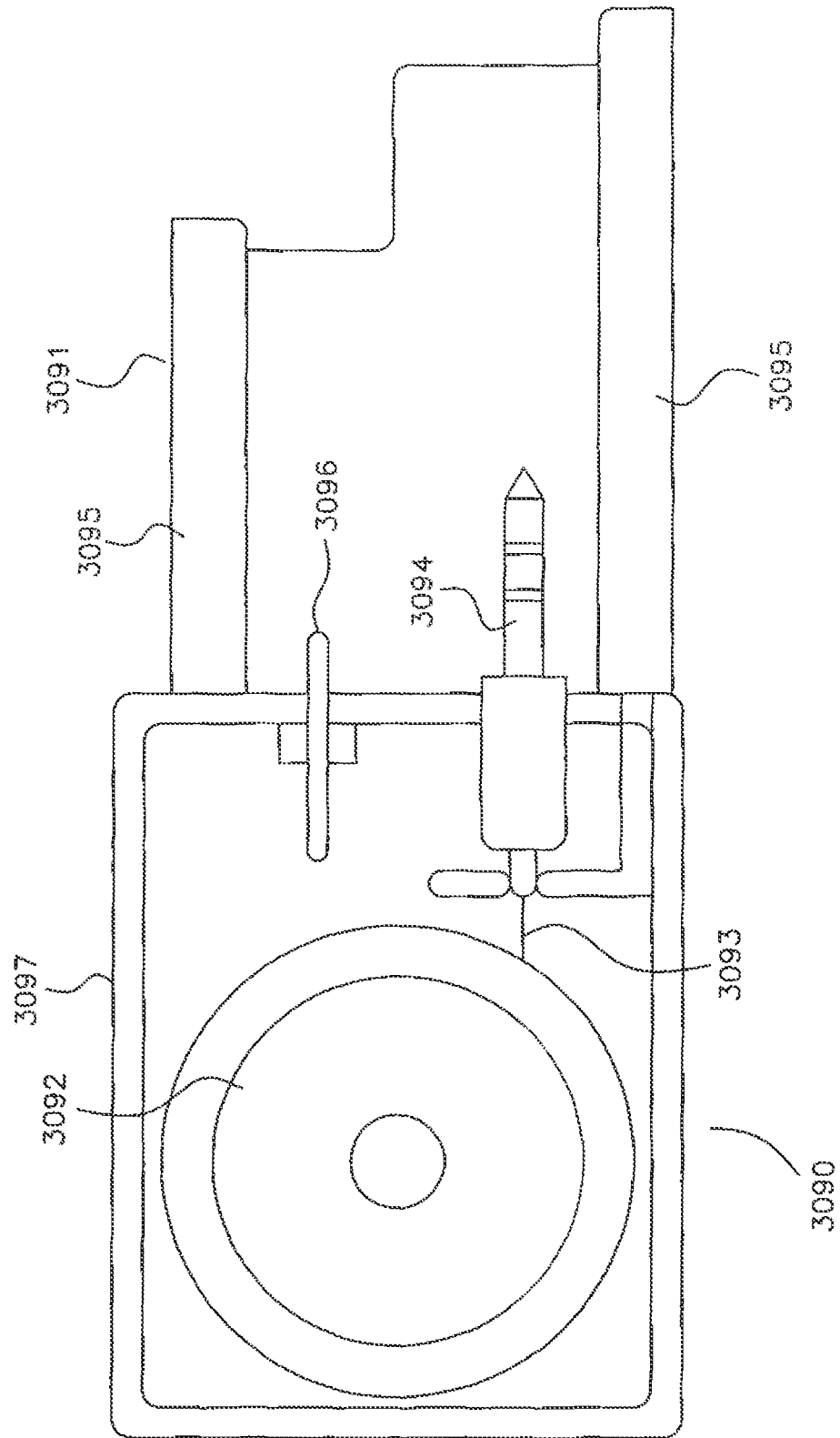

FIG. 73A

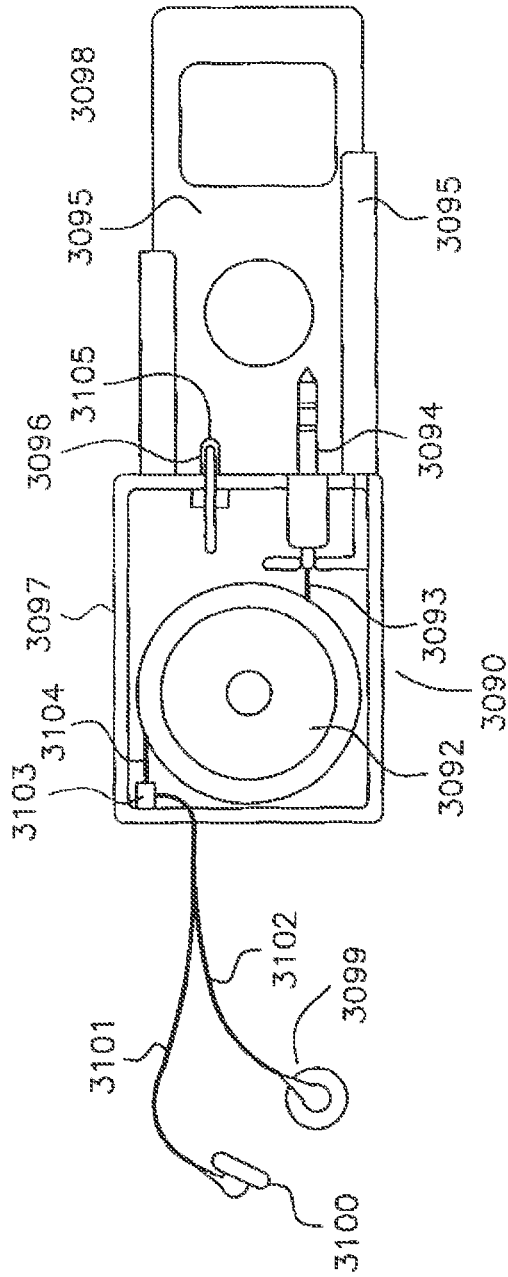

FIG. 73B

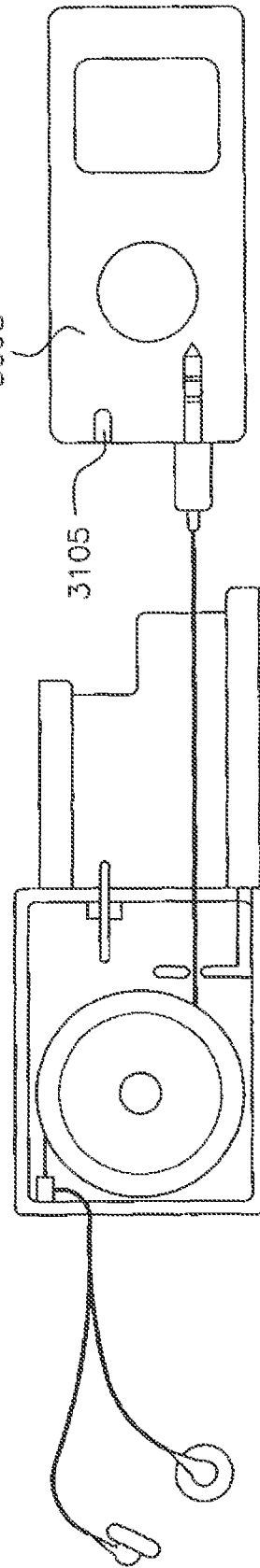

FIG. 74A

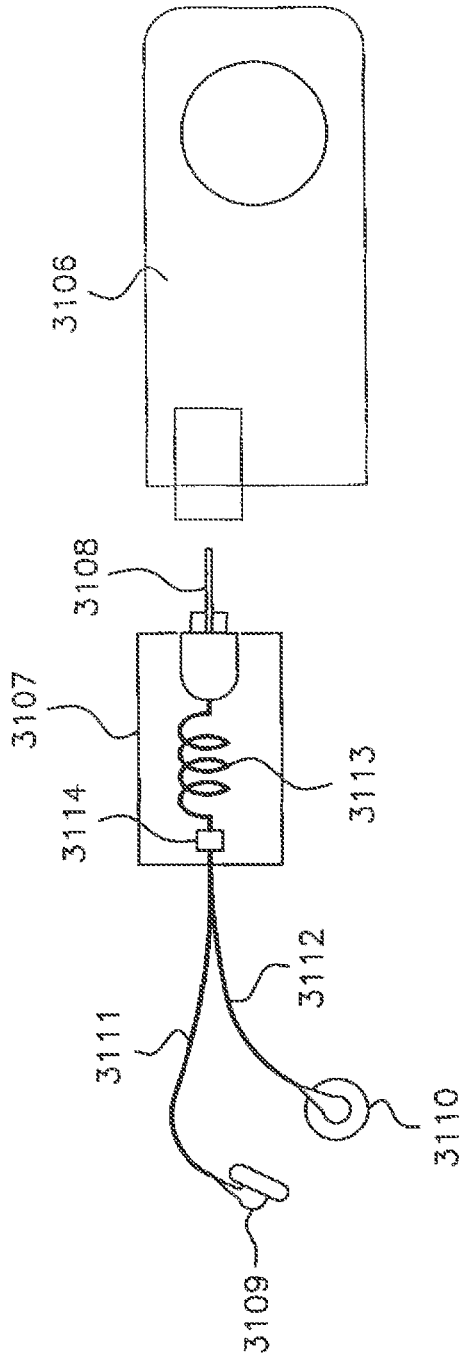

FIG. 74B

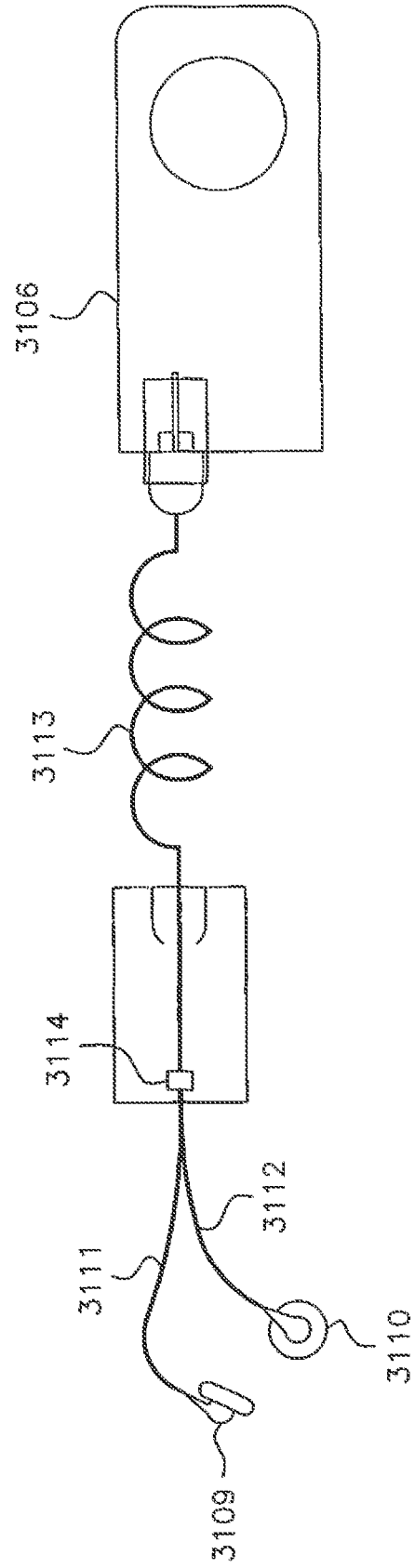

FIG. 75B2

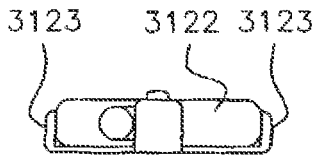

FIG. 75C

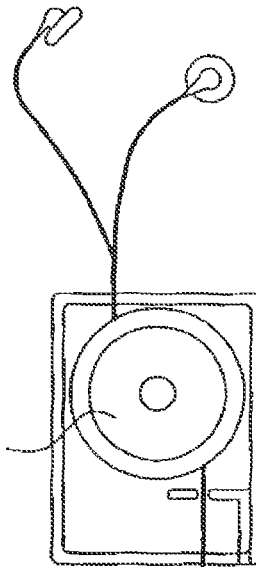

FIG. 75B

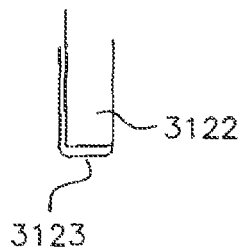

FIG. 75B1

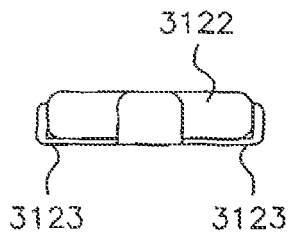

FIG. 75A

FIG. 75A1

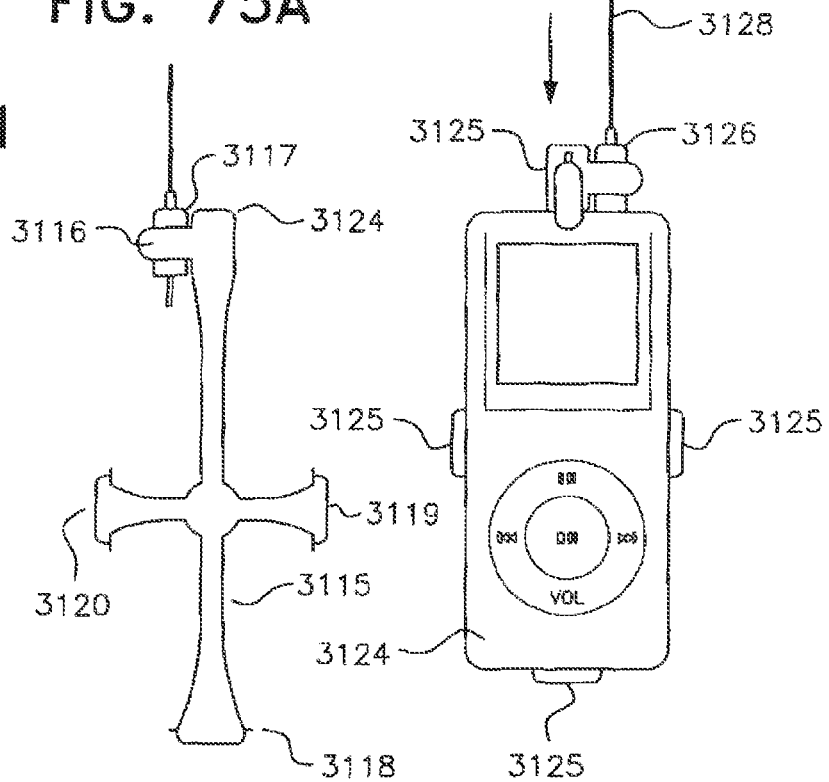
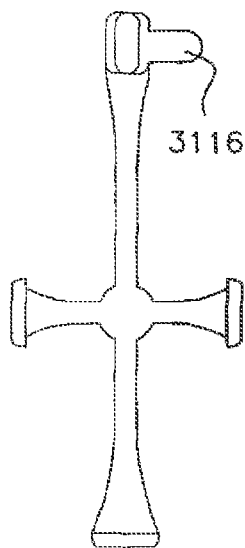

FIG. 75D2

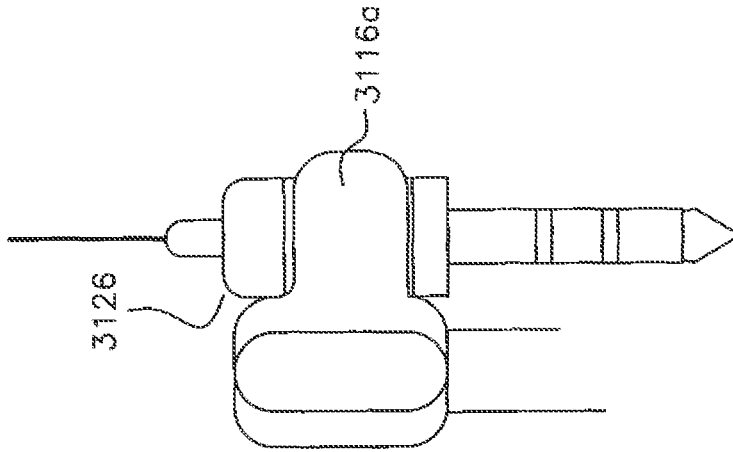

FIG. 75D1

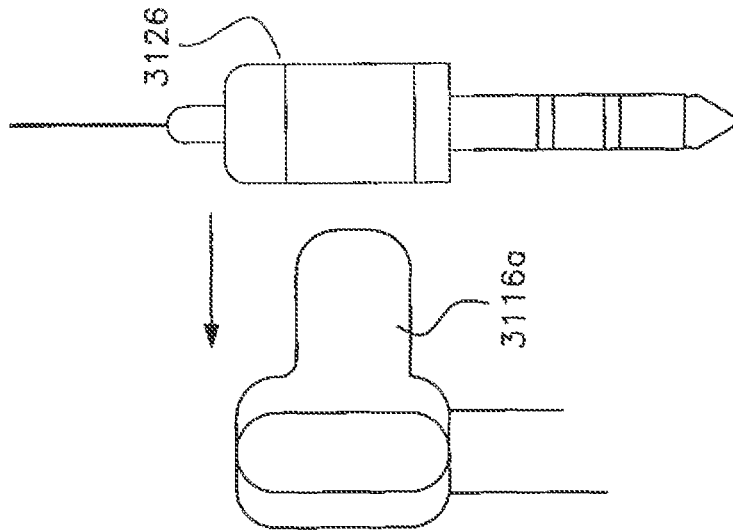

FIG. 75D3

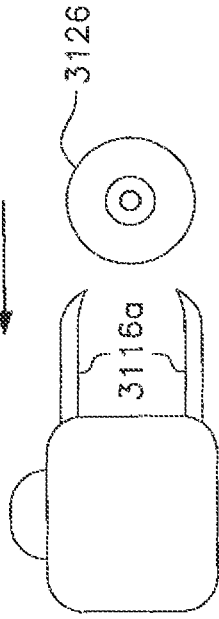

FIG. 75D4

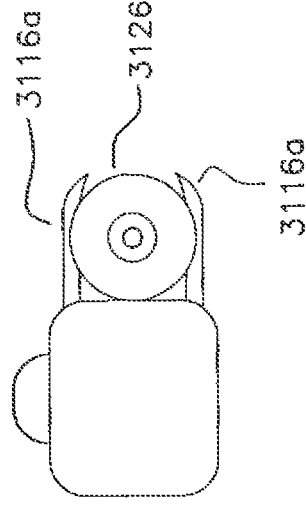

FIG. 76

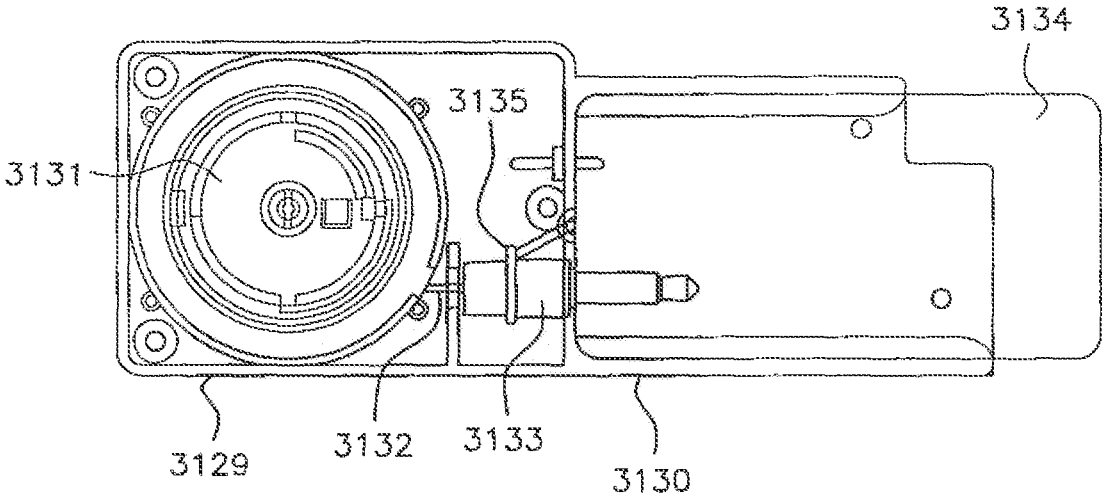

FIG. 76A

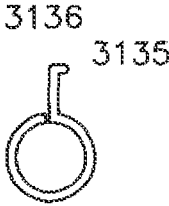

FIG. 77

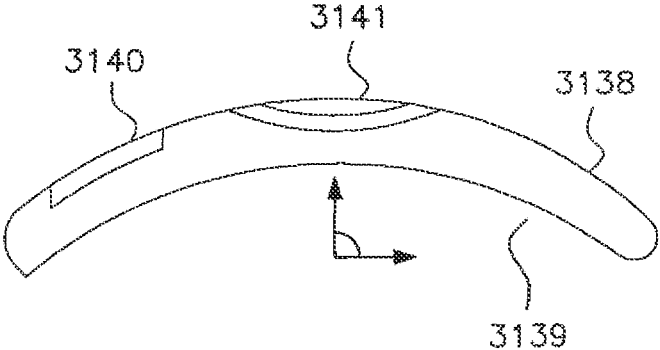
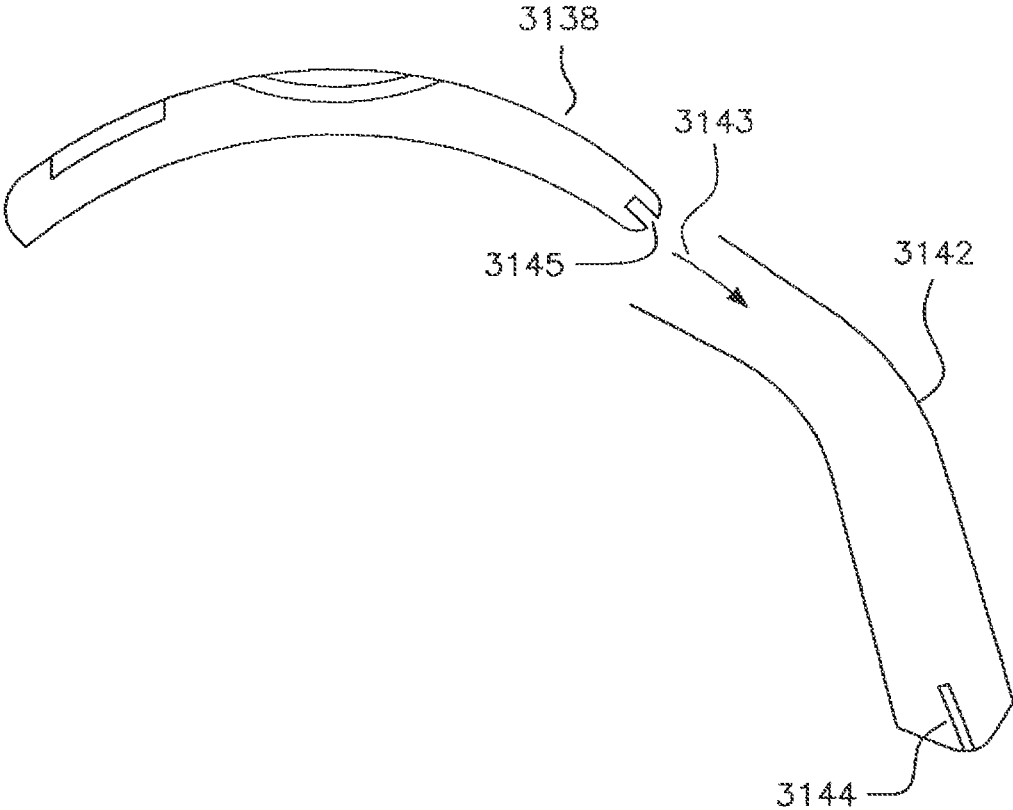

FIG. 78



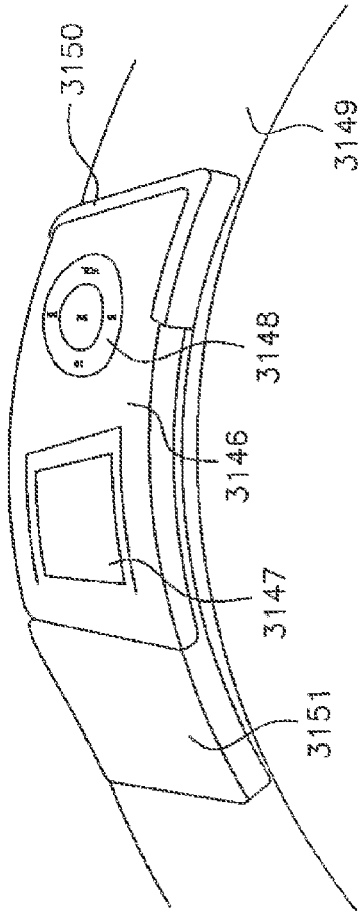

FIG. 79A

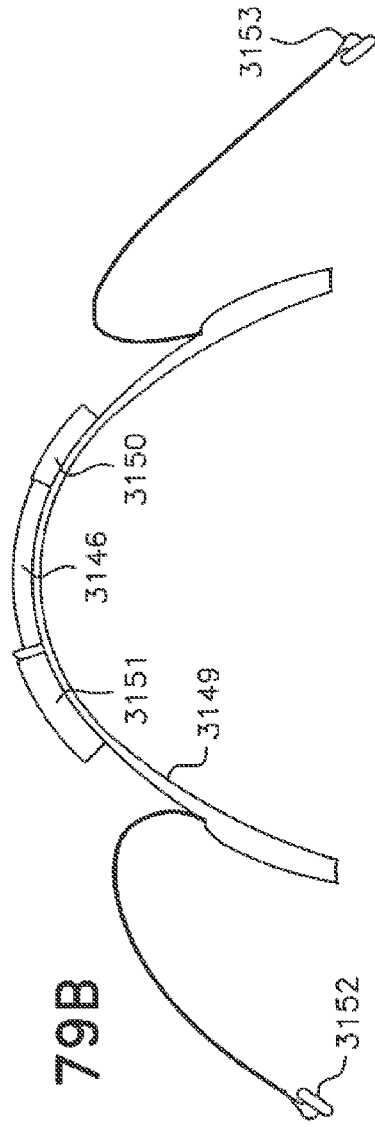

FIG. 79B

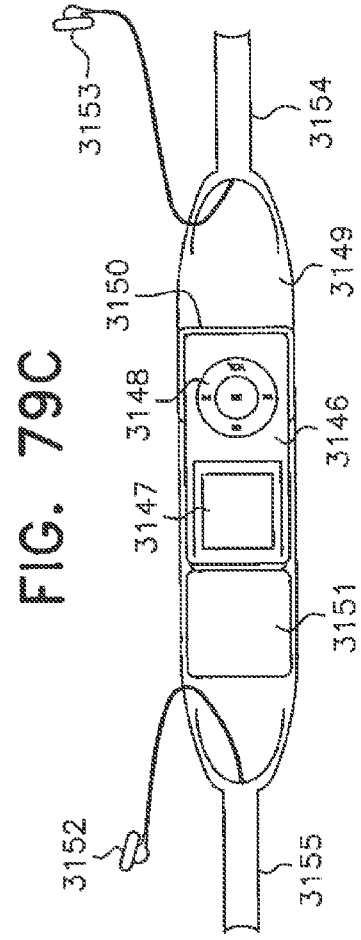

FIG. 79C

FIG. 80A

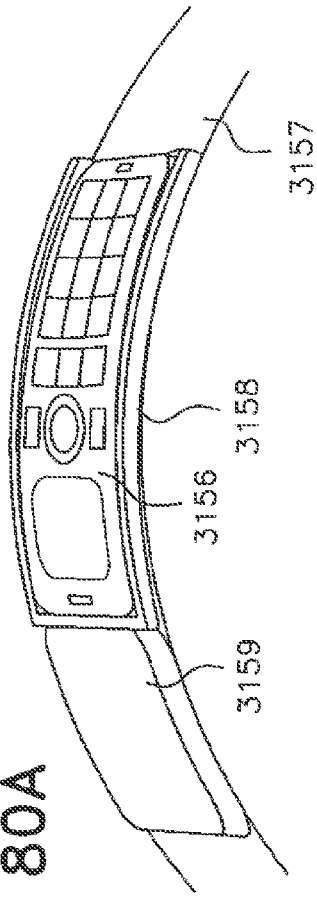

FIG. 80B

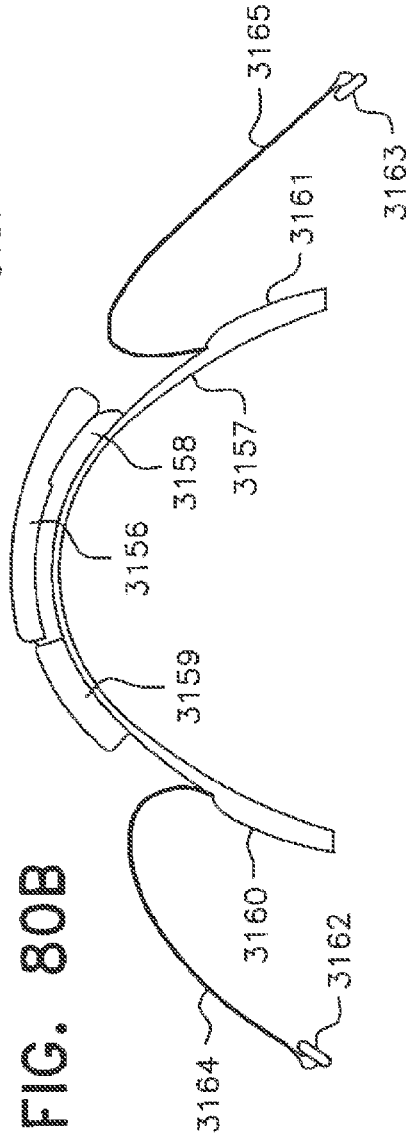

FIG. 80C

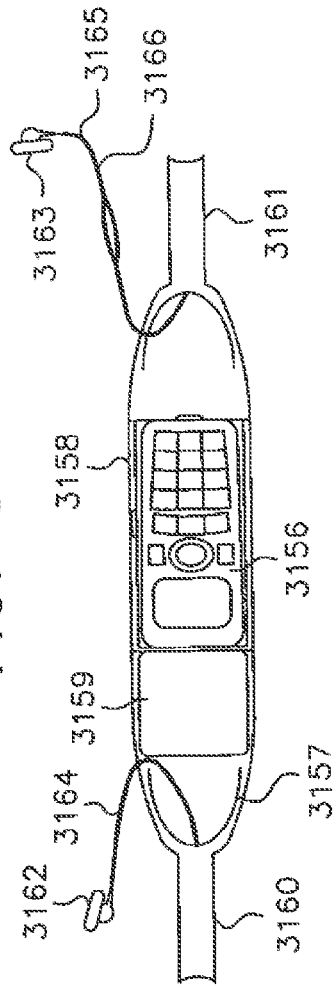

FIG. 81E



FIG. 81F

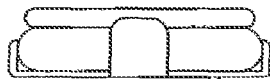

FIG. 81D



FIG. 81C

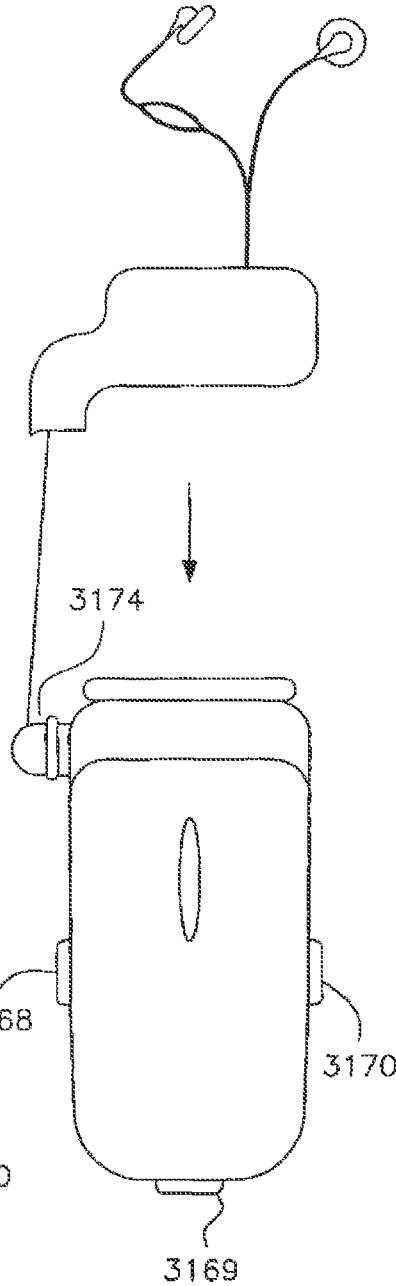

FIG. 81A

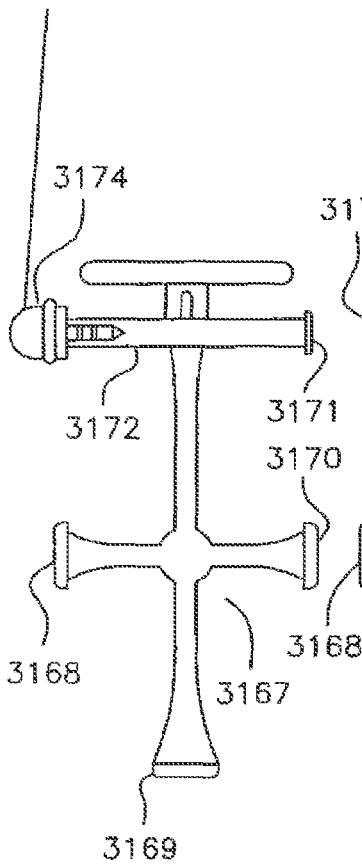

FIG. 81B

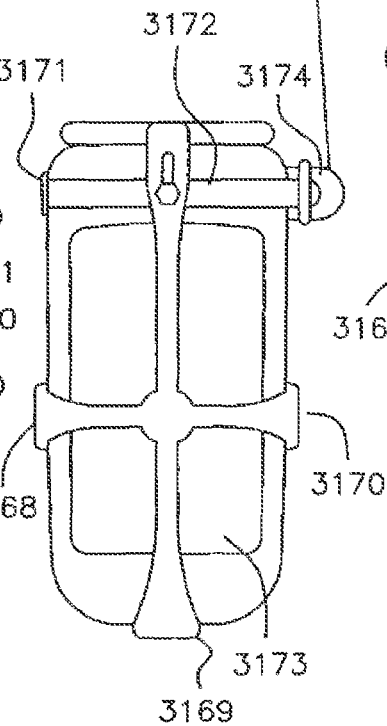

FIG. 82

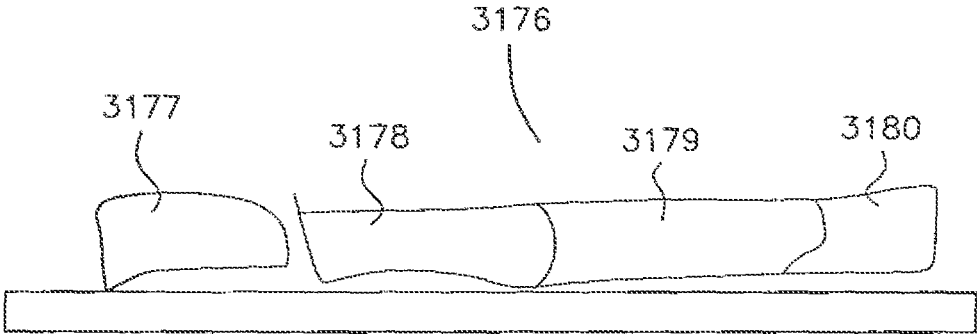

FIG. 83

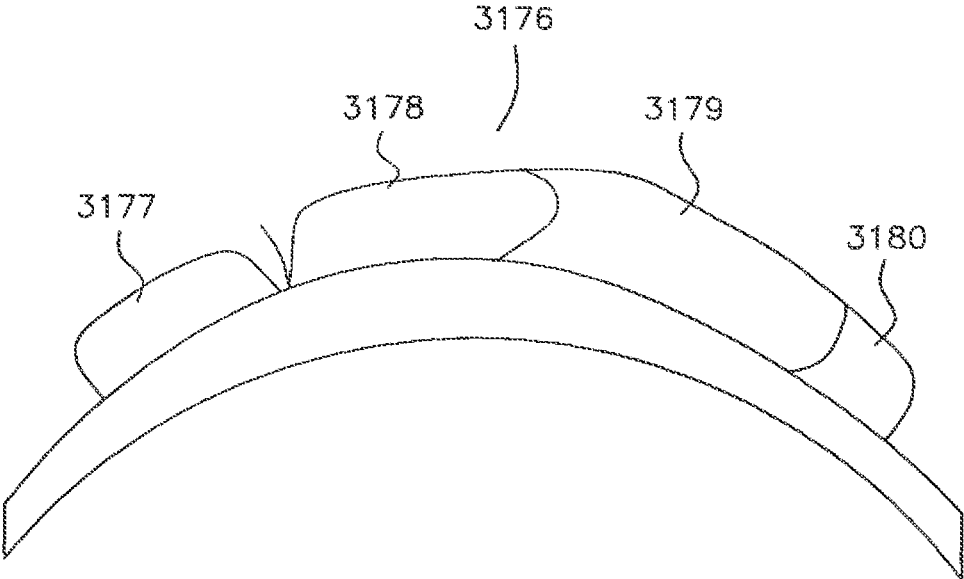

FIG. 84A

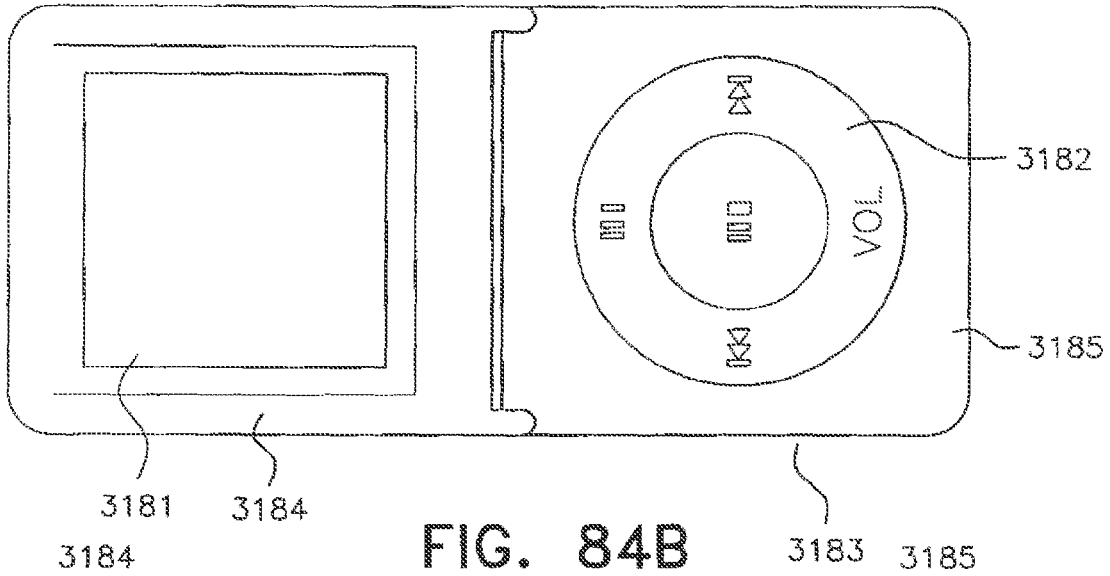

FIG. 84B

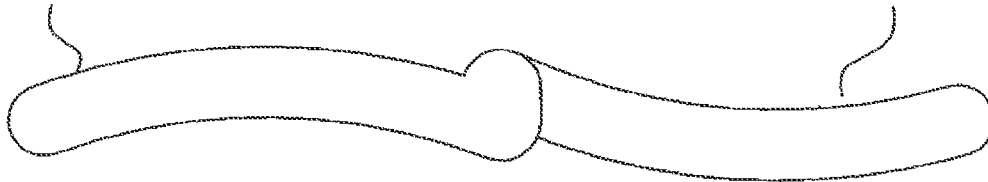

FIG. 84C

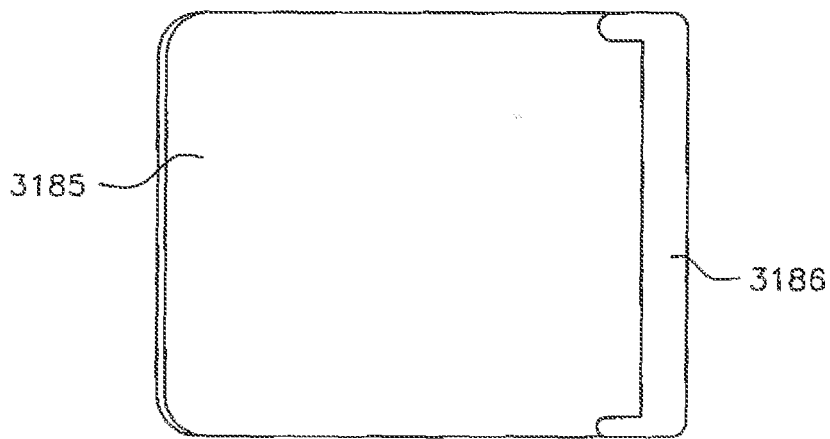

FIG. 84D

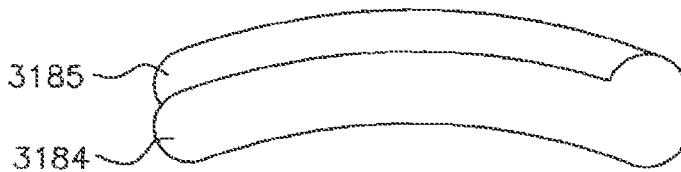
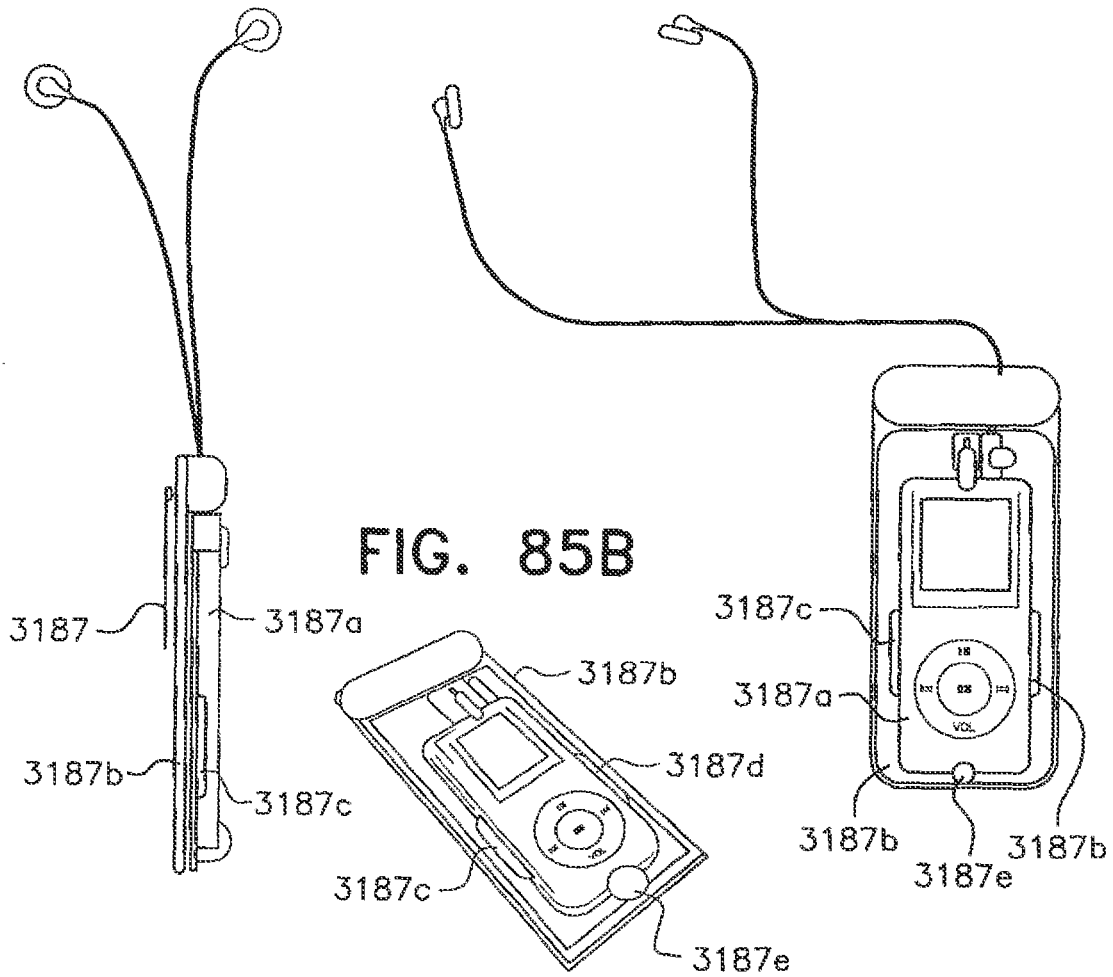

FIG. 85A

FIG. 85C



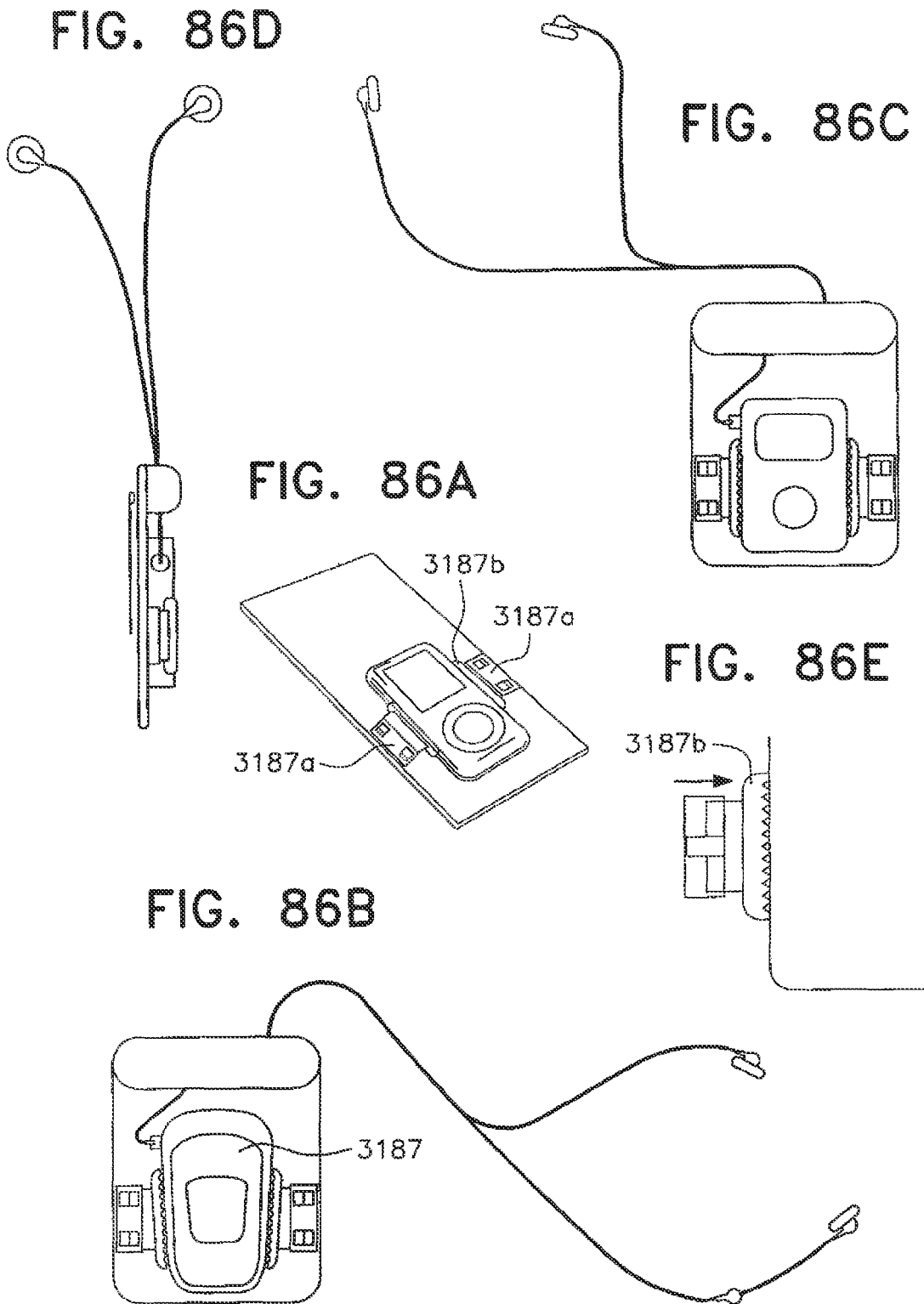

FIG. 87D

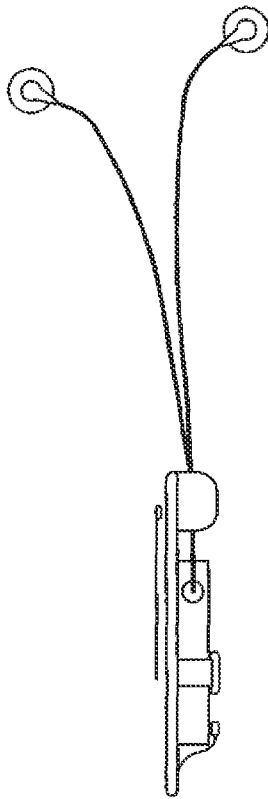

FIG. 87C

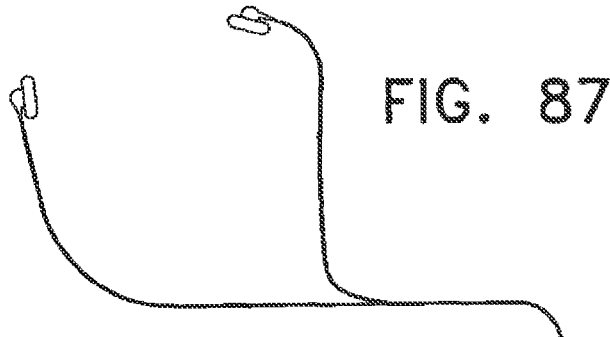

FIG. 87A

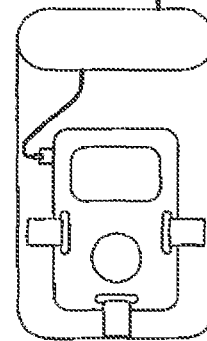
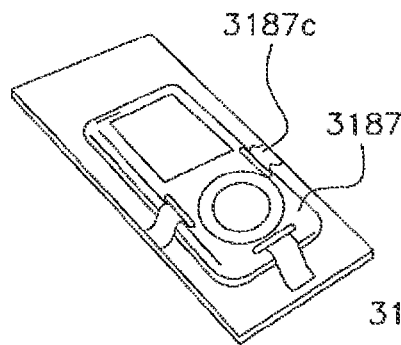

FIG. 87E



FIG. 87F

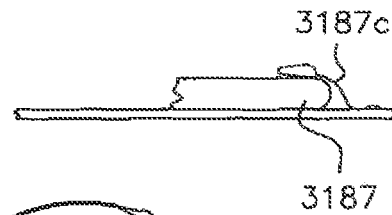
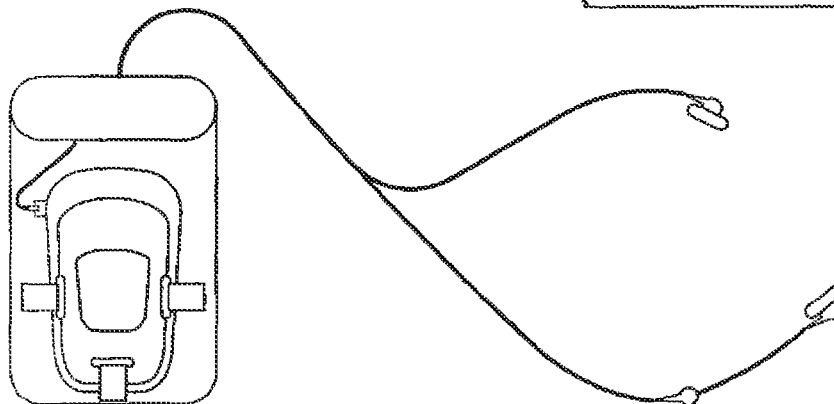

FIG. 87B



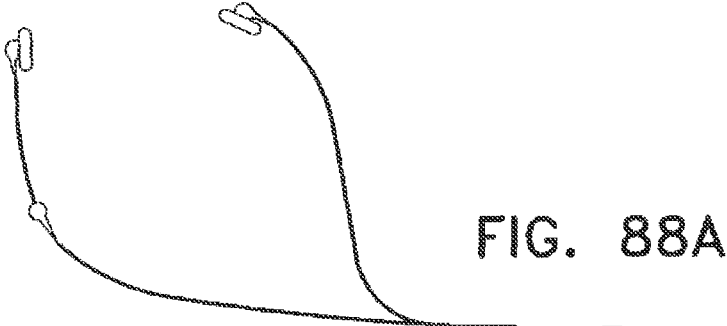

FIG. 88B

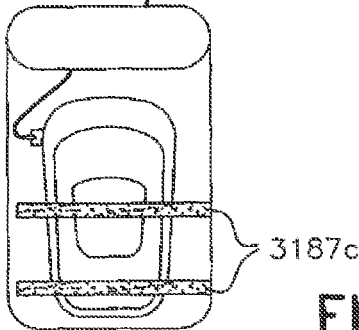
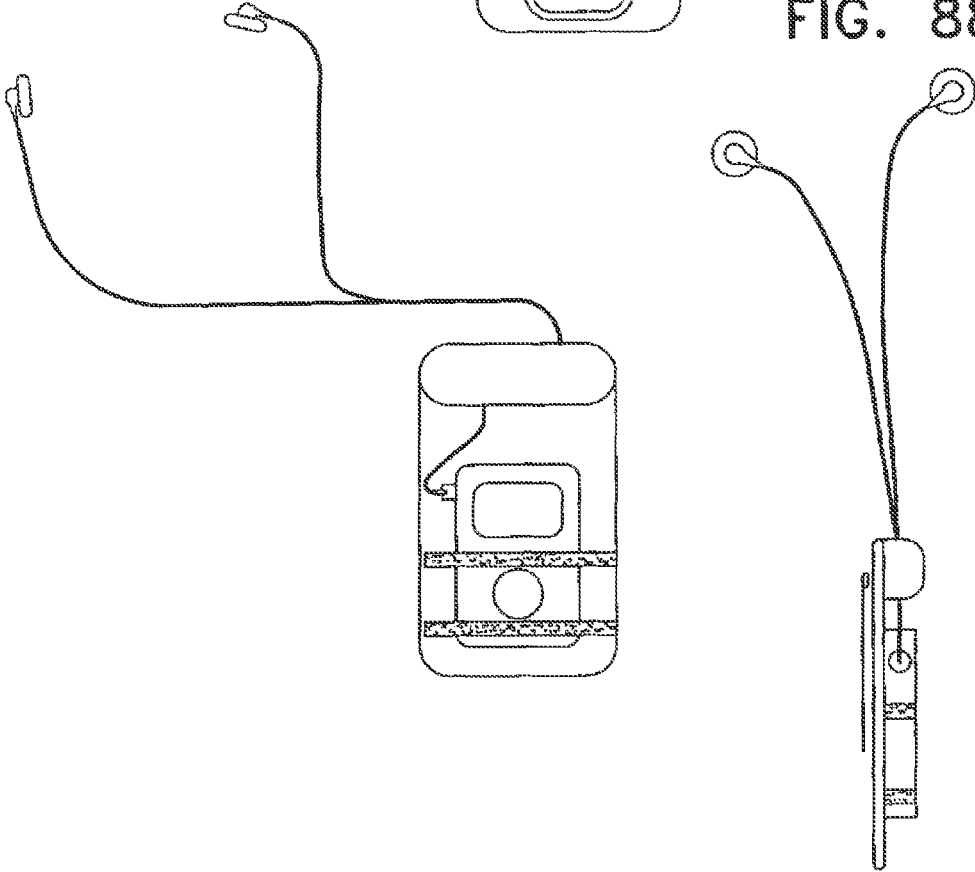

FIG. 88C



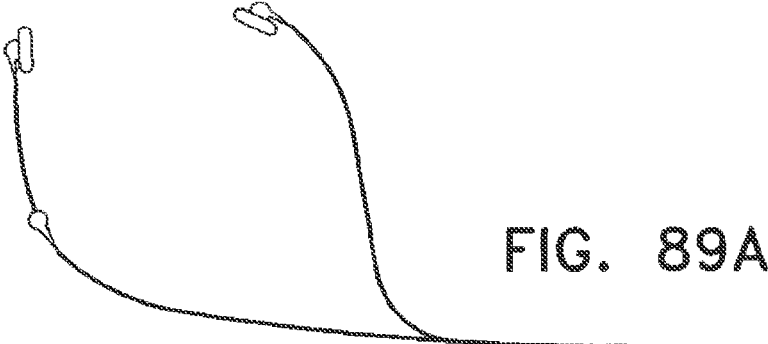

FIG. 89B

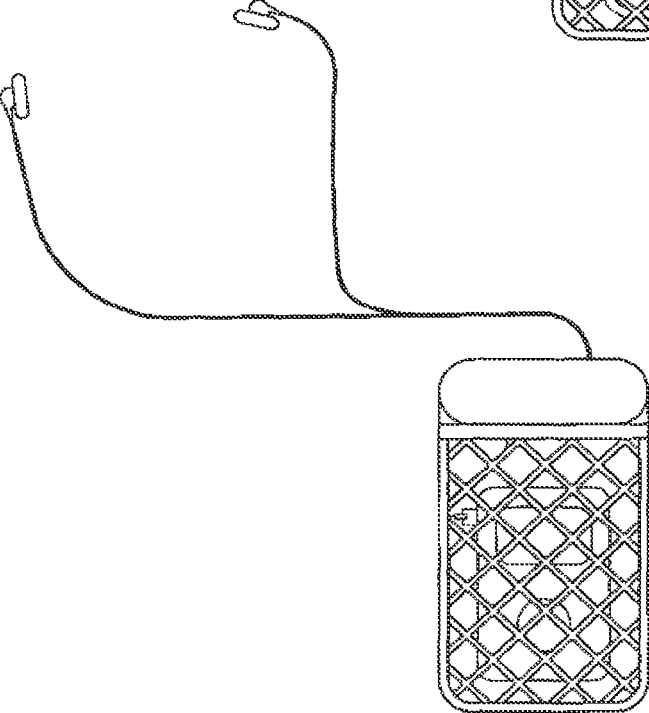

FIG. 89A

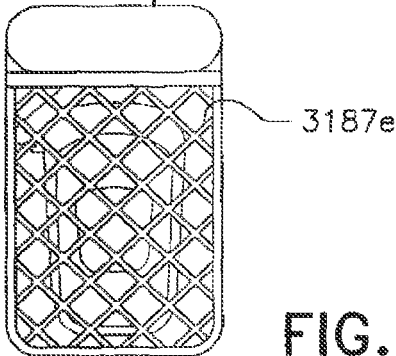

FIG. 89C

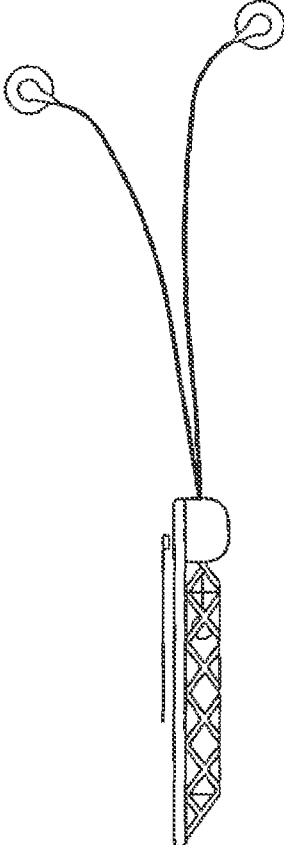

FIG. 90

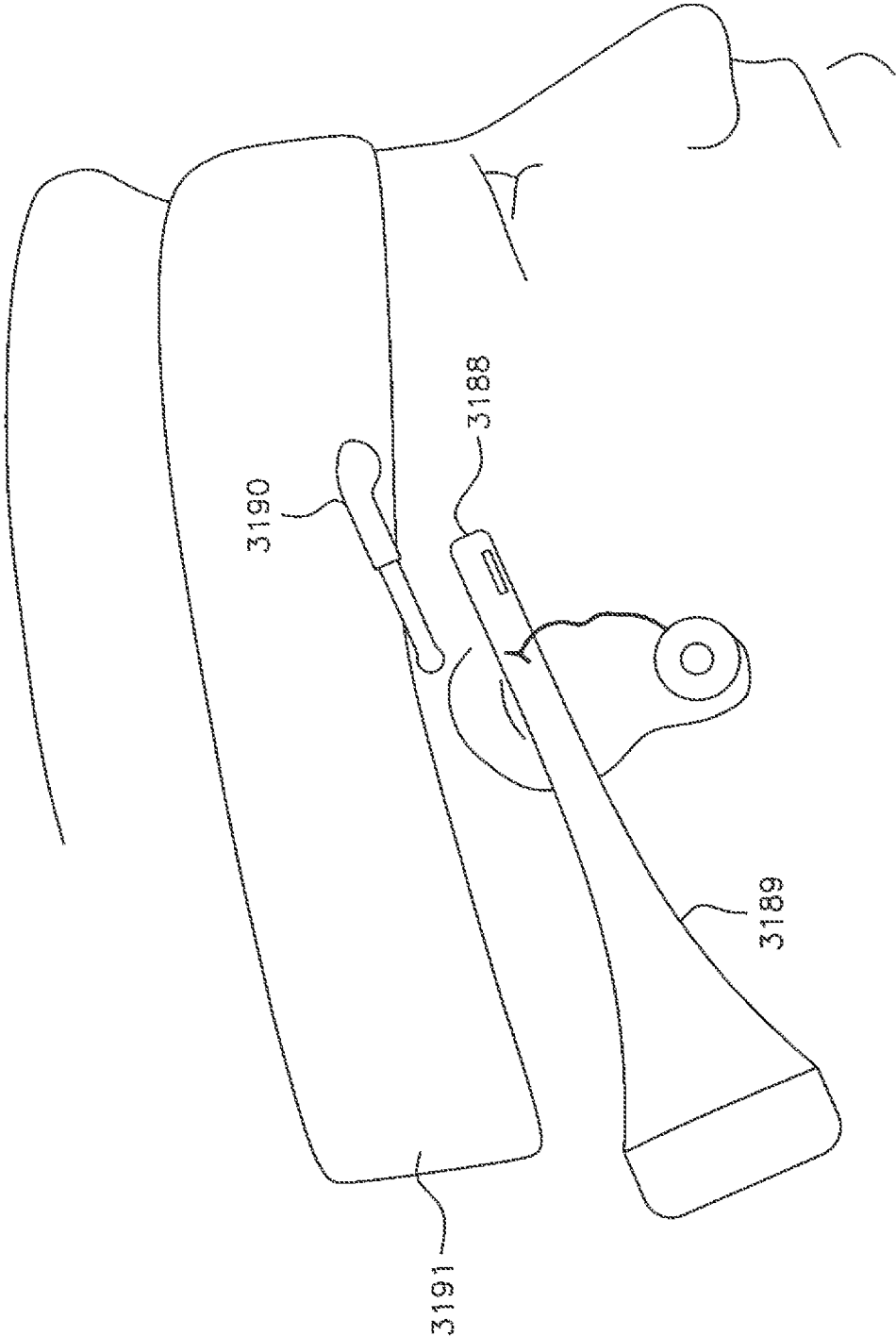

FIG. 91

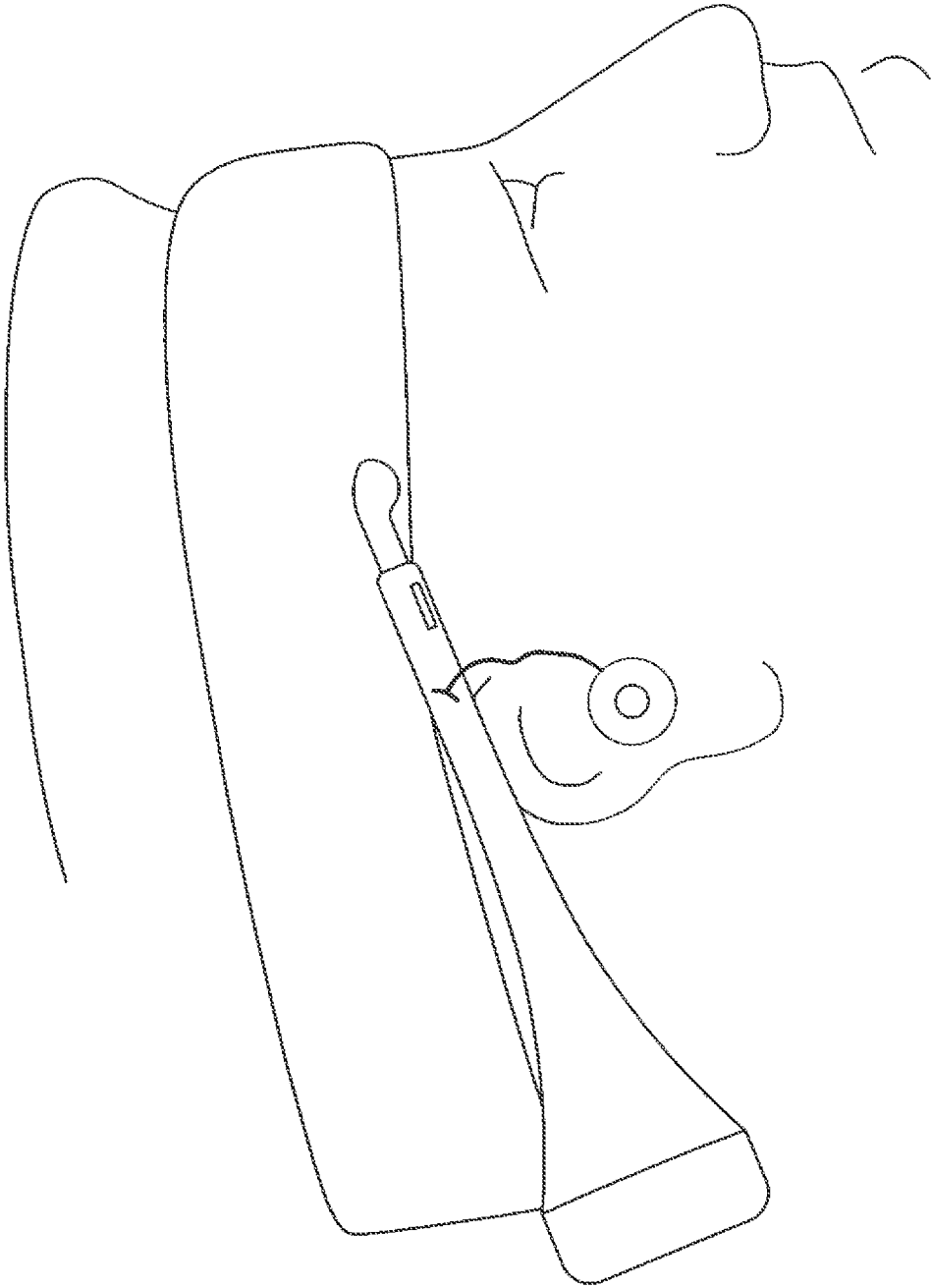

FIG. 91A

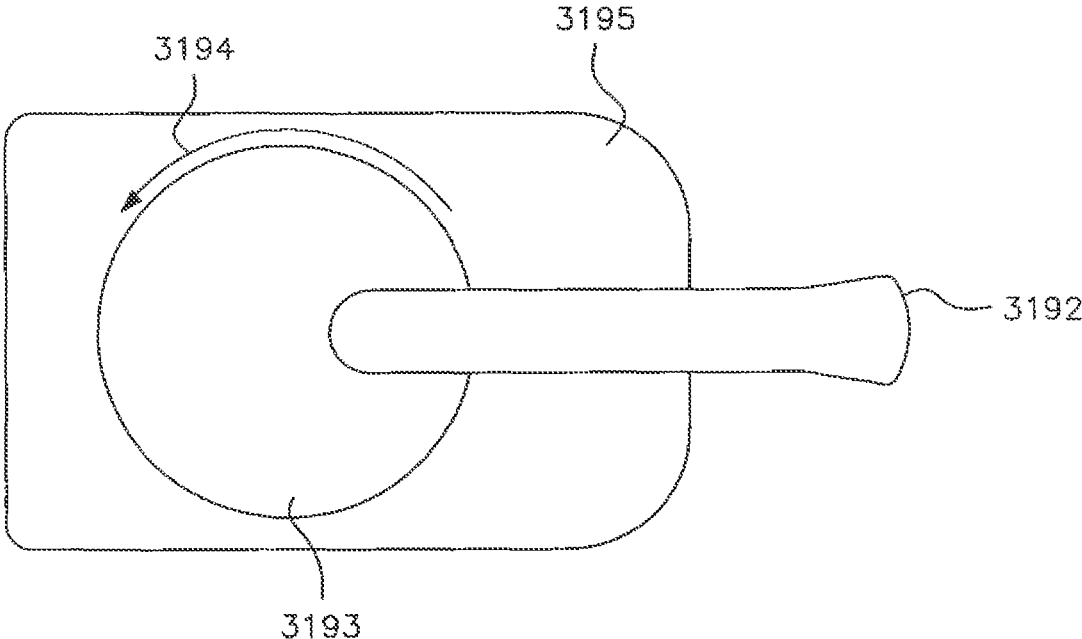

FIG. 91B

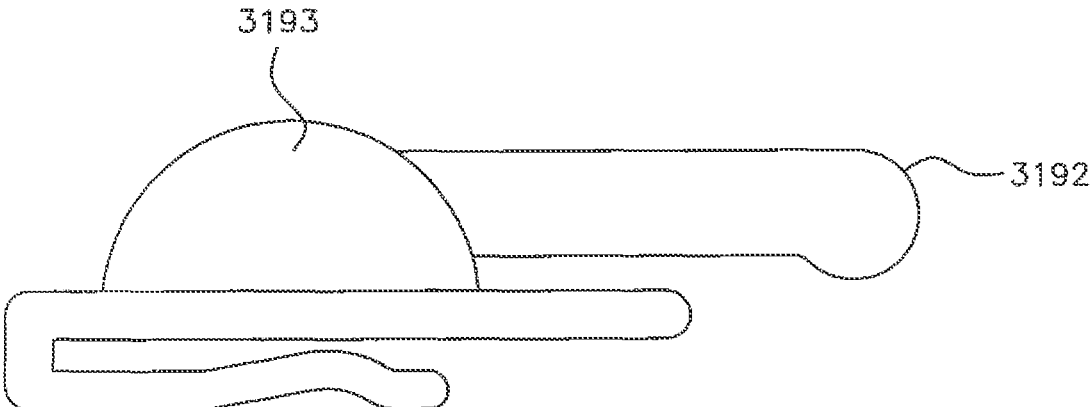

FIG. 92A

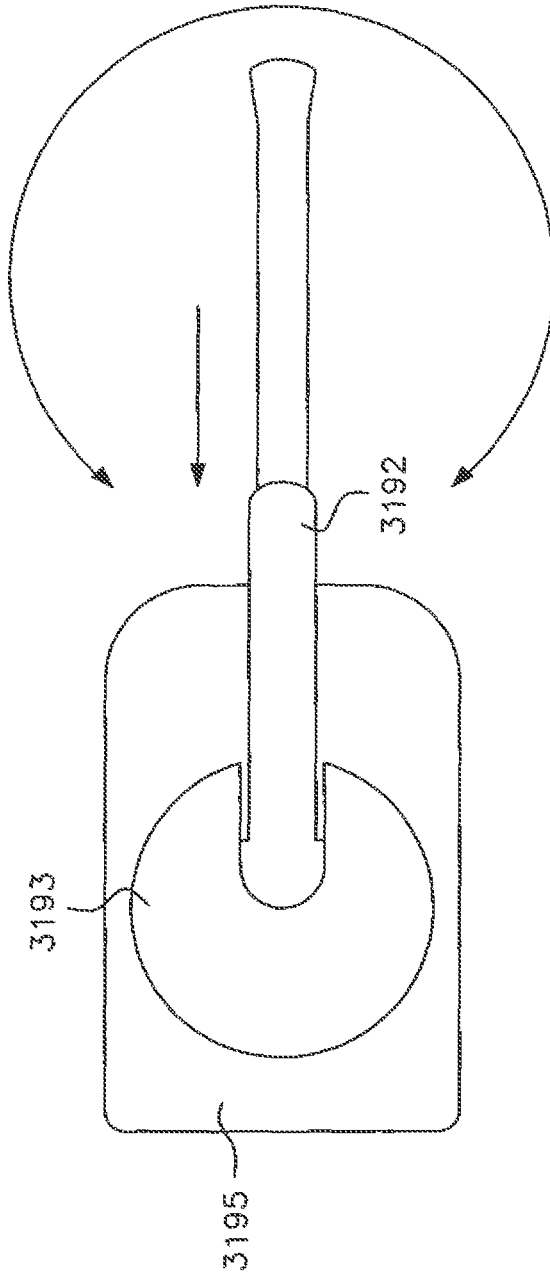

FIG. 92B

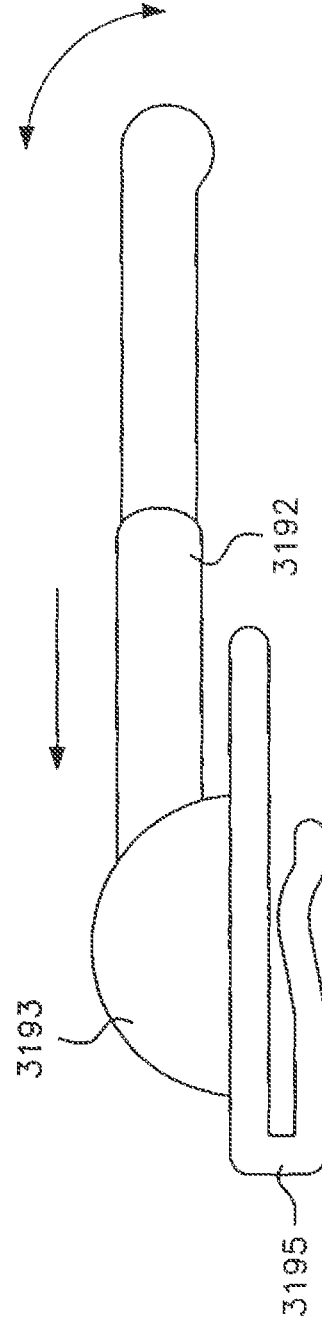

FIG. 93

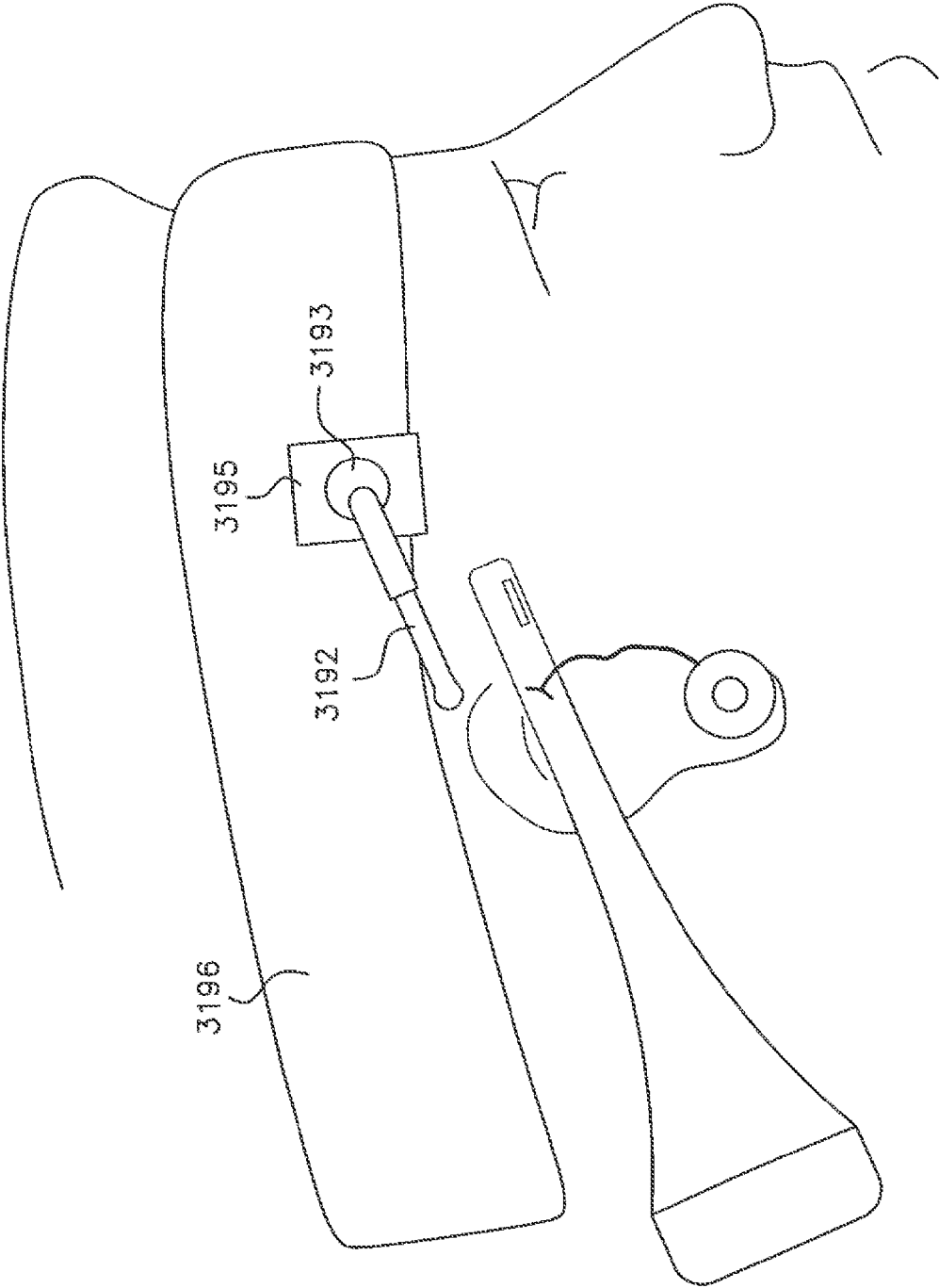

FIG. 94

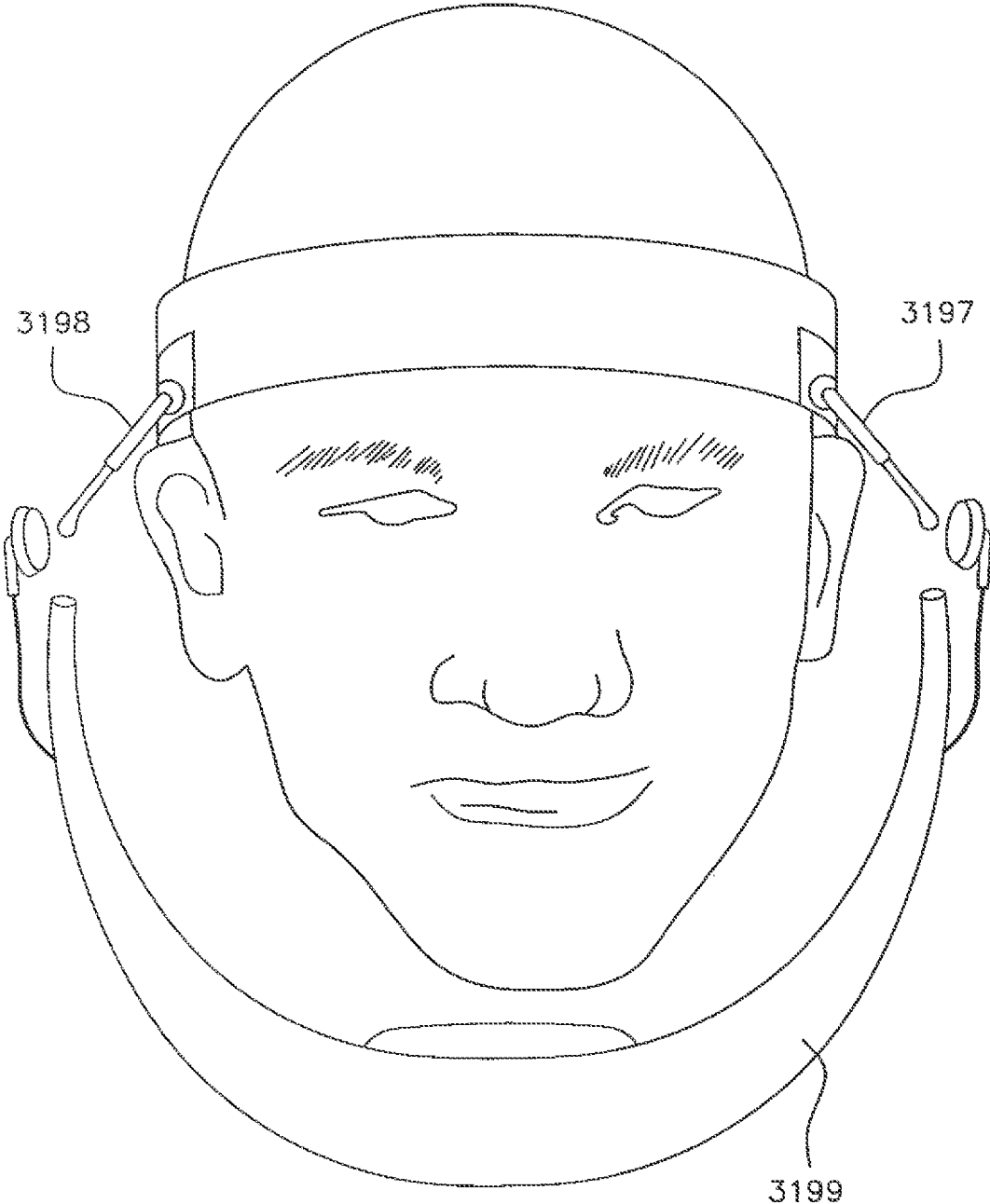

FIG. 95

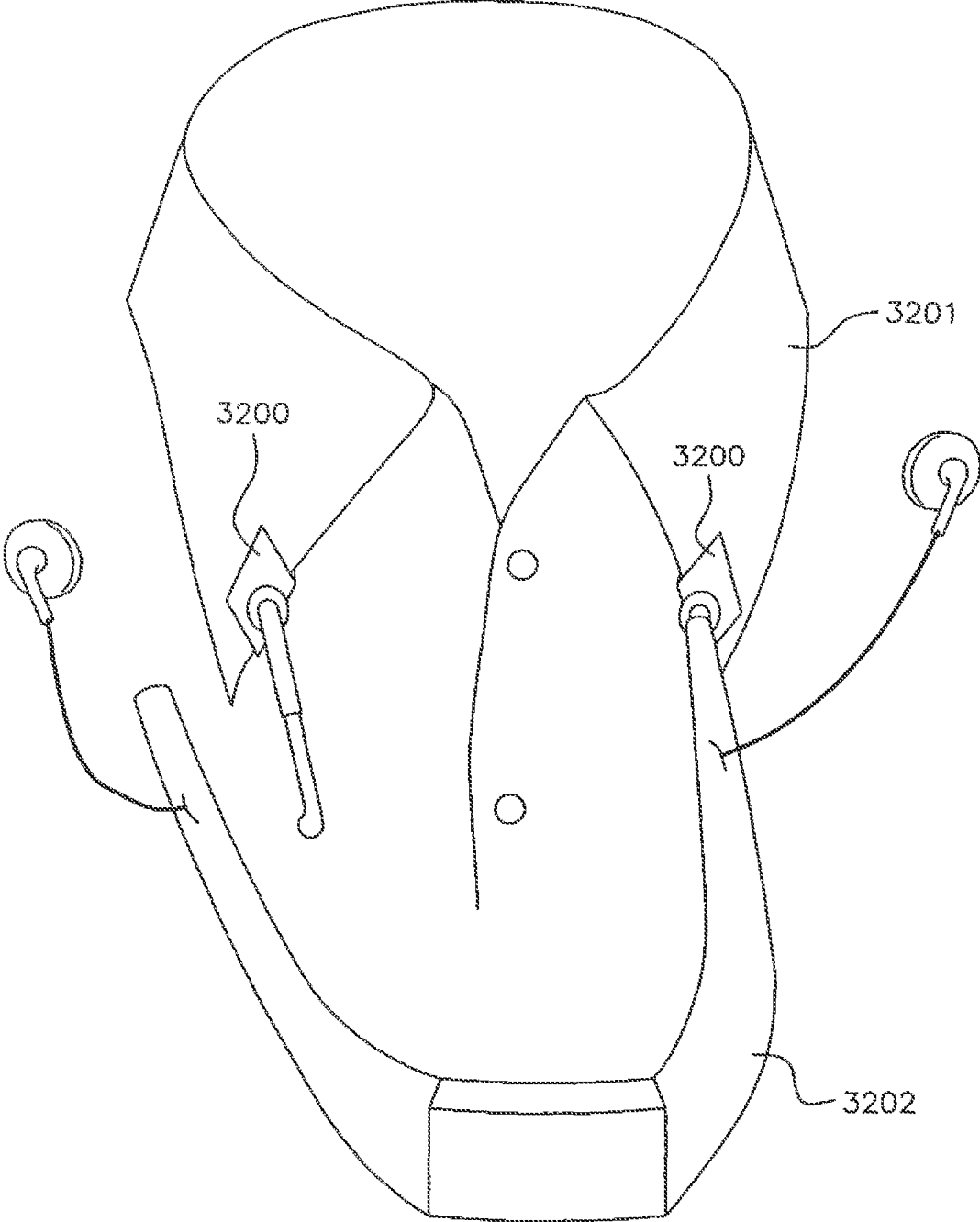

FIG. 96B

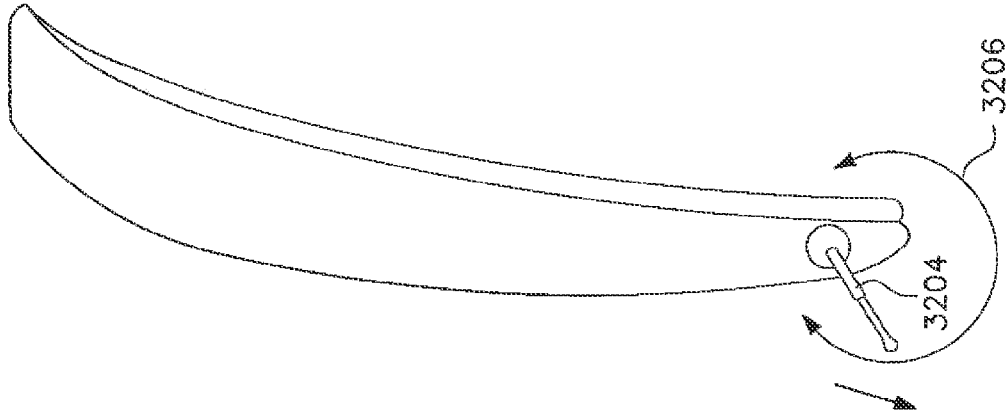

FIG. 96A

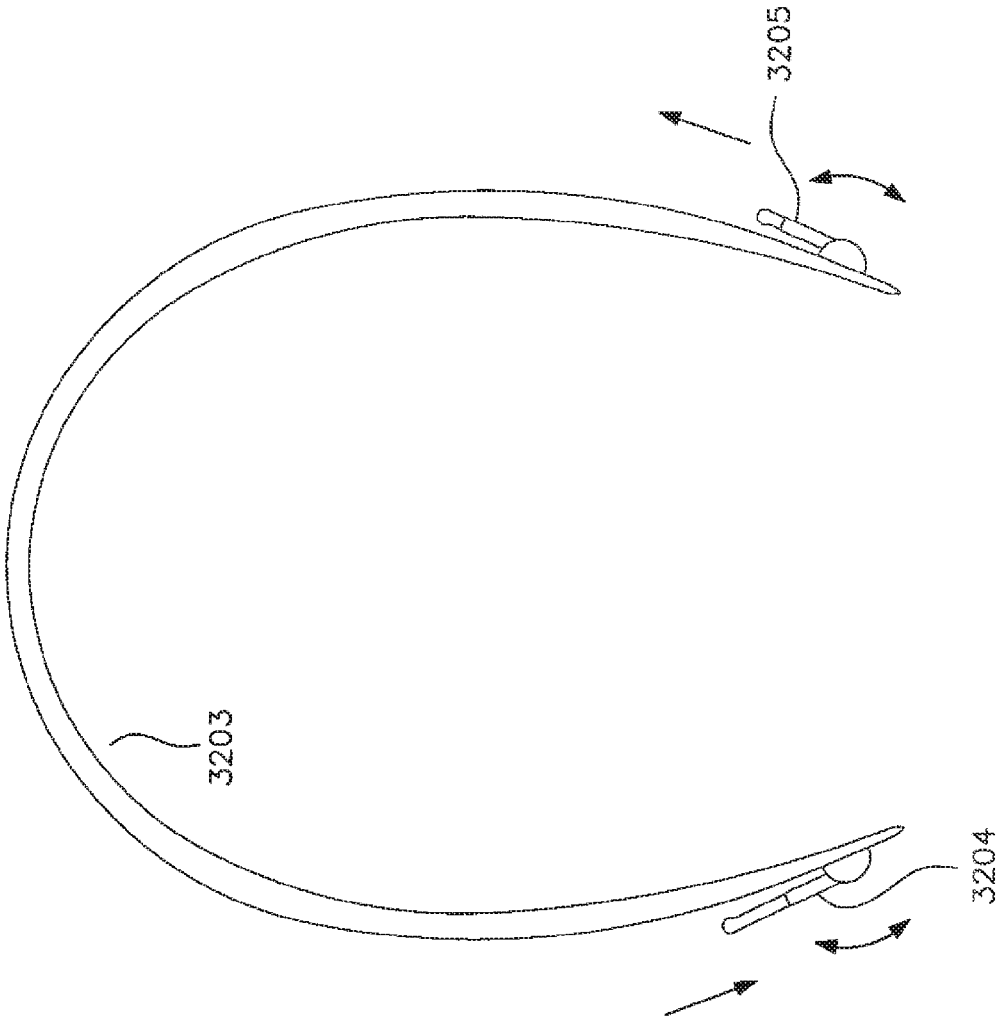

FIG. 97

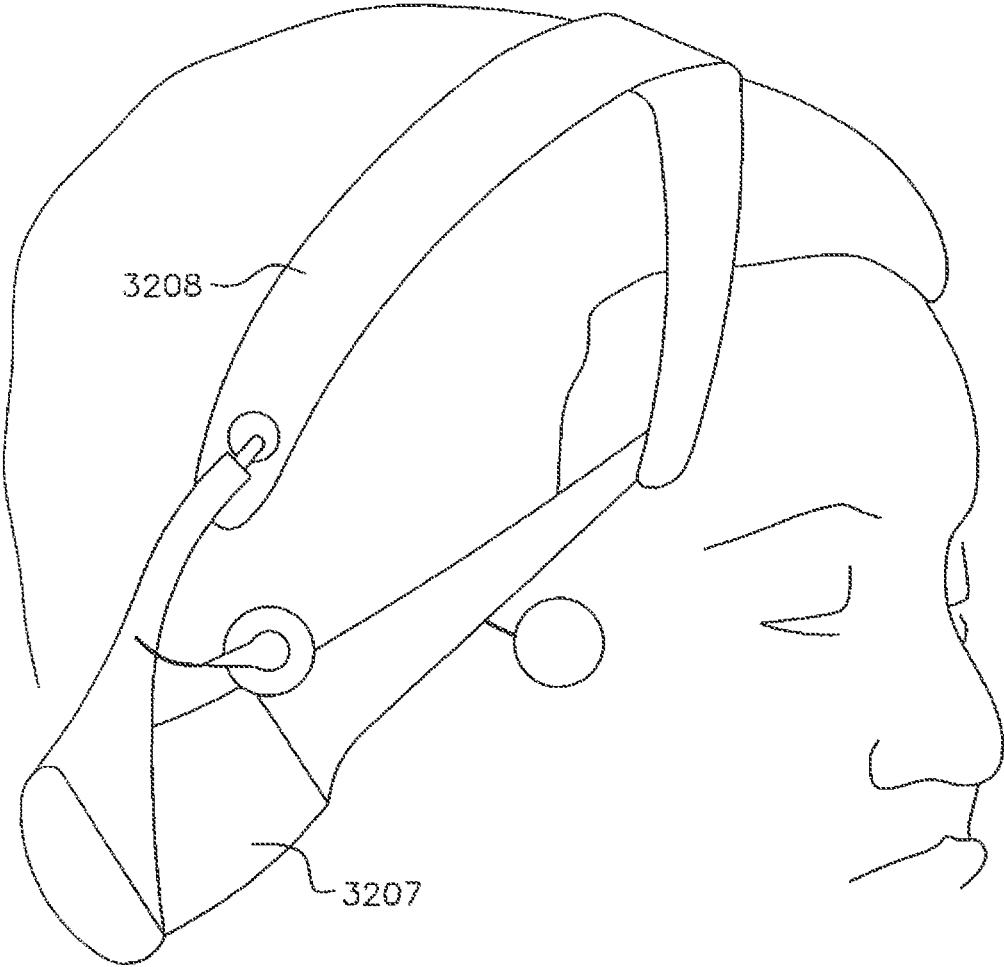

FIG. 98



FIG. 99

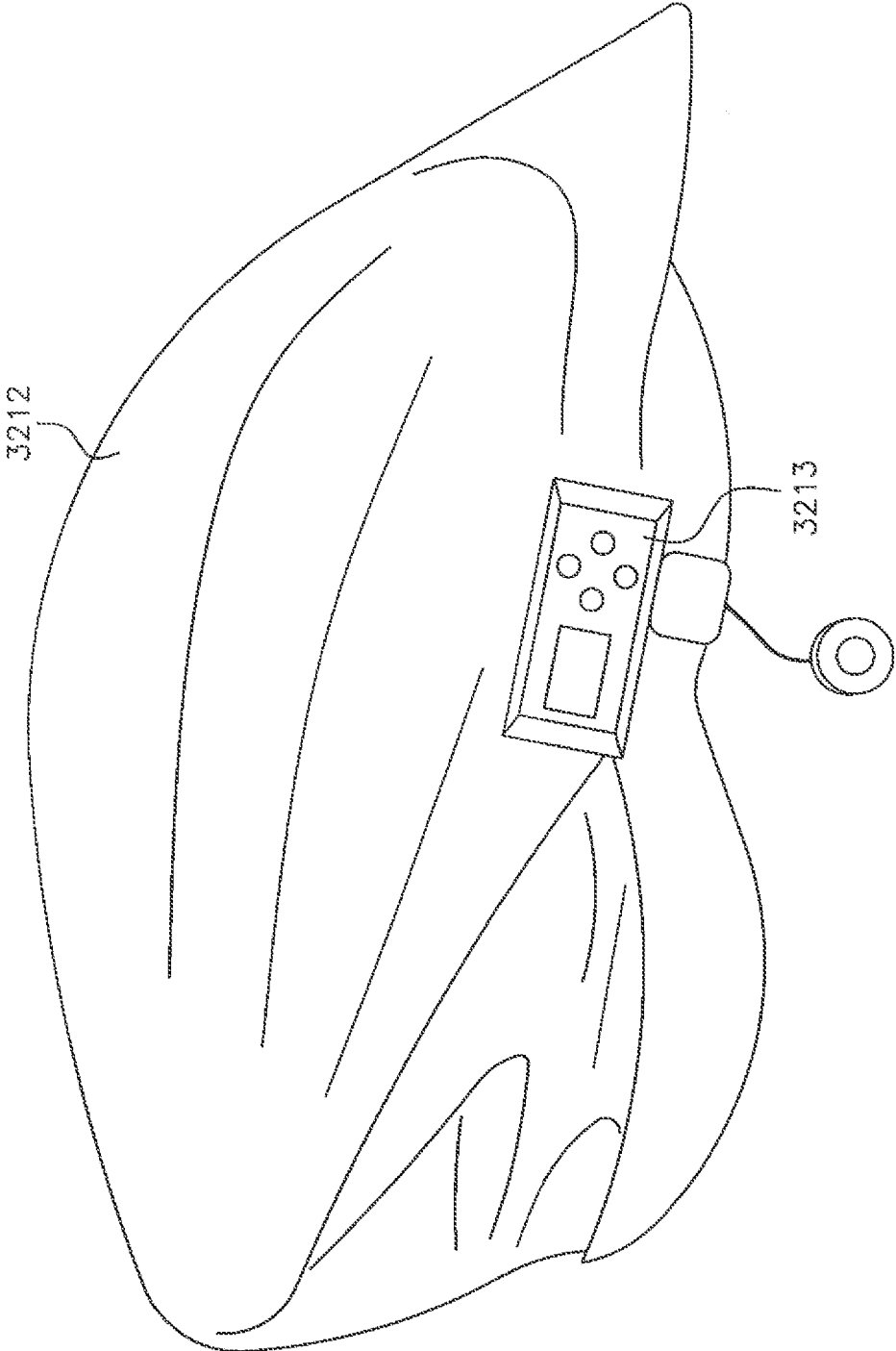

FIG. 100F

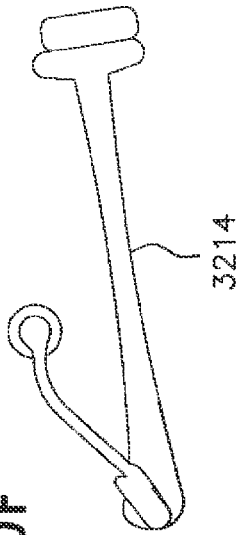

FIG. 100E

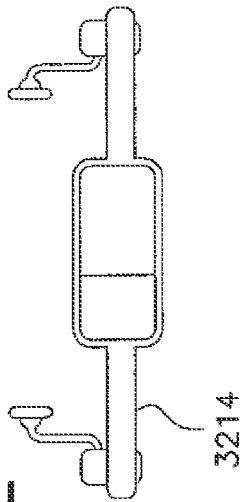

FIG. 100D

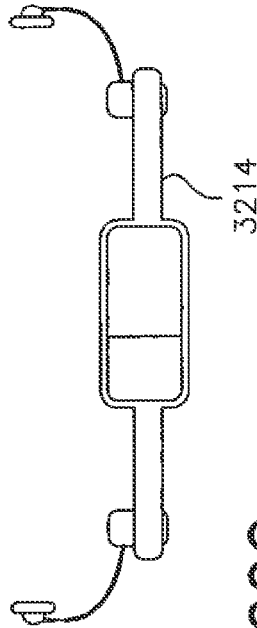

FIG. 100C

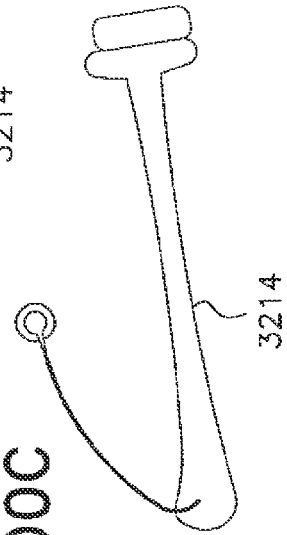

FIG. 100B

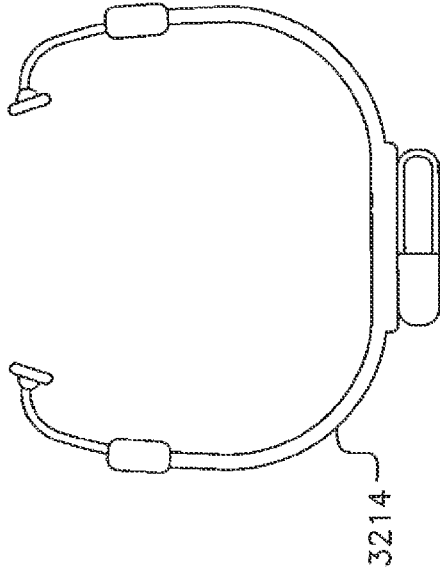

FIG. 100A

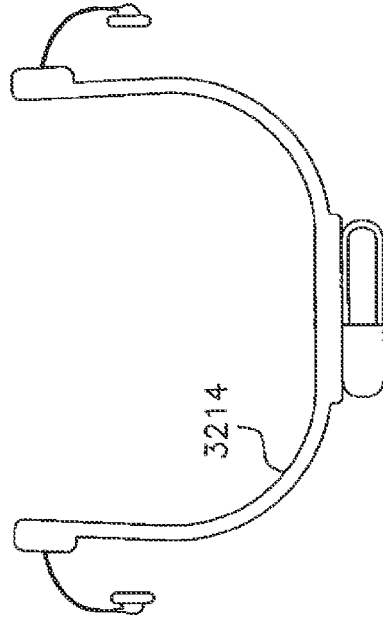

FIG. 101A

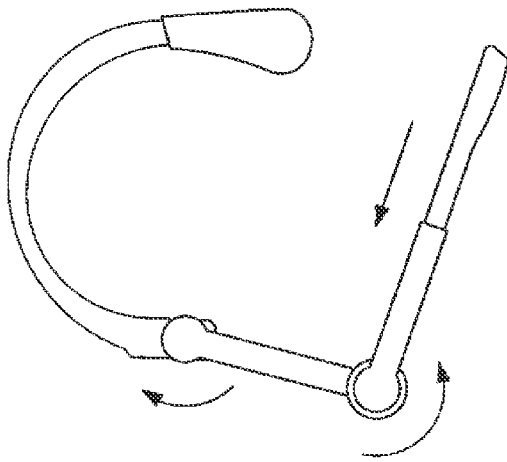

FIG. 101B

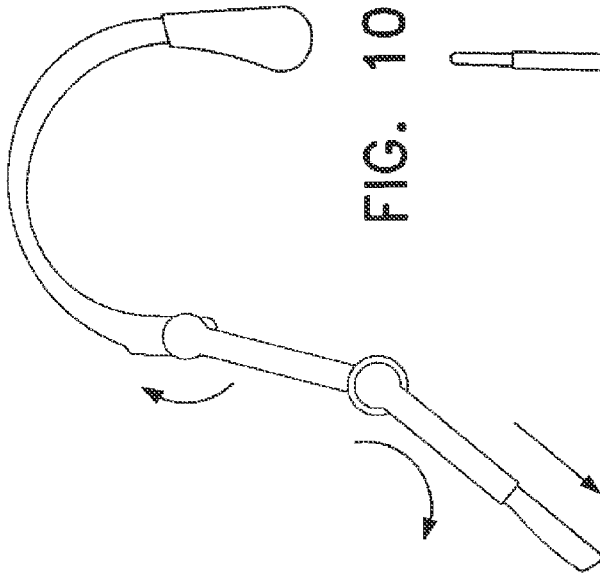

FIG. 101D

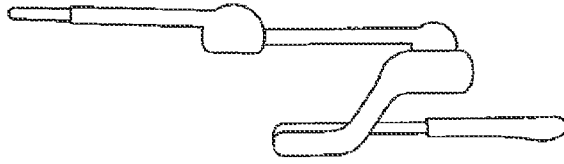

FIG. 101C

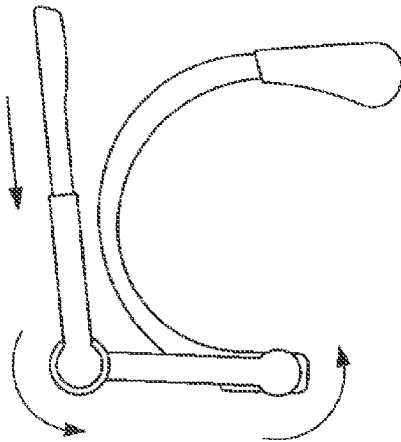

FIG. 102A

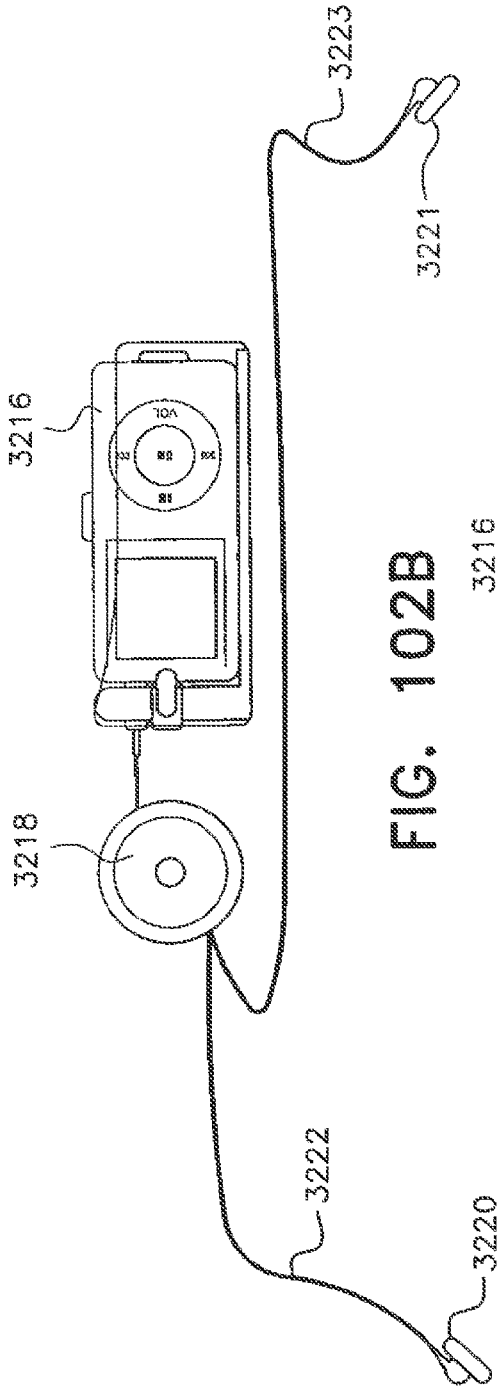

FIG. 102B

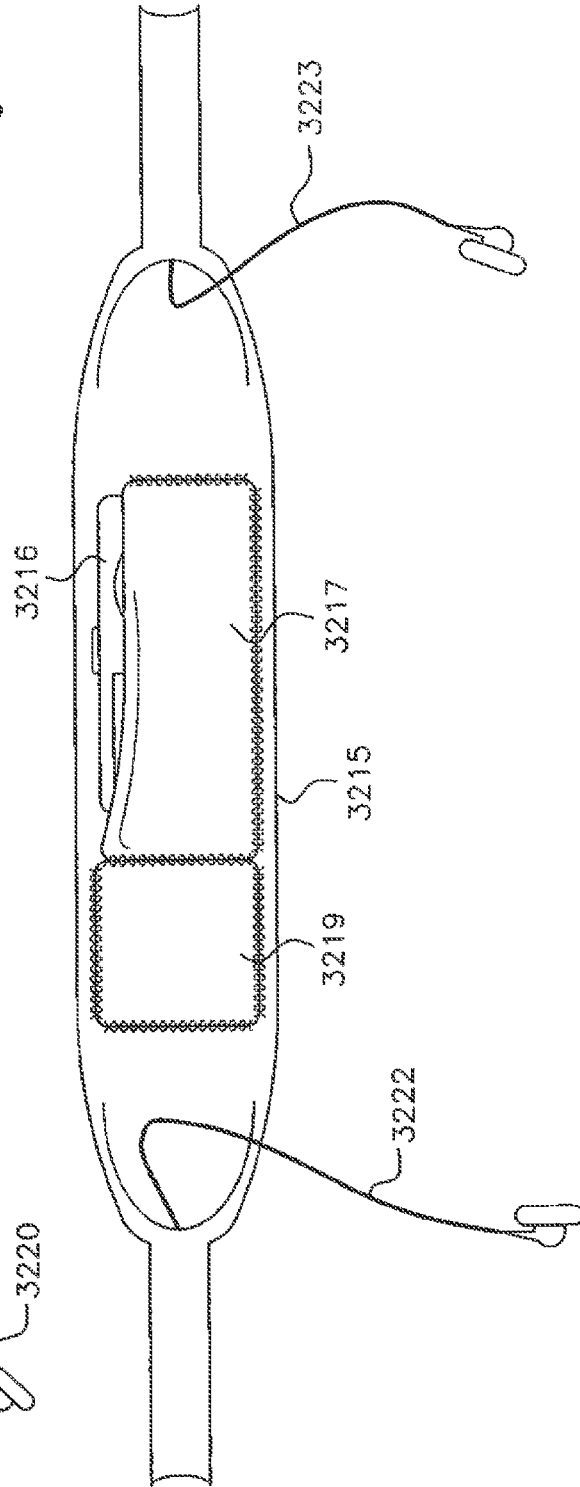

FIG. 102C

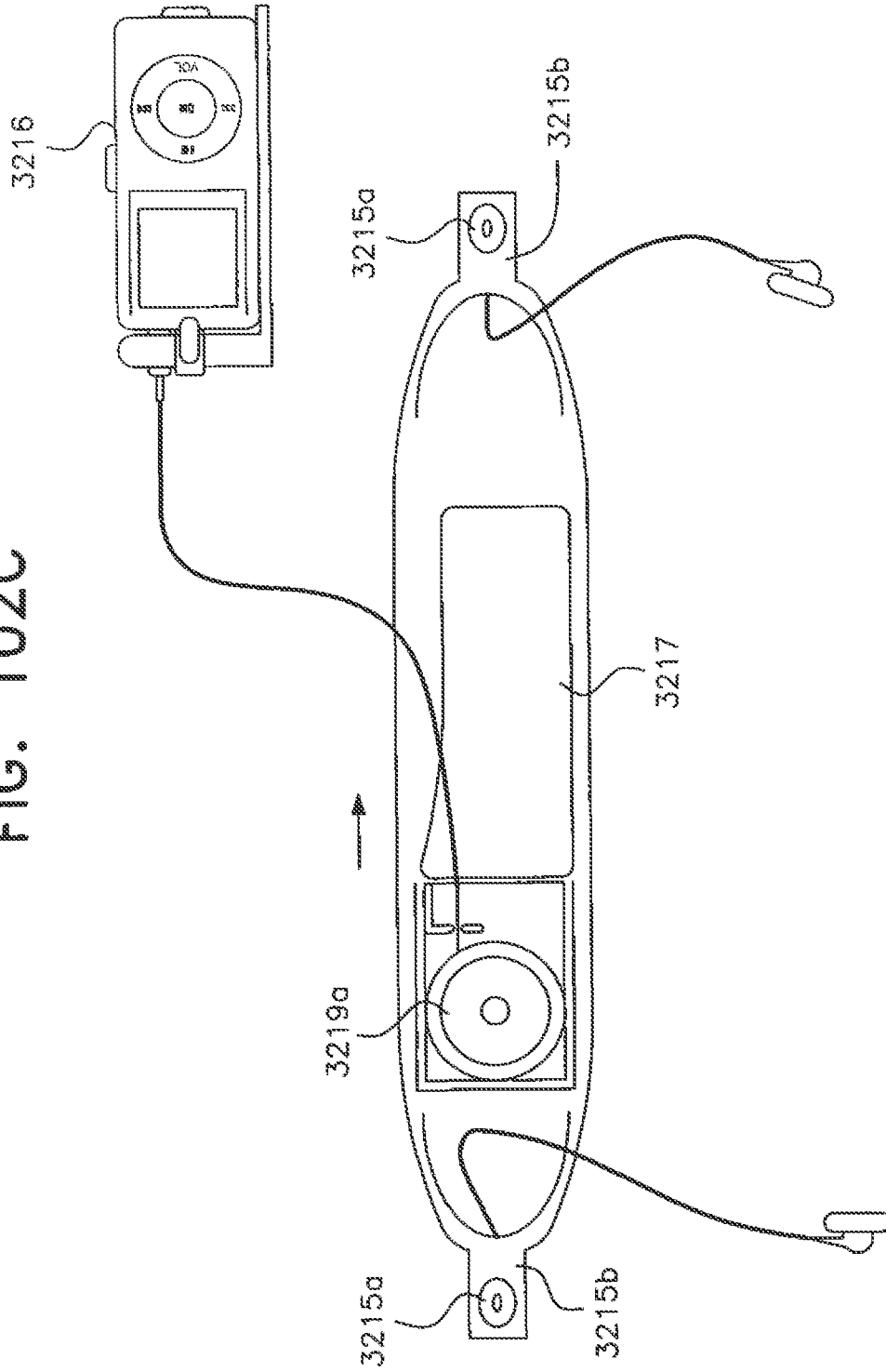

FIG. 103

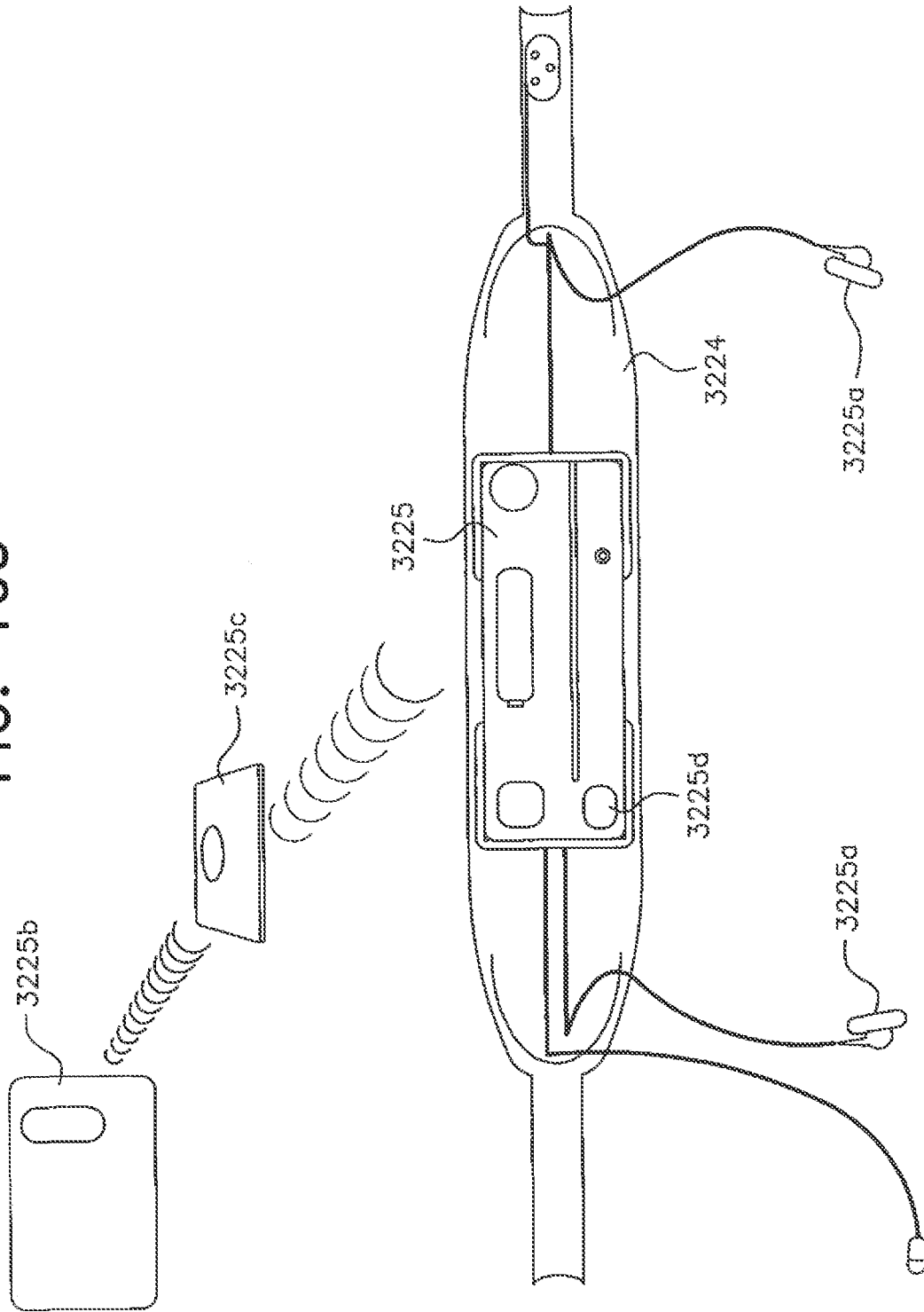

FIG. 104B

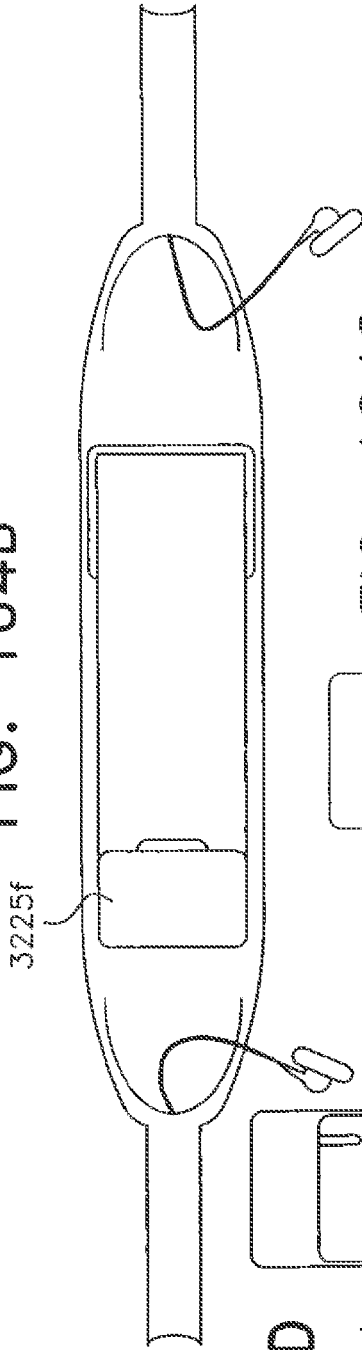

FIG. 104C

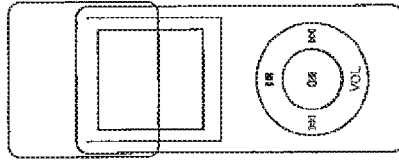

FIG. 104D

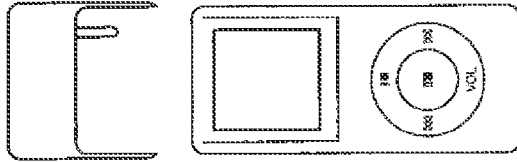

FIG. 104A

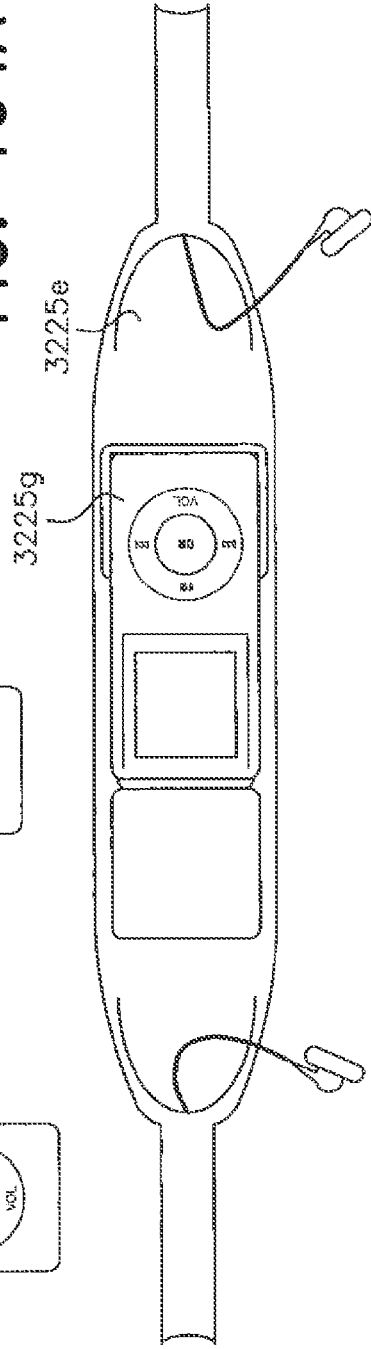

FIG. 105

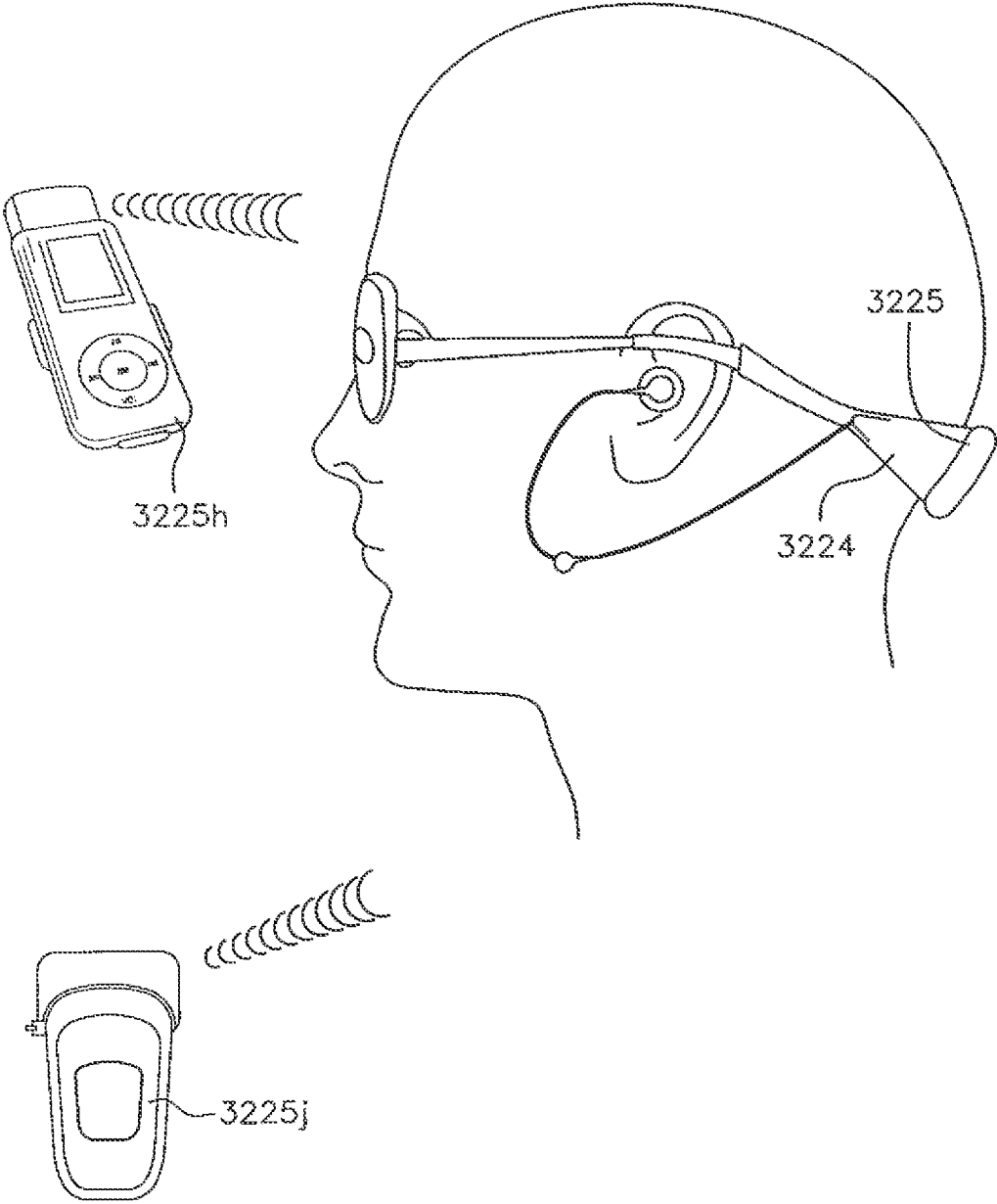

FIG. 106

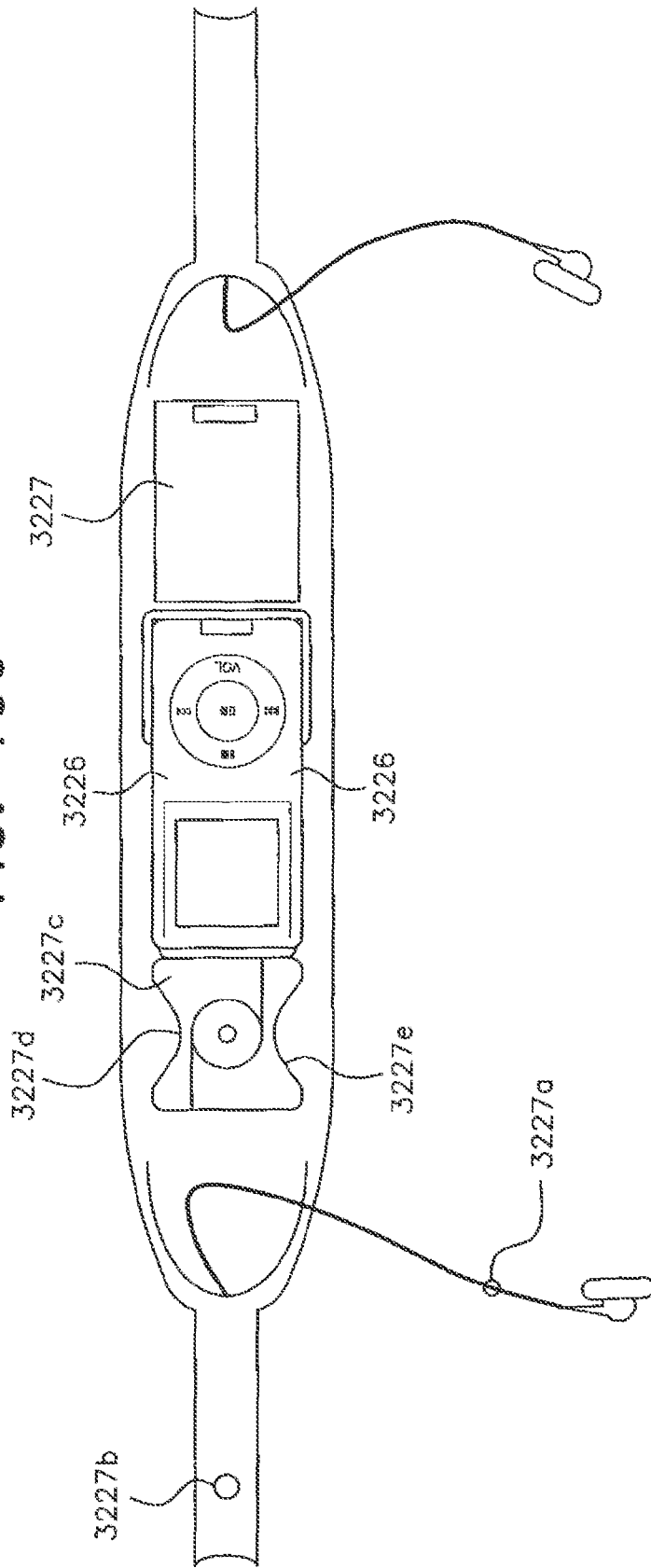

FIG. 106A

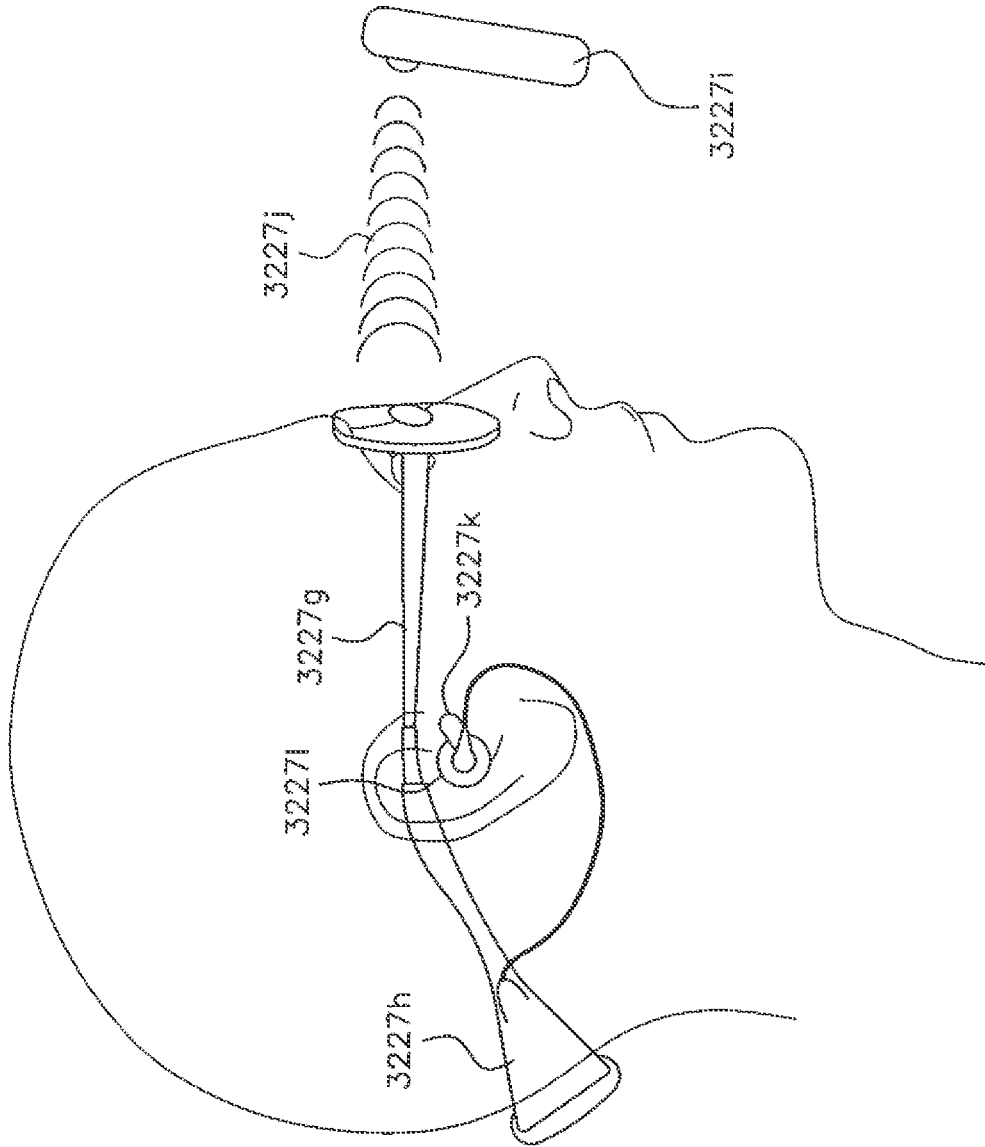

FIG. 106B

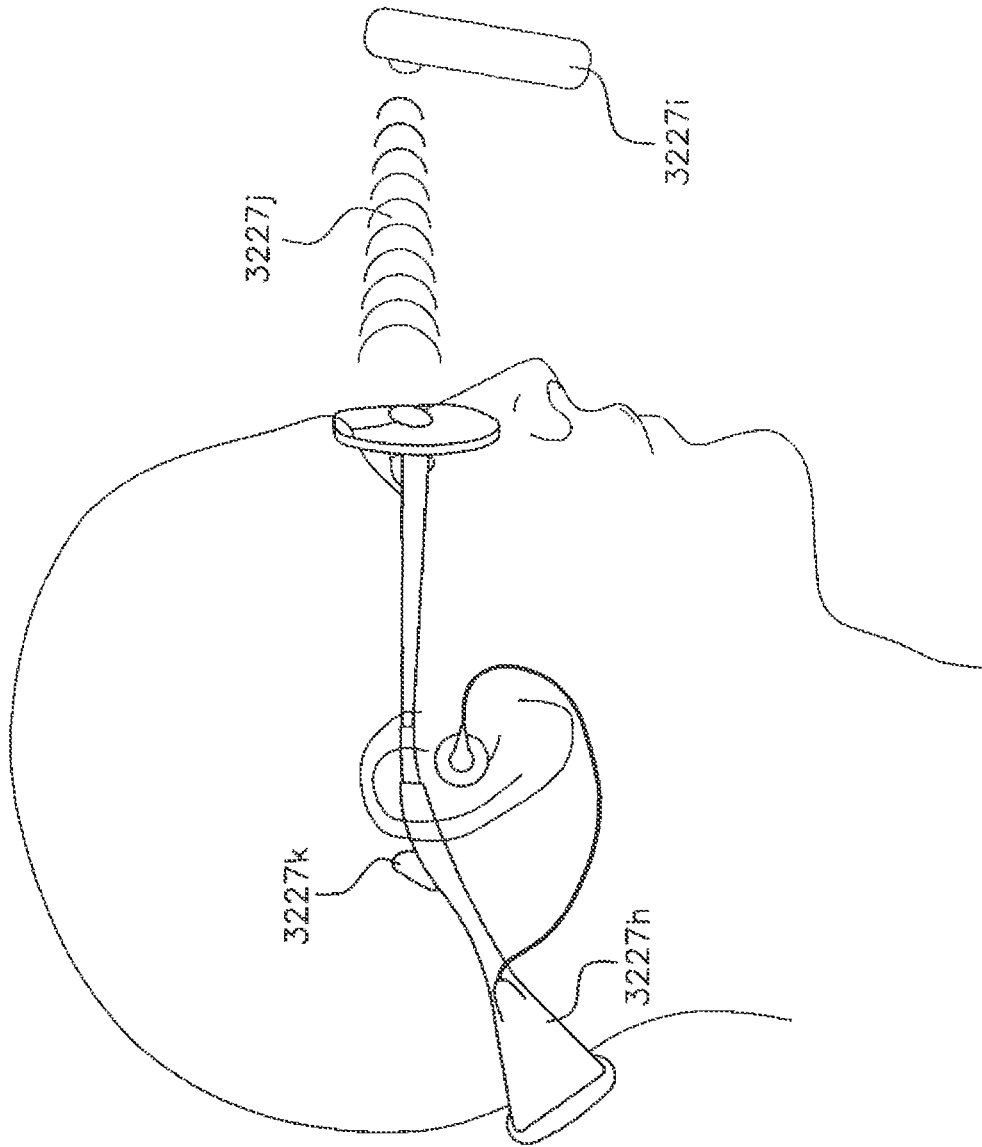

FIG. 107

3227

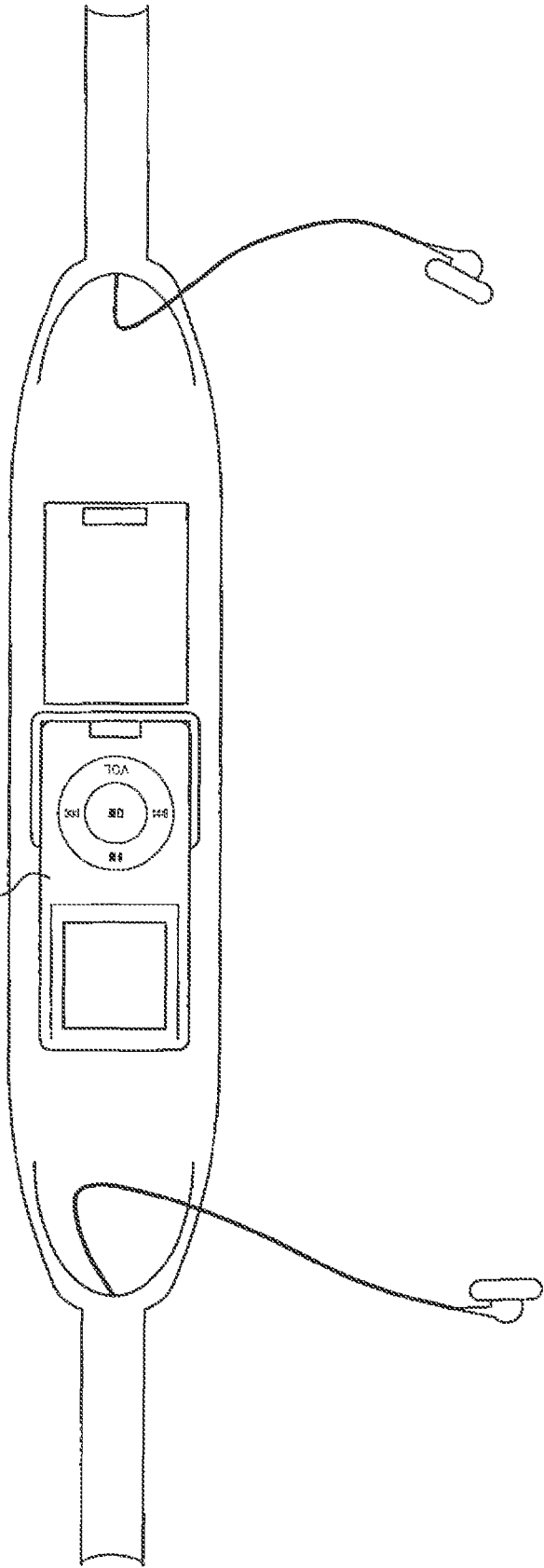
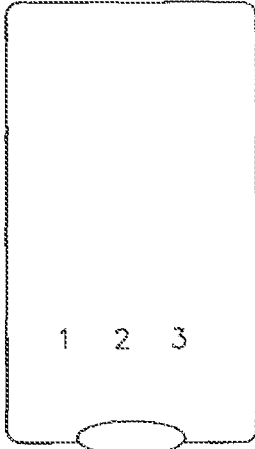
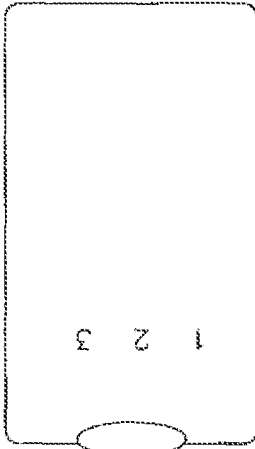

FIG. 108A

FIG. 108B



3228

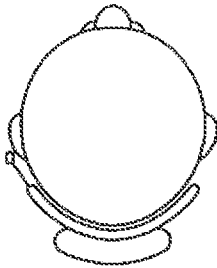
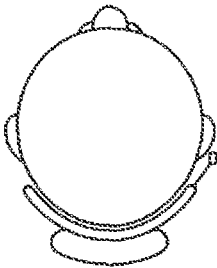

FIG. 109

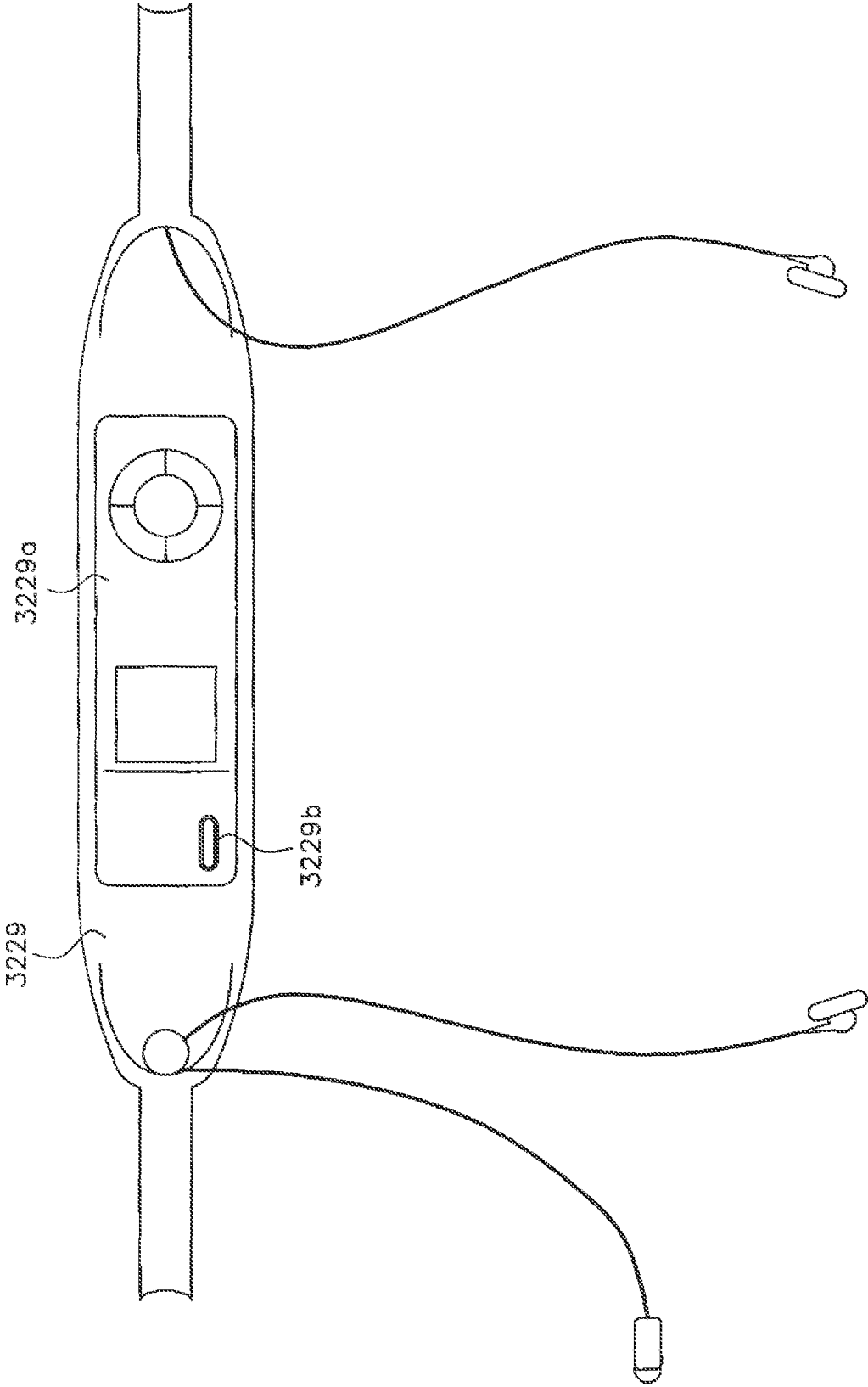

FIG. 110

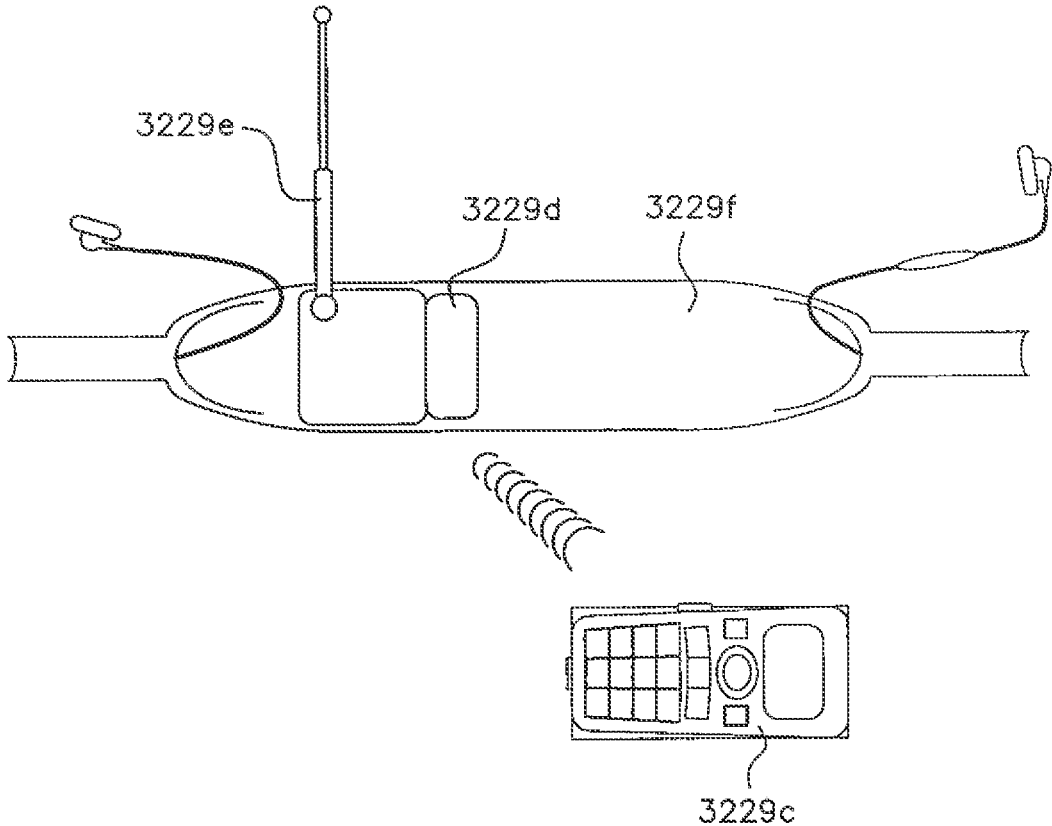

FIG. 111

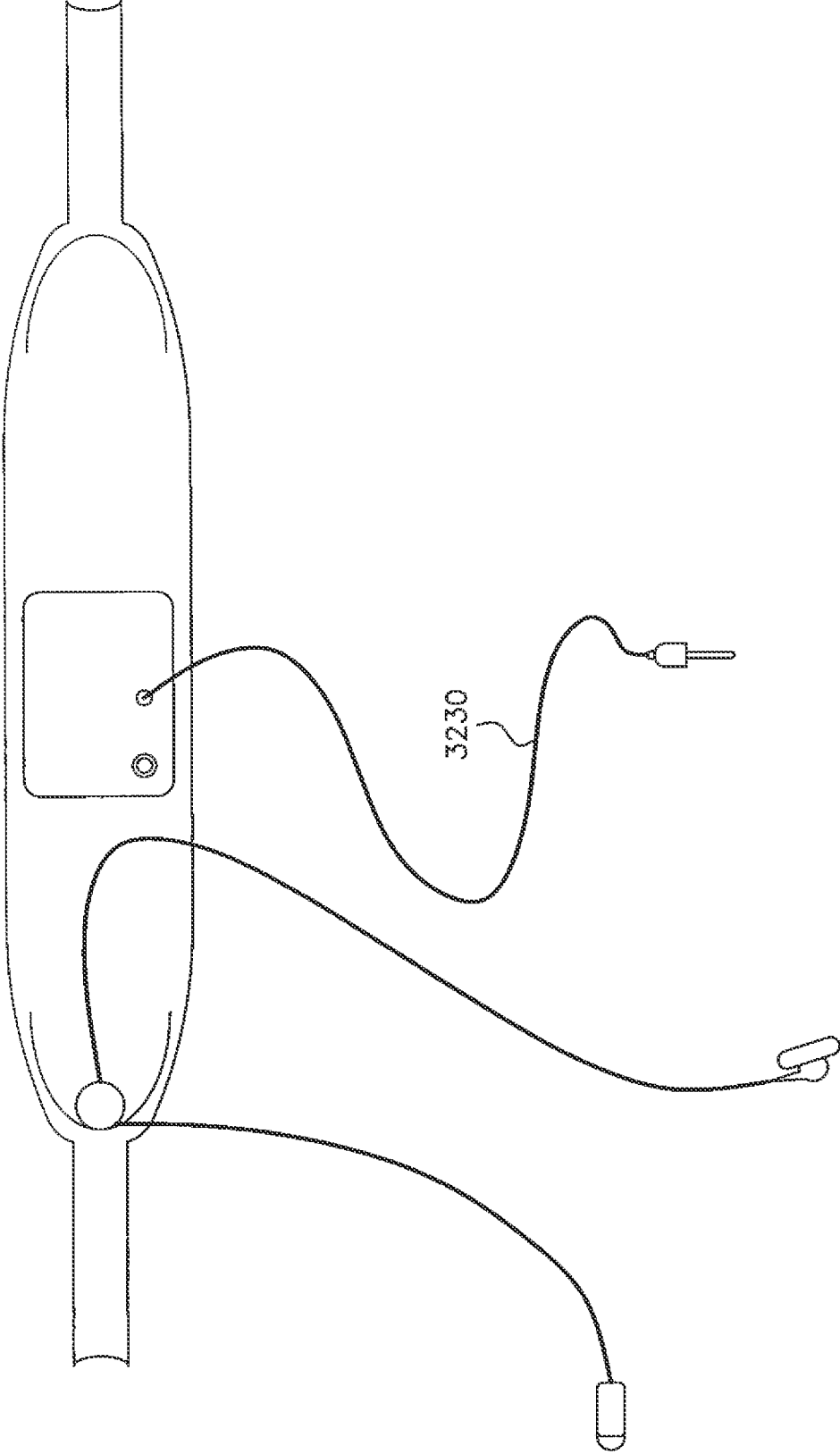

FIG. 112

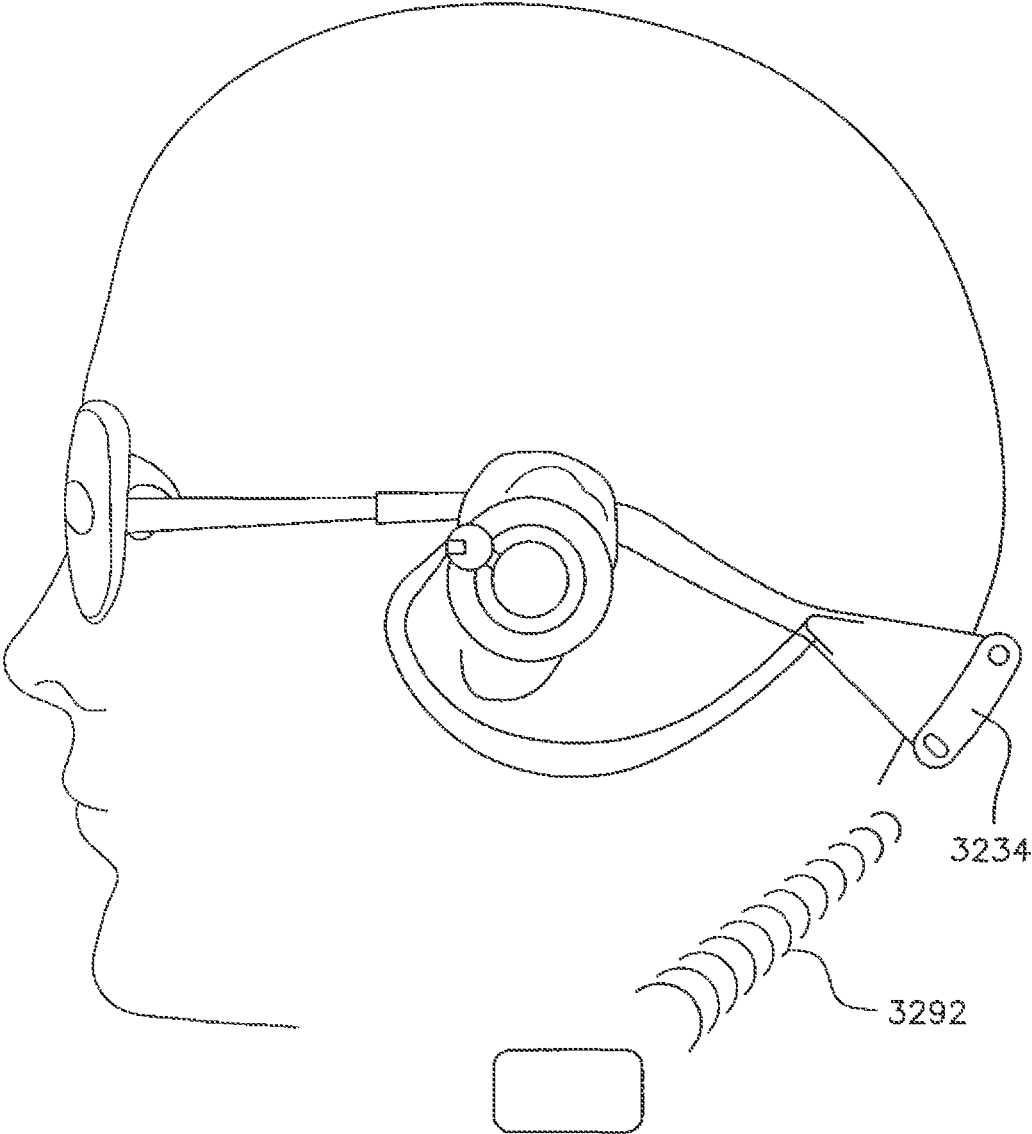

FIG. 113

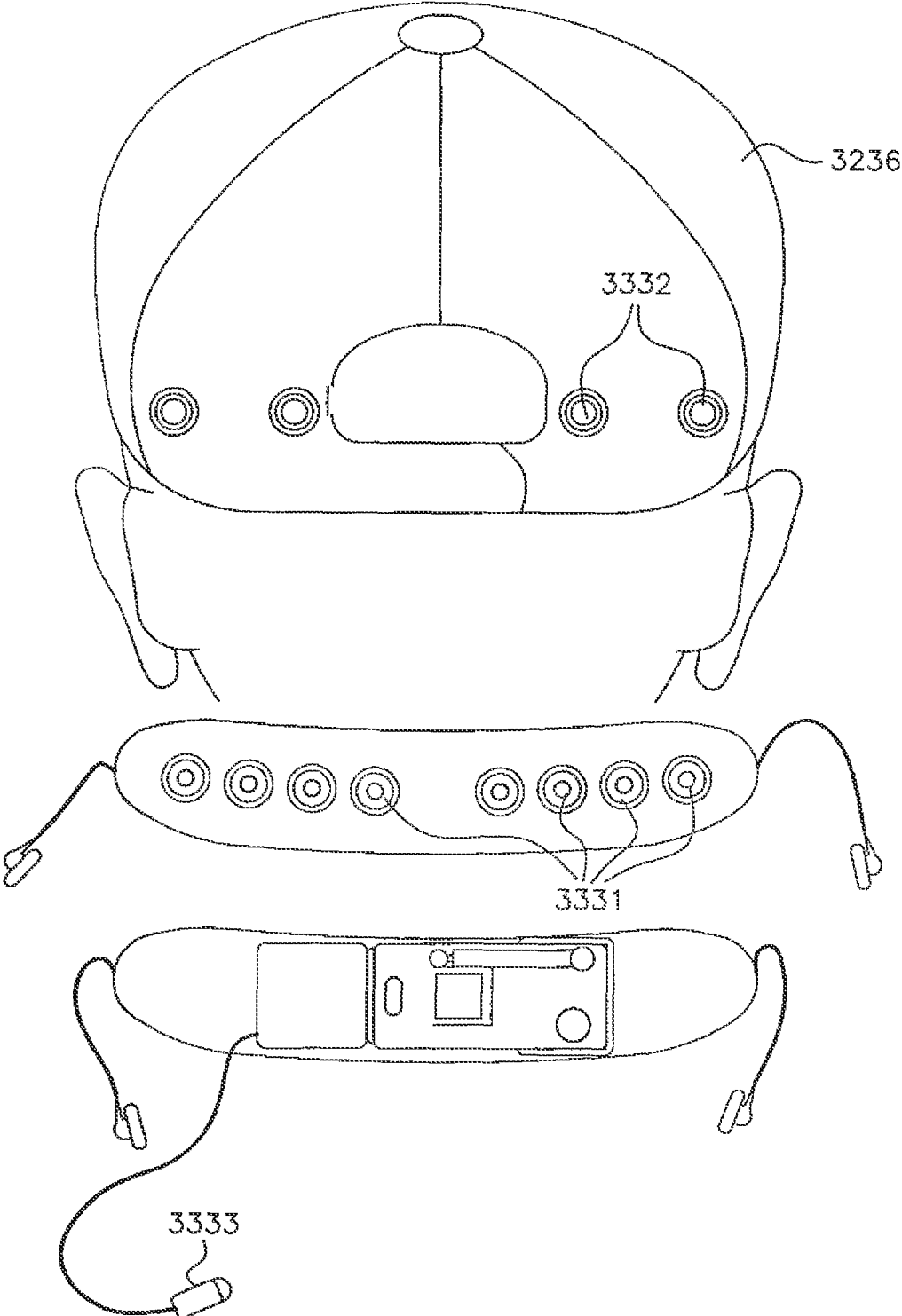

FIG. 114

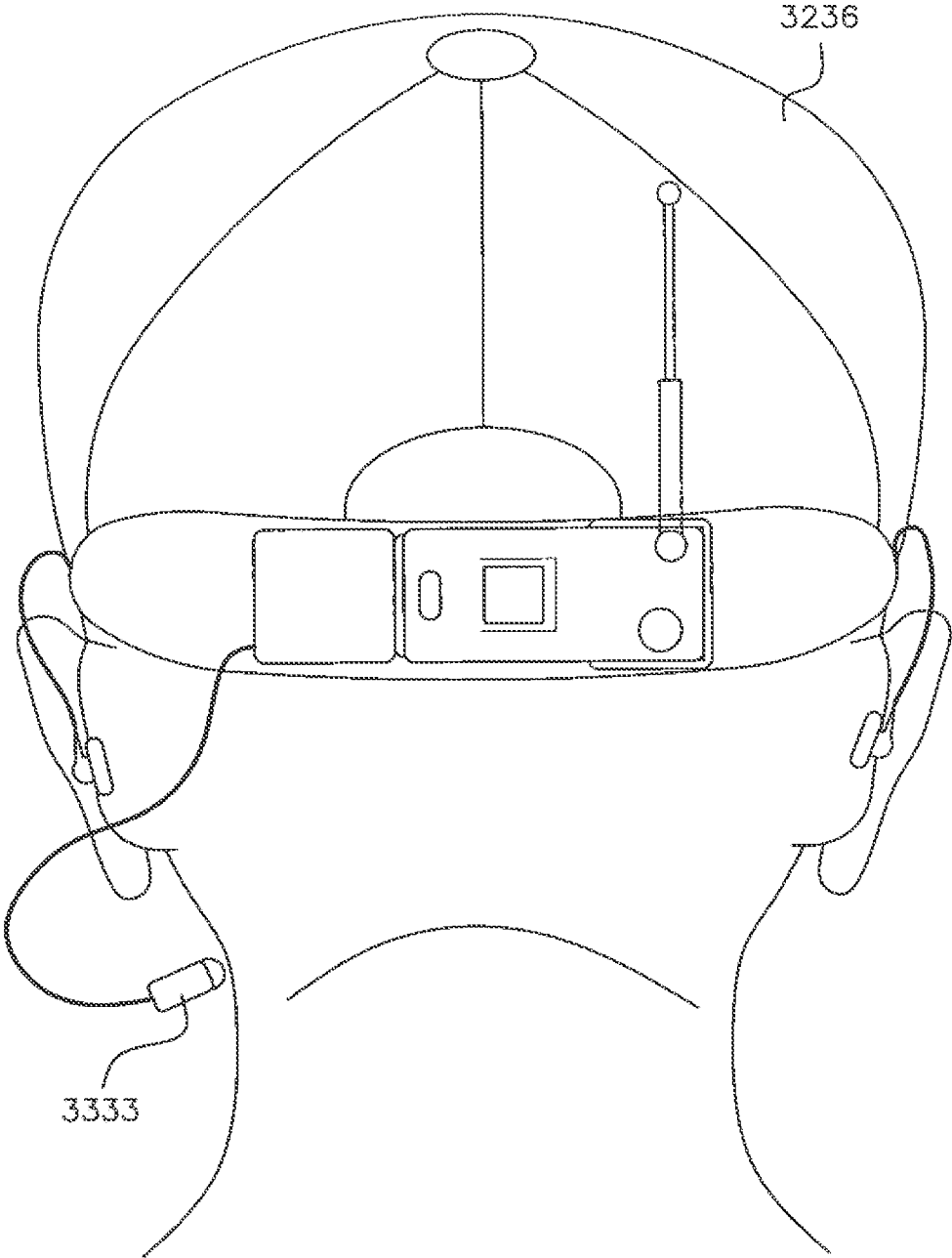

FIG. 115

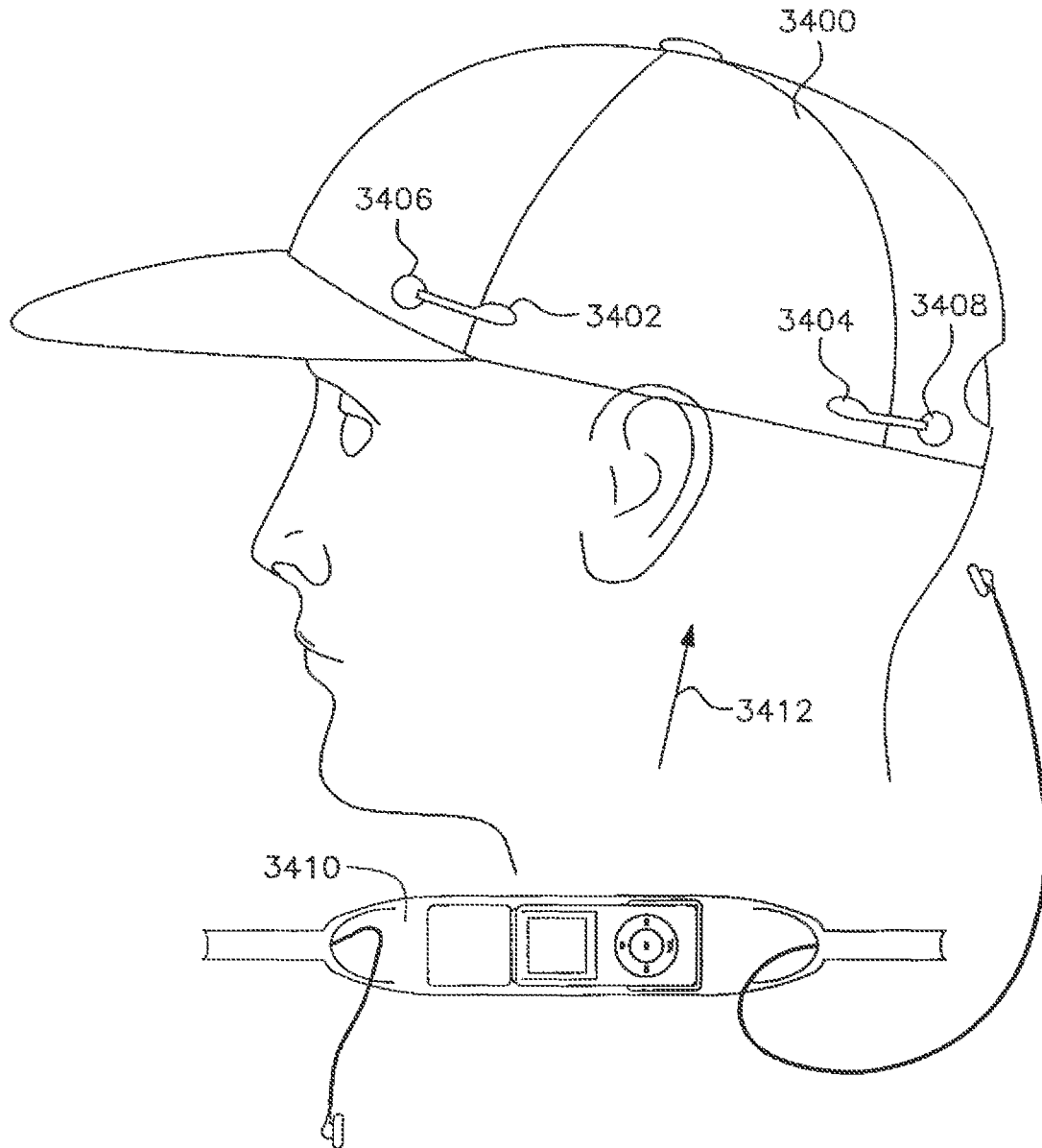

FIG. 116

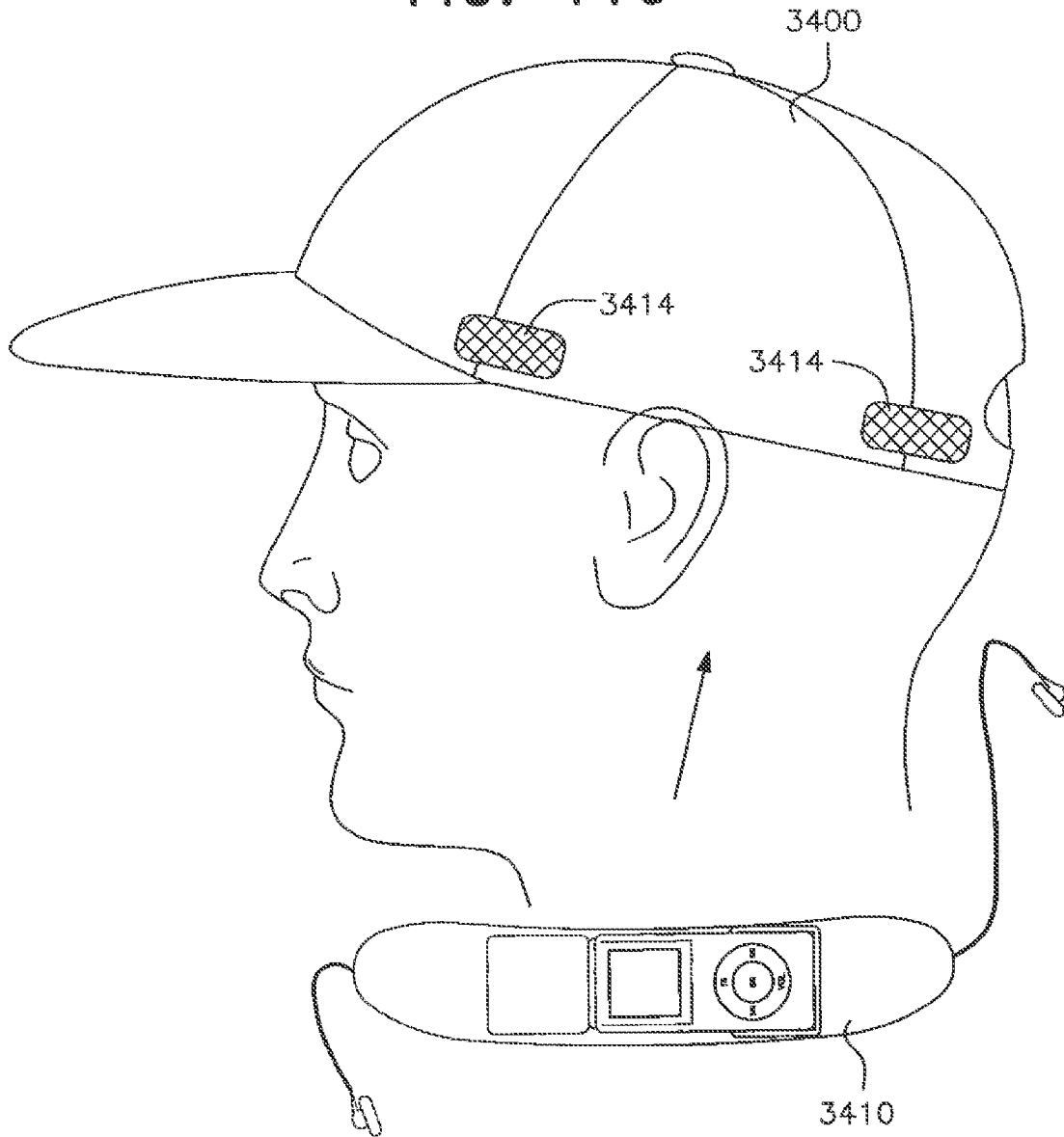

FIG. 117A

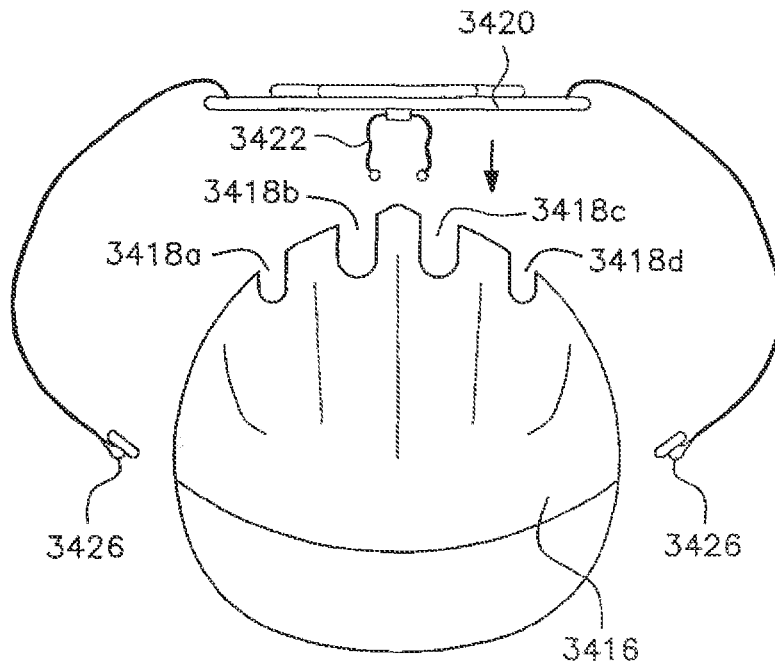

FIG. 117B

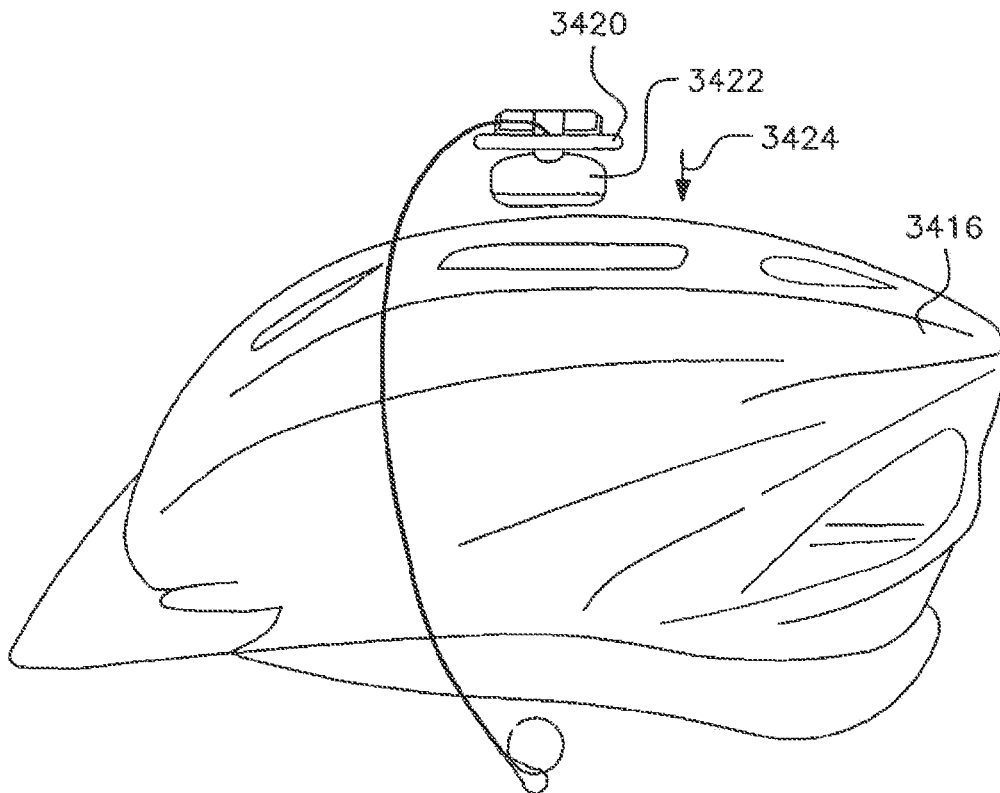

FIG. 118

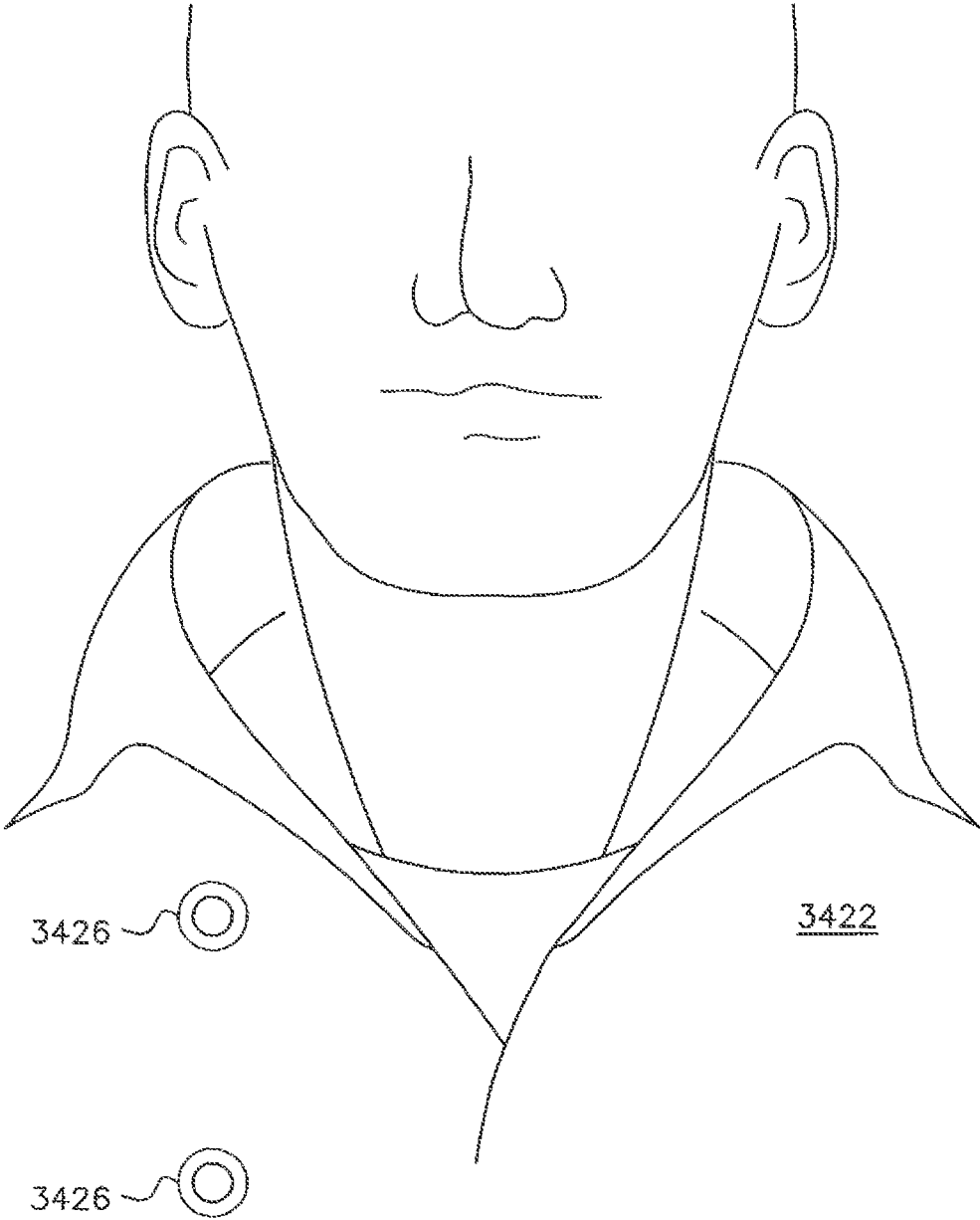

FIG. 119

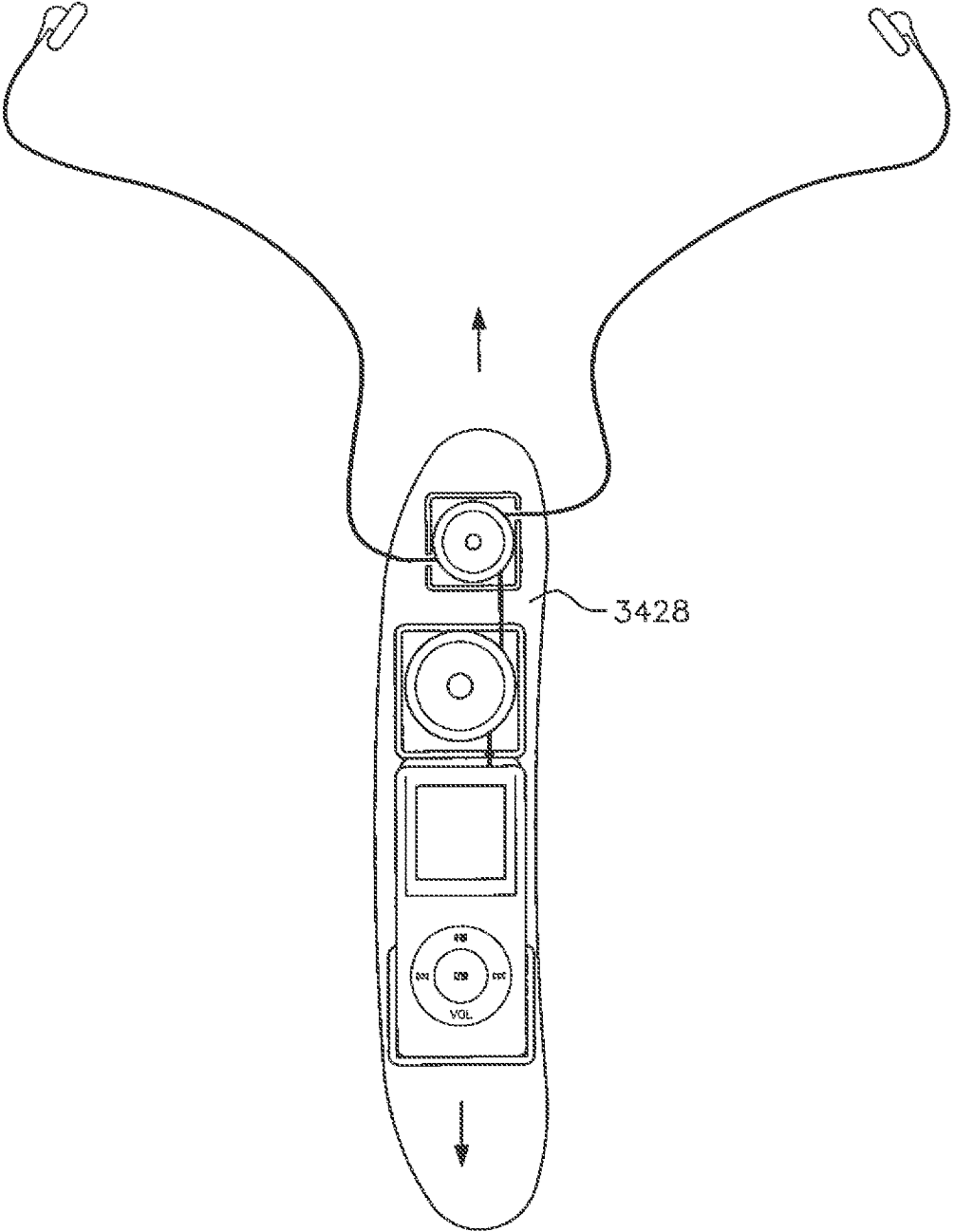

FIG. 120

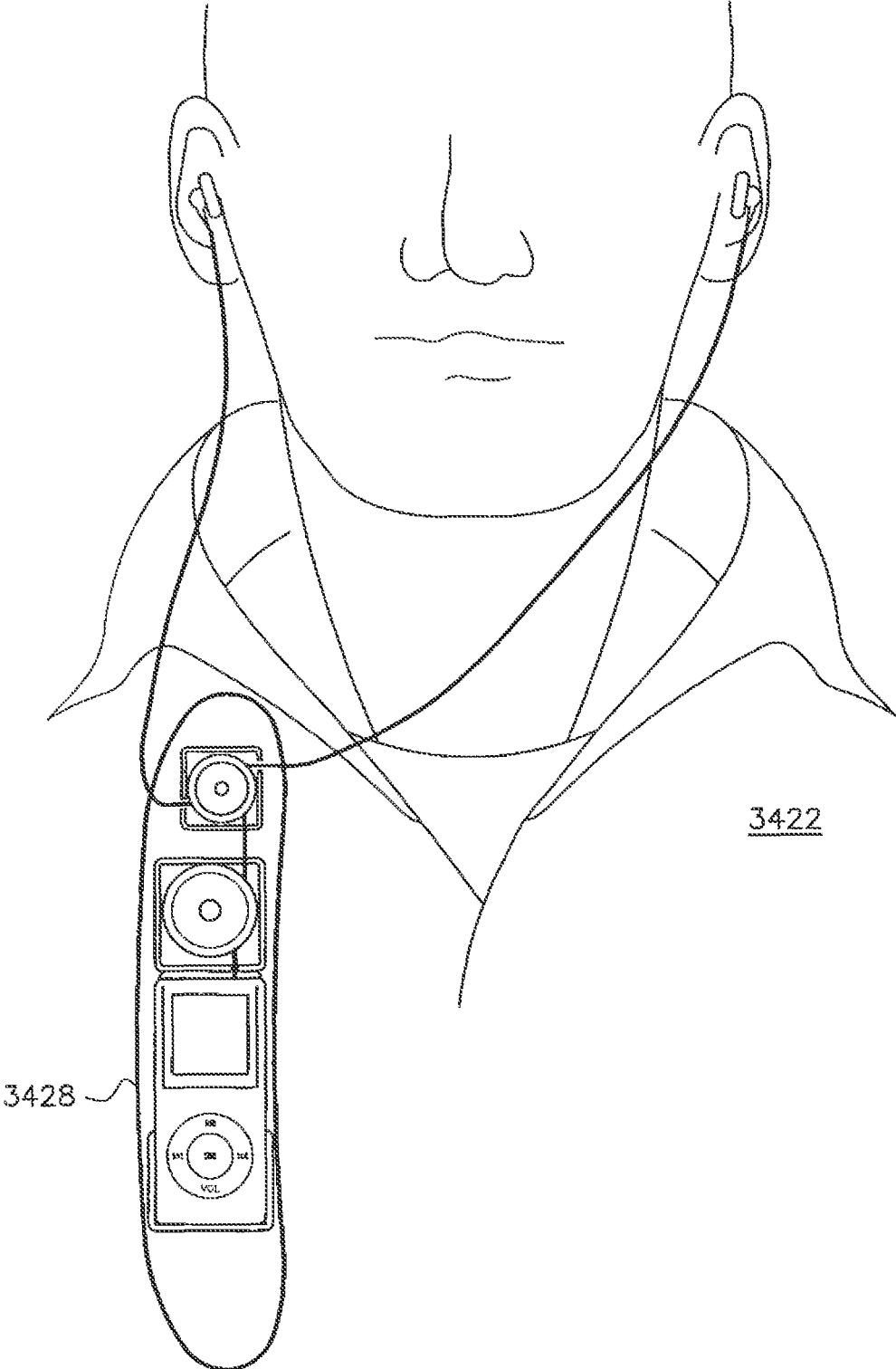

FIG. 121A

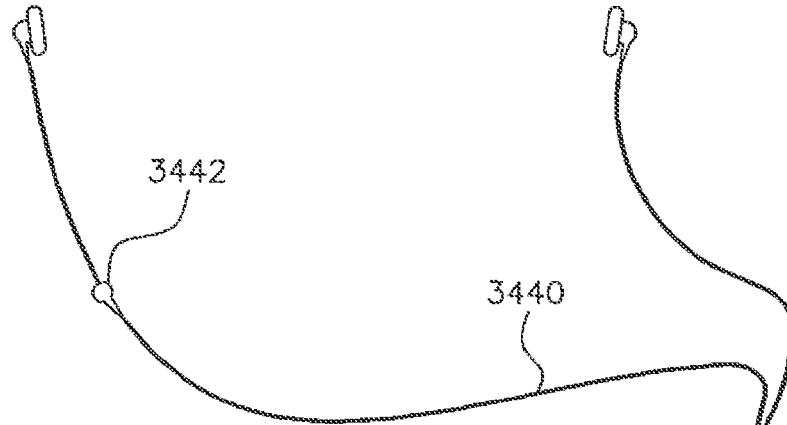

FIG. 121B

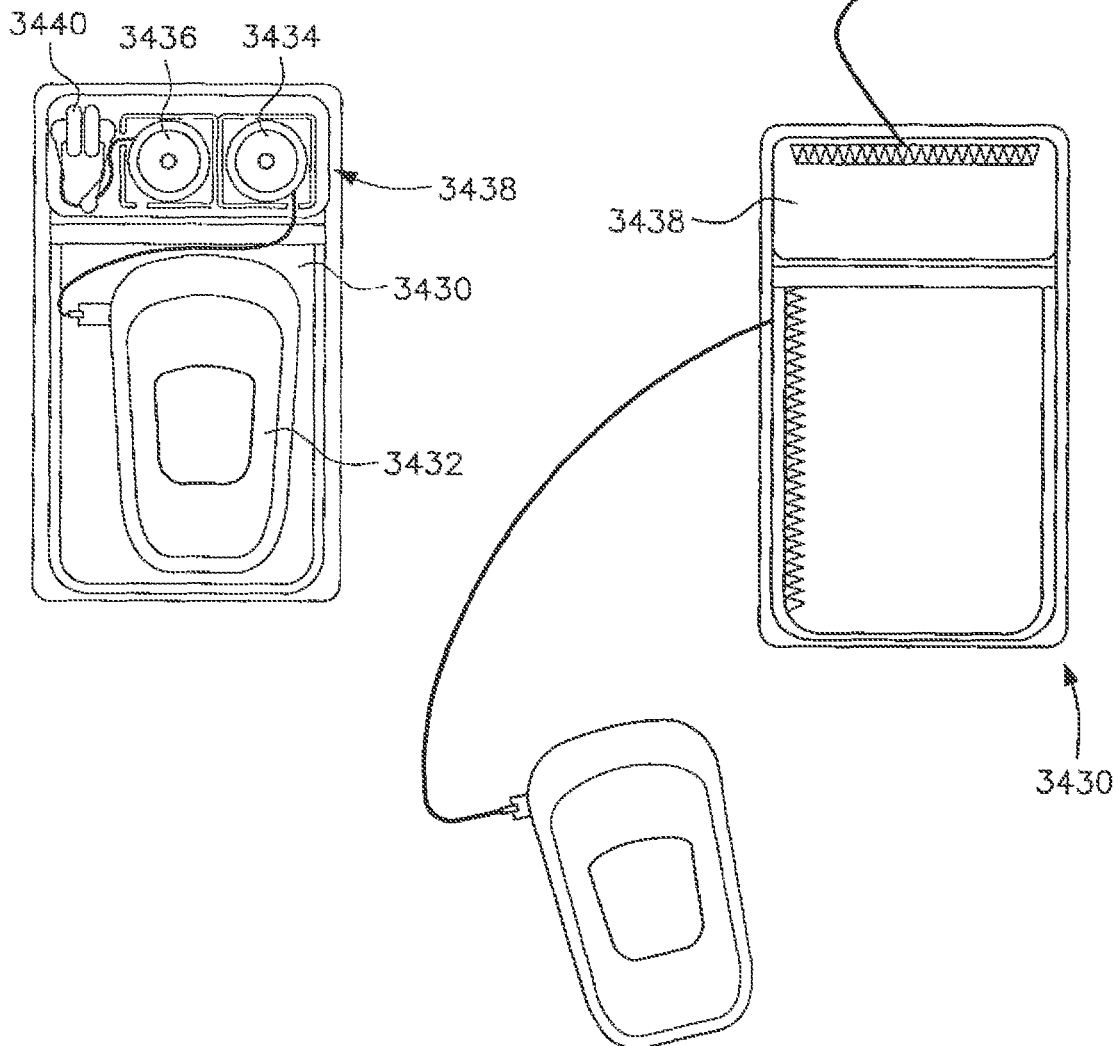

FIG. 121C

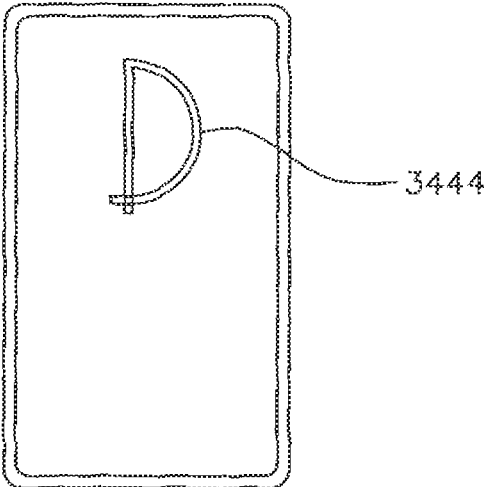

FIG. 121D

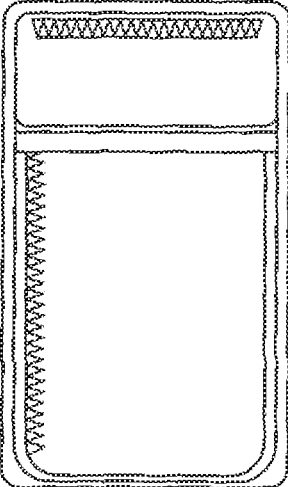

FIG. 121E

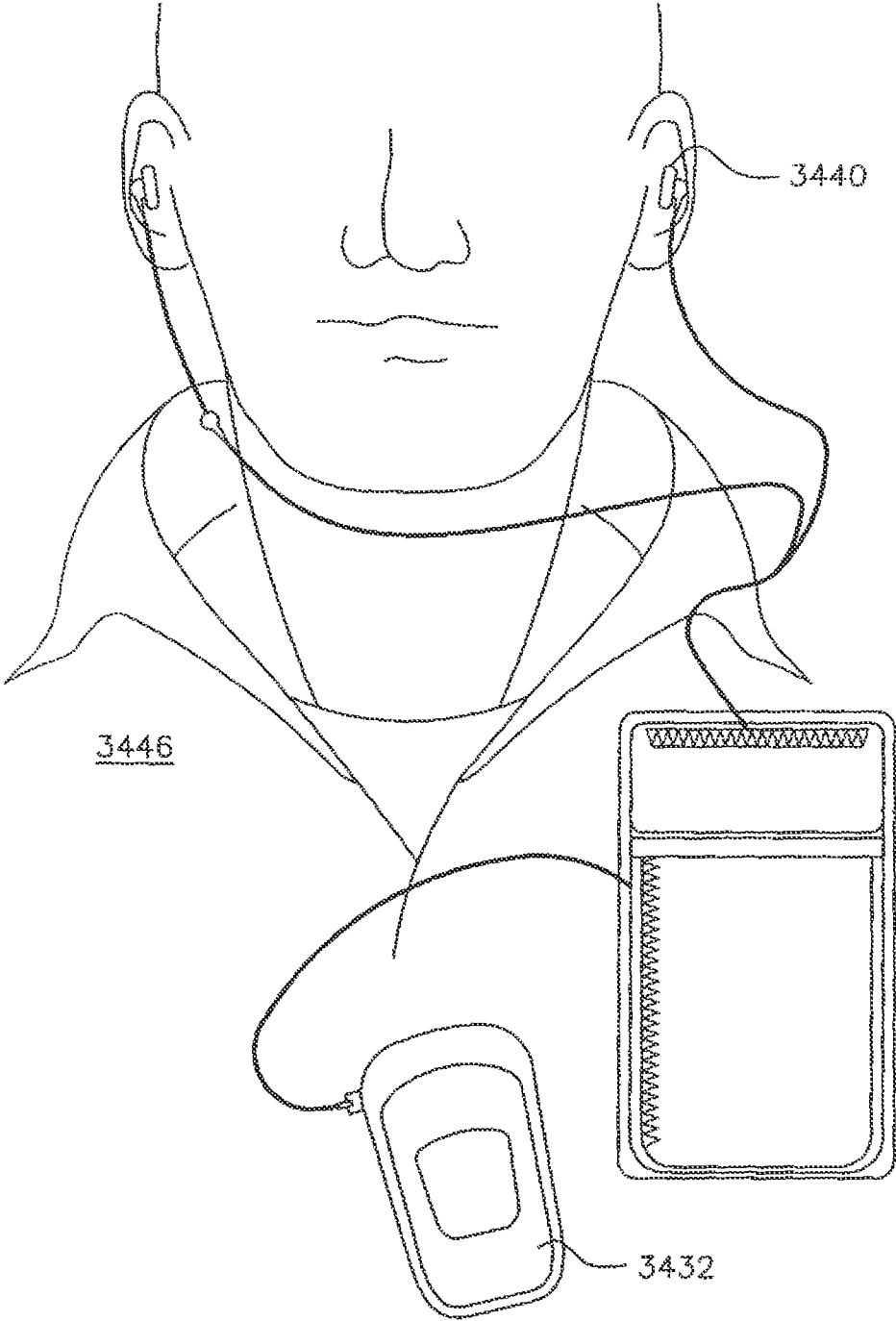

FIG. 122D

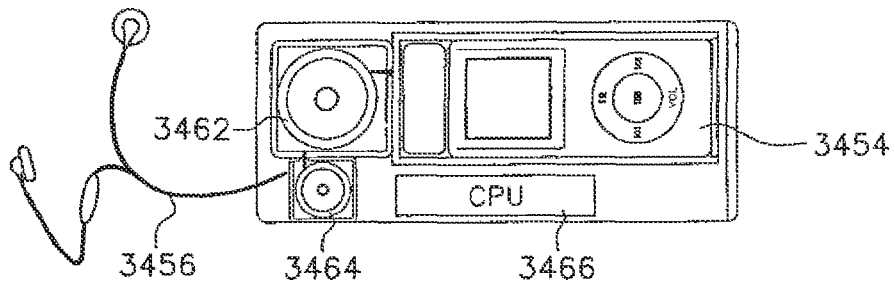

FIG. 122C

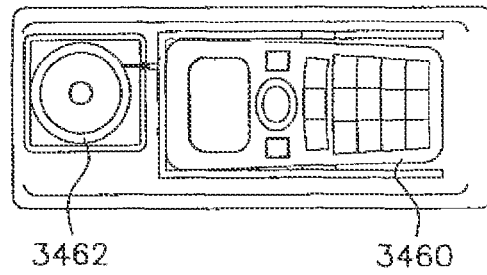

FIG. 122A

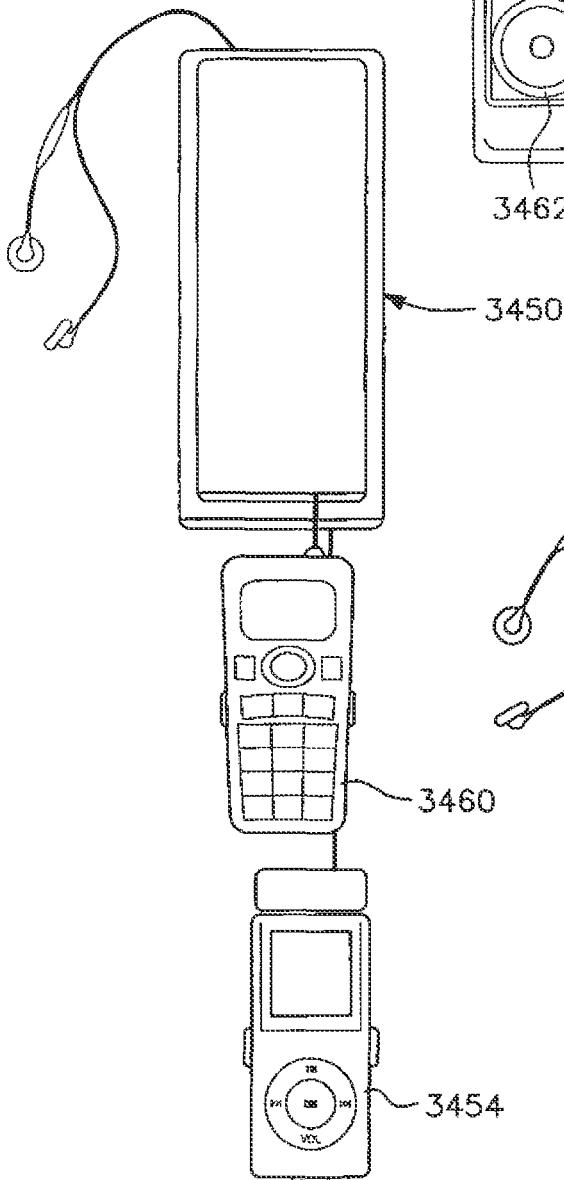

FIG. 122B

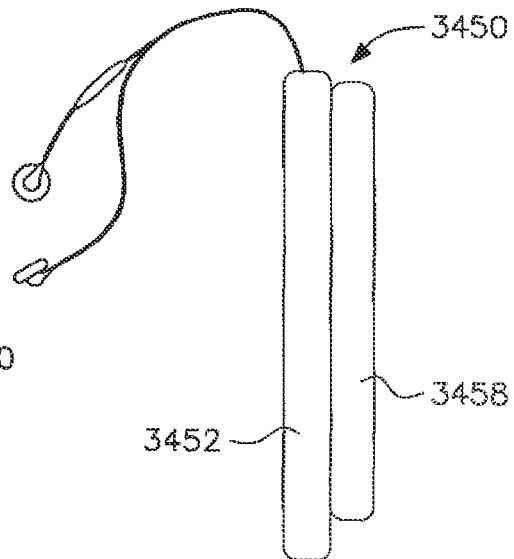

FIG. 123A

FIG. 123B

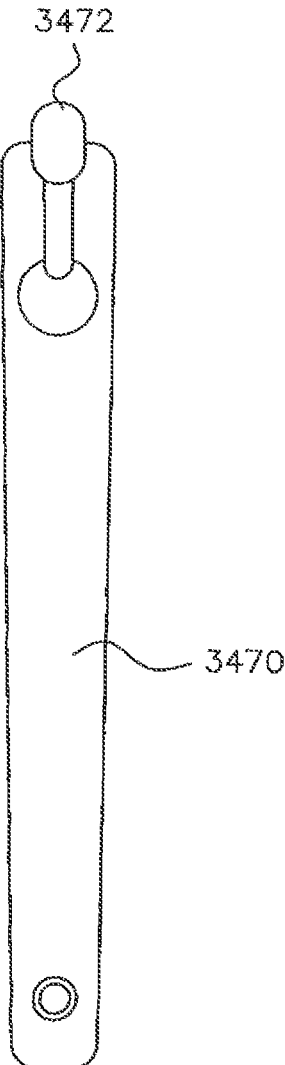
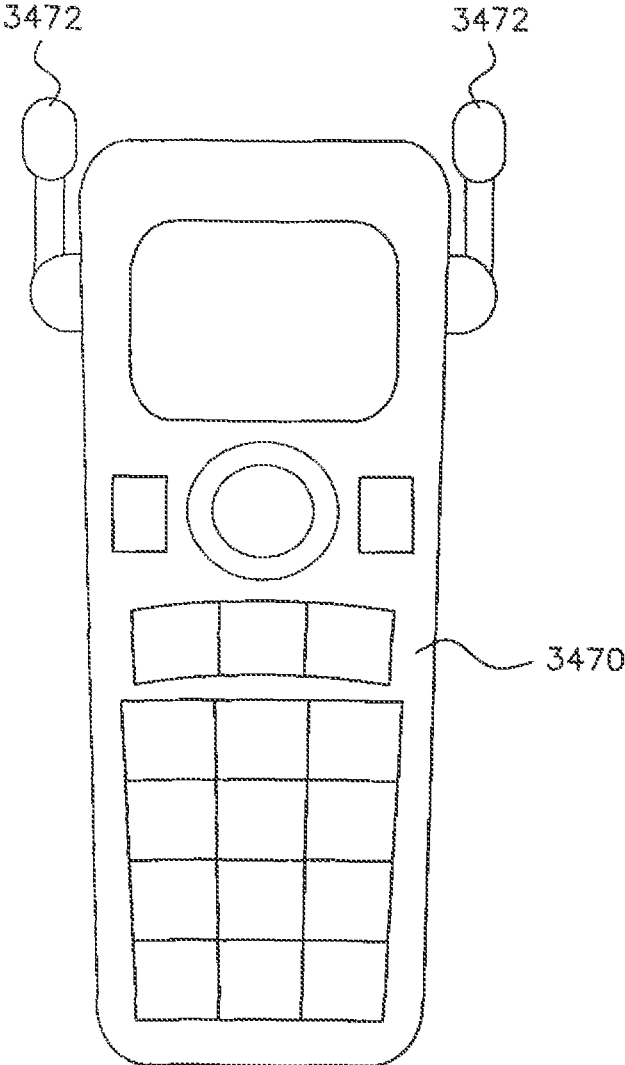

FIG. 124A

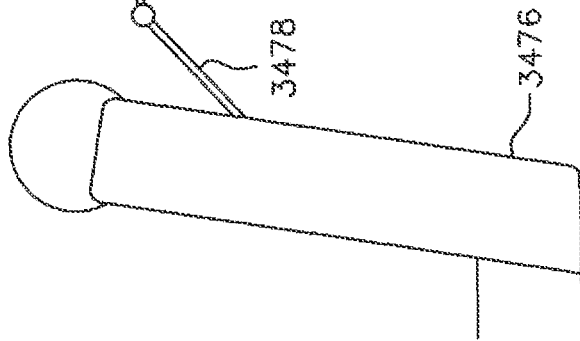

FIG. 124B

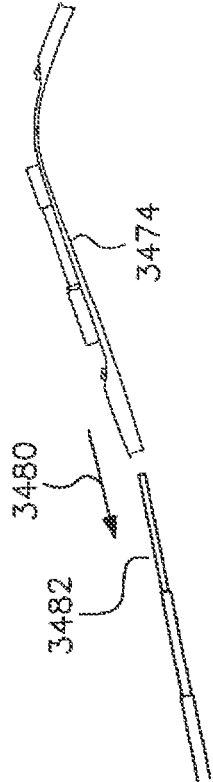

FIG. 124C

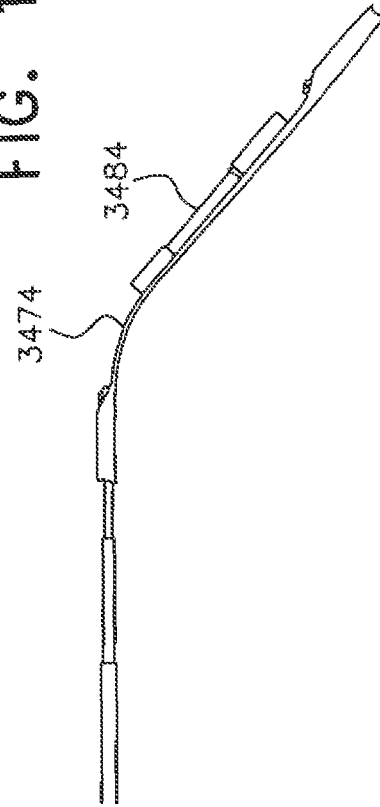

FIG. 125

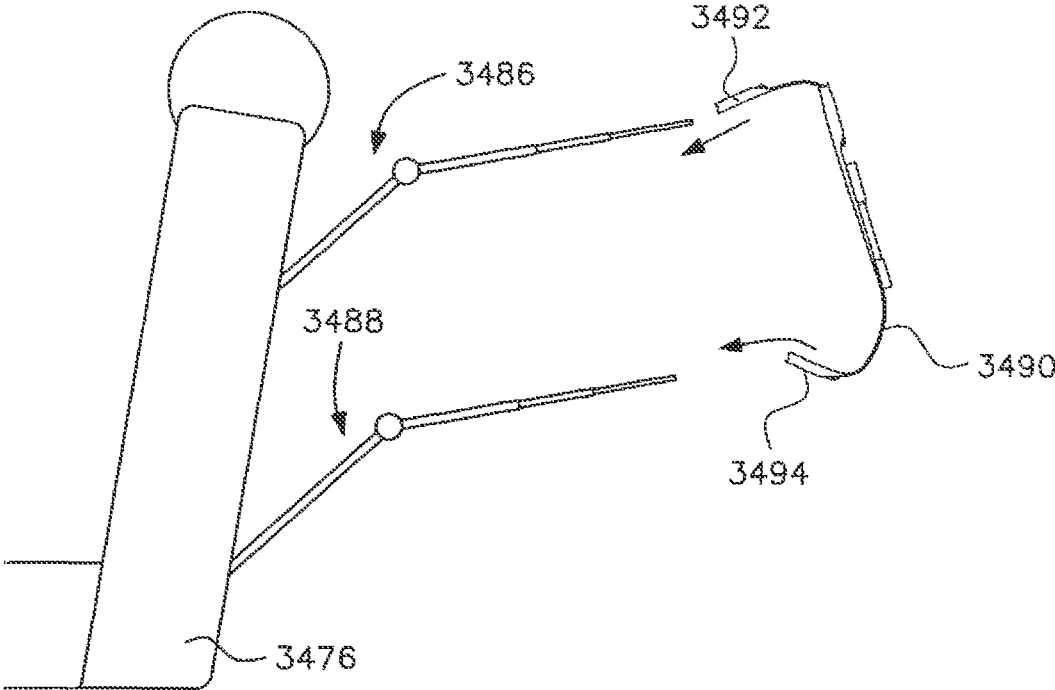

FIG. 126A

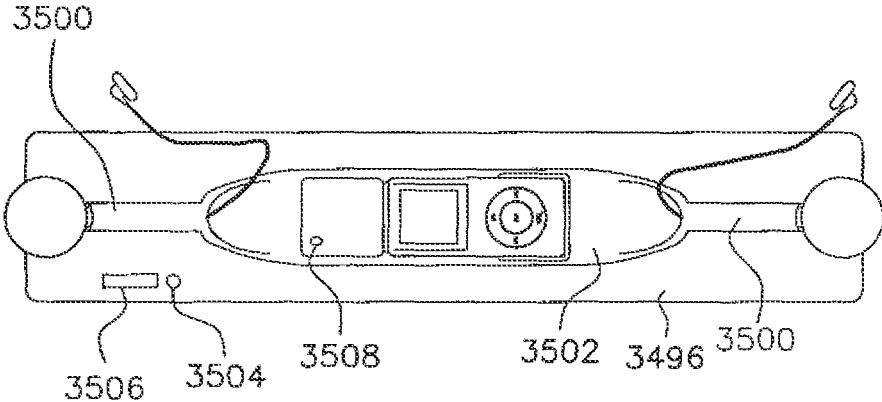

FIG. 126B

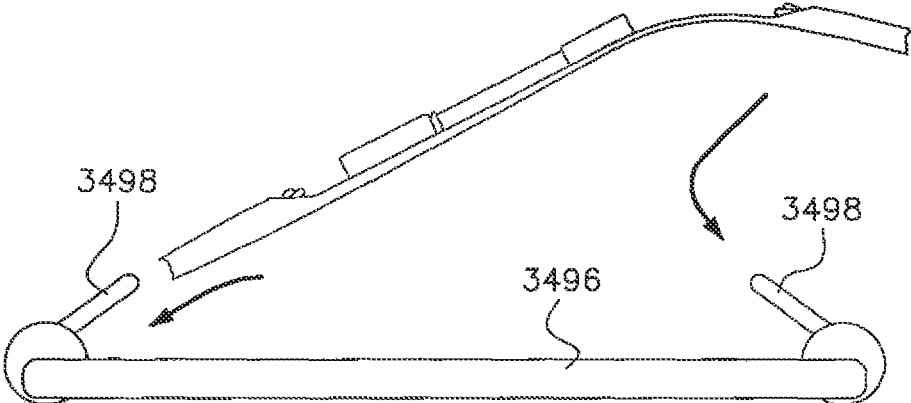

FIG. 126C

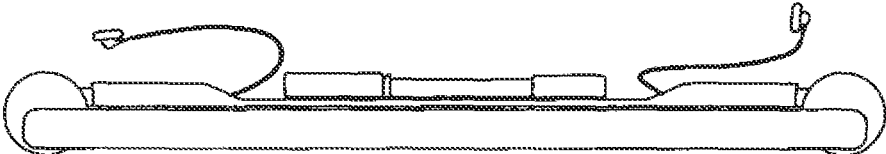

FIG. 127A

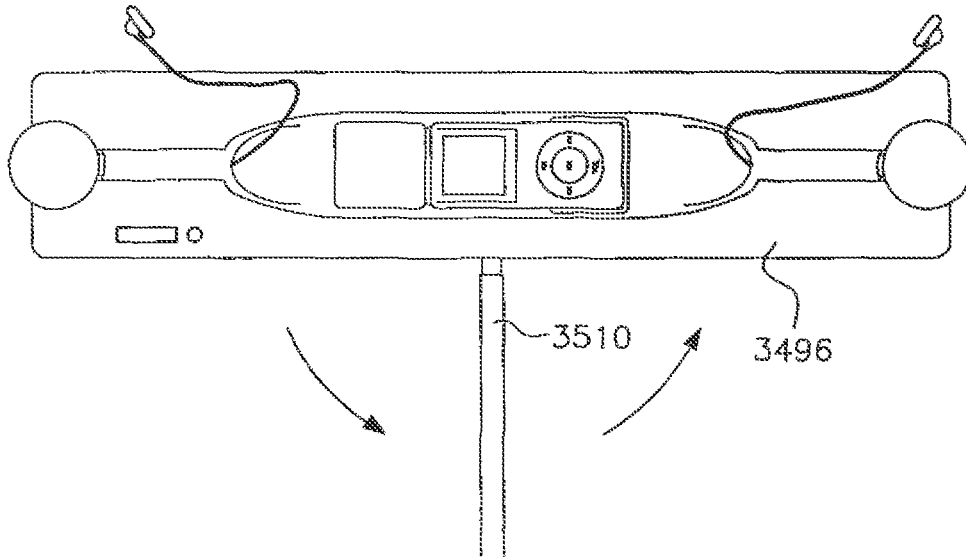

FIG. 127B

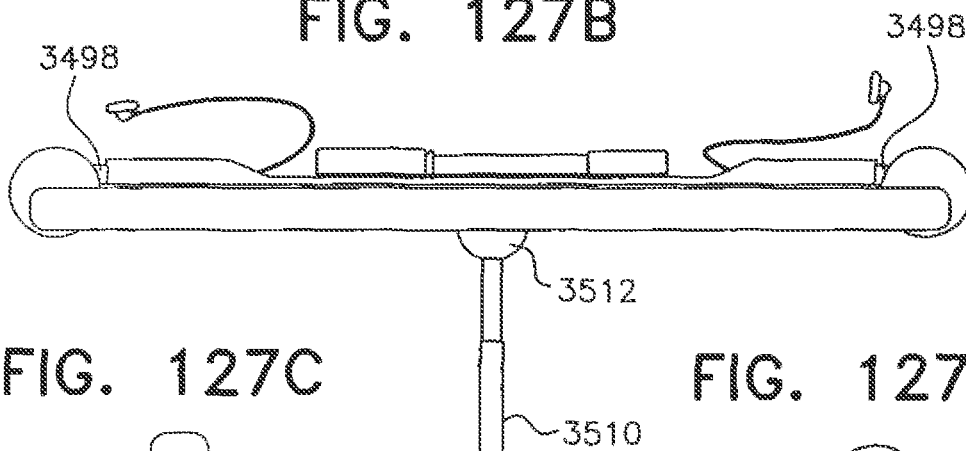

FIG. 127C

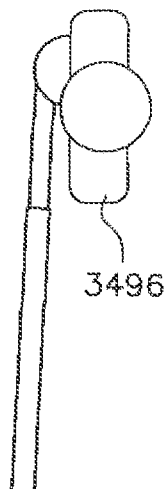

FIG. 127D

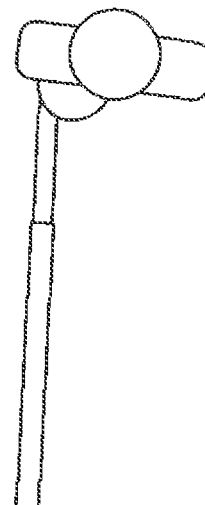

FIG. 128A

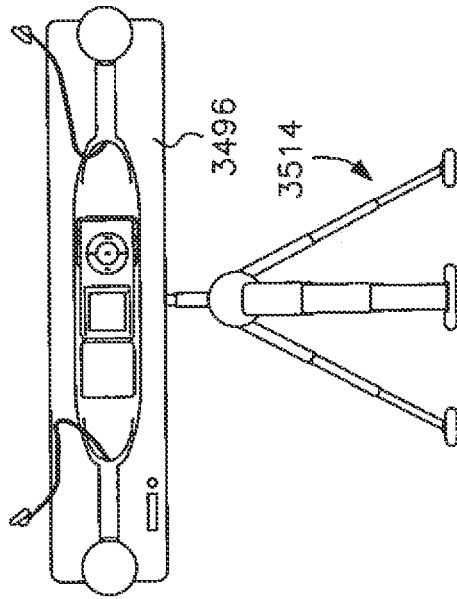

FIG. 128B

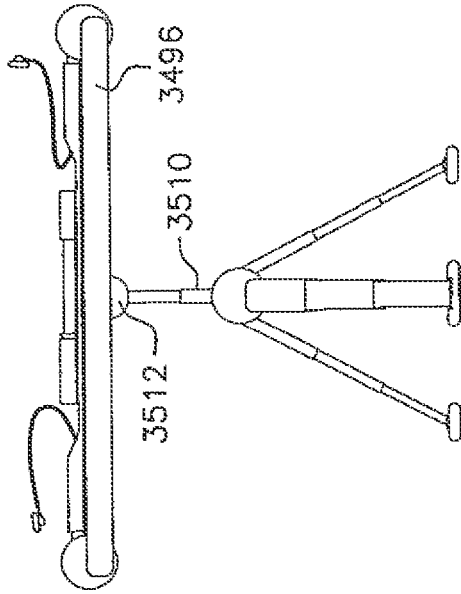

FIG. 128C

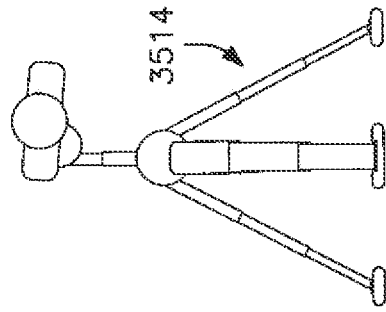

FIG. 128D

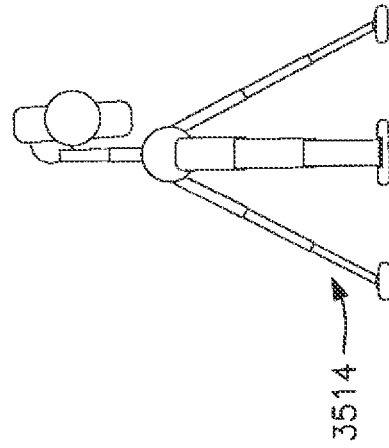

FIG. 128E

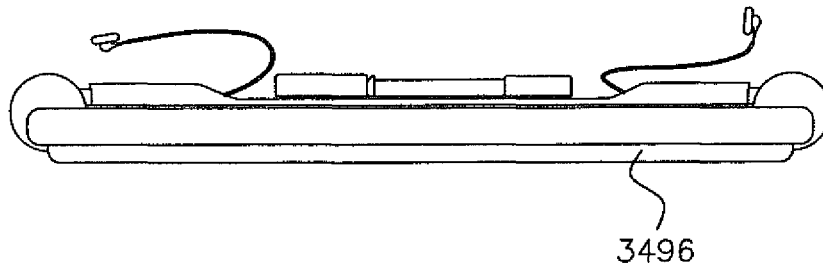

FIG. 128F

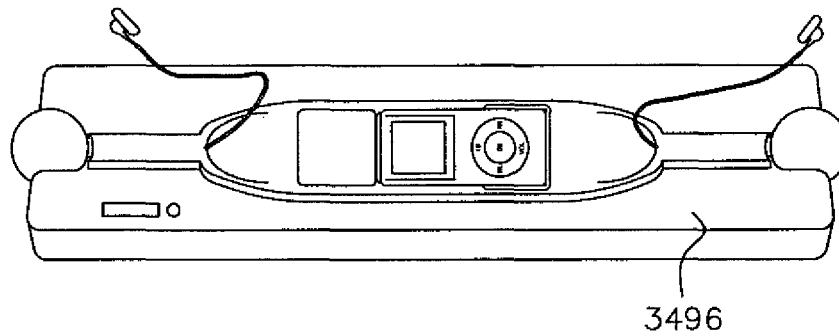

FIG. 128G

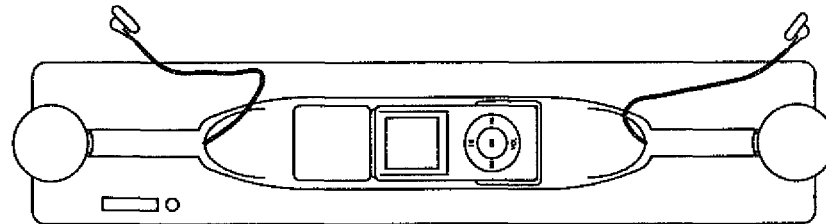

FIG. 128H

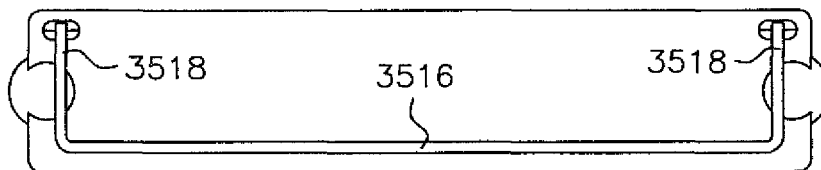

FIG. 128I



FIG. 128J

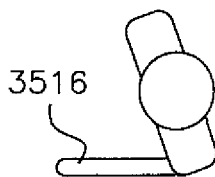

FIG. 128K

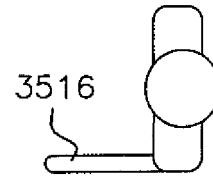

FIG. 129A

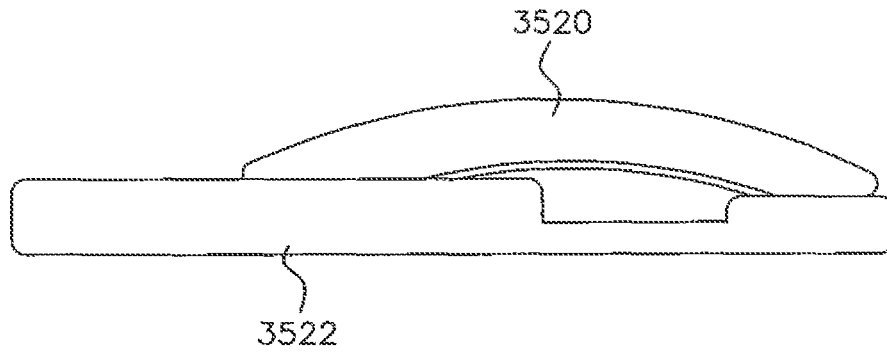

FIG. 129B

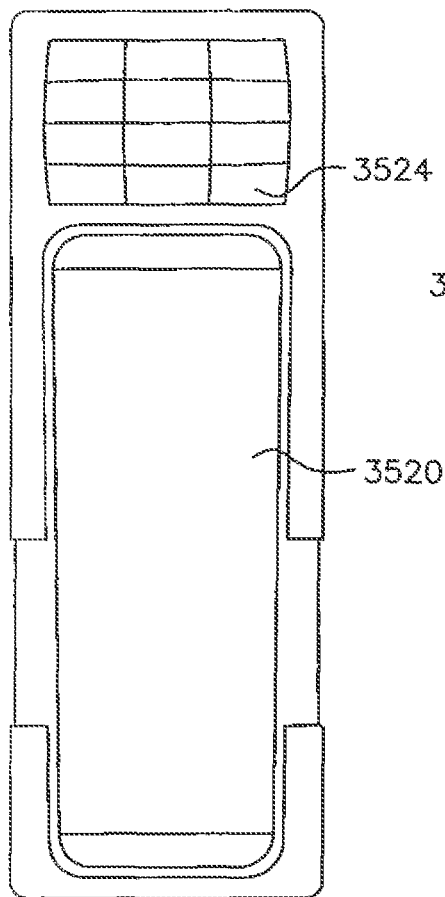

FIG. 129C

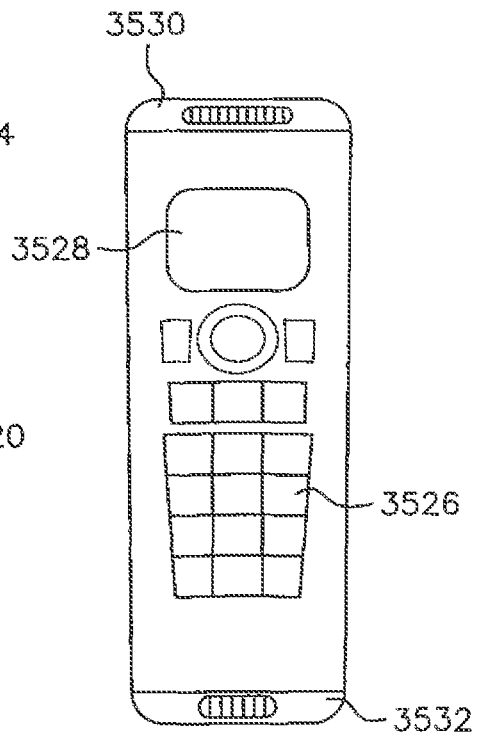

FIG. 130

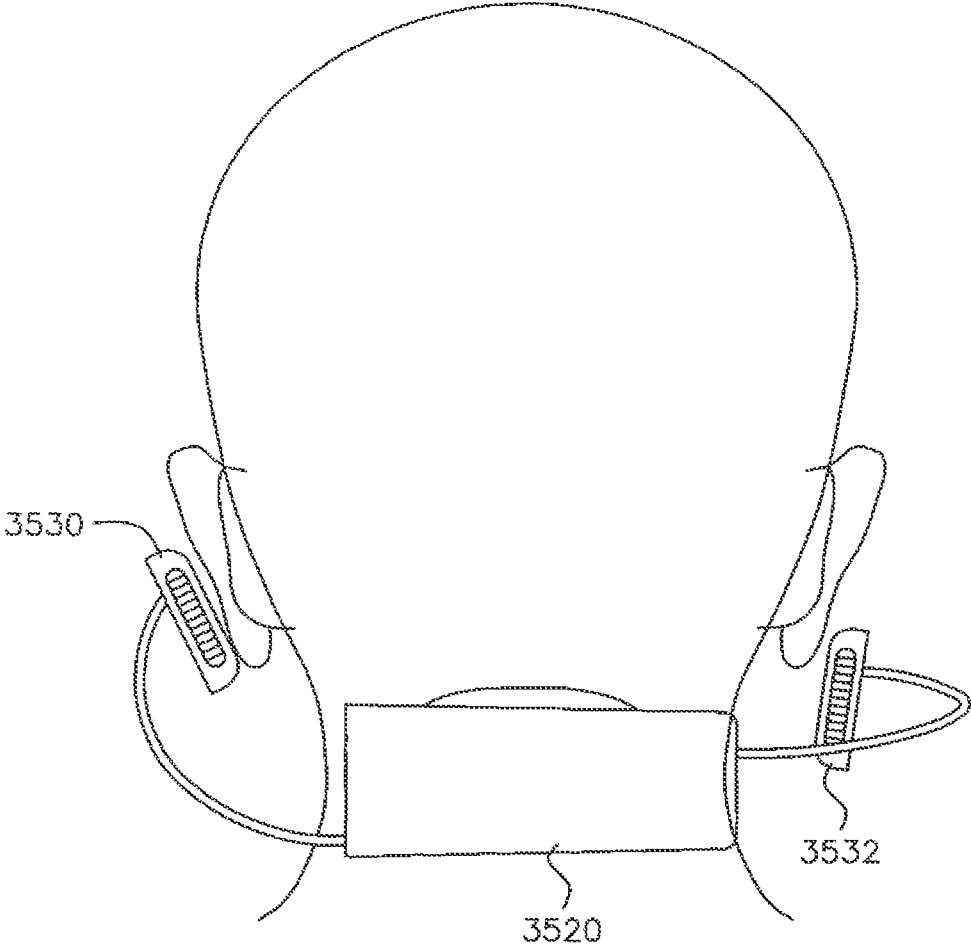

FIG. 131

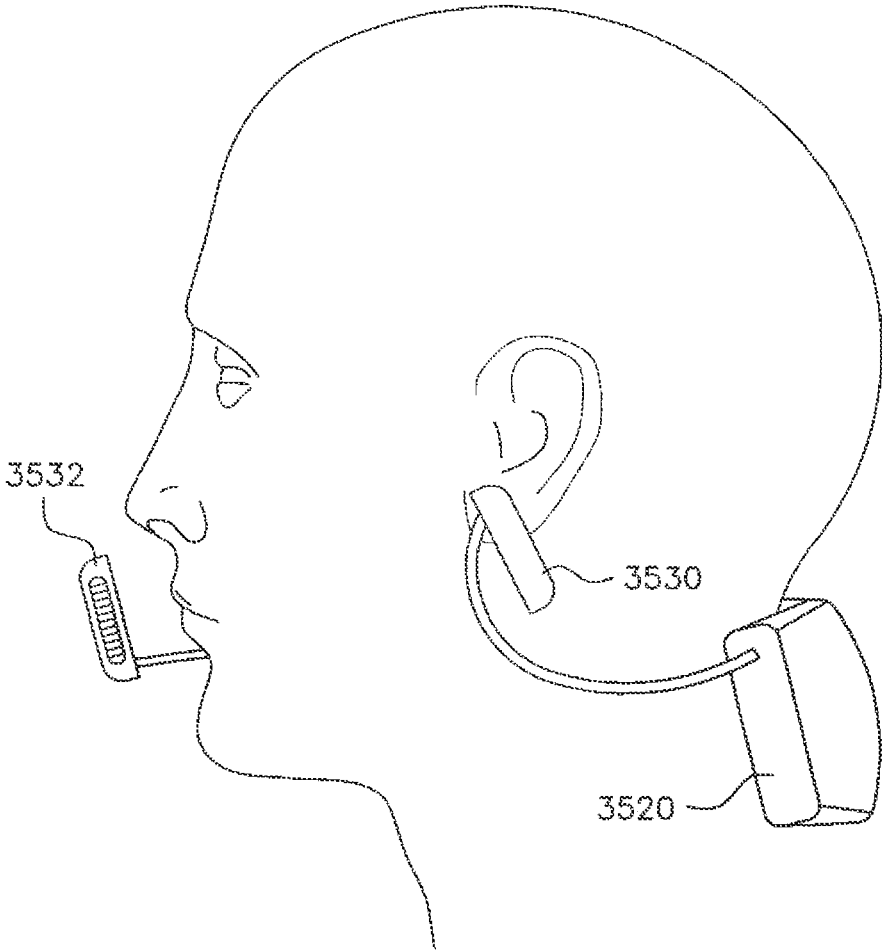

FIG. 132A

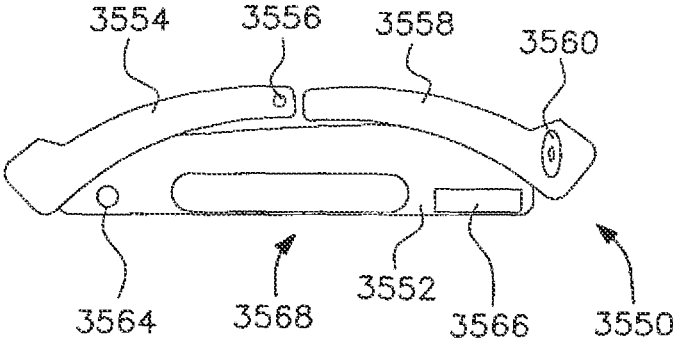

FIG. 132B

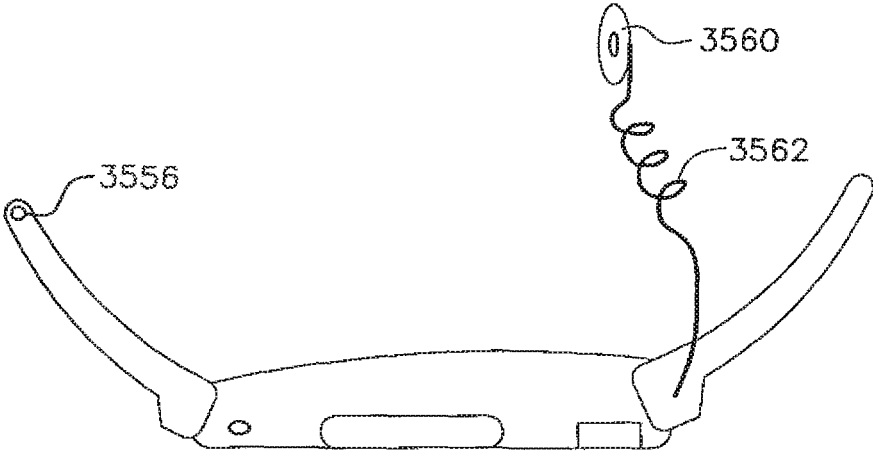

FIG. 133

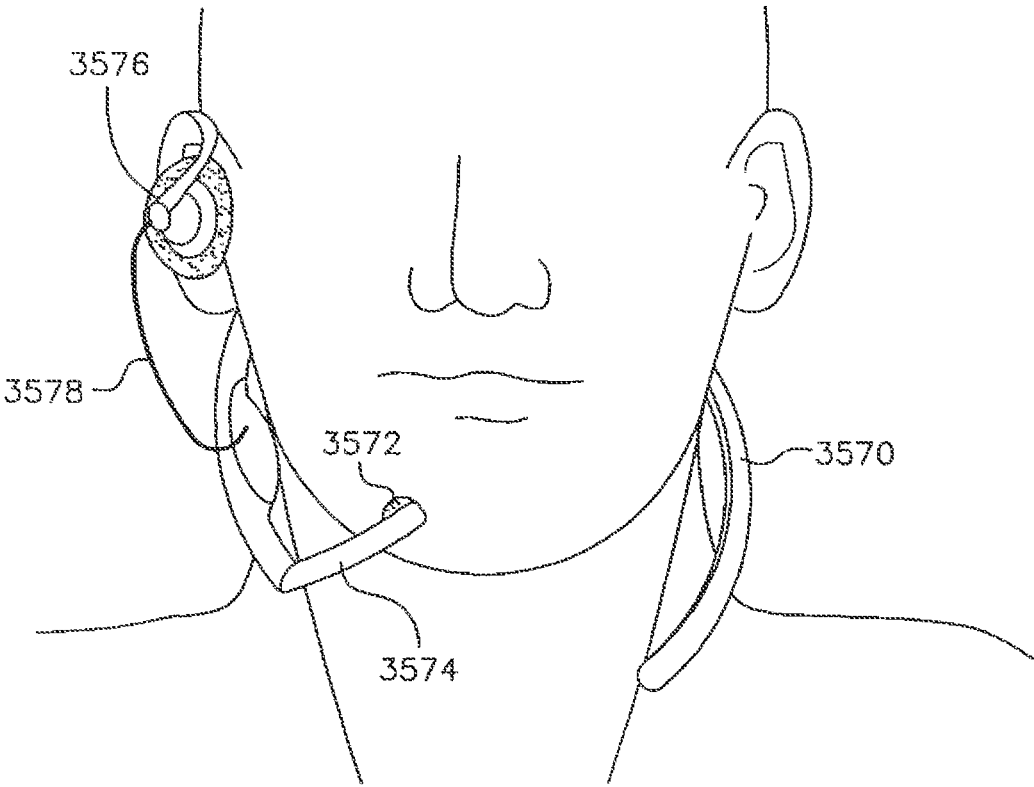

FIG. 134

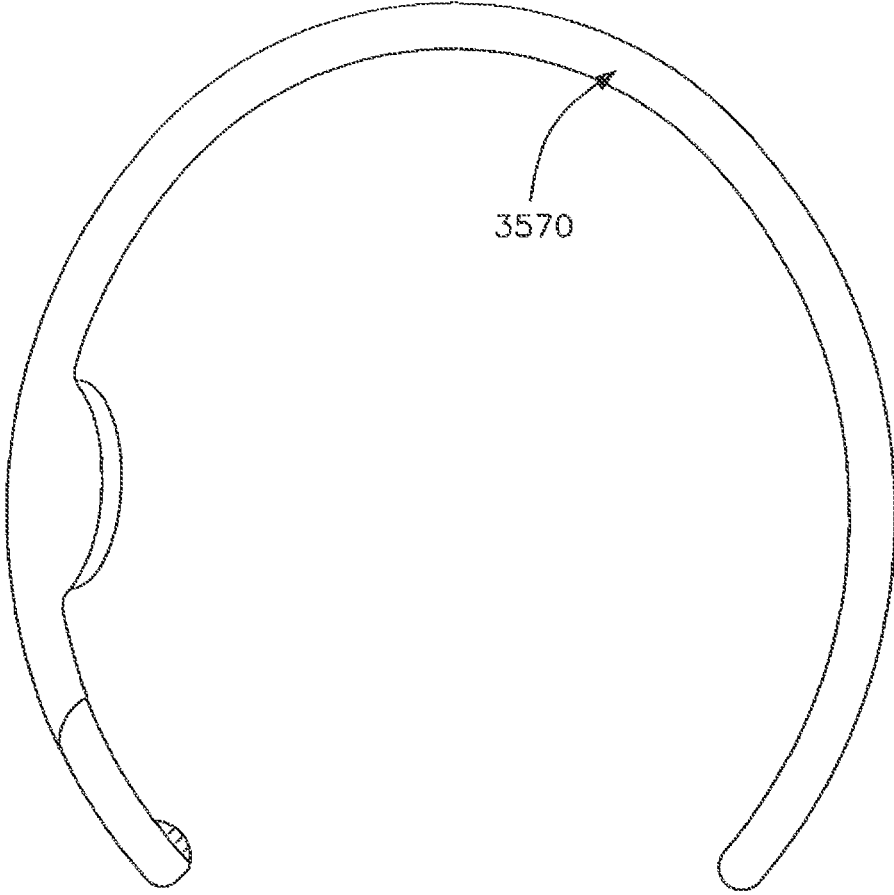

FIG. 135

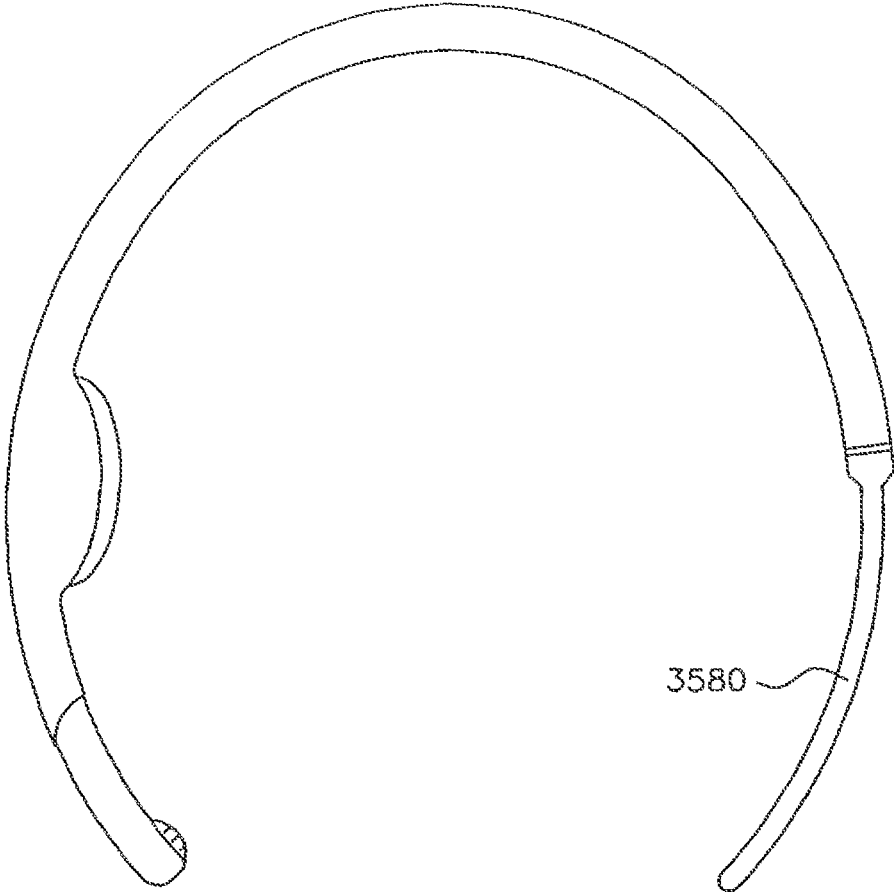

FIG. 136A

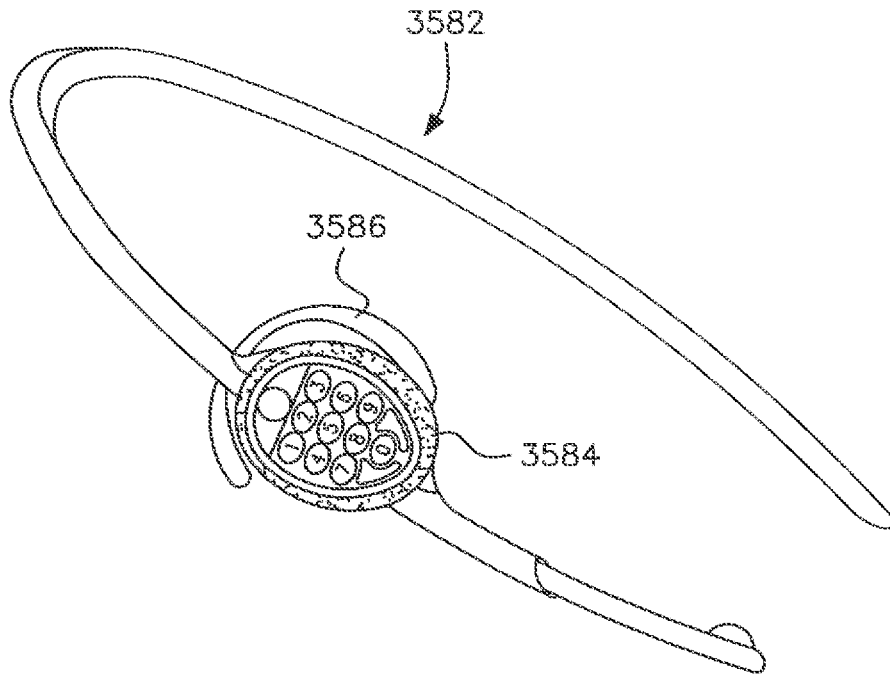

FIG. 136B

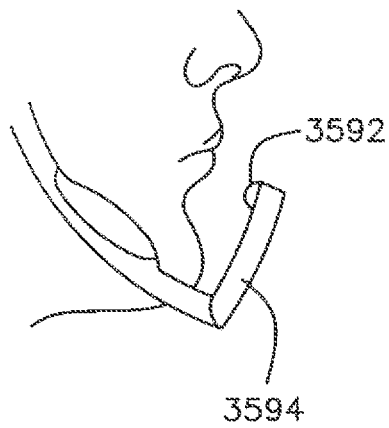

FIG. 136C

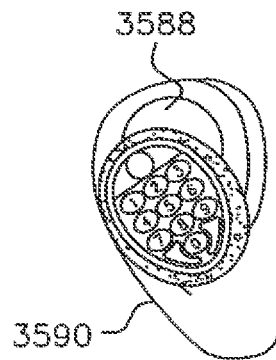

FIG. 137

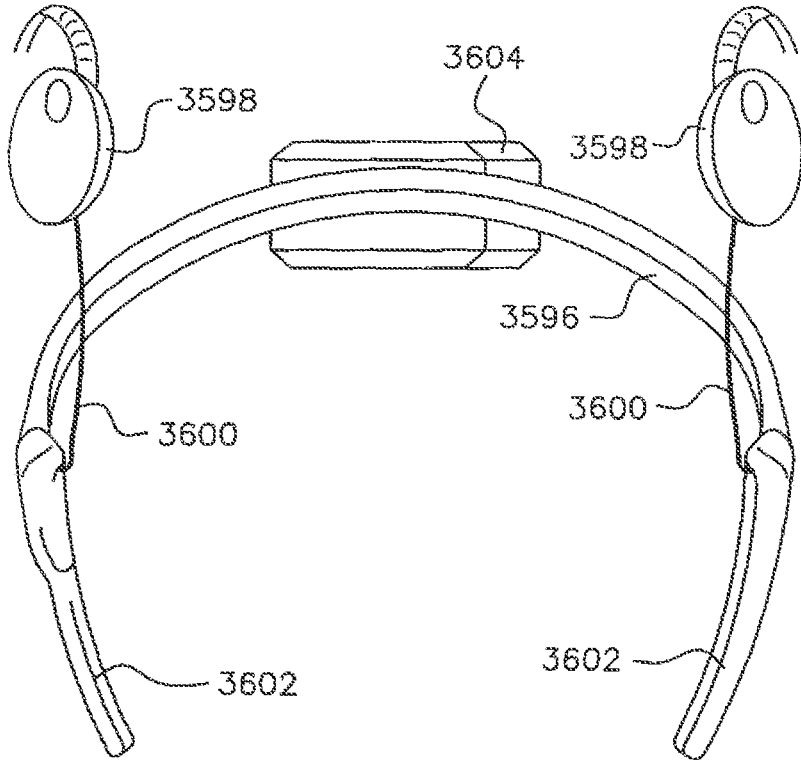

FIG. 138

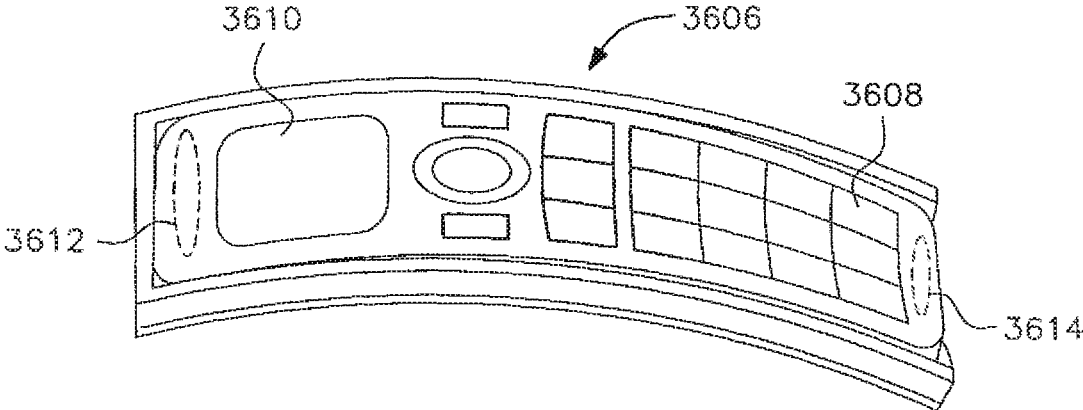

FIG. 139

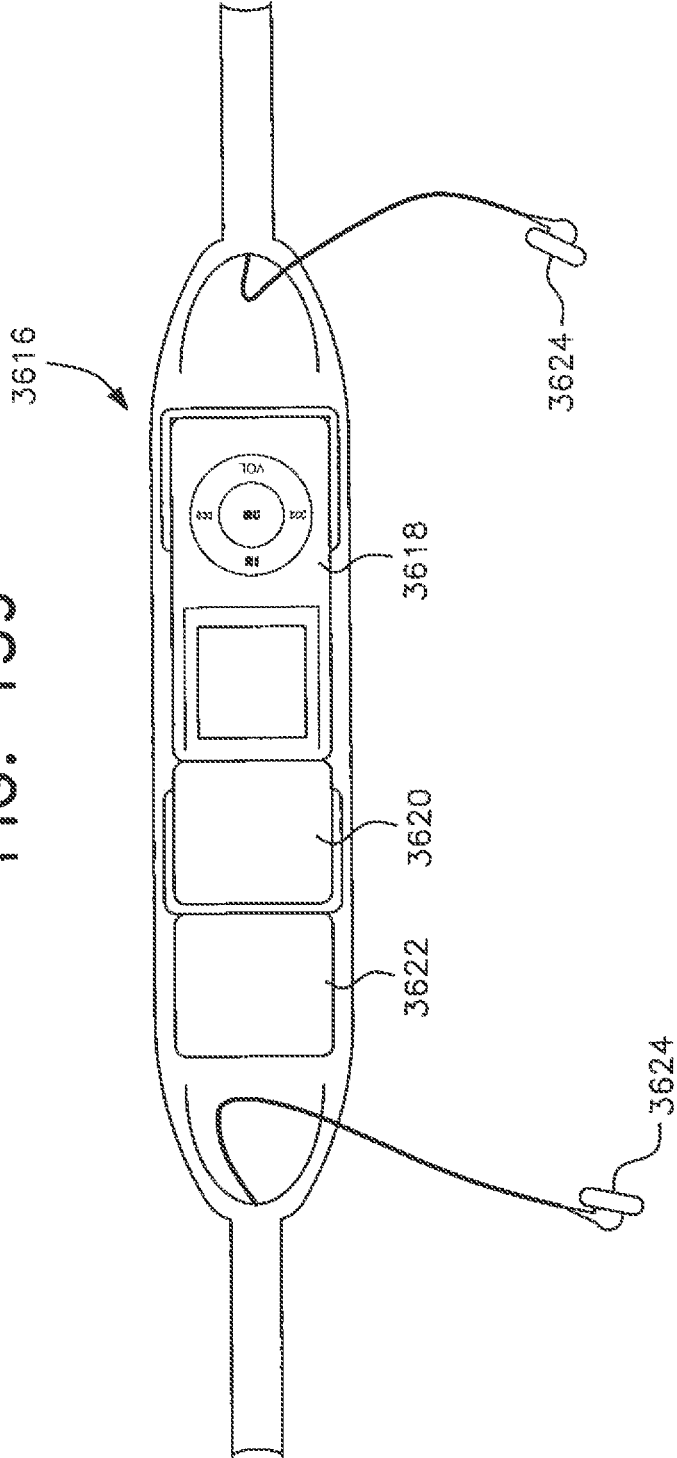

FIG. 140

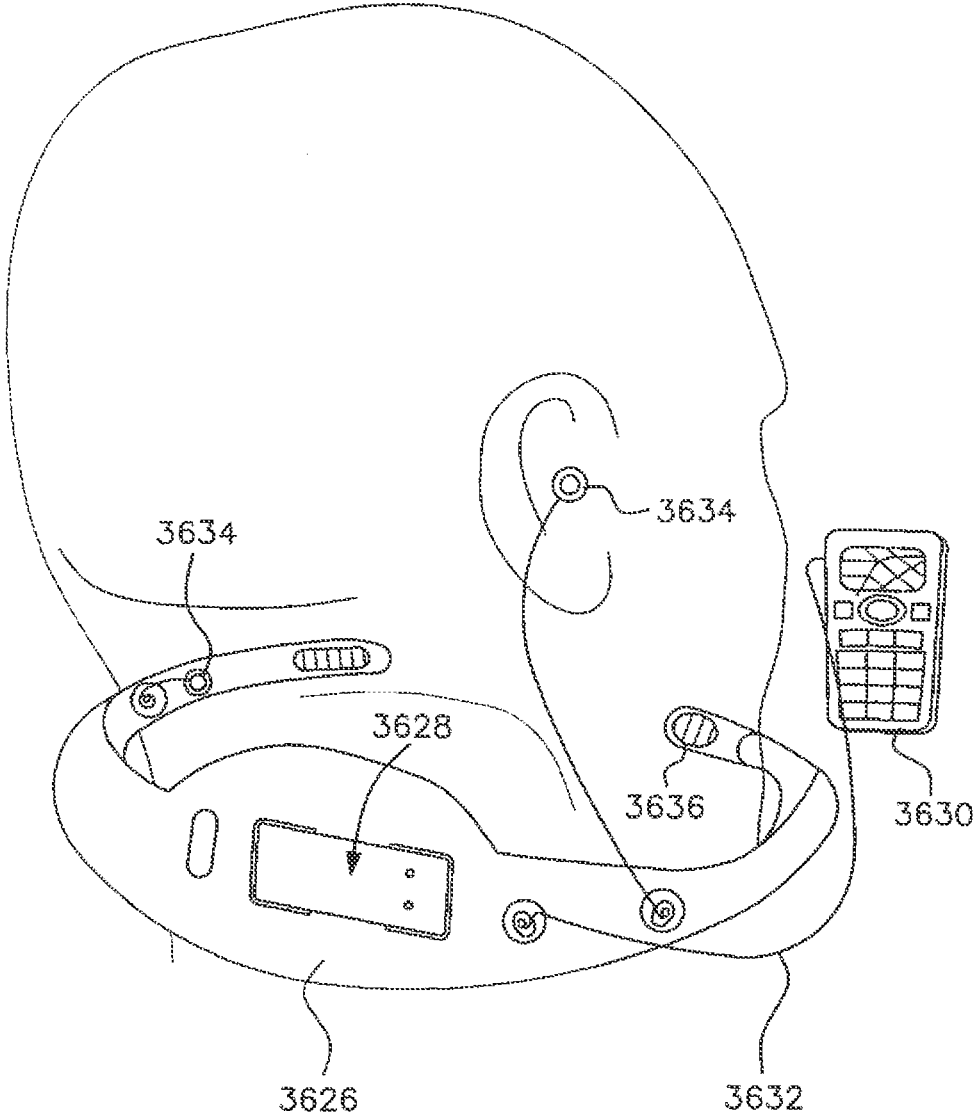

FIG. 141

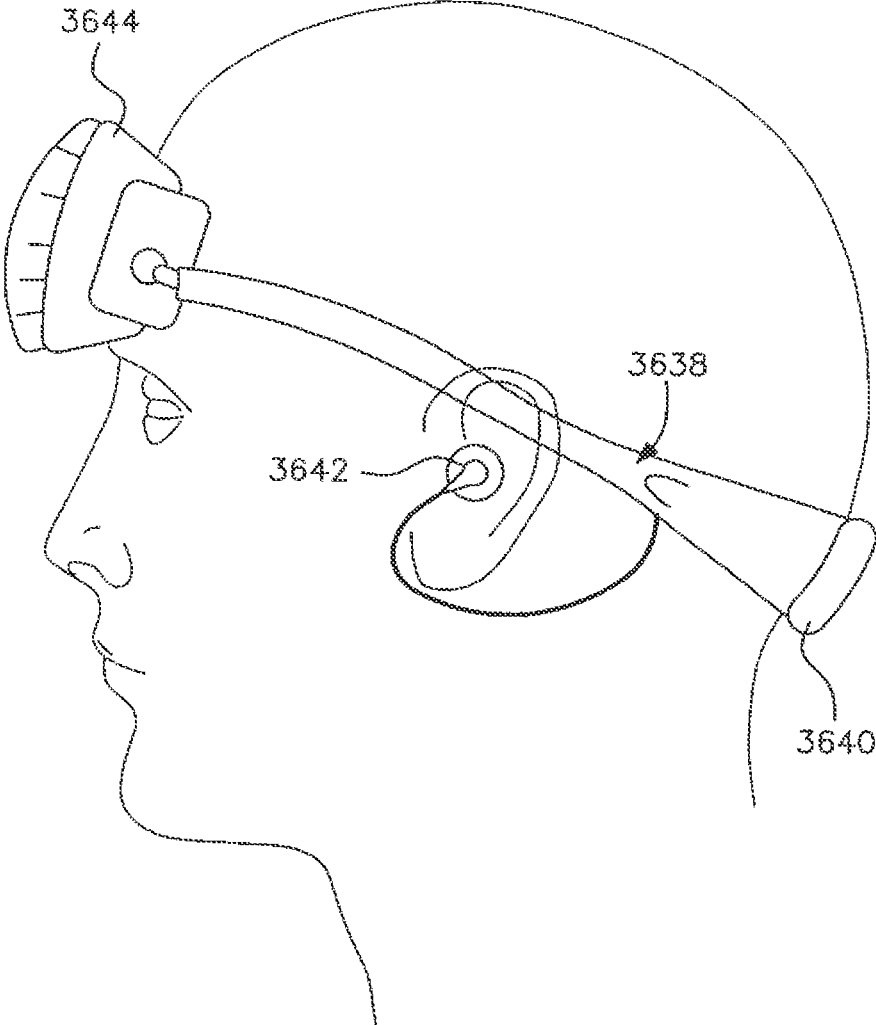

FIG. 142

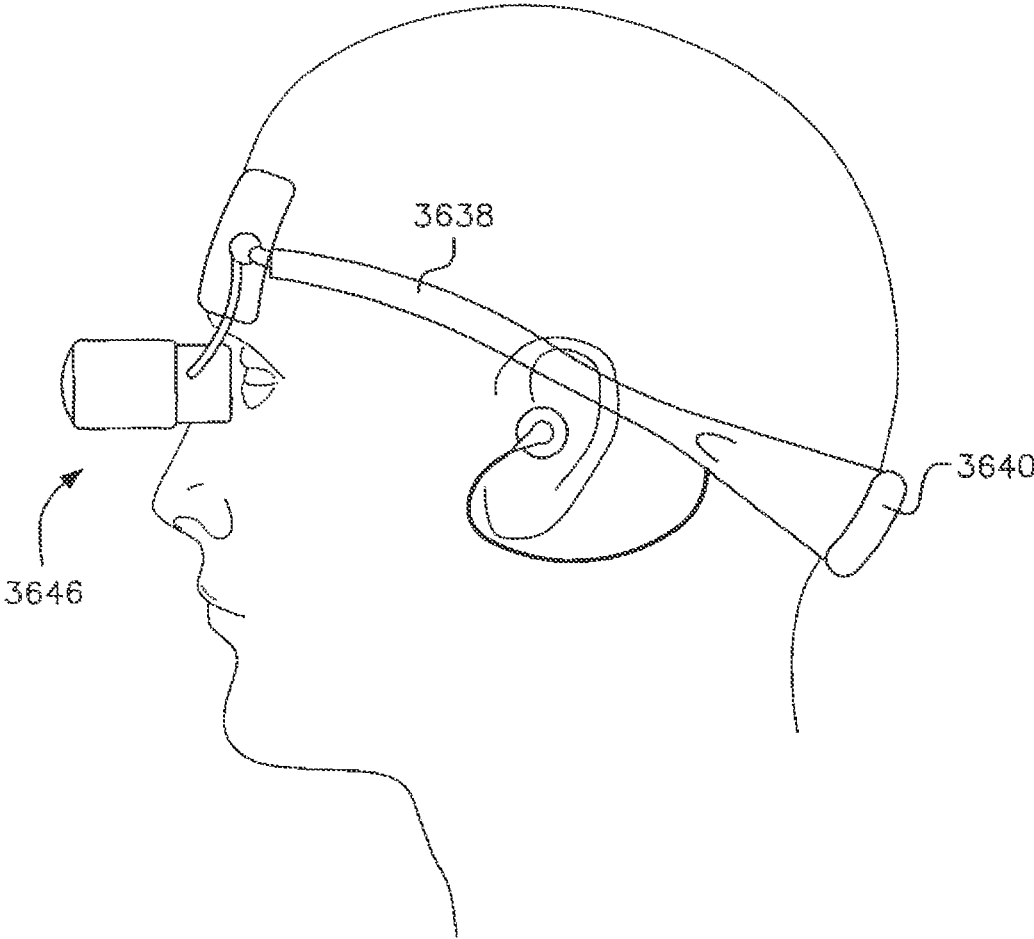

FIG. 143

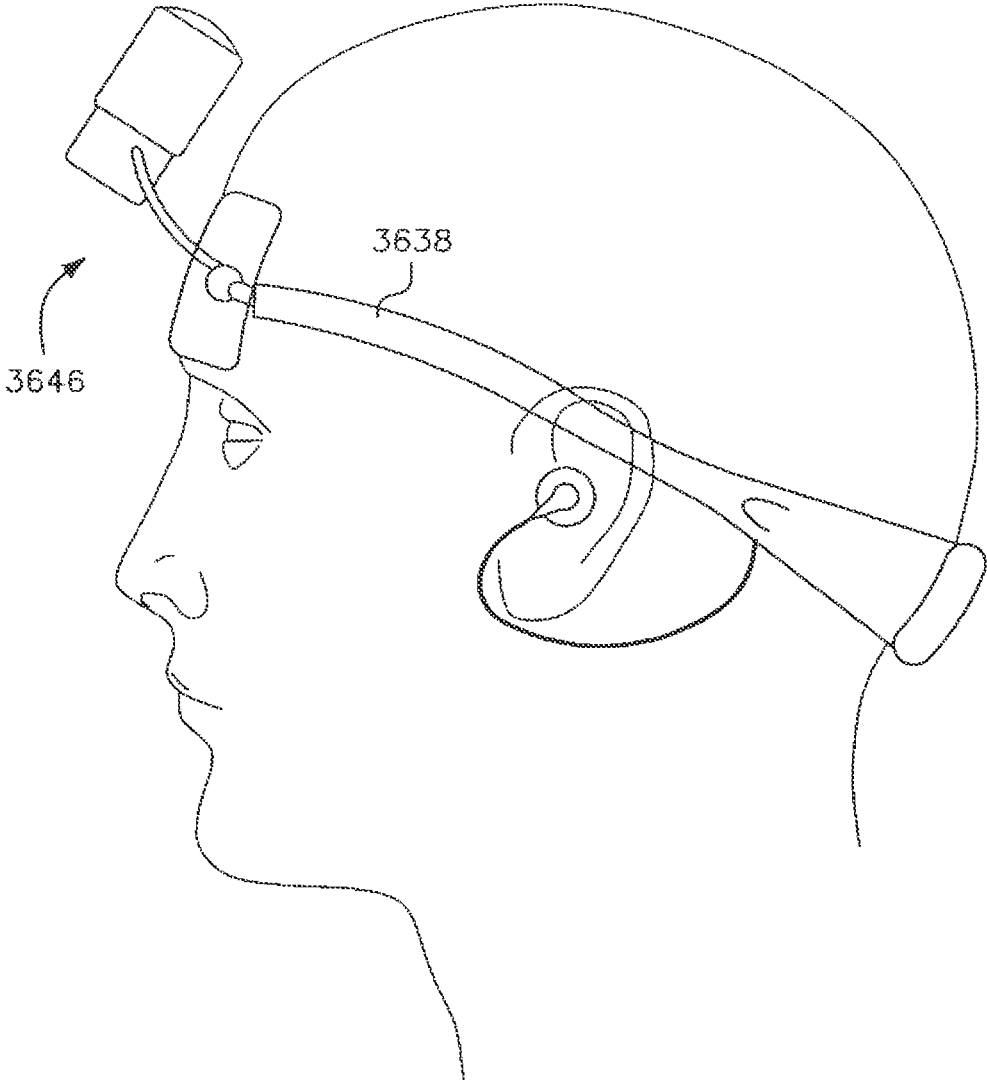

FIG. 144

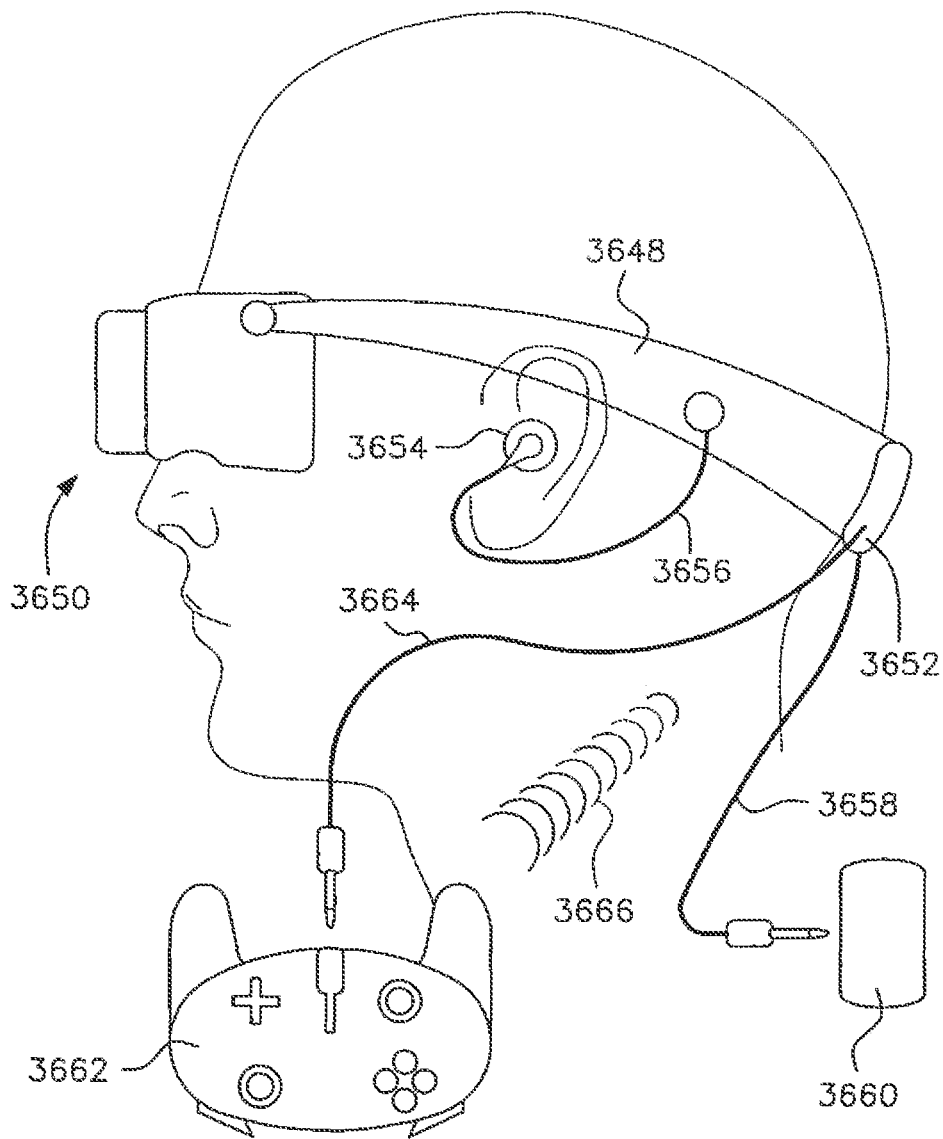

FIG. 145

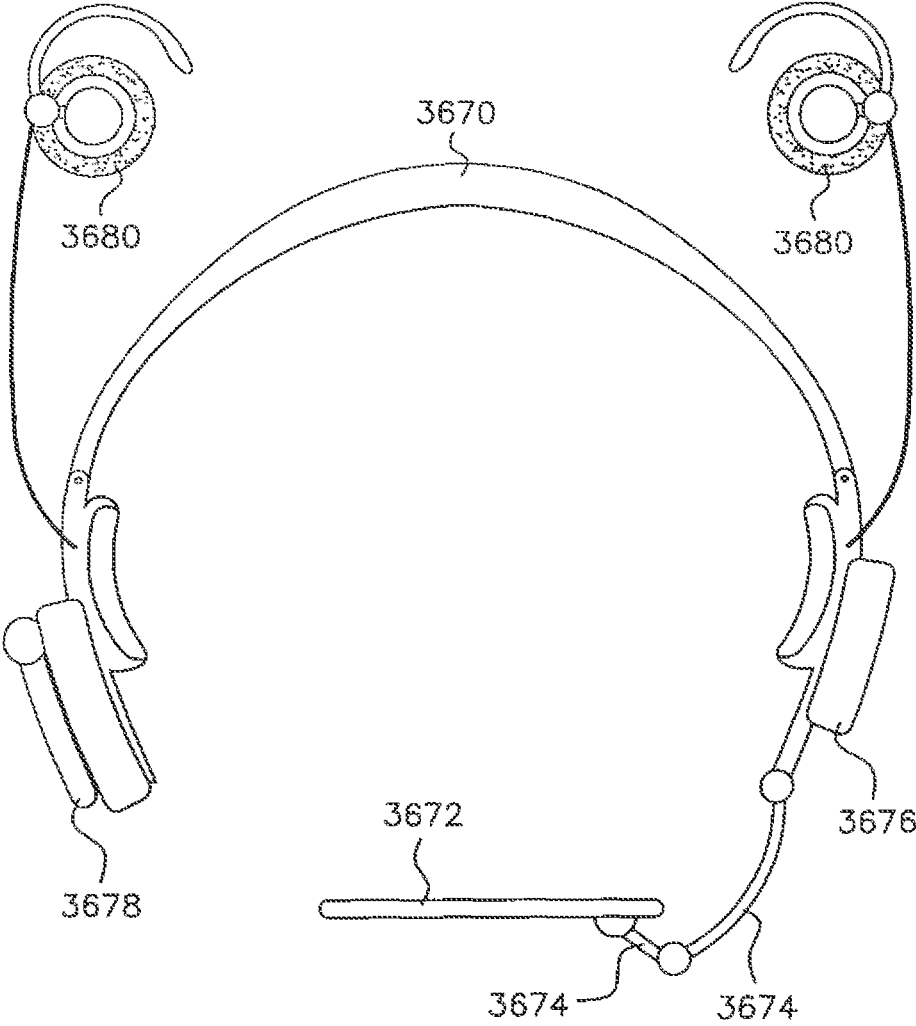

FIG. 146A

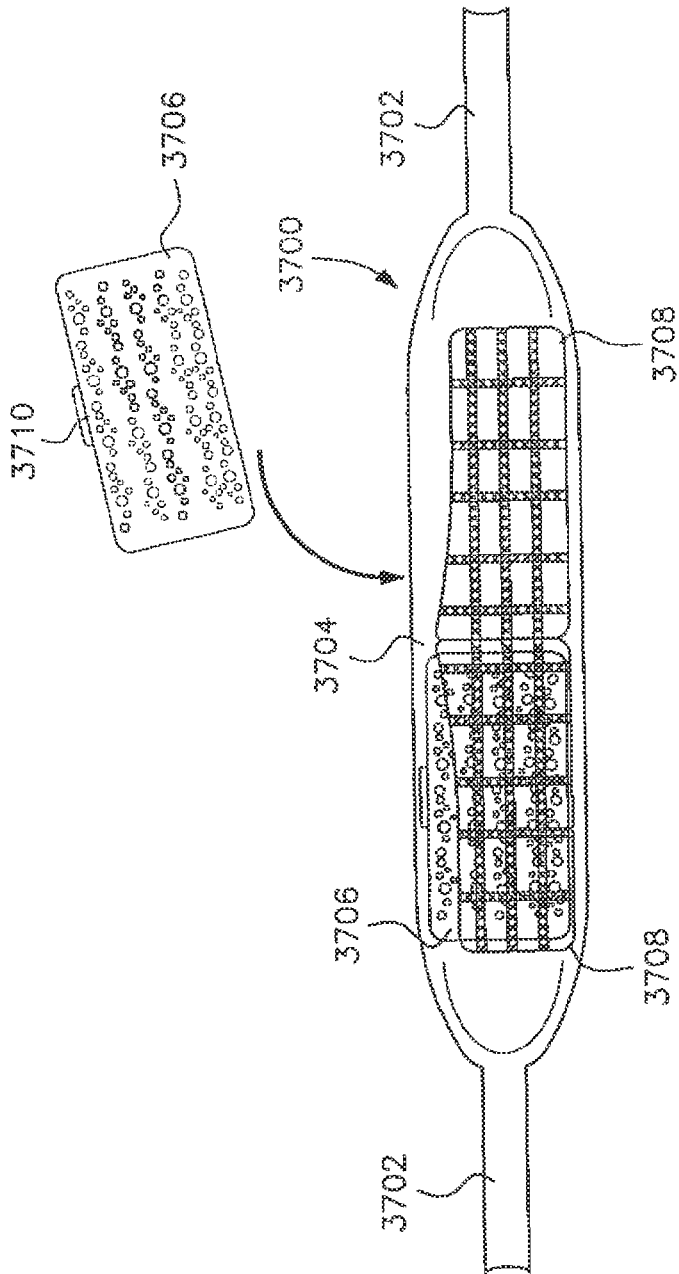

FIG. 146B

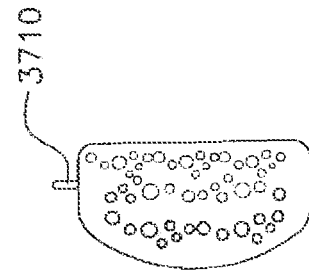

FIG. 147

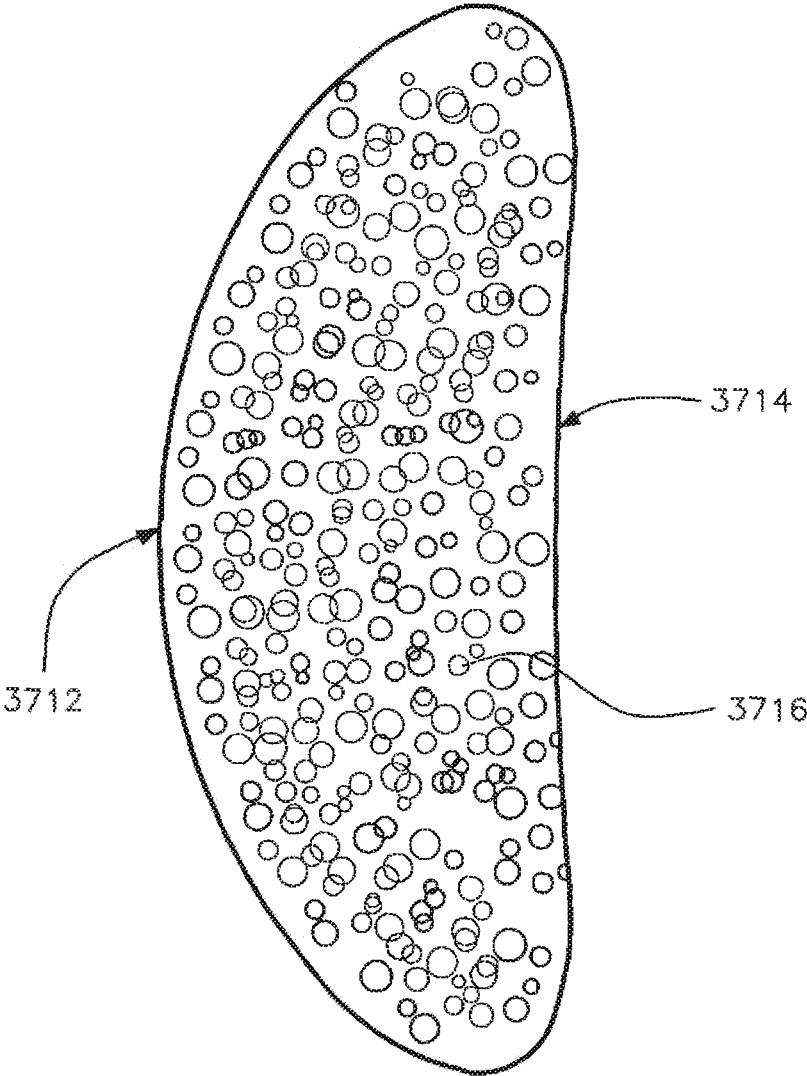

FIG. 148

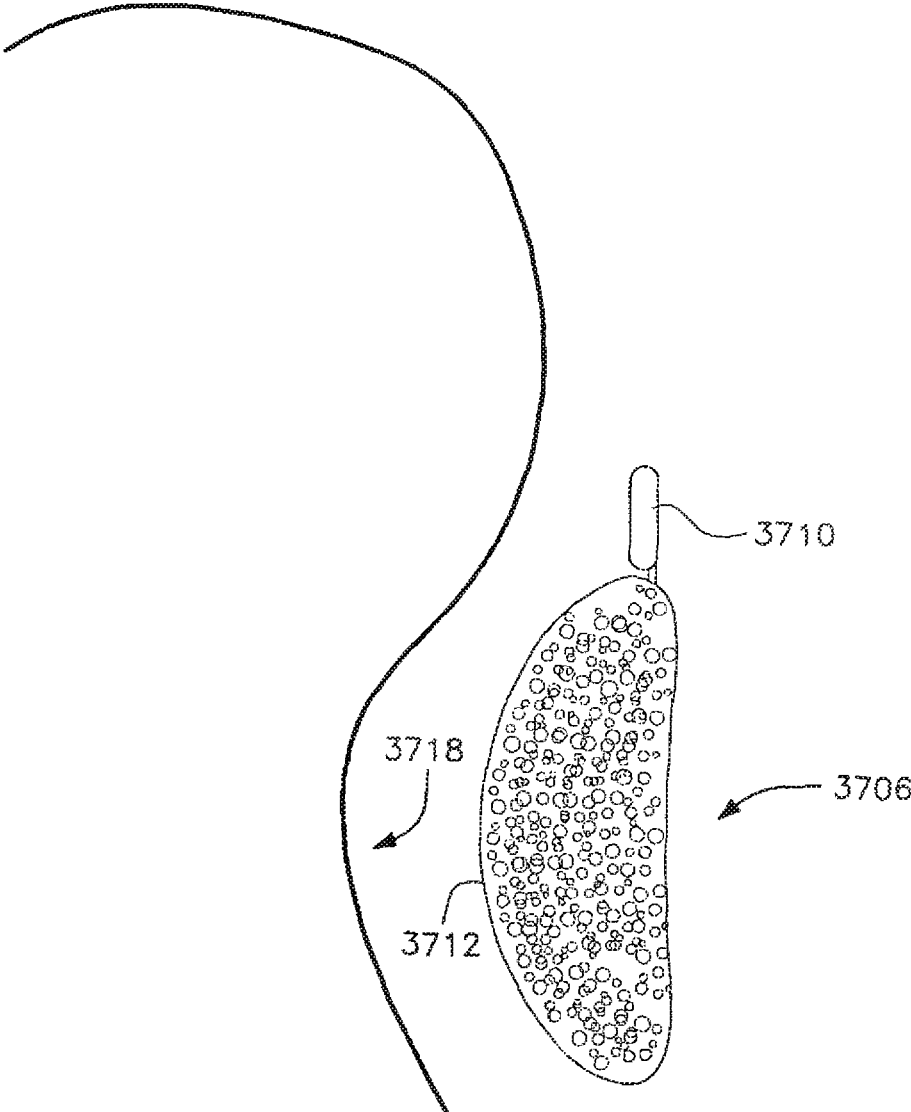

FIG. 149

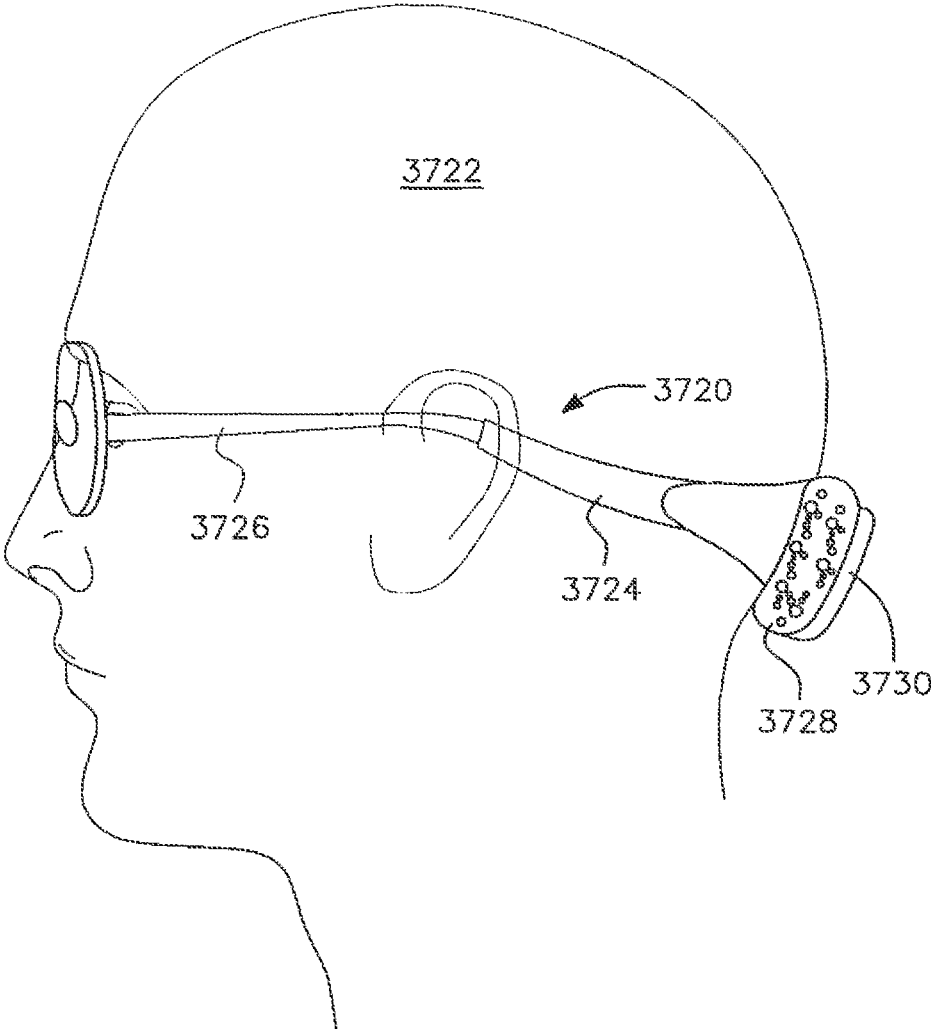

FIG. 150

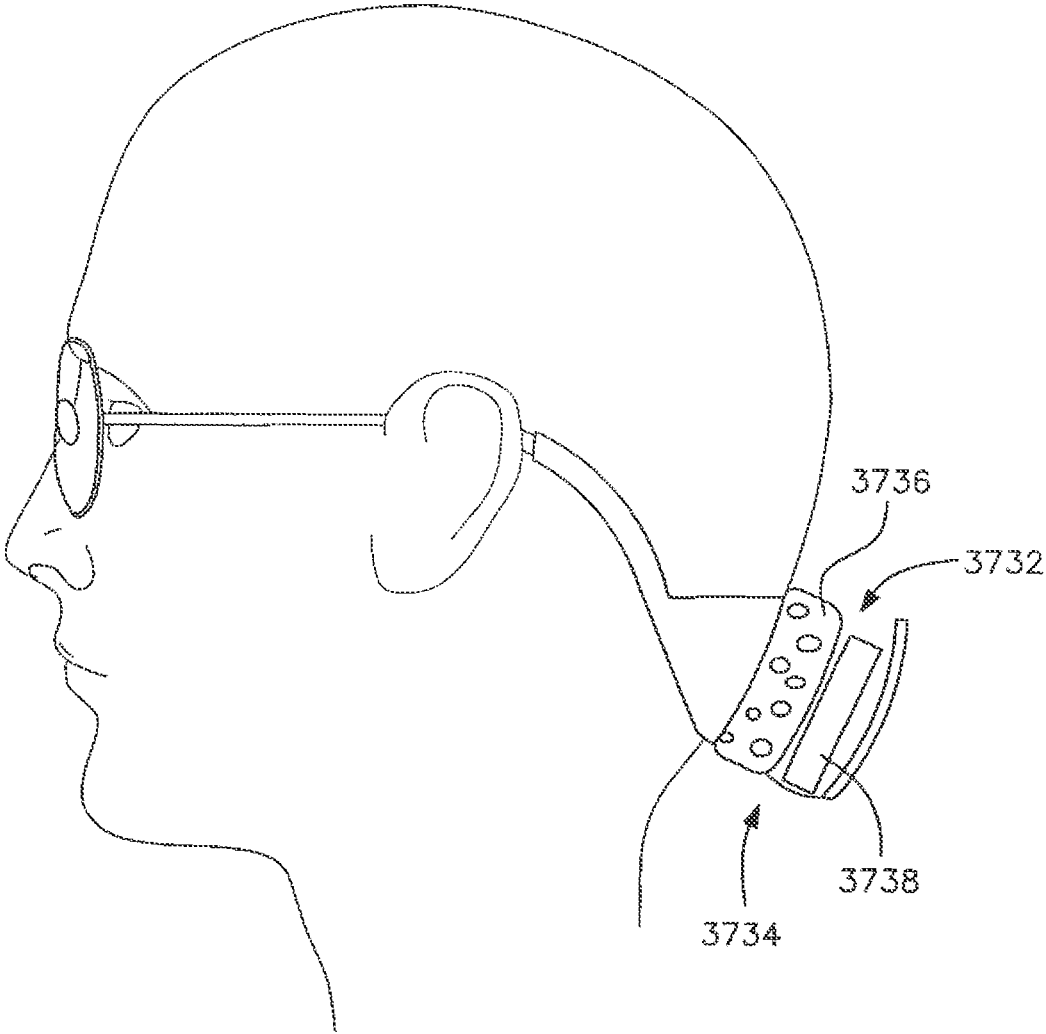

FIG. 151

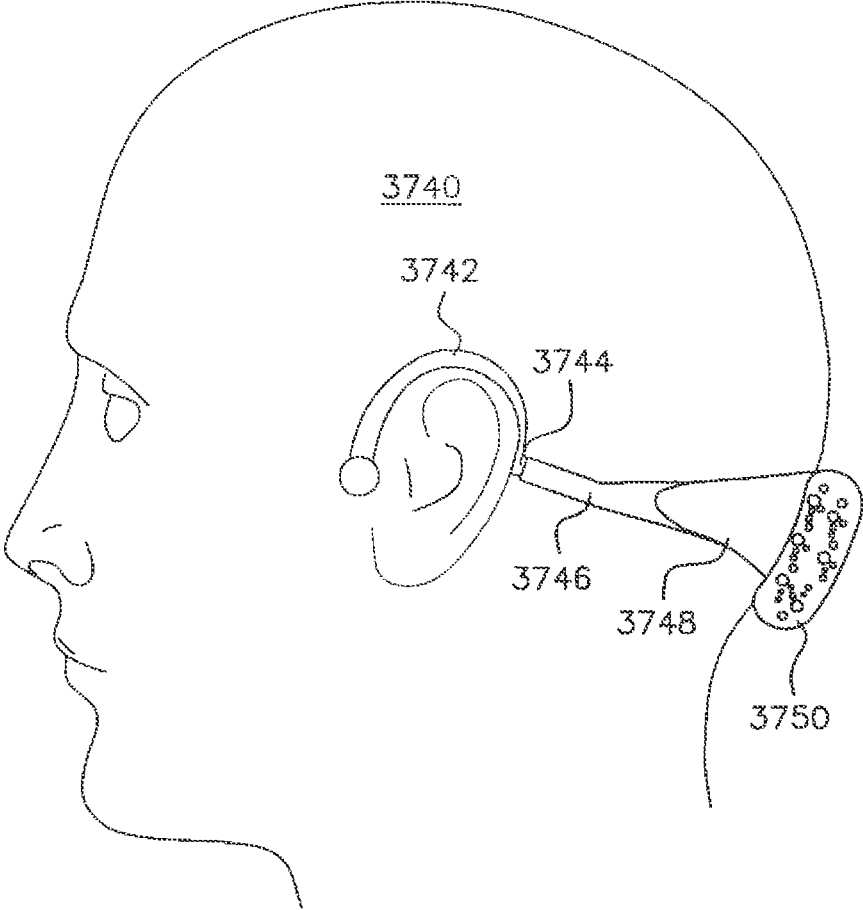

FIG. 152

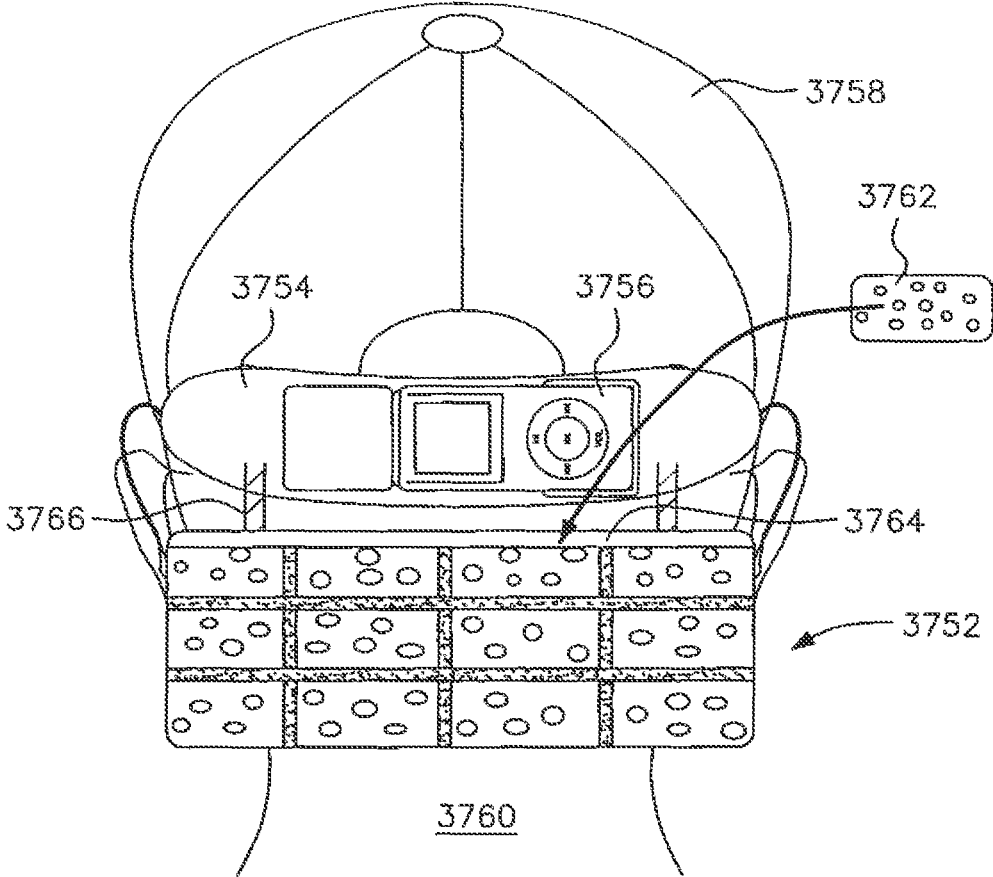

FIG. 153

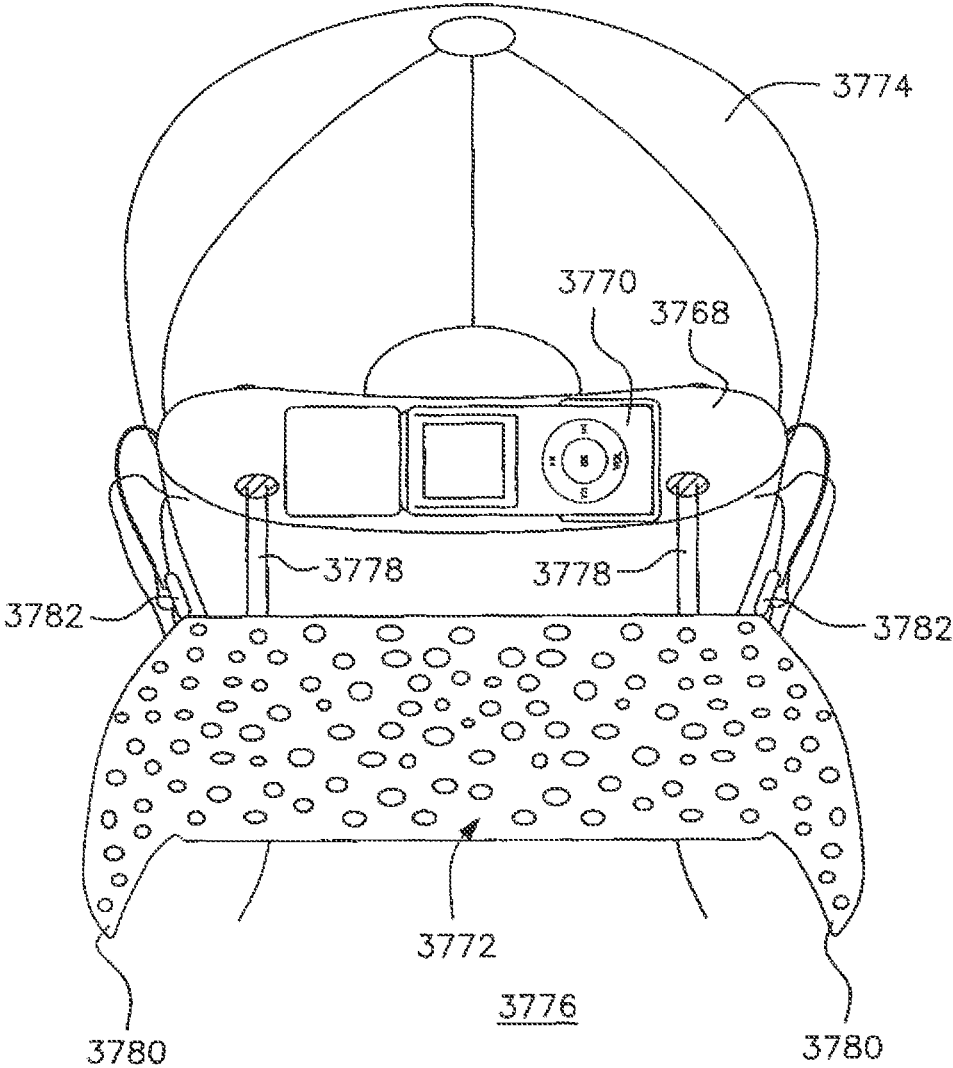

FIG. 154

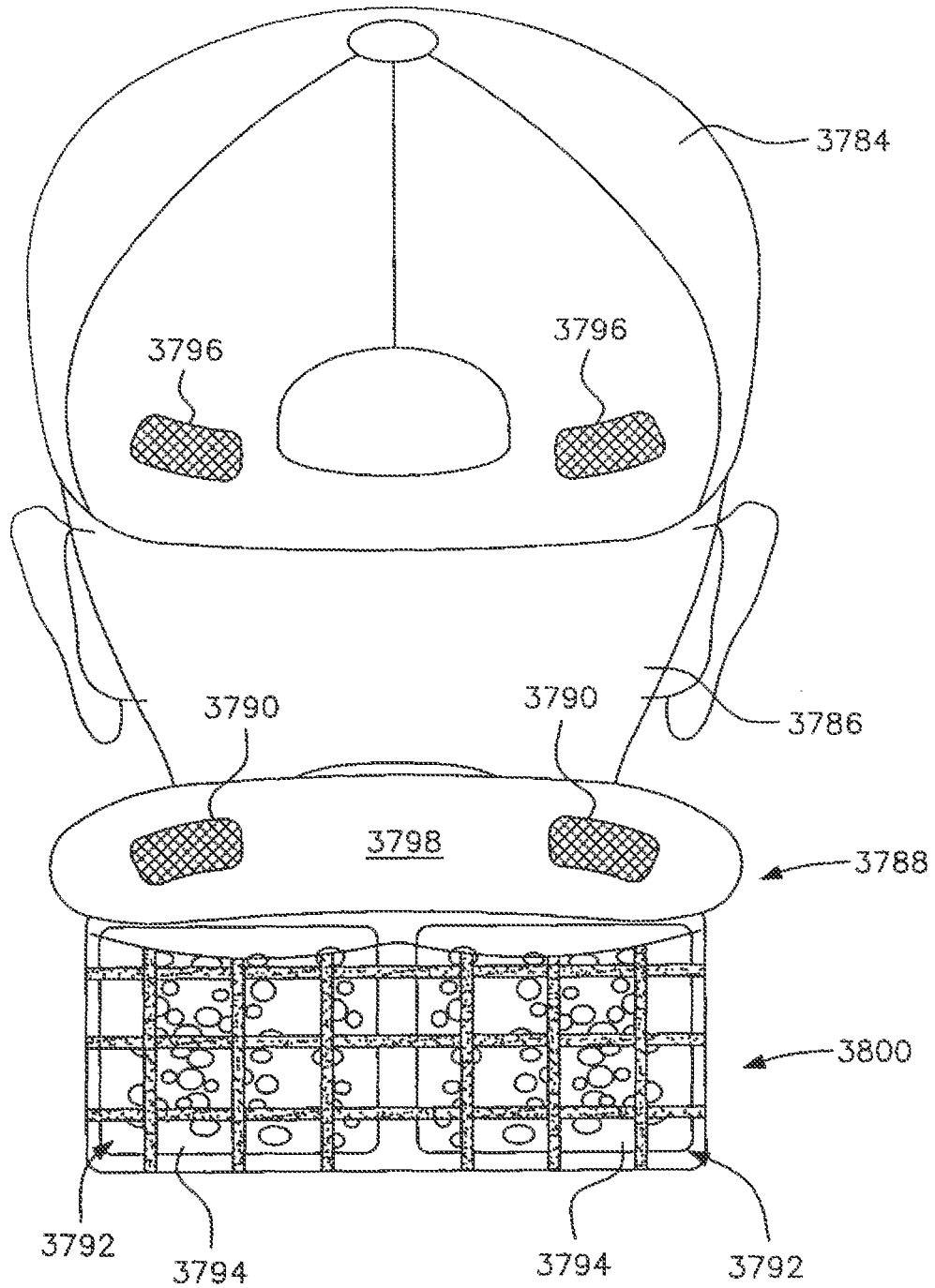

FIG. 155

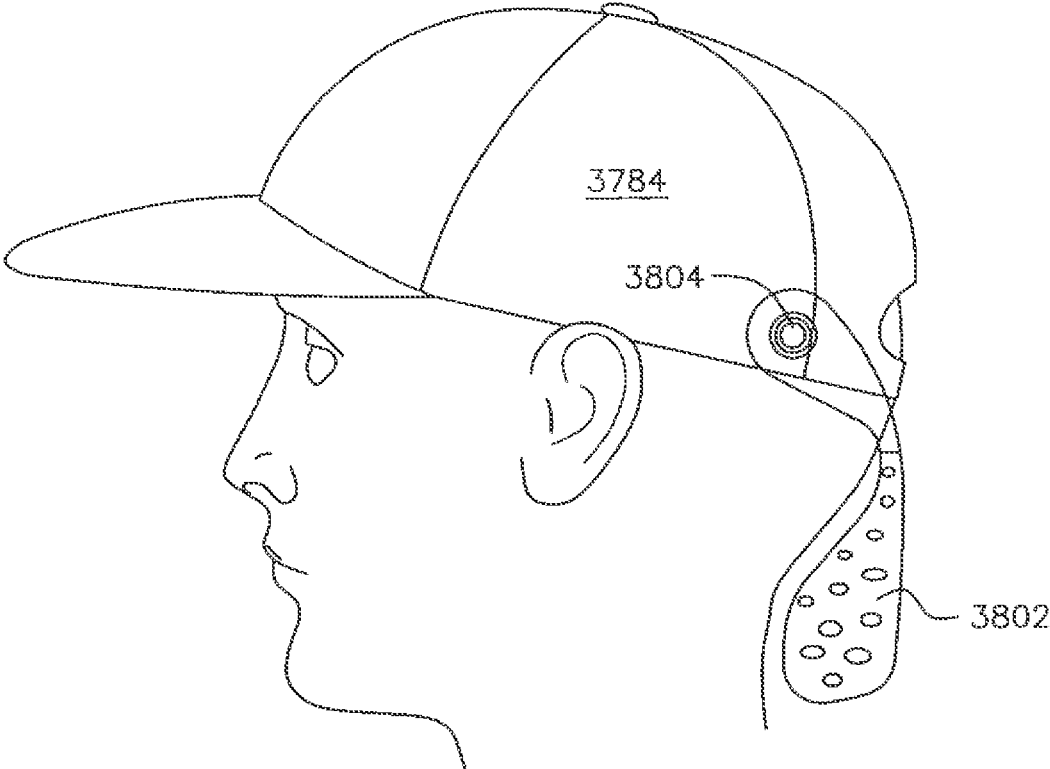

FIG. 156

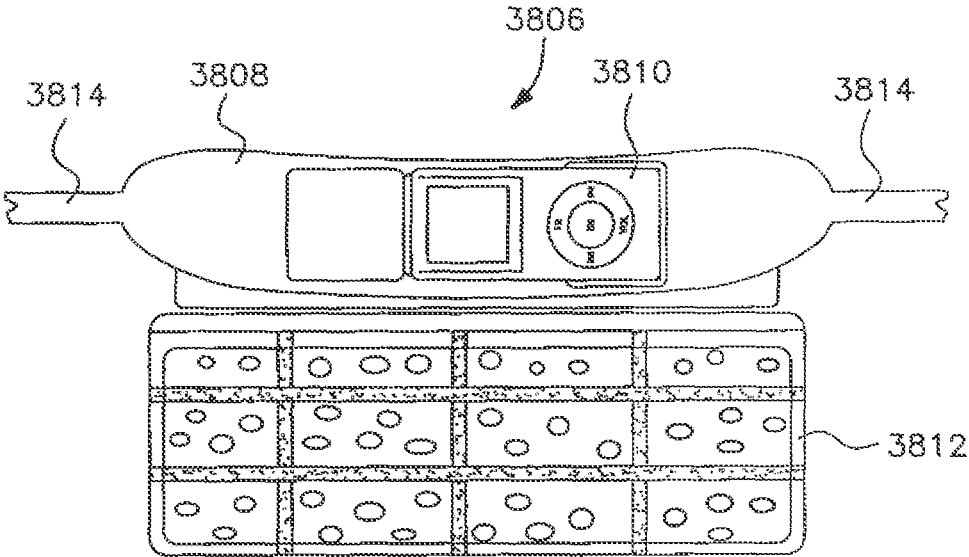

FIG. 157

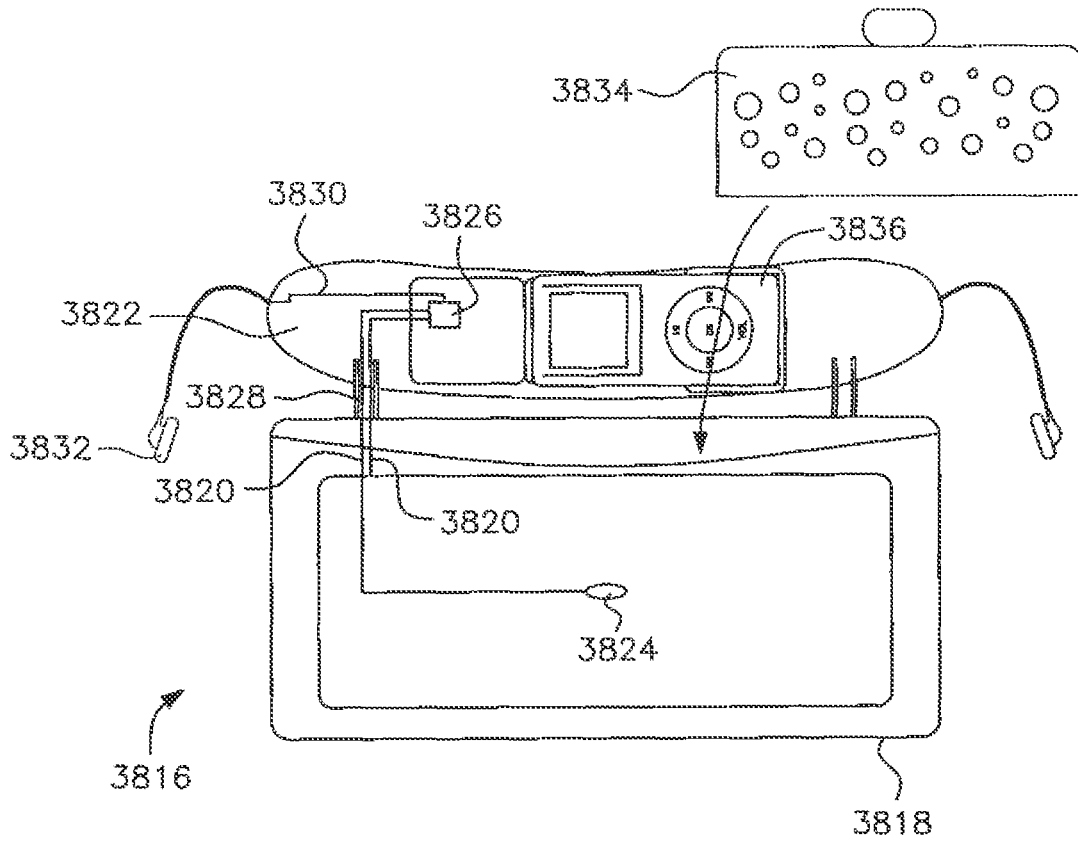

FIG. 158

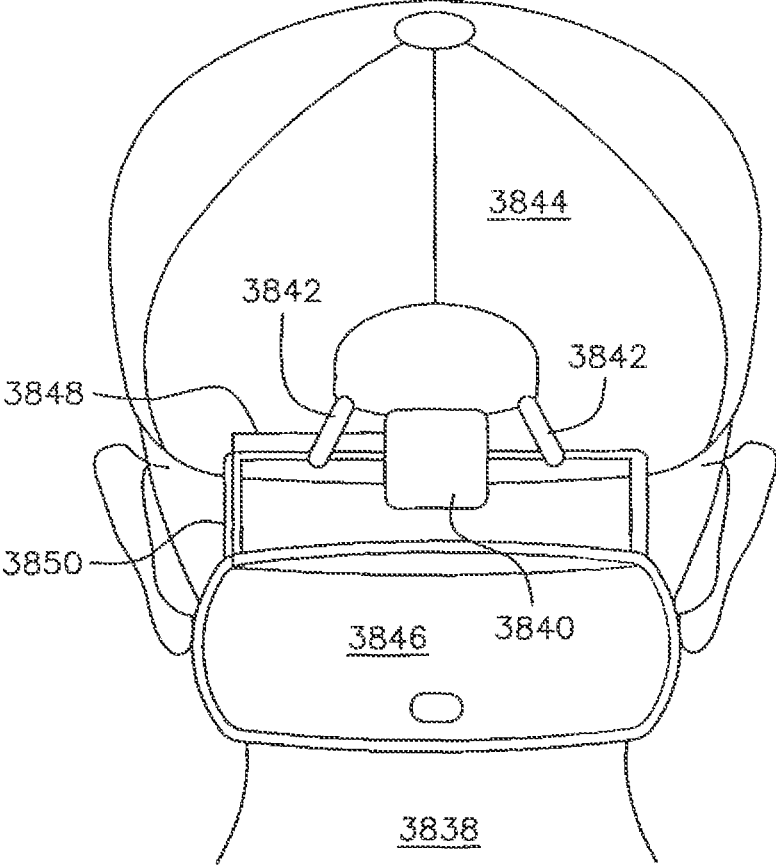

FIG. 159

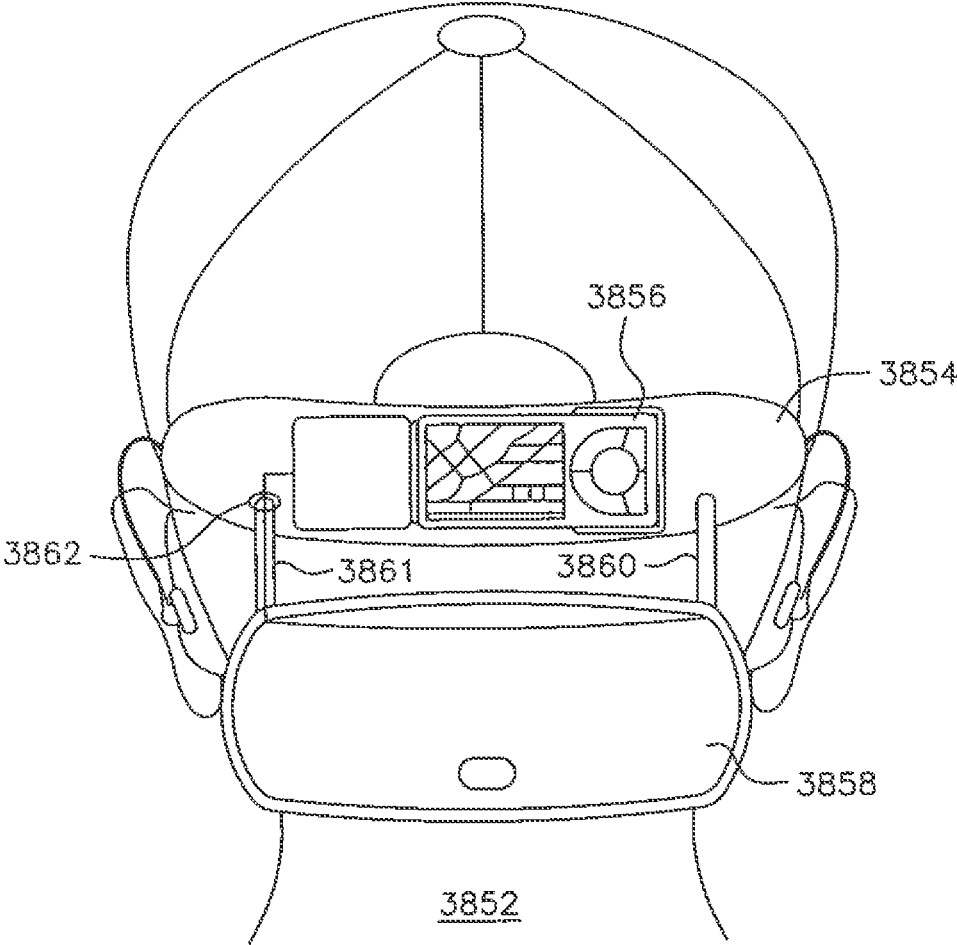

FIG. 160

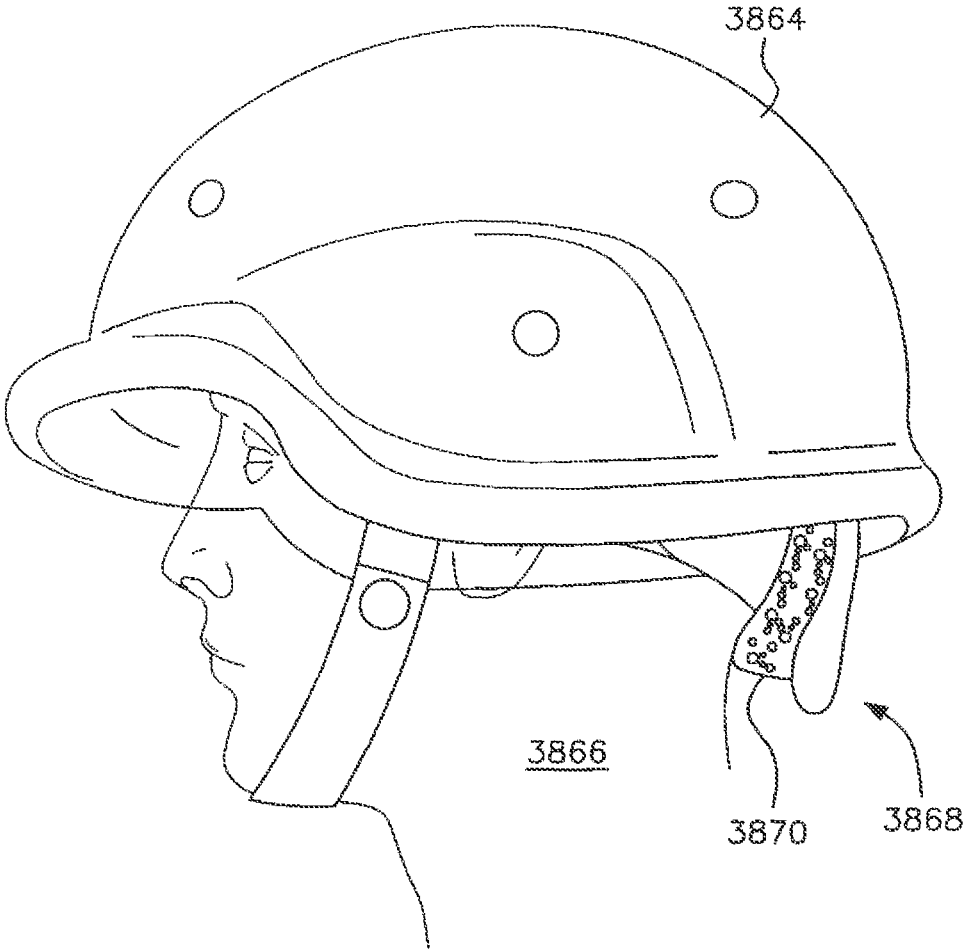

FIG. 161

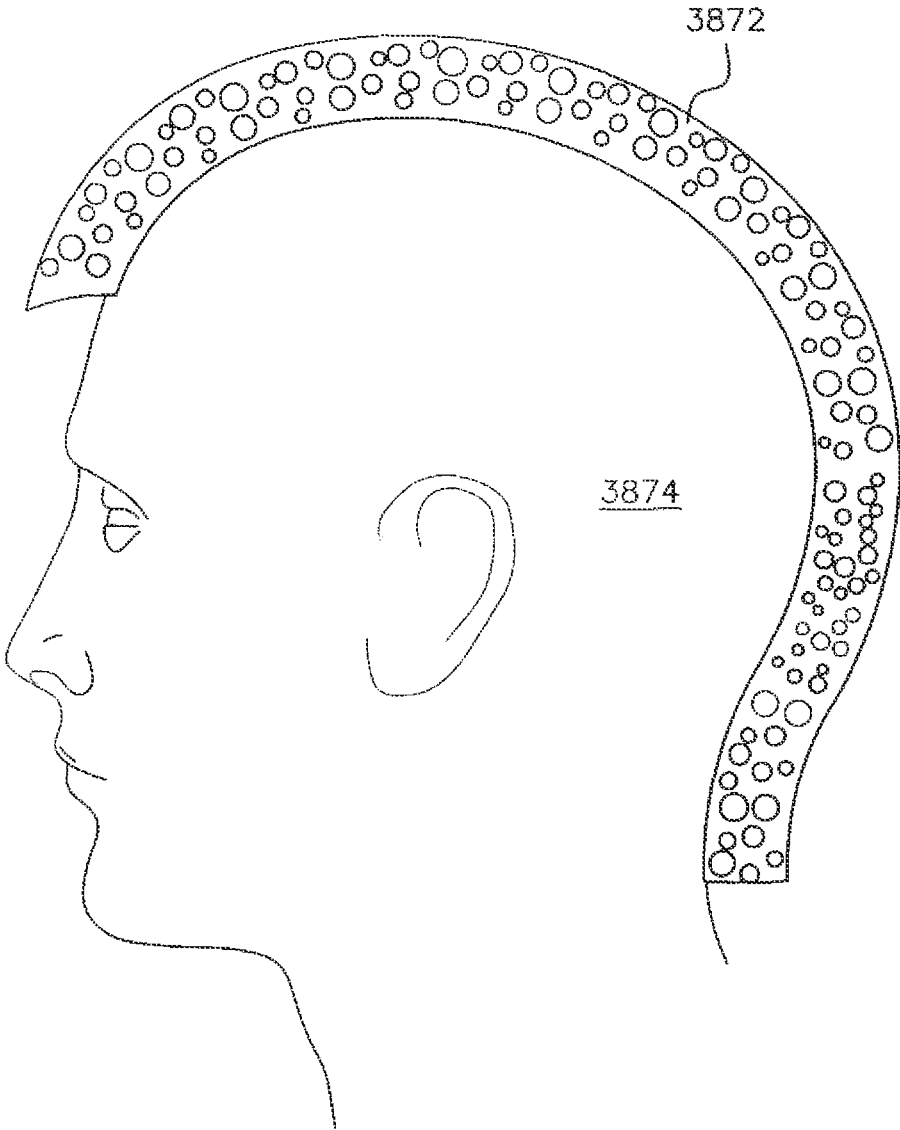

FIG. 162

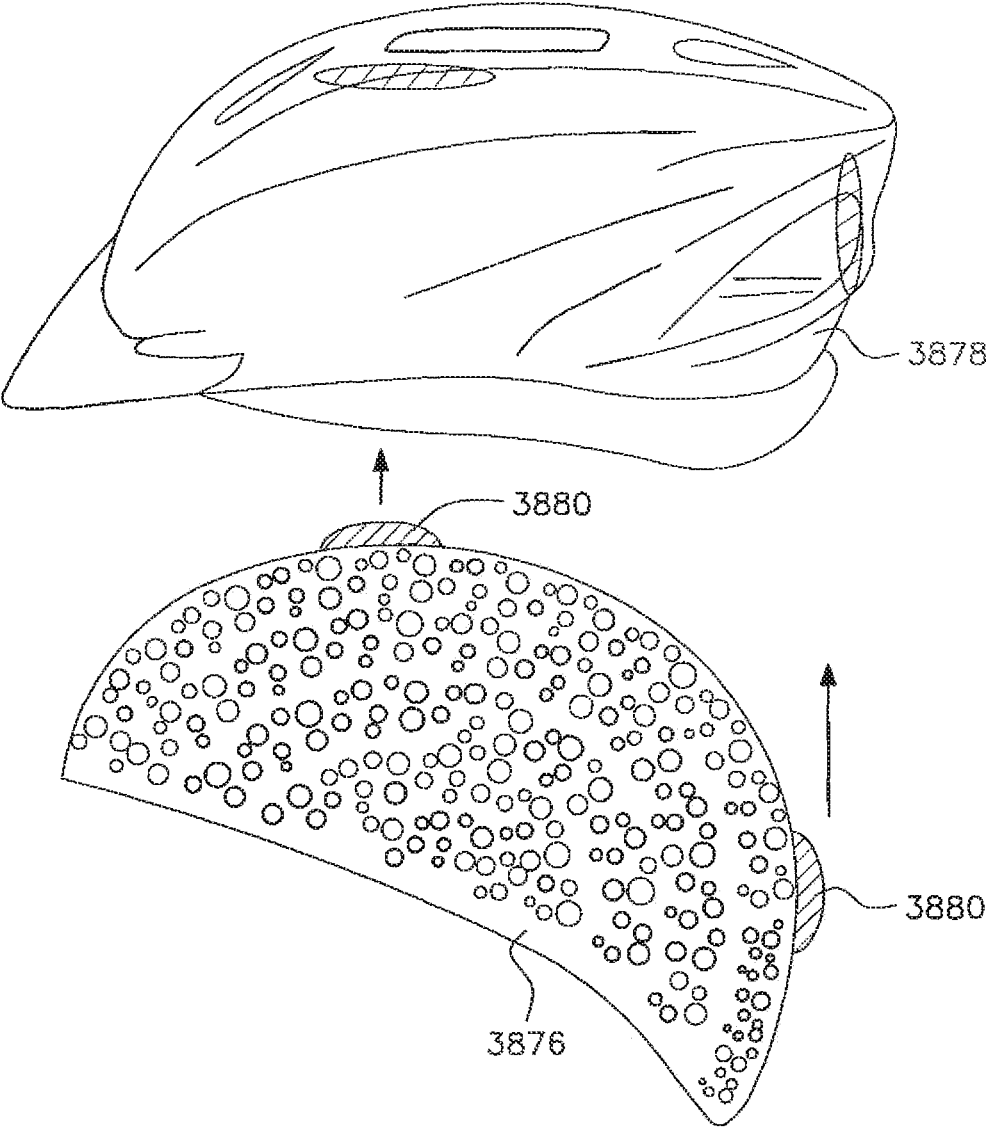

FIG. 163

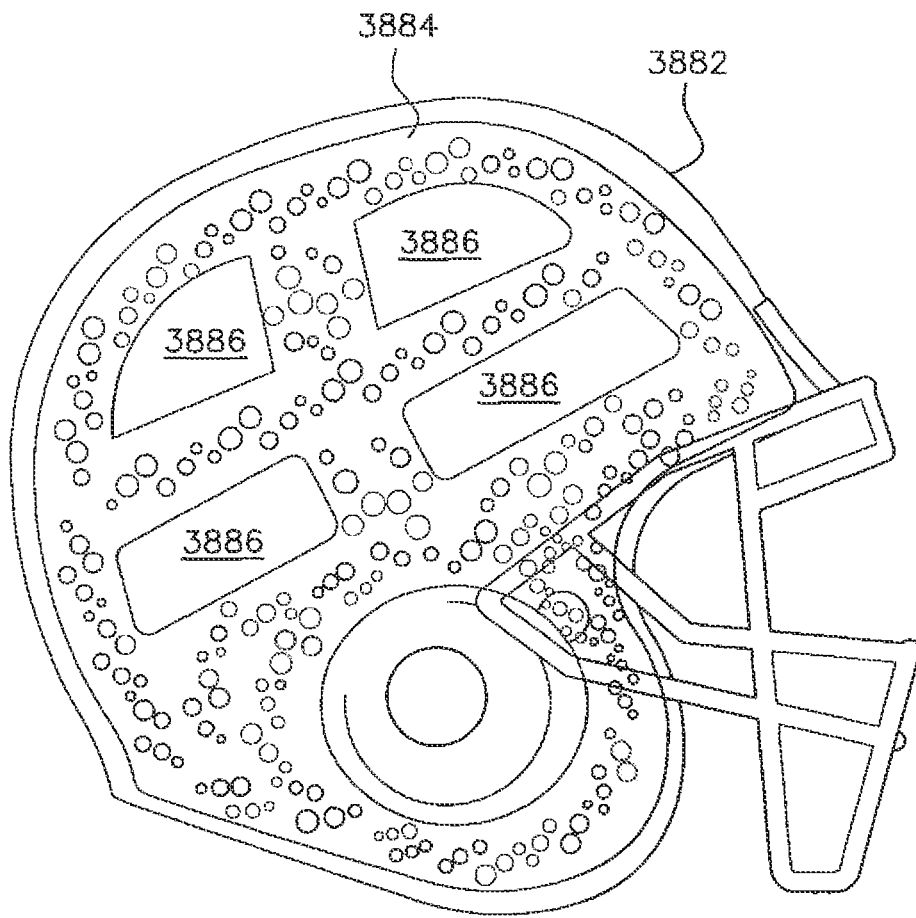

FIG. 164

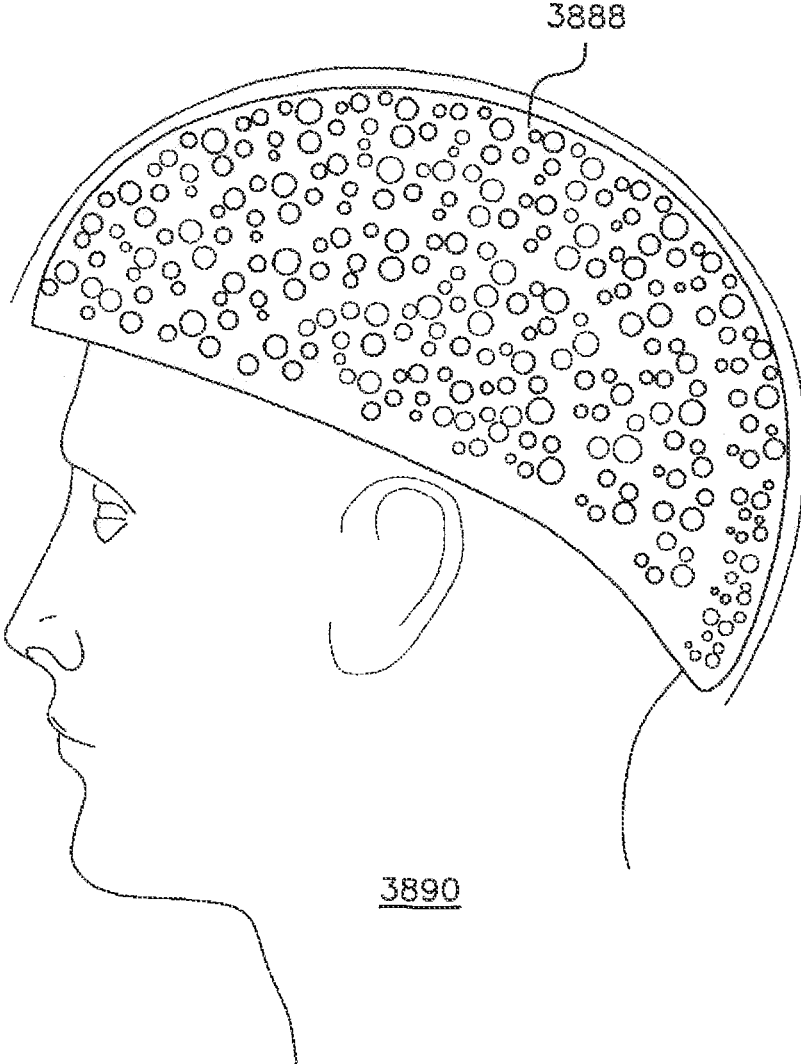

FIG. 165

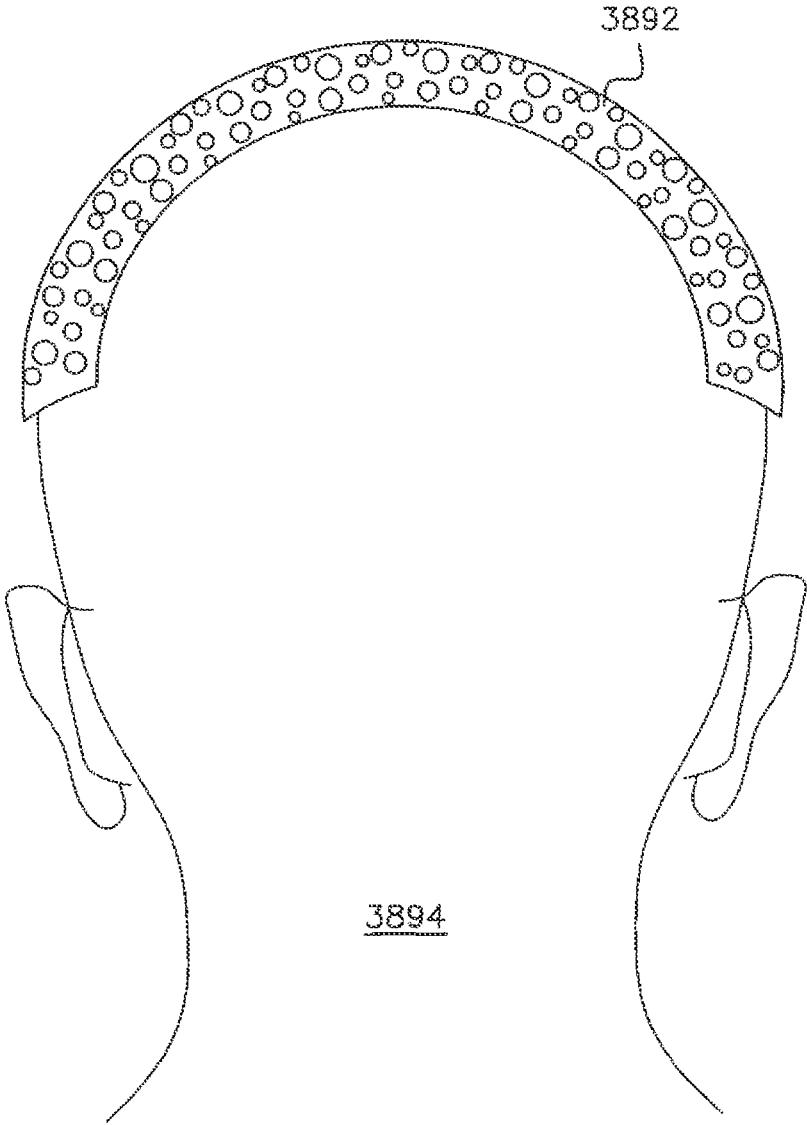

FIG. 166

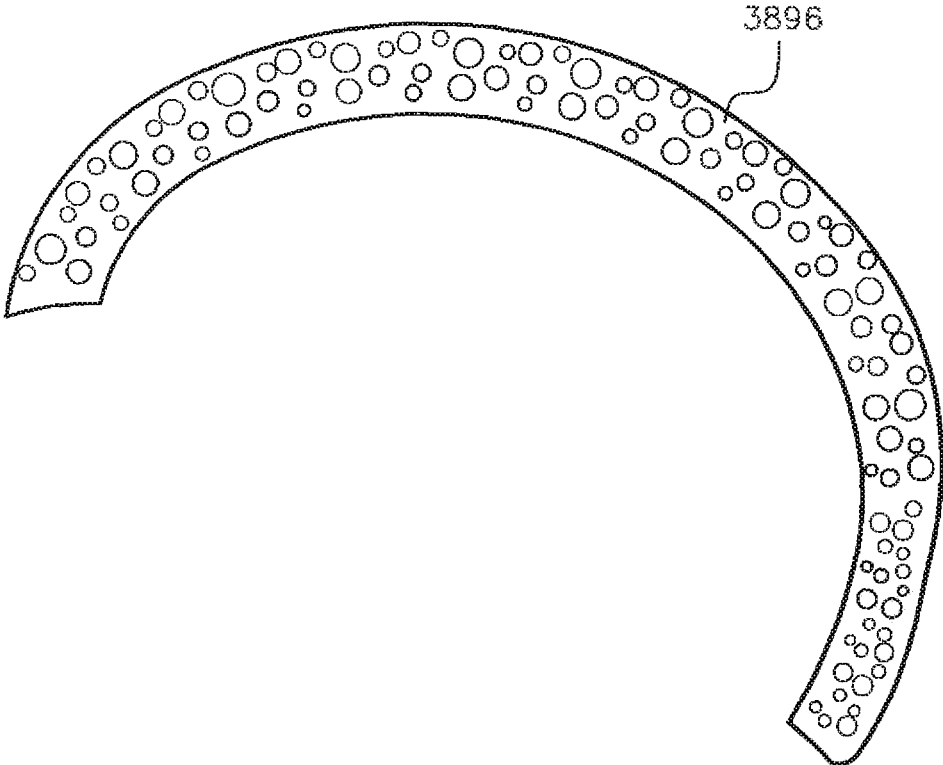

FIG. 167A

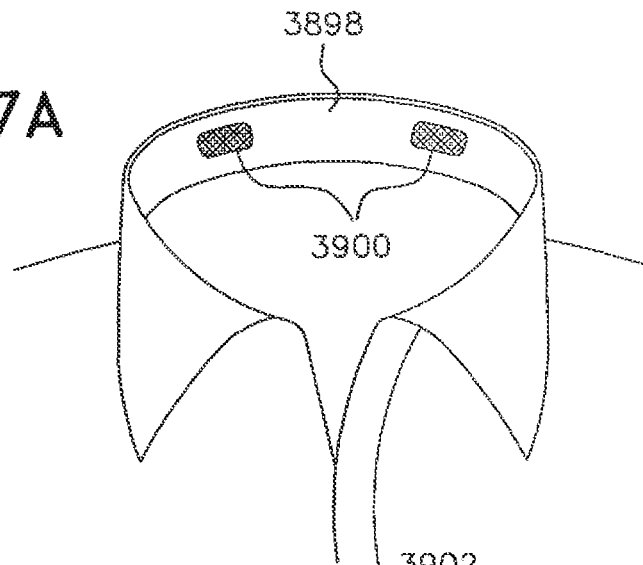

FIG. 167B

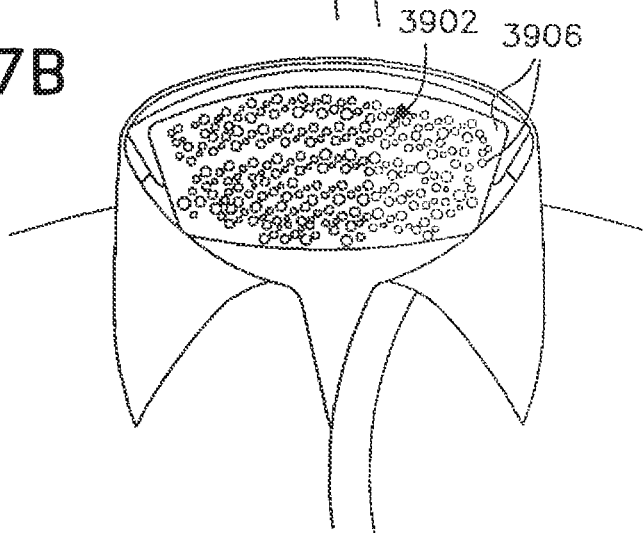

FIG. 167C

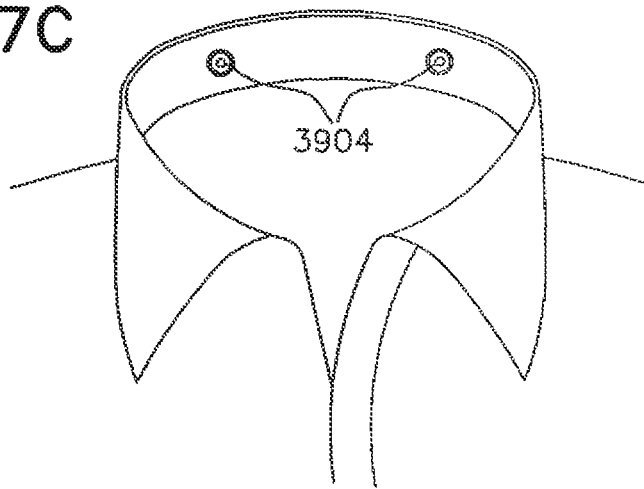

FIG. 168

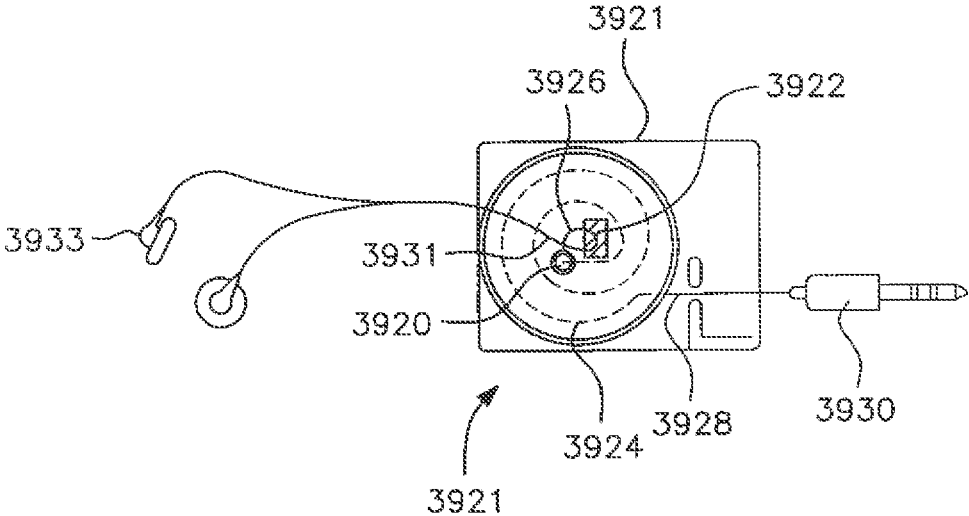

FIG. 169A

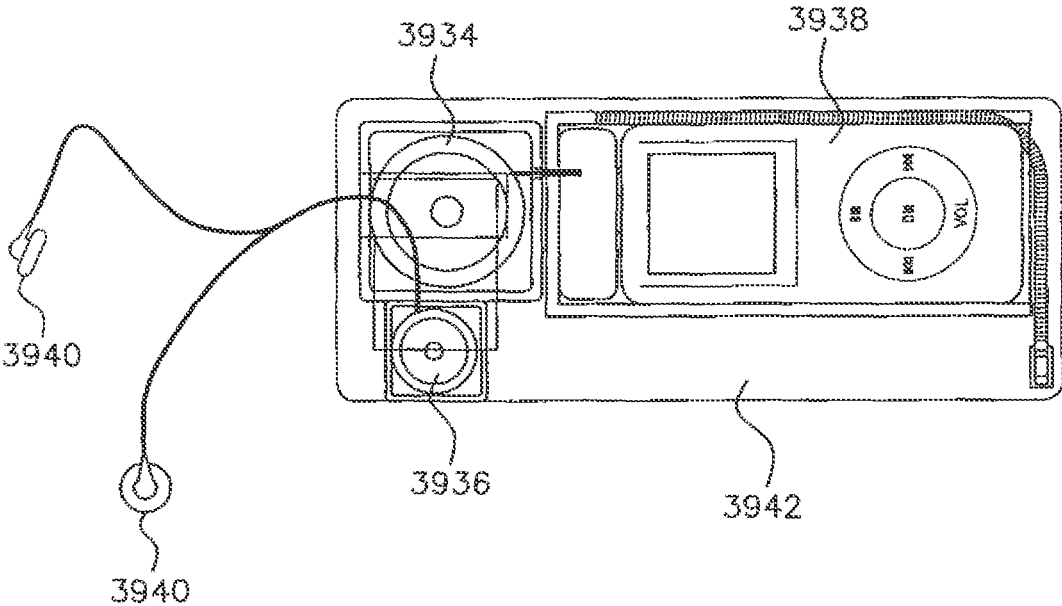

FIG. 169B

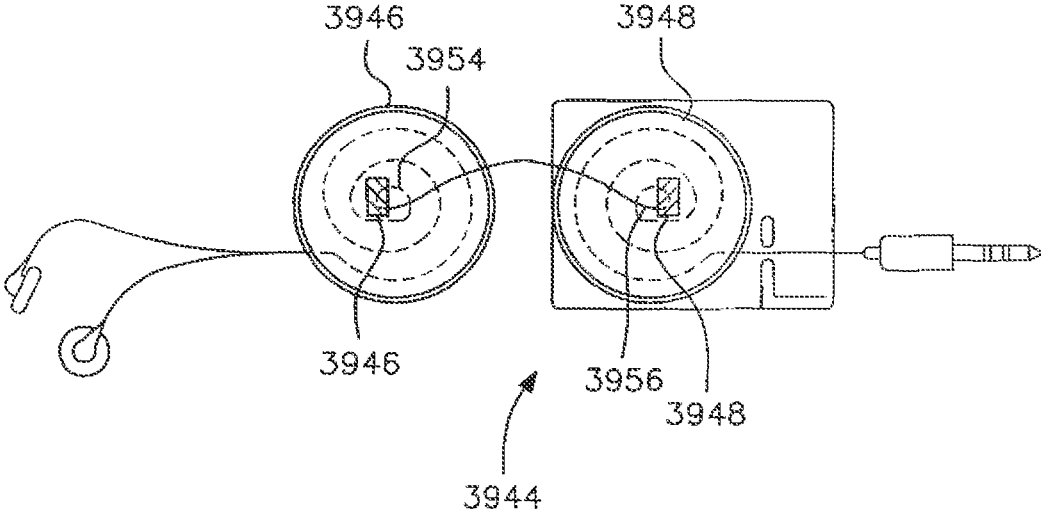

FIG. 170

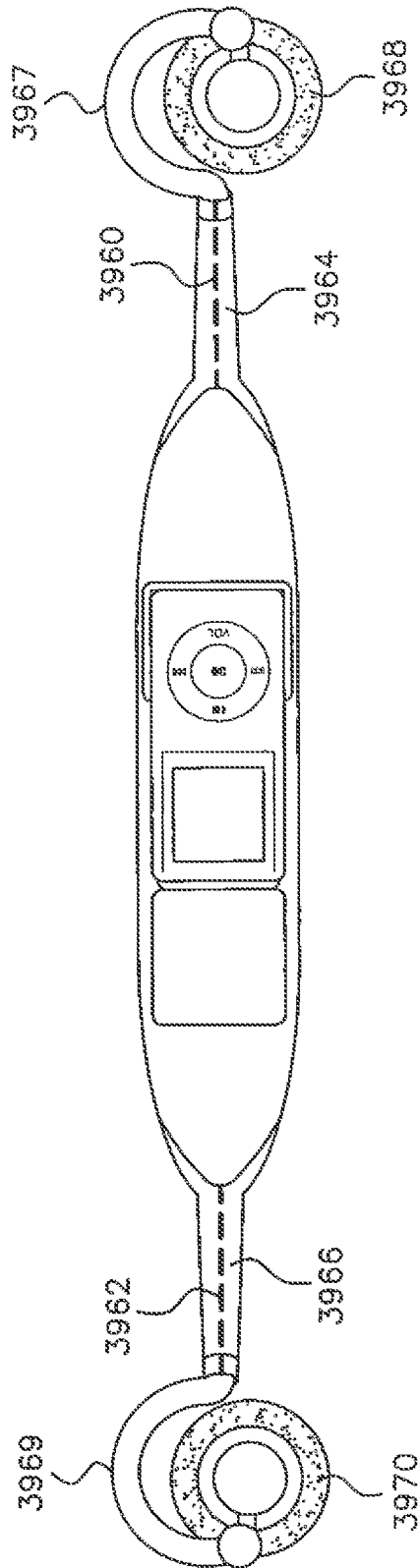

FIG. 171A

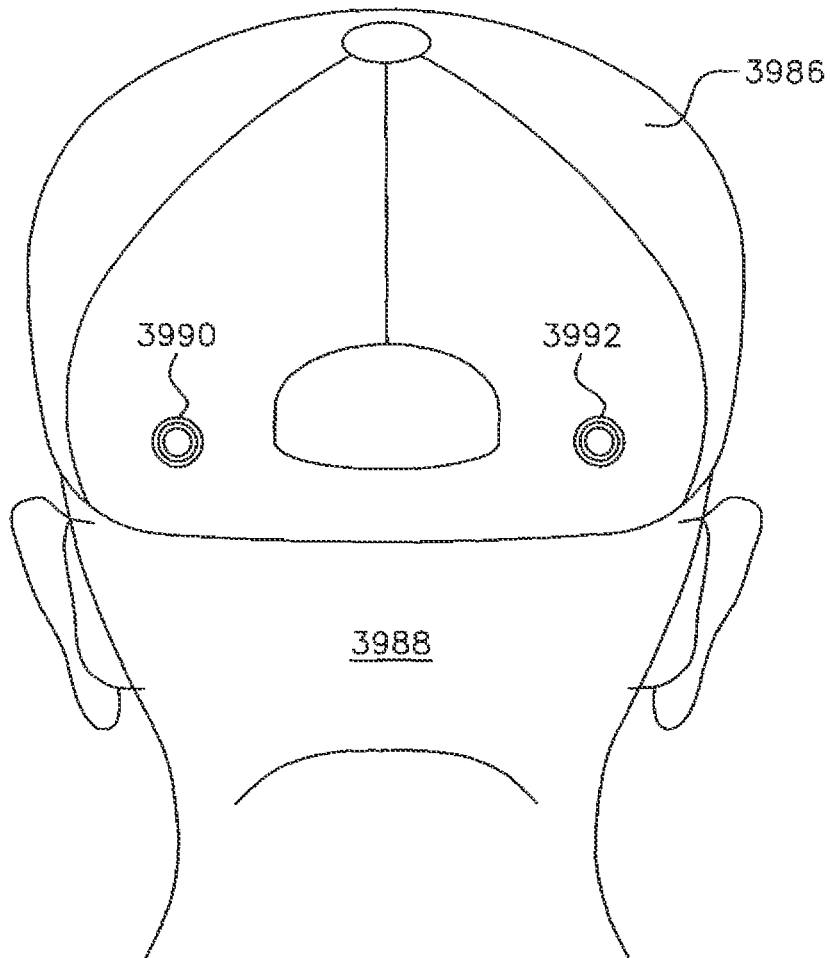

FIG. 171B

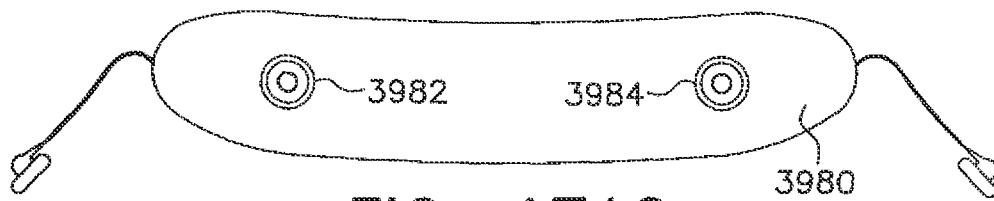

FIG. 171C

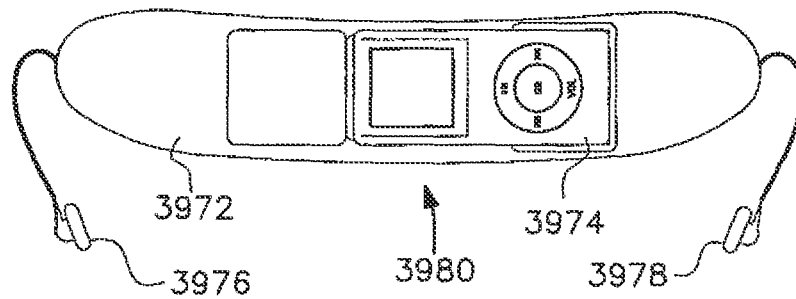

FIG. 171D

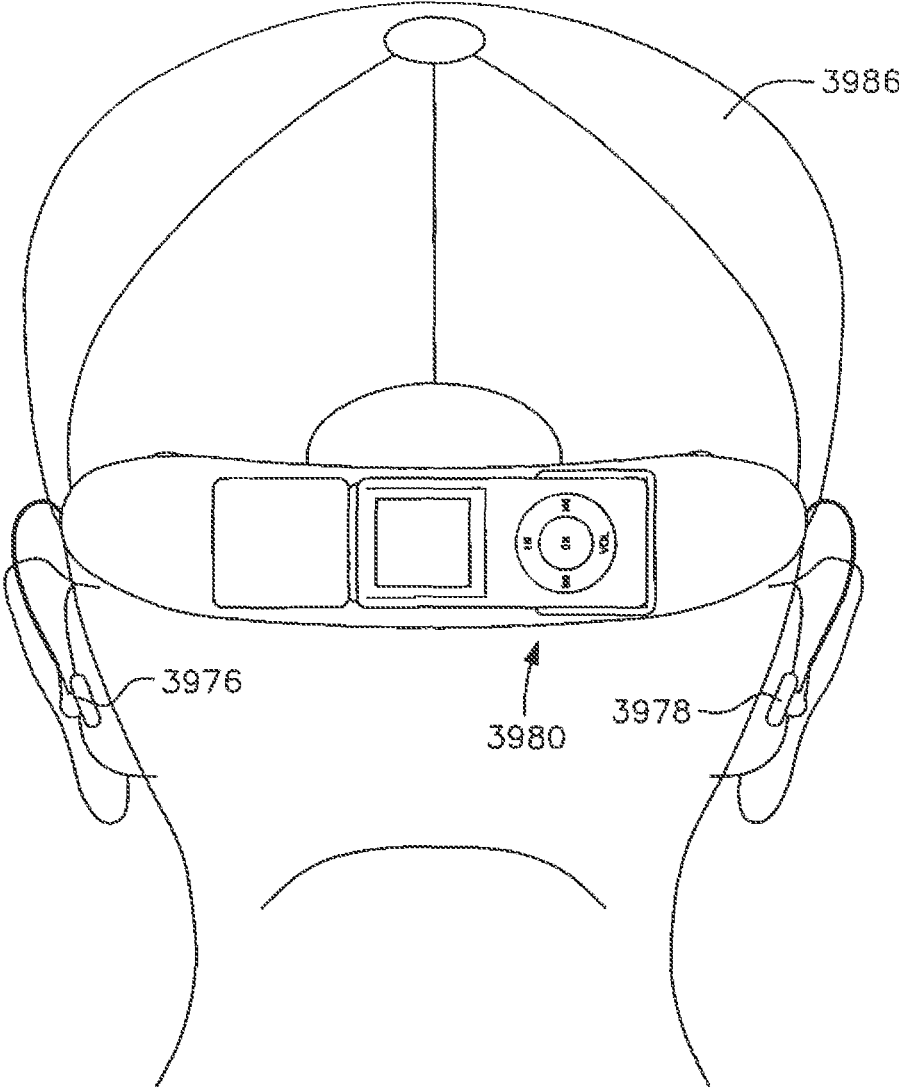

FIG. 172A

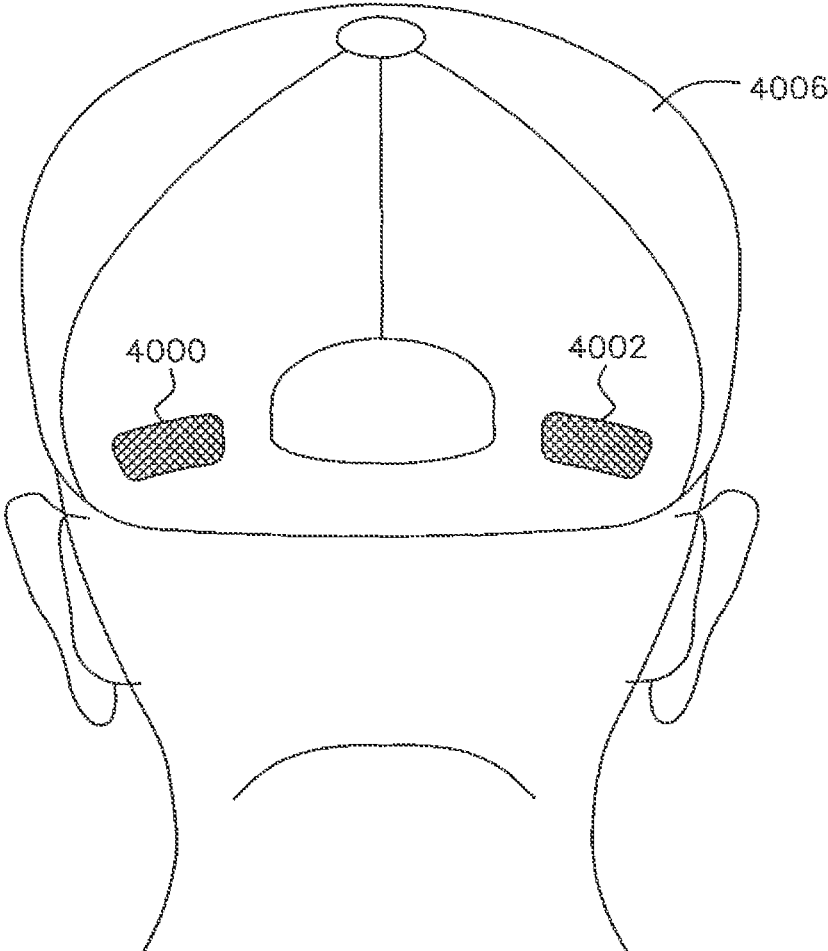

FIG. 172B

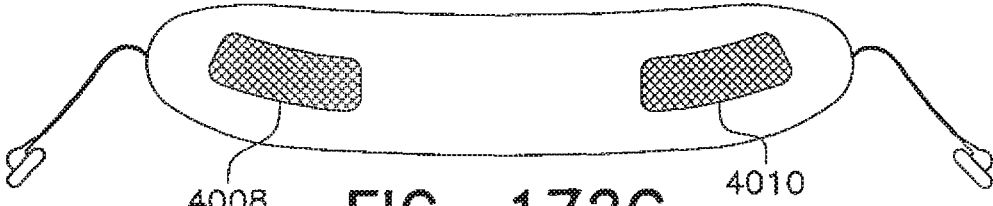

FIG. 172C

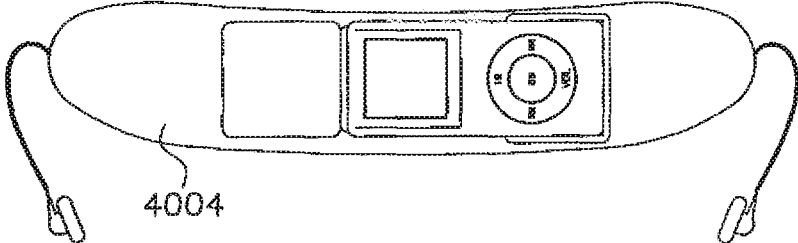

FIG. 173A

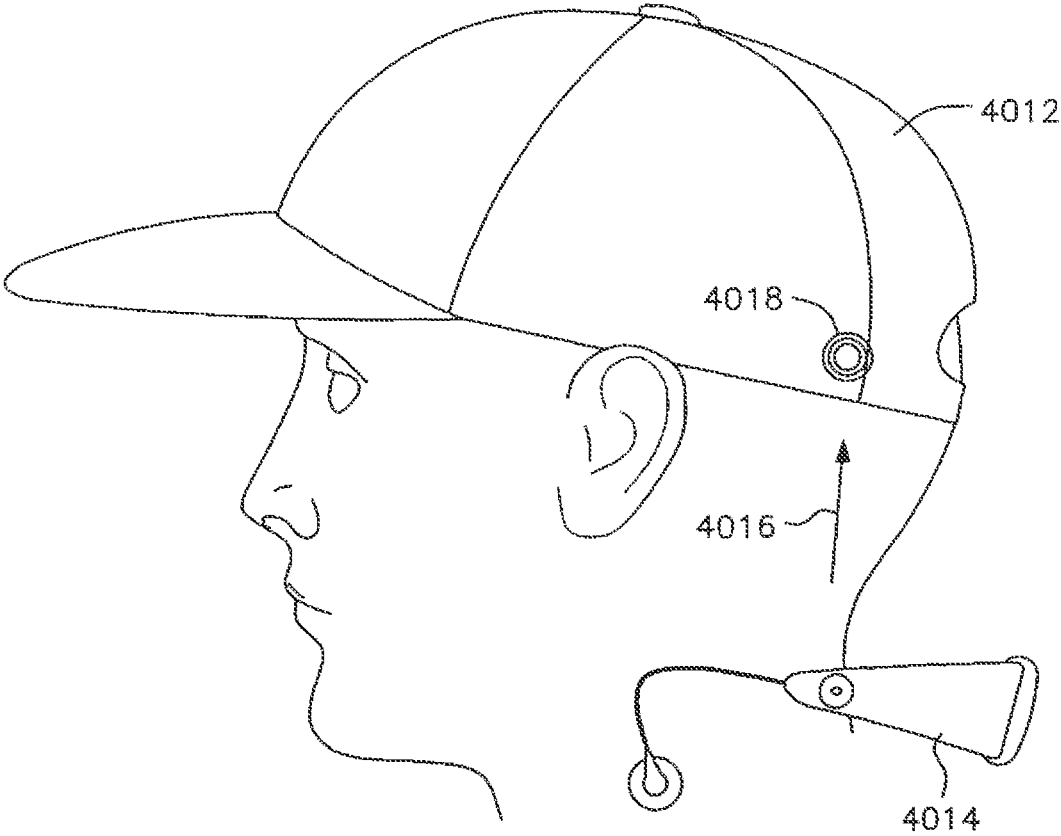

FIG. 173B

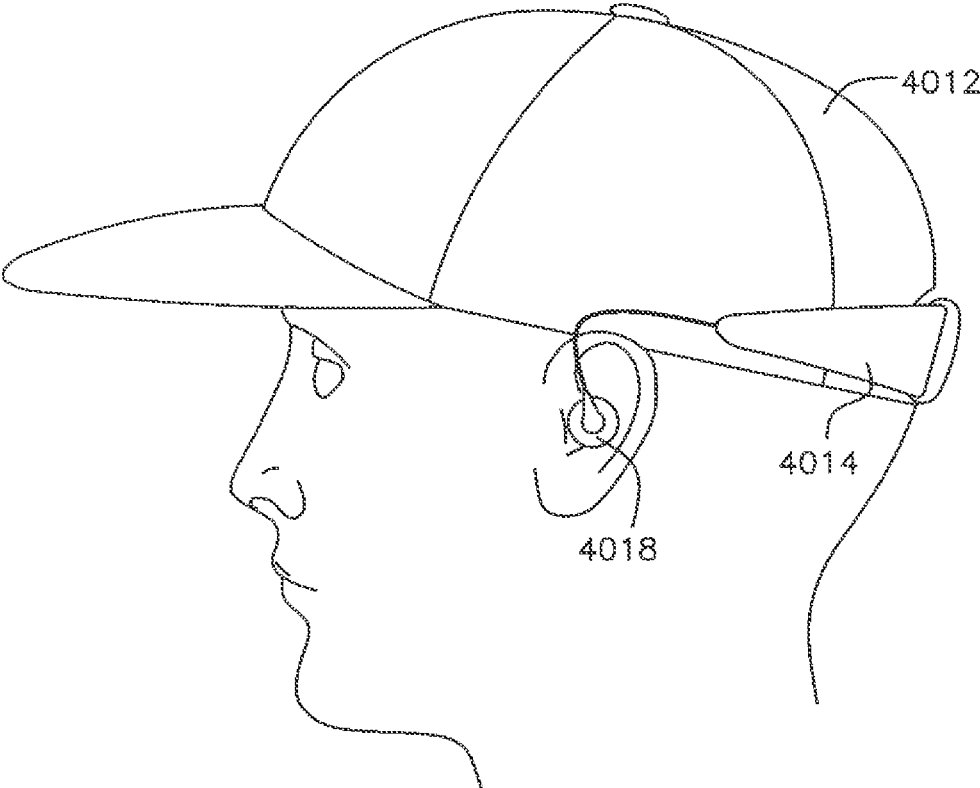

FIG. 174

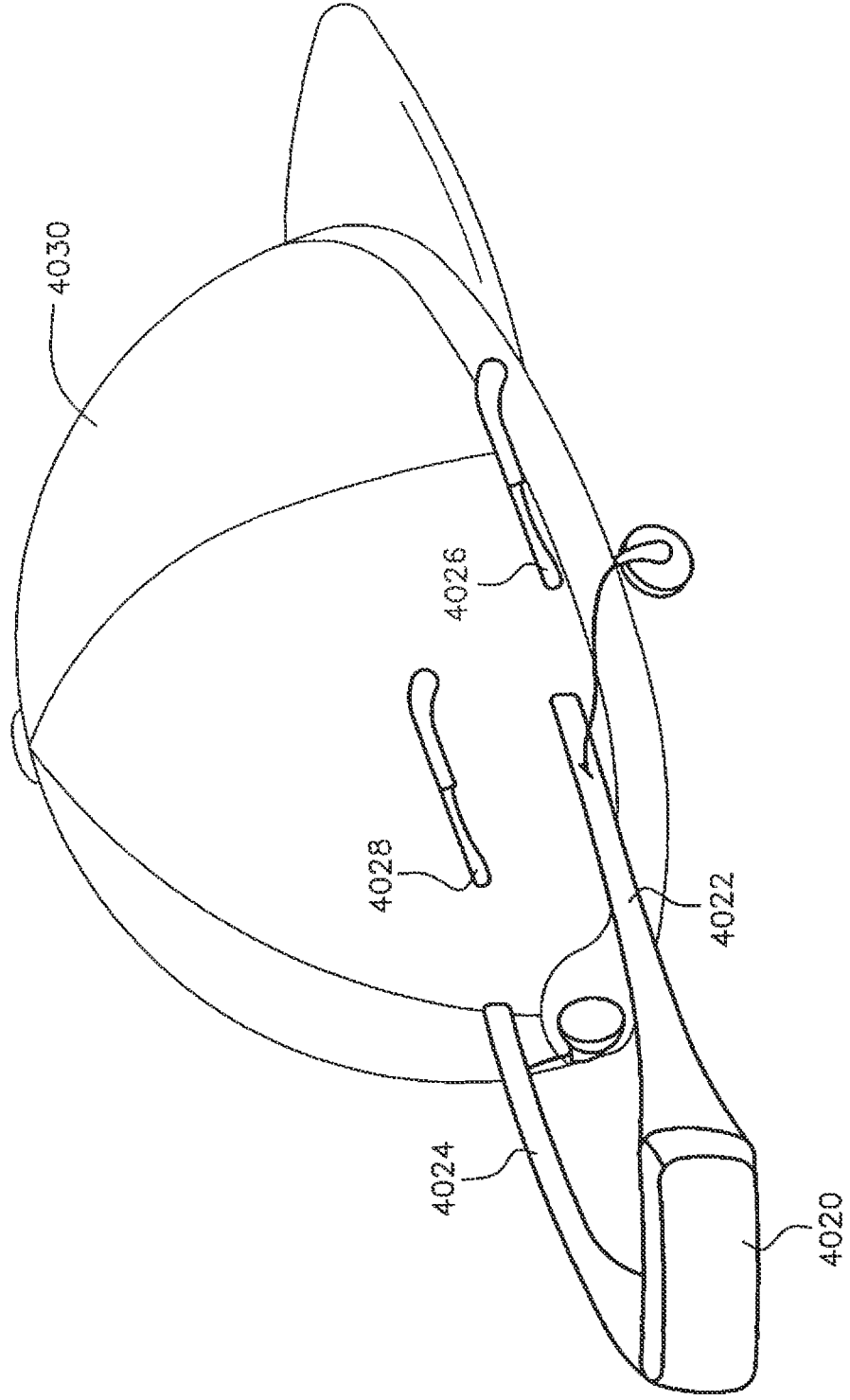

FIG. 175A

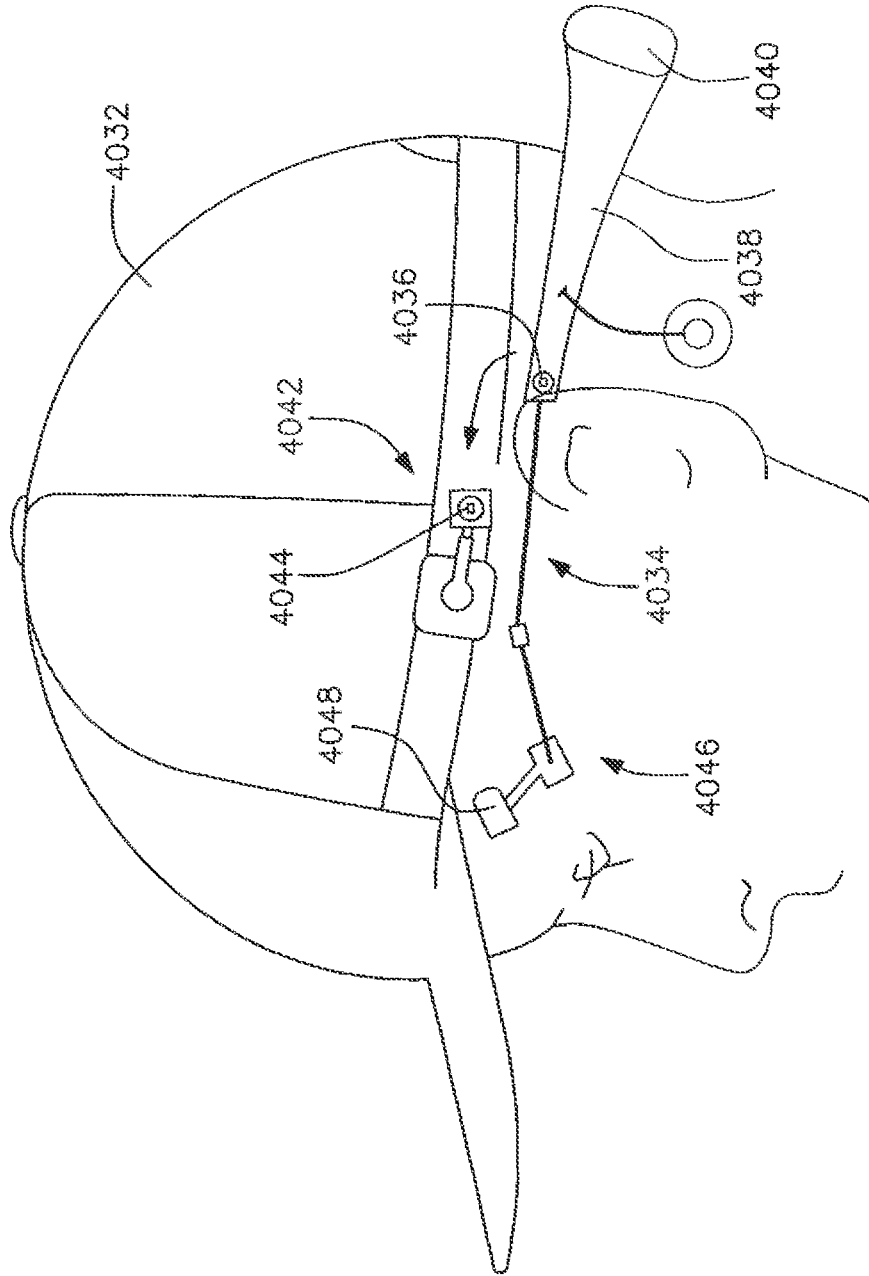

FIG. 175B

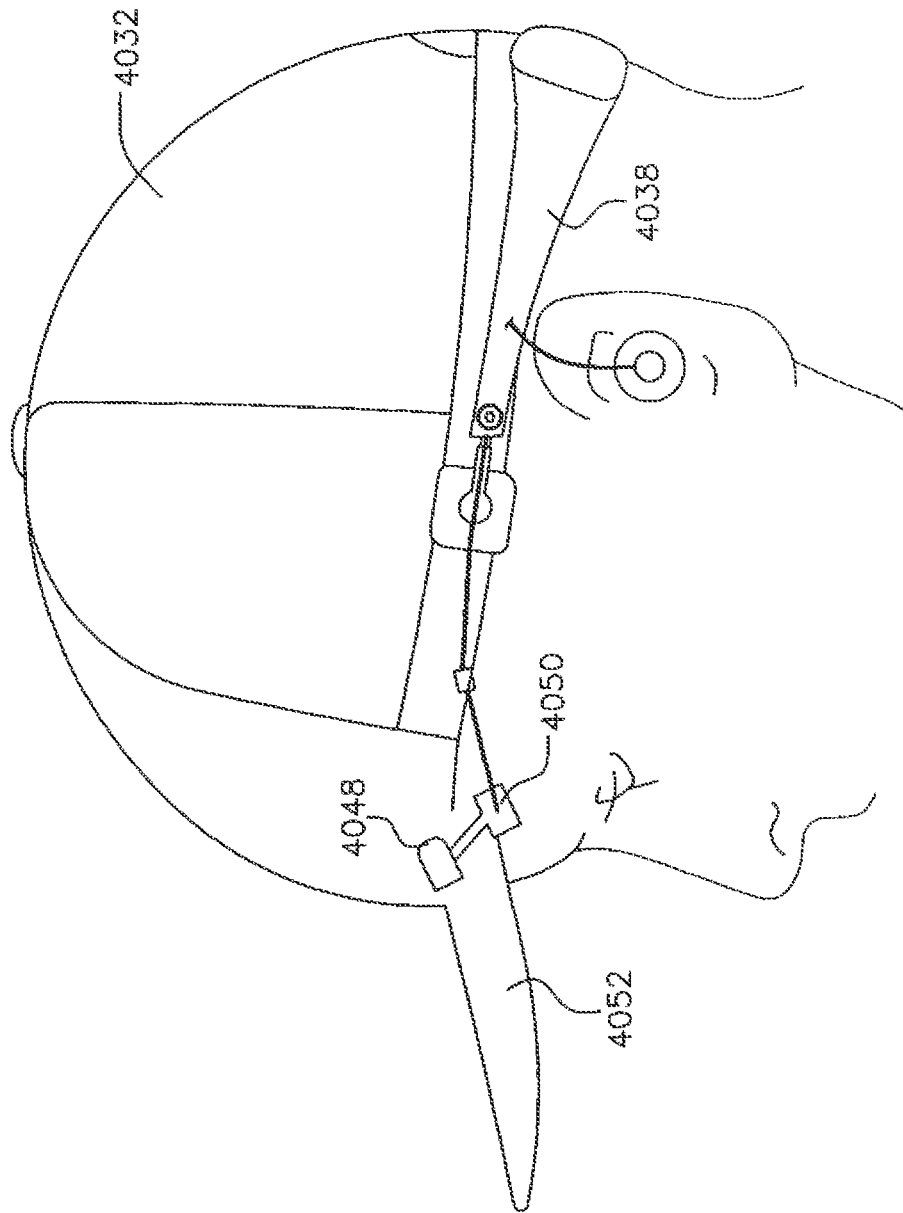

FIG. 176A

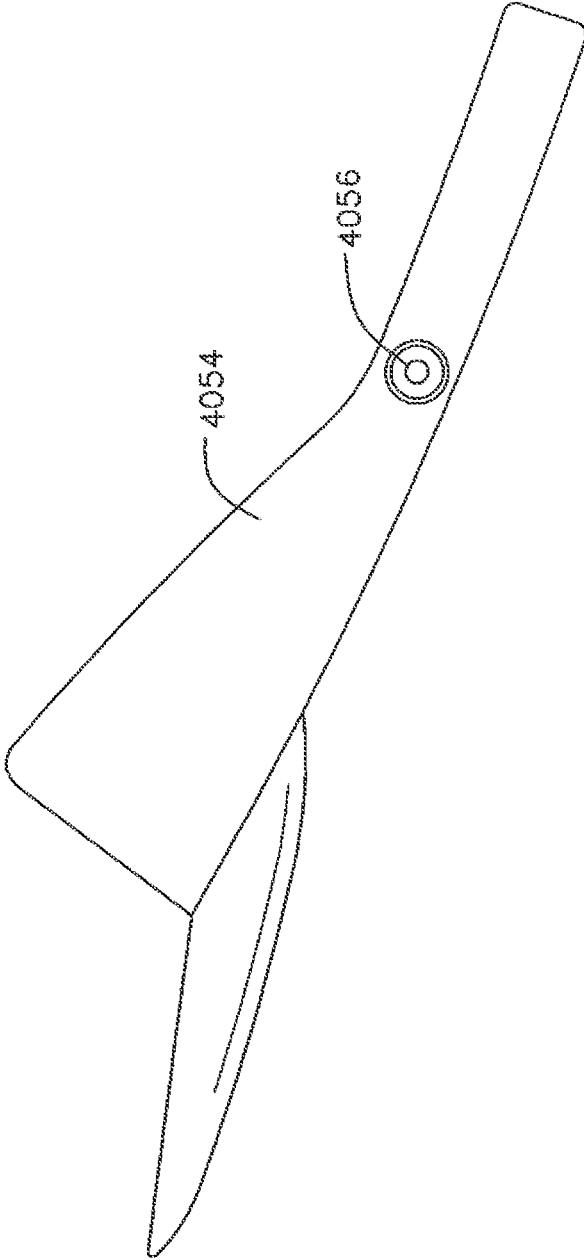

FIG. 176B

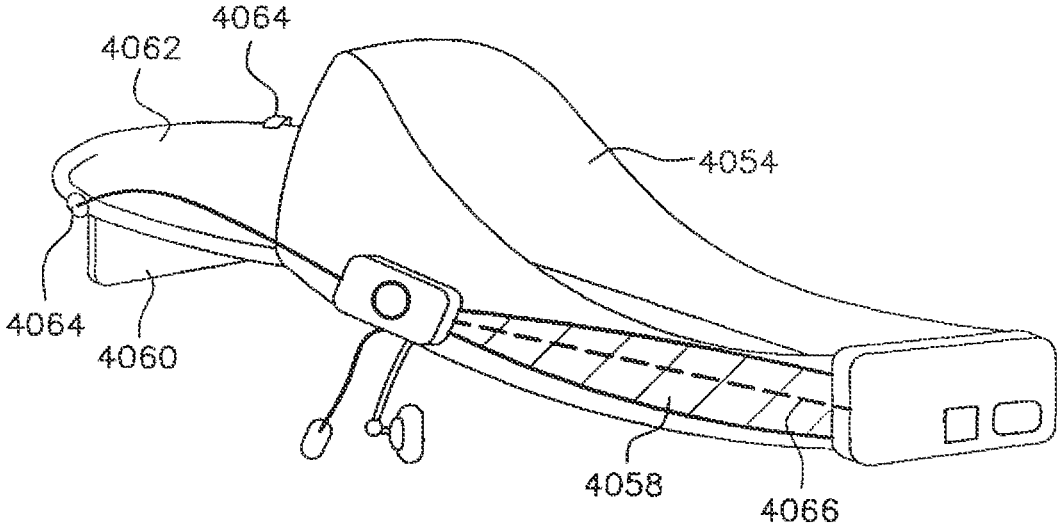

FIG. 177A

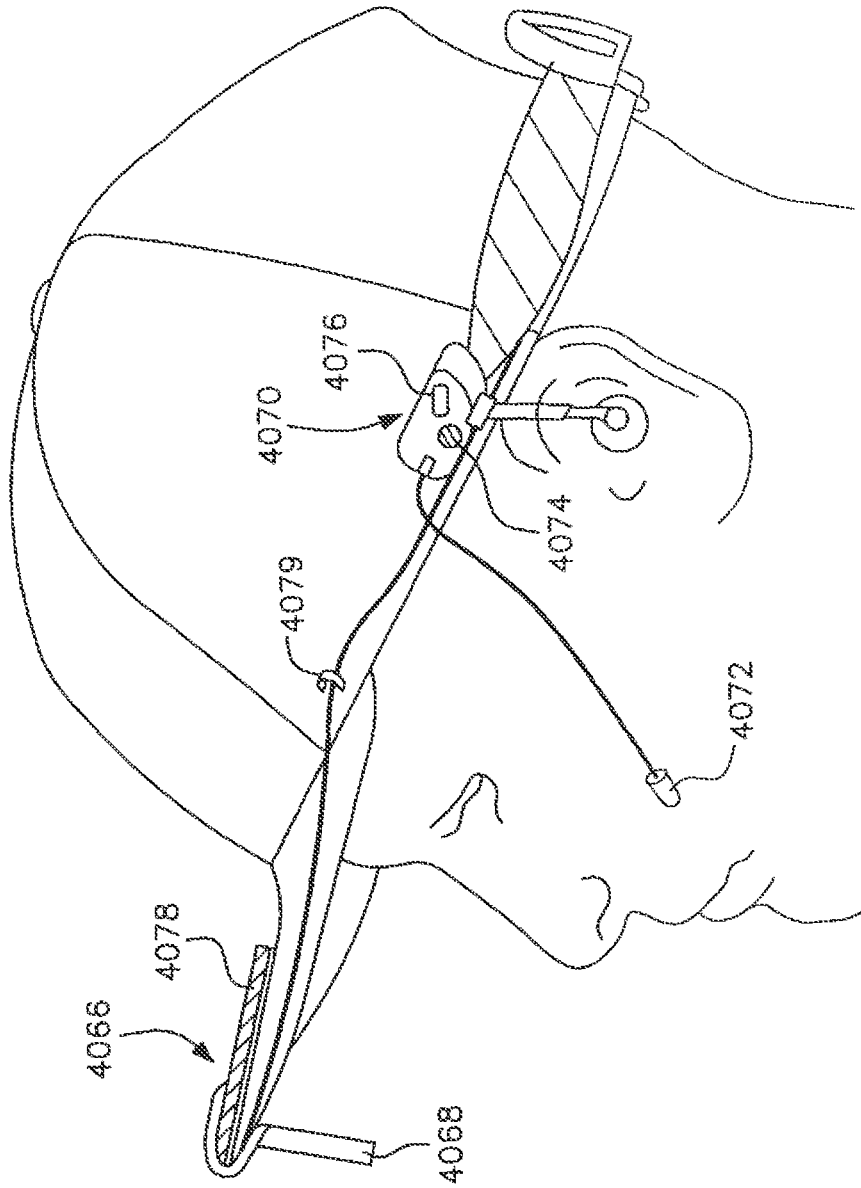

FIG. 177B

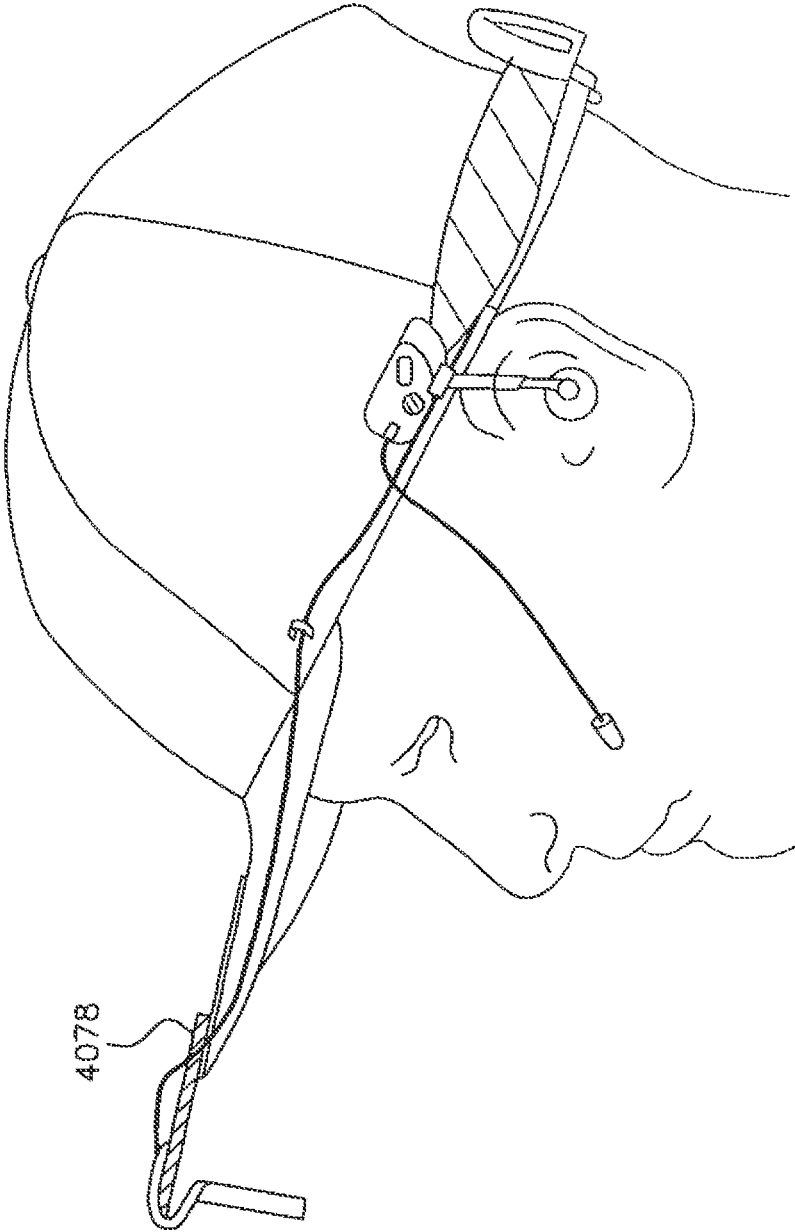

FIG. 178

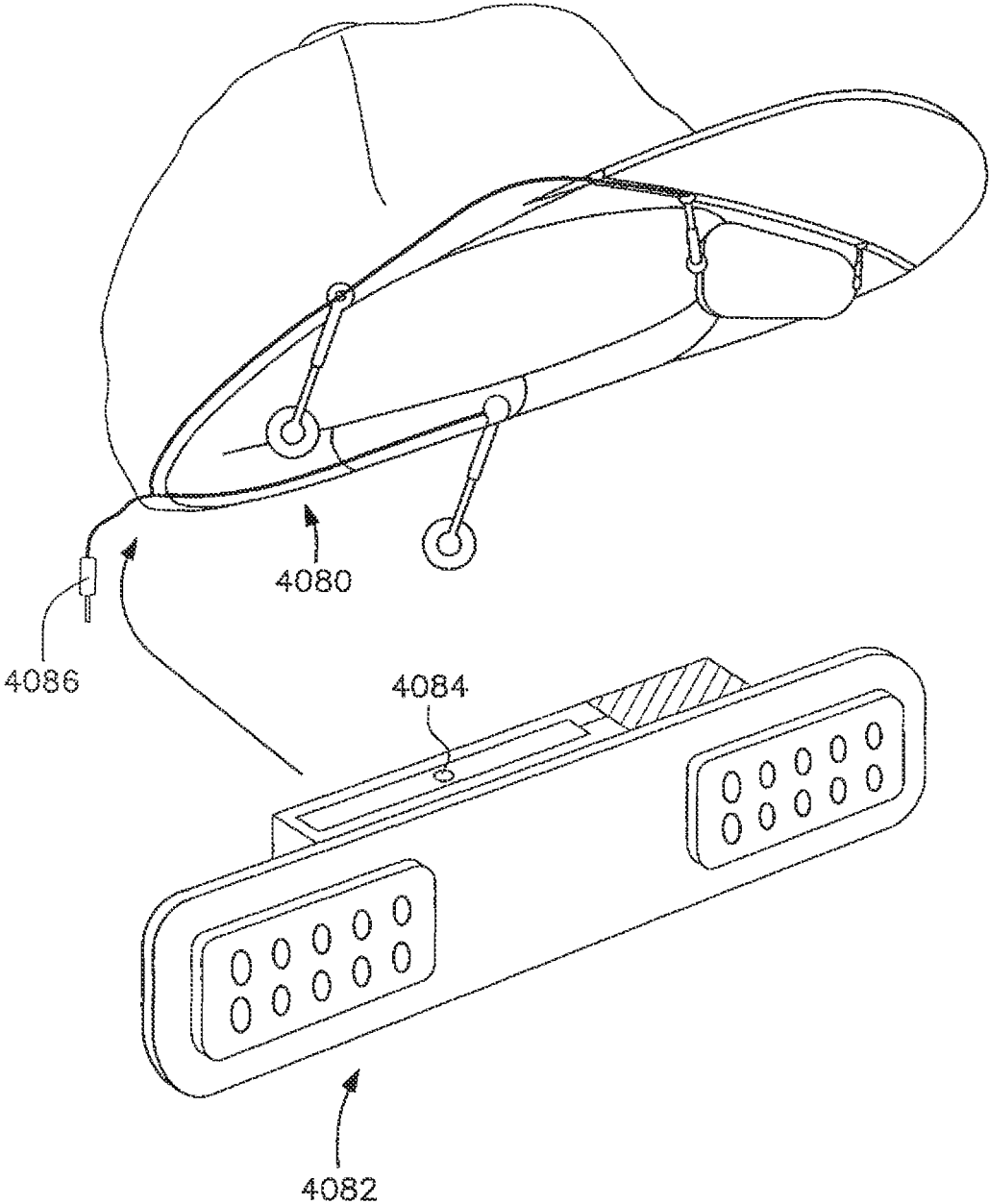

FIG. 179A

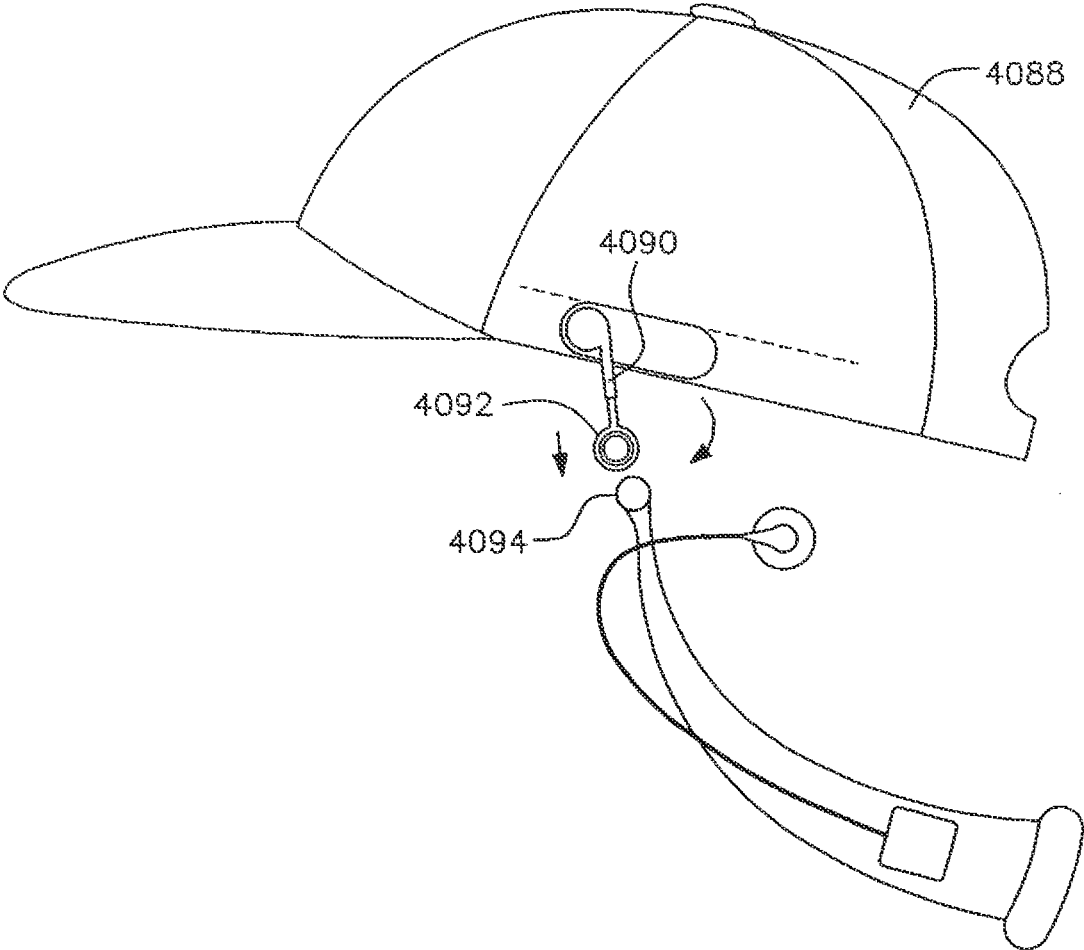

FIG. 179B

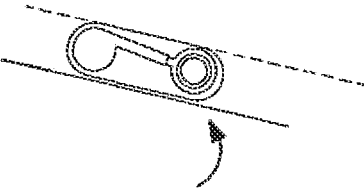

FIG. 179C

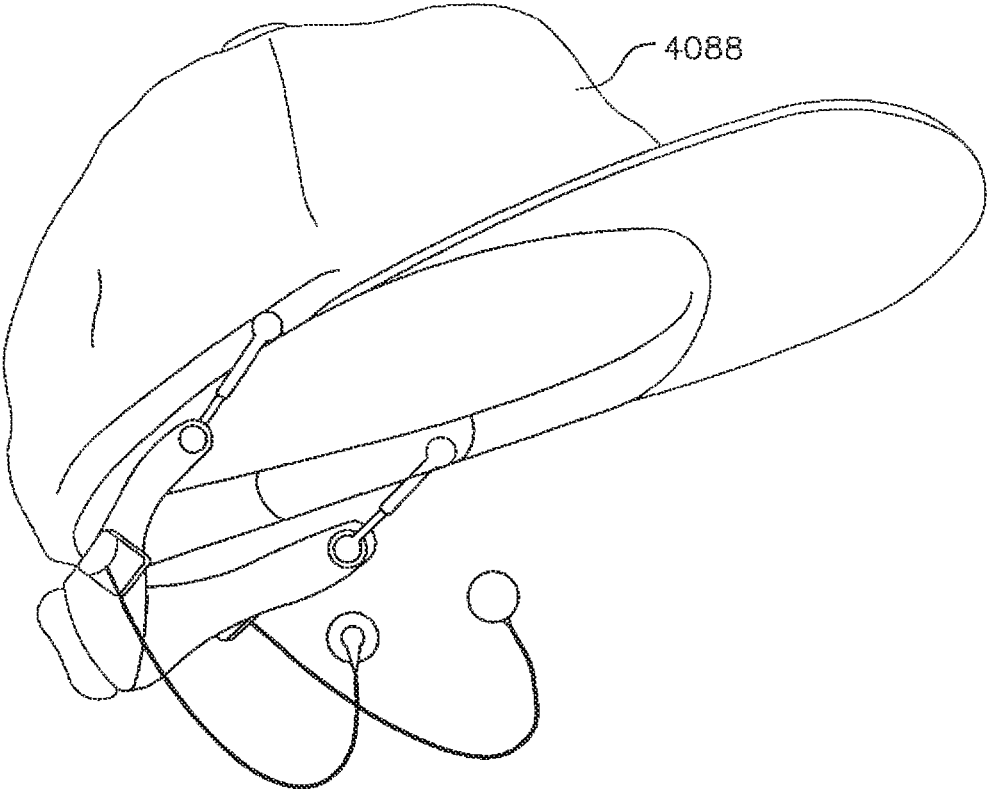
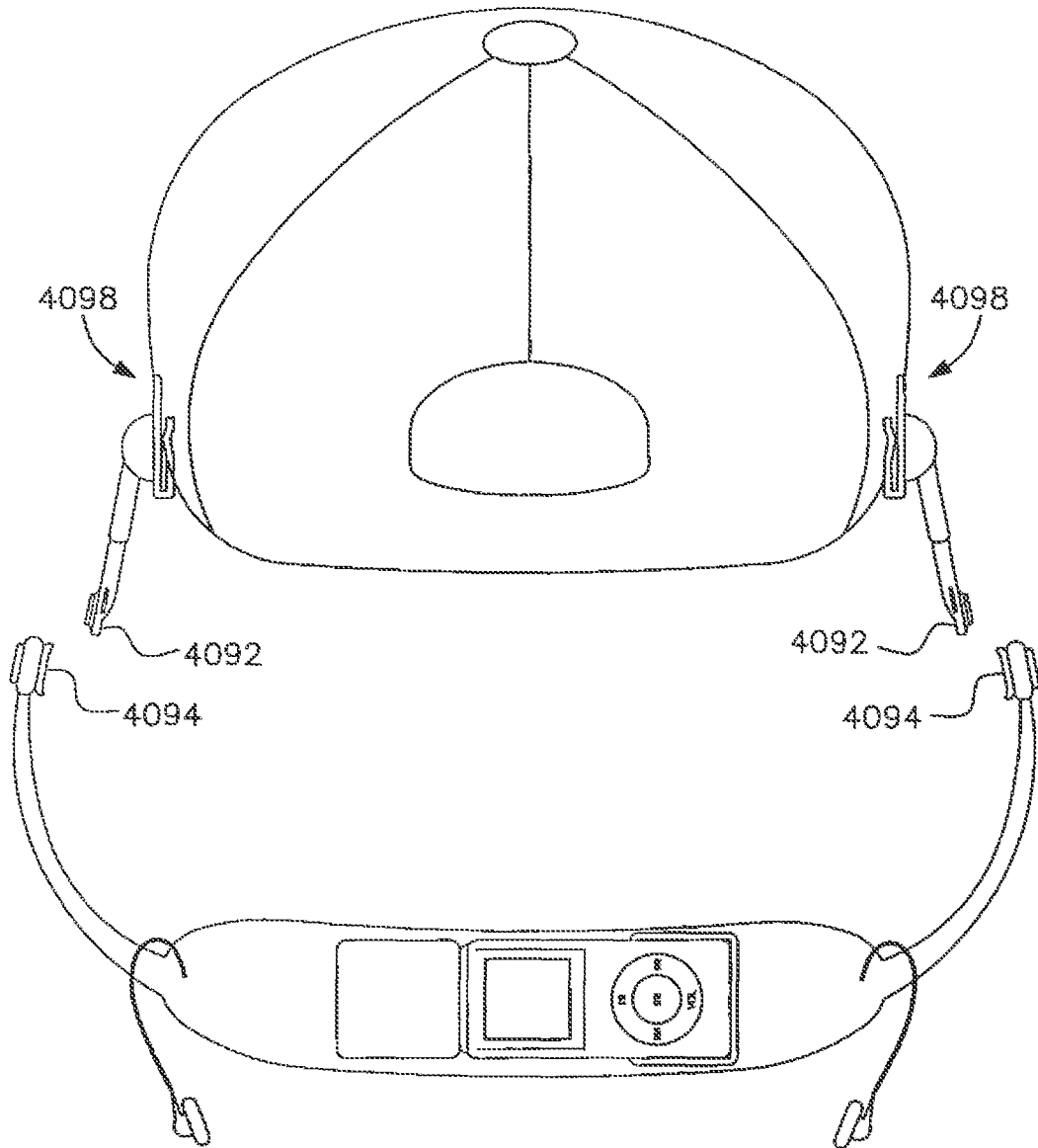

FIG. 179D



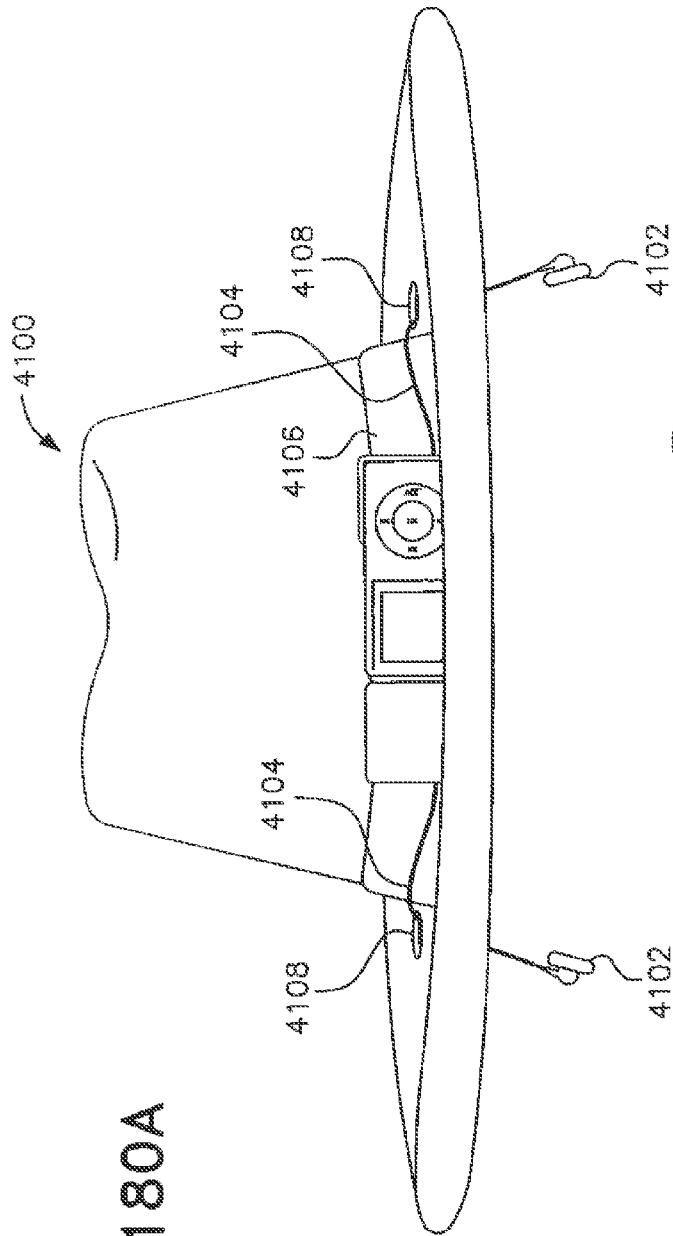

FIG. 180A

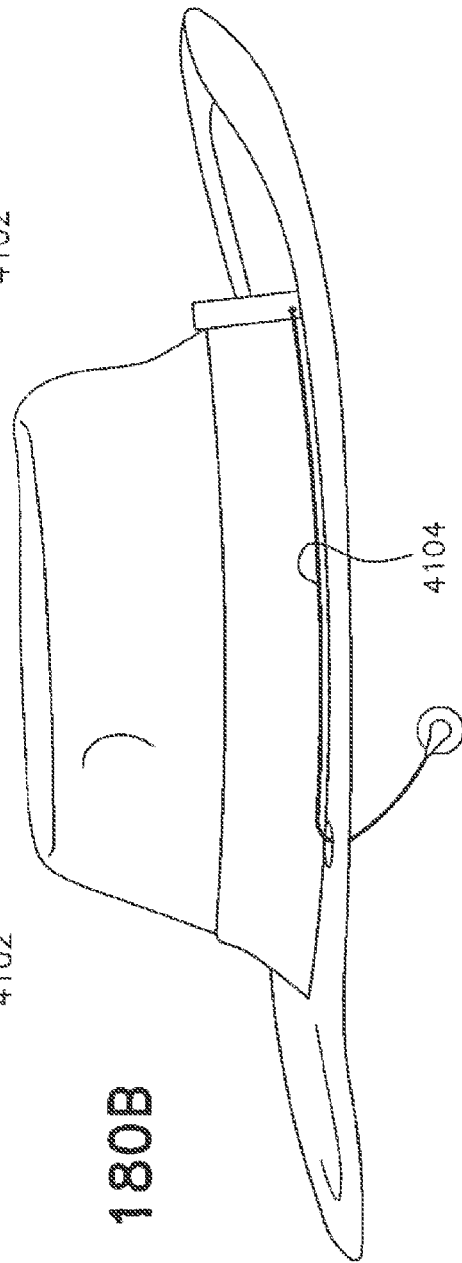

FIG. 180B

FIG. 181

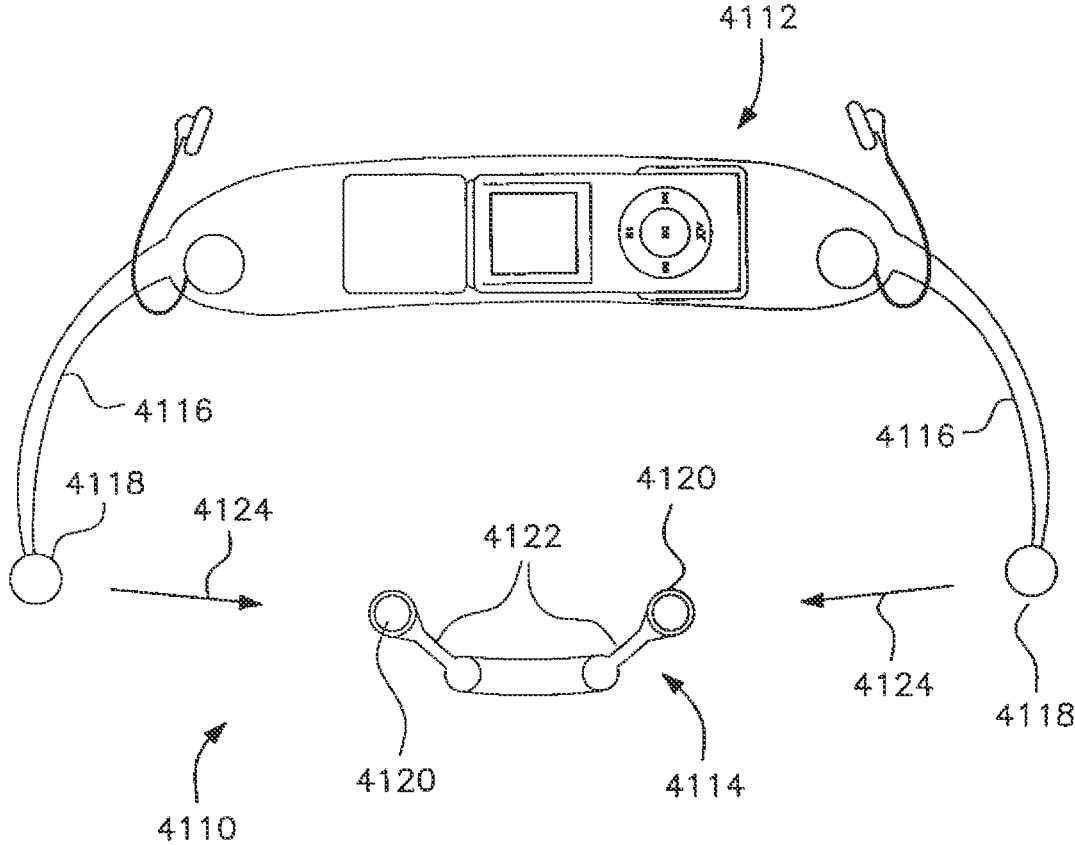

FIG. 182A

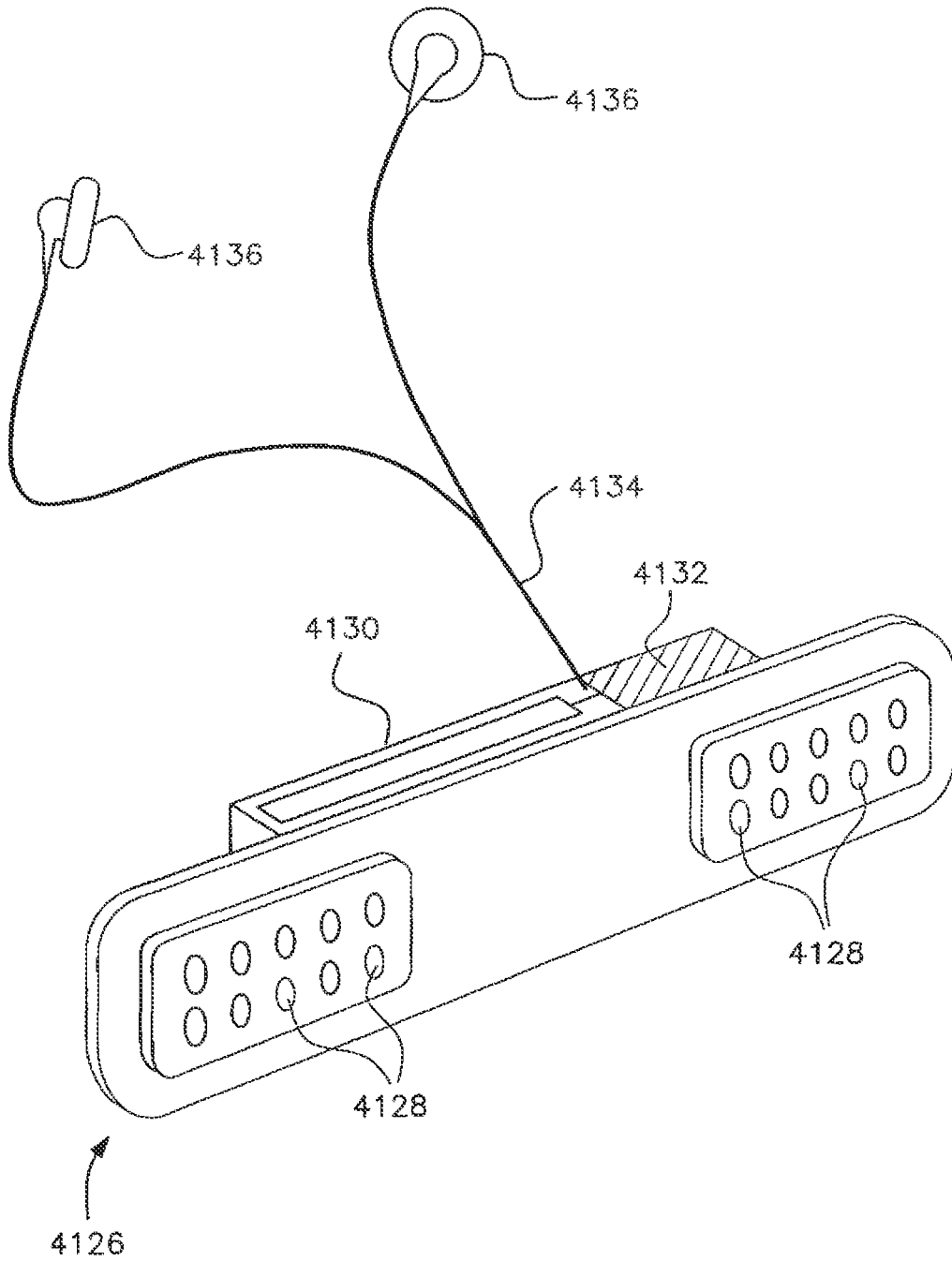

FIG. 182B

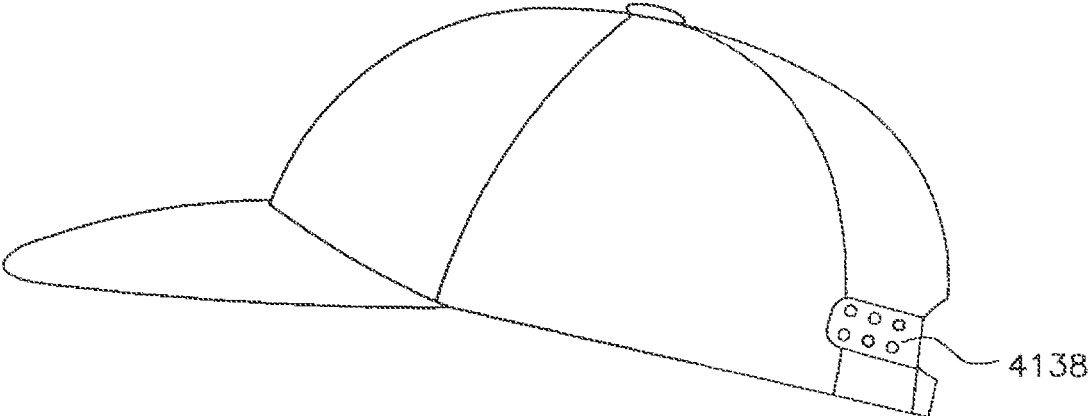

FIG. 182C

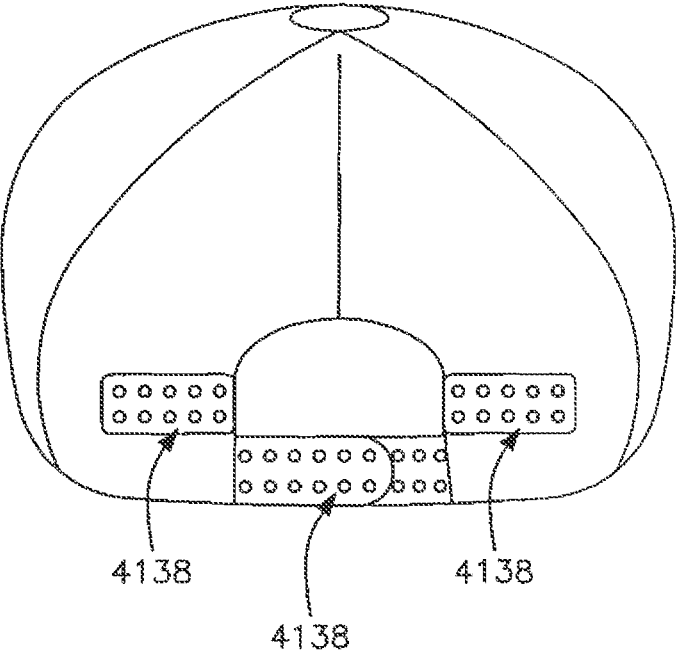

FIG. 182D

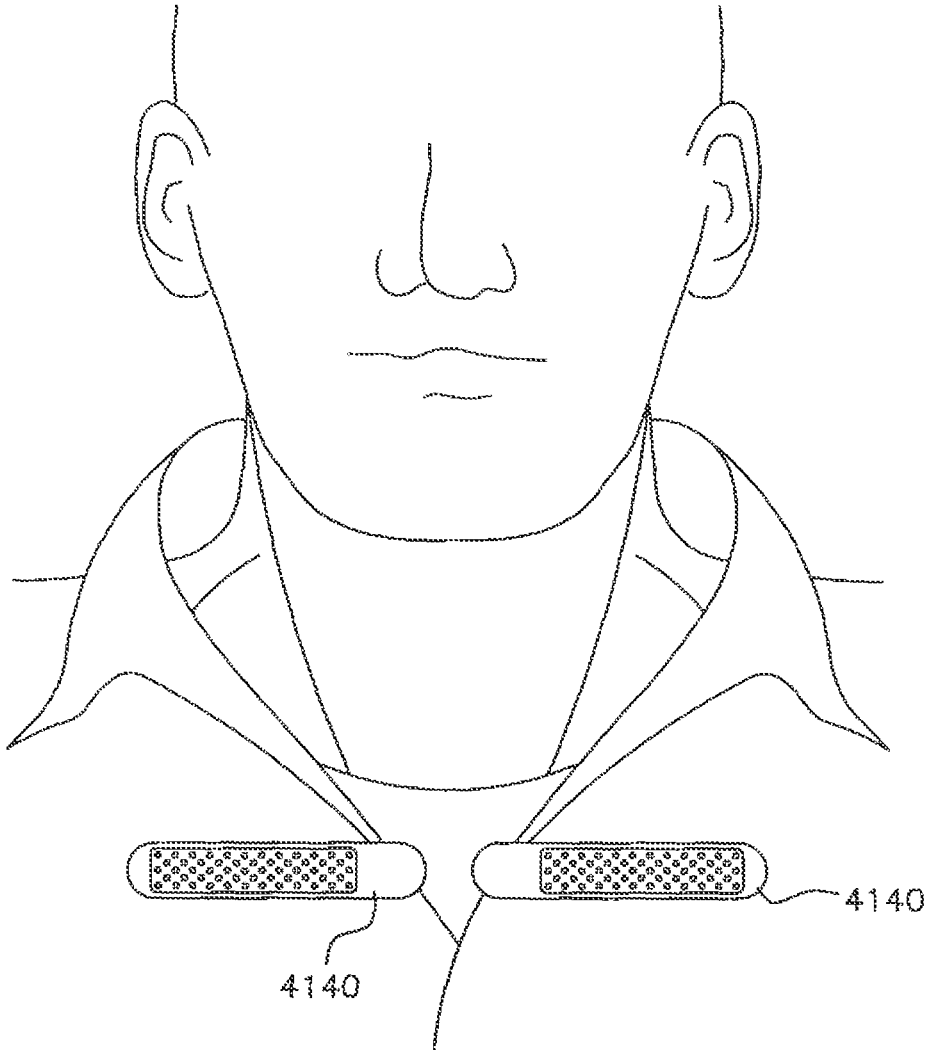

FIG. 182E

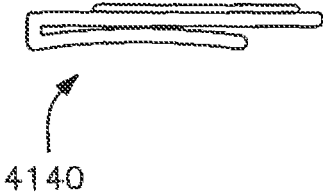

FIG. 182F

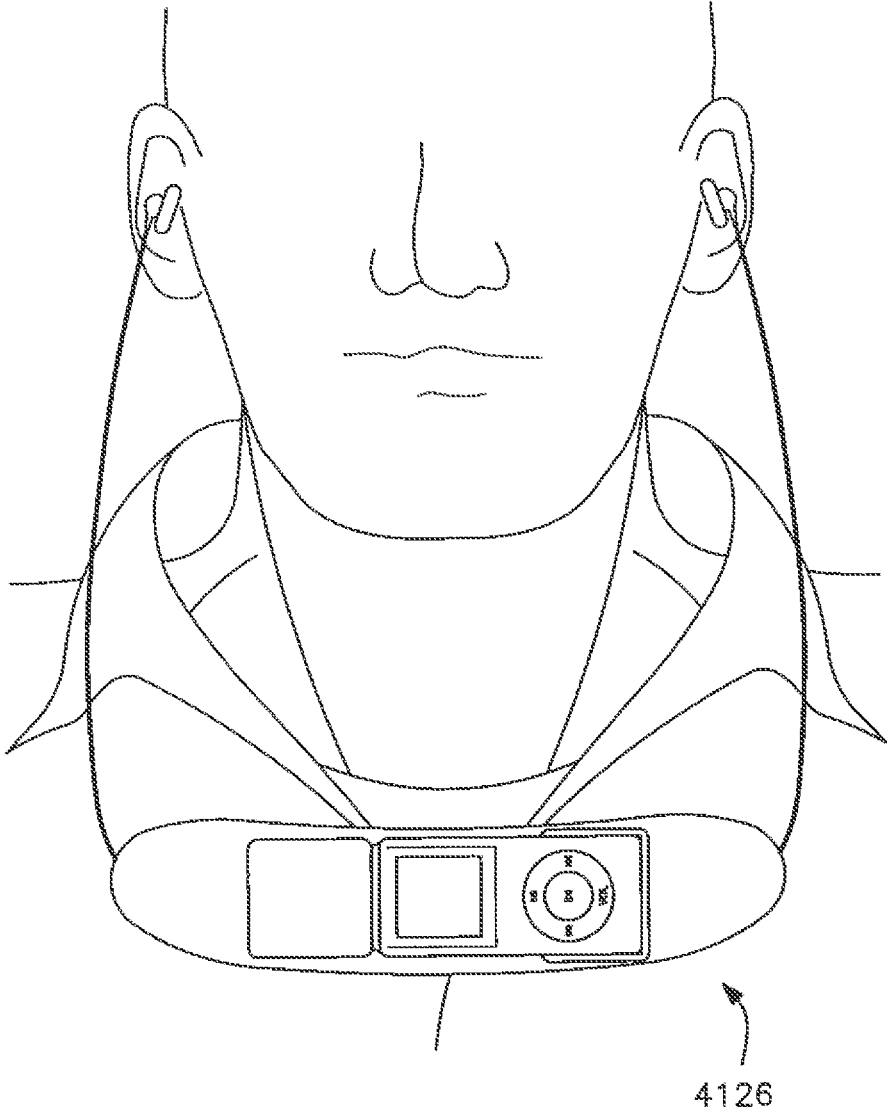

FIG. 182G

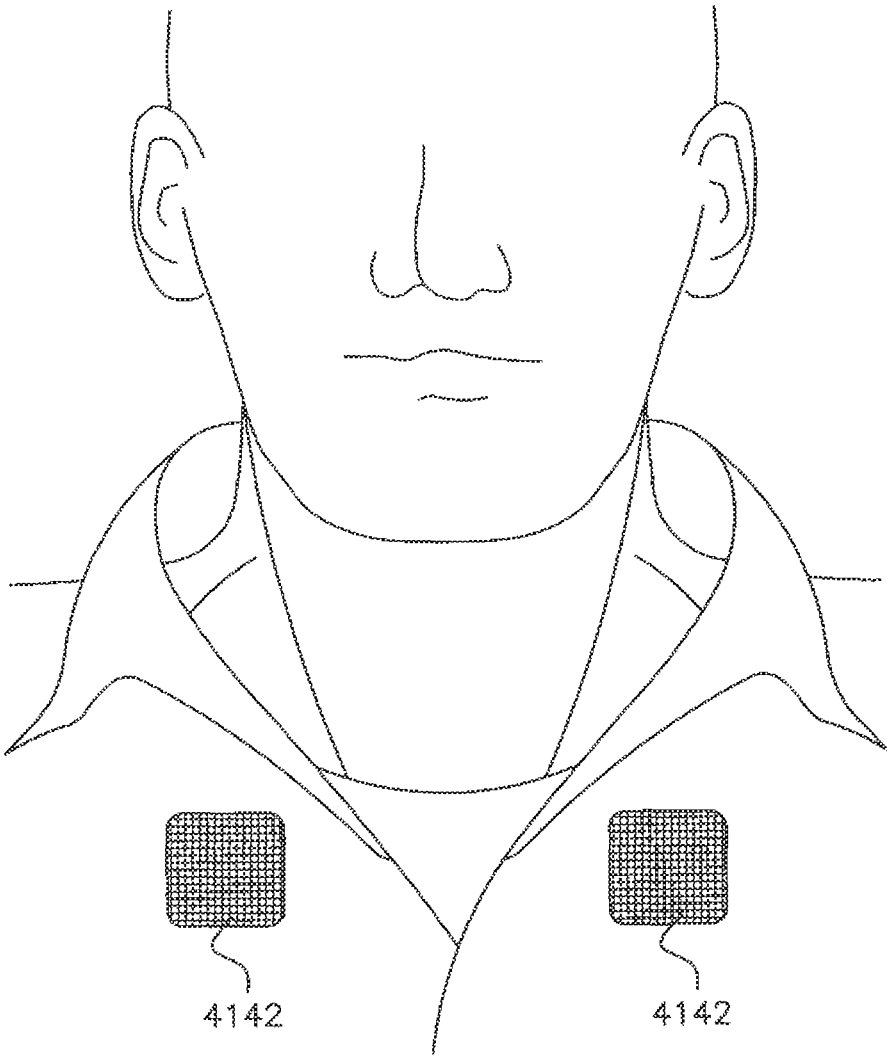

FIG. 182H

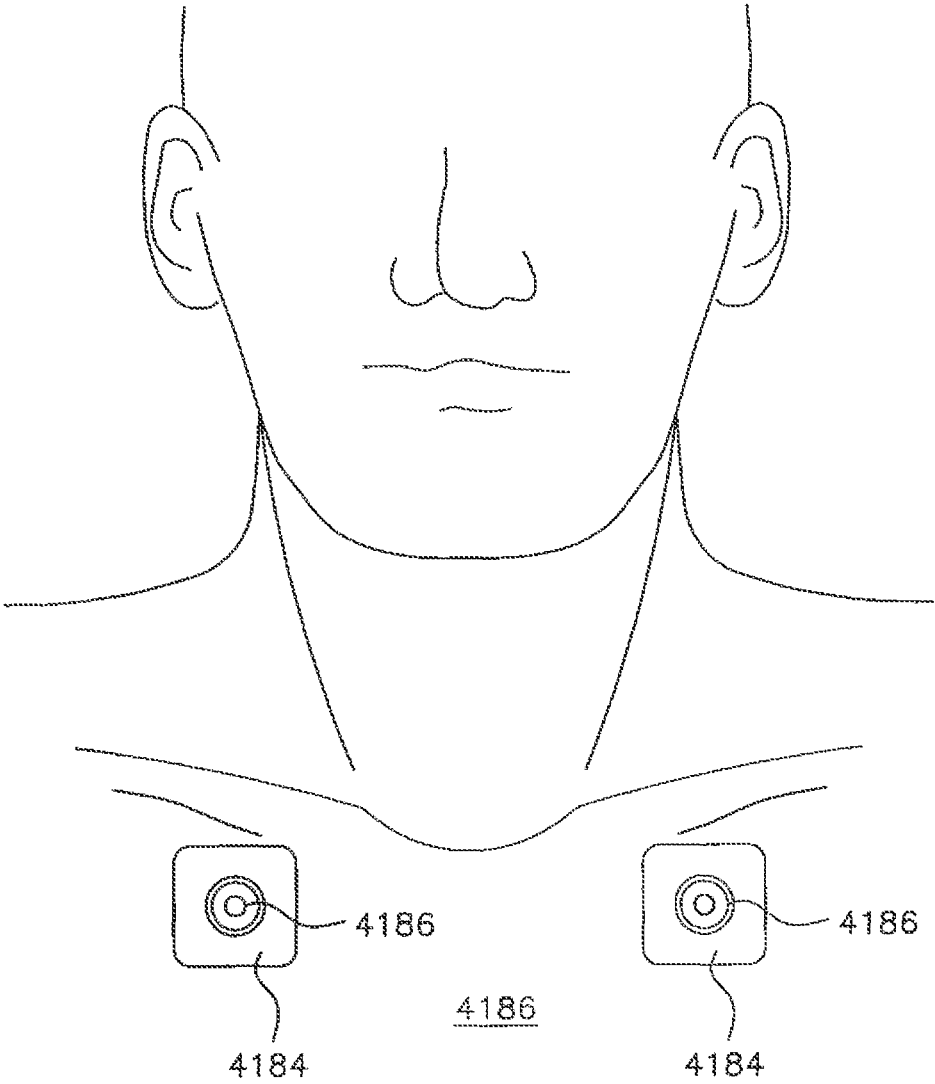

FIG. 182J

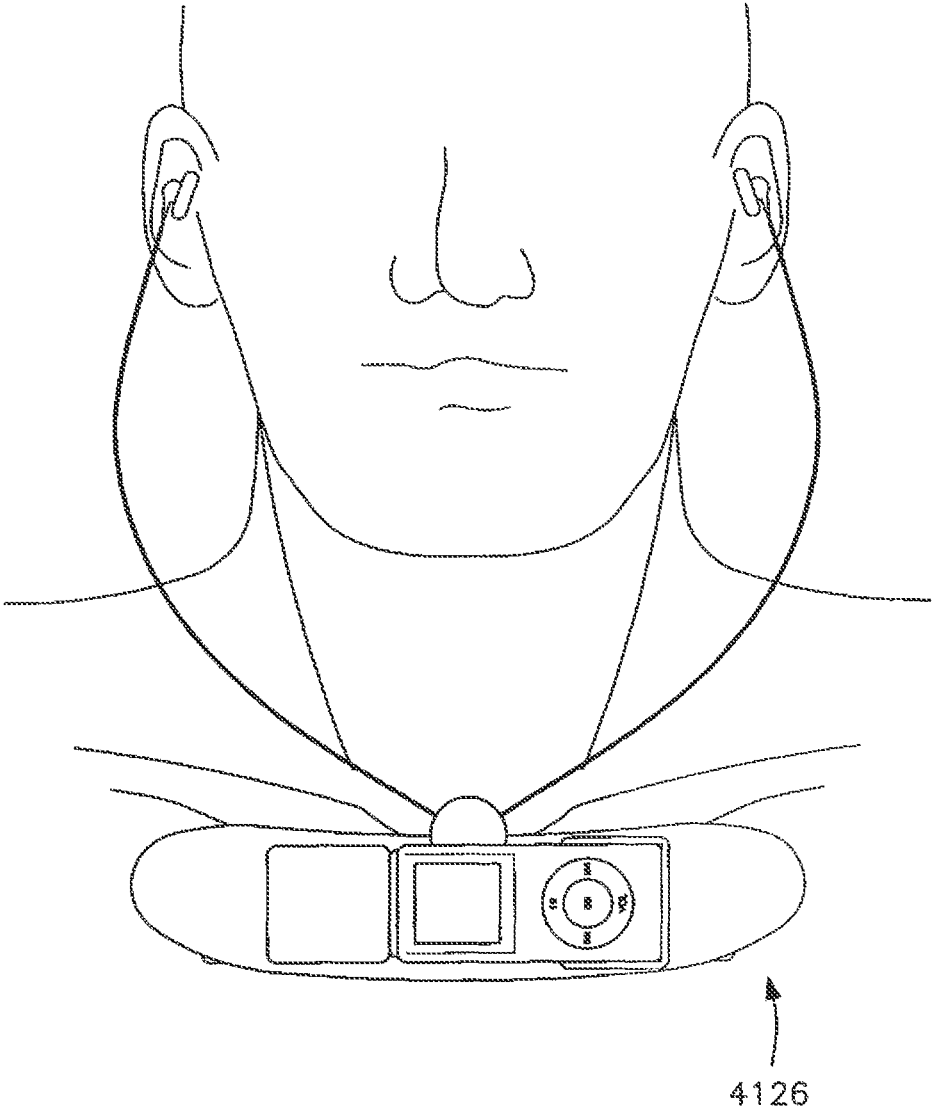

FIG. 183A

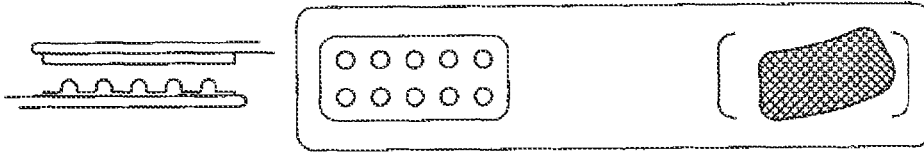

FIG. 183B

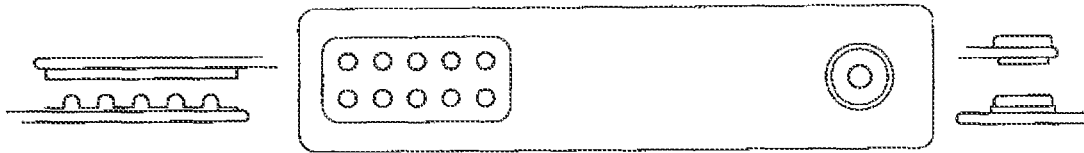

FIG. 183C

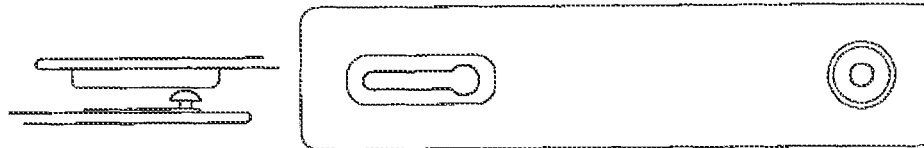

FIG. 183D

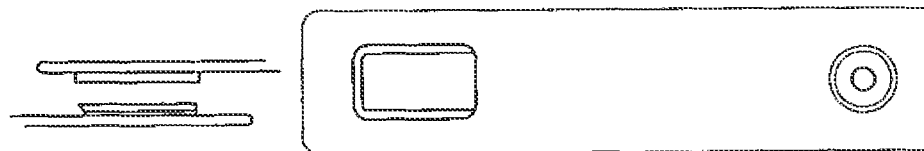

FIG. 183E

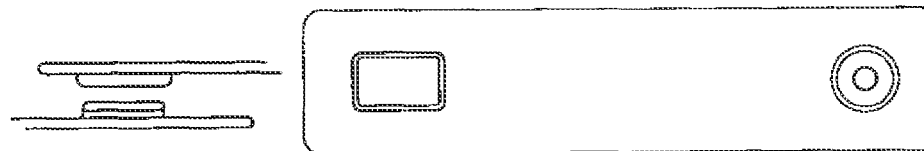

FIG. 184A

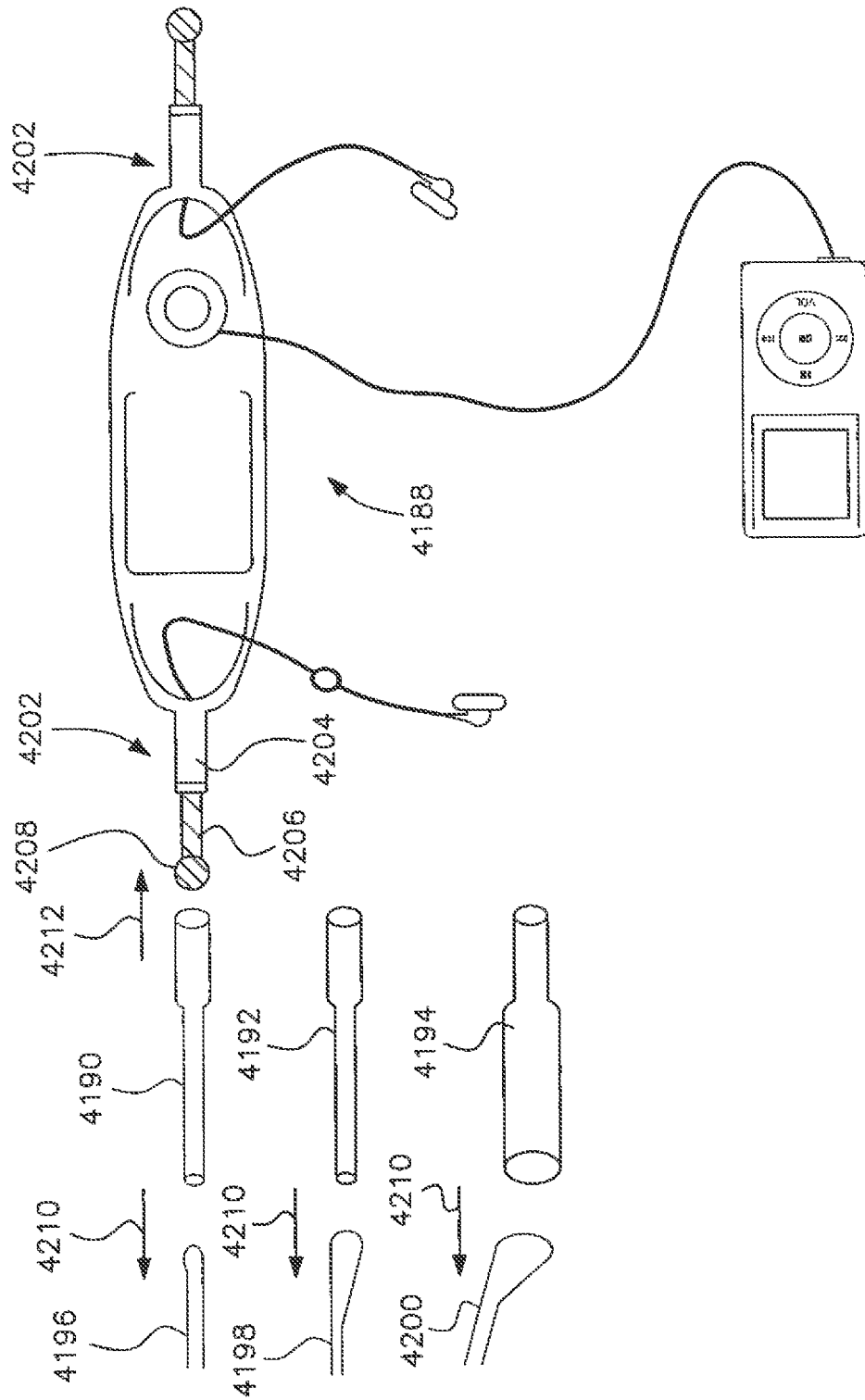

FIG. 184B

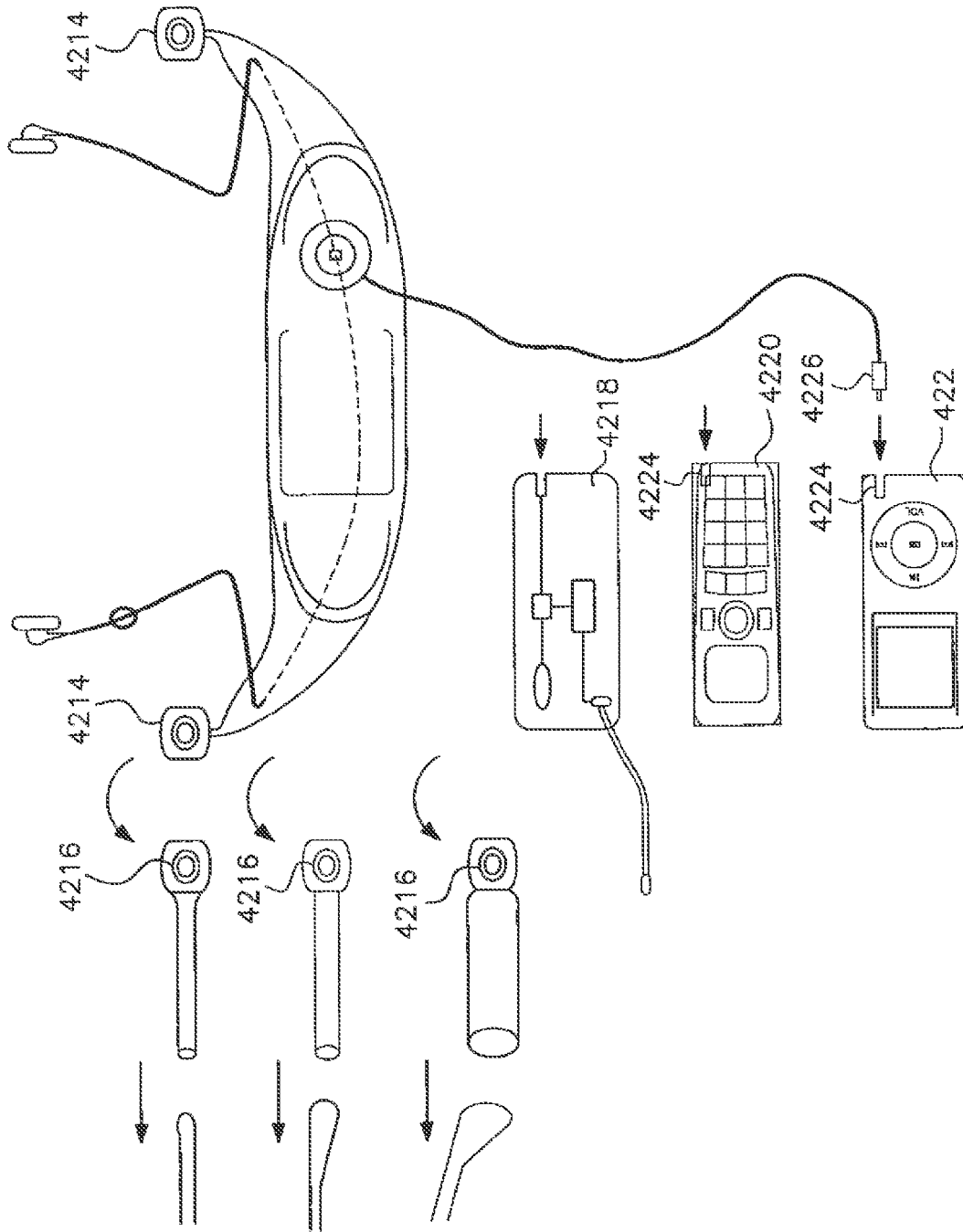

FIG. 184C

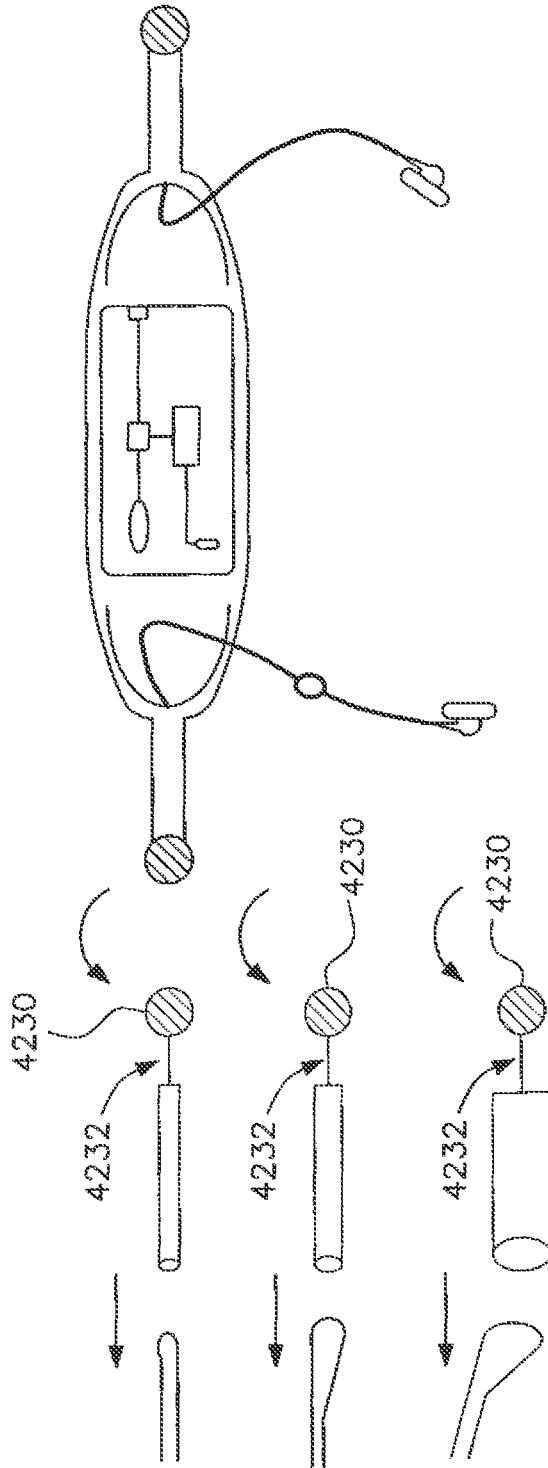

FIG. 184D

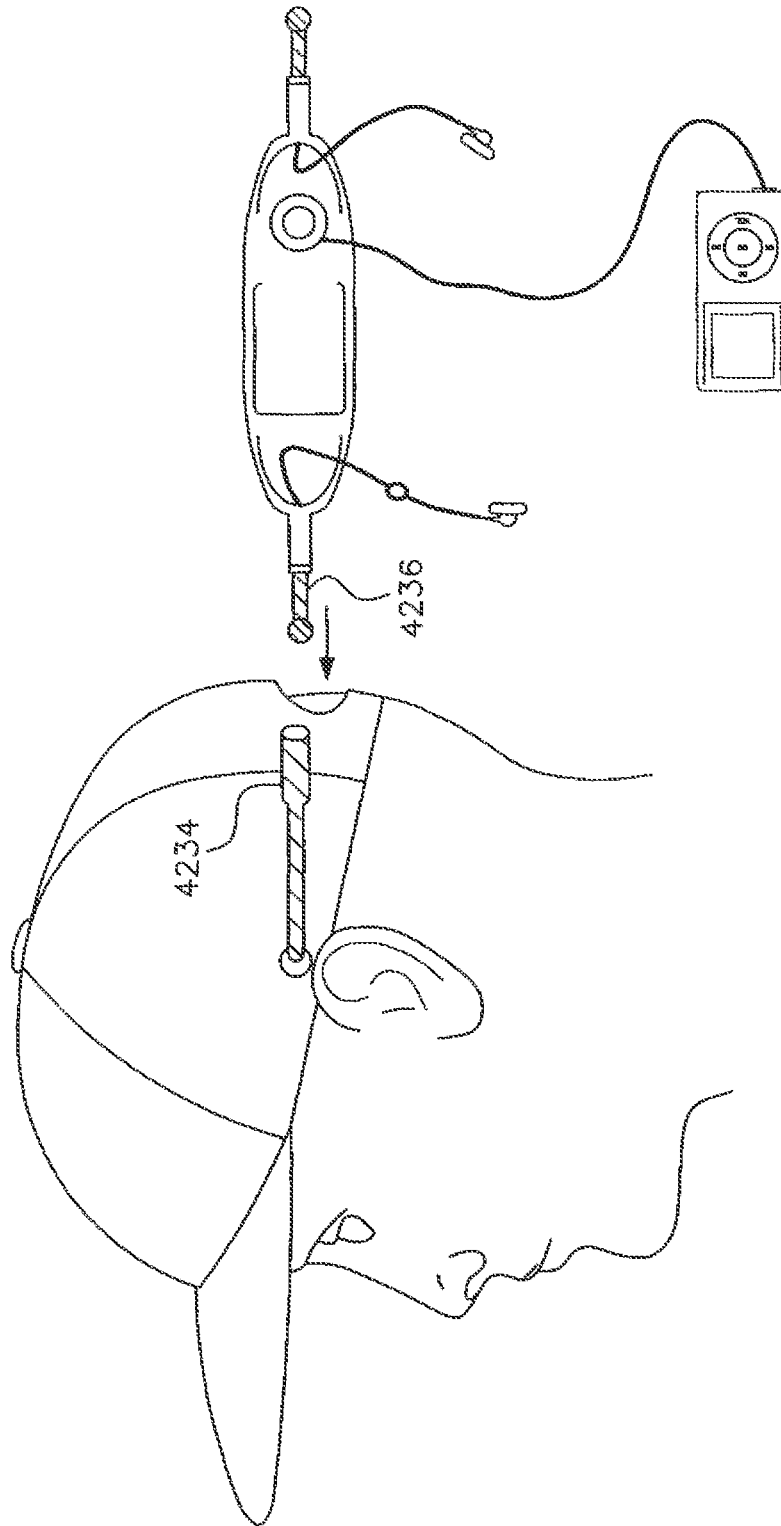

FIG. 184E

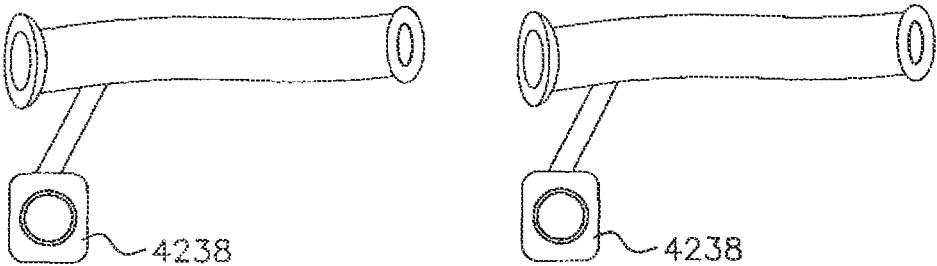

FIG. 184F

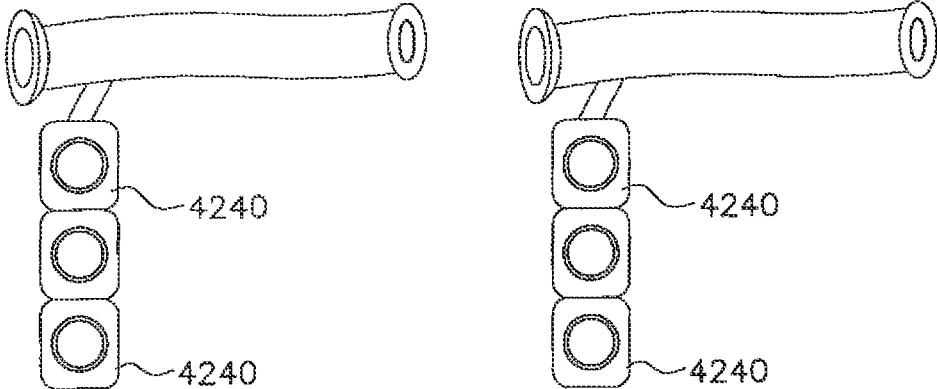

FIG. 185

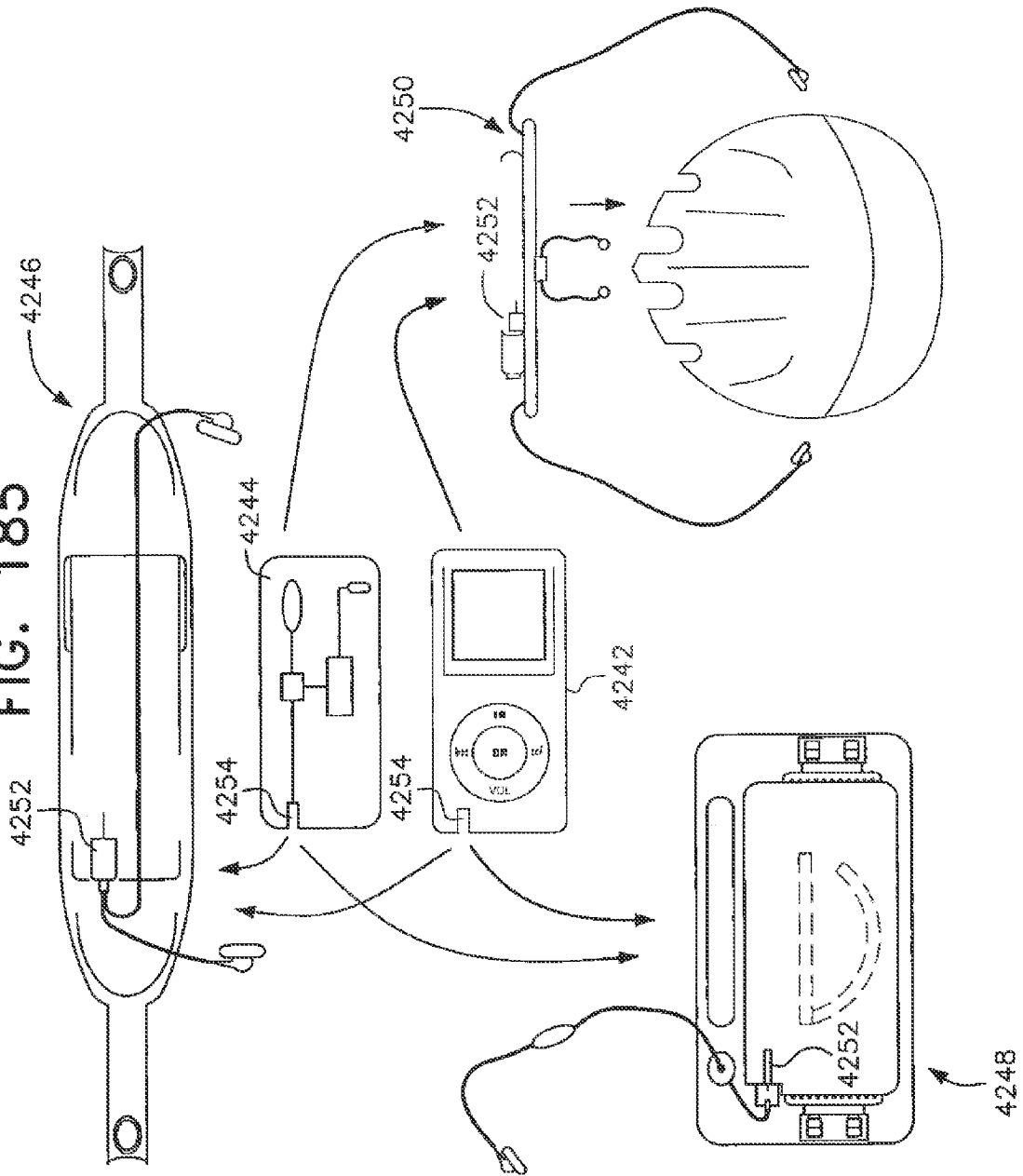

FIG. 186A

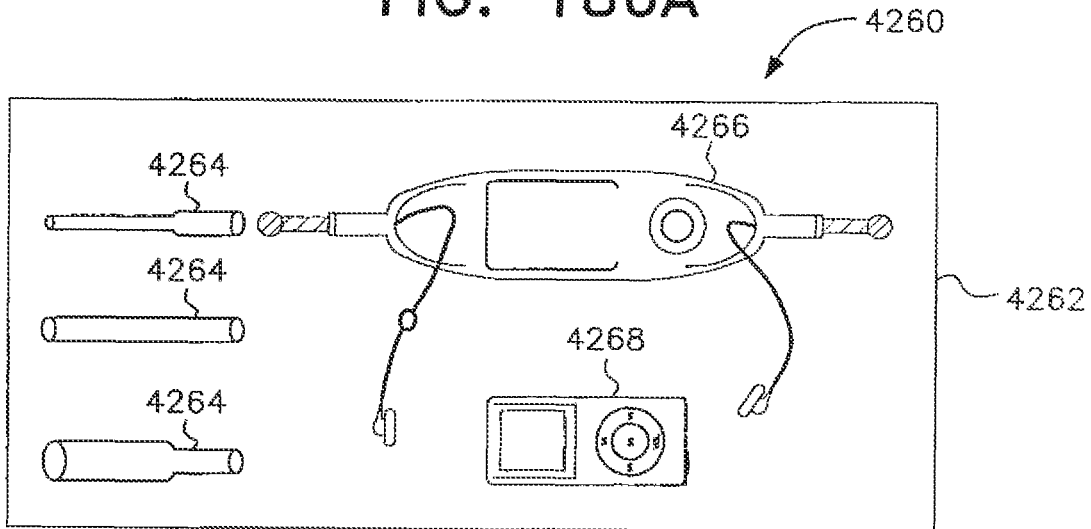

FIG. 186B

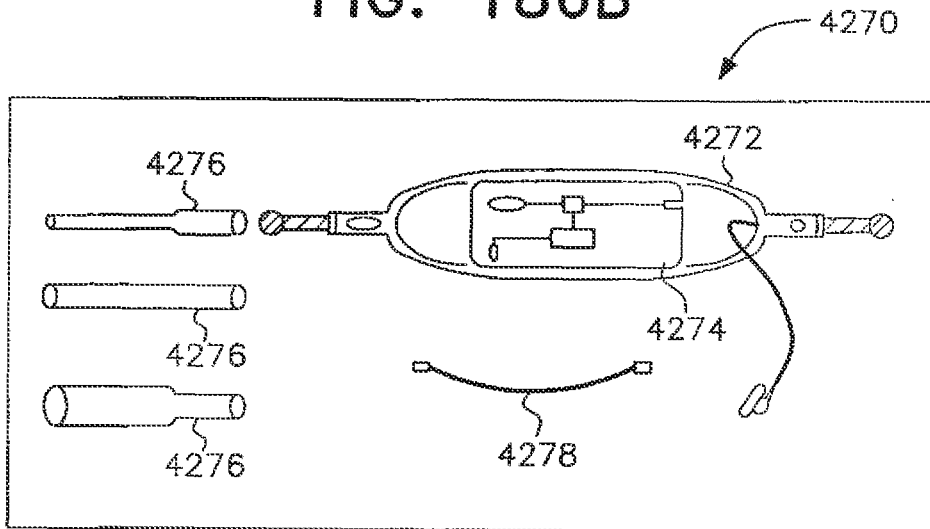

FIG. 187A

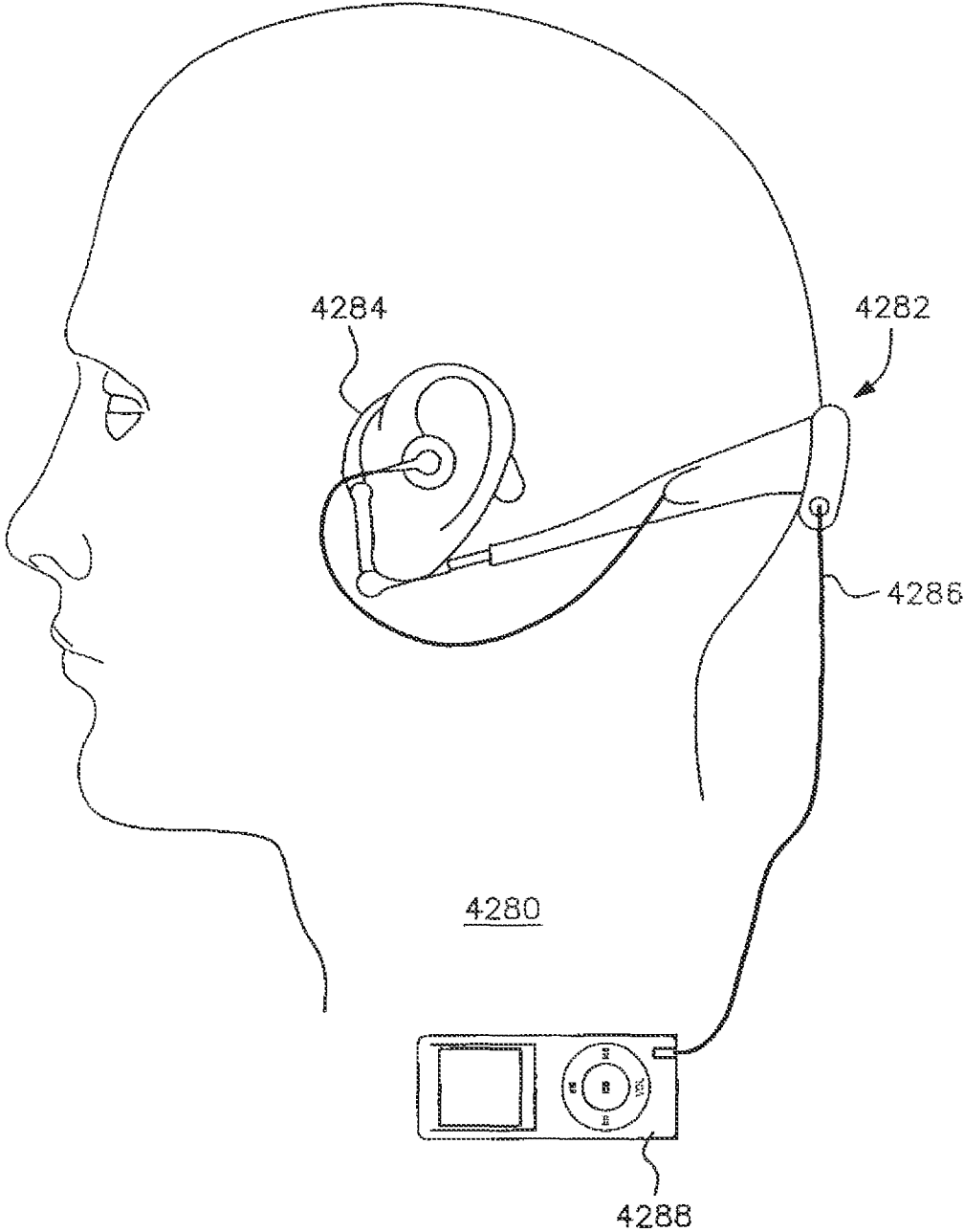

FIG. 187B

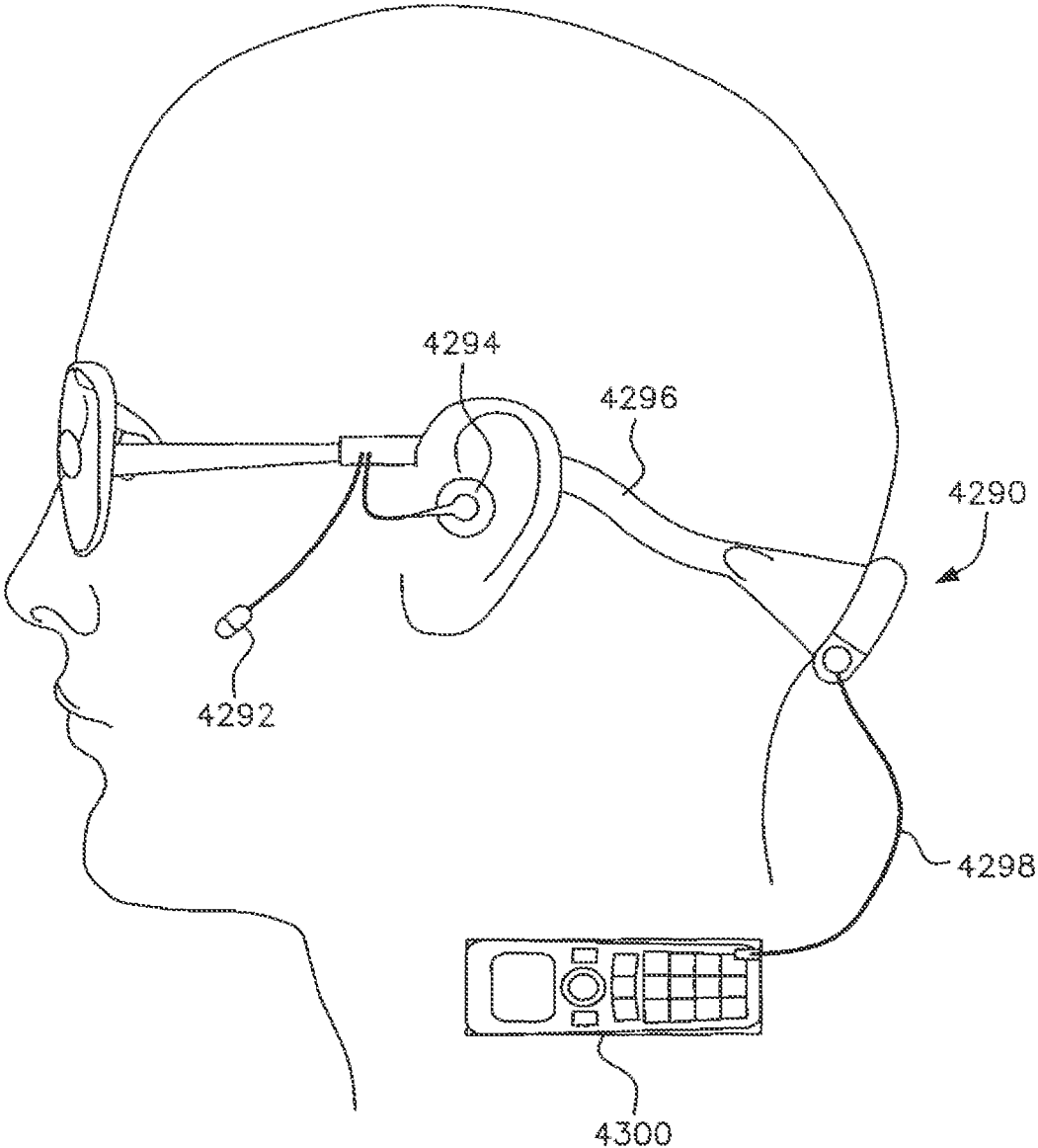

FIG. 188

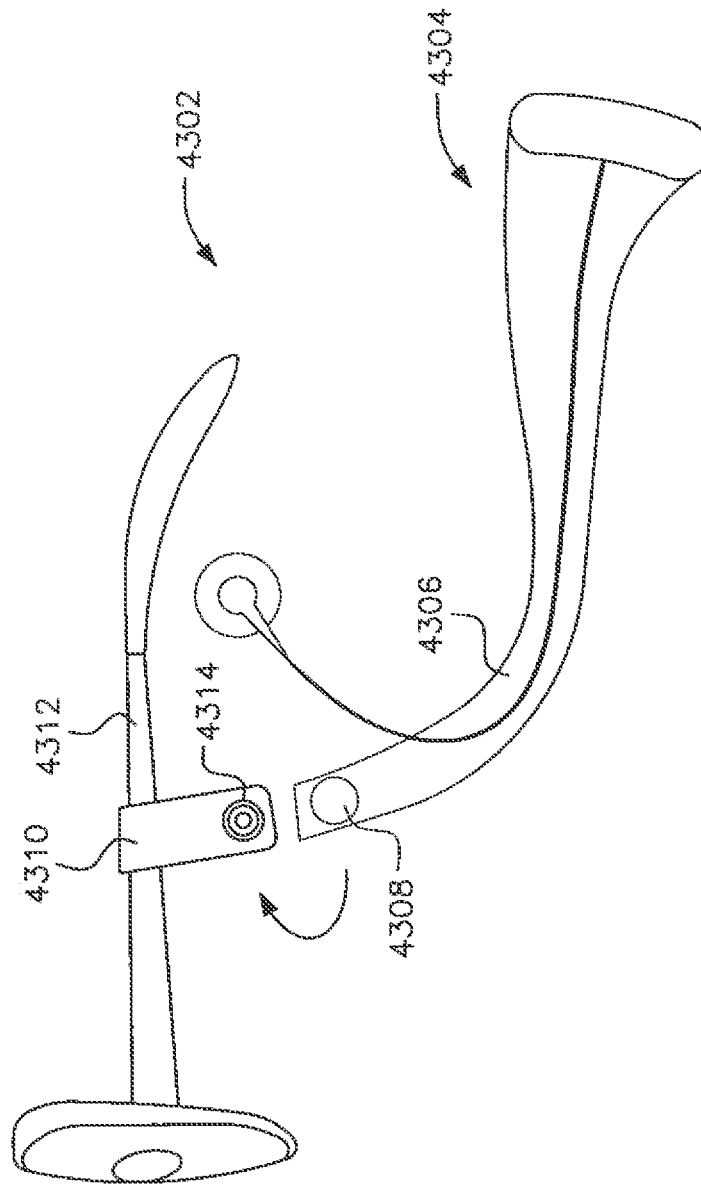

FIG. 188A

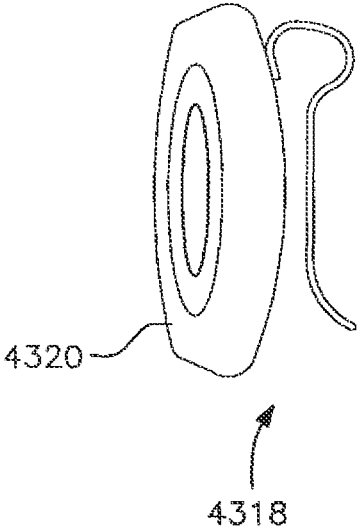

FIG. 188B

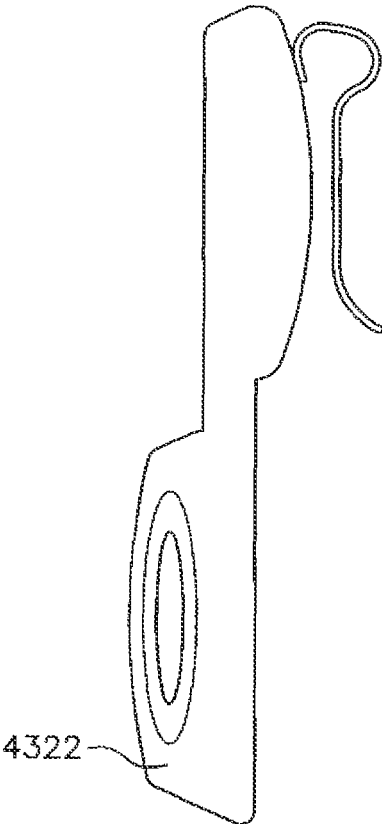

FIG. 189A FIG. 189B FIG. 189C

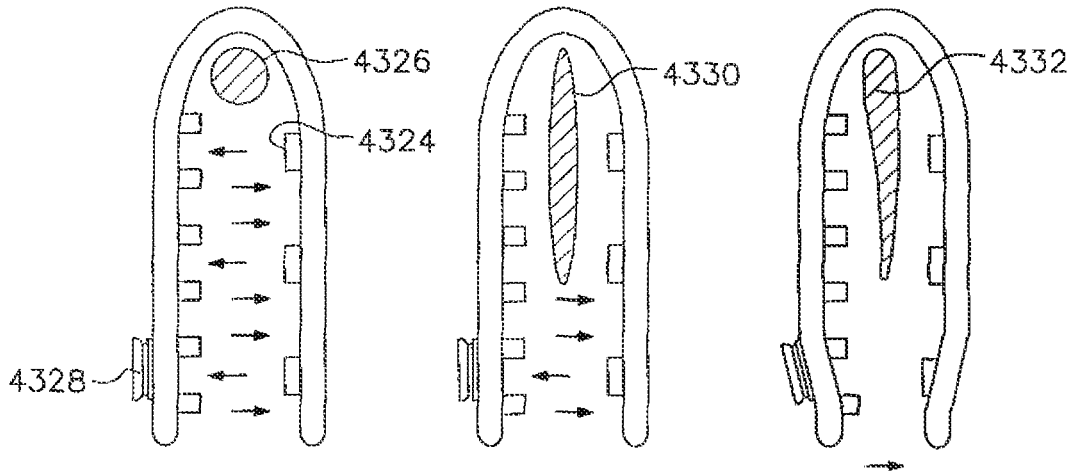

FIG. 189D FIG. 189E FIG. 189F

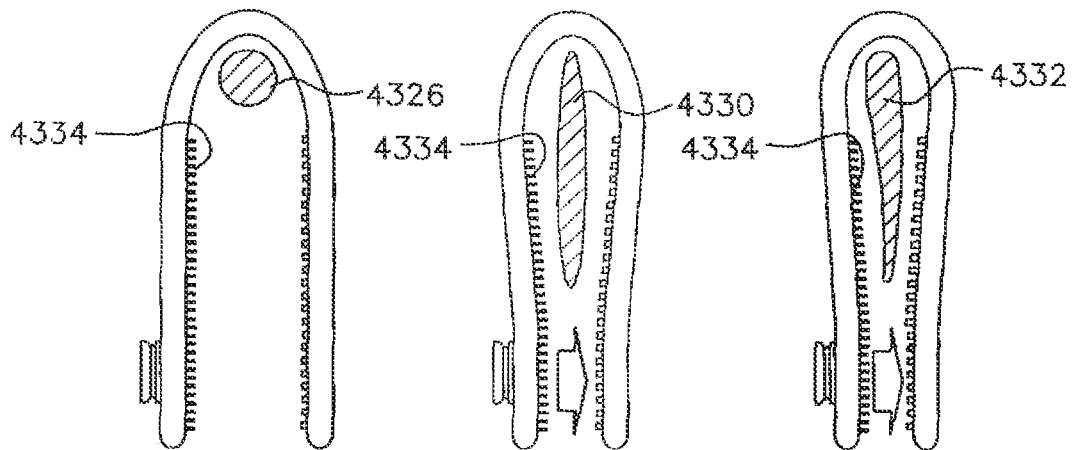

FIG. 189G FIG. 189H FIG. 189J

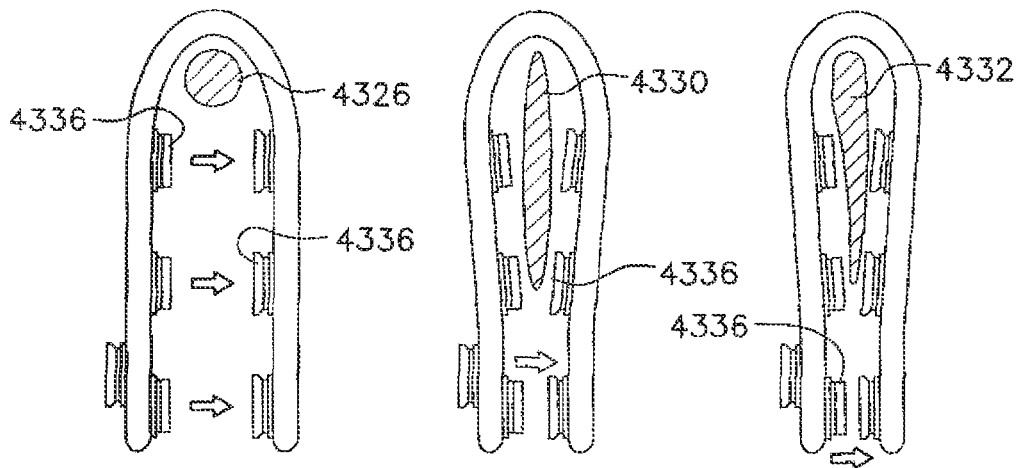

FIG. 189K

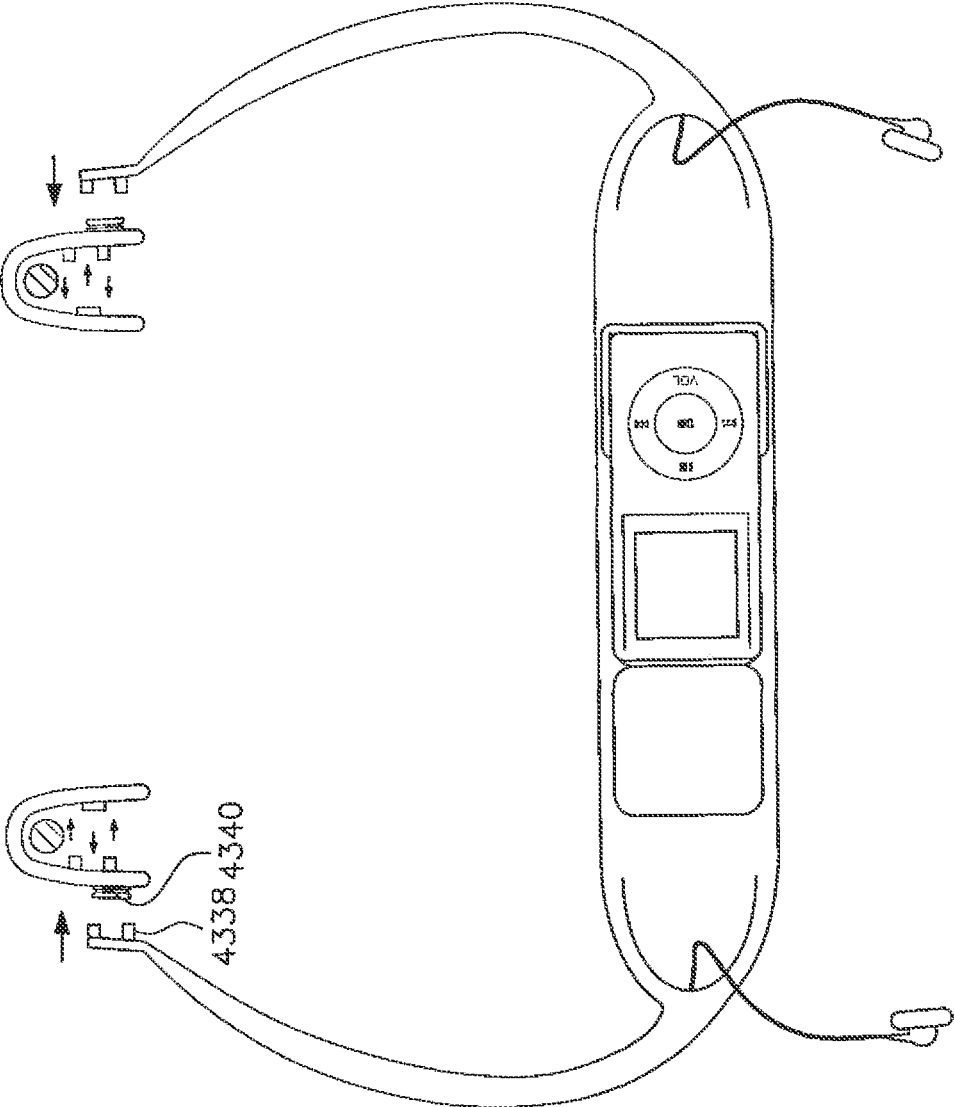

FIG. 190

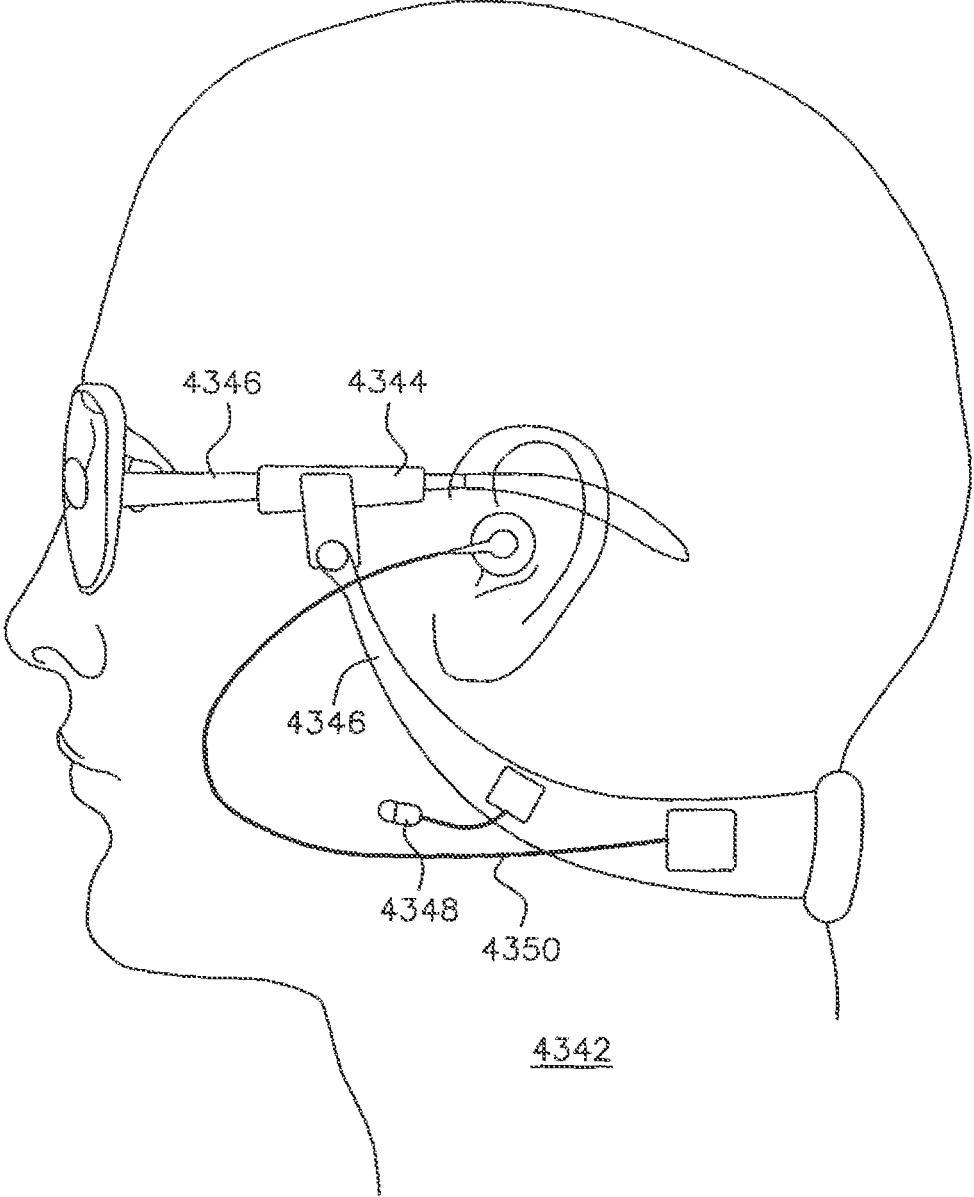

FIG. 190A

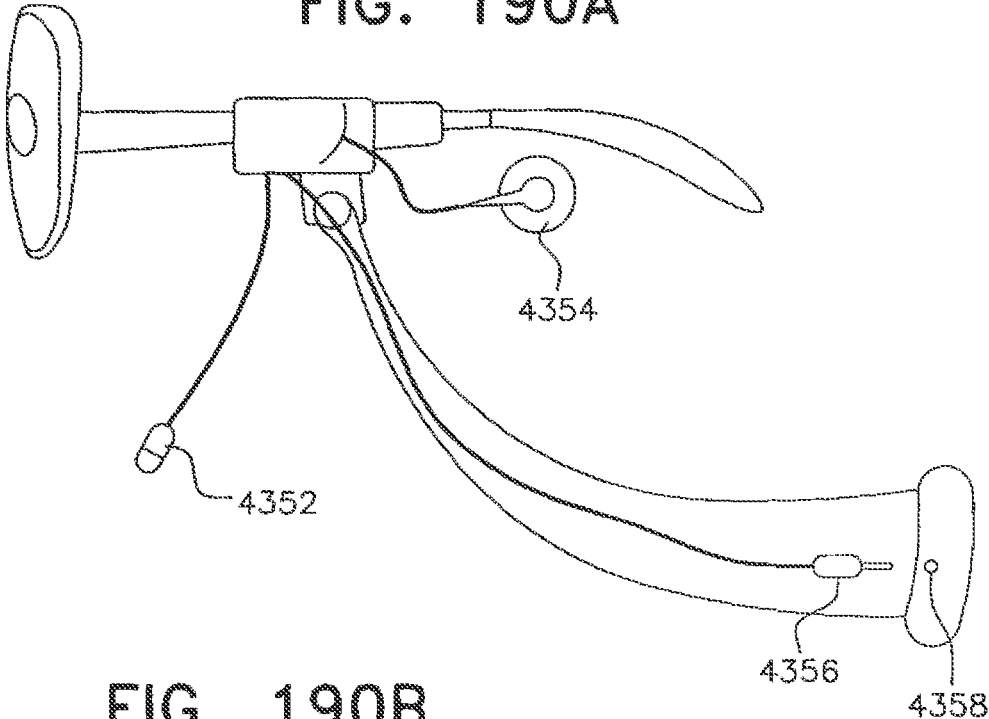

FIG. 190B

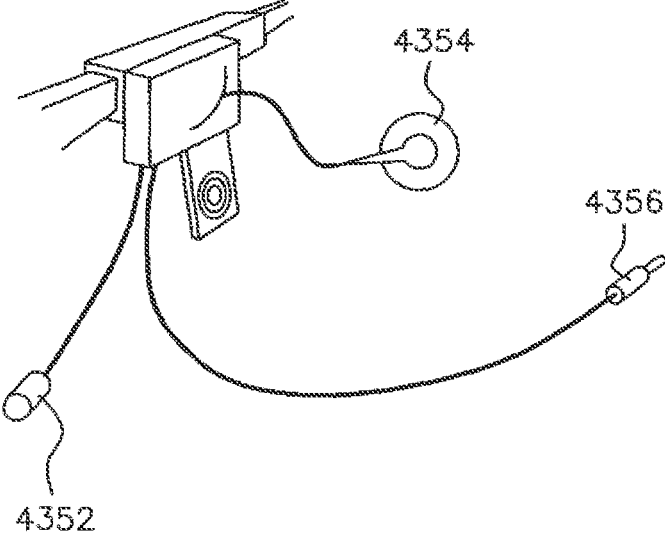

FIG. 191

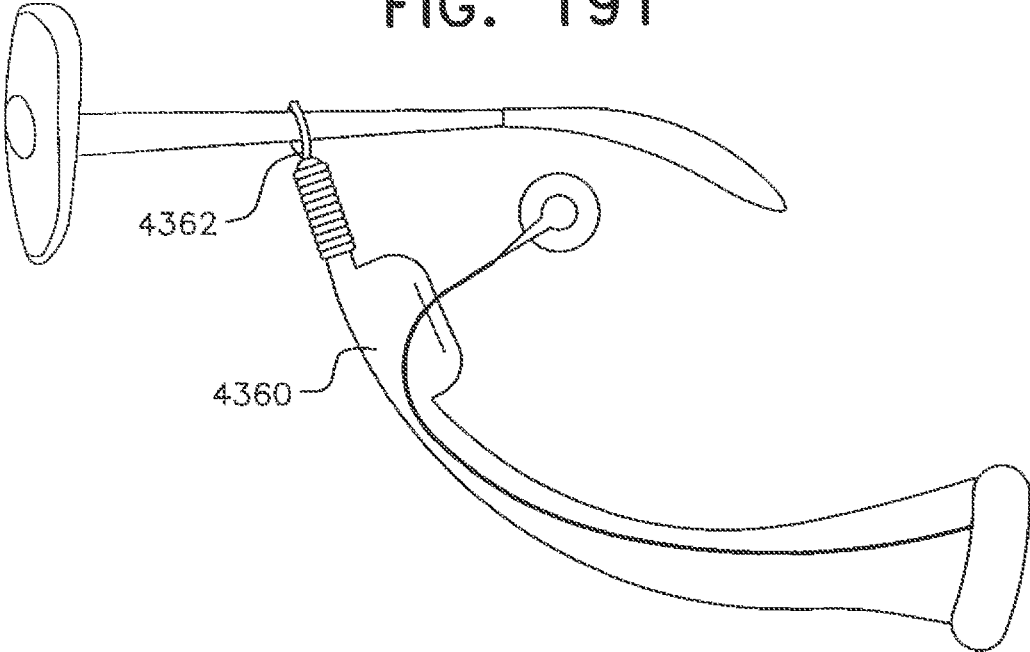

FIG. 191A

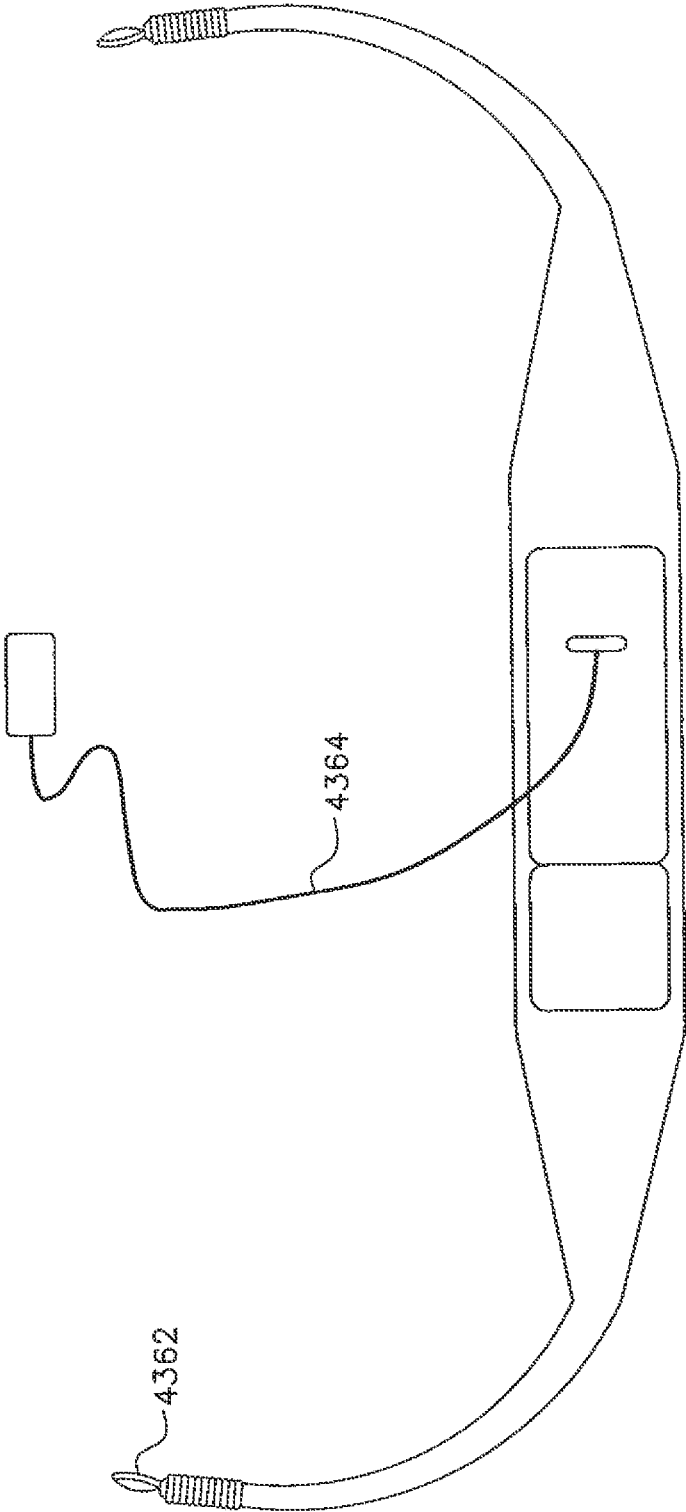

FIG. 191B

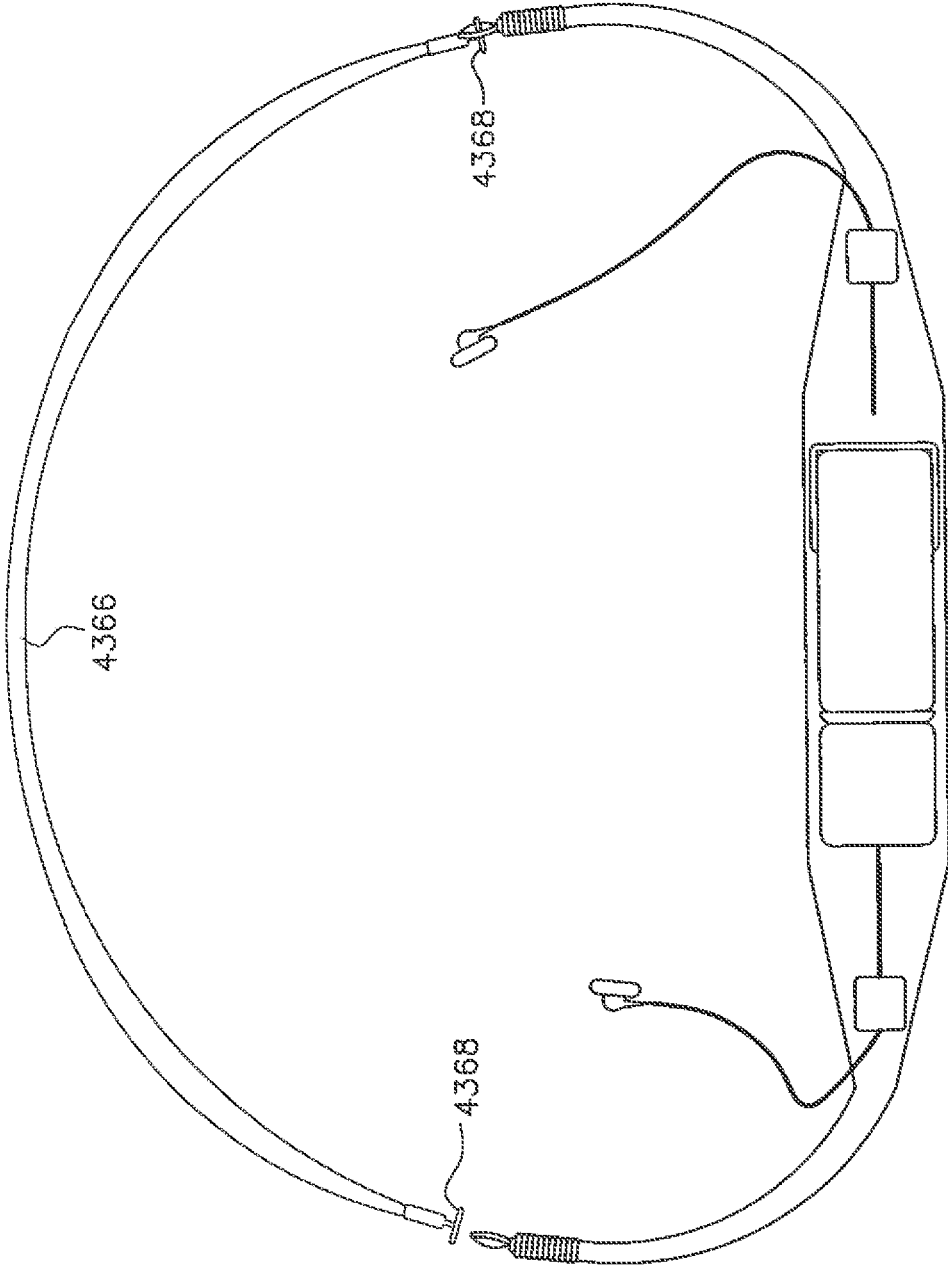

FIG. 192A

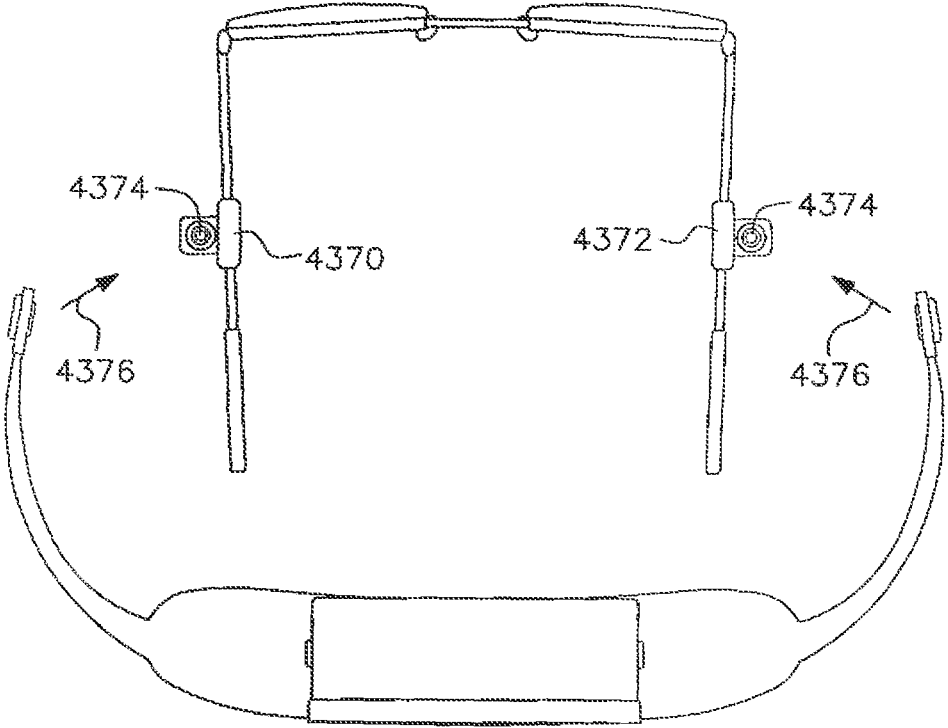

FIG. 192B

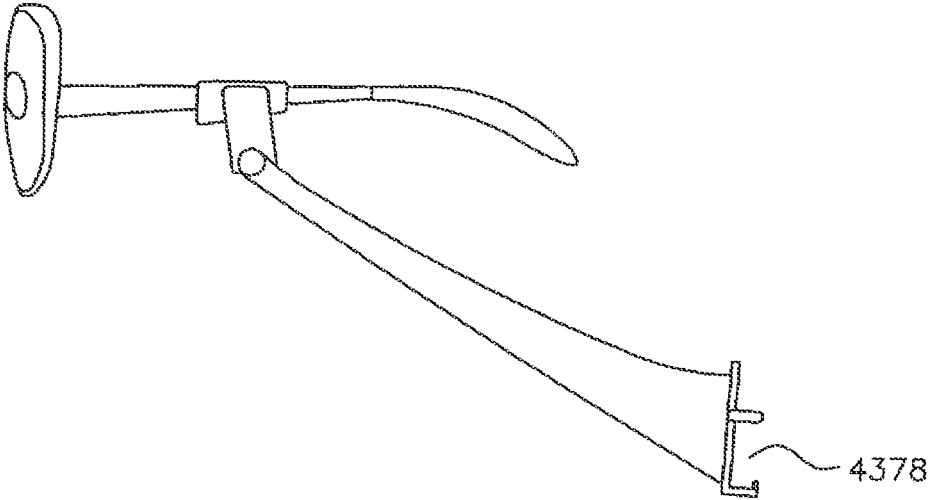

FIG. 192C

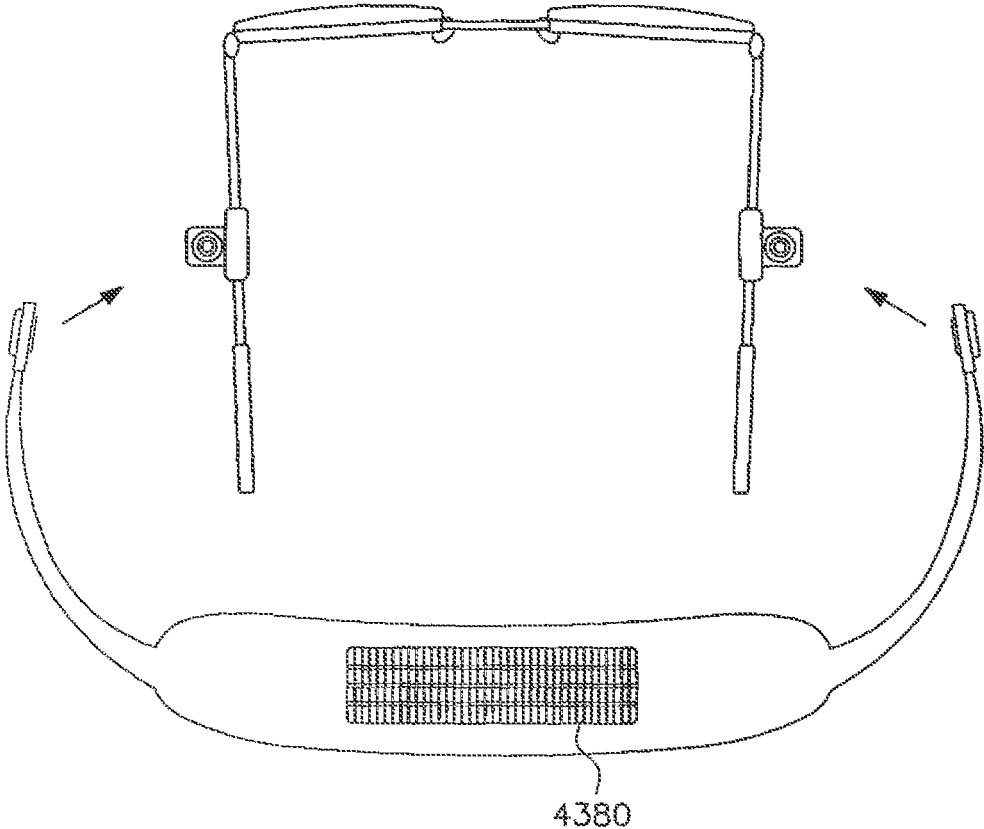

FIG. 192D

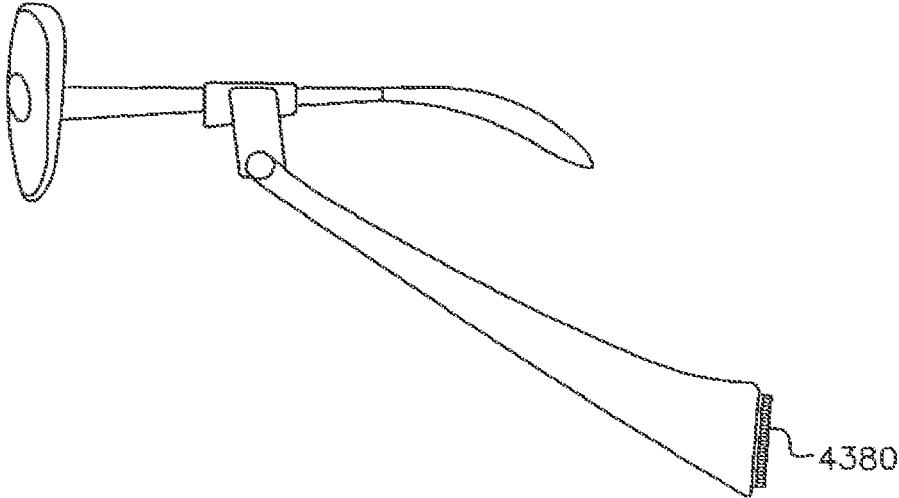

FIG. 192E

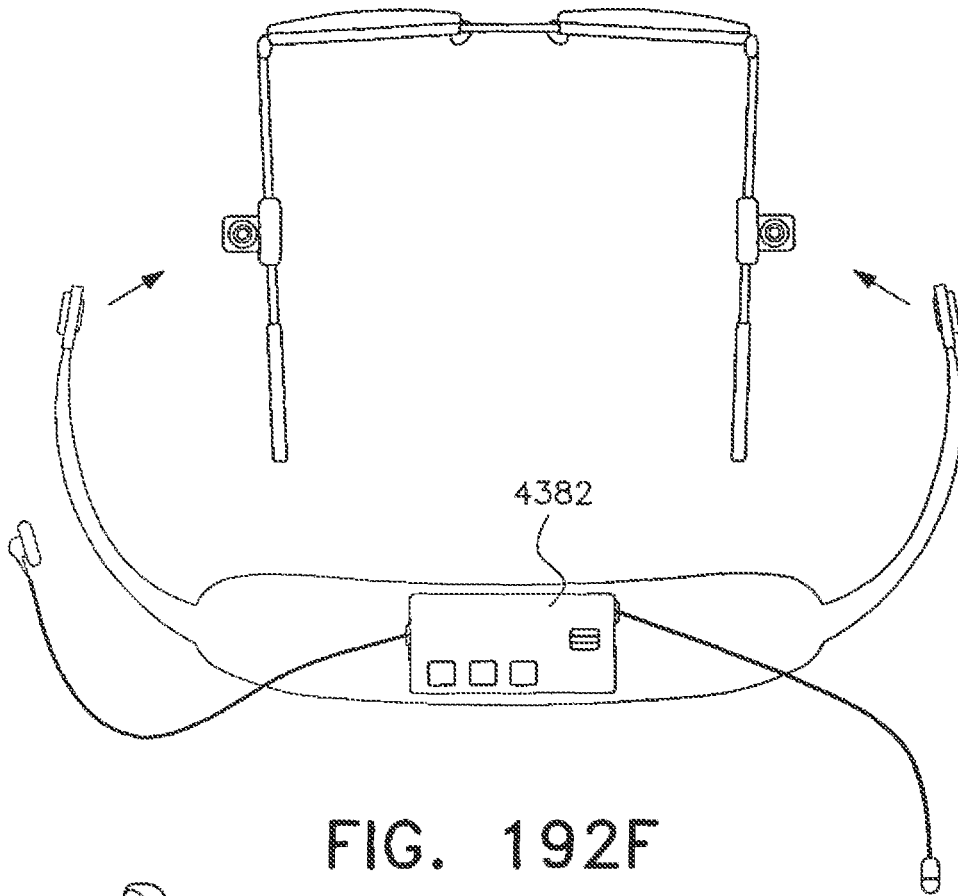

FIG. 192F

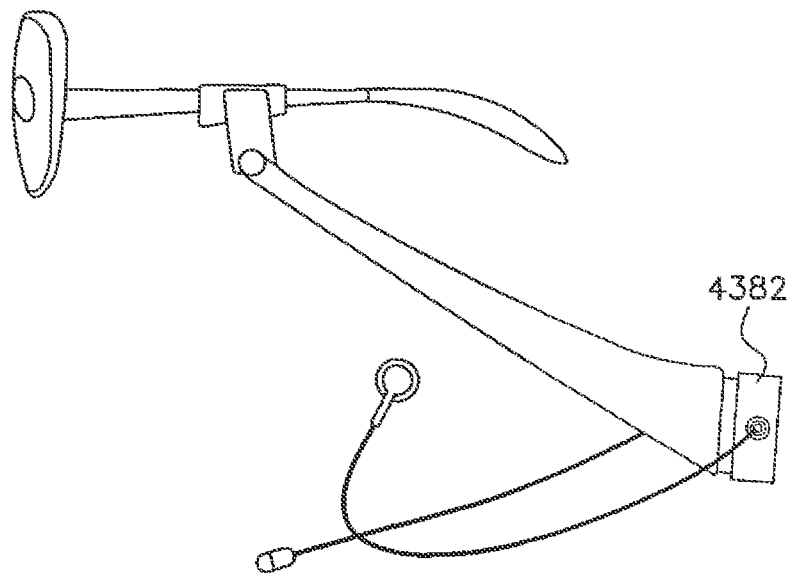

FIG. 192G

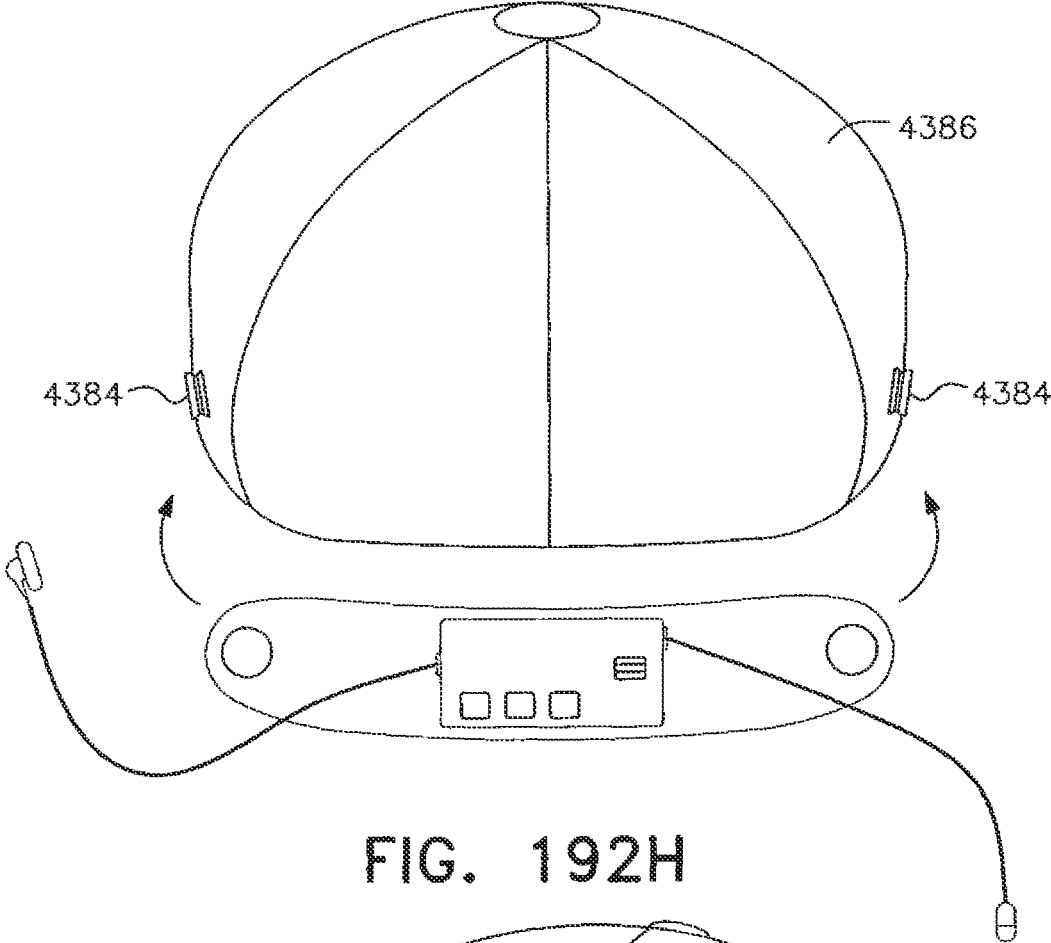

FIG. 192H

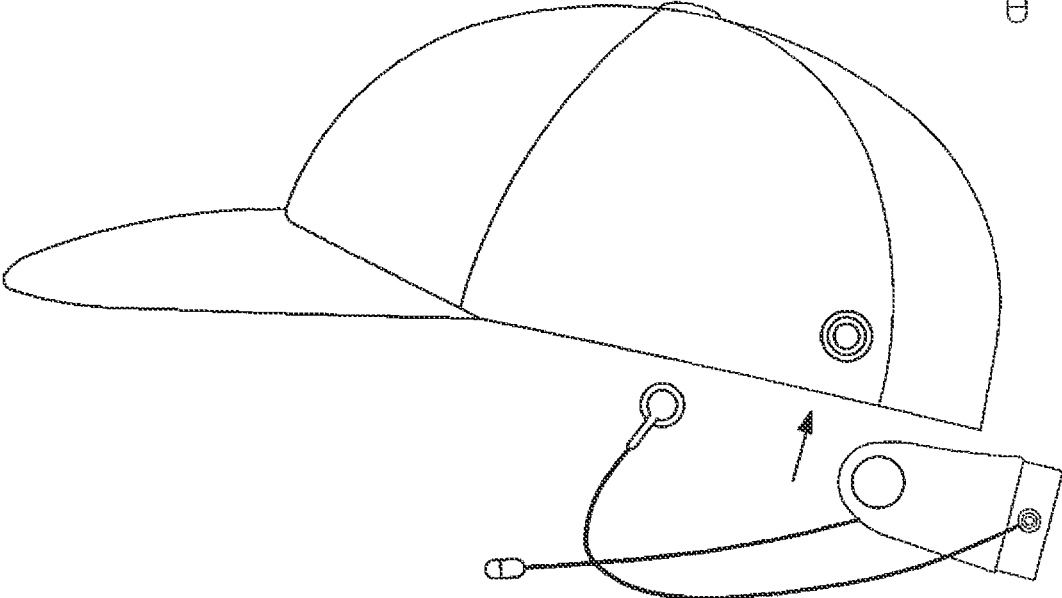

FIG. 192J

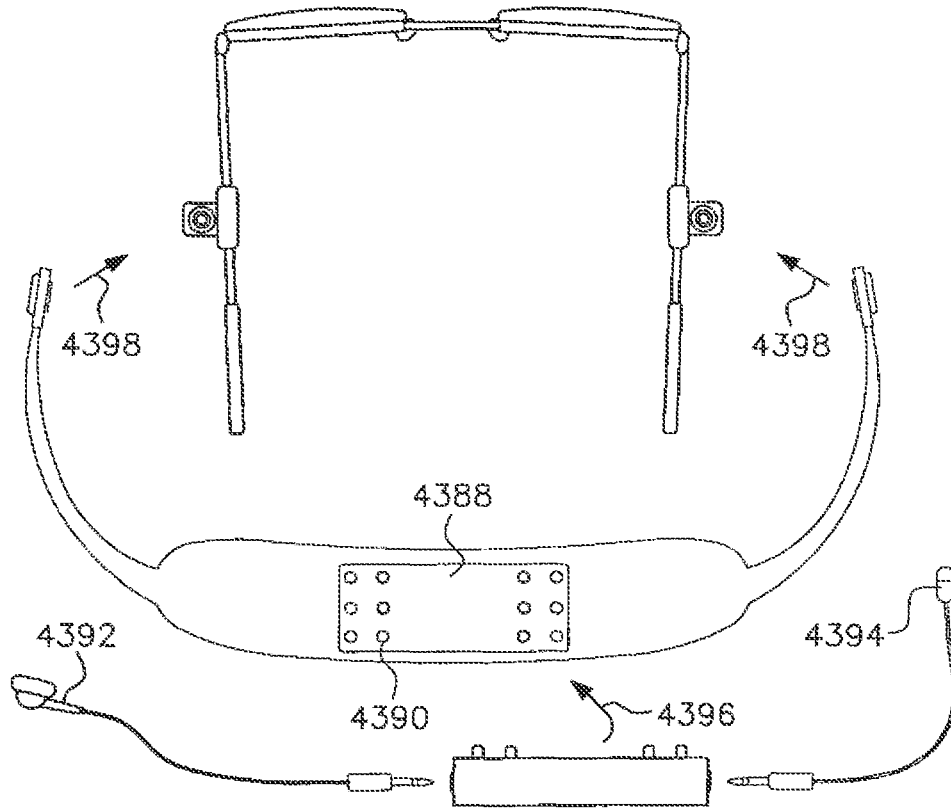

FIG. 192K

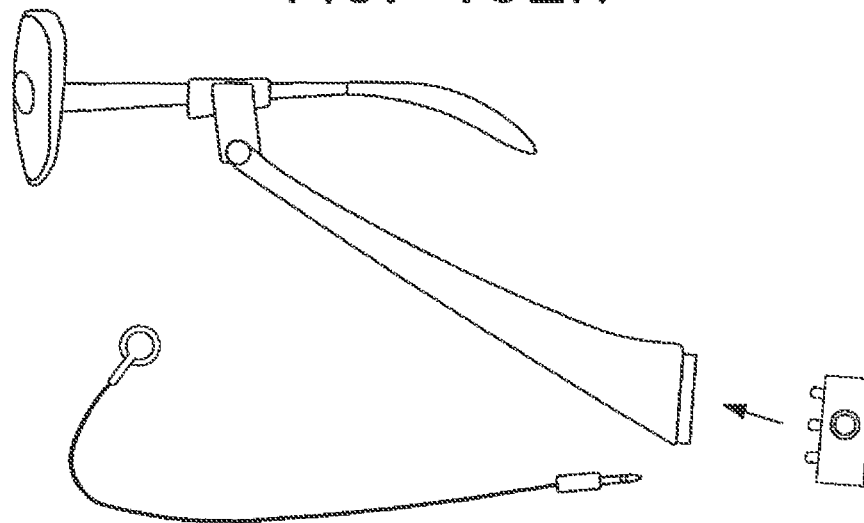

FIG. 192L

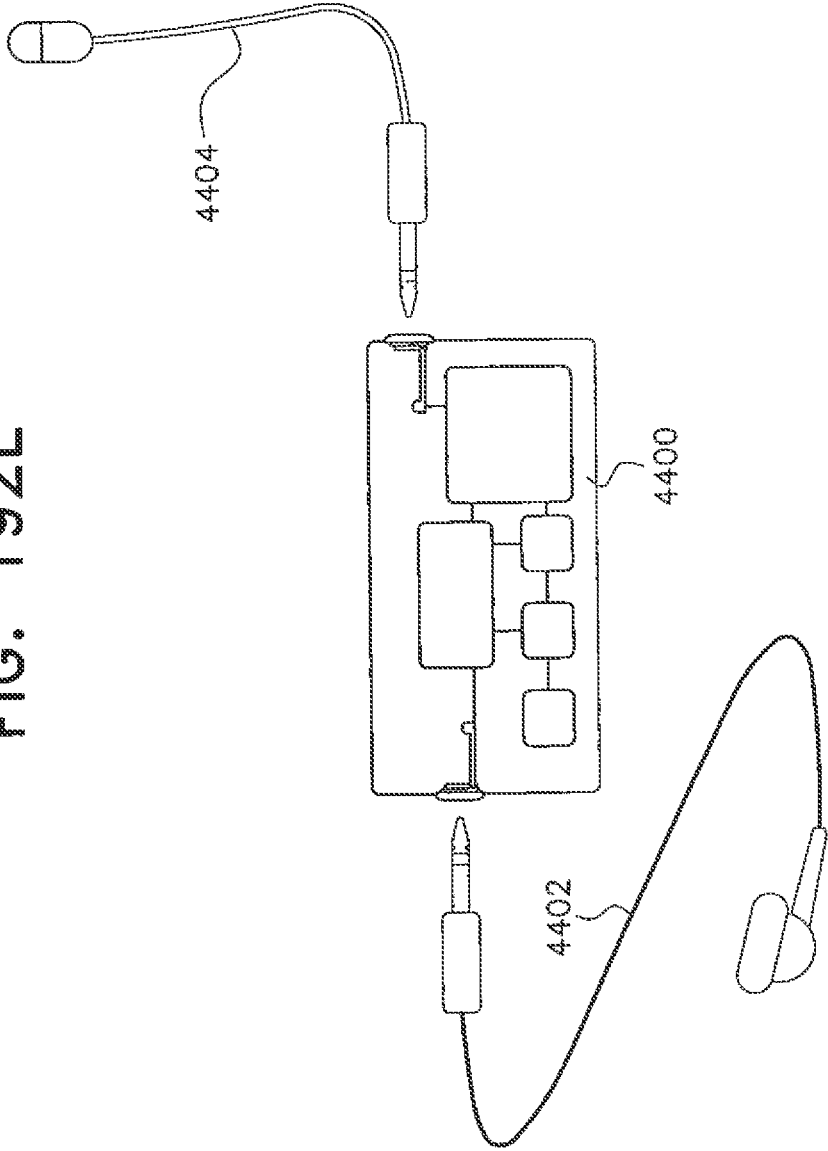

FIG. 192M

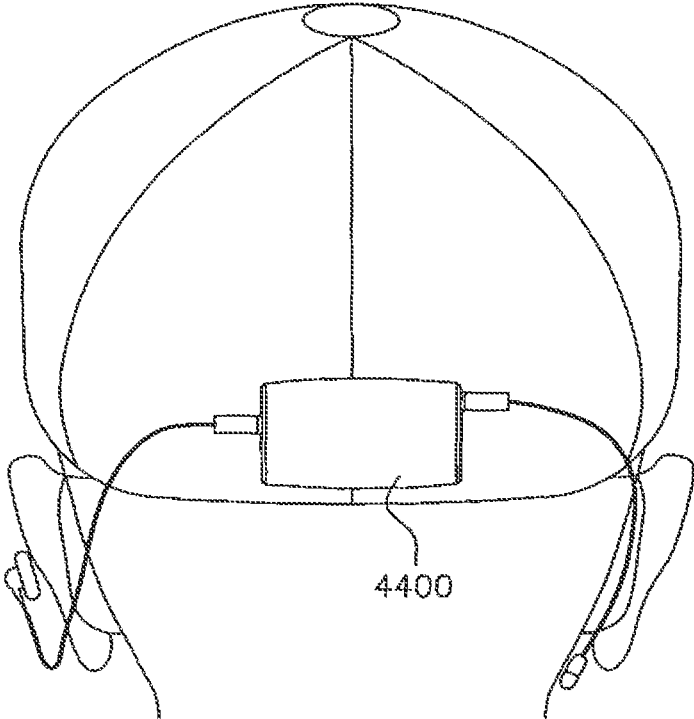

FIG. 192N

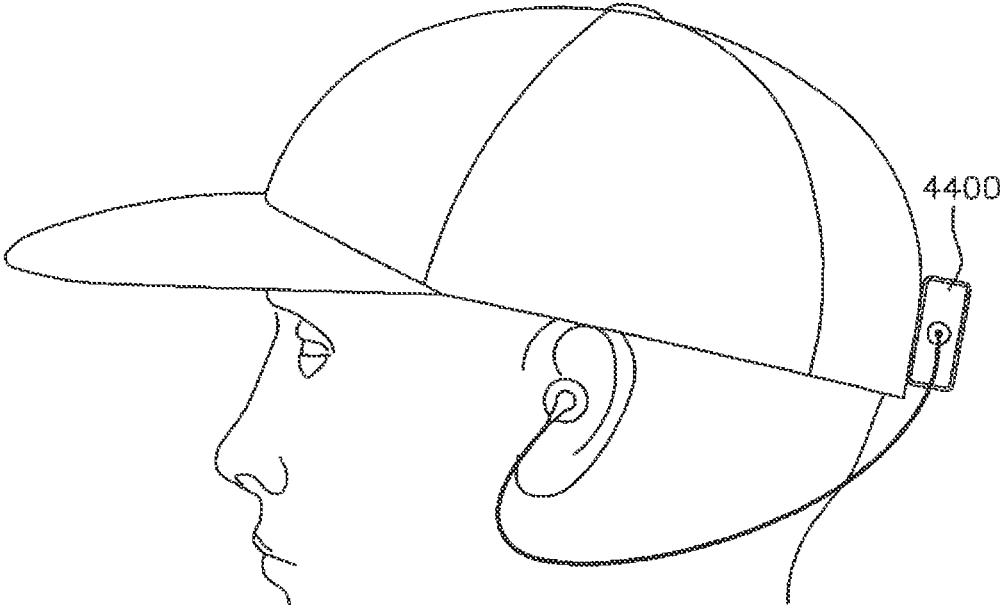

FIG. 193

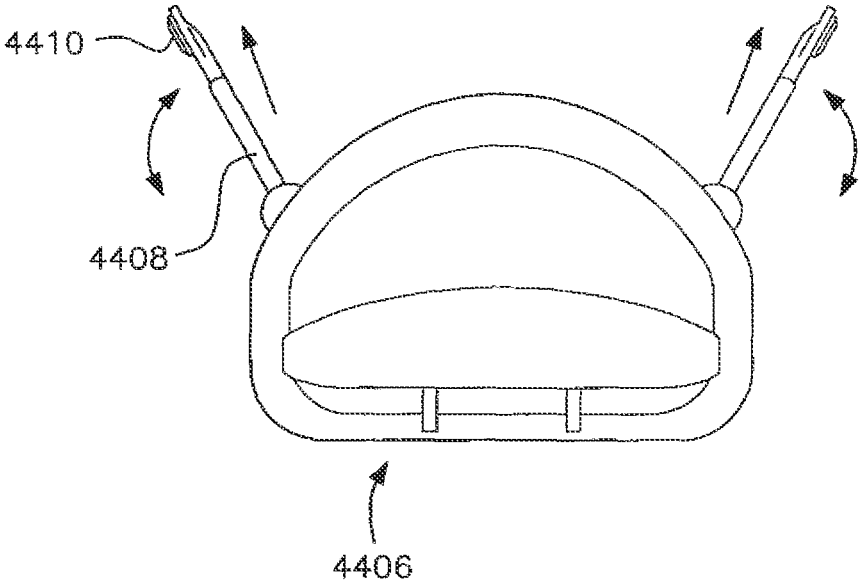

FIG. 194A

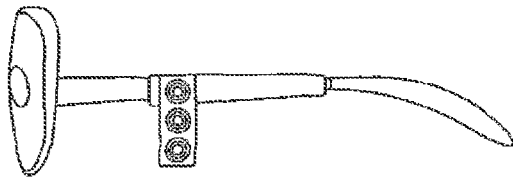

FIG. 194B

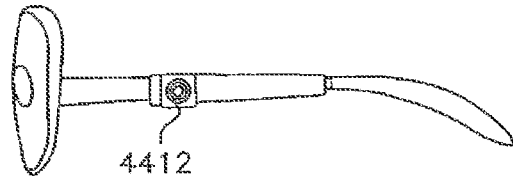

FIG. 194C

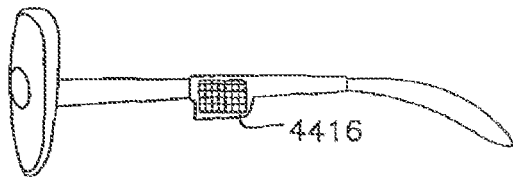

FIG. 194D

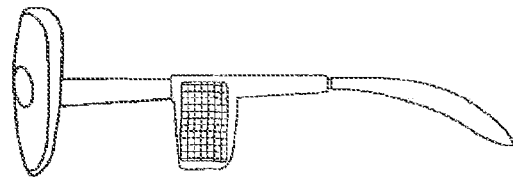

FIG. 194E

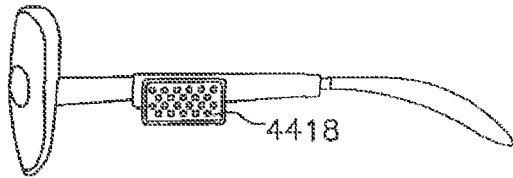

FIG. 194F

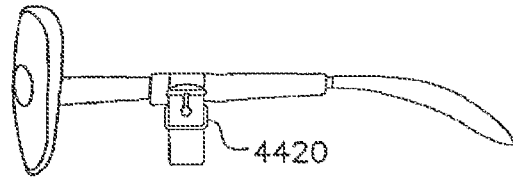

FIG. 194G

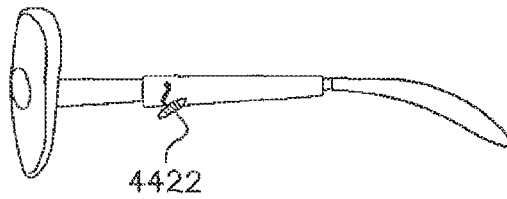

FIG. 195

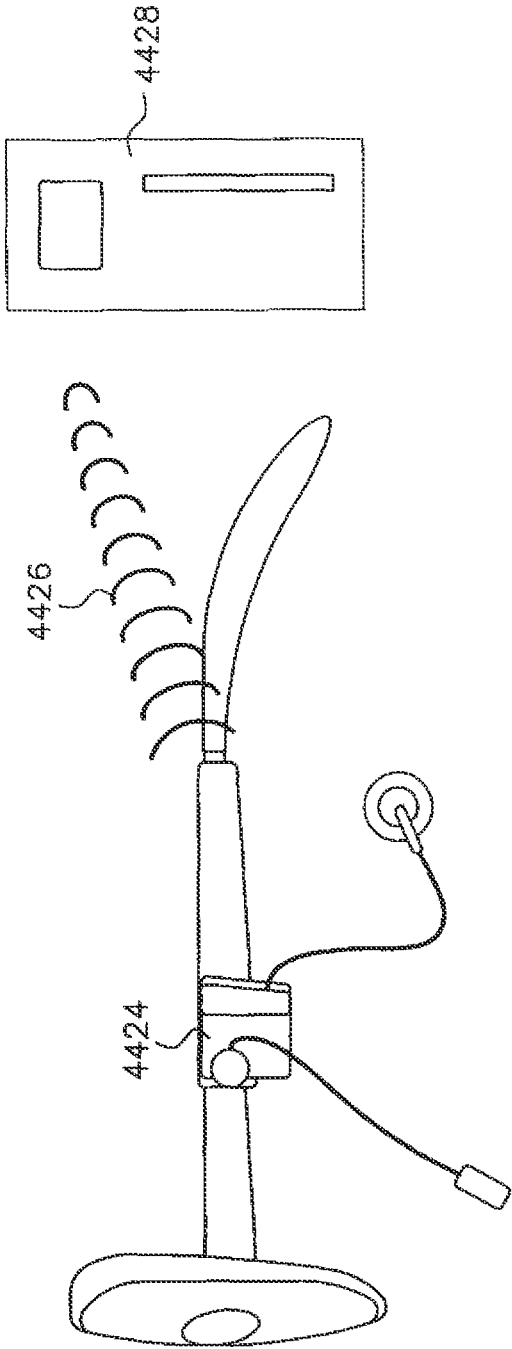

FIG. 196A

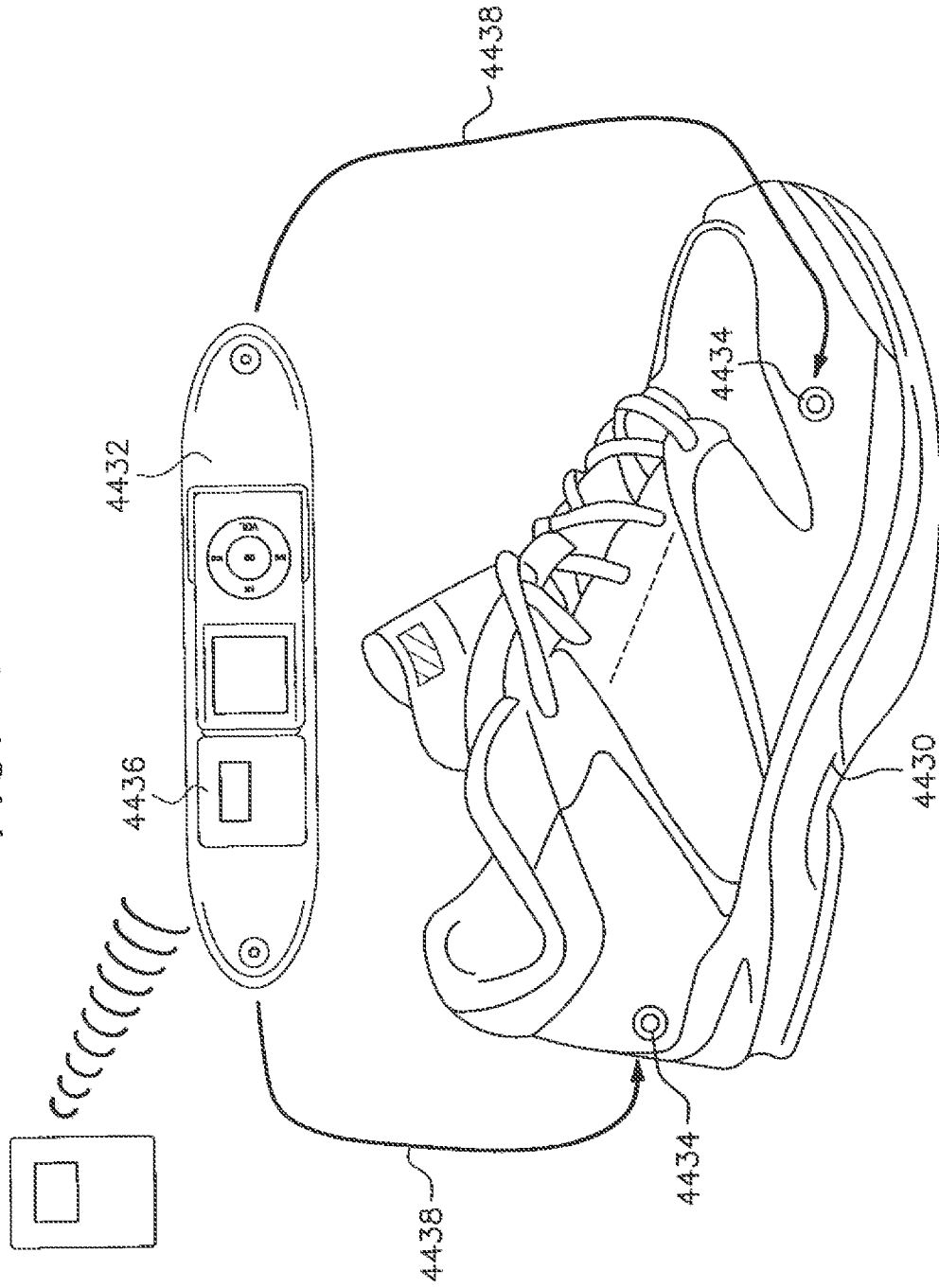

FIG. 196B

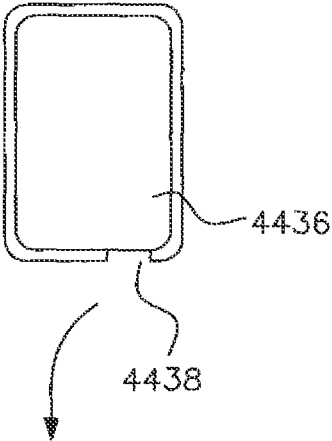

FIG. 196C

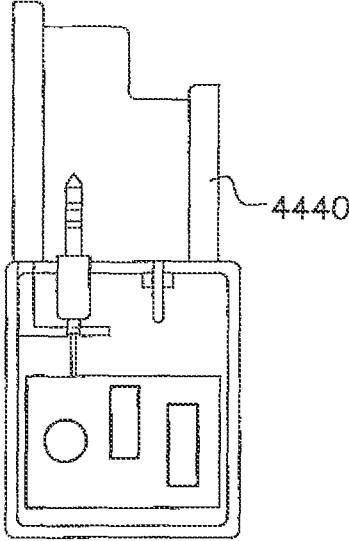
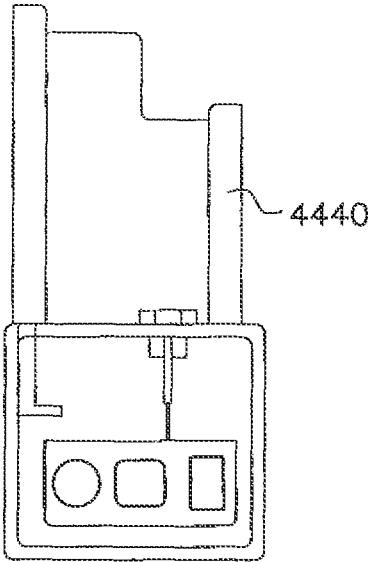
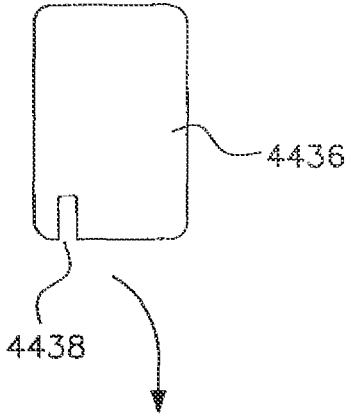

FIG. 196D

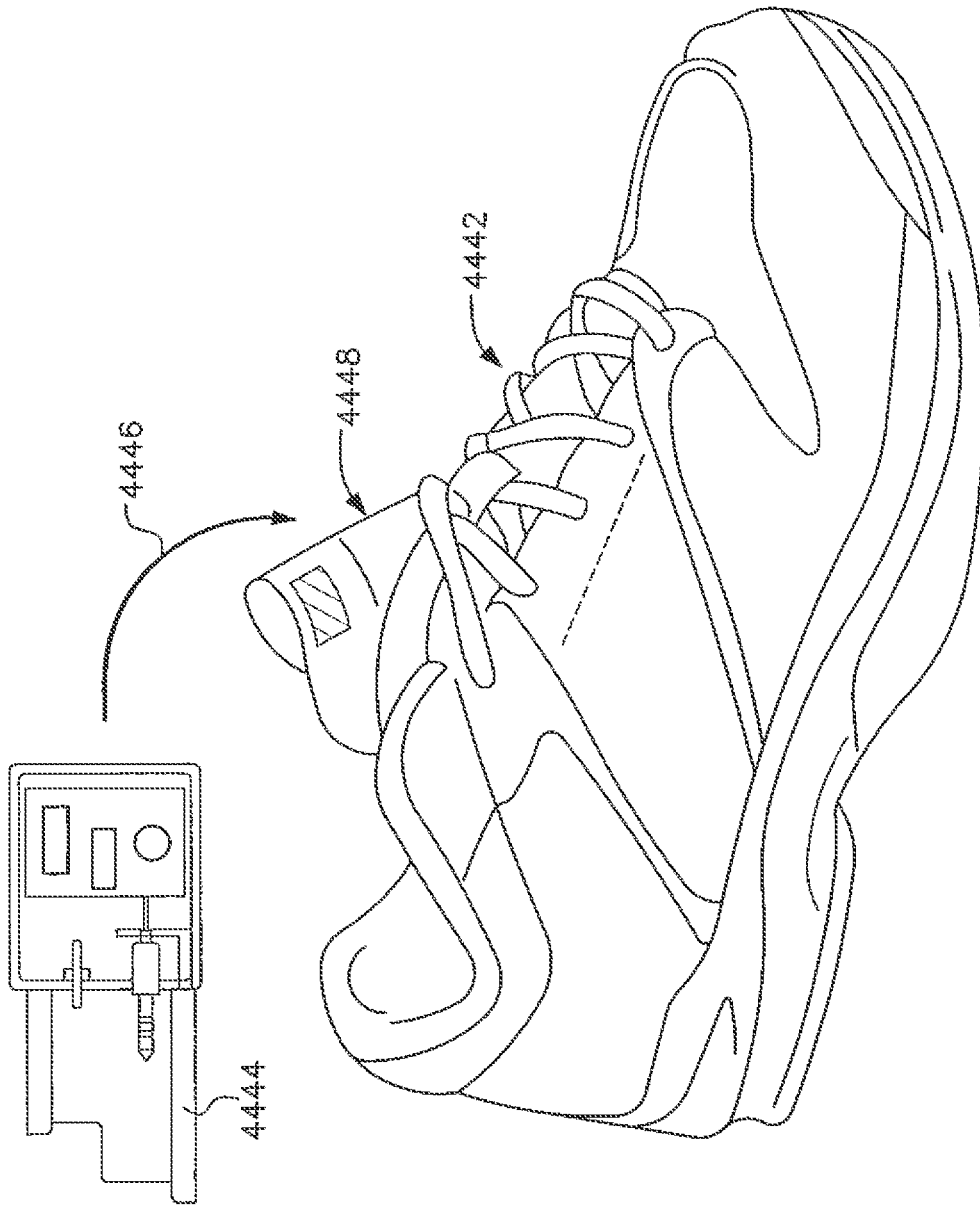

FIG. 196E

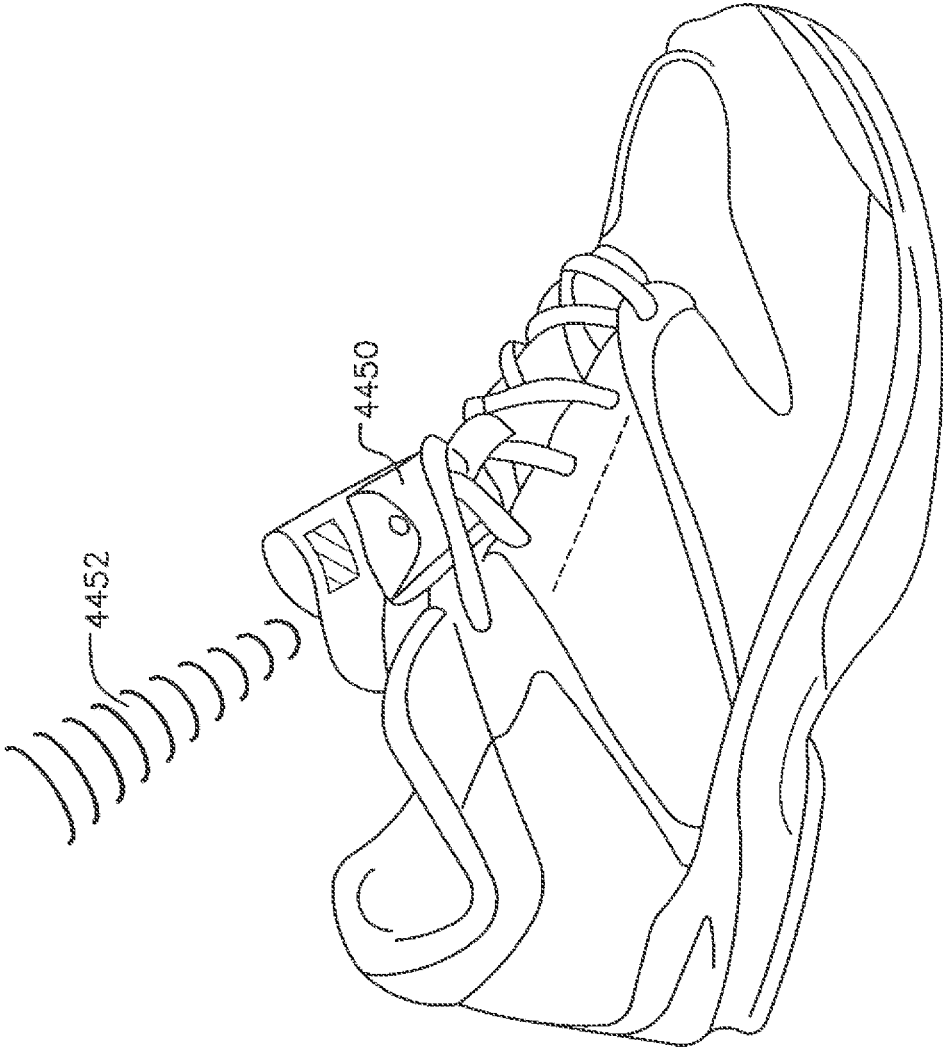

FIG. 197A

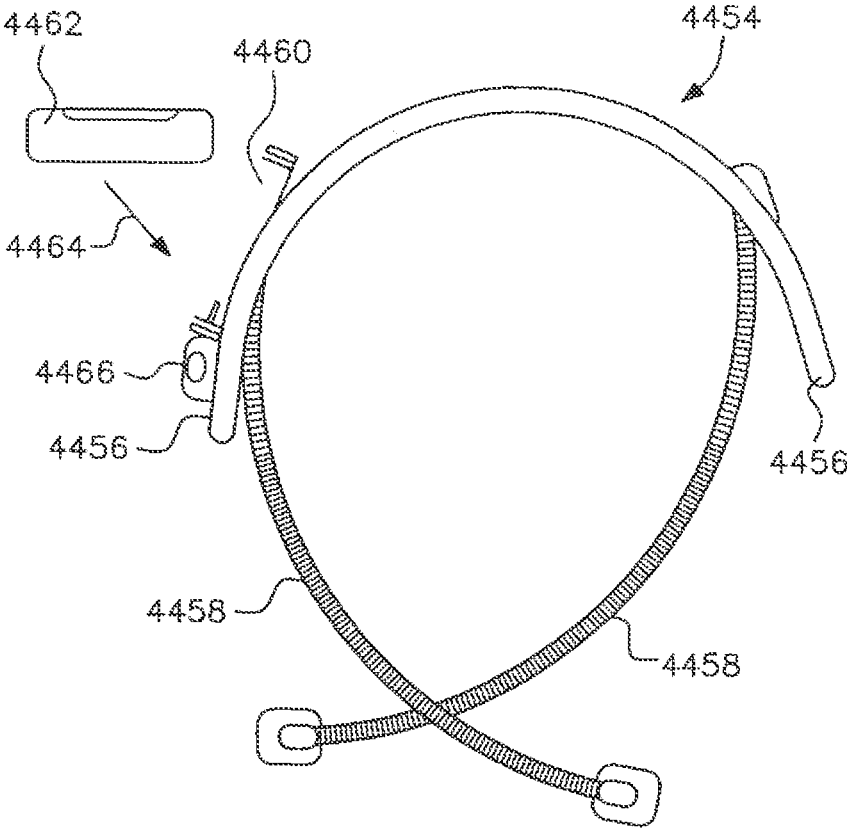

FIG. 197B

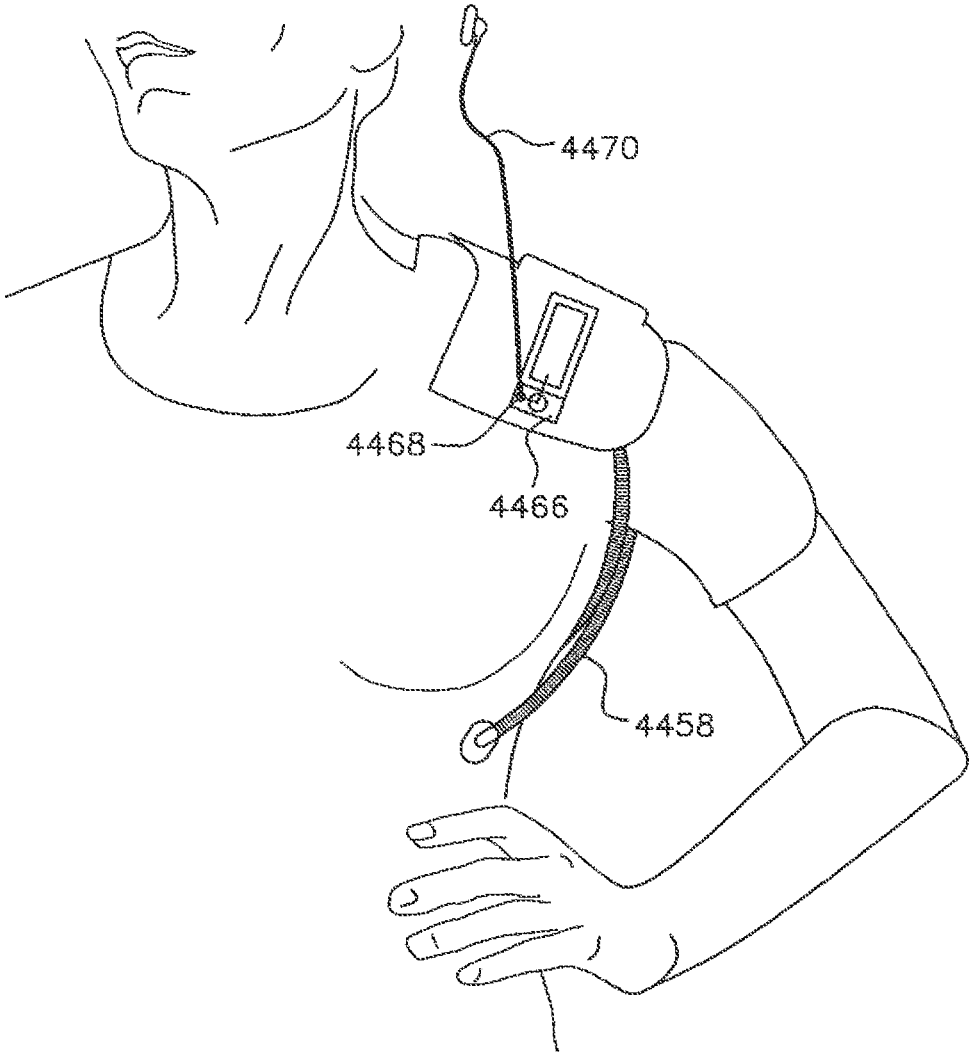

FIG. 197C

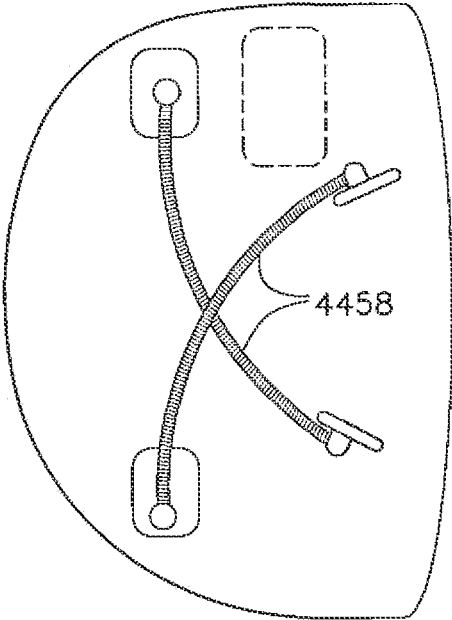

FIG. 197D

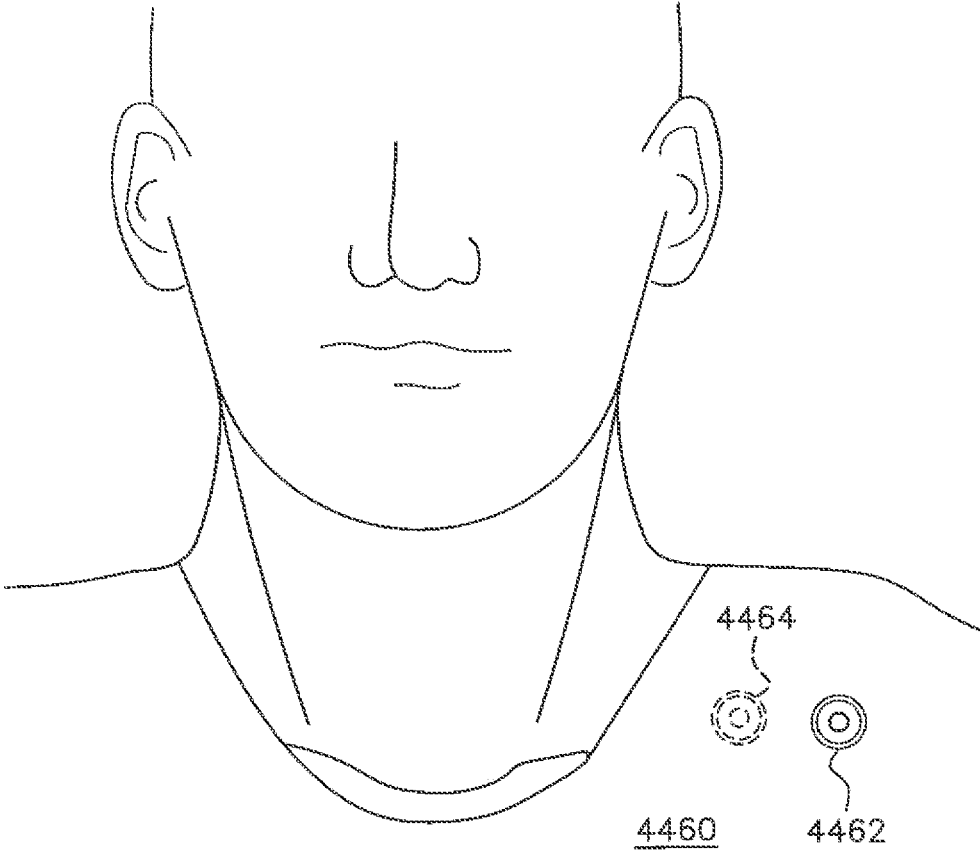

FIG. 197E

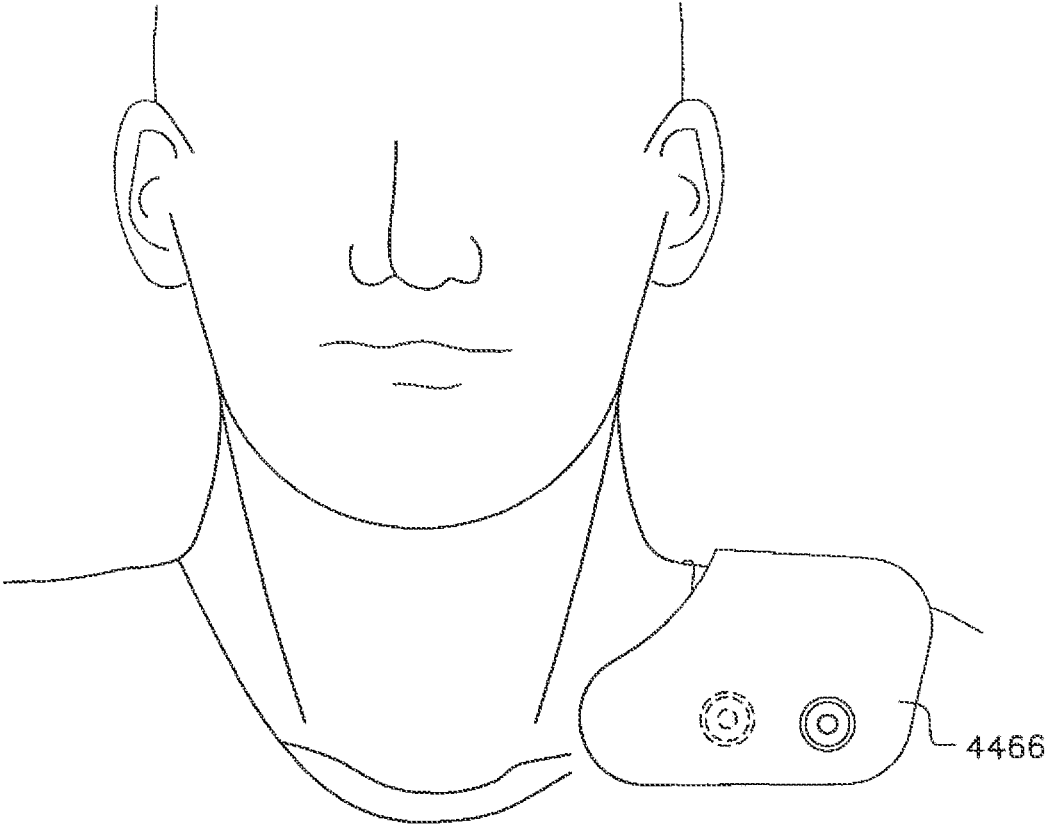

FIG. 197F

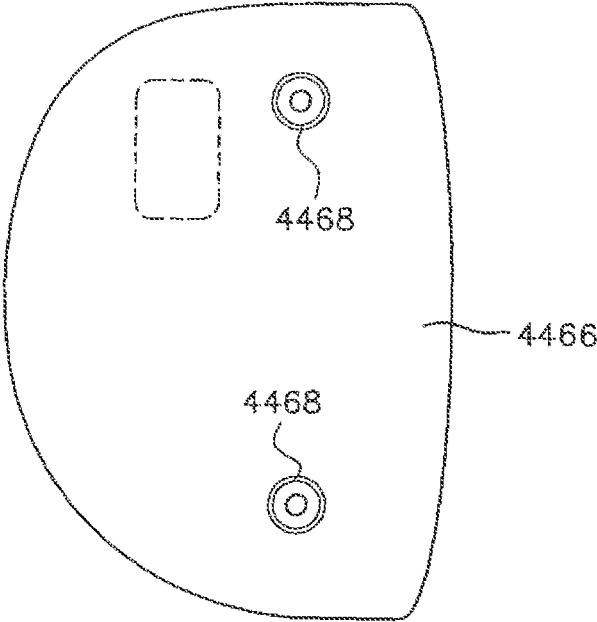

FIG. 197G

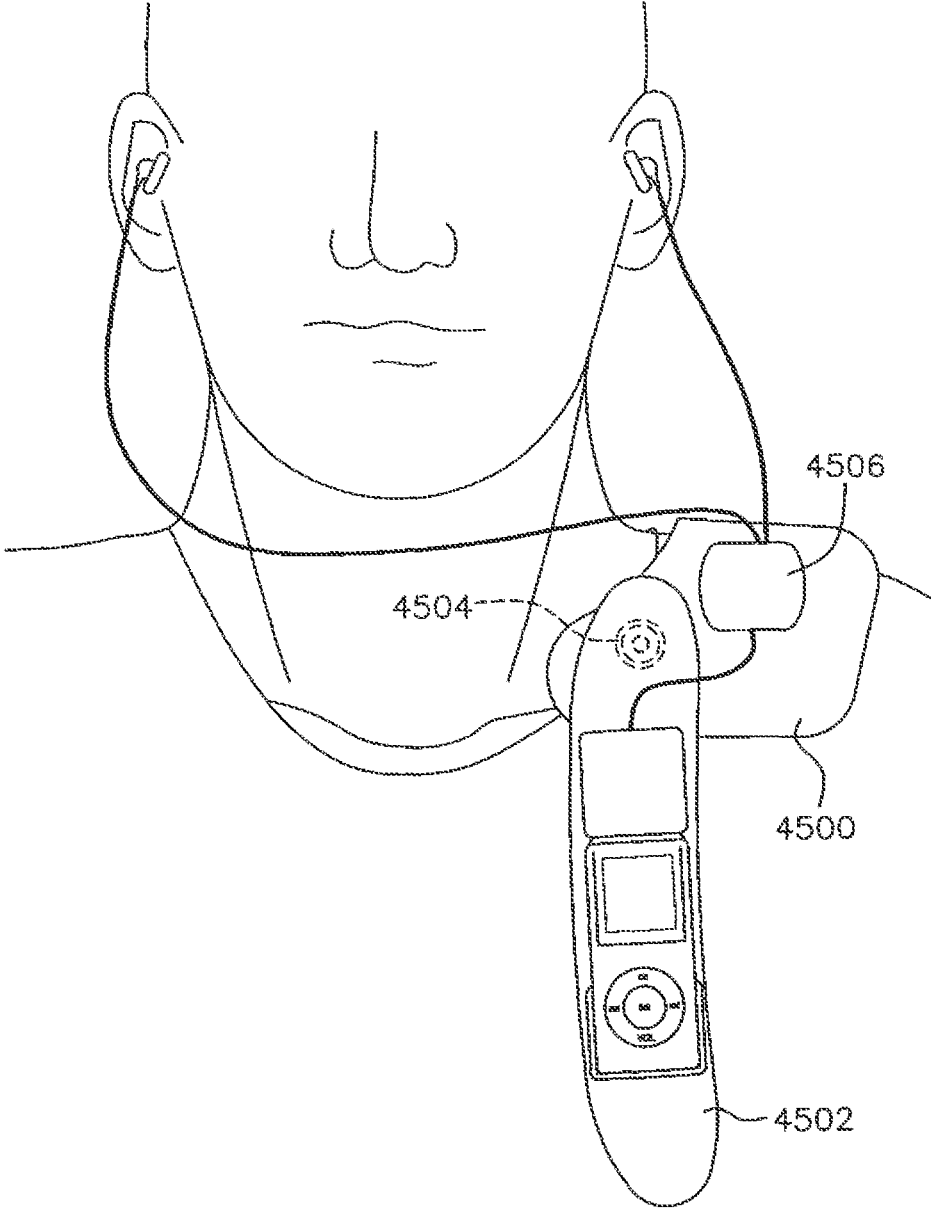

FIG. 197H

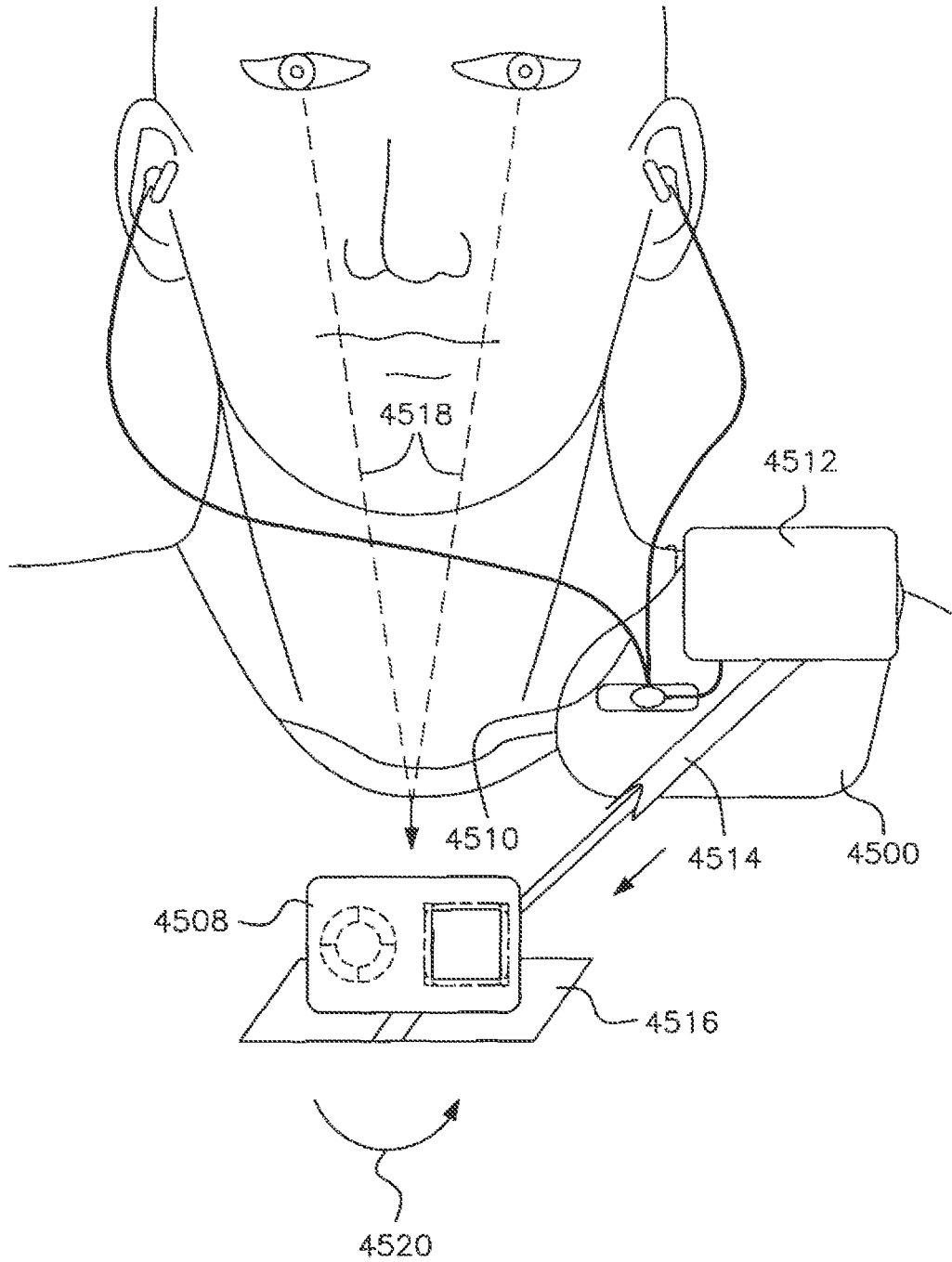

FIG. 197J

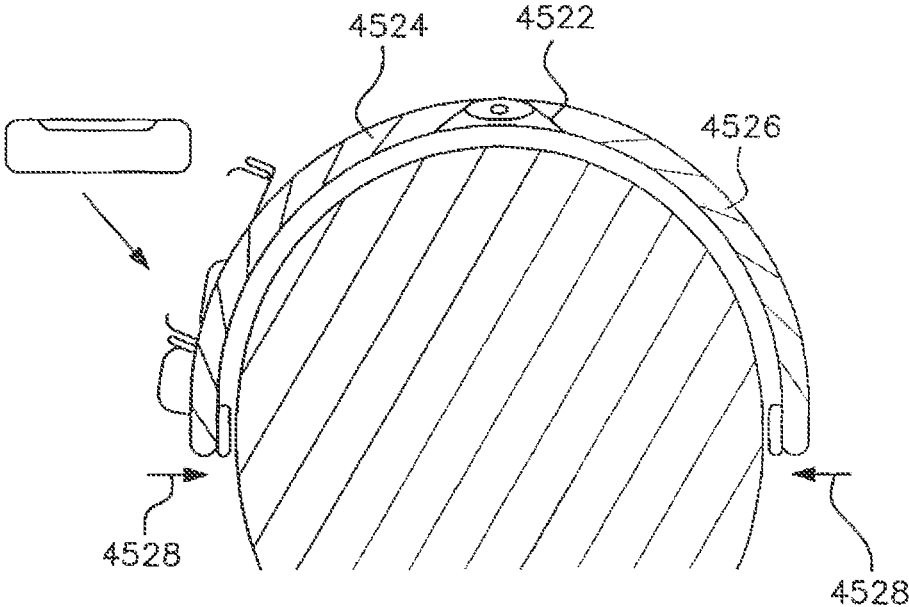

FIG. 197K

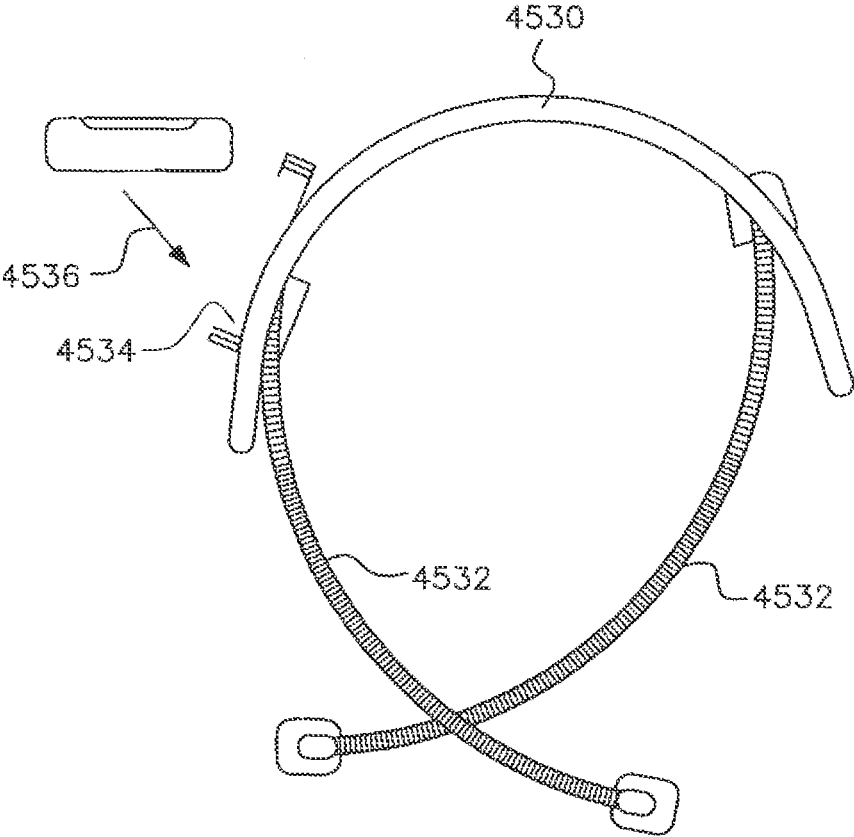

FIG. 197L

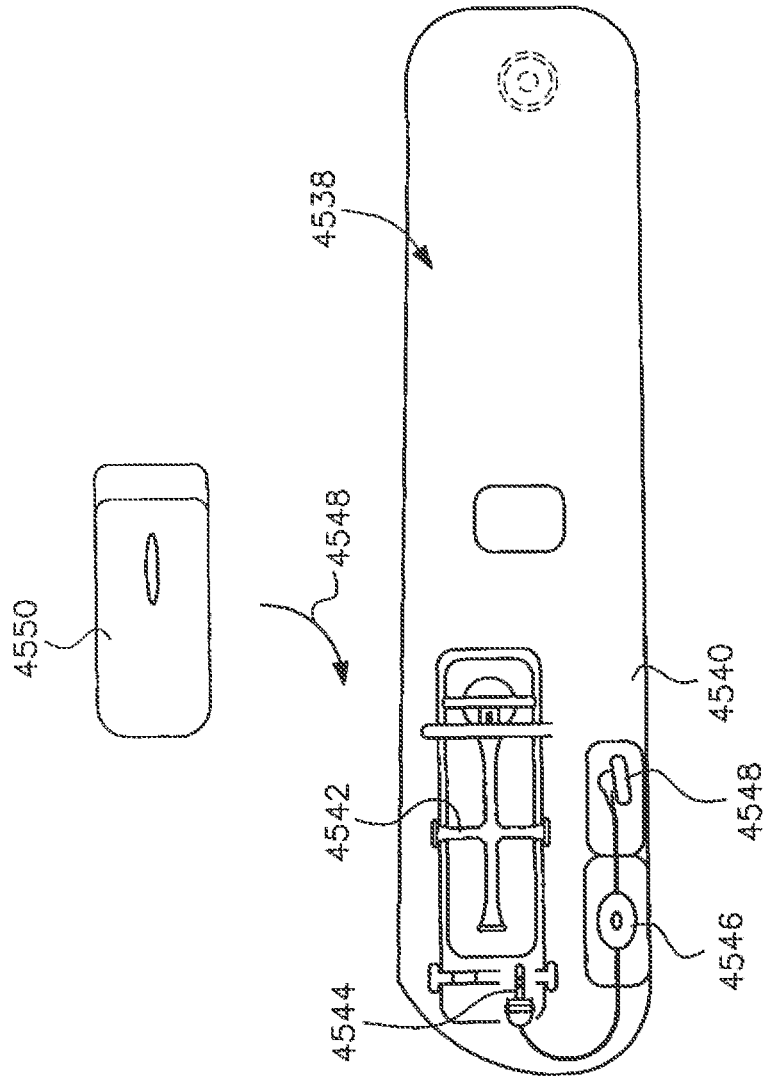

FIG. 197M-1

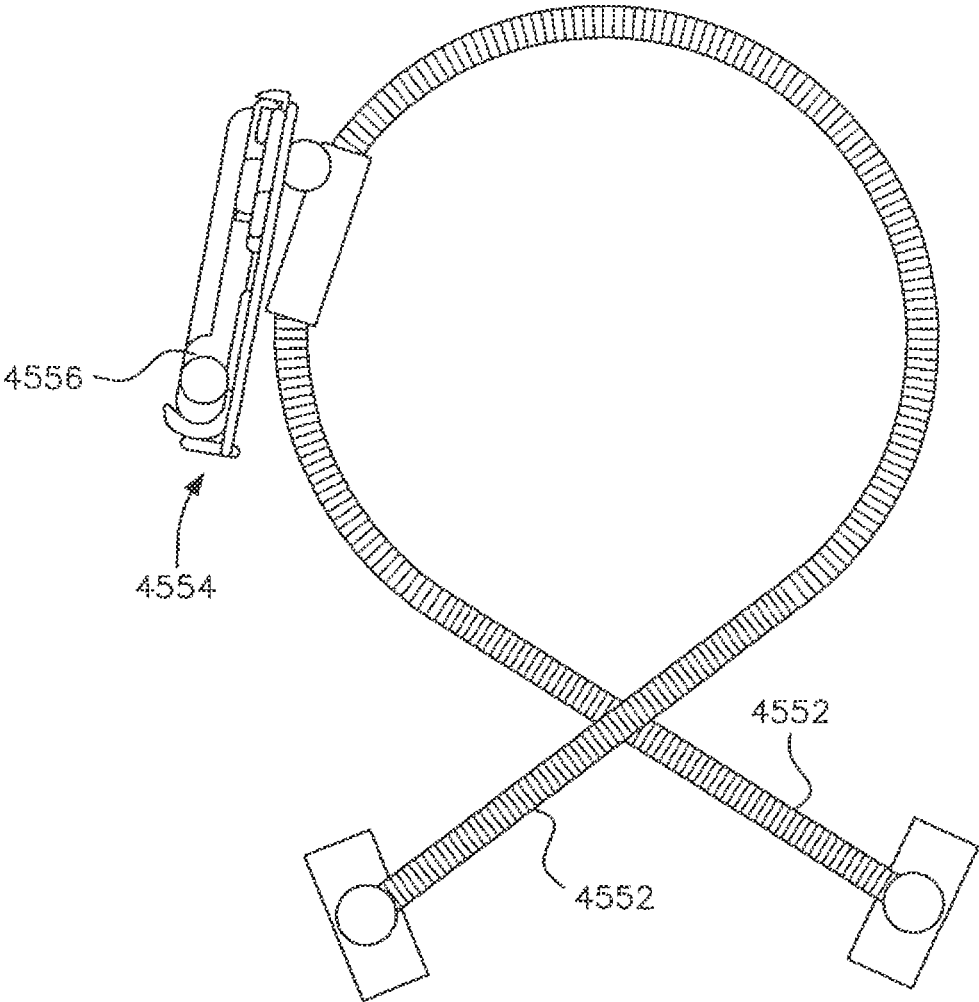

FIG. 197M-2

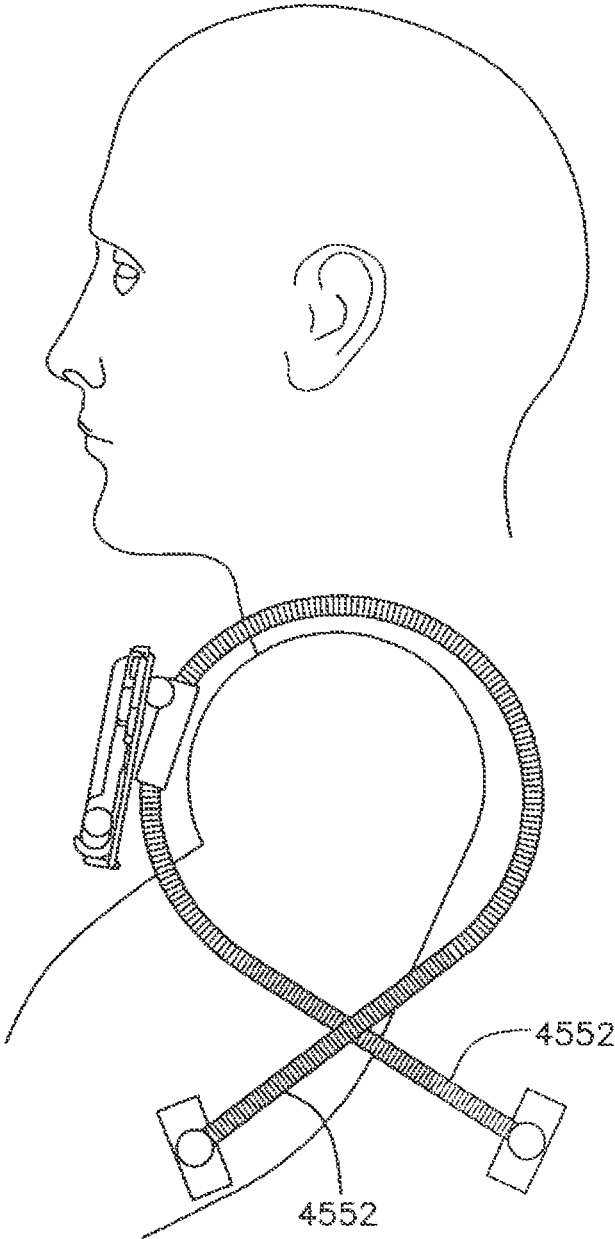

FIG. 197M-3

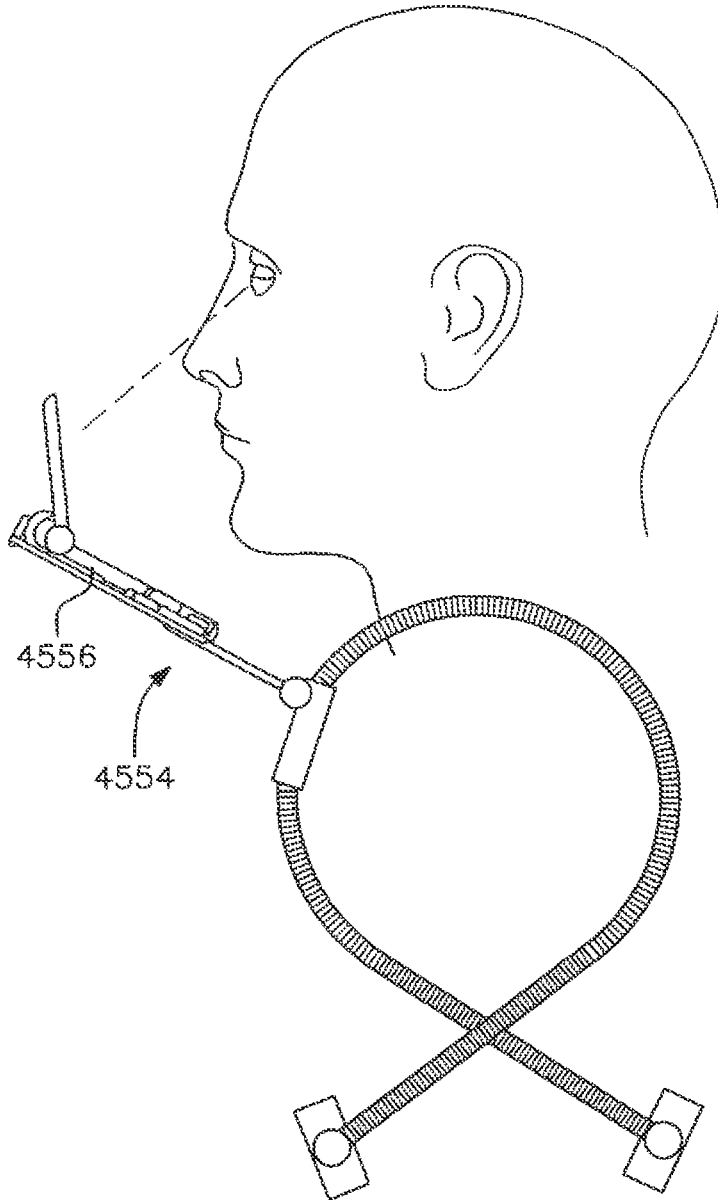

FIG. 197M-4

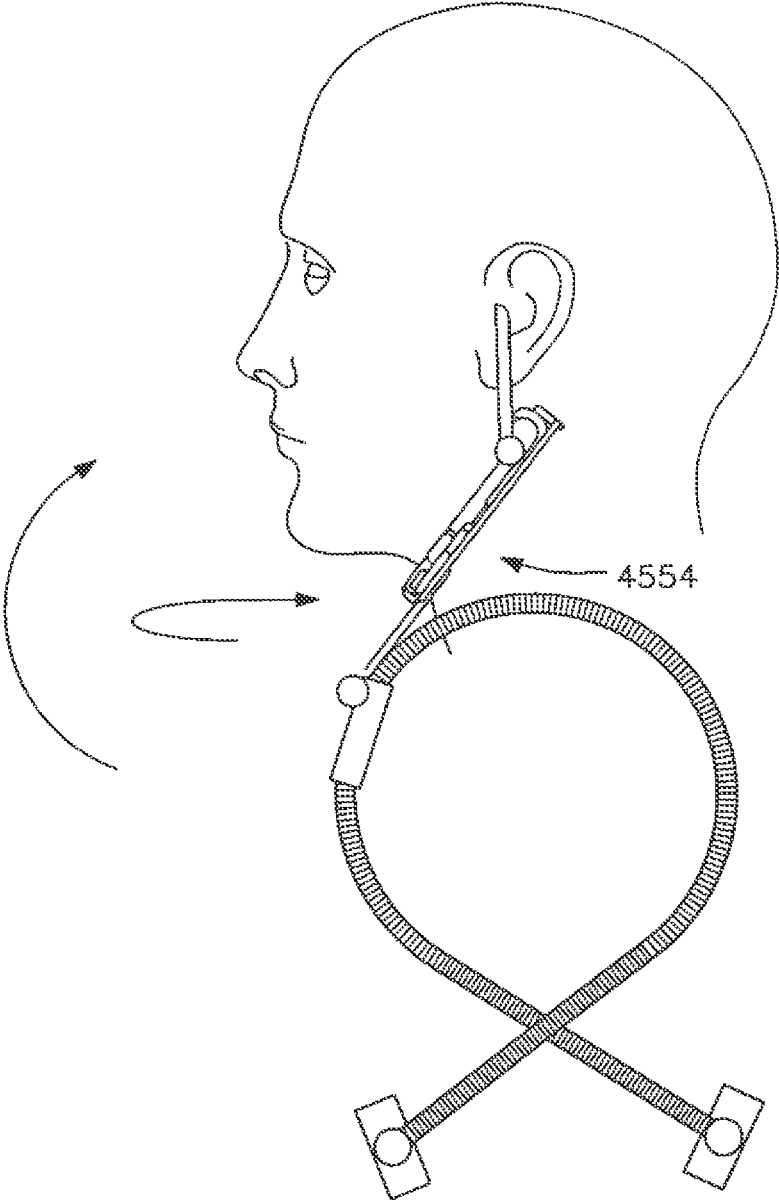

FIG. 197N-1

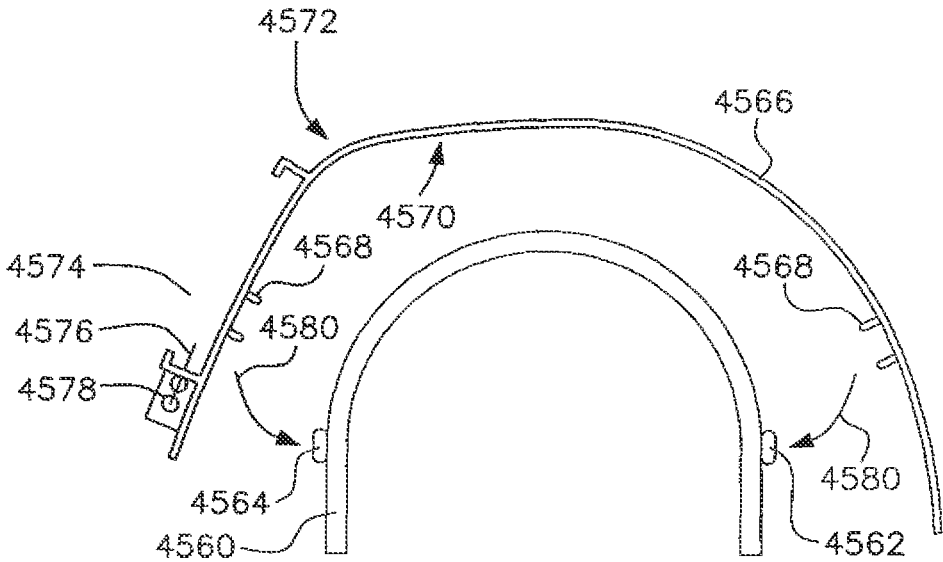

FIG. 197N-2

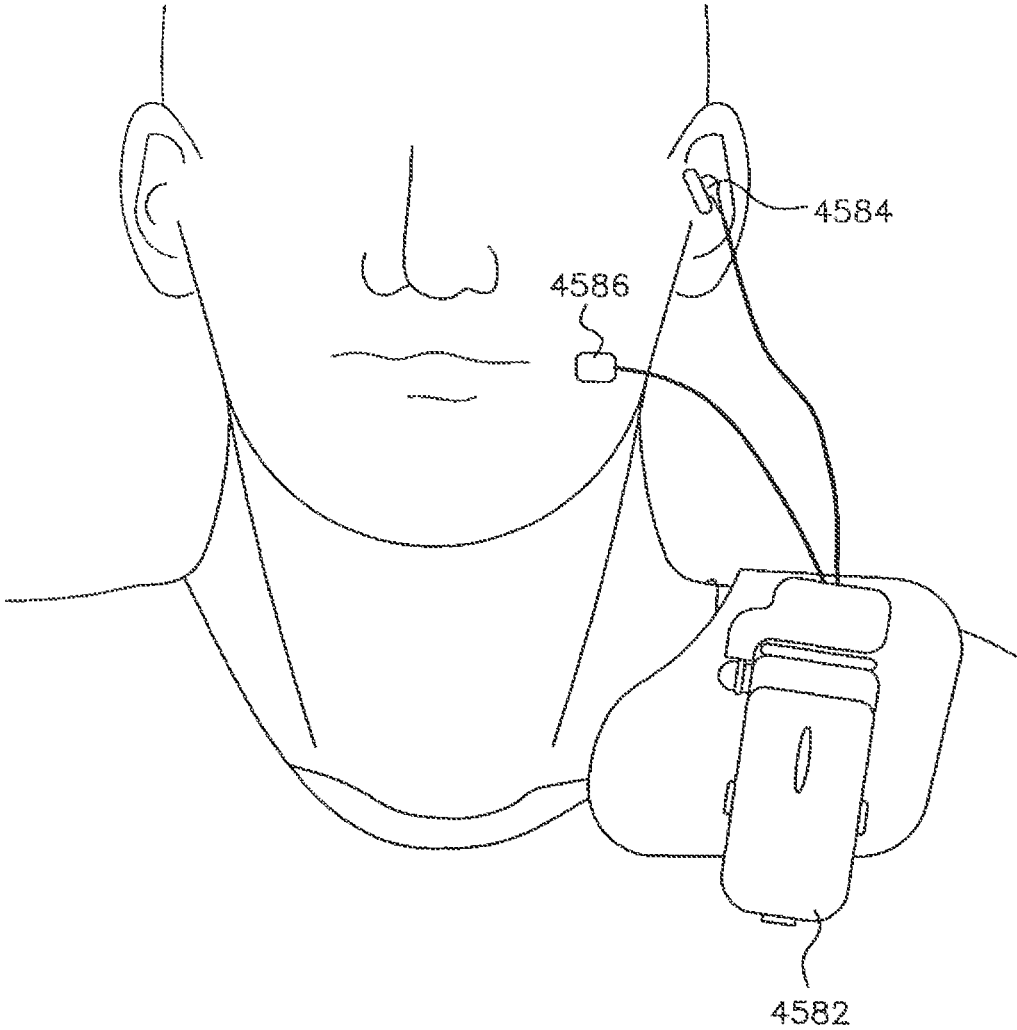

FIG. 197P

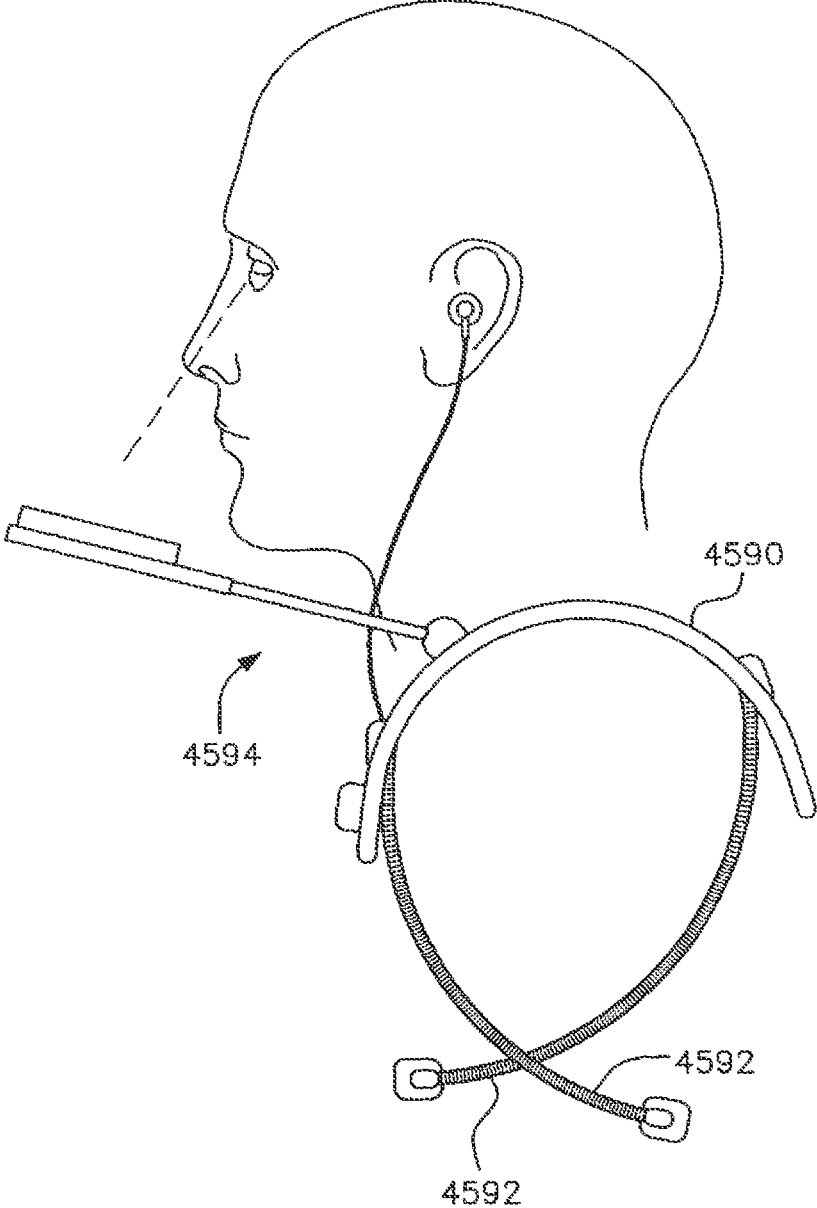

FIG. 197Q

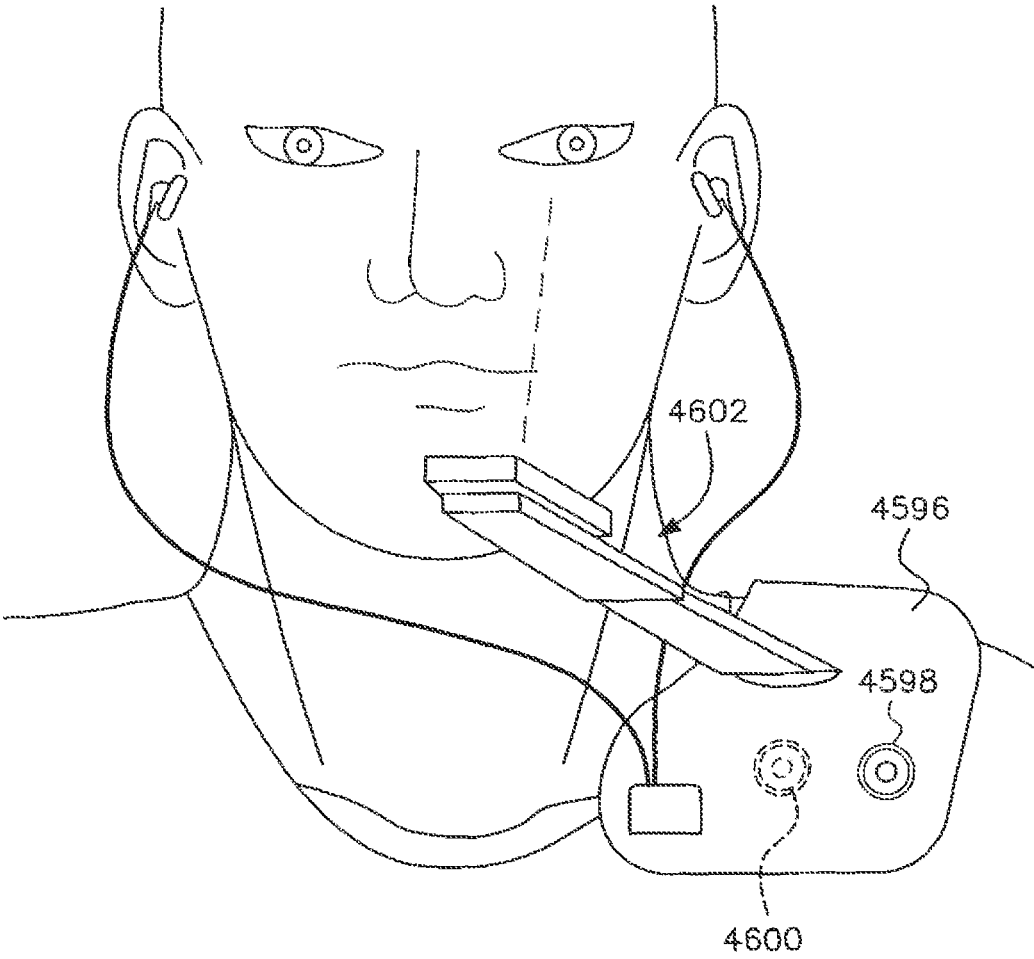

FIG. 197R

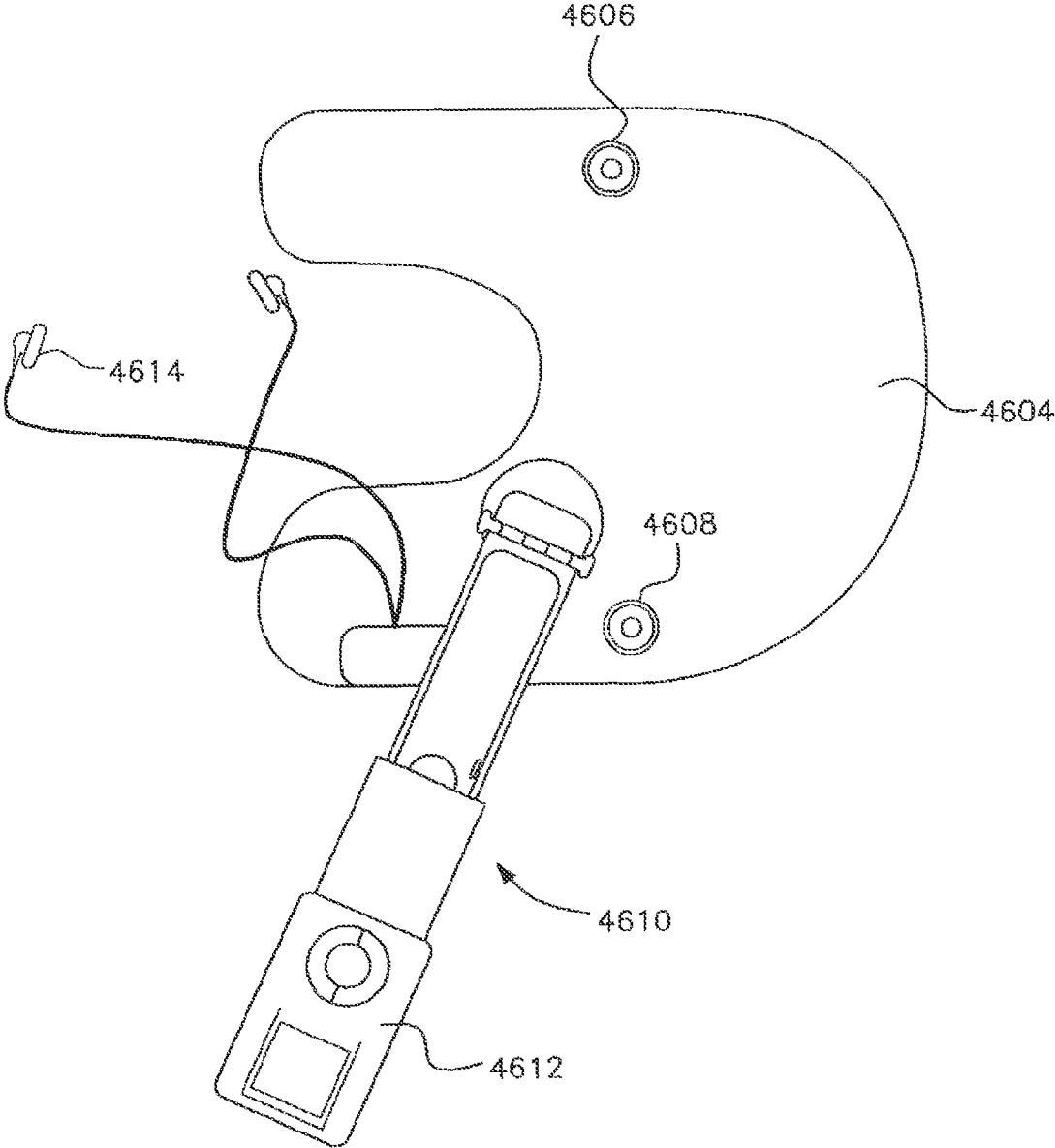

FIG. 198A

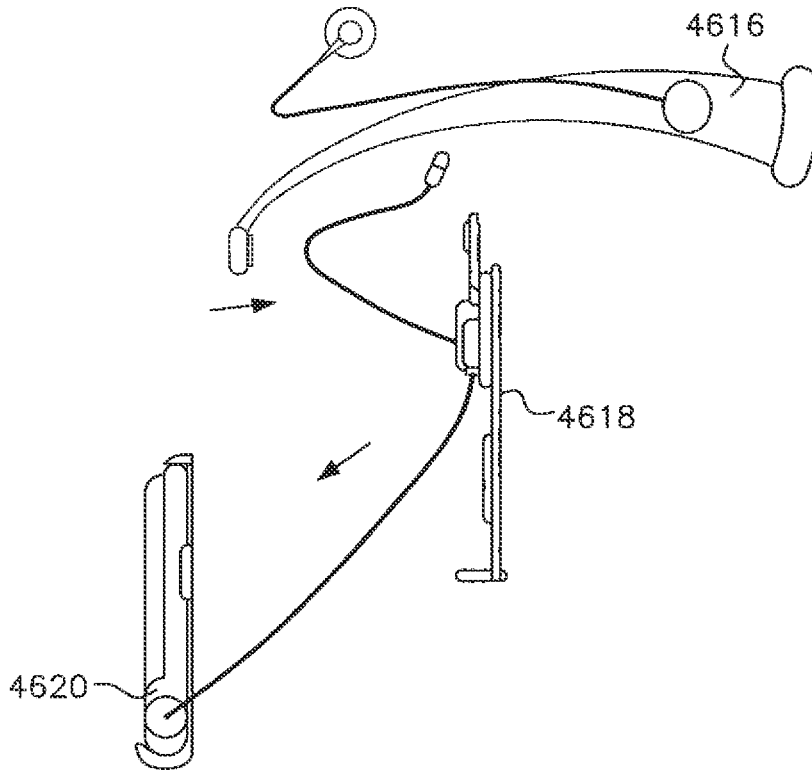

FIG. 198B

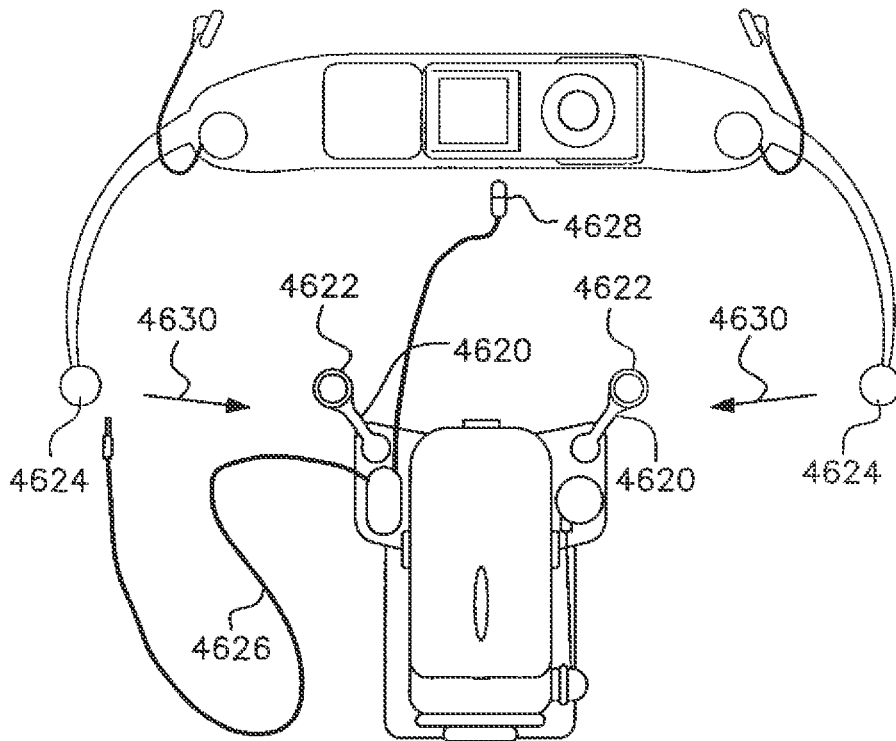

FIG. 199A

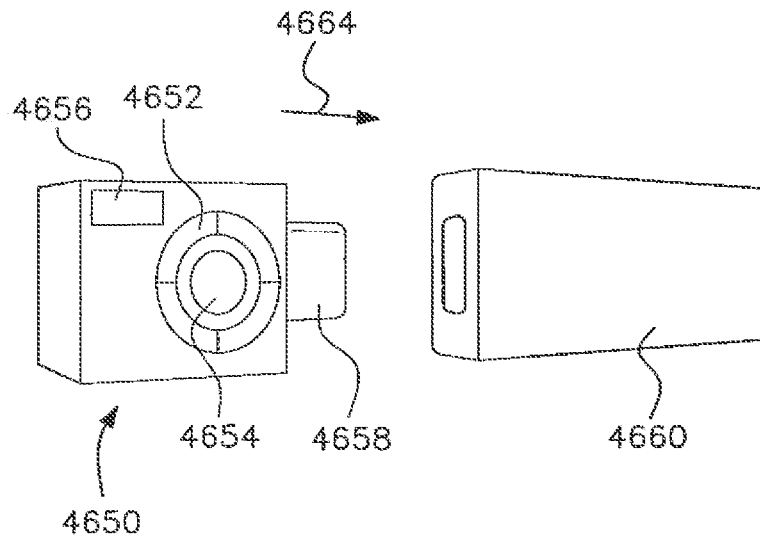

FIG. 199B

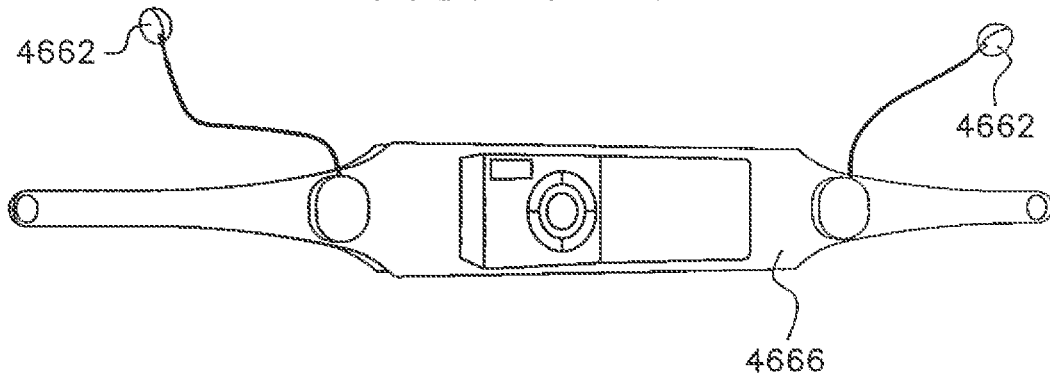

FIG. 200A

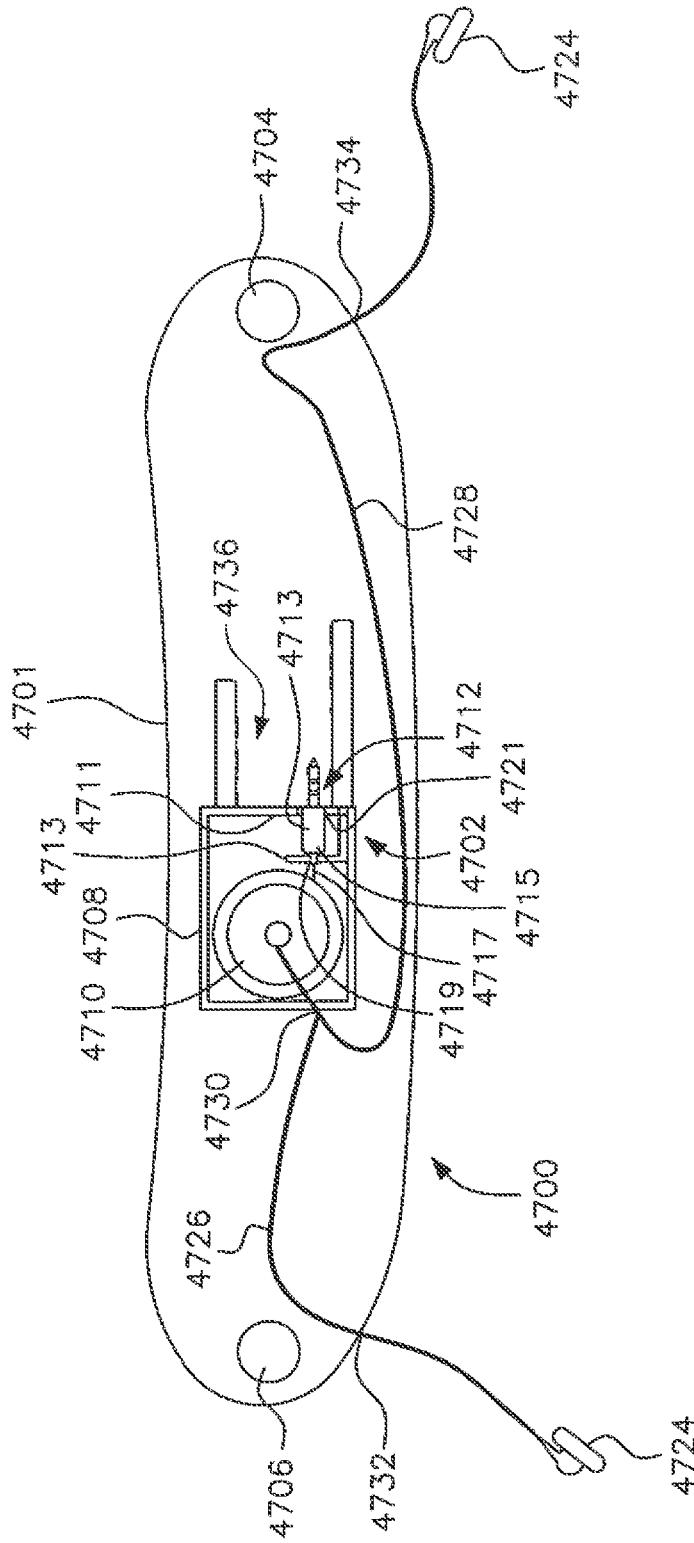

FIG. 200B

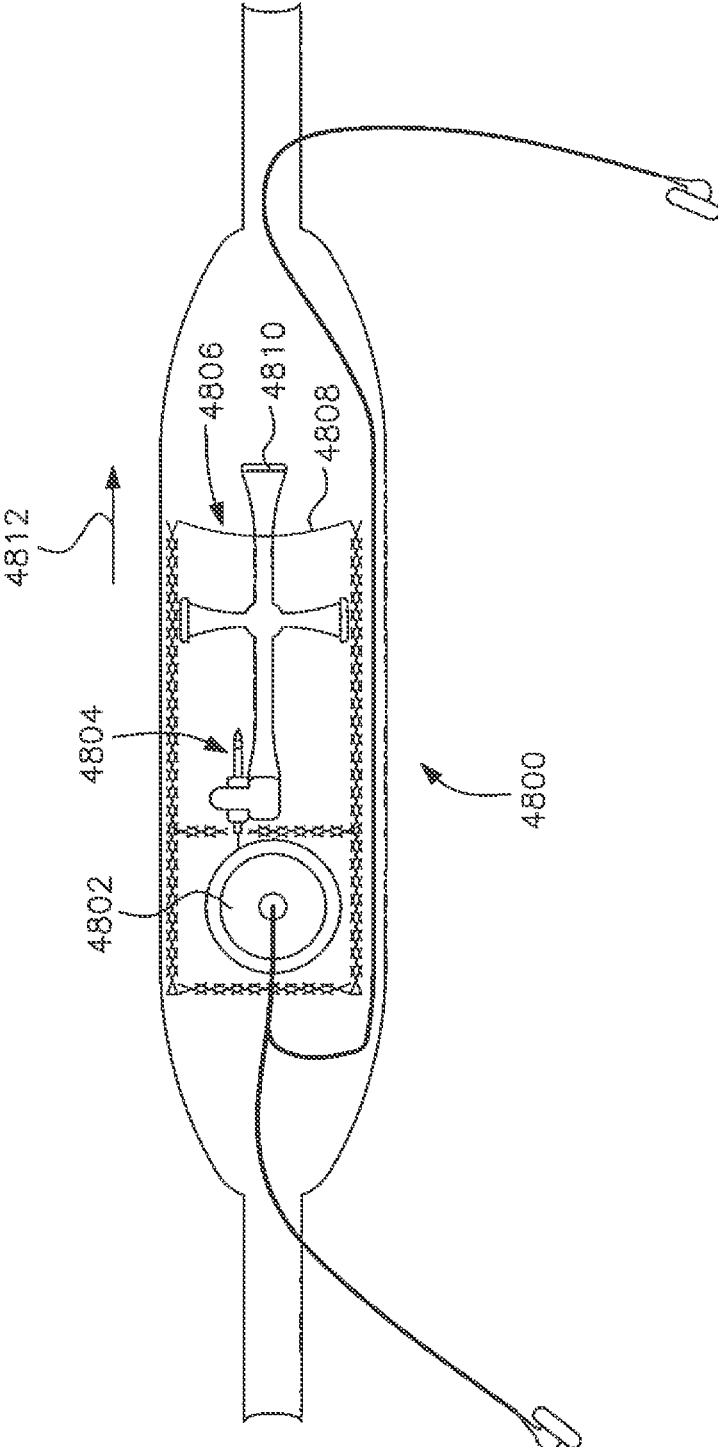
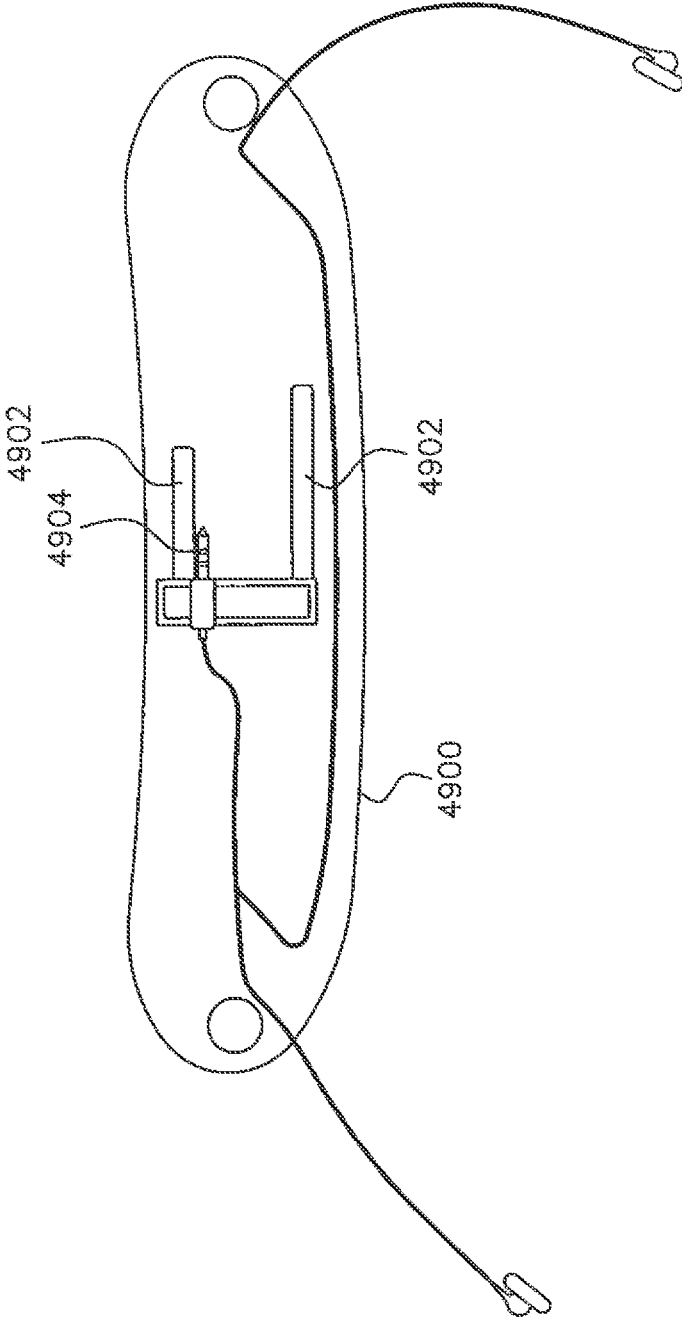

FIG. 200C



BIOLOGICALLY FIT WEARABLE ELECTRONICS APPARATUS

This application is a continuation of U.S. patent application Ser. No. 12/805,032 filed Jul. 8, 2010, which is a Divisional application of U.S. patent application Ser. No. 11/650,590 filed Jan. 8, 2007, now U.S. Pat. No. 7,810,750, which is a Continuation-in-Part application of U.S. patent application Ser. No. 11/637,952 filed Dec. 13, 2006, which is a non-provisional application of U.S. Patent Application Ser. No. 60/762,861 filed Jan. 30, 2006, U.S. Patent Application Ser. No. 60/756,549, filed Jan. 6, 2006, and U.S. Patent Application Ser. No. 60/749,579 filed Dec. 13, 2005, herein incorporated in their entirety by reference.

FIELD OF THE INVENTION

The present invention relates to the field of biologically fit wearable electronics.

BACKGROUND OF THE INVENTION

In recent years, the use of cellular phones, music players, video players, video games, computers, and a variety of hand-held electronic products has greatly increased. Because they are handheld, some of those electronic devices as computers are often carried by the user in a separate case. There have been attempts to create wearable electronics such as music players integrated into the frames of eyewear, eyewear radio devices as well as wearable computers. However, due to a disconnection between electronic products and the biological aspects of the human body, prior art devices have failed to provide a useful wearable electronic apparatus that adequately interact with the human body and which fit anatomically and physiologically with the body while allowing full interaction of senses including vision.

Accordingly, it would be desirable to provide electronic devices and electronic functions which are hands-free and can be worn on the surface of the body in a biologically fit manner. The present invention provides a convergence between electronic products and the biological and anatomical aspects of the human body and biomechanics of the body while providing a series of hands-free and interchangeable wearable electronic apparatus that can interact with human senses and physiology of the body in a practical manner.

Housing electronics and/or power source in the frames of eyeglasses, as provided by prior art devices, creates bulky, heavy, cumbersome, and uncomfortable gear, which consistently places a heavy weight against the users' ears which can generate discomfort. Moreover, such heavy and awkward eyeglasses are cosmetically undesirable with buttons, ear buds, and other unattractive parts being visible at all times, taking away the elegance that can be the key feature of eyeglasses frames, and making them unsuited for use on a daily basis including at work, at school, or attending formal events.

A further problem for the prior art devices is that they rely on wires passing through the hinges at the front portion of the temples. This makes the manufacturing process difficult and more expensive. In addition, because the wires running through the hinges are repeatedly folded and unfolded with the temples of the glasses, the wires have a tendency to become damaged, substantially reducing the useful lifespan of the products.

The large size and heavy weight of eyeglass frames housing electronics can prevent a comfortable fit and use. U.S. Published Patent Application Nos. 20040059212 and

20040242976 describe eyeglasses to measure biological parameters wirelessly. However, because the electronics and wireless transmitter are housed in the eyeglass frames, the frames are heavy and can cause discomfort over time.

Bulky, prior art eyeglass frames or head mounted gear that house electronics and/or power sources and/or and unsightly ear buds in a non-removable fashion require the user to wear the device at all times, even when the electronic functionality of the device is not being used.

The prior art also discloses "wearable" computers. Typically, however, these devices are complicated and not practical to use. Moreover, because they are not adapted to fit well onto a human body, their weight is not well distributed, and will normally cause discomfort to the wearer, discouraging long term use of the devices.

Wearable articles of clothing (including hats) with permanent electronics embedded on them are financially unattractive, because discarding the wearable article would also require throwing away the embedded electronics device. Similarly, a desire to replace or upgrade the electronics device requires disposal of the wearable article.

Many people use different types of portable electronic devices, such as cell phones, MP3 players, PDAs, etc. Another deficiency of the prior art is a failure to disclose eyeglasses, eyeglass accessories, or wearable articles in which the user has the option to choose from a plurality of electronic functionalities using the same eyeglasses frame, eyeglass accessories, or wearable article. The prior art also failed to disclose eyeglasses and eyeglass accessories in which the user has the option to choose from electronic devices already in possession by the user. With the present invention if the user already has several hand held devices, such as a cell phone, a music player, a GPS device, and a PDA, the user can turn all of those devices into hand free devices and wearable on the body, without the need for the user to buy a new electronic device to be worn on the body.

Another problem with electronic devices such as computers, DVD players, cellular telephones, digital music players, and electronic organizers, is that in order to be operated they require the user to hold the device or place the device on an object (such as a piece of furniture or the floor) for support. It would be very useful to have an electronic device which does not require being held or placed on an object for support.

In addition, "hand-held" devices require that they be held. While some cellular phones and digital music/video players have accessories that permit the user to use the device without having to hold it, using such apparatus and accessories is cumbersome, and it is necessary to carry and store the accessories until they are actually used. Furthermore, it is easy to forget to bring the accessory, such as the ear bud or a strap to secure a digital player to the body, when needed.

Furthermore, electronic eyeglasses and electronic eyeglass accessories of the prior art, by not having a structure designed for interchangeability, require the user to buy and carry many devices for achieving different functions. This requires the user to have one electronic eyeglass accessory for a radio, another electronic eyeglass accessory for a music player, and a further one for a cellular phone. This increases cost for the user which has to buy several electronic eyewear accessories and the inconvenience of having to carry several electronic eyewear accessories. This also increases cost for the manufacturer which now has to make different devices losing economies of scale, difficulties with keeping inventory of different models, and has problems with shelf space by having to display different models. It would be desirable, as provided by this invention, to have an electronic eyewear

accessory which is low cost and that universally can accept any electronic device, therefore allowing the user to only carry one electronic eyewear accessory.

Moreover, hand-held devices are easily lost or misplaced, and unattended hand-held devices can be easily stolen. It is common for people to forget their hand-held devices in restaurants, airplanes, taxi cabs, etc. It would be very useful to have a non-hand held and hands-free device that can be worn in a comfortable, non-obtrusive, and biologically-fit manner without requiring the user to carry extra devices or accessories in addition to the equipment already being worn on the body.

The Problem of Pain and Discomfort

The human body has a limited ability to support weight before pain is elicited. Furthermore, each part of the human body, such as the neck, shoulder and ear has different thresholds for activation of pain fibers. If the weight pattern is not biologically fit, the stimulus of the device on the skin will become annoying, and pain receptor endings within the skin will be stimulated. By adequately spreading the weight of the electronic wearable article resting on the body only pressure receptors of the peripheral nerves are activated, and not the painful "nociceptors" (described further below). By providing a wearable electronic device with a biologically fit weight distribution pattern, the pain and discomfort associated with the weight of the device is not elicited.

There are basically three sensory responses from contacts with the human skin: (1) mechanical sensations, (2) thermal sensations, and (3) nociceptive or pain sensations. Nerve fibers course into the skin through the dermis, and many of them end at the dermal-epidermal border where many of the sensory receptor structures are located. The largest class of receptors consists of the ones with no specialized structure at all, which are the free nerve endings for pain, whereas encapsulated nerve endings are usually associated with light touch and pressure sensations.

Axons of peripheral nerves are divided up, according to their conduction velocity, into A, B and C fibers. The A fibers are subdivided into A α , A β , A γ , and A δ classes, in descending order of conduction velocity. Ordinary sensory information such as touch information is conducted by A β fibers, and pain sensation is carried by A δ and C fibers. For any wearable electronic article to be worn comfortably for long periods of time, the design and weight distribution as well as the weight pattern of the apparatus should not activate A δ and C fibers of the anatomic region supporting the electronic device.

The pain receptors and C fibers in the skin of the ear are activated at a much earlier stage than the pain receptors and C fibers of the nose. Therefore, to prevent activation of the user's pain receptors, a biologically fit weight pattern for eyeglasses distributes as much weight as possible onto the nose and as little as possible directly against the ear. Likewise, the C-fibers, pain receptors and pressure receptors in the neck are activated earlier than the C-fibers, pain receptors, and pressure receptors of the shoulder and chest. Therefore, to increase the time prior to activation of pain receptors, a biologically fit weight pattern, for a wearable computer for example, includes distributing the weight in the shoulder and chest area and avoiding the weight being supported solely or mainly by the neck. Other biologically fit embodiments that distribute the weight in the back and shoulder area will be shown in the accompanying drawings and description.

Good weight distribution, as taught by the present invention, needs to be coupled to a proper amount of weight, to avoid activating mechanically sensitive nociceptors, which

lead to discomfort and painful sensation. To prevent stimulation of pain, it is necessary that the weight of the apparatus applied to the anatomic area only activates pressure receptors but not C fibers and pain receptors. In the case of wearable electronics, C fibers can be activated by excessive pressure itself and chemicals released by damaged cells, such as crush injury, caused the weight of the device. This is important from a clinical stand point and future ability to wear the wearable electronic article, since after activation of C fibers, the next time that the user tries to wear an even lighter weight device in the same area, pain may result, a phenomenon called hyperalagia, preventing thus future use of the device for a potentially long period of time.

Receptors are discrete structures connected to nerve fibers and embedded in the skin. Although in some regions the density of receptors is very high, there are areas in which there are few receptors. The receptors in the skin of neck and ear, represented by anatomic areas supporting devices of the prior art, are very sensitive to mechanical stimuli, requiring displacements of only a few to tens of micrometers to excite them. When the stimuli is strong enough it can produce damage and become painful. By having proper weight and proper weight distribution, as per the present invention, the pain fibers of the anatomic areas supporting the weight are not activated and over time the pressure fibers, such as A β fibers, adapt to the weight, which allows absolute comfort during use.

As a way of illustration, but not of limitation, two anatomic areas of the body and their representative preferred embodiments, 1. wearable electronic head mounted gear including eyeglasses and hats, and 2. wearable computer, will be described. People who wear eyeglasses usually see indentation on the skin of the nose, but feel no significant discomfort. On the other hand, significant discomfort is felt when only minor mispositioning of temples occur around the ear. This occurs because the skin in the nose area has few pain receptors and C fibers, while the skin around the ear is more densely populated with pain receptors and C fibers.

It is possible to quantify the sensitivity of an anatomic area. The number of receptor locations for pain in the ear per square centimeter is in the range of 120 to 160 in comparison to the nose which is in the range of 35 to 55. The number of receptor locations for touch per square centimeter in the ear is in the range of 40 to 70 in comparison to the nose which is in the range of 90 to 110.

Even regular eyeglasses with conventional weight can cause discomfort around the skin of the ear if there is not a good fit because of the larger density of pain receptors in this area. Naturally, placing weight against the ear by temples housing electronics and/or power sources will likely elicit discomfort and pain over time. Therefore by mechanically displacing the weight to other areas that have less pain receptors and fibers, such as the nose, there is a reduction in the amount of pain receptors that will be activated, and an increase in the comfort level of the wearer. Furthermore, by distributing the weight into a larger area, such as by using a hat, there is less activation of pain fibers, and thus a heavier object can be used.

The number of receptor locations for pain in the neck per square centimeter is in the range of 170 to 200 in comparison to the shoulder and chest which is in the range of 120 to 150. Therefore by mechanically displacing the weight from the neck to other areas that have less pain fibers, such as the shoulder and chest, there is a reduction in the amount of pain fibers and receptors activated.

The problem of wearable devices is further compounded by the fact that a wearable device to be truly useful has to

be compact and interact with senses and biological functions of the body in a practical manner.

SUMMARY OF THE INVENTION

The present invention teaches a convergence between electronic products and the biological and anatomical aspects of the human body and biomechanics of the body while providing a series of hands-free wearable electronic apparatus that can interact with human senses and are biologically fit and provide a weight distribution that does not activate pain fibers (and cause pain).

A variety of wearable electronic devices are provided in the present invention including computing devices, video players, music players, and the like. One of the wearable articles of the present invention housing electronics includes eyeglasses.

The invention provides eyeglasses with an optimal distribution of weight in which the nose area supports more of the weight due to a counter-weight, represented by an electronic package, preferably positioned diametrically opposed to the nose in the back of the head with said electronic package being secured to the end of the temples of pair of eyeglasses. By displacing the weight to the back of the head and to the nose and housing only light weight parts in the temples, there is better weight distribution and comfort, with elimination or retardation of activation of pain fibers and reduction of pressure applied by temples directly against the anatomic area of the ear, which is more sensitive to pain caused by pressure than the nose area.

The invention further provides a better distribution of weight in which the shoulder and chest area supports the structure in combination with the neck, represented by an inverted U-shaped or an inverted V-shaped structure which has two arms resting against the shoulder and chest area in addition to the neck. By having two arms spaced apart there is spread of the weight with better balance and weight distribution across the neck and the shoulder and chest area.

The invention further teaches a weight distributed and biologically fit wearable computer. A variety of electronic parts and wireless parts can be integrated into the system. Accordingly, a cellular phone can be incorporated into the wearable computer with the dial pad being integrated into the keyboard, and hearing and voice function provided by the inverted U-shape structure while allowing hands free communication. Likewise, a wireless communication system for receiving communications over the internet can be integrated into the wearable computer of the invention or the storage cord of this invention.

The present invention provides a fully compact system when not in use, and which allows full interaction of the device with vision, hearing, speech, and tactile function while being used. The V-shape structure preferably is made of a flexible material which has memory including memory shape alloys. Therefore, when not in use (for instance when being carried or being placed on a table), the two ends of the structure can be folded upon each other and twisted in a helical shape placing the keyboard in one end of the arm on top of the display at the end of the opposite arm, creating a fully compact system. The present invention can also be used as a table-top, by having the helical shape being used with the vertical portion of the helical shape supporting the display in one end and the horizontal portion connected to the keyboard.

It is an object of the invention to provide detachable wearable electronic eyeglasses and head mounted gear with a plurality of electronic functions and interchangeable electronic function.

It is also an object of the invention to provide a wearable computer with optimal weight distribution and stretchable arms.

It is a further object of the invention to provide a plurality of hands-free wearable electronic devices including a video player, a music player, a video game, an electronic book, a global positioning system, a photo camera, a video camera, a television, a cordless phone, a cellular phone, and the like.

It is yet another object of the invention to provide hands-free support structure for housing electronics.

Eyeglasses are one of the most common wearable articles, and the majority of the adult population wears at least one of sunglasses or prescription eyeglasses for distance or for reading. It would be thus useful and desirable, as in accordance with this invention, to enable people wearing eyeglasses in general to have those eyeglasses perform an electronic function in a not noticeable manner and not seen by an external observer while keeping the frames light weight, elegant, compact, attractive, low cost and comfortable as well as biomechanically fit and practical for daily use in any situation of life. The eyewear of the invention doubles as an inconspicuous electronic device (besides having visual function as any eyeglasses), and since the eyeglasses of invention appear as regular eyeglasses, the eyeglasses can be used by the general population and for any occasion, such as at work, school, home, or during play.

These and other objects of the invention, as well as many of the intended advantages thereof; will become more readily apparent when reference is made to the following description taken in conjunction with the accompanying drawings.

BRIEF DESCRIPTION OF THE DRAWINGS

FIG. 1A is a perspective side view of a user wearing eyeglasses with a diagrammatic representation of the weight distribution using temples to house electronics according to the Prior Art.

FIG. 1B is a perspective side view of a user wearing eyeglasses with a diagrammatic representation of the weight distribution using a DEP (detachable electronic package) of the present invention.

FIG. 1C is a top perspective view of the detachable electronic eyewear system of one embodiment of the present invention.

FIG. 1D is a diagrammatic planar view of a preferred embodiment of the DEP.

FIG. 1E is a diagrammatic side view of a preferred embodiment of the DEP.

FIG. 1F is a diagrammatic side view of a preferred embodiment of a temple of eyeglasses of the invention.

FIG. 1G is a diagrammatic view of an ear bud assembly of the Prior Art.

FIGS. 1H and 1J are diagrammatic views of preferred embodiments of an ear bud assembly of the present invention.

FIG. 2A is a perspective front view of a user wearing a wearable electronic device around the neck with a diagrammatic representation of the weight distribution by the Prior Art

7

FIG. 2B is a perspective front view of a user wearing an inverted U-shape wearable electronic computer with a diagrammatic representation of the weight distribution of the present invention.

FIG. 3 is a perspective front view of the electronic eyewear of the invention with extended ear bud cords.

FIG. 4 is a perspective front view similar to FIG. 3 showing retracted ear bud cords and ear buds inside the temple of the eyeglasses.

FIG. 5A is a perspective front view of another embodiment of the detachable electronic eyeglasses of the invention.

FIG. 5B is a perspective side view of temple of the detachable electronic eyeglasses of the invention of FIG. 5A.

FIG. 5C is a perspective front view of yet another embodiment of the detachable electronic eyeglasses of the invention.

FIG. 5D is a perspective side view of temple of the detachable electronic eyeglasses of the invention of FIG. 5C.

FIG. 5E is a perspective view of a detail of the ends of the temples.

FIG. 6 is a perspective top side view of another embodiment of the detachable electronic eyeglasses system of the invention.

FIGS. 6A to 6D are perspective side views of a temple assembly attachment of the detachable electronic eyeglasses of the invention.

FIG. 6E is a perspective rear view of an exemplary DEP of the detachable electronic eyeglasses system of the invention.

FIG. 6F is a perspective side view of an exemplary temple assembly attachment of the detachable electronic eyeglasses of the invention when worn by a user.

FIG. 7 is a perspective back view of the detachable electronic eyeglasses system of the invention when worn by a user.

FIG. 8 is a perspective back view of another detachable electronic eyeglasses system of the invention when worn by a user.

FIG. 9 is a perspective side view of the detachable electronic eyeglasses system of the invention when worn by a user.

FIG. 10 is a perspective top view of the detachable electronic eyeglasses of the invention when worn by a user.

FIG. 10A is a perspective top view of the temple of the detachable electronic eyeglasses of the invention.

FIG. 10B is a perspective side view of the temple of the detachable electronic eyeglasses of the invention.

FIG. 11 is a perspective top side view of another embodiment of the detachable electronic eyeglasses of the invention.

FIG. 11A is a perspective side view of an exemplary electrical connection of another the detachable electronic eyeglasses of the invention.

FIG. 12 is a perspective top view of another embodiment of the detachable electronic eyeglasses system of the invention.

FIG. 12A is a perspective side view of another embodiment of the detachable electronic eyeglasses system of FIG. 12 when worn by a user.

FIG. 12B is a perspective top view of a three piece embodiment of the detachable electronic eyeglasses system of the invention.

FIG. 13 is a perspective front view of another embodiment of the detachable electronic eyeglasses system of the invention when worn by a user.

8

FIGS. 14A to 14C are perspective side top views of an exemplary temple assembly of the detachable electronic eyeglasses.

FIG. 14D is a perspective side view of an exemplary three piece embodiment of the detachable electronic eyeglasses system when worn by a user.

FIGS. 15A and 15B are perspectives side top views of another temple assembly of the detachable electronic eyeglasses.

FIGS. 16A to 16C are diagrammatic side views of the detachable electronic eyeglasses of the invention.

FIG. 17A is a diagrammatic side view of another temple assembly of the detachable electronic eyeglasses.

FIG. 17B is a diagrammatic back view of a temple assembly of the detachable electronic eyeglasses worn by a user.

FIG. 18A is a perspective back view of a slip-on assembly of the invention.

FIG. 18B is a perspective side view of a slip-on assembly of the invention.

FIGS. 19A and 19B are diagrammatic side views of a slip-on assembly of the invention.

FIGS. 20 and 21 are diagrammatic side views of another slip-on assembly of the invention.

FIG. 22A is a perspective front view of a clip-on assembly of the invention.

FIG. 22B is a perspective side view of the clip-on assembly of FIG. 22A.

FIG. 22C is a perspective side view of the clip-on assembly of FIG. 22A when worn by a user.

FIG. 23 is a perspective side view of another clip-on assembly when worn by a user.

FIG. 23A is a perspective top view of a clip-on assembly when worn by a user.

FIG. 23B is a perspective side view of another clip-on assembly when worn by a user.

FIG. 23C is a perspective side top view of another clip-on assembly connected to a DEP.

FIGS. 24A and 24B are diagrammatic side views of a temple assembly of the invention.

FIG. 24C is a diagrammatic side view of an exemplary latch mechanism of the temple assembly of the invention.

FIG. 24D is a perspective side view of another temple assembly of the invention.

FIGS. 25A and 25B are perspective side views of another temple assembly of the invention.

FIG. 25C is a side view of an electronics assembly housed in a temple.

FIGS. 26A to 26C are diagrammatic side views of another temple assembly of the invention.

FIG. 27 is a diagrammatic top view of the temple assemblies and DEP of detachable electronic eyeglasses system of the invention.

FIG. 28 is a diagrammatic top view of a kit containing temple assemblies and DEP.

FIG. 29 is a diagrammatic top view of a DEP.

FIG. 30 is a diagrammatic top view of a kit containing detachable electronic eyeglasses and DEP.

FIG. 30A is a diagrammatic top view of a kit containing detachable electronic cap and DEP.

FIGS. 31A and 31B are perspective side views of another temple assembly of the invention.

FIG. 32 is a perspective top view of another embodiment of the detachable electronic eyeglasses of the invention.

FIG. 32A is a perspective top view of a temple assembly of the detachable electronic eyeglasses of FIG. 32.

FIG. 33 is a perspective front top view of another embodiment of the detachable electronic eyeglasses of the invention.

FIG. 33A is a perspective side view of a temple assembly of the detachable electronic eyeglasses of FIG. 33.

FIG. 34 is a perspective back view of the detachable electronic eyeglasses cord of the invention.

FIG. 34A is a perspective side view of the detachable electronic eyeglasses cord of the invention when worn by a user.

FIG. 34B is a perspective side view of another exemplary cord assembly of the detachable electronic eyeglasses.

FIGS. 34C TO 34H are various exemplary embodiments of Bluetooth enabled systems cooperating with eyeglasses or other wearable articles.

FIGS. 34J TO 34V illustrate various specialized storage cords.

FIG. 35 is a perspective side view of a camera embodiment of the detachable electronic eyeglasses system of the invention when worn by a user.

FIG. 36 is a diagrammatic side view of a detachable electronic head mounted gear system of the invention.

FIG. 37 is a perspective side view of a detachable electronic head mounted gear system of the invention.

FIG. 37A is a diagrammatic top view of the wire, spools, and connector assemblies of FIG. 37.

FIG. 37B illustrates head mounted gear

FIG. 37C illustrates detachable electronic goggles.

FIG. 38 is a perspective side view of a detachable electronic clothing system of the invention.

FIG. 39 is a perspective side view of a shoulder mount wearable electronic article of the invention.

FIGS. 39A and 39B are perspective side view of another shoulder mount wearable electronic article of the invention.

FIG. 40 illustrates a weight distributed anatomically fit wearable computer.

FIG. 41 illustrates a wearable computer and extendable portion.

FIGS. 42A and 42B illustrate adjustable extendable portions of the wearable computer system.

FIGS. 43A to 43H show a plurality of exemplary embodiments illustrating an extendable portion of an inverted U-shape computer.

FIGS. 44A through 44D illustrate various embodiments of a clasp assembly.

FIGS. 45A through 45C illustrate different heights of keyboard actuation.

FIGS. 45D through 45G illustrate a spinal configuration for a wearable computer.

FIGS. 46 and 47 illustrate use of a wearable computer by a user.

FIG. 48 shows a rotating wheel assembly.

FIG. 48A shows a rotatable keyboard assembly.

FIG. 49 illustrates an alternate embodiment of a wearable computer.

FIGS. 50A through 50C illustrate a shoulder holster wearable computer.

FIGS. 50D and 50E illustrate various views of a flexible and extendable gooseneck extension.

FIGS. 51 and 51A illustrate a foldable keyboard.

FIG. 52 illustrates a wearable CD player.

FIG. 53 illustrates a wearable DVD player

FIGS. 54, 54A and 54B illustrate a detachable wearable telephone.

FIGS. 55A through 55D illustrate a U-shape support structure.

FIGS. 56 through 60 illustrate a C-shape tubular support structure.

FIG. 61 illustrates a storage cord according to the present invention.

FIGS. 62 through 71 illustrate various embodiments of the storage cord according to the present invention.

FIGS. 72 through 76A illustrate various alternate embodiments of a storage frame for an electrical component.

FIGS. 77 and 78 illustrate an anatomically correctly shaped telephone.

FIGS. 79A through 80C illustrate alternate embodiments of storage cords.

FIGS. 81A through 81F illustrate a connection stabilizer for an electronics device.

FIGS. 82 and 83 illustrate an anatomically fit electronics package.

FIGS. 84A through 84D illustrate a flip style digital music player.

FIGS. 85A through 87F illustrate alternate embodiments of a storage cord according to the present invention.

FIGS. 89A through 89C illustrate alternate embodiments using elastic to contain an electronics device and a storage cord.

FIGS. 90 and 91 illustrate a storage cord mounted on a headband.

FIGS. 91A through 98 illustrate a connection clip and its use for supporting various styles of storage cords.

FIG. 99 illustrates the permanent attachment of a storage cord to a wearable article.

FIGS. 100A through 100F illustrate a storage cord made of a rigid material.

FIGS. 101A through 101D illustrate a rigid attachment appendage.

FIGS. 102A through 102C illustrate the mounting of an electronics device on a storage cord.

FIG. 103 illustrates the mounting of a Bluetooth receiving device on a storage cord.

FIGS. 104A through 106B illustrate the mounting of an electronics device on a storage cord for receiving signals to control the electronic device.

FIG. 107 illustrates an alternate embodiment of the storage cord.

FIGS. 108A and 108B illustrate a remote control for use with the embodiments of FIGS. 106 and 107.

FIGS. 109 through 112 illustrate alternate embodiments of storage cords.

FIGS. 113 through 120 illustrate alternate mechanisms for attaching a storage cord to an article of clothing.

FIGS. 121A through 121E illustrate a storage cord assembly pocket.

FIGS. 122A through 122D illustrate a storage cord assembly.

FIGS. 123A and 123B illustrate a cell phone having connecting arms.

FIGS. 124A through 125 illustrate connecting arms located on the rear of a chair.

FIGS. 126A through 126C illustrate a support platform for a storage cord assembly.

FIG. 127A through 128K illustrate alternate embodiments of a platform for a storage cord assembly.

FIGS. 129A through 131 illustrate a curved telephone and demonstrate how it would be worn by a user.

FIGS. 132A and 132B illustrate a telephone with pivotally mounted arms.

FIG. 133 through 137 illustrate a neck mounted telephone.

FIG. 138 illustrates a curved telephone handset.

FIG. 139 illustrates an alternate embodiment of a storage cord assembly.

FIG. 140 illustrates a rigid C-shaped neck support.

FIGS. 141 through 145 illustrate various arrangements for mounting a storage cord assembly adjacent to the face of a wearer.

FIGS. 146A through 167C illustrate the mounting of a cold/hot pack on a wearer using various storage cord assemblies.

FIGS. 168 through 169B illustrate a retractable cord assembly.

FIG. 170 illustrates an alternate embodiment of a storage cord assembly.

FIGS. 171A through 183E illustrate alternate embodiments for mounting of a storage cord assembly on an article of clothing.

FIGS. 184A through 196E illustrate alternate embodiments for mounting a storage cord assembly on the temples of eyeglasses or other article of clothing.

FIGS. 197A through 197H and 197J through 197R illustrate a shoulder supported inverted U-shape structure to be worn and supported on the shoulder of a body.

FIGS. 198A and 198B illustrate a two-part storage cord assembly.

FIGS. 199A and 199B illustrate a memory controlled device separable from an electronics device and mountable on a storage cord assembly.

FIG. 200A illustrates a preferred embodiment of the present invention including a support structure for a specialized storage frame.

FIG. 200B illustrates a preferred embodiment of a storage cord assembly.

FIG. 200C illustrates a preferred embodiment of an alternate storage cord assembly.

DETAILED DESCRIPTION OF THE PREFERRED EMBODIMENTS

In describing a preferred embodiment of the invention illustrated in the drawings, specific terminology will be resorted to for the sake of clarity. However, the invention is not intended to be limited to the specific terms so selected, and it is to be understood that each specific term includes all technical equivalents which operate in similar manner to accomplish a similar purpose. Electronic package and electronic device may be used interchangeably.

Besides eyeglasses, a variety of other wearable articles such as head mounted gear, hats, eye masks, helmets, visors, neck mounted gear, scarves, garments, and the like are commonly worn on the body but are not electronically enabled and not biomechanically fit for wearable electronics. It would be desirable, as in accordance with the present invention, to provide electronic capabilities to such wearable articles and fit an electronic system into such wearable articles with proper weight distribution while keeping such articles low cost, comfortable, elegant, and easy-to-manufacture, with the electronics and electronic package being confined to the dimensions of the wearable article and being not visible to an external observer while providing vision, voice, and hearing interaction between the wearer and the device.

The present invention includes a miniaturized electronic system which fits into a wearable article (such as eyeglasses, head mounted gear such as hats, neck mounted gear and garments) without significantly altering the wearable article. This is accomplished by reducing the number of parts of the electronic system that are permanently housed in the wear-

able article. The rest of the electronic system is included in a detachable electronic package (DEP) that can be attached to the wearable article in a way not to be visible to an external observer. The invention also eliminates the need for accessories such as ear buds, and reduces the number of the most expensive and heavier parts that are permanently affixed to the wearable article.

The present invention provides a wearable electronic article which comprises a DEP and a wearable article (WA) detachably connected to the DEP. Preferably, the connection between the DEP and the wearable article includes an extendable cord, most preferably a spool with retractable wires or a coiled wire capable of elongation and with spring capabilities. The DEP is releasably connected to an electrical connection in the wearable article (also referred as WA). The WA will also typically have electrical connections for ear buds, which are preferably permanently affixed to the WA. Preferably, the ear buds are connected to a spool with retractable wires or to a coiled wire capable of elongation and with spring capabilities. The DEP can include a variety of electronic devices such as digital music player, wireless communication devices, video player, video recording, Global Positioning Systems (GPS), and the like.

By way of illustration, and not by way of limitation, a preferred embodiment of the invention comprising eyeglasses will be described in detail. The detachable electronic eyeglasses system comprises a DEP having two wires preferably disposed on opposite ends of the DEP. These wires have electrical connections at their free ends which are releasably connected to electrical connections contained in the frame of a pair of eyeglasses.

The eyeglasses which are part of the claimed system comprise a front portion housing lenses and two temple portions disposed on opposite ends of the front portion. Each temple portion preferably houses a wire, an ear bud, and an electrical connection. The earbud is preferably hidden away within the frame structure or, most preferably, at the end of the frame. The dimensions of the ear buds are preferably confined to the dimensions of the frame. The electrical connection in each temple is releasably connected with the wires on the DEP. The connections within the temples are standardized so that different DEP's can be used in connection with the glasses, and the user has the option to choose a plurality of electronic packages using the same eyeglasses frame.

The electrical connections of the temples of the eyeglasses connect with the electrical connections of the DEP, forming a circuit through the DEP. No wires need be run through the hinges connecting the temple portions to the front portions of the frames.

The temple portions are adapted to secure or house electrical connections, wires, and an ear bud. Although the preferred embodiment preferably includes temples housing a wire, ear bud, and an electrical connection, it is understood that other parts including light weight and small microchips, or a small power source can be secured to or housed in said temples. It is also understood that the temples can include other parts such as micro optics for a camera such as for video or pictures, a light source, or a microphone while the main and heavy electronics are housed outside the frames, preferably in the DEP. For example, an eyeglass frame of the current invention for video recording could include the micro optics of a camera housed within the frame of the eyeglasses and the main electronics housed in the DEP. The lens, aperture, and a small image sensor, such as a Charge Coupled Device and user interface (such as control buttons)

could be housed in the frame while the controls, processor, power source, circuits, and LCD screen are housed in the DEP.

In a preferred embodiment, the temples house the wires within the structure of the temples, with one end of said wire connected to an ear bud or to an electrical connection for an ear bud, and the opposite end of the wire having an electrical connector. Preferably, the electrical connector is located in the end portion of each temple, and most preferably at the free end of each temple. Alternatively, the wire can be secured to the temple on top of the surface of the temple and not within the structure of the temple. This allows for an easier manufacturing process, particularly in the case of thin frames. Although the electrical connectors are preferably housed at the end of the temples, it is understood that the electrical connectors can be placed in any part of the frame, including the mid part of the temples.

The electrical connection at the end of the temple has means to be connected to another electrical connection, preferably one from the DEP. The electrical connectors at the free end of the temples are preferably connected to the free end of the wires which are connected to the DEP. To ensure a secure electrical connection between the DEP and the eyeglass frame, there is preferably a latching mechanism between the DEP and the eyeglass frames or the temples. It is understood that any mechanism for securing the DEP to the eyeglasses frame can be used.

The electrical connectors in the frames of the eyeglasses are adapted to connect with a plurality of electronic devices housed in the DEP including a MP3 player, Bluetooth device, radio, video player, video recorder, voice recorder, game device, television, computerized electronic organizer, a radio reflective system, a Global Positioning system, a light source, and a cellular phone. The DEP can also include digital storage for a digital binocular for example with the binocular optics mounted in the frame of the eyeglasses and electronics and memory stored in the DEP. The invention creates eyeglasses enabled for an electronic function in which the same eyeglasses frame can receive a plurality of electronic capabilities depending on the attached DEP.

Thus, the invention provides electronically enabled eyeglasses for multiple functions without having to change the eyeglasses frame. The same discrete, light weight, elegant, and not noticeable electronic eyeglasses can play music and video or alternatively receive a phone call simply by replacing the type of DEP, in addition to replacing one DEP with one electronic function by another DEP with another electronic function, the present invention is also versatile and two or more electronic devices can be housed in the same electronic package. The DEP is used for a specific period of time for that function, and then either stored or replaced by another DEP after the function is completed. For example a larger DEP can include a MP3 player and a digital video player when the user wants to see and hear, or the DEP can be real light weight when the user wants only Bluetooth capabilities, with such a DEP including a microphone. It is understood that a DEP with multiple electronic functions can be used and thus only one DEP may be necessary.

The present invention allows any eyeglasses and head mounted gear (such as a hat or headband) to be electronically enabled including for delivering sound and video, without an added expense related to electronics and without creating a bulky and heavy head mounted gear. The manufacturing process is simple and cost effective, and in the case of eyeglasses includes only changing the temples, which houses a minimum amount of light weight and thin parts and with no buttons in the frame, thereby allowing use of

eyeglasses which looks like conventional eyeglasses. Whenever the user wants to listen to music, watch a video, play a game, or answer a cell phone, all functions are at the finger tips by simply electrically connecting the DEP to the frame of the eyeglasses or other head mounted gear. The DEP can also include a wireless transmitter for transmitting a biological measurement by eyeglasses and head mounted gear, as described in U.S. Patent Published Application Nos. 20040059212 and 20040242976.

The present invention also provides an electronic clip-on and a slip-on system which comprises a specialized clip-on of special dimensions with electronic capabilities and wiring for connecting one end of the clip-on in one temple with the opposite temple without going through a hinge mechanism or having the wire bent. The specialized clip-on and slip-on for frames of eyewear includes specialized retractable ear buds and electrical connections of special dimensions. It is also understood that the clip-on and slip-on embodiment can include a dual side clip-on or slip-on which houses ear buds in both sides (right and left), and one side houses electronics and power source, with said both sides (right and left) of the clip-on being electrically connected by a cable that extend along the back of the head or neck of the wearer.

It will be appreciated that the features of the invention optimize the use of head mounted gear and the frame of eyeglasses to be used as means to deliver sound and video to a user, without changing the comfort, style, and weight of the eyeglass frames, since the heavy, bulky, and cumbersome electronics are not housed in the frames. The present invention optimizes all areas by allowing the user to wear regular eyeglasses and other head mounted gear while allowing enjoyment of sound and video with specialized temples housing special ear buds with retractable cords.

The invention provides an entirely new approach for electronic apparatus and wearable electronics and provides numerous advantages including:

1. Extending the life of the electronics package because the electronics package is detachable from a short-lived WA that has a short life;
2. Extending the life of the WA because a broken or obsolete electronics component can be replaced with a new one, allowing for continued use of the WA;
3. Preserving and enhancing the comfort and usability of the WA, because the electronics need only be secured to the WA when the electronic function is being used;
4. Enhancing usability and preserving elegance and comfort of the wearable electronics since the electronics are small and confined to the dimensions of the WA;
5. Preserving elegance and function of the WA because the electronics and other parts are not visible to an external observer and the electronics, wires, and ear buds do not alter or distort the WA;
6. Expanding the utility of the DEP because the same DEP can be coupled with a variety of WA's such as eyeglasses, hats, helmets, visors, eye masks, and the like;
7. Increasing the durability of the DEP by keeping it away from the WA during situations that put the electronic package at risk of damage such as during cleaning of the WA;
8. Enhancing usage by providing a system that permits a user to experience each of vision, speech, and hearing in conjunction with as wearable electronic device;
9. Expanding the utility of a WA, which now can perform an electronic function;
10. Increasing the value of a WA, which while still very low cost is able to perform an electronic function;

11. Enhancing convenience of use of the system by eliminating the need to carry and store key accessories such as ear buds;

12. Limiting the possibility of the DEP being easily stolen or forgotten by the electronic device being felt at all times and worn on the surface of the body;

13. Increasing the adaptability of the DEP for people of any size and weight, because the DEP can universally fit any size of wearable articles; and

14. Natural usage of the electronics by the electronics being held in position due to gravity and support of a body part and without the need of fastening the electronic device to the body.

A further example of a possible user of an embodiment of the present invention involves a doctor. Ordinarily, it would not be acceptable for a doctor to wear heavy and bulky eyeglasses with visible electronics, buttons, or ear buds, as found in the prior art, because such features would be noticeable to a patient who is being examined. Such eyeglasses—which could be perceived as weird or frightening—could take away the seriousness of the doctor-patient relationship, and would not be helpful—or even, in some cases, permitted—at hospital or during delivery of health care. (This is also likely the case in any serious working environment or at school.) Furthermore, such weird and bulky eyeglasses could create unnecessary distraction to others. Since the eyeglasses (and other head mounted gear) of the present invention serve as an inconspicuous electronic device, such as a music player, the doctor could, for example, carry a DEP for playing music. During lunch, the doctor may wish to listen to some music, and connects the music playing DEP to the frames. He or she can then pull out the retractable ear buds from the temples of the eyeglasses and place them on the ears. The doctor may then, in a unremarkable manner, enjoy music since the only apparent parts are small ear buds. The DEP is camouflaged in the back of the head almost as regular cords for holding eyeglasses on the head. In order to better hide the DEP, the wires and system can be preferably encased in neoprene, leather, fabric, or similar material not easily visible. After the doctor finishes lunch, he/she allows the ear buds to retract back into the temples, disconnects the DEP from the temples, and puts the DEP away in a pocket. Immediately, the electronically capable eyeglasses look like regular eyeglasses without any cord hanging from the temples.

The doctor could also, for example, keep the DEP connected to the frames. Because the DEP is hidden behind the head and is unobtrusive, it would not hinder the doctor in his or her work or get in the way of examining patients. By keeping the DEP connected to the frames (or changing to a different DEP, such as a camera enabled DEP), the doctor could take advantage of a small camera system housed in the frames while bulky electronics, circuit, and digital storage are housed in the DEP. This could allow the doctor to photograph portions of a patient's body, for example, a cancer lesion, simply by using eyeglasses already worn by the doctor. The photograph is stored in the DEP, and can be uploaded to a computer or television for analysis or storage. The eyeglasses can also be enabled with silicon microdisplay capabilities on the lens to permit the doctor to see the image to make sure the stored image includes all aspects required.

The doctor can use the DEP MP3 during lunch, the DEP camera for work, and a Bluetooth enabled telephone when going home. The eyeglasses can, therefore, provide multiple electronic functions. After getting home, the doctor may still need the eyeglasses for vision correction, but not for any

further electronic functionality. Thus, the doctor puts the ear buds back in the temples and disconnect the DEP. With the ear buds hidden in the temples and no DEP connected, the eyeglasses turn into conventional eyeglasses.

Having eyeglasses with hanging and noticeable ear buds and electronics housed in the frame the whole time as provided by the prior art sends a message that the primary interest of that wearer is to listen to music or other things, not human voice. With the eyeglasses system of the invention, the user when comes back home can disconnect the DEP and hide the ear buds, and by wearing regular looking eyeglasses indicate interest in listening to people. After dinner, the doctor plugs the DEP Digital Video Player and using the retractable cord attached to the DEP places the display in front of the eyes and watches a video. Before going to bed, the user plugs in an audio player/recorder audio player into the eyeglasses and listens to a speech which was recorded while the user was wearing the eyeglasses with built-in microphone. Since the digital storage, battery, and electronics are housed in the DEP, only a 1 mm in diameter microphone and a thin wire are housed in the structure of the eyeglasses frame, making the microphone assembly be barely visible.

The same DEP can be used with a variety of different WA's. For example, when the user goes to bed, the user who wants to sleep at the sound of music, grabs the same DEP MP3 used during lunch time at work, but the same DEP MP3 is now plugged into the eye mask instead of the eyeglasses. The user then places the ear buds from the eye mask on to the ears, covers the eyes with the eye mask, turns on the system, and goes to sleep at the sound of a soothing music. After waking up in the morning, the user plugs an MP3 player into an electronically enabled cap, and now the user can exercise while listening to music from a DEP attached to an electronically enabled cap.

Similarly, the user can wear an inverted U-shape wearable PC to the airport. While listening to music with the electronic eyeglasses, the user works on a PowerPoint presentation using the inverted U-shape wearable computer while waiting on security lines and waiting for the flight. During the flight, the user uses the inverted U-shape wearable PC to do work and watch a movie. The keyboard and display of the inverted U-shape PC can virtually "float" in the air at any height due to the self-adjusting extendable arms. Therefore, if a meal is served during the flight the user does not need to close the computer and stop viewing the movie or doing work. The keyboard is moved up and positioned over the tray table while the meal is placed on the tray table, allowing continued viewing of a movie or doing work without interruption during the meal. This closes a 24 hour cycle for a user wearing different wearable electronic devices for different activities and electronic functions.

Because the electronics are detachably connected to the WA's such as the eyeglasses, hat, and eye mask, the WA's can be cleaned and washed without jeopardizing the sensitive electronics, and when discarding the WA, the user can keep expensive electronics and reuse in another WA adapted to receive the electronic package.

The present invention also includes a method of using wearable electronics, comprising the steps of (1) affixing electrical connectors and wires to a wearable article, (2) electrically connecting in a releasable manner the electrical connector of the wearable article to a detachable electronics package resting against the structure of the WA, (3) activating an energy source to power the detachable electronic package, and (4) delivering at least one of sound or visual signal to the user through the wearable article.

17

A further aspect of the invention is a method of using a wearable computer, the wearable computer being an inverted U-shape PC with two arms combining an adjustably extendable portion (such as goose neck portion) and an adjustably positionable portion (such as a spinal or accordion portion) said method comprising the steps of:

- a) connecting a keyboard to one arm,
- b) connecting a display to the opposite arm,
- c) creating a wired or wireless connection between the display and the keyboard,
- d) activating a power supply, and
- e) generating a processing function housed in either the display or keyboard.

Alternatively, the steps could include:

- a) connecting a keyboard to one arm,
- b) connecting a display to the opposite arm,
- c) connecting a processor to the keyboard and/or display,
- d) creating a wired or wireless connection for connecting the display, the keyboard, and processor
- e) activating a power supply, and
- f) generating a processing function in the processor part.

The invention further comprises a method of playing a DVD on a wearable device comprising the steps of:

- a) connecting a disc player to one arm,
- b) connecting a display to the opposite arm,
- c) connecting a power supply to the display and/or disc player,
- d) creating a wired or wireless connection for connecting the display, the disc player, and power supply,
- e) activating the power supply, and
- f) generating an electronic function in the disc player.

The invention further comprises a method of playing video games on a wearable computer, comprising the steps of:

- a) connecting a video game control to one arm,
- b) connecting a display to the opposite arm,
- c) connecting a processor to the display and/or video game control,
- d) connecting a power supply to the processor,
- e) creating a wired or wireless connection for connecting the display, the video game control, the processor, and the power supply,
 - i) activating the power supply,
 - ii) generating an electronic function in the processor, and
 - iii) generating at least a visual signal in the display.

A further embodiment of the invention is a method of watching images using a wearable system comprising the steps of:

- a) securing an imaging device to the end of the adjustably flexible arm (such as a gooseneck arm) of a support structure combining an extendable portion (such as an accordion or spinal portion) and a flexible portion (such as a gooseneck portion)
- b) positioning the support structure around a portion of the body,
- c) elongating the stretchable arm secured to the imaging device,
- d) positioning the imaging device within the visual axis of the eye,
- e) activating a power supply,
- f) generating an electronic function in the imaging device, and
- g) generating a visual signal in the imaging device.

The invention also comprises a method for using a hands-free wearable electronic device comprising the steps of:

18

- a) securing an electronic package to the end of an arm of a support structure combining an extendable accordion portion and a flexible gooseneck portion,
- b) positioning the support structure around a portion of the body,
- c) elongating the extendable portion of the support structure,
- d) adjusting the arm to position the electronic package in line with the eyes,
- e) activating the power supply, and
- f) generating an electronic function in the electronic package.

The invention further includes a method for turning commonly WA into articles with electronic capabilities including the steps of securing an electronic package to a storage cord, attaching the storage cord to the WA, activating a power supply, and generating a function in the electronic package secured to the WA.

Other features, benefits, and advantages of the invention will appear from the following description in conjunction with the accompanying drawings.

FIG. 1A shows an electronically-enabled pair of eyeglasses from the prior art. Electronics 1 are housed in temples 2 of the eyeglasses, or in the area adjacent to nose bridge 3. Arrow A represents the large amount of weight that is placed directly against the skin of ear region 2a, thereby promoting activation of pain fibers along the ear and provoking user discomfort. Also, with electronics 1 in temples 2, nose bridge 3 is weighed down, as represented by arrow B. This creates further discomfort, by encouraging the eyeglasses to slide down the wearer's nose.

FIG. 1B shows an illustration of a preferred embodiment of the present invention. DEP 4 is positioned at the back of the head, preferably opposite to nose bridge 3. Temple 5 is thin, light weight and has no internal electronics. A second temple on the other side of the head is not shown. Ear bud 6 is connected to temple 5 by light weight coiled wire 7. The vector force, represented by arrow C, pulls the frame downward and applies a force to displace nose bridge 3 perpendicular to the plane of the face, represented by vector D. This transfers support of the eyeglasses to the nose, which is a less sensitive area than the ear, by reducing the weight applied to the ears (represented by smaller arrow F). This limits the activation of pain fibers in the more sensitive anatomic region of the ear.

FIG. 1C shows a top perspective view of a detachable electronic eyewear system of the invention. Detachable wearable electronic system 10 of the invention comprises electronic eyeglasses frame 30 and detachable electronic package (DEP) 20. Detachable electronic eyeglasses frame 30 has two lens rims 58 and 60 and two temples, right temple 14 and left temple 16. Lens rims 58 and 60 can hold any type of lens (e.g. prescription, tinted, bifocal, clear, etc.). Right and left temples 14 and 16 each comprise two portions, right and left front portions 52 and 56 and right and left end portions 13 and 11. Front portions 52 and 56 define portions which are intended to extend along the side of user's head to the user's ear. Right and left end portions 13 and 11 include right and left free ends 37 and 35. Right end portion 13 preferably houses right ear bud 40, right coiled wire 48, and right connecting wire 50. Right connecting wire 50 connects ear bud 40 with coiled wire 48. Left end portion 11 preferably houses left ear bud 44, left coiled wire 46, and left connecting wire 54. Coiled wires 48 and 46 can elongate and retract and have spring capabilities. Alternatively coiled wires 48 and 46 can be secured to small spring loaded wheels or spools 15 and 17 with retracting capabilities. Either option allows ear buds 40 and 44 to be easily retracted

19

for use and put back and hidden in temples **14** and **16** after use. Free ends **35** and **37** define ear portions which are shaped for placement around the wearer's ears. Free end portion **37** includes right electrical connector **36** and right wire **38** that connects right electrical connector **36** to ear bud **40** through wire **50**. Free end portion **35** includes left electrical connector **34** and left wire **42** that connects left electrical connector **34** to ear bud **44** through wire **54**.

Detachable electronic package (DEP) **20** is intended to extend across the neck or the back of the wearer's head and includes an electronics package **12**, right cord **18** and left cord **22**. Preferably right cord **18** and left cord **22** are disposed on opposite ends of electronic package **12**. Right cord **18** houses right wire **26** which has electrical connection **28** on its end which can be releasably connected to electrical connection **36** of right temple **14**. Left cord **22** houses left wire **24** which has an electrical connection **32** on its end which is releasably connected with electrical connection **34** of left temple **16**. Electronics package **12** includes display **68**, memory **62**, power source **67**, standard control buttons **66** such as play, stop, forward, and rewind and volume control, and conventional entry ports **65** for USB or computer connection for downloading/uploading as well as circuit board and microchips (not shown) well known in the art for controlling operations. Memory **62** may comprise known systems such as a flash memory or a hard drive. Electronics package **12** further includes retractable cord **71**, which is preferably secured to a spring loaded wheel or spool **70** with retracting capabilities. This allows the electronics package to be easily pulled for use and put back and hidden in the back of the head after use. Display **68** can, for example, show the name of music being played or it could show a movie, by being brought from the back to the head into the visual axis of the eyes by extending retractable cord **71**. Alternatively, instead of having wire **71** secured to spool **70**, the DEP can have a coiled wire with retracting capabilities that can elongate for viewing the DEP and retract to its original position after use.

Electronics package **12** is preferably kept hidden behind the head, out of sight of the wearer as well as an external observer. Accordingly, control buttons **66** preferably have raised features or special positioning to allow the user to easily identify and use buttons **66** when electronics package **12** cannot be seen by the user. For instance, on the top part of electronics package **12** the first button (e.g., press button) is stop, the second button is pause, and the third button is play. On the bottom part of electronics package **12** the first press button is rewind and the second is forward while a dial type button functions to change volume. Alternatively, a dial looking button such as is found in digital music players (eg. iPod of Apple Inc.) can be used.

In addition to ear buds secured to coiled cords capable of elongation and with spring capabilities, the invention can also use a spring loaded spool cord of special dimensions and length, and with retractable extension. The preferred diameter for ear bud cord is less than 2.5 mm, and preferably less than 1.5 mm and most preferably less than 1 mm in diameter. The preferred length for ear bud cord is equal to or less than 20 cm, and preferably equal to or less than 16 cm and most preferably equal to or less than 10 cm in length. The preferred combined length of right wire **26** and left wire **24** connected to electronics package **12** is equal to or less than 45 cm in length, and most preferably equal to or less than 35 cm in length, and even most preferably equal to or less than 30 cm in length. It is also understood that in order to make the DEP smaller and lighter, passive means for

20

powering the DEP can be used, in which the DEP receives energy from a remote source by electromagnetic induction, radio waves, and the like.

FIG. 1D shows a top view of a preferred embodiment of DEP **20** that includes a cradle-like housing **72** that defines a cavity **74** sized to accept and retain in a releasable manner electronics package **12**, such as a digital music player, radio, cellular phone, a Global Positioning System, a personal digital assistant (e.g., Palm electronic organizer from Palm, Inc.), and the like. Release button **69** on the right side of housing **72** facilitates attaching and releasing electronics package **12** from the housing **72**. Preferably, release button **69** is a spring-loaded mechanism that engages and retains a portion of electronics package **12** when in cradle cavity **74**, and permits releasing the electronic package when needed. Right cord **18** and wire **26** have an electrical connector **28** at the free end, enter housing **72** in the right side, and connect with right wire **73** housed inside cavity **74**. Wire **73** is connected to spool **70**. Left cord **22** and wire **24** have an electrical connector **32** and enter housing **72** on the left side and connect with left wire **75** housed inside cavity **74**. Wire **75** is connected to spool **70**. Wires **73**, **75** and spool **70** inside housing **72** are shown as broken down lines.

FIG. 1E shows a side view of DEP **20** that includes cradle-like housing **72** that defines recess **74** sized to accept and retain in a releasable manner electronics package **12**. Release button **69** holds electronics package **12** in recess **74**. Spool **70** at the base of the cavity **74** has coiled wire **77**, which is in electrical contact with right wire **73** and left wire **75**. Coiled wire **77** is connected to electronic package **12** and works as a retractable/extendable wire via spool **70** to allow the user to bring the electronics package **12** from the back of the head to the visual axis of the eyes of the user by extending retractable wire **77**. After looking at electronics package **12**, the user may actuate spool **70**—for example with a gentle pull—retracting retractable wire **77** and bringing electronic package **12** back to cavity **74**. Electronics package **12** includes display **68**, key pad **79**, microchip circuit **78** and battery **67**. It is understood that in order to make electronics package **12** smaller and thinner, power source **67** and microchip circuit **78** and other hardware may be housed in housing **72**. Wire **73** is in electrical connection with wire **26** and electrical connector **28**. Wire **75** is in electrical connection with wire **24** and electrical connector **32**. This embodiment illustrates the use of a retractable wire system. However, it should be understood that a non-coiled wire wrapped around a spring-loaded mechanism would provide the same functionality, as could other arrangements. Although a release button is a preferred embodiment, it will be understood that a release button is not necessary, and that the force of the spring can be used to anchor the electronics package in the cavity.

Electronics package **12**, which can be, for example, a digital music player or cell phone, is connected to housing **72** of DEP **20** with retractable wire **77** secured to a spool **70**. This allows the user to interact visually with electronics package **12**, and provides interaction with the key biological function of vision, notwithstanding the fact that electronics package **12** is housed completely away from the eyes of the user. Therefore, for example, the invention allows a user wearing a DEP digital music player to extend retractable cord **77** until electronics package **12**, illustrated as a MP3 player, can be seen by the user. The user can then view display **68** and make the selection of music of interest using buttons **79**. After making a selection, the user can release wire **77**, which retracts MP3 player **12** back into cavity **74** in the back of the head and hidden away. Likewise, if

21

electronics package 12 is a cellular phone, the wearer can extend retractable cord 77, dial using key pad 79, and then return the DEP (cell phone) to the back of the head and away from sight from an external observer.

It will be understood that an electrical connection for an ear bud disposed in the temples of the eyeglasses can be used. Therefore, as shown in FIG. 1F, temple 19a includes a first electrical connector 21 disposed in end portion 19 for connecting to an electronic device. Temple 19a also has a second electrical connector 23 adjacent to first electrical connector 21 for an ear bud. Electrical connector 21 is, in this embodiment, a female connection used to connect DEP 21a. Second electrical connector 23 for connecting with ear bud assembly 23a, is also, in this embodiment, female. Wire 25 connects first electrical connector 21 with electrical connector 23. The same structure can be used for the opposite temple.

FIG. 1G shows a prior art system, which provides ear buds for stereo sound comprising ear buds 27 and 29 connected by wires 31 and 33, which combine to form wire portion 39, which terminates at electrical plug 121. Electrical plug 121 is removably connected to prior art electronic device 121a, which has a single jack 121b to connect with electrical plug 121. Because the prior art did not converge the ear bud system with the anatomy of the user's body, only one jack 121b is provided in the electronic device 121a and excessively long wires are needed with a usual length from ear buds 27 and 29 to plug 121 being more than 90 cm.

By contrast, one aspect of the present invention is a specialized ear bud system for stereo sound. By adapting the electronics to human anatomy, ear buds with very short wires can be used. As shown in FIG. 1H, ear bud system 41 for stereo sound comprises two separate ear bud assemblies 43 and 45. Each ear bud assembly 43 and 45 includes ear buds 43a and 45a, electrical plugs 85 and 87 and a coiled wires 47 and 49, which can elongate for placement on the ears. The preferred length of wires 47 and 49 is equal to or less than 15 cm, more preferably equal to or less than 12 cm in length, and most preferably equal to or less than 10 cm in length. This compares with the 90 cm length of the prior art wires.

Each ear bud 43a and 45a has a plug 85 and 87 which is releasably connected to electrical connector 51 and 53. Connectors 51 and 53 in turn are connected to wires 55 and 57, which terminate at electrical connections 59 and 61. Electrical connections 59 and 61 are releasably connected through connectors 81a and 83a to wires 81 and 83 disposed in each side of DEP 63. DEP 63 is housed in cavity 137 and secured to cavity 137 by coiled wire 143, which is in electrical connection with wires 81 and 83. Coiled wire 143 is able to elongate and retract, allowing DEP 63 to be removed from cavity 137. It is contemplated that the ear bud system 41 of the invention—comprised of two separate ear buds—could be used with a plurality of electronic devices of the invention. Ear bud assemblies 43 and 45 are not electrically connected to signal source and therefore cannot provide stereo sound without being connected to another electrical part. This is typically provided by the wearable electronic articles of present invention. Electronic devices of the prior art include only one jack for connecting one electrical plug for one ear bud assembly. Contrary to the prior art, and in order to create biologically fit wearable devices, the present invention teaches a method and device that uses two separate ear bud assemblies, and the wearable electronic articles of the invention preferably have two plugs for ear buds instead of one as provided by the prior art. It is

22

also understood that a kit for stereo sound comprising a box housing two ear bud assemblies is within the scope of the invention.

FIG. 1J shows another specialized ear bud system 41 for stereo sound coupled to detachable electronic package. 63. Ear bud system 41 includes separate ear buds 43 and 45, which are attached to wires 101 and 107. Preferably, wires 101 and 107 are very short. Ear buds 43 and 45 have plugs 85 and 87 which are releasably connected to electrical connectors 51 and 53 of wearable article 115. Connectors 51 and 53 have wires 55 and 57, which terminate into a single electrical plug 89. Electrical plug 89 is releasably connected to electrical connection 91 of DEP 63. Wearable article 115 (which could be, for example, a headband, helmet, garment or a hat) includes pocket 119 for retaining DEP 63. Pocket 119 has slot 123 and coiled wire 125 secured to one of the walls of pocket 119. Wire 125 terminates at plate 127, which is housed inside the pocket 119. Plate 127 is releasably connected, preferably with a hook and loop fastener system, to fastener 135 (which is also preferably a hook and loop fastener) of DEP 63. The preferred length of wires 101 and 105 is equal to or less than 15 cm, more preferably equal to or less than 12 cm in length, and most preferably equal to or less than 9 cm in length. Such system can be used in an electronic wearable cap in a similar manner as illustrated in FIG. 37, which shows another preferred embodiment. It is understood that a spring loaded spool with retractable wire can be replaced by a coiled wire with retracting capabilities without spring loaded mechanism. It is further understood that when a storage area is used, such as pocket, the wire can be straight and without retracting capabilities, with the wire remaining in a rolled up or folded position when stored and straight when use for placement on the ears. Alternatively, connector 91 may be connected with wire 125, and then the Velcro strip may use electrical pads for electrically connecting to electronic device, or plug 89 may use a coiled wire, so when coiled wire 125, which is used for support, extends, then coiled wire of plug 89 extends as well, maintaining thus electrical connection with ear buds during extension. One coiled wire is for electrical connection, and the other coiled wire is for support.

FIG. 2A shows wearable electronics provided by the Prior Art when worn by a user. The weight distribution of the prior art will activate pain fibers in the neck, causing discomfort and limiting the utility of the devices. A relatively heavy electronic device such as computer or other electronic device 80 will elicit discomfort and prevent comfortable wear when the electronics, display, and other parts collectively gathered in box 82 are supported by collar 84 that encircles the neck. Even if there is an opening 84a in collar 84, the prior art systems need to close that opening circle in order to be operational and was designed to be supported by the user's neck. This is because any time the two ends of a wrap-around system connect, for example forming a circle such as in collars around the neck, belts around the waist, or straps across the chest, and the like described in the prior art, there is a change in the vector force and more pressure is applied to a localized anatomic area, which can more readily activate pain fibers and elicit discomfort. The prior art, in order to keep the whole electronic system in one location, imposed significant pressure in one localized anatomic area. Therefore, pain receptors are activated based on the amount of pressure within this localized anatomic area, leading to discomfort when those devices of the prior art are used. While there is an apparent advantage, as provided by the prior art, in keeping the weight of the device in a localized anatomic area and covering a smaller surface area of contact

with the body, this apparent advantage works against the biology of the body and inhibits comfortable use. Thus, the present invention further contemplates a wearable electronic device which distributes weight to different anatomic regions, increasing user comfort as compared to the prior art.

Vector F in FIG. 2A represents the large amount of weight that is placed against the neck, and the total of the weight of the right and left side of the collar is represented by vectors F1 and F2. The resulting total weight of both sides represented by vector F creates pressure in the sensitive neck area. Furthermore, by not creating proper weight distribution of the device on the user, which is very difficult when it is supported by a collar around the neck, there will be acceleration and motion of the device, which can create friction on the user and increases the user's skin and increases the user's discomfort in the neck area.

In order to provide a useful, practical, and comfortable wearable electronic device, a series of key criteria should be met, as is accomplished by present invention. First, it is important that the weight of the device be shifted to areas that are less sensitive to pain and discomfort. In accordance to one embodiment of the invention, weight is shifted for instance to the nose and to the shoulder, or to the back of the head, for example when using a hat.

Second, in order to be more easily used, the system needs to function like a conventional computer and include all parts of a conventional computer. In one embodiment of the present invention, the wearable electronic device includes all the components of a conventional computer including heavier and large items such as a keyboard. It also provides a keyboard that can be typed on with two hands and a display (or monitor) that provides large visual angles.

Third, to achieve proper weight distribution, the electronic parts should be disposed using two arms, spaced apart from each other. Fourth, the arms need to have a combination of flexible and extendable portions for conforming to the anatomy of the body and to position of the parts when in use, and to allow a compact spatial conformation when not in use. This makes wearing and use of the wearable electronic device more practical.

Fifth, to achieve stability and good weight distribution, the supporting structure may comprise a cord, which runs continuously from one end of the device to the other, and which holds the electronic components at the end of each arm, and may operate as a pulley. Sixth, the masses of each side of the device should be similar. In accordance with one embodiment of the invention, this is achieved by disposing a keyboard one side and a display unit at the opposite side, the display unit and keyboard being of similar dimension and weight. Seventh, the wearable electronic needs to be stable while in use, for example while the user is typing. This may be accomplished by having a counter weight effect arising from a connection between the display unit and a power source.

Eighth, the weight of the wearable electronic device should not be placed in only one anatomic area in order to avoid localized pressure, which can more easily activate pain fibers. Thus, the weight of the wearable electronic device should be spread to different anatomic areas. For example, one embodiment of the present invention provides a wearable electronic device in which the weight is spread to four different anatomic areas: neck, shoulder, chest, and waist.

Ninth, the greatest part of the mass of the wearable electronic device (ordinarily represented by the electronics) should be disposed at the ends of an independent tube-like structure that rests directly against the body. This achieves a

better balance between the two sides and conformability to the body. Tenth, in order to increase the utility of the unit, the wearable electronic should have the capability to be used when not worn on the body. Eleventh, the wearable electronic article will preferably not encircle, rest against, or put pressure on the neck area, ear area, and other sensitive areas of the body.

These principals are incorporated into the embodiment shown in FIG. 2B, which shows a diagrammatic representation of a preferred embodiment of the wearable electronic computer of the invention. FIG. 2B shows the weight distribution of a preferred embodiment of the present invention including inverted U-shape support structure 88 with arms 90 and 92. In another embodiment, the support structure can have an inverted V-shape. Arm 90 has keyboard 94 disposed at its end. Arm 92 has a display 96 disposed at its end. Therefore, support structure 88 covers three distinct anatomic areas: neck 93, shoulders 95, and chest 97. The weight is further distributed to a fourth anatomic area, by securing box 96—housing a power source and electronics—to the user's waist. Box 96 is connected to support structure 88 by cable 98. By having arms 90 and 92 spaced apart, there is less pressure on any one particular anatomic area, inhibiting the activation of pain receptors.

The inverted U-shaped support structure distributes the devices weight to multiple anatomic areas. It does this, from the physical stand point, as a cord connecting two masses (m1 and m2) exemplified in the invention by display 97 (m1) and a keyboard 94 (m2), with cord 93 running over a “pulley,” represented by the user's neck and shoulder. The forces in play are the downward force of gravity and the upward force due to the tension in the cord. Masses m1 and m2 should be similar to avoid acceleration, because acceleration would cause friction in the user's skin and activation of pain fibers. Therefore, the parts of the electronic device are disposed in a manner that the mass in one side of the cord is similar to the mass in the opposite side of cord 93. This creates equal or roughly equal tension in each side of cord 93. Vector G represents the distributed force in the right arm, which is divided into three components: vector G1 for the neck, vector G2 for the shoulder, and vector G3 for the chest. The same applies to vector H on the opposite side, represented by vectors H1 (neck), H2 (shoulder), and H3 (chest). Vector GH represents the pressure in the user's neck, and is much smaller than vector F of the prior art as shown in FIG. 2A. Vectors J1 and J2 represent the tension in cord 93 and vectors G and H are preferably approximately or precisely equal. Therefore no acceleration or friction is generated, allowing for comfortable use. Other benefits and features will become apparent from the description and figures pertaining to the related embodiments described in other portions of this specification. Although two arms are described, it is understood that three or more arms can also be used and provide good weight distribution and proper design, as in accordance to the teachings of the invention.

The pain threshold in the neck is generally in the range of 40 to 70 g/mm²; in the shoulder and adjacent areas, the pain threshold is generally in the range of 60 to 100 g/mm². Pain receptors are typically not activated until the pressure reaches those limits, and therefore the weight of the wearable electronics of the invention takes this into account to provide comfortable wear. In addition to its weight distribution, the absolute maximum weight supported by the anatomic area is important to prevent activation of pain fibers. Based on the pressure and pain threshold in the neck, shoulder, and chest, the present invention provides proper weight, weight distribution, and design of the structure of

25

the wearable device to allow comfort and long term use of the wearable electronic device,

By way of illustration, but not of limitation, an illustrative preferred embodiment will be described: This embodiment of the wearable electronic system of the invention comprises an inverted U-shaped support structure measuring (without including keyboard and display) preferably equal to or less than 70 cm in length in its non-extended configuration, and more preferably equal to or less than 60 cm, and most preferably equal to or less than 50 cm, and even more preferably equal to or less than 35 cm. The dimension of the inverted U-shape depends on the size of the user. The biologically fit wearable computer combines an extendable portion, preferably using a spinal configuration, and a flexible gooseneck portion. The support structure has a surface area in contact with the user of approximately 1 cm² per centimeter of length. This provides for approximately 600 cm² of the support structure in contact with the user, equally divided among neck, shoulder and chest. The device provides for a preferred maximum weight of 700 grams on each arm of the support structure (1400 g total), which can be supported in the neck and shoulder/chest area in a comfortable manner without activating pain fibers. Although each arm can support 850 grams, preferably, the maximum weight for comfortable wear on each arm of the support structure is equal to or less than 650 grams, and most preferably equal to or less than 500 grams, minimizing activation of pain fibers in the user.

Although the invention can function solely with all of the components supported on the inverted-U support structure, in order to optimize weight distribution, the invention can also spread the weight to areas in the body that are biomechanically fit to hold a larger amount of weight, such as the waist area. Accordingly, the support structure can be connected by a connecting cord to a housing supported on the user's waist. Heavier parts such as a power source, mother board, hard drive, DVD player/writer, and other computer parts are preferably displaced to the waist area, and held in place preferably by a belt clip or other fastening means to the waist area of the body.

FIG. 3 illustrates another biologically fit and optimally distributed weight wearable electronic article of the invention, represented by eyeglasses. Accordingly, FIG. 3 shows detachable electronic eyeglasses 129 including right lens rim 120 and right temple 114 and left lens rim 118 and left temple 116 with extended right ear bud cord 126 and left ear bud cord 128. Right temple 114 includes portion 134 which houses cord 126, portion 130 which houses right ear bud 122, portion 141 which is connection between portion 134 and 130, wire 140 and electrical plug 148 at the end portion 144. Left temple 116 includes portion 136 which houses cord 128, portion 132 which houses left ear bud 124, portion 133 which is connection between portion 136 and 132, wire 138 and electrical plug 146 at the end portion 146. Cord 128 inside portion 132 is preferably secured to a rotating cylinder 131 for frictionless winding of cord 128. FIG. 3 shows cord 128 and 126 in a tension-free manner and extended for use and placement on the ear of the wearer. Cords 128 and 126 extend and retract upon actuation working as a retractable ear bud cord spool. The invention allows easy and repeated pulling and retracting of the ear buds 122, 124. A release button (not shown) to allow cords 126 and 128 to retract automatically back into house 134 and 136 can also be used.

FIG. 4 shows detachable electronic eyeglasses 139 including right temple 176 and left temple 174 with right ear bud cord 154 and right ear bud 150 retracted inside temple

26

176 and left ear bud 152 and left ear bud cord 156 retracted inside temple 174. Right ear bud 150 is connected to coiled up cord 154 through wire portion 160 and to electrical connector 172 through wire 164 housed in the end portion 168 of temple 176. Left ear bud 152 is connected to coiled up cord 156 through wire portion 158 and to electrical connector 170 through wire 162 housed in the end portion 166 of temple 174.

FIG. 5A to 5D shows different embodiments of the temple of the eyeglasses in accordance to the invention. It is noted that temples 233, 234 in FIG. 5A are substantially identical to each other such that description of features of one temple herein applies to the other temple as well. FIG. 5A shows the detachable electronic eyeglasses 230 including specialized right ear bud 241 and left ear bud 240 wherein such ear buds 240, 241 are an extension of temple 233 and 234. This embodiment allows the right ear bud 241 and left ear bud 240 to be completely hidden behind the ear of the wearer.

FIG. 5A shows detachable electronic eyeglasses 230 having a right temple 233 and a left temple 232. Left temple 232 comprises coiled wire 234 which extends along the side of temple 232. Coiled wire 234 includes two wires 236 and 238, with wire 238 connected to electrical connector 242 and wire 236 connected to ear bud 240, thus creating an electrical circuit from ear bud 240 to electrical connector 242, with said electrical connector 242 releasably connected with electrical connector of DEP (not shown). FIG. 5B shows the end portion 252 of right temple 250 and includes portion 254 at the end of temple 250, with said portion 254 housing coiled wire 256 which is connected to ear bud assembly 260, and portion 261 at the free end 259, which houses electrical connector 258. By way of illustration, it is shown a clip 262 at the free end 259, which secures ear bud assembly 260 to said free end 259 of end portion 252 of temple 250. It is understood that although a clip is provided as means to secure the ear bud 260 to the free end 259 of the frame, any fastening or adhesive means can be used to secure and/hold ear bud assembly 260 to free end 259.

It is noted that temples 264, 265 in FIG. 5C are substantially identical to each other such that description of features of one temple herein applies to the other temple as well. Accordingly, in FIG. 5C there is seen detachable electronic eyeglasses 270 having a right temple 265 and a left temple 264. In this embodiment, all the retractable wiring 266, wire 274, wire 276 and electrical connector 268 are housed at the free end 275 of the temple 264. End portion 275 houses spool-based retractable wire 266 with said wire 266 having two ends 274, 276, wherein wire end 274 is connected to ear bud 272 and wire end 276 is connected to electrical connector 268. Electrical connector 268 can function as an electrical pad and adapted to make electrical contact with electrical connectors of a DEP (not shown). FIG. 5D shows a magnified view of end portion 276 with its free end 280 having a portion 277 for housing wires and electrical connectors (not shown), and clip 275 which holds wire 279 in place, with said wire 279 connected to ear bud 278. In these embodiments the thickness of temples 264 and 265 are no longer limited by the size of the ear bud. Accordingly, temples 264 and 265 can be made very thin.

In FIG. 5E there is seen another embodiment of the specialized eyeglasses of the invention with wireless transmission of signals comprised of wireless detachable electronic eyeglasses system 289 including connecting cable 263 and wireless electronic eyeglasses 251 having right temple 257 and left temple 255 and right ear bud 273 and left ear bud 272. Wireless eyeglasses 251 is in wireless communication with electronic package 245 such as a digital music

player, cellular, phone, and the like. Connecting cable 263 has right electrical connector 285 and left electrical connector 287 with said right connector 285 and left connector 287 being releasably connected with right female electrical connector 267 and left female electrical connector 268 of wireless electronic eyeglasses 251. Within temple 255 is disposed a wireless transceiver 253 for transmitting and receiving wireless signals, power source 247, retractable wiring 266, wire 269, wire 274, wire 276, and electrical connector 268. End portion 243 of temple 255 houses spool-based retractable wire 266 with said wire 266 having two ends 274, 276, wherein wire end 274 is connected to ear bud 272 and wire end 276 is connected to electrical connector 268. Right temple 257 includes ear bud 273 which is electrically connected to electrical connector 267 in temple 257 through wire 249. Transceiver 253 is disposed within temple 255, preferably at the end portion, however it is understood that transceiver 253 can be disposed on or within any portion of temple 255. Transceiver 253 is electrically connected with spool-based retractable wire 266 through wire 269, for delivering a wireless signal received by transceiver 253 to ear buds 272 through wire 274 and to ear bud 273 through connecting cable 263, whereupon the present invention can deliver sound to both ear buds 272, 273 and allow therefore experiencing stereo sound. It is also understood that a power source can be disposed within temple 257 to increase battery time. Connecting cable 263 can be replaced by a wire going from left temple to right temple, but such embodiment has drawbacks and limitations since the wire has to go through the hinge mechanism of the eyeglasses.

FIG. 6 shows the detachable electronic eyeglasses system 290 of the invention comprising DEP 281 and detachable electronic eyeglasses 283, which are connected to each other through electrical connections 286 and 288. DEP comprises right and left cords 282, 284 and electronic package 292. Detachable electronic eyeglasses 283 comprises temples 301 and 303, with said temples 303, 303 housing coiled retractable wires 296 and 298 with right and left ends 308 and 306 connected to right and left ear buds 292 and 294 at right and left free end 302 and 304 while right and left wire end 295 and 293 are connected to right and left electrical connection 286 and 288.

FIG. 6A to 6D shows exemplary embodiments for securing ear buds to the free end of the temples. Accordingly, FIG. 6A shows free end 300 having a hook 316 holding ear bud rod 314 and its associated ear piece 312 and wire 318. FIG. 6B shows pin/ear bud assembly 310 comprising pin 324 and ear bud 322. FIG. 6C shows pin assembly 310 comprised of ear bud 322 and pin 324 releasably connected to free end 326. FIG. 6D shows an exemplary free end assembly 320 comprising ear bud 332 attached directly to free end 334, with wire 336 of DEP running adjacent to ear bud 332 and connected to free end 334 through a metallic plate 328 working as electrical connector. FIG. 6E shows an exemplary DEP 330, which comprises two wire portions 346, 348 with electrical connectors 344, 342, and electronic package 352, with said package 352 including standard play/pause/stop buttons 360, ports 358, 356, search button 354, and speaker 350.

FIG. 6F shows a side view of the detachable electronic eyeglasses 291 when worn by user 361 and that includes wire 313 connected to ear bud 315 and female electrical connector 317 disposed in the mid portion 319 of temple 305 with said female electrical connector 317 being releasably and electrically connected with male electrical connector 307 of cord 309 of DEP 321. DEP 321 includes a micro-

phone 311 that may be disposed in the upper third portion of cord 309 with said cord 309 electrically connected to electronic package 292, such as a cellular phone or a wireless communication device, such as a BLUETOOTH device. Alternatively a microphone as well as a speaker (for emitting audible sound) may be installed and integrated directly into electronic package 292. The DEP may be secured to other articles by having a connecting structure, mechanically and/or electrically coupling the two free ends of the arms. DEP 321 can be permanently affixed to the cord 309, and in this embodiment there are no extendable cords and spool connected to the electronic package. At least one temple has an integrated speaker or ear bud assembly. The temple may also include a built-in microphone. Cord 309 has electrical connector 307 in its free end while the opposite end is connected to electronic package 292 that is positioned in the back of the neck of user 361. It is understood that a male electrical connector or plug can be used in the temple 305 while male electrical plug 307 of cord 309 is replaced by a female electrical connector.

During cellular telephone use the microphone disposed in the DEP captures sound and a wireless transmitter in the electronic package transmits sound to a remote location while a receiver in the electronic package receives an audio signal and transmits the sound to ear buds. Electronic package can also include a recorder that records the sound being received and transmitted. The invention allows therefore a user wearing a DEP cellular phone to interact with the electronic package using speech, a key biological function, and without increasing the weight or changing the appearance of the eyeglasses frame.

FIG. 7 shows the detachable electronic eyeglasses 394 when worn by user 361, and having ear buds 386, 388 and associated coiled wires 384, 382 placed on the ears 390, 392 of user 361. FIG. 7 also shows DEP 362 (which can include the DEP of FIG. 6F) comprised of electronic package 364, wires 366, 368, and electrical connectors 370, 372 releasably connected to electrical connectors 374, 386 of temples 380, 378 of detachable electronic eyeglasses 394 worn by user 361.

The electronic package 364, such as a digital music player or a cell phone, of the DEP 362 is electrically connected to right temple 378 and left temple 380 and with right ear buds 386 and left ear bud 388, allowing the hearing of the wearer to interact with and receive sound from the electronic package 364, and providing thus interaction with a key biological function, which is hearing despite the electronic package 364 not having capabilities to emit an audible signal and without changing the appearance of frame of the eyeglasses.

Referring to FIG. 8, the detachable electronic eyeglasses system 400 with robotic arms 408 is worn by user 401, and there is seen the DEP 402 with wires 396, 398 which create an electrical circuit with eyeglasses 412 through electrical connection 404, for connecting DEP 402 to temple 414 and transmitting sound from DEP 402 to ear bud 406 through wire housed in robotic arm 408.

FIG. 9 is a side view of the detachable electronic eyeglasses system 430 worn by user 440 that includes an electronic package 432 that has a portion 437 that allows self adjusting the length of cord 434 to achieve a snug fit. Cord 434 has an extra portion 435 that allows adjusting to different sizes of head and comfort level. FIG. 9 also shows left lens rim 448 and left temple 446 including wire 444 and ear bud 442 extended and positioned on ear 441, with end portion 438 of temple 446 electrically connected to cord 434 of DEP 435 through electrical connection 436 for connecting

with electronic package 432. Although a flexible and coiled wire is shown as wire 444, it is understood that a variety of stiff wires and visible wires comprised of an arm that connects the ear bud to the frames of the eyeglasses can be used.

FIG. 10 shows an alternative embodiment in which the ear buds and spool with retractable wire are housed in the same plane of the temple as one unit. Accordingly, FIG. 10 shows the detachable electronic eyeglasses 450 worn by user 466, in which the right temple 458 and left temple 456 have only one area for housing both the ear bud and the retractable cord and spool, which correspond to right area 462 and left area 460. Right and left area 462, 460 houses an ear bud assembly (not shown), in which the retractable cord rests against the ear bud. Right and left temple 462, 460 are connected to right and left lens rim 454, 452 and have right and left electrical connections 466, 464. End portions 464, 466 are supported by right and left ear 470, 468. FIG. 10A shows another embodiment in which end portion 476 of temple 468 has electrical connector 474 and houses the retractable cord in area 470 and the ear bud 472 rests adjacent to area 470. FIG. 10B shows a side view of FIG. 10A showing end portion 484 of temple 468 having electrical connector 482, spool with retractable cord 478 and ear bud 480, which is partially covered by temple 484.

FIG. 11 is yet another embodiment showing detachable electronic eyeglasses 490 and an exemplary electrical connection 505. Eyeglasses 490 includes right and left temple 492, 494, right and left ear bud 496, 498 and right and left electrical connector 502, 500. Left temple 494 houses a small battery 495 and light source 497 for illumination, and in this embodiment the illuminating function can be performed independent of attachment to a DEP. Electrical connector 502 of right temple 492 is releasably electrically connected with electrical connector 505 which includes electrical prongs 504 and wire 506. In this embodiment ear buds 496 and 498 are not hidden within the frame, but the dimensions of said ear buds 496, 498 are preferably confined to the dimensions of the temples 492, 494. FIG. 11A shows in more detail an exemplarily electrical connection between temple 512 and electrical connector 508, with said electrical connector 508 comprised of prong 510 and wire 506.

FIGS. 12 and 12A shows another preferred embodiment that includes longer wires of the DEP for connecting the detachable electronic eyeglasses of the invention with commercially available devices, such as digital music players as an iPod of Apple Computer. Accordingly, in FIG. 12 there is seen, a detachable electronic eyeglasses system 580 comprised of DEP 611 and detachable electronic eyeglasses 582. DEP 611 includes right wire 608 and left wire 610 connected to digital music player 612 and including right and left electrical connectors 604, 606 releasably connected to electrical connectors 600, 602 of temples 584, 586. In this embodiment the individual length of right wire 608 is preferably more than 15 cm and less than 75 cm, and most preferably more than 2.5 cm in length and less than 65 cm in length. Same preferred length applies to left wire 610. It is understood that shorter wires can also be used, including a configuration that places the DEP 611 on the back of the head of the user. Detachable electronic eyeglasses 582 includes right and left temples 584, 586 housing right and left ear buds 588, 590 and right and left cords 592, 594, with right and left end portions 596, 598 housing right and left electrical connectors 600, 602.

FIG. 12A shows detachable electronic eyeglasses system 625 comprised of detachable electronic eyeglasses 620 and DEP 618 worn by user 614, with said DEP 618 including

electronic package 634 such as an iPod, which may be removably mounted on the DEP 618 with said electronic package 634 electrically connected by wire 632 with end portion 623 of temple 616 through electrical connector 628 at free end 630 with said electrical connection allowing transmission of sound to ear bud 624 by coiled wire 622 with said ear bud resting on ear 626 of user 614. In this embodiment, as seen in FIG. 12A, electrical connector 628 faces downward for better positioning of cord 632 across the neck and shoulder for holding an electronic package such as an iPod. In this embodiment the DEP may not include a retractable cord connected to the electronic package, since visual and tactile function are possible because the electronic package is within the visual field of the user.

It is understood that instead of a two part system comprised of detachable electronic eyeglasses and DEP 611, the invention also includes a three part system.

Accordingly FIG. 12B shows a three part system comprised of electronic package 601, cord 603, and detachable electronic eyeglasses 605, with said cord 603 having one electrical connection 607 for connecting with electronic package 601, and the opposite end is subdivided in right and left cords 609, 611, and right and left electrical connections 613, 615 for releasably connecting with right and left temples 617, 619. In this embodiment, right and left cords 609, 611 have electrical connections in both of their free ends, with said electrical connections 613, 615 in one end releasably connected with right and left temples 613, 615 of eyeglasses 605 and the opposite end having an electrical connector 607 for releasably connecting to an electronic package 601 such as a digital music player.

FIG. 13 shows a front view of user 641 wearing detachable electronic eyeglasses system 647 comprising DEP 657 and detachable electronic eyeglasses 636. Eyeglasses 636 have display 639 and antenna 646 for wireless communications with other electronic devices. Eyeglasses 636 is connected to DEP 657 through right and left wires 642 and 644 which are releasably and electrically connected with right and left cords 656 and 658 of DEP 657. Detachable electronic eyeglasses 636 further includes right and left temple 643 and 645, and right and left lens rim 637 and 638. Right lens rim 637 has display 639 for projecting still images, video images, a computer screen, and the like. Display 639 is connected by wire 640 (located within lens rim 637) to wire 642 in temple 643. Wire 642 is electrically connected with electronic package 655 of DEP 657 and can receive images and audio signal from DEP 657. Audio signals are transmitted to right and left ear buds 652 and 654 by right and left coiled wires 648 and 650. Imaging signals are transmitted to display 639 through wire 642 and wire 640. Left temple 645 includes antenna 646 for receiving wireless signals and wire 644. Wire 644 is electrically connected with DEP 657 through cord 658. A flexible display that can roll up in front of the lens can also be used. For instance, when a wireless signal is received by the DEP or by the frames, a signal can be sent to unroll the screen to see the message. The display portion can also include anchoring means and be removably mounted in the frame, and in this embodiment wire 640 may include a connector for connecting with the display.

DEP 655 can also include a wireless receiver for receiving audio and imaging signals. In this embodiment, the user can, for example, receive a wireless television signal or video signal and watch it using the eyeglasses or other head mounted gear of the invention. For example, DEP 655 can receive a signal from an airplane video system allowing the passenger to watch video and hear sound using the eye-

glasses 636 without the need for a separate screen. Likewise, DEP 655 can be wirelessly or wired connected with a computer, with display 639 of the eyeglasses replacing the screen of a computer, allowing thus privacy when working with a computer in a crowded environment, as may found on an airplane.

FIG. 14C shows electronic eyeglasses with ear buds hidden away within the temples. FIG. 14C shows eyeglasses 680 having temples 674 and 676, with end portions 678 and 682 with electrical connectors 686 and 684. Ear buds (not shown) are housed in temples 674 and 676. FIG. 14B shows temple 674 in more detail, in particular area 770 for housing ear bud 772. FIG. 14A shows ear bud 668 that is housed in area 664 of temple 662, with retractable wire 666 extended for exposing ear bud 668.

FIG. 14D shows an alternative embodiment for the electronic eyeglasses system of the invention. Eyeglass system 683 is worn by user 641 and comprises detachable electronic eyeglasses 681, ear bud assembly 697, and DEP 699. Detachable electronic eyeglasses 681 include electrical connectors 671 and 673. Preferably, electrical connector 671 is disposed in the mid portion of temple 679, and connector 673 is disposed at the end portion of temple 679. Electrical connector 671 is connected to electrical connector 673 through wire 675, which is disposed within or on temple 679. Electrical connector 673 is releasably connected to electrical connector 685 of ear bud assembly 697. Ear bud assembly 697 comprises electrical connector 685, arm 773, and ear bud 701. Electrical connector 673 is releasably connected to electrical connector 771 of DEP 669, to permit delivery of sound from DEP 699 to ear bud 701. In this embodiment, the ear bud assembly is releasably connected to the temples of the eyeglasses. Although only one side is shown, it is understood that both temples have the electrical connections and wires for delivering sound from a DEP to an ear bud. Arm 773 preferably includes mechanisms such as retractable wires, telescopic arms, flexible and foldable arms for adjusting length for positioning ear buds on ears of user of different size and height. This embodiment provides a low cost system in which the temples only have wires and electrical connectors, but no ear buds. Preferably the axis of the connector in the mid portion of the temple has its axis parallel to the temple, to allow the temple to have a more compact configuration.

FIG. 15A shows an example of a temple assembly according to the invention. Temple assembly 690 including handle 698 and rod 701, connected to wheel 700. Rod 701 is moveable within groove 692. Temple 690 includes electrical connector 694 and wire 696, which connects to ear bud 702 through wire portion 703. Upon actuation, as seen in FIG. 15B, handle 710, rod 711 and wheel 712 are move inwardly in groove 692 toward connector 705 of temple 704, extending wire portion 714, and exposing ear bud 702 for placement on ear 716.

FIG. 16A to 16C show another embodiment of detachable electronic eyeglasses according to the invention. Detachable electronic eyeglasses 720 comprise temple assembly 724 and lens rim 722. As shown in FIG. 16A, temple assembly 724 has articulated arm 730, shown in an extended position. Temple assembly 724 further comprises ear bud 732, which is located on articulated arm 730, area 725 for housing ear bud 732 when not in use, and wire 726 for connecting ear bud 732 to electrical connector 728. FIG. 16B shows articulated arm 730 being folded, with ear bud 732 moving toward area 725 of temple 724. FIG. 16C shows articulated arm 730 in a completely retracted position. Upon retracting, articulated arm 730 and ear bud 732 are housed within the limits

of the temple 724. Articulated arm 730 houses wires (not shown) which are connected to electrical plug 728 through wire portion 726. As outlined above, articulated arms may be referred to herein as either robotic arms or telescopic arms. It will be understood that detachable electronic eyeglasses 720 have a second temple (not shown) with a similar structure to the temple shown on the figures and described above.

FIG. 17A shows another embodiment of the invention. FIG. 17A shows eyeglasses 740 comprising temple assembly 742 and lens rim 743. Temple 742 includes rotating wheel 744, which is secured to temple 742, preferably between end portion 748 and mid portion 749. Wheel 744 is permanently or releasably attached to rod 751. Rod 751 houses wire 745 and has electrical plug 746, which is releasably connected to wire 750 and electronics package 760 of DEP 758. Wire 745 of wheel 744 is connected to cord 752 through wire portion 747 in temple 742 for delivering sound to ear bud 754 on ear 756.

FIG. 17B shows detachable electronic eyeglasses system 740 of FIG. 17A being worn by user 762. DEP 741 is positioned over the head of user 762, with electronics package 792 held on top of the head by right and left portions 788 and 790. Right and left portions 788 and 790 are preferably made of a rigid material for stability and easy positioning, such as acrylic or hard plastic. Right and left portions 788 and 790 are electrically connected with right and left electrical connector 772 and 774 in right and left rod portions 768 and 770 of right and left wheels 766 and 764 for transmitting sound and to right and left ear 784 and 786 through right and left cords 776 and 778, connected to right and left ear phones 780 and 782. Electronic package 792 can include at least one magnet for neural interaction and/or at least one laser light or other form of light source, which deliver light to the scalp for stimulating hair growth. In this embodiment the electronic package can be replaced by an electrical device with larger surface area for delivering light to a larger area of the scalp.

FIG. 18A shows a slip-on detachable wearable electronic system according to the invention which can be attached to the temples of a pair of eyeglasses. Slip-on system 800 includes right housing 794 for housing power source 796, wireless device 805, and volume button 801. Left housing 793 houses electronics 795, port 803, and play button 799. Any combination of electronic parts and battery can be used in the right housing and the left housing. Right clip 802 clips the right temple of the eyeglasses (not shown) and its main face 809 rests against the head of the user. Left dip 798 clips the left temple and its main face 807 rests against the head of the user. Face 807 and 809 can comprise a soft or rubberized material for enhancing comfort when touching the skin. Slip-on system 800 further includes wire 812 which extends along the head of the wearer and connects right housing 794 and left housing 793. Right and left housing 794 and 793 are connected to right and left ear buds 808 and 810 by right and left arms 804 and 806. Importantly, any combination of electronics and control buttons housed in can be used to deliver stereo audio signals to the ear buds.

The slip-on system can include a single slip-on structure or a dual slip-on structure, said dual structure being connected to each other by a wire. A single slip-on structure can function as a wireless communication device (e.g., BLUETOOTH device), said slip-on structure including a housing having a hook-like structure for engaging the temple of eyeglasses, and further including a microphone, transmitting/receiving module and circuit, antenna, digital-analog converter, and an ear bud assembly or a connector for an ear

bud assembly. In use the slip-on structure is engaged to the temple of the eyeglasses and the ear bud placed on the user's ear. The slip-on device may include a built-in speaker for placement directly on the user's ear and a structure or ear support, similar to the embodiment of FIG. 34D. Thus, the new BLUETOOTH device of this invention can use the ear bud and function as an eyeglass temple supported device or can use the built-in speaker and function as an eyeglass temple supported device or can use the built-in speaker and function as a conventional ear supported device. When stereo sound is desired, such as the slip-on device working as an MP3 music player, a dual slip-on is preferred for housing the electronics and for delivering stereo sound using two ear bud assemblies. The slip-on structure may include a retractable spool and a wire connected to the ear bud. Another BLUETOOTH embodiment of this invention includes an ear supported BLUETOOTH and a speaker emitting audible sound to the environment and a microphone having a microphone stalk (in addition to a built-in microphone), or having a connection for a microphone having a microphone stalk. This allows the device to be worn on the ear as well as in the storage cord and also secured to another device.

FIG. 18B shows a side view of slip-on system 800 for positioning on the temples of a pair of eyeglasses. Clip 802 slips-on the right temple of the eyeglasses (not shown) to secure housing 794 to the right temple. Right housing 794 contains power source 796, arm 804 and ear bud 808. Clip 798 slips-on the left temple of the eyeglasses to secure housing 793 to the left temple. Left housing 793 contains electronics 796, arm 806, and ear bud 810. Wire 812 connects right and left housing 793 and 794, and extends along the neck of the wearer. Wire 812 may be connected to a spring loaded spool housed in housing 794 or 793. Clips 798 and 802 are substantially of smaller dimension than housings 793 and 794. The preferred length for the arm of the clip 798 and 802 is equal to or less than 40 mm and preferably equal to or less than 30 mm, and most preferably equal to or less than 20 mm, and even more preferably equal to or less than 10 mm. Clips 798 and 802 are substantially thinner than housings 793 and 794 and are preferably equal to or less than 10 mm in thickness, and more preferably equal to or less than 5 mm in thickness, and even most preferably equal to or less than 2 mm in thickness.

FIGS. 19A to 1913 show another embodiment of a slip-on system according to the invention. FIG. 19A shows clip-on assembly 820 having an adjustable serrated system comprised of movable parts 814 and 816 which move relative to each other in order to adjust to the size of the temple (not shown) being held by clip assembly 820. Clip assembly 820 further includes area 822 for housing ear bud 818. Clip assembly 820 may include an area for an electronic package, and this embodiment may not include an electrical connector. Ear bud 818 is connected to retractable cord spool 826 or to a coiled wire. Retractable cord spool 826 has two wire endings: wire end 824 is connected with ear bud 818 and opposite wire end 828 is connected to electrical connector 829. FIG. 19B shows clip assembly 820 in use, secured to temple 832, with said temple 832 resting on ear 830.

FIG. 20 shows another embodiment of a slip-on system according to the invention. The system rests on temple 834 and has a spring loaded clip 836 comprising arms 835 and 837. Arm 837 is substantially thinner than arm 835. Arm 837 rests against the head of the wearer. Preferably, arm 837 is equal to or less than 10 mm in thickness, and more preferably equal to or less than 5 mm in thickness, and even more

preferably equal to or less than 3 mm in thickness and even most preferably equal to or less than 2 mm in thickness.

FIG. 21 shows an alternative embodiment of the spring loaded clip assembly with spring loaded clip 844 resting on temple 846 and having arms 853 and 849. Arm 853 rests against the head of the wearer and has an upper portion 851 and a lower portion 845. Upper portion 851 is substantially thinner than lower portion 845. Preferably, upper portion 851 measures equal to or less than 10 mm in thickness, and more preferably equal to or less than 5 mm in thickness, and even more preferably equal to or less than 3 mm in thickness, and even most preferably equal to or less than 2 mm in thickness. This configuration of a thin portion or arm, (such as portion 851) combined to a thicker portion (such as portion housing components) can be applicable to any slip-on or clip-on embodiments of this invention. Lower portion 845 of arm 853 has housing 850 which houses ear bud 848, coiled wire 852, and wire 854, which has electrical connector 856 in its free end.

FIG. 22A to 22C show another embodiment of the clip-on assembly of the present invention. FIG. 22A shows a compact clip-on assembly 860 having electronics 865 for playing digital music (or receiving a communication signal such as a cellular phone signal or a wireless device such as a BLUETOOTH device) in housing 861. Housing 861 also has retractable ear buds 862 and 863, preferably secured to the ends of housing 861. Housing 861 may include all components for a wireless device including music player, radio, video player, cellular telephone, and wireless communication device such as a BLUETOOTH device. Housing 861 may include structure and dimensions described for slip-on embodiments and may include structure and components described for embodiments of a wireless communication device, such as BLUETOOTH devices of this invention. Housing 861 may include only one ear bud such as when the electronic device housed in the housing 861 does not require stereo sound, as in wireless communication including using BLUETOOTH protocol. FIG. 22B is a side view of compact clip-on assembly 860 with clip 873 for attaching to the temple of eyeglasses. Compact clip-on assembly 860 has housing 861, cord 864 and ear bud 862. FIG. 22C shows compact clip-on assembly 860 releasably secured to left temple 868 of eyeglasses 868a being worn by user 870 and having retractable cords 864 and 866 extended for use. Compact clip-on assembly 860 includes housing 861 for housing electronics 865 power source 867, and port 869. Left cord 864 is connected to ear bud 862 and extended for positioning on the left ear 872. Right cord 866 is extended along the back of the head of the wearer 870 and is connected to a second ear bud (not shown) for placement on the right ear of wearer 870. In accordance to the invention, one cord connected to an ear bud is substantially longer than the opposite cord connected to the opposite ear bud. Accordingly, left cord 864 has preferably a length equal to or less than 15 cm, and right cord 866 has preferably a length equal to or less than 60 cm. More preferably, left cord 864 has a length equal to or less than 10 cm and right cord 866 a length equal to or less than 45 cm. In this embodiment all of the electronics and power source are located within housing 861. Preferably, the left and right cord when in use have dissimilar length. Preferably the length of the wire secure to the right spool is different than the length of the wire secured to the left spool, said length preferably being the length described above for left cord 864 and right 866. Furthermore, a coiled wire can be used and follow the same configuration for cord 864 and 866. It is understood that the clip can have left and right cords of similar length, or when

the clip for instance is held on a collar of a shirt, or on the back of the neck, or when the clip is secured to a string connected to temples of eyeglasses. It is understood that when working as a wireless device, such as a BLUETOOTH device, only one ear bud is necessary, and thus in this embodiment the eyewear clip has only one ear bud cord and one ear bud.

Embodiments described from FIG. 18A to 23C, such as slip-on and clips can include any electronic package, and more particularly may comprise a wireless communication device such as a BLUETOOTH device, a digital music player, a radio, a wireless telephone headset, and the like. The clip and slip-on embodiments can comprise a wireless device, such as BLUETOOTH device, and include a housing having at least one transmitter and receiver module, (such as a BLUETOOTH module) and the associated transmitting and receiving circuits, radio frequency circuit, a speaker (such as an ear bud) a microphone, a power source, and other common parts such as antenna, amplifiers, and function buttons for answering calls and volume control, and audio connector (such as a female connector).

FIG. 23 shows another embodiment of clip-on assembly according to the invention. Clip-on assembly 870 is releasably secured to temple 892 of eyeglasses 882 worn by user 880 ear 886. It has housing 876, arm 878, ear bud 884. Wire 872 connects with cord 874 for receiving an audio signal from MP3 player 888. End portion 873 of cord 874 is mechanically (not electrically) secured to end portion of temple 892. In this embodiment, temple 892 has no wires or electrical connectors, and wire 872 of clip-on assembly 870 runs on top of temple 892 and is electrically connected with cord 874.

FIG. 23A shows a top view of clip-on assembly 875, which has dual side clips 561 and 563. Assembly 875 has right and left housings 567 and 565, right and left robotic arms 575 and 573, right and left ear bud 569 and 571 connected to electronic package, such as a digital music player 581 via right and left cords 579 and 577.

FIG. 23B shows a clip-on assembly 871 with permanently extended arm 877 of ear bud 875. Clip-on assembly 871 is secured to eyeglass temple 879 by clip 873 and is connected to an electronic device (not shown) with wire 881.

FIG. 23C shows a three part sliding-on assembly 585 comprised of sliding-on ear buds, eyeglasses, and DEP. FIG. 23C shows sliding-on assembly 585 comprised of right sliding-on assembly 587 and left sliding-on assembly 589, each having electrical connecting plate 591, 593 for electrical connection with right and left temples 572, 570 and for adjusting the assemblies snugly to different sizes of temples. Sliding-on assemblies 587, 589 further includes right and left arms 578, 582 connected to right and left ear bud 576, 574. It is noted that temples 572, 570 are substantially identical to each other such that description of features of one temple herein applies to the other temple as well. Temple 572 has wire 595 for connecting sliding-on assembly 587 with electrical connection 568, with the electrical connection 568 being releasably connected with electrical connection 564 of DEP 556. DEP 556 includes right and left cords 558, 560 releasably connected with right electrical connector 568 of right temple 572 and left electrical connector 566 of left temple 570. In this embodiment, the temples only have wire and electrical connections but not ear buds, with said ear buds being housed in the sliding-on assemblies. Although the sliding-on assembly is shown as having an electrical connection with the wire of the DEP, it is understood that the wire of the DEP can be integral with the sliding-on assemblies. This embodiment can comprise

right and left sliding-on assemblies securing ear buds, a right and left wire connecting right and left sliding-on assemblies to a DEP, said DEP including a releasably attached electronic package, such as a music player.

In accordance to the preferred clip-on, slip-on, and sliding-on assemblies of the invention, very little weight is placed on the temples since the temples of eyeglasses holds a clip-on that only houses ear buds and light weight and small wires and plugs. The heavier part (electronics and power source) are housed in the DEP away from the temples and positioned behind the head. The assembly of the invention thus offers more comfort and better weight distribution. By having less weight on the temples less pressure is applied directly on the ear. Heavy temples of eyeglasses would be uncomfortable and over time could cause an injury to the thin skin around the ear. In addition since the larger and heavier part (DEP) is held away and at the end of the temple, the invention offers an additional benefit of helping stabilize the eyeglasses on the head and preventing frames from moving down on the nose.

FIGS. 24A and 24B shows exemplary embodiments of the temple assembly of the invention. In FIG. 24A there is seen thin temple assembly 890 with front portion 898 and end portion 894, with end portion 894 initiating at the bending point 911 of temple 890. Front portion 898 includes screw assembly 896 for connecting with lens rim (not shown), and end portion 894 having ear bud 904 connected with electrical connector 906 through wire 902. FIG. 24B shows thick temple assembly 900 with front portion 910 and end portion 918, and bending point 911. Front portion 910 having ear bud 912, wire 914, retractable coiled cord 916, and screw assembly 908 and end portion 918 having wire 920 and rotating electrical connector 922. Electrical connector 922 is disposed preferably at the end portion 918, and most preferably at the free end of end portion 918. Electrical connector 922 is secured to a wheel assembly 923 that allows electrical connector to be movable to any position, illustratively shown in two different positions in phantom lines.

FIG. 24C shows an exemplary latch mechanism assembly 924 for electrical connection of end portion 938 with plug 926. End portion 938 includes wire 940 and jack 932 with recess 936 for receiving plug 926 of DEP (not shown). Plug 926 includes wire 928 and latch piece 930 with protrusion 934 for releasably connecting plug 926 into jack 932. FIG. 24D shows temple assembly 925 with screw assembly 927 for connecting with lens rim in the front portion. End portion 933 includes ear bud 931 secured to free end 933 of temple 925 and adjacent to electrical connector 929.

As seen in FIG. 24D, electrical connector 929 is positioned not on the free end of temple 925, but on the side of the temple 925. Electrical connectors of temples may be located anywhere in the temple, but is preferably located at the end portion of the temple, and most preferably located on the side facing away from the head. As such any wire from a DEP connected with the temple will be facing away from the skin and not touching the skin, assuring even greater comfort for the user. Other preferable characteristics of the temple of the invention include a longer end portion of temple, which preferably ends at the lower part of the ear, and not in the mid-part of the ear as with conventional eyeglasses. As such, any wire or cord from DEP will be positioned away from the back of the ear, assuring greater comfort. In this regard, the end portion after the bend of the temple (represented by area 911) is the part of the temple adjacent to the ear, and said end portion of temple has preferably a length of more than 5.5 cm, and most preferably between 5.5 cm and 7 cm, and even most preferably between

5.5 cm and 8.5 cm. This length of the end portion is defined as the length from the free end to the portion of the temple that is bent (or in case of straight temples the portion right above the ears) represented by portion 911 of FIGS. 24A and 24 B.

FIG. 25A shows yet another detachable assembly in accordance to the invention. The assembly can function as a temple assembly or clip-on assembly. Assembly 944 includes lid 946 of housing 948, and housing 948, 958 for housing ear buds 952, 960, and area 956 for housing retractable cords 950 and 954. FIG. 25B shows clip-on assembly 944 secured to temple 964 by clip 967 and including areas 946, 958 for housing ear buds (not shown). In accordance to the invention, one cord connected to an ear bud is substantially longer than the opposite cord connected to the opposite ear bud. Accordingly, cord 950 has preferably a length of less than 15 cm while cord 954 has preferably a length of less than 60 cm. Most preferably, cord 950 has preferably a length of less than 10 cm while cord 954 has preferably a length of less than 45 cm.

FIG. 25C shows electronic eyeglasses 955 housing electronics in temple 957 as provided by the prior art, but having improved features provided by the present invention. In accordance to teachings of the present invention, temple 957 includes a cradle-like housing 72 defining cavity 74 which is sized to accept and retain in a releasable manner an electronics package 12 such as a digital music player, radio, cellular phone, and the like. Electronics package 12 is connected to a coiled cord 959 that is secured to cavity 74 and can be extended, in accordance to description of FIG. 1D and FIG. 1E.

FIG. 26A shows specialized, non-wired eyeglass temples to which the electronic clip-on assembly of the present invention may be readily attached. Temple 980 has end portion 992 and front portion 994 with screw area 996 for connecting with lens rim (not shown). Opening 990 within temple 980 is sized to receive arm 984 of slip-on assembly 982. Slip-on assembly 982 has a second arm 988 (shown with dotted lines) which houses ear bud 986.

FIG. 26B shows slip-on assembly 982 secured to temple 980 through opening 990. Preferably, arm 984 is substantially thinner than arm 988, which houses ear bud 986, retractable cord 998, and wire 987. FIG. 26C shows another embodiment of eyeglass temples adapted to receive a slip-on assembly according to the invention. Temple assembly 1000 includes screw area 1010, end portion 1012, and wall 1006 protruding beyond outside the edge of temple 1004. Wall 1006 defines opening 1002, and is adapted to receive a slip-on assembly according to the invention. It is understood that the temples and the free end of the temples may include a ring, a loop, a button, a sliding pin, a groove, and any other structure of FIGS. 183A to 183E, adapted for receiving complimentary anchoring means of the storage cord or DEP.

FIG. 27 shows a system according to the invention comprised of three parts, right temple 1049, left temple 1051, and DEP 1039. Right and left temple 1049, 1051 having screw area 1048, 1050 located in right and left front portion 1022, 1024, and further including right and left ear buds 1026, 1028, right and left wire 1030, 1032, and right and left female electrical connectors 1034, 1036 which are releasably connected with right and left connector 1038, 1040 for electrically connecting right and left temple 1049, 1051 with right and left wires 1030, 1032 and electronic package 1046 of DEP 1039.

FIG. 28 shows a kit of the invention comprised of DEP 1066, right temple 1049 and left temple 1051. Accordingly, there is seen in FIG. 28 kit having box 1060 which includes

area 1070 housing DEP 1066 and area 1068 housing right temple 1049 and left temple 1051, with said right and left temple 1049, 1051 having right and left ear bud 1063, 1061, right and left wire 1064, 1062 and right and left electrical connection 1059, 1057.

It is understood that one of the methods of the invention includes the step of replacing conventional temples of eyeglasses by the wired temples of the invention. This allows the user to keep the original lenses and lens rim of conventional eyeglasses, and just replace the temple with similarly looking temples as the original. With the temples of the invention the original eyeglasses with the original lenses and lens rims are now enabled to perform an electronic function.

FIG. 29 shows an exemplary DEP. It is understood that any article having the capability of performing a function including powering a light source, playing music, receiving a wireless signal, playing video, voice recording, video recording, receiving and/or transmitting an Internet signal, and the like is within the scope of the invention and can function as the electronic package of DEP with said article having electrical connections for releasably connecting with the frame of eyeglasses. The electronic package can be also releasably mounted on the storage cord. Although powering a light source is an electrical function, for the purposes of the description, any electrical function is described as a function performed by the Detachable Electronic Package or DEP. Furthermore, electronic package of DEP can include digital player for music and video, a small CD player, and a camera with SD card port for extra storage in the DEP. Function of DEP also include system for measuring biological parameter, and by way of illustration DEP can be adapted to measure glucose levels, temperature, eye pressure, blood pressure, oxygen, blood flow, or any other physical parameter or chemical substance present in the body. Again, by way of illustration, the electronic package of DEP is connected to a sensor secured to the eyeglasses in accordance to the sensing eyeglasses invented by Abreu and described in US Patent application 20040059212 and 20040242976, in which the wireless transmitter is removed from the front part of the eyeglasses and placed as a DEP in the back of the head, or alternatively the electronic package of DEP measures chemical substances such as glucose as a stand alone unit. An eyeglasses with tubes next to the nose to measure oxygen can have the electronics for processing the data and display housed away in the DEP, or alternatively the frame can include the electronics and display.

The apparatus and method of the invention allows a system that performs an electric or electronic function to be divided between DEP and the frame of eyeglasses, allowing therefore better weight distribution while allowing a wearable article such as eyeglasses to be capable of performing a second function besides visual function. Accordingly, DEP can include only a power source that powers a fan, heater, or Peltier device housed in the frame of the eyeglasses for heating and cooling the user. In this embodiment, the eyeglasses do not have an ear bud, with said eyeglasses having only a small fan or thermoelectric device for cooling purposes and an electrical connection for connecting with the DEP working as a power source for the fan. DEP can further function as a remote control, a wireless receiver for receiving a television signal, and a speaker. In addition, the invention allows hearing aids to be miniaturized since the power source and/or other electronics are located in the DEP and the small single hearing element is housed at the end of the temple of the eyeglasses. A variety of hearing aids and other devices can be made extremely small, in accordance to

the invention, by housing part of the device in the DEP, and part in the head mounted gear such as the frame of eyeglasses. Thus making the head mounted gear more comfortable and with multiple electronic functions. The ear buds of the eyeglasses can work as insulators from exterior noises while receiving sound from a digital music player, with part of the electronics and/or power source stored in the DEP away from the frames.

Although the preferred embodiment includes both right and left temples, having electrical connections and wires, it is understood that only one temple of the eyeglasses can have an electrical connection, with said electrical connection releasably connected to a wire from DEP. In this embodiment DEP is secure to both temples, but only one temple is electrically connected to the DEP while the other temple is only mechanically connected to the DEP.

In FIG. 29 there is seen DEP 1080 comprised of right and left cords 1090, 1092 housing right and left wires 1094, 1096 wires, with said wires 1094, 1096 connected in one end to right and left electrical connectors 1098, 1100 and at the opposite end said wires 1094, 1096 are connected to electronic package 1082, with said package having, by way of illustration a power source 1088, chip 1086, and memory 1084.

FIG. 30 shows kit 1110 comprised of detachable electronic eyeglasses 1112 and DEP 1122. Kit 1110 includes detachable electronic eyeglasses 1112 having right and left ear buds 1114, 1116 and right and left electrical connections 1118, 1120. DEP 1122 is comprised of two wires 1124, 1126 and two electrical connections 1128, 1130 at the end of said wires 1124, 1126.

FIG. 30A shows kit 1111 comprised of detachable electronic cap 1113 and DEP 1122. Kit 1111 includes detachable electronic cap 1113 having pouch 1117 on the side for retaining an ear bud and pouch 1115 on the back for retaining a DEP 1122 in accordance to the invention. DEP 1122 is comprised of two wires 1124, 1126 and two electrical connections 1128, 1130 at the end of said wires 1124, 1126.

FIG. 31A shows temple assembly 1140 having end portion 1142 connected to cord 1144 of DEP, with said cord 1144 connected to ear bud 1148. In this embodiment ear bud 1148 is connected to cord 1144 through wire 1146, with said ear bud 1148 housed outside temple 1142. FIG. 31B shows temple assembly 1150 with the electrical connection between plate 1152 at the end of cord 1158 of DEP and temple 1154. Plate 1152 is electrically connected with electric connection 1156 of temple 1154, with end portion 1160 of temple 1154 being free of any electrical connectors or wires.

FIG. 32 shows a preferred embodiment of detachable electronic eyeglasses 1170 with right and left ear buds 1178 and 1176 hidden away within the structure of right and left temples 1182, 1180. Right temple 1182 includes portion 1174 for housing ear bud 1178 and end portion 1192 with electrical connection 1188 for connecting with cord 1189 of DEP. Left temple 1180 includes portion 1172 for housing ear bud 1176 and wire 1196 connected to camera 1184 adjacent to left lens rim 1186. Left temple 1180 further includes wire 1198 in the end portion 1194 connected to electrical connection 1190 and cord 1191 of DEP. FIG. 32A shows another embodiment in which ear bud 1178 is secure to the outside wall 1180 of temple 1181, with said ear bud connected with electrical connection 1190 at end portion 1194 of temple 1181.

FIG. 33 shows another preferred embodiment with ear buds secured to the end of temple and working as an

extension of temples. Accordingly, in FIG. 33 there is seen detachable electronic eyeglasses 1200 with right and left lens rims 1202, 1204, right and left temples 1206, 1208 with right and left end portion 1210, 1212 having right and left wires 1213, 1215 (shown as broken lines) connected to right and left ear buds 1214, 1216. Right end portion 1210 and ear bud 1214 are shown bent to reveal electrical connector 1230 adjacent to ear bud 1214 and wire 1213. Electrical connector 1230 is adapted to connect to a wire of a DEP (not shown). To be operational the detachable electronic eyeglasses need to be electrically or wirelessly connected to an electrical circuit housed in the electronic package, as described for other embodiments of the invention.

FIG. 33A shows a storage cord according to the invention attached to a pair of electronically enabled glasses according to the invention. FIG. 33A shows the eyeglasses 1240 when connected to DEP 1250 and worn by user 1241, with said DEP 1250 having electronic package 1242, right cord 1243, and left cord 1244. Left cord 1244 is electrically connected to temple 1246 through electrical connection 1248. Ear bud 1252 which was secured to the end of the temple 1246 has its wire 1254 extended with said ear bud 1252 positioned on ear 1253 of user 1241.

FIG. 34 shows another embodiment of a detachable electronic cord package according to the invention. In this embodiment, sleeves 1286 and 1284 at the end of cords 1266 and 1264 are preferably stretchable and have no electrical parts or connectors, and are used to mechanically secure the end of cords 1266 and 1264 to temples of eyeglasses (not shown). Detachable electronic cord package 1260 comprises electronics package 1262, and right and left cords 1264 and 1266. Electronics package 1262 can perform any of the electronic functions described in this application and described for DEP. Right and left cords 1264 and 1266 house right and left wires 1268 and 1270, right and left retractable cord spools 1272 and 1274, and right and left wires 1276 and 1278, which are connected to right and left ear buds 1280 and 1282. Retractable cord spools 1272 and 1274 can be replaced by an extendable coiled wire, or other means of retracting the wires. Right and left cords 1264 and 1266 further include right and left sleeves 1284 and 1286 or other means for securing cords 1264 and 1266 to the ends of eyeglass temples (not shown). Sleeves 1284 and 1286 are adapted for overlapping the free end of such temples. It should be understood that cords 1264 and 1266 can be secured to any portion of the frame of eyeglasses, such as for example the mid-portion of the temples by means, for example, of a clip-on, hook, slip-on, and the like located at the end of cords 1264 and 1266. The embodiment shown in FIG. 34 can attach to any regular pair of eyeglasses. Thus, with this embodiment, ordinary eyeglasses without wires or electrical connections can be fit with detachable electronic cord package 1260 of the invention. The sleeves are preferably made of a stretchable material such as, for example neoprene, cotton, leather, and the like, in order to more firmly secure the cord to the temple of eyeglasses. It is understood that electronics package 1262 can be removably secured to cords 1264 and 1266, or be permanently affixed thereto. If the electronic package 1262 is permanently affixed, a further third piece—preferably an essentially C-shape tube—may be used to connect sleeves 1284 and 1286. This makes the entire system into a round item which can be worn as a collar around a body part such as the neck. This embodiment thus allow the electronic package to be within the visual axis of the user, and even if the electronics package is permanently attached the device still would be easily reachable. Alternatively, electronics package 1262

can be housed in a cradle-like housing and have extendable/retractable cords, such as coiled cords or retractable spool cords, in accordance to other embodiments of the present invention described herein.

FIG. 34A shows detachable electronic cord package 1260 being worn by user 1290. Cord package 1260 is connected mechanically—not electronically—to regular eyeglasses 1292. Electronic package 1262 is positioned along the neck of user 1290, with left sleeve 1286 encasing free end 1294 of temple 1296. Preferably, sleeve 1286 has elastic properties to better secure said sleeve 1286 to temple 1296. Retractable wire 1278 exits from left cord 1268, and is shown in an extended position, connected to ear bud 1282, which is positioned on ear 1298. A variety of fastening means can be used to secure detachable electronic cord package 1260 to the frame of the eyeglasses including clips, groove mechanism, hook and loop fastener, snap-on, tying a knot to end portion of temples forming a ring (which may include the free end of the temple comprised of a ring configuration for tying a string of the storage cord 1260 or for receiving a complimentary hook from the storage cord 1260), sliding mechanism anchoring to a complimentary groove in the temple, and the like.

The detachable electronic system of FIG. 34B comprises connecting pouch 1261, DEP 1262, which is mechanically secured by connecting pouch 1261, eyeglasses 1277, and cable 1279. Connecting pouch 1261 comprises pouch 1263 with slots 1271 and 1273, and arm 1265. Arm 1265 terminates as stretchable sleeve 1267 for which can be snugly secured to temple 1269. Electronics package 1262 may be inserted into pouch 1263 through slot 1271. Electrical plug 1275 may be inserted into pouch 1263 through slot 1273. Cable 1279 preferably includes male plugs 1275 and 1283 and spool 1309. Plug 1275 is releasably connected to female connector 1285 of DEP 1262 and plug 1283 is releasably connected to female connector 1287 of eyeglasses 1277. Temple 1289 has an electrical connector 1287, while both temples 1289 and 1269 have ear buds 1293 and 1295, wires 1317 and 1319, spools 1301 and 1303, and housings 1297 and 1299 for the ear buds and spools. Wire portion 1313 is connected to spool 1301 and terminates in electrical connector 1287. Wire portion 1305 is connected to spool 1303, and goes from left temple 1289 to right temple 1291 through two metallic electrical plate assemblies 1307 and 1311 at the hinges to create an electrical contact between the lens rim and the temples. This avoids running a wire going through a hinge, and the consequent stresses of constant bending and unbending. Wire portion 1305 terminates in electrical connector 1287. It will be understood that cable 1279 can be covered by a cord that is permanently affixed to pouch 1263.

The present invention also provides an entirely new approach for Bluetooth-type headset devices. (By “Bluetooth device” or “Bluetooth-type device” I mean devices which attach to the user’s ear and communicate wirelessly with other electronic devices using Bluetooth communication protocols or other communications protocols.) Prior art wrap-around ear Bluetooth devices have the wrap-around arm on the Bluetooth device which competes for the same space on the ear as the end of the eyeglass temples. Thus people who wear eyeglasses have two hard items around the ear, making this practice uncomfortable, sometimes painful, and often ineffective with respect to securing the Bluetooth device to the ear. This embodiment of the present invention offers key advantages for people who wear eyeglasses on a regular basis and want to use a Bluetooth device. With the invention, the temple of the eyeglasses are the only piece which needs to rest on the ear, while the Bluetooth device or

other wireless device provides additional benefits to the user without requiring added hardware pressing against the head and ear. The Bluetooth device of the present invention shifts weight away from a very sensitive part of the body, the ears, and not even require any part of the device to press against the delicate and thin skin around the ears.

FIG. 34C shows prior art Bluetooth device 1461. Bluetooth device 1461 comprises ear support piece 1467, microphone 1465, and speaker 1463 (or any other device for transmitting sound. Speaker 1463 receives audio signal from a second device, such as a cell phone. Speaker 1463 is physically integrated into device 1461 and adapted to fit in the ear canal. Such devices are sold, for example by the Nokia Company of Finland and Motorola. Inc. of the United States. None of the known Bluetooth devices have a separate electrical connector for an ear bud, since they were designed to be held by the ear, and were able to generate sound without any external wires.

The present invention provides an improved Bluetooth device as shown in FIG. 34D. Device 1475 has external speaker (or ear bud) 1471 and external wire 1471a for transmitting audio signal (from a cell phone, for example) to the ear of the user. Specialized Bluetooth device 1475 has housing 1493 and two speaker assemblies for emitting sound: internal speaker 1469 which is physically integrated in housing 1493, and external speaker 1471 which is connected to housing 1493 through electrical connector 1477. This allows external speaker 1471 to be positioned in a location remote from housing 1493. External wire 1471a outside housing 1493 is connected to a single external speaker (ear bud) 1471, forming external speaker assembly 1473. External speaker assembly 1473 is preferably removably connected to device 1475 through female connector 1477. It is understood that assembly 1473 can also be permanently affixed to housing 1493. Both external speaker assembly 1473 and internal speaker 1469 connect to Bluetooth wireless communications system 1481, described in detail elsewhere in this application. Wire 1483 connects external speaker assembly 1473 and electrical connector 1477 in housing 1493 to Bluetooth wireless communications system 1481. Wire 1485 connects internal speaker 1469 in housing 1493 to Bluetooth wireless communications system 1481. Bluetooth wireless communications system 1481 contains a power source and all parts necessary for a 2-way wireless Bluetooth transmission of data. Specialized Bluetooth device 1475 further includes removably connected microphone assembly 1487, comprising stalk 1489 for transmitting sound and a microphone 1491. It is understood that microphone stalk 1489 can also be permanently affixed to housing 1493. Stalk 1489 can work as a voice tube, with its distal end connected to housing 1493 through connector 1501, which in turn is connected to Bluetooth wireless communications system 1481 through wire 1495. Housing 1493 can also include a built-in microphone (not shown).

Specialized Bluetooth device 1475 can be adapted to as an ear-supported device. Accordingly, housing 1493 further includes opening 1497 for receiving ear support assembly 1499. Therefore, specialized Bluetooth device 1475 can be an ear supported device (like, in some respects, prior art devices), which can create more discomfort by activating pain fibers of the sensitive anatomic region of the ear, or as a more comfortable and biologically fit device which does do not apply pressure directly against the ear. Because microphone assembly 1487 is removable and interchangeable with other devices, an assembly of different size and format can be used when device 1475 is supported by the ear using ear support assembly 1499. In an ear supported

application, ear bud 1471 is disconnected from housing 1493, and a shorter stalk 1489 for microphone assembly 1487 is preferably used. Alternatively, device 1475 can be attached to the temple of a user's eyeglasses using one of the attachment mechanisms described in connection with FIGS. 18-23C, or other attachment mechanisms. Housing 1493 can include an ear support assembly 1499 which is permanently affixed to the housing. In this embodiment ear support assembly may include a hinge and be foldable, and be articulated to give a compact configuration when the device 1475 is not supported by the ear.

The housing of the Bluetooth device of FIG. 34D can further include a clip-on or sliding-on structure, or any of the structures of FIGS. 18 to 23C. Therefore, the wireless communication device (illustrated as Bluetooth device) of the invention can function in a plurality of ways: stored in a storage cord (by virtue of the specialized ear bud and microphone assemblies), supported by the ear (by virtue of the internal speaker and ear support assembly), supported by the temple of the eyeglasses (by virtue of the clip and sliding mechanism).

FIG. 34E shows Bluetooth system 1503, comprising specialized eyewear storage cord 1505 and specialized Bluetooth device 1475. Bluetooth device 1475 has volume control button 1505, on/off switch 1507 for activating the device and receiving a signal from another Bluetooth device, female connector 1477 for connecting plug 1511 of external speaker assembly 1473, and a second connector 1501 for connecting stalk 1489 of microphone assembly 1487. Device 1475 can have another electrical connector 1521 for connecting to battery 1517. Specialized eyewear storage cord 1505 has right cord 1513 and left cord 1515, preferably disposed on opposite ends of a storage area 1509. Right sleeve 1519 and left sleeve 1521 as well specialized eyewear storage cord 1505 can be made of the same types of materials as the embodiment shown in FIG. 34. Storage area 1509 includes a pocket—preferably rectangular—preferably comprised of a plurality of elastic straps 1517 which covers its upper and side parts. This permits the user to access volume control 1505, on/off button 1507, and other controls and parts even when device 1475 is inside storage area 1509. Storage area 1509 can also hold extra battery. Although storage area 1509 is described as a “pocket”, it can also have a tunnel-like shape, thus allowing Bluetooth device 1475 to be placed in storage area 1509 from either the right or the left side. Arrow 1525 indicates device 1475 being placed in storage area 1509 from the left side, with battery 1517 located on the right side. Arrow 1527 indicates external speaker assembly 1473 being removably connected to connector 1477. Arrow 1529 indicates microphone assembly 1487 being removably connected to connector 1501. Preferred maximum dimensions for pocket 1509 are equal to or less than 15 cm in length, equal to or less than 10 cm in width, and equal to or less than 6 cm in height or thickness, and preferably equal to or less than 10 cm in length, equal to or less than 6 cm in width, and equal to or less than 4 cm in height or thickness, and most preferably equal to or less than 7 cm in length, equal to or less than 4 cm in width, and equal to or less than 2.5 cm in height. Storage area 1509 may be movable laterally relative to right cord 1513 and left cord 1515. Device 1475 can include in its body a fixed speaker assembly 1473 and/or fixed microphone assembly 1487.

FIG. 34F shows a Bluetooth system 1503 according to the present invention when worn by a user. Bluetooth system 1503 includes left sleeve 1521 of eyeglasses storage cord 1505 connected to left temple 1531 by encircling the free end of temple 1531. Storage cord 1505 retains Bluetooth

device 1475. Ear bud 1471 is positioned on ear 1533 through wire 1469. This allows the user to hear audio from the Bluetooth without having a bulky device pressing against his or her ear. Microphone 1491 is connected to Bluetooth device 1475 through stalk 1489, and located preferably under the ear, as shown in FIG. 34F. It will be understood that wire 1469 and wire 1489 can be from one wire, which runs under the ear, with the end split in two, with the upper end including speaker 1471 and positioned on the ear and the lower end including the microphone and positioned under the ear.

FIG. 34G shows another wearable article incorporating Bluetooth system 1503 of the invention that houses the device in a pocket of a head mounted gear such as a cap 1601. Specialized Bluetooth device 1475 is retained in pocket 1539 of cap 1601. Bluetooth device 1475 has connector 1603 for connecting to ear bud 1611, and second connector 1605 for connecting stalk 1607 and microphone 1609. Preferably, both connectors 1603 and 1605 are disposed on the bottom of device 1475 and retained by a pocket with similar construction as pocket 1509 and having straps 1517 for easily accessing buttons (as described in connection with FIG. 34E). Pockets 1539 and 1509 can have similar coiled cords and retractable cord spools in accordance with the invention for removing device 1475 from a pocket and viewing it. A mechanism for capturing voice through bone vibration can be integrated into ear bud 1611 and speaker assembly 1473.

FIG. 34H shows a kit according to the invention comprising Bluetooth device 1475, eyeglasses storage cord 1505, microphone assembly 1487, and external speaker assembly 1473 retained in box 1535. It is understood that cord 1505 can be replaced—or supplemented by a cap as described in connection with FIG. 34G.

The present invention teaches a device and method that uses a cord secured to temples of eyeglasses as an article that allows a user to better balance eyeglasses on his or her face and provide better weight distribution, while allowing the cord to have storage capabilities. The cord can work as a mechanical holder, and does not need electrical wires. The cord can have a pouch or pocket for retaining an electronic package such as a digital music player or a cellular phone, with ear buds working as a separate unit and connected directly to the music player while the two ends of the cord are secured to right and left side of the frame of the eyeglasses. It will be apparent to one of ordinary skill in the art that the cord can have more than one pouch, with a second pouch available for retaining ear buds, or a second electronic device, for example.

FIG. 34J shows an illustration of the specialized eyeglasses storage cord 1611 of the invention that includes a storage area 1613 such as a pocket or pouch, with two arms 1615 and 1617 disposed preferably on each side of storage area 1613. Storage area 1613 preferably includes a pocket with elastic capabilities and a combination of straps 1617 and openings 1619 similar to pocket 1509 of FIG. 34E. Right and left arms 1615 and 1617 terminates in right and left sleeves 1621 and 1623, which are shaped to embrace the free end of temples of eyeglasses (or other objects), which preferably measure preferably equal to or less than 1.8 cm in diameter or in the dimension of the free end, and most preferably equal to or less than 1.0 cm in diameter or in the dimension of the free end. Sleeves 1621 and 1623 slide on to the free end of temples for a snug fit regardless of temple size.

FIG. 34K shows another embodiment of the invention. Eyewear storage cord 1627 includes storage area 1629 for

housing an electronic package. Arms 1631 and 1633 are secured to storage area 1629. In this embodiment, arms 1631 and 1633 terminate in loop portions 1635 and 1637, which preferably are made of silicone or any deformable plastic. Sliding rings 1763 and 1765, preferably made of a rigid polymer such as PVC, are secured to the loops 1635 and 1637. Rings 1763 and 1765 can be moved longitudinally towards loops 1635 and 1637, closing them up and providing a snug fit to any size of temple or other object.

Pocket 1629 has slot 1641a, and is secured to cord 1639, preferably by stitching (shown by broken lines). Retractable cord 1641 (preferably a coiled cord) is secured to pocket 1629 by support 1643 (which can be, for example, a hard plastic attached to one of the walls of pocket 1629), with said cord terminating in holding structure 1645. Holding structure 1645 is preferably a plate that has a hook and loop surface. Plate 1645 is removably attached to an electronic package (not shown), by a hook and loop system, adhesive tape, or other fastening means.

It will be understood that loops 1635 and 1637 can be replaced with hooks, clips, or the like for securing cord 1627 to temples or other objects as a C-shape structure. To become operational, cord 1627 is preferably secured to temple of eyeglasses or another object. It is understood that pocket 1629, although a preferred embodiment, is not required, since the electronics package can be secured to plate 1645 with a retractable cord 1641, preferably as a spring loaded spool assembly, with said retractable cord 1641 being directly attached to cord 1639.

FIG. 34L shows a preferred embodiment of the invention comprising storage cord 1647 and an electronic package 1679 (such as a digital music player). Eyewear storage cord 1647 includes pocket 1669 and flexible arms 1649 and 1651, with right arm 1649 being in an extended position. The ends of arms 1649 and 1651 are essentially similar to the embodiment of FIG. 34k. Arms 1649 and 1651 house electrical jacks 1661 and 1663 for removably connecting with ear bud assemblies 1653 and 1655, as indicated by arrows 1657 and 1659. Right and left electrical jacks 1661 and 1663 are connected by wires 1665 and 1667 in arms 1649 and 1651 to support structure 1653 located inside pocket 1669. Support structure 1653 provides a fixation point, which allows ear bud assemblies 1653 and 1655 to remain stationary while the electronic package 1679 is pulled out of pocket 1669. Wires 1665 and 1667 are joined together at supporting plate 1653 and run together as wire portion 1671, which terminate as electrical connector 1673. Connector 1673 is removably connected to electrical connector 1675 of electronics package 1679. Pocket 1669 further includes support structure 1677, such as hard plastic glued to the pocket, for supporting coiled cord 1679 which terminates as plate 1681. Plate 1681 has means, such as a Velcro surface or adhesive tape, for being removably attached to area 1683 of electronic package 1679. Arms 1649 and 1651 can be removably secured to the temples of a pair of eyeglasses. Alternatively, the ends of arms 1649 and 1651 can be removably secured to a C-shape structure 1693, which is preferably made with a polymer, in order to create a system to be used around a portion of the body, such as the neck-shoulder area, head, arm, leg, abdomen, etc. Loops 1685 and 1687 slide on to the ends 1689 and 1691 of C-shape structure 1693, as indicated by arrows 1697 and 1699, and plastic rings 1693 and 1695 are used to create a snug fit.

FIG. 34M shows a two-piece device 1701, comprising eyewear storage cord 1703, and an essentially cylindrical C-shape structure 1705. Stretchable tubular ends 1711 and 1713 of cord 1703 are removably secured to ends 1707 and

1709 of structure 1705. Right cord 1264 is shown extended and partially folded, with stretchable sleeve 1713 shown in its stretched position and attached to end 1707 of structure 1705. Similar overlapping occurs when stretchable sleeve embrace the free end of temples of eyeglasses. Left cord 1266 is shown in its original position with stretchable sleeve 1711 in its relaxed position.

FIG. 34N shows a side view of three-piece eyewear storage cord 1715 that includes right arm 1719, left arm 1721, and support structure 1723, which is illustrated by a pouch for retaining an electronic package. Arms 1719 and 1721 are removably secured to support structure 1723 by encircling loops 1727 and 1729 of structure 1723. Right arm 1719 has two portions, lower portion 1723 and upper portion 1725. Lower portion 1723 and upper portion 1725 are removably attached to each other with hook and loop surfaces 1731 and 1733, as indicated by arrow 1735. The same system is used to attach the upper and lower portions of left arm 1721. Ends 1739 and 1741 of arms 1719 and 1721 terminate in a tubular stretchable portion, similar to the embodiment of FIG. 34.

FIG. 34O is a side top view of three piece eyewear storage cord 1715 of FIG. 34N showing right arm 1719, left arm 1721, and support structure 1723.

FIG. 34P shows a side view of another embodiment of the three piece eyewear storage cord of FIG. 34N. Housing 1743 has a cavity 1745, and a plate 1747 for supporting coiled cord 1749, which terminates in plate 1751. Plate 1751 includes means for being removably attached to an electronics package, such as a hook and loop fastener or adhesive tape. FIG. 34Q shows a kit including box 1753 which contains right arm 1719, left arm 1721, and support structure 1723, illustrated by a pouch for retaining an electronics package.

FIG. 34R shows an embodiment similar to embodiments of FIG. 34L and FIG. 34K when worn by a user 1775. Eyewear storage cord 1647 has an adjustable mechanism with extra length of cord for adjusting to different size heads. Loop portion 1635 of cord 1767 slides over temple 1761 and is secured tightly to it by sliding ring 1763. Cord 1767 houses wire 1769 and has pocket 1771 (for storing ear bud 1773) disposed next to loop portion 1635. Wire 1769 connects ear bud 1773 with electronic package 1679.

FIGS. 34S to 34V show an example of the manufacturing steps for producing an eyewear storage cord according to the invention using a single piece of material, such as neoprene. Neoprene piece 1777 has lateral parts 1779 and 1781 of equal dimensions, and one central part 1783. Lateral parts 1779 and 1781 are of smaller dimensions as compared to central part 1783 when laid flat, as represented by arrows 1783 and 1785. Central dimension 1783 is preferably equal to or less than 30 cm, and most preferably equal to or less than 20 cm, and even most preferably equal to or less than 15 cm. Lateral dimension 1785 is preferably equal to or less than 8.0 cm, and most preferably equal to or less than 3.0 cm, even most preferably equal to or less than 1.5 cm. Central part 1783 has edges 1787 and 1789. Right lateral part 1779 has edges 1791 and 1793, and left lateral part 1781 has edges 1795 and 1797.

In the first step, piece 1777 is laid flat as shown in FIG. 34V. Second, coiled cord/plate 1799 is attached, by gluing or sewing, to central part 1783, as shown in FIG. 34U. Third, edge 1787 is connected with edge 1789, preferably by stitches 1801, fourth, the edges of lateral parts 1779 and 1781 are attached to each other (edge 1791 to edge 1793, and edge 1795 to edge 1797), creating tubular structured at each end, and central tubular structure as shown in FIG. 34S. It

is understood that eyewear storage cord **1803** can be manufactured and work omitting the second step described above. FIG. **34T** is a perspective view of finished eyewear storage cord **1803** manufactured in accordance with the method described in connection with FIGS. **34S**, **34T** and **34U**.

FIG. **35** shows a preferred embodiment of the detachable electronic eyeglasses system **1320** of the invention worn by user **1330**, comprising detachable electronic eyeglasses **1300** and DEP **1302**. DEP **1302** comprises electronics package **1326** and cord **1328**. Detachable electronic eyeglasses **1300** houses wireless camera **1304** in temple **1306**. Temple **1306** also houses ear bud **1308**, wire **1310** for connecting camera **1304** to electrical connector **1314**, and wire **1312** for connecting ear bud **1308** to electrical connector **1314**. Although the drawing shows a large camera for purpose of illustration, the wireless camera can be small and housed in the temples in a non-noticeable manner to an external user. This is because, according to the invention, only micro optical systems and CCD are housed in the frame, which can have dimensions of few millimeters or less. The rest of the electronics (e.g. memory, wireless transmitter, and power source) for the camera are located in electronics package **1326** of DEP **1301**. It is understood that the electronics may not include wireless transmission, in which the standard electronics and parts of a camera are used.

An alternative embodiment might comprise only camera **1304** and wire **1310**, but not ear buds **1308**. This embodiment could be useful in military activities, where a soldier connects the DEP to his/her eyeglasses or goggles for performing a mission which includes capturing images. After the mission is complete, the DEP may be disconnected and the stored images downloaded for review. This allows a surveillance mission to be performed with a minimum of extra equipment, such as hand held cameras, because the light weight eyeglasses of the invention carry the camera with good weight distribution resulting by the DEP housing the bulk of the electronics.

Other devices can be miniaturized to be housed in the frame of eyeglasses, in accordance to the invention, by using a DEP which store large and heavier parts of the device. The frame of the eyeglasses of the invention might house, for example, a display such as a computer screen in the lens rim of the eyeglasses, while the main computing parts and memory stored away in the DEP.

FIG. **36** shows another embodiment of the detachable electronic system of the invention comprised of a different head-mounted wearable article—a hat. A detachable electronics hat system **1350** comprises DEP **1342** and detachable electronic hat **1340**. DEP **1342** includes electronics/power source in housing **1344**, and electrical connector **1346** which is releasably connected with electrical connection **1348** of detachable electronic hat **1340**. Detachable electronic hat **1340** includes ear bud **1352**, connected to retractable wire **1354** and spool **1356** securing wire **1358**. Wire **1358** has two ends, one end represented by wire **1354** connected to ear bud **1352**, and the opposite end represented by wire **1360** connected to electrical connection **1348**.

FIG. **37** shows another embodiment of the electrical pouch system of the invention, which can be used on a variety of wearable articles, including head mounted gear, clothing, and other articles, with said pouch being illustrated in a detachable electronics cap. Detachable electronics cap **1370** includes pouch **1380** formed by fabric material **1402**, with button **1401** for sealing pouch **1380**. Pouch **1380** has hole **1372** in one of its walls, through which wire portion **1374** enters pouch **1380**. Wire portion **1374** terminates in one end as an electrical plug **1378** (preferably a male plug)

while the other end of wire portion **1374** is secured to spring loaded wheel or spool **1376**, which allows wire portion **1374** to be extended and retracted. Spool **1376** also receives wire portion **1375** from the opposite side of cap **1370**. Wire portion **1374** is in electrical connection with wire portion **1384**. Wire portion **1384** terminates in second spring loaded spool **1386**, with wire portion **1384** being in electrical connection with wire portion **1388** secured to spool **1386**. Wire portion **1388** terminates at ear bud **1390**. Second pouch **1400**, illustrated as a sealed pouch, is formed by fabric material **1402**, has button **1403** for sealing pouch **1400**. Wire portion **1388** enters pouch **1400** through hole **1404**. A DEP (not shown) may be inserted into the pouch **1380** by means of slot **1406** within the fabric **1402**. Ear bud **1390** may be inserted—when not in use—into pouch **1400** by means of slot **1408** within fabric **1402**. Preferably, the wires and parts outside the pouches are disposed on the internal surface of the fabric, keeping the electrical and electronic system of the invention out of sight of an external observer, and not materially changing the appearance of the wearable article. Cap **1370** can include a microphone and/or a display means to improve its utility. A variety of materials can be used for fabric material **1402** including nylon, wear-resistant and moisture resistant cotton blend, synthetic material, plastic, canvas, leather, neoprene or other moisture-resistant or water-proof fabric or material to protect wiring and electrical connectors against moisture. Pouches **1380** and **1400** include a sealing mechanism such as buttons, zipper, clip, or the like to seal the pouch and to inhibit moisture or water from entering them. By placing the electronic device into electronic wearable cap **1370**, the user avoids placing pressure against the sensitive area of his or her ear.

FIG. **37A** shows a schematic view of the wire, spools, and connector assemblies of the cap of FIG. **37**, which are disposed preferably on the surface of the fabric material. This illustration can also apply to other embodiments for various head mounted gear, clothing, and other articles of manufacturing of the present invention. The pouch, wiring system, electrical connector, spool, and ear bud are substantially identical to each other such that description of features of left side herein applies to the right side as well. Electronic detachable gear system **1430** includes DEP **1440** and detachable electronic cap **1438**, including pouches **1380**, **1400**, spools **1376**, **1386**, wires **1374**, **1384**, **1388**, electrical plug **1378**, and ear bud **1390**. Preferably, pouch **1400** has sealing mechanism **1432**, such as a button, zipper, or velcro strip, which retains ear bud **1390**. Retractable wire portion **1388** is secured to spool **1386** and enters pouch **1400** through hole **1404**, with wire portion **1388** terminating at ear bud **1390**. Wire portion **1388** is electrically connected to wire portion **1384** via spool **1386**. Wire portion **1384** is preferably fixed and non-extendable, and connected to wire portion **1374** via spool **1376**. Retractable wire portion **1374** is secured to spool **1376** and enters pouch **1380** through hole **1372**. Wire portion **1374** terminates as male electrical plug **1378**, which is releasably connected with female electrical connector **1434** of electronics package **1436** of DEP **1440**, as shown by arrow A. Preferably, pouch **1380** has sealing assembly **1442** such as a button, zipper, or velcro strip, for retaining DEP **1440**. It is understood that spool connected to wires of ear buds may not be necessary, and the wire can have a regular configuration and by being anatomically fit the wires are short and can be folded when not in use. A variety of devices can be retained in pouch and not be electrically connected.

In an alternative embodiment, plug **1378** is surrounded by a plate, preferably having a Velcro surface or other fastening means, or being attached to the surface of plug **1378**.

Electronic devices having a Velcro surface can be removably connected to the plate and electrically connected to the ear bud assembly, thereby allowing an electronic device—such as a OPS device, a cellular phone, digital player and the like—to be connected to spool assembly **1376** and stored by pocket **1380**, but able to be removed by the user. When desired, user can connect the electronic device to plug **1378** and receive sound in ear bud **1390**. Pocket **1380** can also retain a DEP comprising a Bluetooth device which is electrically connected with plug **1378**, with said Bluetooth device receiving a wireless signal from a cellular phone or a digital music player. Thus, a small Bluetooth DEP could provide signal from another Bluetooth-enabled device stored at some distance from the wearable article. Any of the wearable articles of the invention can have a Bluetooth DEP that receives music from a cell phone, and when a call comes in the music stops for allowing receiving the phone call.

FIG. 37B shows another embodiment for head mounted gear according to the invention. Detachable electronic wrap-around article **1811** includes C-shape support structures **1813** and **1815** connected to ear buds **1817** and **1819**, and to cords **1821** and **1823**. Wrap-around article **1811** also houses wire portions **1825** and **1827** either within or on its structure. Wire portions **1825** and **1827** run either inside or on cords **1821** and **1823** and connect ear buds **1817** and **1819** with supporting plate **1829** inside pocket **1831**. At plate **1829** wires **1821** and **1823** are joined together to form wire portion **1833**, which terminates in coiled cord **1835** and electrical connector **1837**. Pocket **1831** is essentially similar to the pocket structures of the embodiments shown in FIGS. 37 and 37A, and in other embodiments described elsewhere in this application. Support structure **1813** and **1815** can include any configuration of ear supported assemblies described in this application.

FIG. 37C shows another embodiment of the invention. Detachable electronic goggles **1841** include front part **1847**—which hold the lenses **1847a**—and straps **1843** and **1845** disposed along the front part **1847**, and back portion **1875** connecting left strap **1843** to right strap **1845**. Straps **1843** and **1845** are essentially similar, and description of one apply equally to the other. Strap **1843** has portions **1849** and **1851**, and terminates in a third portion **1853**. Portion **1849** is disposed adjacent to front part **1847**, and includes pocket **1855** for retaining ear bud assembly **1857**. Ear bud assembly **1857** comprises ear bud **1861** and wire portion **1859**, which is shown in an extended position.

Portion **1849** has sub-portions **1863** and **1865**. Sub portion **1863** comprises a non-stretchable or minimally stretchable material such as nylon, and houses supporting structure **1867** that attaches wire portion **1859** to wall of pocket **1855**. Sub-portion **1865** includes the majority of pocket **1855** and is preferably made with a stretchable material such as elastic fabric. Portion **1851** comprises extendable wire portion **1869** secured to elastic strap **1871**. Extendable wire portion **1869** is disposed in an accordion configuration or any other stretchable configuration, and is adapted to match the tensile strength and length of elastic strap **1871**, allowing elastic strap **1871** to be stretched without creating undue tension in wire **1869**. Wire portion **1859** terminates in extendable wire portion **1869**, and wire portion **1869** terminates in wire portion **1873** inside back portion **1875**. Back portion **1875** includes pouch **1877** for retaining an electronics package (not shown). Pouch **1877** is essentially similar to the pockets of the embodiments shown in FIGS. 37 and 37A. Ear bud **1881** and coiled wire **1879** are shown inside pocket **1883** of right strap **1845**.

The wearable electronic articles of the invention, illustratively represented by eyeglasses, hats, neck mounted gear, head mounted gear, and the like, can include imaging systems as shown in FIG. 35. The wearable articles, such as the eyeglasses and hat, offer an added benefit of assisting in identifying an assailant. A person wearing the detachable electronic camera eyeglasses can have an image of the face of a potential assailant. Even if the assailant takes away or break the eyeglasses, since the image is immediately transmitted (either to the DEP or wirelessly) to a remote location, the face of assailant would have been captured. A DEP can store the image captured which could be downloaded, or preferably the DEP of the hat or eyeglasses or electronics of a storage cord includes wireless transmission of the signal (and thus image of the assailant). This may act as a deterrent against crime since potential assailants would not know if they were being filmed or were filmed during an attack. Since the invention requires only the micro optical system to be housed in the frame, children also can also use the system. Children can only wear small frames, which would be impossible to fit with a camera. Since the eyeglasses of the invention only hold the micro optical system which is small in size, they can be easily housed in the small frames worn by children, in the case of a DEP being worn as a detachable electronic cap, a DEP comprising a camera is preferably located on the side, with the pouch for the DEP preferably located on the side of the hat, and not on the back, thereby allowing easier viewing and filming.

Since the invention allows the camera to be extremely small, the frame can have multiple micro optical systems, such as one facing the back of the user and another facing the front of the user, allowing thus identifying an assailant coming from any direction. The system can therefore identify an assailant and even prevent a rape or kidnapping, or any crime. If an assailant saw the DEP, which is more visible, the assailant still would not know if the user has wireless camera capabilities. It is thus preferred to have electronics packages that do not identify the function being performed, to avoid an external observer to know if the user has a DEP with Bluetooth capabilities, MP3 capabilities, or wireless camera capabilities. A DEP with wireless camera capabilities and GPS capabilities would inform the location of the user as well as the image being recorded. Although a wireless camera can transmit images continuously, the only expense and work the user has is related to keeping a charged battery in the DEP. If the user prefers only to record in certain occasions, the DEP can have a voice activated system for initiating recording only when requested by the user. As such, a code word such as “action” or “record” can be used for activating the wireless camera. This function would help preserve power, and would be of interest for instance, by a camper recording a certain trail or scenery, or a person being followed recording a possible assailant. When there is suspicious activity, the user can give a voice command to activate the camera, or can press an activation button in the DEP allowing both recording of images and giving position through a GPS system.

FIG. 38 shows another embodiment of the invention. Detachable electronic shirt system **1450** is worn by user **1451** (depicted in phantom lines) and comprises DEP **1460** and detachable electronic shirt **1470**. Left side of collar **1472** is shown in a lifted position to illustrate pouch **1464** on the inside face of the fabric of collar **1472** for retaining ear bud **1476** and spool **1478**. Wire portion **1474** extends for positioning ear bud **1476** on ear **1475**. On the right side, wire portion **1484** is connected to DEP **1460**. Wire **1484** is in an extended position to enable viewing of the display of

electronics package 1480. Pouch 1462 on the right side of collar 1472 is shown in a sealed position. Cavity spool 1498 and ear bud 1496 are retained inside pouch 1462.

To use this embodiment of the invention, the user lifts the free end of collar 1472 to expose pouch 1464, and then extends wire portion 1474 to position ear bud 1476 on ear 1475. Likewise, upon pulling wire portion 1484, electronics package 1480 is removed from pouch 1486 and positioned in line with the visual axis of the eyes 1481, as shown by arrow B. Wire portion 1484 has male plug 1488, which is connected to female plug 1492 of electronic package 1480. Wire portion 1500, secured to spool 1498, exits collar 1472 and enters chest portion 1502 of shirt 1470 for connecting with spool 1482. Left wire portion 1504 is secured to spool 1478 and disposed on collar 1472. Left wire portion 1504 is disposed on collar 1472 from the left side to the right side and terminates at spool 1482, after joining right wire portion 1500 to form cable 1506.

In this embodiment, in order to facilitate manufacturing, pouches 1462 and 1464 retain both spool and ear bud, while pouch 1486 retains both DEP and spool. Although pouch 1486 is disposed on the front part of shirt, pouch 1486 can alternatively be disposed on collar 1472 or on the back part of the shirt in close proximity to collar.

Although this embodiment uses retractable wires and spools, it will be understood that standard wires can be used in addition to robotic arms, telescopic assemblies, or the like can be used instead of the retractable wire/spool system for extending ear buds and electrical plugs. It will also be understood that Velcro fasteners can be used to attach the DEP and ear buds to the wearable article, such as the cap and shirt, instead of using pouches.

Although only a few exemplary embodiments were described in detail, it will be apparent to one of ordinary skill in the art that the invention can be modified to accommodate other wearable articles. A variety of wearable articles can be used, in accordance with the invention, including clothing in general (such ties, jackets, snow hat, arm band, etc.), head mounted gear (such as goggles, visors, head bands, wrap around ear assembly, helmets, silicon caps for swimmers, eye masks for sleeping, etc.), neck mounted gear (such as scarves, bands, necklaces, etc.) and personal items (such as wallet, purses, baby carriers, cases of eyeglasses clipped to a shirt or pants, etc.), allowing thus the user to have access to electronic functionality using a variety of articles. For example, all of those articles can have anchoring means for anchoring a storage cord of this invention. By way of further illustration, detachable electronically-enabled goggles according to the invention, such as ski goggles or swimming goggles, include a pouch in the back portion of the strap which retains the spool and DEP, and one pouch on each side of the strap for retaining a spool and ear bud in conjunction with the other features of the invention. Any wearable or personal article can have complimentary anchoring means that connect to complimentary anchoring means on the storage cord of this invention.

Virtual imaging eyewear, digital imaging eyewear, and infrared imaging eyewear can, in accordance with the invention, be made light weight and without wires, with only the optics and silicon microdisplay being in front of the eye, while the electronics and smart parts are housed in the DEP in a detachable or permanent manner and away from the front portion of the eyewear. Accordingly, a virtual imaging eyewear, in accordance to the invention, allows complete portability with no wires attached to the eyewear when playing a game, as found in the prior art. With the present invention, the display is disposed in the front part of the

eyewear for viewing the game, with a DEP working as a retractable game control housed at the back of the head. When in use, the extendable cord is extended, allowing the game control to be brought into the user's view. After the game is finished, the extendable cord is retracted, and the game control is stored in the cradle-like housing of the DEP.

Because the present invention allows a cost-effective way to electronically enable an article, it will be also apparent to one of ordinary skill in the art to modify the present invention to use it in conjunction with non-wearable articles. For example, a back pack can be adapted with a detachable system including a storage cord according to the invention, preferably in its upper part because of its proximity to the eyes and ear of the user, and providing therefore sound and electronic function in a hands-free manner. Other examples of articles which can be electronically enabled are pillows, head rest of arm chairs, desks, etc. In such articles, the articles houses the DEP, ear buds and other assemblies of the present invention, allowing the user to remove the DEP from a hat and plug the same DEP into the desk while working. The DEP can be attached to the article using a pair of "arms" shaped like the temples of eyeglasses attached to the article. The arms or buttons can be permanently affixed to the article, or they can have an adhesive surface and be removable, allowing the same set of arms to be used on multiple items, for example a desk, or the fold down tray on a airplane. Alternatively, the DEP can be attached to the article using Velcro strips, or a series of snaps or buttons, or a hook and groove system. The means of attachment is not critical, but can be chosen to accommodate various need (eg., ease of removal, stability of attachment, etc. A variety of furniture in close proximity to the head can also be adapted to receive the system of the invention such as head board of a bed. It is also understood and apparent to one of skill in the art that other articles such as a bicycle, a treadmill, and other articles can advantageously receive the detachable system and assemblies of the present invention.

It will also be understood that a retractable wire and spool can be attached to the electronics package such as a music player, allowing the electronics package to be moved to the user's visual axis and replaced without undue risk of dropping it. In this embodiment, the retractable wire connected to the electronic package has a connector which connects with a connector of the storage cord. The storage cord in this embodiment does not require a spool (such as in the embodiment of FIG. 200C) since the electronic device already has a retractable wire assembly.

It is understood that a variety of head gear, clothing, and footwear can be used in accordance with the principles of the invention. For instance, clothing can house ear buds and electrical connectors, which can be releasably connected to a DEP, with said DEP being located anywhere in a piece of clothing on the body, but away from the gear housing the ear buds.

In one embodiment, the ear buds and wire are preferably housed in a water-proof housing in the collar. A two DEP system can also be used, in which a DEP secured to a piece of footwear sends a wireless signal to a DEP secured to a cap or eyeglasses, allowing thus information such as foot activity, distance, temperature or circulation to be transmitted to a second DEP adapted to inform the user or display the data being received from the DEP in the footwear.

In addition, a sound signal from a music player can be sent to a wireless ear bud. Furthermore, the music player may be connected with a pedometer, and music played according to the distance ran.

For example, a user can program music according to the route and terrain and when mile three is reached which is known to be a hill, for example, different music starts. Thus, the invention teaches a device and method that allows programming music to coincide with terrain, distance, speed, expected level of difficulty, and the like. The song or audio (such as voice of a person) is triggered by a certain event, including distance ran, heart rate level, temperature level and terrain. Certain marks of those events execute a function to find a music or audio previously selected.

The system includes a digital device such as a music player or an imaging display device as a first device and a second device, such as a pedometer, heart rate monitor, temperature monitor, GPS and the like, the second device generating a signal based on a previously selected event calls up a previously selected song. The first device and second device can be connected by wired or wireless means. The system includes a processing circuit that identifies the signal from the second device, and executes a function in the first device based on the stored instruction (such as name of a song).

By way of example, a marathon runner uses their heart rate level to trigger a song that optimizes performance. If at the beginning of the race the pedometer indicates a distance of less than five miles and the heart rate is too fast (such as 180 bpm), the combined signal of distance and heart rate triggers a song that is more conducive to running at a lower speed. When the route is known, such as in a marathon, the user can program the type of music based on distance ran measured by the pedometer. When the system includes a GPS, whenever the terrain has an incline, the program executes a previously selected power song or the voice of a drill sergeant. The user selects a song or audio recording that is stored in memory of the first device and that is called up when certain trigger events occur according to the second device.

Another embodiment includes a helmet (such as a bike helmet or a firefighter's helmet) with ear buds, wire and electrical connections permanently housed in the helmet. In one embodiment of a detachable electronic helmet system, the DEP preferably houses a wireless communication system for communicating instructions for instance between a fire chief and a firefighter or between a coach and an athlete. The invention provides an extremely cost-effective system since the low cost parts such as the ear bud, wire and electrical plug are preferably permanently housed in the head mounted gear such as the helmet while the expensive parts are housed in the DEP. Because the expensive parts are detachable, the firefighter or athlete can remove the DEP from the helmet which was used for receiving instructions during work, and now said firefighter or athlete can connect the DEP to their sunglasses and receive a wireless signal for instance from a satellite radio station for enjoying music while wearing sunglasses that only house low cost parts. Thus the invention provides another unique benefit, which is equal use of the invention for work, and for entertainment. The invention also allows maximizing the use of a device, for example by avoiding an expensive wireless system to sit idle for a long time. By being versatile the invention allows continue use of the electronic package in any occasion. Otherwise, the wireless capabilities only would be available when wearing the helmet in question, significantly limiting therefore the use of the device. The invention thus provides methods such as for miniaturizing devices in wearable articles by reducing the parts disposed in the wearable article and to maximize use of the devices. The storage cord of the

invention, by accepting universally different electronic devices, can provide all of the above benefits while being low cost.

Of course, it is also possible to permanently house the entire system in the helmet, particularly when the electronics device might be specialized (e.g. for a fire helmet), or when the user might not want to wear anything other than the helmet. For example, a biker could have the device built into her bike helmet, allowing her to listen to music whilst biking. By pulling the device out from the storage compartment on the helmet—by using the retractable cord—the user could see the device to make music selections, for example, and could then let the cord pull the device back to the storage compartment, allowing for hands-free use.

The invention also teaches and provides significant improvements to prior art eyeglasses which house heavy electronics and unsightly ear buds on a permanent basis, it does so by permitting visual interaction with the electronic components. By using the retractable wire assembly and cradle-like housing described in FIGS. 1D and 1E, the electronic and a display can be brought to the visual axis of the eye of the user.

It will be that in order to avoid having wires passing through a hinge mechanism, for example when a display is housed in the lens rim, as illustrated in FIG. 13) the invention preferably uses an electrical connection in the temples that includes an electromagnetic switch. An example of such a switch is the Reed switch, described in U.S. Patent Application Nos. 20040059212 and 20040242976. A slip-on display can be also be used, with the display being electrically connected with the frame of the eyeglasses, and the eyeglasses being connected to a DEP.

It is also understood that a variety of devices for measuring biological parameters such as contact lenses, devices inside the eye, or on the surface of the eye, and many other devices and sensors described in U.S. Pat. No. 6,544,193 and in U.S. Patent Application Nos. 20040059212 and 20040242976—the disclosures of which are hereby incorporated by reference—can be used in accordance to the present invention. Accordingly, a device described in one of the foregoing patents or patent applications can have its parts divided between the original device and the DEP. This limits the number of electronic parts housed in the eyeglasses.

It will also be understood that eyeglasses that house a coil to power another device by electromagnetic induction, such as a passive contact lens described in U.S. Pat. No. 6,544, 193, can be used in accordance with the present invention. The lens rim can house the coils, with the power source being housed in the DEP. It will be further understood in certain functions characterized by a large or heavy DEP, small batteries can be housed in the temples of the eyeglasses, with the main electronics and hard drive housed in a DEP.

The invention can also include adhesive or attachment means to secure the DEP to clothing, which is preferably used in case of heavy DEP. For example, a DEP of eyeglasses having a hook-and-loop strip (Velcro) can be attached to a Velcro in the collar of a shirt reducing therefore the amount of weight applied to the eyeglasses.

Other gear can also be used in accordance to the invention, including any of the head mounted gear described in U.S. Patent Application Nos. 20040059212 and 20040242976. For example, a detachable electronic eye mask from the foregoing applications may be wore by a user who plugs it into a DEP comprising of digital music player. The user may then enjoy music while laying on the beach

and having his/her eyes covered and protected. When the user is in bed, he or she can still enjoy music wearing the eye mask of the invention, but before falling asleep can unplug the DEP, removing a heavier piece which can limit comfort during sleep.

The present invention also provides a system that includes another wearable article such as shoulder supported housing and a generally C-shaped structure with a cavity sized to accept an electronic package such as a cellular telephone, a digital music player (e.g., MP3 player), a video player, and the like.

FIG. 39 shows a wearable electronic device 1550 worn on the shoulder of a user (shown drawn in phantom lines). Shoulder wearable electronic device 1550 preferably includes generally "C"-shaped (or inverted U-shape) housing 1560. Preferably, the C-shaped housing covers at least 180 degrees. Opening 1552 is sized to permit housing 1560 to pass around neck 1554 (or other body portion) of a user. Opening 1552 distributes the weight of electronic device 1550 between the shoulder and the neck. Preferably, the C-shaped housing is adapted to remain at least 2.5 cm from the side of neck, reducing the likelihood of activating of pain fibers and limiting discomfort. C-shaped housing 1560 fits comfortably around a small portion of the user's neck, and is preferably held in place on the surface of the body by gravity and support of a body part, and not by straps or other fastening means.

In a preferred embodiment, housing 1560 is formed of a polymeric material and includes cavity 1555 for retaining electronics package 1556, in a similar manner as described in connection with FIGS. 2B and 2C. Retractable wire 1558 and spool 1562 are connected to electronics package 1556. Ear buds 1562 and 1564 are disposed in a diametrically opposed fashion at the right and left side of housing 1560 and are connected by wires 1566 and 1568 to spools 1570 and 1572, speaker 1588. Microphone 1574 is disposed at end 1576 of housing 1560; display 1578 is disposed at opposite end 1580 of housing 1560. A coiled wire with retracting capabilities can also be used instead of retractable wires with spools, and in this embodiment shown in FIG. 39, there are no spools.

Housing 1560 also includes power source 1582, which is preferably located adjacent to cavity 1555 and held in the back portion of housing 1560. To facilitate illustration cavity 1555 and electronics package 1556 are shown in the back portion of housing 1560; however it is understood they may be disposed on either side of the housing 1560, or they can be disposed on opposite sides. Electronics package 1556, such as a cell phone, is releasably secured in the cavity 1555 through electrical connector 1590. Electrical connector 1590 is connected to spool 1562. Electronics package 1556 is connected by a wire system that includes a spool and retractable wires or by coiled cords or a combination of coiled cords and spool-based cords, to ear buds in accordance to previous description of the invention. It will be appreciated that the various parts disposed within or on housing 1560, such as ear buds, microphone, speaker, electronic circuit, display, power source, and the electronics package are electrically connected by standard wiring systems, which are not shown.

When the device is worn, the microphone is in close proximity to the mouth, and the display is within the visual axis of the eyes to permit, for example seeing a caller ID number. Housing 1560 preferably includes hinge assemblies 1608 and 1610, to allow arms 1612 and 1614 to fold upon each other. This facilitates storage of the device by reducing its size by about two thirds.

Although a C-shaped structure has been described as the preferred embodiment, other shapes, such as square shapes, pentagonal shapes, or other polygonal shapes, can be used, without departing from the scope of the invention. Preferably, the largest width (or height) of cavity 1555 or housing 1560 is equal to or less than 15 cm, and most preferably equal to or less than 11 cm, and even most preferably equal to or less than 7 cm. The preferred longest distance of the center point of the support structure (illustrated herein as C-shaped structure) to the outer edge of the support structure is equal to or less than 28 cm, and preferably equal to or less than 20 cm, and even preferably equal to or less than 13 cm. The preferred shortest distance of the center point of the support structure (illustrated herein as C-shaped structure) to the outer edge of the support structure is equal to or more than 9 cm, and preferably equal to or more than 11 cm, and even preferably equal to or more than 13 cm. The structure comprises an opening, and disposed within the structure an ear bud, wires, and a cavity sized to accept an electronic package.

FIG. 39A shows an embodiment of similar to the embodiment of FIG. 39, with two additional parts: large video display 1592 attached to housing 1560 by telescopic and retractable/extendable arm 1594, and removable cord 1596. The electronics package in this embodiment is video player 1595, which is positioned in cavity 1555 and connected by electrical connector 1590. The detachable electronic system can be operable from a motor vehicle 12 VDC cigarette plug accessory voltage or AC outlet through cord 1596, and can charge electronics package 1595 when not in use.

It is understood that housing 1560 can house a plurality of electronic devices, for example a cellular phone/MP3 player on the right side and an electronic organizer (such as a Palm device from Palm, Inc.) on the left side. Likewise, a radio or other electronic devices described in the present invention can be housed in structure 1560 and creates an anatomically fit wearable electronic article in accordance to the principles of the invention.

FIG. 39B shows an embodiment in which electronics package 1556, exemplified as a cellular phone or cordless phone, is not electrically attached to housing 1560. Electronics package 1556 is shown away from housing 1560. In this embodiment, electronics package 1556 can be mechanically retained in cavity 1555 by release button 1598. Electronics package 1556 communicates by wireless means with housing 1560. In a preferred embodiment, electrical pads 1600 disposed in cavity 1555 are coupled to a power supply in housing 1560 and permit recharging the internal battery within electronic package 1556. Electrical pads 1600 are sized and positioned to contact associated electrical pads (not shown) on electronics package 1556. The main electronics, power supply, long range receiver/transmitter for cellular phones, and heavier and large circuits (collectively called main parts 1602) are housed in housing 1560, allowing the hand held portion of the cellular phone (or cordless phone) to be miniaturized, with only a small thin battery and a small low power transmitter/receiver microchip circuit for short range transmissions being housed in the hand held portion. By having only few and very small parts, for example thin dial pad 1620, display 1622, built-in microphone 1624 and speaker 1626, electronics package 1556 can have small dimensions such as a credit card or small calculator, as shown in FIG. 39B and be carried in a wallet. Because housing 1560 is preferably foldable, housing 1560 can carried in a brief case or pocket of a jacket while remaining in wireless communication with the credit card-like cell phone of the invention.

The same benefit applies to a DEP housed in eyeglasses or other head mounted gear such as a hat, etc., allowing the user to carry a credit card like cellular phone while the main parts of the cellular phone are hidden away out of sight and comfortably stored in an article already being worn by the user, enhancing the utility of that wearable article.

FIG. 40 is an illustration of an embodiment of the invention: a properly weight distributed and anatomically fit inverted U-shape wearable computer 2000 worn by a user 2001. Computer 2000 has an inverted U-shape structure 2002 with arms 2004 and 2006 spaced apart. Arm 2004 has keyboard 2008 disposed at its end. Arm 2006 has display 2010 disposed at its end. Inverted U-shape structure 2001 is, preferably, substantially cylindrical, and preferably comprises at least one adjustably extendable and bendable portion. Arm 2004 has adjustably bendable portion 2016 and adjustably extendable portion 2012. Extendable portion 2012 is shown in an extended position with clasp assembly 2014 in an open position, allowing full extension of extendable portion 2012. Bendable portion 2016 terminates proximally in extendable portion 2012 and terminates distally in housing 2018 secured to keyboard 2008. Arm 2006 has adjustably bendable portion 2020 and adjustably extendable portion 2022. Bendable portion 2020, shown in a bent position, terminates proximally in an extendable portion 2022 and terminates distally in a housing 2024, which is secured to display 2010. Inverted U-shape wearable computer 2002 further comprises back portion 2026 disposed between extendable portions 2012 and 2022, and cable 2028. Cable 2028 is connected to computer electronics housing 2030, which houses computer electronic parts and power source (not shown). For example, housing 2030 may house a power source, CPU, hard drive, disk drive, RAM, network card, video card, sound card, wireless transmitter, modem, ports, connectors for display 2010 and keyboard 2008, and other electrical connectors, card slots, and other computer hardware. Cable 2028 is preferably connected to housing 2030 through retractable spool cord assembly 2032. Housing 2030 can also include fan and other heat dissipating mechanism. Display 2010 can function as a standard display monitor for computers, a display for tablet-PC, and the like.

Preferred embodiment for the extendable and flexible portions of the inverted U-shape wearable computer will be described in detail. FIG. 41 shows wearable computer 2000 that includes extendable portion 2012, illustrated by an accordion tube, which remains in a compressed position by tooth 2034 of clasp assembly 2014. A preferred embodiment also includes an adjustably extendable spinal portion, which functions as a human spine configuration. Extendable accordion tube 2012 may be extended from the compressed position by lifting arm 2036 connected to tooth 2034 of clasp assembly 2014. Accordion portion 2012 may be axially compressed from an extended position to a compressed position and held in place by a stop mechanism, illustrated herein by clasp assembly 2014. Accordion portion 2012 can be made of any material, but is preferably made with a polymer, rubber, or metal, most preferably with a polymer such as silicone or a combination polymer and rubber. Wearable inverted U-shape computer 2000 also includes flexible portion 2016, which can be extended, but preferably has only bendable and flexible characteristics, and is sturdy enough to provide stable support for keyboard 2008. For example, flexible portion 2016 may include a flexible metallic gooseneck portion, such as for example, one manufactured by Littlite Company of Hamburg, Mich., 48139, USA, and a variety of memory shape alloys, with said

flexible portion 2016 being made of material that has memory and can support about 500 to 600 grams of weight.

Flexible portion 2016 terminates in housing 2018 at rotating wheel 2038, with part of portion 2016 running directly adjacent to keyboard 2008. Extendable accordion portion 2012 terminates in upper portion 2040, which connects arm 2004 to arm 2006. Upper portion preferably has plate 2042, with plate 2042 resting against the neck of the user. Plate 2042 is preferably is made of a flexible material which can conform to the shape of the user's neck, like polymer or rubber, and has two functions: (1) to distribute the weight and increase the surface area resting on the neck and thus reduce localized pressure which can more easily activate pain fibers, (2) increase resistance to motion of the cord of the pulley system of the invention during use of the wearable computer 2000 and typing on keyboard 2008.

Upper portion 2040 is preferably non-extendable and houses electrical connector 2046 to connect to a conventional ear bud assembly and a microphone 2048. It is understood that upper portion can also have two connectors for ear buds (not shown) on right and left side of upper portion 2040, and pockets on each side, and a speaker. It is also understood that upper portion 2040 can be entirely comprised of an accordion tube for extending the length of wearable computer of the invention. Upper portion 2040 terminates in a second extendable accordion portion 2022, which is shown in an extended position, and has essentially the same characteristics of extendable portion 2012. Extendable accordion portion 2022 has clasp assembly 2050 and tooth 2054, which is shown in the full open position illustrated by arrow 2056, allowing accordion portion 2022 to be fully extended. Accordion portion 2022 terminates in flexible portion 2020, which has essentially the same characteristics as flexible portion 2016. Flexible portion 2020 terminates in housing 2052, which is similar to housing 2018. Housing 2052 is connected to display 2010. Wiring 2070 for electrically connecting the various parts of the wearable computer, including keyboard, display, microphone, speakers and the like, is preferably housed inside an inverted U-shape structure 2001. Preferably, the maximum dimension of the inverted U-shape structure 2001 is equal to or less than 4.0 cm in diameter, more preferably equal to or less than 3.5 cm, and most preferably equal to or less than 2.5 cm. Preferably, keyboard 2008 is removably connected to computer electronic housing 2030 through cable 2028.

During use, the wearer uses a stop mechanism to change wearable computer 2000 from a compact format, which is anatomically fit to an extended format for use. An exemplary stop mechanism includes clasp assembly 2014. By lifting tooth 2034, portion 2012 can be extended. The keyboard is then rotated from a vertical position to a horizontal position using rotating wheel 2038. Flexible gooseneck portion 2016 is then adjusted to position keyboard at a proper angle and height. Essentially the same steps apply to the opposite side for positioning display 2010 in line with the eyes. After proper positioning, inverted U-shape wearable computer 2000 is activated by pushing an on switch, preferably located in the computer electronic housing 2030.

It will be understood that an accordion portion or spinal portion with memory and elongation capabilities can be used without the need for a gooseneck portion. Accordingly, FIG. 42A shows compressed adjustably extendable portions, illustrated herein as accordion portions 2058 and 2060. Accordion portion 2058 is connected to display 2064, and accordion portion 2060 is connected to keyboard 2062, which in turn is further connected to computer electronic housing 2066. FIG. 42B illustrates extendable accordion

portion **2058** in an extended and bent position, and extendable accordion portion **2060** extended for use. Accordion portions **2058** and **2060** can be covered by tubular cover of vinyl, rubber, silicone, or the like for enhancing comfort.

Although the extendable portion of the wearable computer according to the invention can use an accordion tube for compressing and extending, other extendable means can be used. FIGS. **43A** to **43H** show a plurality of exemplary embodiments illustrating the extendable portion of inverted U-shape computer **2000**. FIG. **43A** shows a telescopic or antenna assembly **2068** in closed position, while FIG. **43B** shows telescopic assembly **2068** in extended position. FIG. **43C** shows a tooth-groove assembly **2070** comprising plates **2072** and **2074** in a partially extended position. Plate **2072** slides on top of plate **2074** with tooth **2076** being retained by groove **2078**, using forward and rearward motions. FIG. **43D** shows spring assembly **2080**, with the spring kept in compressed position by clasp assembly **2082**. When clasp assembly **2082** is released, spring **2081** is released, extending the arm. FIG. **43E** shows articulated arm assembly **2084**, partially extended and connected to display **2049**. FIG. **43F** shows sliding plate assembly **2086**, comprising plates **2088** and pins **2090**, in a partially extended position. Plates **2088** are stacked on top of each other, and when pulled, the top plate is released increasing the length of assembly **2086**. FIG. **43G** shows a spinal assembly including ball articulated assembly in three positions: compressed position **2094**; extended position **2096**; and extended and bent position **2098**. FIG. **43H** shows a cut way view of assembly **2098**.

As can be observed from FIGS. **43A-H**, some extendable assemblies can function as both extendable and flexible assemblies. It will be understood that wire(s) housed inside the extendable portion is(are) adapted to extend in accordance to the configuration of the housing. For example, an accordion tube houses a wire that has an accordion configuration.

A clasp assembly allows adjusting keyboard and display to different heights in accordance to the needs of the user. FIG. **44A** illustrates tooth **2102** of clasp assembly **2100** holding extendable accordion portion **2104** in compressed position. FIG. **44B** shows accordion portion **2104** in a partially extended position. FIG. **44C** shows self-adjusting clasp assembly **2106** with elongation capabilities and having sliding arms **2108** and **2110** in extended position, with tooth **2112** holding accordion portion **2104** in a compressed position. FIG. **44D** shows accordion portion **2104** partially extended with arm **2108** partially overlapping arm **2110**. The clasp assembly has an arm that preferably functions as a cantilever.

FIGS. **45A** and **45B** shows illustrations of different height of keyboard provided by the clasp assembly of FIGS. **44A** to **44D**. FIG. **45A** shows a user wearing inverted U-shape computer **2000** with extendable portion **2012** in partially extended position, which positions keyboard **2008** at the level of upper abdomen **2112**. Arrow **2122** illustrates the downward motion that can occur when typing, and considering the pulley system of the invention, there is an increase in tension in the cord of the arm **2004** secured to the keyboard **2008** which can lead to acceleration and motion in the opposite cord holding the display **2010**. To minimize any motion of display **2010** during typing, cable **2116**—connected to computer electronics housing **2030**—is preferably secured to connector **2120**, therefore counteracting the potential increased tension in the opposite cord during typing. Arrow **2121** illustrated the increase in tension in the display side by connecting arm **2006** to computer electronics housing **2030**. In this embodiment, wire from display **2101**

and wire from keyboard **2008** inside U-shape tube structure terminates at connector **2120**. Computer electronics housing **2030** (shown in broken lines) can be retained by pocket **2119** of a jacket, as illustrated in the figure, or in some other convenient manner, such as in a purse, back-pack, clipped to a belt, and the like.

FIG. **45B** shows a preferred embodiment of the wearable computer of the invention when worn by a user (shown in phantom lines) in full extended position. Accordion portion **2012** is fully extended and stop mechanism **2114** is fully opened. Flexible gooseneck arm **2016** holds keyboard **2008** in a stable position for typing at the waist level. Display **2010** is held within visual field of the eyes of the user. Connecting cable **2116** removably connects computer electronics housing **2030** to a connector **2120** located at the end of flexible portion **2020** connected to display **2010**. It is understood that electronics housing **2030** is not needed for the invention. All the computer components can be disposed in the keyboard and display, with the weight preferably divided in a similar manner between the keyboard and the display.

The wearable computer includes a combination of adjustably positionable arms and adjustably extendable arms, being disposed in the two side of the U-shape structure, structure. It is also understood that a variety of supporting means can be used for the wearable computer. Accordingly, FIG. **45C** shows a user wearing inverted U-shape computer **2000** with display **2010a** including a bi-pod system **2010b** for resting against the body. A tripod also can be used for the keyboard, which is further held in place by clips secured to a piece of clothing. FIG. **45D** shows a preferred spinal configuration for the wearable computer **2000a**, including a display **2010c** having a tripod attachment **2010d** and one adjustably extendable portion **2012a** being compressed while the opposite adjustably extendable portion **2012b** being in an extended position. Any type of stop assembly or mechanism can be used including portable hand held devices separated from the wearable computer **2000a**, exemplified herein as clip **2012c**.

FIG. **45E** shows a kit including a box **2000b**, an inverted U-shaped structure **2000c** having two arms **2000d** and **2000e**, each arm having a holding structure **2000f** and **2000g** for holding a display and a keyboard, and further including a display **2010**, keyboard **2008**, and computer hardware portion with cable **2000h**.

FIG. **45F** shows the preferred spinal configuration for the wearable computer. The spinal configuration allows increasing the length of the arm without increasing the diameter of the arm as can be seen in spinal portion **2001a** (reduced length) and **2001b** (increased length), in which the length of each section is increased by reducing the size of the sphere **2001c** connecting the parts. The tubular shape also provides more comfortable wear. FIG. **45G** is a cut away view of the spinal configuration showing first part **2001b** with ability to extend longer than second part **2001a**.

It is also understood that the wearable computer of this invention can be worn as a strap, a sling or made in a vest version with extra pockets. The screen is attached to a gooseneck arm that allows it to be positioned draping it across the neck which allows for extra stability. The screen is detachable to allow it to set on a table or be hung from the back of a seat, etc. A main pocket secured to the side of the body of the user holds the hard drive, motherboard, modem, USB card, and the like. The keyboard has two legs with clips at the end that attach to the belt to hold it up. The keyboard may also have on the front underside three legs that are attached to a pad (or three pads) that rest on the stomach to

61

give it support. The keyboard may also be used setting on a tabletop or resting in the lap it, and also has its own pocket for storage when not in use.

The invention also teaches a method for typing on a keyboard with both hands while laying on a supine position. Since the method and device of the present invention allows positioning the keyboard and display in any angle and position, the wearable computer can be used with the body in any position, including laying down. FIG. 46 shows wearable computer 2000, worn by a user who is laying down and typing. It includes the parts already described such as keyboard 2008, display 2010, inverted U-shape structure 2002, flexible portions 2016 and 2020, and computer electronics housing 2030. Flexible portions 2016 and 2020 can be twisted to arm keyboard 2008 and display 2010 in any direction and to be placed in the desired anatomic position. Display 2010 is shown close to the face of the user for illustrative purposes to show the display in line with the eyes while the keyboard is held in a position that is harmony with the anatomy of the hands and elbow for typing. Cable 2130 removably connects computer housing 2030 to keyboard 2008 through electrical connector 2132. Computer housing 2030 is held at waist level by clipping it to the pants of the user, and DVD player/writer 2134, resting on the floor, is removably connected to computer housing through cable 2136.

While not in use, the extendable portions of the wearable computer 2000 are compressed and the display and keyboard are held in a vertical position to fit with the anatomy of the body. During use, the system is extended and the display and keyboard are moved from a vertical to a horizontal position.

FIG. 47 shows inverted U-shape computer 2000 worn by a user with the extendable portions fully compressed for carrying the device and also disconnected from computer housing 2118. When fully compressed, in accordance to the invention, wearable computer 2000 is barely visible under a regular jacket, with only part of the display 2010 and keyboard 2008 being noticeable. Special pockets in the jacket can retain the computer 2000 and not be noticeable to an external observer.

FIG. 48 shows in more detail rotating wheel assembly 2124, which connects flexible gooseneck portion 2126 to keyboard 2008. Wheel assembly 2124 functions as a cog-wheel, and has 360 degree angle rotation illustrated by arrow 2128. A similar rotating wheel assembly can connect an arm of the system to the display on the opposite side. The rotating wheel assembly can be replaced by a ball assembly for rotation in more than one axis. FIG. 48A shows keyboard 2008 in two positions relative to flexible portion 2126 caused by the rotation of wheel assembly 2124. Flexible portion 2126 (shown in broken down lines) runs underneath keyboard 2008. Thus, rotating wheel assembly 2124 allows moving keyboard 2008 from a vertical position (in phantom lines), which is anatomically fit, to a horizontal position for use.

The wearable computer according to the invention can be converted into a table-top configuration. FIG. 49 shows wearable computer 2000 in a tabletop configuration, with extendable portions fully extended, and sliding clasp assembly 2106 of FIG. 44C being used as support, structure to give more stability to the extendable portions. U-shaped structure 2002 is adapted to turn into a helical configuration for a table top embodiment of the wearable computer of the invention.

FIGS. 50A and 50B shows an embodiment of the principles of the invention, exemplified by shoulder holster wearable computer 2150, whose weight is distributed

62

between the right and left side of the torso and shoulders as well as the back, by cord 2153, which runs continuously from right to left side. Cord 2153 has arms 2152 and 2154, with keyboard 2008 and display 2010 disposed at the end of each arm. FIG. 50A shows the front side of the shoulder holster computer 2150, including right and left straps 2156 and 2158 and right and left pockets 2160 and 2162, with respective slots 2164 and 2166. Flexible arm 2152 from pocket 2160 is shown uncoiled and holding keyboard 2008 and opposite flexible arm 2154 from pocket 2162 is shown uncoiled and holding display 2010. Arrows J1 and J2 represent the equally distributed tension in arms 2152 and 2154.

FIG. 50B shows the back side of holster wearable computer 2150. Straps 2168 and 2170 are secured to pockets 2160 and 2162 respectively. Strap 2168 is connected to strap 2170 by horizontal strap portion 2172, which has adjustable buckle area 2174. Wire portion 2176 runs continuously through straps 2168, 2172, and 2170 and terminates in wire portion 2178 inside pocket 2160 and terminates in wire portion 2180 inside pocket 2162 at the keyboard end. Wires 2176, 2178, and 2180, and any other wire in clothing, hats, and the like, are preferably of the ribbon type, which are flexible and can be more easily stored in a rolled position. Accordingly, wire portions 2178 and 2180 have preferably rolled-up portions 2182 and 2184, which can be extended or rolled back for fitting user of different sizes. Wire 2176 also has a rolled-up portion 2186 in adjustable buckle area 2174, for adjusting size. It is understood that to better distribute weight, a power source for example can be housed in the back in the adjustable buckle area 2174. This allows distribution of the weight to a different anatomic area, which is the back, although it is understood that the weight can also be distributed to the waist area, with the power source being clipped to a belt. Remaining parts and structure of wearable computer 2150 will be described in FIG. 50C.

FIG. 50C shows a schematic illustration of shoulder holster computer 2150. Wire portion 2180 terminates inside pocket 2162 in flexible coiled gooseneck portion 2188 with keyboard 2008 in its end. Wire portion 2178 terminates inside pocket 2160 at electrical connector 2190, which is removably connected with connector 2192 of computer housing 2030. Flexible gooseneck portion 2194 terminates distally at display 2010, and terminates proximally in wire portion 2198 in supporting plate 2196 inside pocket 2160. Wire portion 2198 terminates in the upper end in flexible gooseneck portion 2194 secured to plate 2196. The opposite end of wire portion 2198 terminates in electrical connection 2200, which is removably connected to connector 2202 of computer housing 2030. Supporting plate 2160 is attached to one of the walls of pocket 2160, and is preferably made of metal or hard plastic, and adapted to support about 650 grams of weight in a stable position. Pockets 2160 and 2162 and flexible gooseneck portions 2188 and 2194 in FIG. 45C are substantially identical to each other such that description of features of the display side herein applies to the keyboard side as well.

FIG. 50D is a cut way side view of pocket 2162. Flexible and extendable portion 2188, such as a metallic gooseneck, is in its original coiled position, preferably as a spiral for easy uncoiling and stability during use while remaining compact when stored in pocket 2162. Keyboard 2008 is shown in phantom lines on top of spiral extendable portion 2188, allowing compact storage, with extendable portion 2188 being secured to plate 2160. The description of features of the pocket 2162 herein applies to pocket 2160 as well. FIG. 50E is a cut way front view of pocket 2162,

showing keyboard **2008** resting on top of flexible extendable portion **2188**, with portion **2188** resting against plate **2160**.

Keyboard **2008** is preferably a thin membrane-type keyboard, and of dimensions that allows fit with the anatomy of the upper body. The preferred weight for the keyboard and display are such that they do not activate pain fibers, as in accordance to previous descriptions. Preferred maximum dimensions for a non-foldable keyboard are 18 cm×11 cm×1.5 cm, more preferably 16 cm×10 cm×1.0 cm, and most preferably 15 cm×9 cm×0.7 cm. Keyboard **2008** can have any number of keys, but preferably has from about 50 keys to about 84 keys. Adaptations can be made for keys with characters of other languages. The invention preferably uses a keyboard designed to be used with two hands, however, smaller keyboards, QWERTY-type keyboards, and non-QWERTY type keyboards can be used. Use of a foldable keyboard is also contemplated. Keyboard **2008** may have numerical keys adapted to dial a number for phone communication. Keyboard **2008** may also include a speaker, as well as electronics and wireless transmitters/receivers for wireless communications (including cellular telephone, radio, satellite, and internet communication). The components for wireless transmission can be also housed in housing **2030**.

Display **2010** is preferably an active-matrix LCD display, and is adapted to have dimensions and weight similar to keyboard **2008**. Keyboard **2008** and display **2010** can be permanently secured or removably secured to inverted U-shape structure **2001**. Preferred maximum dimensions for display **2010** are 16 cm×10 cm×0.9 cm, more preferably 15 cm×9.0 cm×0.6 cm, and most preferably 14 cm×8.0 cm×0.5 cm. Preferably, display **2010** has the same dimensions as keyboard **2008**. Keyboard **2008** can be replaced by a video game control system—for example—with the images of the video game being displayed in display **2010**. Keyboard **2008** and display **2010** can also be wireless and communicate with other components of the wearable computer via Bluetooth communications protocols, for example. Keyboard **2008** and display **2010** can also be foldable. It is understood that connection between the various components of the wearable computer of the invention can be wired or wireless. Display **2010** can also have a camera for video- and photo-taking or a web-cam for transmission of images over the internet and by video telephone.

A foldable keyboard integrated with a cellular phone (or any mobile phone, cordless phone, and satellite phone) can be used as part of the wearable computer of the invention. In this embodiment, keyboard **2008** can be foldable and has a transceiver for transmitting voice and/or data. FIG. **51** shows foldable keyboard-telephone assembly **2200**, comprising keyboard body **2202**, numerical keypad **2204** coupled to a transceiver **2206**, and a plurality of flexible printed circuits **2208**. Keyboard body **2202** has a plurality of keys **2214**, segmented into a plurality of blocks **2216**, so that the blocks can be folded into stacks. Flexible printed circuit **2208** connects with display **2210** in the keyboard body **2202**. Numerical keypad **2204**, coupled to transceiver **2206** has display **2210** positioned adjacent to and above keypad **2204**, with keypad **2204** being disposed at the end of keyboard body **2202**, and being used for telephone communications. When the blocks are in the folded position, numerical keypad **2204** is the outer surface of foldable keyboard **2200**. Flexible circuit **2208** is connected to electrical connector **2214** through wire **2216**. Numerical phone keypad **2204** communicates wirelessly through transceiver **2206**. FIG.

51A shows the foldable keyboard assembly in the folded position, with the keypad **2204** disposed at the front of the assembly **2200**.

A variety of input devices can be incorporated into the wearable computer of the invention. For example, during professional use, a bar code reader, RF tag reader, and the like can be used, allowing increased productivity with immediate computing and analysis of data captured during use.

Although, an illustrative example of the inverted U-shape and shoulder holster wearable computer has been described herein, it is understood that other configurations and other parts of the body can be used to support the computer by using a chest strap, a back strap, arm strap, and a belt around the waist, etc. without departing from the scope of the invention.

It is understood that the wearable computer of the invention can be implemented using two parts, by integrating the components from housing **2030** into keyboard **2008** and display **2010**. For example, hard drive, CMOS, CPU, and RAM can be integrated in the keyboard module, while sound card, video card, network card, and power source may be integrated into the display module in the opposite side. A removable module housing, for example, a DVD player/writer can also be used and removably connected to keyboard module to expand the number of available electronic components.

FIG. **52** shows wearable CD player **2230**, comprising inverted U-shape structure **2260** that includes extendable portion **2232**, disposed adjacent to CD player **2234**, and a second, portion **2236**. Preferably, portion **2236** is substantially cylindrical in cross-section. Portion **2236** is preferably non-extendable and terminates at arm **2244**, which in turn terminates at housing **2238**, which contains a power source, such as battery **2240**. Extendable portion **2232** has an accordion configuration, which remains in a compressed position by stop assembly **2242**. Extendable accordion tube **223** is preferably flexible and may be extended from the compressed position for handling CD player **2234** by lifting arm **2044** of stop assembly **2242**.

Portion **2236** includes pouches **2246** and **2248** for housing electrical jacks **2250** and **2252**, and ear buds **2254** and **2256**. CD player **2234** includes CD area **2234a** and flash card area **2258a**, for receiving flash card **2258** or any other memory storage medium. Wire **2262** is disposed on or within structure **2260** and connects CD player **2234** with power source **2240**.

FIG. **53** shows a wearable DVD player according to the invention. Wearable DVD player **2270** is worn by user **2272** and comprises inverted U-shape structure **2280**. Inverted U-shape structure (which, as in other wearable device according to the invention and described herein, can be of various shapes, provided that it has at least two arms disposed on either side of the user's neck) includes arms **2282** and **2284** having extendable portions **2274** and **2276**. Portions **2274** and **2276** are connected by central part **2278**, which is preferably non-extendable. The remaining portions of structure **2280** are essentially similar to the embodiment of FIG. **41**. Arm **2284** is connected to display **2288** (or any suitable screen) and arm **2282** is connected to DVD player **2286** (or any other disc player or memory card player), with player **2286** being further connected by cable **2292** to power source **2290** held preferably at the waist level.

FIG. **54** shows detachable wearable telephone **2300**, illustrated as a slim type phone **2306**. Wearable telephone **2300** comprises an inverted U-shape structure **2294** that includes arms **2296** and **2298**, with arm **2296** having extendable

portion 2302 disposed adjacent to a mechanical holder 2304. Mechanical holder 2304 preferably has a claw configuration for removably retaining phone 2306, such as a cellular telephone or cordless telephone. Tooth 2308 of claw 2304 slides on top of wheel assembly 2310 of cellular phone 2306 for securing phone 2306 to structure 2294. Speaker phone 2312 is disposed adjacent to holder 2304. Microphone 2314 is disposed diametrically opposed to speaker phone 2312, providing an ideal fit with the anatomy of the body for hearing and voice when using wearable telephone 2300 as seen in FIGS. 57A and 57B.

Wheel assembly 2310 is in electrical contact with a circuit of phone 2306 through wire 2322. Holder 2304 is electrically connected to housing 2316 through wire 2318. Housing, 2316 houses power source 2314 and electrical pads 2320, allowing battery 2314 to provide power to phone 2306. Although the illustration shows a detachable telephone, it is understood that a telephone permanently fixed into the system is also contemplated. In such an embodiment, phone 2306 is affixed permanently to holder 2304, and inverted U-shape telephone 2294 works as a hand set. It is stored in a cradle for recharging (not shown), with electrical pads 2320 being adapted to contact pads in the cradle for recharging telephone 2306. Telephone 2306 can be a conventional cordless telephone or a cellular telephone. It will be understood that holder 2304 can have a standard electrical connector for connecting, preferably by cable, with standard connector of phone 2306, thereby closing a circuit and providing power from battery 2314 to phone 2306. Therefore, any standard phone can benefit from the extra battery provided by structure 2294.

FIG. 54A shows the detachable phone of FIG. 54, with inverted U-shape structure 2326 having no wiring and functioning as a support structure only, without a power source and holder 2324 having no electrical wiring and working as a mechanical holder. Other features, including extendable portion of structure 2326, are essentially similar to embodiment of FIG. 54.

FIG. 54B shows a detachable phone 2338, which includes inverted U-shape structure 2340 comprised entirely of an accordion configuration, and shown in its compressed state, thereby being compact and allowing for easy storage. The dimensions of fully compressed structure 2340 are similar to or slightly larger than dimensions of phone 2306.

FIG. 55A shows inverted U-shape support structure 2350, comprising extendable portion 2342 with stop assembly 2360. Portion 2342 terminates at holder 2344, with holder 2344 preferably having cavity 2346 and moveable claws 2348 for retaining an electronic package such as a cellular phone, digital music player, digital video player and the like. Structure 2350 has pocket 2352 disposed adjacent to extendable portion 2342, preferably for storing ear bud 2358. Structure 2350 terminates at its opposite end in housing 2354 for storing an extra battery 2356. In this embodiment, structure 2350 does not have electrical wiring or electrical connectors. Holder 2344 preferably has a spring loaded assembly to allowing easier release of the electronic package removably retained by claws 2348. Referring to FIG. 55B, holder 2344 is preferably positioned at a 45 degree angle in relation to the shoulder plane, providing an anatomic fit between microphone 2366 and the user's mouth (not shown), with microphone 2366 optimally receiving sound from the mouth. It will be understood that holder 2344 can have hinge 2362 for changing the relative angle of supporting plate 2370, as shown in FIG. 55B. When the user wants to dial, stop assembly 2360 from FIG. 55 is released and portion 2342 extended, placing holder 2344 in line with the

user's eyes. It is understood that adjustably extendable portion can function as a retractable, including spring loaded, which retracts to resting (compact) position after use. For example, after using the dial pad to dial a phone number, the extendable portion returns to its compact position.

FIG. 55C shows an embodiment of the inverted U-shape structure of FIG. 55, but without an extendable portion. In this embodiment, holder 2344 has extendable cord 2345 that terminates in plate 2347. Plate 2347 has a means for being removably connected to an electronics package. Such means could include Velcro, a clip, adhesive tape, etc. Extendable cord 2345 can include a spring loaded spool assembly 2351. Alternatively, cord 2345 can be comprised of a non spring loaded retractable coiled cord. When using a retractable coiled cord with no spring mechanism for retaining cord 2345 in place, as shown in FIG. 55D, holder 2344 preferably has arms 2353 for retaining the electronics package, a spring (not shown), and release button (not shown). Any electronics package, including the ones described in FIG. 58, can be secured to plate 2347. Alternatively, arm 2372, terminating in holder 2344, may have an increased length to allow viewing of holder 2344 and for example dialing a phone or viewing a video in a digital video player. Opposite arm 2374 may also be of increased length to match dimensions and provide balance and similar tension in both arms. In this embodiment, holder 2344 does not require an extendable cord or plate 2347.

FIG. 56 shows a C-shape tubular support structure 2380 worn by user 2382 (shown in phantom lines). It includes extendable portion 2384, which terminates on the right side in a non-extendable portion 2386, and on the left side terminating in non-extendable portion 2388. Case 2390 is adapted to receive electronic package 2400, such as a cellular telephone, and is disposed on portion 2386. Case 2390 is preferably foldable, and positioned preferably at a 45 degree angle in relation to the shoulder plane. Case 2390 has opening 2398 for receiving phone 2400. Case 2390 further includes opening 2402 for receiving plug 2396, which releasably connects with ear bud connector 2410 in phone 2400. Case 2390 further includes opening 2404 for receiving antenna 2412. Wire 2392 is disposed on or inside portion 2386, terminating in ear bud 2394, shown on the ear of the user, while the opposite end of wire 2392 terminates in electrical plug 2396, which is preferably disposed inside case 2390. Right portion 2386 preferably has pocket 2414 for storing ear bud 2394, and left portion 2388 preferably has storage area 2406 for storing an extra battery 2408.

FIG. 56A shows a modified embodiment of the structure of FIG. 56, worn by user 2382 (shown in phantom lines). Structure 2420 has portions 2422 and 2424 removably connected by a mechanical connector 2426 preferably using female-male assembly. Portion 2422, illustrated as the left portion preferably extends around an arc at least 180 degrees, while portion 2424 is preferably straight and measures no more than 15 cm in length, when fully unfolded. Portion 2424 includes case 2390, shown in a folded position and retaining phone 2400. On the opposite side of case 2390 portion 2424 has wheel assembly 2426 and clasp 2428 for securing portion 2424 to a belt for example, allowing case 2390 to function as a shoulder supported structure or a waist supported structure. It is understood that a non-foldable case, preferably rectangular in shape, for retaining essentially rectangular phones, can also be used as a substitute for foldable case 2390.

FIG. 57A and FIG. 57B shows the embodiments of FIGS. 54 to 56A, and more specifically embodiments of FIGS. 56

67

and 56A, when worn by a user. FIG. 57A shows user 2432 wearing wearable telephone 2340, comprising a C-shape structure that includes extendable portion 2344, which is shown in a compressed position and a case retaining an electronics package 2346, illustrated as a foldable phone. Case and phone 2346 are anatomically positioned on shoulder 2348, adjacent to mouth 2352 and ear 2354. Opposite arm 2356 terminates in housing 2358, storing extra battery and/or ear buds, thereby equilibrating tension in the right and left portions. FIG. 57B shows case and phone 2346 of FIG. 57A in the unfolded position at 45 degree angle, when worn by a user. Microphone 2360 of phone 2346 is positioned in anatomical proximity for receiving sound from the mouth 2352 while speaker 2362 is in an optimal anatomical position relative to ear 2354. An ear bud (not shown) requires only a short cable due to the anatomical fit. FIG. 57C shows a life-like view of wearable telephone 2340 when worn by a user, with the phone 2346 (NEED correct number in figure to point to phone) at an angle for optimal anatomic fit with hearing and voice while the hands are free.

It is understood that a variety of electronic devices may be removably or permanently mounted as a anatomically fit wearable electronic article in accordance with the teachings of this invention. FIG. 58 shows a plurality of electronic devices that can permanently affixed to wearable support structure 2380 as one physical unit, or can be removably connected with support structure 2380, with the aim to achieve the anatomic criteria described herein. Structure 2380 includes pockets 2409 and 2411 for housing electrical connectors, right arm 2401 and left arm 2400. Right arm 2401 has extendable portion 2403 and flexible portion 2405. Left arm 2400 terminates at housing 2395. Flexible portion 2405 terminates at holder 2402, which preferably is removably connected with electronic devices. Alternatively, holder 2402 may be permanently connected with electronic devices. Illustrated electronic devices include portable video game 2382, music player 2384, GPS 2386, video player 2388, digital book 2390, personal digital assistant (PDA) 2392, monitoring device 2394 (including devices for monitoring any biological parameter of the body), communication device 2396, imaging device 2397, and sound device 2399. Preferably, electronic devices are connected to structure 2380, and further electrically connected to housing 2395, located in opposite arm 2400, which houses power source 2398. Alternatively, electronic devices are only mechanically secured to structure 2400 by mechanical holder 2402. Electronic devices have means to connect to holder 2402, preferably using a male-female assembly with electronic devices or by using any of the other embodiments of the present invention with structures for holding electronic devices.

As used in connection with this figure, and elsewhere in this application, the term "video player" includes, but is not limited to, conventional televisions, digital video players, digital broadcast televisions, and the like. The term "music player" includes cassette players, CD players, and, preferably, digital music players. The term "PDA" includes any hand-held computer. "Monitoring device" includes any medical device such as a glucose monitoring device. "Communication device" includes any radio, telephone, wireless receiver for internet content, wireless receiver for satellite signal, and any wireless transceiver, wireless receiver, wireless transmitter, two-way radio, and other communications device with or without imaging. "Imaging device" includes any video camera, photo camera, digital, binoculars, and the like, "Sound device" includes conventional microphone, wireless microphone, sound recorder, and the like.

68

Housing 2395 can retain a single power source or a combination of electronics and power source. By way of illustration, housing 2395 can retain in a permanent or releasable manner a wireless transmitter. It will be understood that holder 2402 can be replaced by plate 2406 (shown in phantom lines) for retaining the electronic devices, using Velcro, clips, or other retention means. Structure 2380 can further include pockets 2411 and 2409 for storing ear bud assemblies and a housing for housing a power source (not shown). It will be understood that a combination of electronic and electrical articles can be used. Many other uses and applications will become apparent to one of ordinary skill in the art. For example, the electronic device can be PDA 2392 and housing 2395 can house a pedometer which is electrically connected with PDA 2392. The user can exercise with structure 2380 around the shoulder and neck, and then information from pedometer or exercise monitoring device in housing 2395 is captured and fed into PDA 2392, adapted with software to provide feed back information to the user in real time. For instance, if PDA 2392 detects a problem with the exercise routine, the PDA can alert the user, and can provided an image of the steps needed to correct the problem. The user then can extend the extendable portion and view the display of the PDA and see step by step how to perform the exercise routine. The user can keep the arm extended during the whole exercise and view the steps while exercising. A voice system can also be used and tell the user to change the step or exercise routine. If exercising outside, the PDA or housing 2395 can have a wireless receiver for receiving information such as the weather conditions or even a message. Housing 2395 can include controls and buttons beside power source, while the opposite arm terminates in a television. Housing 2395 can include a wireless receiver for images and video conferencing, with the opposite arm holding a display and camera.

FIG. 59 shows wearable video game 2420 comprising inverted U-shape structure 2430, which in turn comprises right arms 2422 and left arm 2424, connected by central portion 2426. Left arm 2424 has extendable portion 2428 and flexible portion 2430. Flexible portion 2430 has electrical connector 2432 and terminates in mechanical male holder 2434. Electrical connector 2432 is removably connected to cable 2452 of game control 2454. Right arm 2422 has extendable portion 2436, and flexible portion 2438. Flexible portion 2438 has electrical connectors 2440 and 2442. Connector 2440 is disposed at the end of portion 2438 jointly with mechanical holder 2444, and is removably connected to display 2446. Electrical connector 2442 is preferably disposed at the right side of portion 2438 and is removably connected to cable 2448 of electronic box 2450. Wire 2426 is disposed on or within structure 2430, and connects game control 2454 via cable 2452 and connector 2432 to electrical connector 2442, with said connector 2442 being connected to electronic box 2450. A wire is disposed on or within portion 2438, and connects display 2446 to electrical connector 2442. Electrical connector 2442 connects both display 2446 and game control 2454 to electronic box 2450 via cable 2448 for operation of the system and power supply. Box 2450 preferably includes central processing unit/co-processor 2460, disc drive 2462 (or any drive or system to read a memory medium), and memory area 2464, in addition to a power source 2466. Structure 2430 includes pockets 2468 and 2470 for separate ear buds, or alternatively one jack 2472 for removably connecting an ear bud assembly. Single jack 2472 is included to allow the use of prior art ear bud assemblies which have a single plug for two ear buds.

It is understood that any wearable article of the present invention can have one single jack, as provided by devices of prior art, in order to allow use of ear bud assemblies of the prior art in the electronic wearable articles of the present invention.

FIG. 60 is a modified embodiment of the video game of FIG. 59 and includes structure 2430, having only one electrical connector 2474 in right arm 2476, which is removably connected to display 2478. Structure 2430 also has electrical connector 2480 in left arm 2482. Connector 2480 is removably connected to game controller 2484. In this embodiment the electronic box is eliminated, and the electronics and power source are distributed evenly between controller 2484 and display 2478 so that each has a similar weight. Display 2478 preferably houses power source 2486, and controller 2484, preferably houses disc reader 2488, as well CPU/co-processor 2490, memory and other circuits (not shown). Controller 2484 receives and reads disc 2490, being operationally connected with display 2478 and power source 2486 through connectors 2474 and 2480 and wire 2492.

The present invention teaches methods and devices that allow a plurality of hand held devices to be hands free. It is understood that the wearable electronic articles of the present invention can be operable from a motor vehicle 12 VDC cigarette plug accessory voltage or AC outlet through cords, and the electronic wearable articles can be charged when not in use. It is also understood that the communications between parts are preferably wired, but can also be wireless. It will also be understood that advances in the biological and electronic fields can be advantageously used in accordance to the invention. The invention teaches wearable electronic devices, which means the device is worn on the body and by being electronic requires electrical energy. Since the invention teaches such wearable electronic devices, and further considering that the human body is an electric circuit and that in order to take advantage of the electrical current in the body it is necessary to touch the body, the wearable electronics in the resting position by touching a large area of the body can be adapted to be recharge based during touching the body. Likewise the connecting arm between right and left arm by touching the body can work as an electrical circuit, and thus no wires connecting right and left arm are necessary.

FIG. 61 shows a perspective view of an embodiment of a storage cord according to the invention. Storage cord 3000 comprises sleeves 3001 and 3002, ear buds 3003 and 3004, and electronics package 3005. As described previously in connection with other embodiments, electronics package 3005 is electrically connected to ear buds 3003 and 3004. Electronics package 3005 is also optionally connected to storage cord 3000 using a retractable cord (not shown).

When electronics package 3005 is moved from its position on storage cord 3000 so that it can be brought into the user's visual axis, it remains loosely attached to storage cord 3000 with the retractable cord. This facilitates replacement of electronics package 3005 onto storage cord 3000. Preferably, movement of electronics package 3005 relative to storage cord 3000 does not result in movement of wires 3006 and 3007 or connecting ear buds 3003 and 3002 relative to storage cord 3000. That is, wires 3006 and 3007 are anchored onto storage cord 3000. Therefore, when electronics package 3005 is moved (whether or not it is attached with a retractable cord), the ear buds will not be pulled from the user's ears.

Sleeves 3001 and 3002 are preferably made of an elastomeric material, such as rubber or neoprene, so that they

can be removably, but securely attached, to the temples of a pair of eyeglasses. Openings 3008 and 3009 are sized so that they will fit snugly onto and around eyeglass temples, and preferably will be from 2 mm to 15 mm in diameter, more preferably between 5 and 12 mm. In one preferred embodiment, storage cord 3000 will be attached to a pair of eyeglasses. Alternatively, as will be described in more detail below, openings 3008 and 3009 can be attached to temple-like appendages located on other wearable articles, such as hats, or other objects, such as walls, or airline food trays.

FIG. 62 shows storage cord 3000 of FIG. 61 as it is about to be worn by user 3010. User 3010 is wearing eyeglasses 3011, which have temple 3012. Storage cord 3000 is positioned so that opening 3008 of sleeve 3002 is poised to slip over the end of temple 3012.

FIG. 63 shows storage cord 3000 of FIG. 61 being worn and used by user 3010. Sleeve 3002 has been attached to temple 3012, holding storage cord 3000 in place behind the head of user 3010. Ear bud 3004 has been positioned over ear 3013, allowing user 3010 to hear sound transmitted from electronics package 3005.

FIG. 64 shows a planar view of a storage cord according to the invention. Storage cord 3020 has sleeves 3021 and 3022, and ear buds 3023 and 3024. Electronics package 3025 (shown in this embodiment as an MP3 or other digital recording format player) is releasably attached to storage cord 3020. The attachment is both mechanical and electrical. The mechanical attachment means in this embodiment is VELCRO (not shown), which is positioned on storage cord 3020 underneath electronics package 3025. Electronics package 3025 is further mechanically and releasably attached to storage cord 3020 with U-shaped attachment frame 3026.

Attachment frame 3026 is made of hard material, preferably a hard plastic, and is sized so that electronics package 3025 can slip inside of it, with the top edges of attachment frame 3026 slightly overlapping the edges of electronics package 3025 and holding it in place by a friction fit. Electronics package 3025 is electrically attached to storage cord 3020 by means of a retractable cord (not shown). The retractable cord is held in pocket 3027, preferably on a spool (not shown). Ear buds 3023 and 3024 are electrically connected to electronics package 3025 using wires (not shown) which converge inside pocket 3027.

FIG. 65 shows a perspective view of another embodiment of a storage cord according to the invention. Storage cord 3030 comprises sleeves 3031 and 3032, ear buds 3033 and 3034, and electronics package 3035. Storage cord 3030 further comprises storage pockets 3036 and 3037, which are used for storing ear buds 3033 and 3034. It will be understood that sleeves 3031 and 3032 need not be made of the same material as main body 3038 of storage cord 3030, though they can be. For example, main body 3038 might be made of leather, while sleeves 3031 and 3032 could be made of neoprene.

FIG. 66 shows a perspective view of another embodiment of a storage cord according to the invention. In this embodiment, storage cord 3040 is made of two materials. Sleeves 3041 and 3042 are made of an elastomeric material, such as neoprene or rubber. Main body 3043 is made of metal, which gives storage cord 3040 a more formal appearance, making it suitable for use while wearing formal attire. Ear buds 3044 and 3045—which are electrically connected with electronics package 3048—are retained in spools 3046 and 3047, which are permanently attached to storage cord 3040, preferably partially on sleeves 3041 and 3042 and partially on main body 3043. It will be understood that in this embodiment, as

in other embodiments, the ear buds may be connected to the storage cord with articulated arms, rather than wires.

FIG. 67 shows a perspective view of another embodiment of a storage cord according to the invention. Like the embodiment of FIG. 66, storage cord 3050 is made of two materials. Sleeves 3051 and 3052—made of an elastomeric material—and main body 3053—made of metal—are joined by joining pieces 3054 and 3055. Articulated arms 3056 and 3057 are electrically connected to electronics package 3058. Ear buds 3059 and 3060 are removably, electrically connected to articulated arms 3056 and 3057. Thus, when not in use, the ear buds can be removed from the storage cord, and therefore be kept out of sight.

A specialized construction of the storage cord 3061 is shown in FIG. 68. Further details of the specialized construction includes a cord with a two layer design. The layers are formed by a thick layer 3062a of soft material (neoprene) and a thin layer of soft material 3062b. The thin layer is of a larger dimension than the thick layer. The wires are disposed between those two layers. Thick neoprene layer 3062a anchors the sliding ramp with they screws (not shown) to receive the electronic device. The second thin layer 3062b (which is longer and has the arms which when sown together form the sleeves 3063, 3064) is sown on the bottom of the first layer.

This design gives comfort, so wires or screws do not touch the body the wires and screws are located between two layers of neoprene, or any other soft material). This also allows the sleeves to be made of a thinner neoprene material (the less neoprene around the ear the better, and less activation of pain fibers) while the thick neoprene increases comfort by preventing anything hard, such as screws and wires, from touching the body. The electronics package box 3066 holding electronics is actually screwed in the thick neoprene. It is understood that a very thin layer of soft material forming the sleeves can be sandwiched between two layers of another material.

Sleeves 3063 and 3064 are made by sewing together the edges of neoprene 3062b with stitches 3065. Electronics package 3066 is secured on the portion of neoprene 3062a. Thus, stitches 3065 and electronics package 3066 are on the same side of neoprene 3062a. Therefore, when storage cord 3061 is worn by a user, both electronics package 3066 and stitches 3065 face away from the user's skin, minimizing any discomfort felt by the user.

FIG. 69 shows a portion of the storage cord of FIG. 68. Ear bud 3067 is electrically connected to electronics package 3066 by wire 3069. Ear bud 3067 is stored by pushing it partially inside hollow sleeve 3063. Microphone 3068 is connected to wire 3069, so that when ear bud 3067 is placed in the user's ear, microphone 3068 can pick up the user's voice and transmit it to electronics package 3066 (in this case, a cell phone).

FIG. 70 shows a perspective view of another embodiment of a storage cord according to the invention. In this embodiment, the electronics package (not shown) is secured in pocket 3070 of storage cord 3071. Pocket 3070 is closed by flap 3072, which is secured by buttons 3073 and 3074. Once the electronics package is placed into pocket 3070, it is electrically connected to ear buds 3075 and 3076 by wires 3077 and 3088. Wires 3077 and 3088 run from ear buds 3075 and 3076 through spool 3079, where they are electrically connected to wire 3080. Wire 3080 runs from spool 3079 through electrical connector 3081, which is connected to the electronics package. Storage cord 3071 may be connected to a pair of eyeglasses (or temple-like connectors) using sleeves 3082 and 3083.

FIG. 71 shows an embodiment of a storage cord according to the invention which is similar to the embodiment shown in FIG. 70. The difference is that storage cord 3084 is attached to a wearable article by attaching snaps 3085 and 3086 to complementary snaps on the wearable article. The wearable article might be, for instance, a hat, or a jacket. Alternatively, snaps 3085 and 3086 can be attached to complementary snaps on another article, such as airline tray, or a wall. In this embodiment, storage cord 3084 does not have sleeves for attaching to a pair of eyeglasses.

FIG. 72 shows a schematic diagram for a storage frame according to the invention. Storage frame 3090 comprises slide ramp structure 3091 and spool holder 3097. Spool 3092 is located inside spool holder 3097, and holds wire 3093. Wire 3093 terminates in connector 3094, which is adapted to connect to an electronics package (not shown). Connector 3094 can be either an electrical connector or simply a mechanical connector. Spool 3092 can also hold wires connected to ear buds.

Structure 3090 is shaped to receive an electronics package, with the top edges of the electronics package sliding under rims 3095 of the slide ramp structure 3091. Electrical connector 3094 plugs into an electronics package. Stabilization pin 3096 is adapted to fit into a hole in the electronics package, and helps stabilize the electronics package in structure 3090. In one embodiment, shown in FIG. 73A, the electronics package is electrically connected to ear buds 3099 and 3100 through spool 3092. In another embodiment, the connection is only mechanical, with sound or data being transmitted wirelessly from the electronics package.

Storage frame 3090 is attached to a storage cord according to the invention. When the user wishes to look at the electronics package, he or she can slide it out of structure 3091 and bring it within his or her sight, with wire 3093 being extended from spool 3092 to maintain contact with the electronics package. When spool 3092 retracts, it pulls the electronics package back into structure 3091.

This is illustrated in FIG. 73a, in which electronics package 3098 is electrically connected to or docked within storage frame 3090 through connector 3094. Ear buds 3099 and 3100 are connected by wires 3101 and 3102 to printed circuit board 3103. A wire from printed circuit board 3103 to spool 3092 allows ear buds 3099 and 3100 to be electrically connected to electronics package 3098, via wires 3101 and 3102, printed circuit board 3103, wire 3104, spool 3092, wire 3093 and connector 3094. Stabilization pin 3096 is inserted into cavity 3105 of electronics package 3098.

FIG. 73b shows the embodiment of FIG. 73a, except that electronics package 3098 has been pulled out of storage frame 3090. As electronics package 3098 is pulled away from storage frame 3090, wire 3193 is pulled out from spool 3092. However, because wires 3101 and 3102 are anchored by printed circuit board 3103, ear buds 3099 and 3100 are not pulled from the user's ears.

FIG. 74a shows an alternative embodiment of a storage frame according to the invention. In this embodiment, electronics package 3106 is electrically and mechanically connected to storage frame 3107 by connector 3108. Connector 3108 is connected to ear buds 3109 and 3110 via coiled wire 3113, printed circuit board 3114, and wires 3111 and 3112.

When electronics package 3106 is pulled away from storage frame 3107, as shown in FIG. 74b, coiled wire 3113 uncoils (extends). However, printed circuit board 3114 anchors wires 3111 and 3112, so that they do not pull away ear buds 3109 and 3110 from the user's ears.

When an electronics package is pulled away from a storage cord as described previously according to the invention, tension can be placed on the retractable wire connecting it to the storage cord. This means there is a risk that the retractable wire might pull the connector plug out of the electronics package. Therefore, it will be helpful to have a means for securing the connector in the electronics package.

FIGS. 75A and 75A1 show opposite sides of a connector stabilizer 3115, which is cross-shaped, and has clip 3116 for securing connector pin 3117 from a storage cord according to the invention. Arms 3118, 3119, 3120, and 3121 of stabilizer 3115 are secured to the sides of electronics package. This is illustrated in FIGS. 75B, 75B1 and 75B2, where the edge of electronics package 3122 is secured by arm 3123.

In one embodiment, the dimensions of connector stabilizer 3115 can be varied so that it can be secured to electronics packages of varying dimensions. It will be appreciated by those of skill in the art that the cross-shape of connector stabilizer 3115 is only a preferred embodiment; other shapes are also possible, with the only requirement being that the device be securable to an electronics package and be capable of securing a connection pin. FIG. 75D2 shows more details of a clip which is part of connector stabilizer 3125. Holder arms 3116a embrace connector 3126.

FIG. 75C shows electronics package 3124 attached to connector stabilizer 3125, which secures connector 3126 to electronics package 3124. Connector 3126 is attached to spool 3127 by wire 3128. Connector stabilizer 3125 prevents the tension in wire 3128 from pulling connector 3126 out of electronics package 3124.

FIG. 75D1 shows movement of connector 3126 towards arm 3116a and into engagement in FIG. 75D2. FIGS. 75D3 and 75D4 show the same movement in a top view, respectively.

The dimensions and shapes of electronic devices such as music players, telephones, GPS, and the like are different depending on the brand. This invention allows different electronic devices as well as different brands of the same electronic device to be used with the storage cord assembly. By having an electrical connector removably attached to a connector stabilizer, a plurality of connector stabilizers can be used, allowing a plurality of different electronic devices to be used with the storage cord of the present invention. Accordingly, FIGS. 75A through 75D4 show the movement of connector 3126 towards arm 3116 of connector stabilizer 3115. The connector stabilizer 3115 is sized to receive a digital music player, cell phone, GPS device, or any other electronic device. It is understood that the connector stabilizer can be permanently attached to the connector.

In this embodiment the connector stabilizer cannot be replaced, and is designed to fit a particular brand and model of a device. Thus, the storage cord can receive devices having only one particular dimension and shape. A further embodiment includes a connector stabilizer having adjustable arms, allowing therefore securing devices with different dimensions and shapes.

In another embodiment the connector, such as an electrical connector, is permanently attached to the electronic package or the electronic device. The permanent attachment prevents the connector from pulling out of the electronics package when tension is placed by the retractable cord. Therefore, in this embodiment, there is no need for the connector stabilizer. The electronic package is secured permanently to the connector which has a wire and preferably terminates in the retractable spool wire.

An alternative embodiment of a connector stabilizer is shown in FIG. 76. FIG. 76 shows spool housing 3129 and slide ramp structure 3130. Spool 3131 contains wire 3132, which is connected to connector 3133, which is shown plugged into electronics package 3134. Stabilizing loop 3135 is placed around connector 3133. Stabilizing loop 3135, shown in more detail in FIG. 76a, has a small hook 3136, which is used to hook into loop 3137 on electronics package 3134. When properly attached, stabilizing loop 3135 and loop 3137 will absorb the tension in wire 3132, preventing connector 3133 from pulling out of electronics package 3134. Other connecting assemblies are contemplated including a strap secured around the wire of the connector, the strap having a hook and loop surface that connects to a hook and loop surface on the electronic device. It will be understood that other means for stabilizing the connection between the connector and electronics package can be devised, and are within the scope of this invention.

FIG. 77 shows an anatomically correctly shaped telephone according to another aspect of the invention. Telephone 3138 can be either a cellular phone or an ordinary cordless phone. Body 3139 is curved, so that it can conform to the shape of a user's head or body. Display 3140 and keypad 3141 are located on the outer curved surface of telephone 3138.

Typically, an anatomically fit device, with no pressure activating pain receptors will have the following diameters: 50 cm to 80 cm for head, and preferably 55 to 75 cm, and most preferably 60 to 70 cm for diameter of the head, depending on age. The preferred diameter for an anatomically fit neck device is 30 to 50 cm, and preferably 35 to 45.

The human body, such as head and neck, are not perfectly round, thus an alternative embodiment for an anatomically fit device includes a dual shape surface, in which the central portion is essentially flat and the side portions are curved, to conform to the body portions.

As shown in FIG. 78, telephone 3138 can be slipped into case 3142, as shown by arrow 3143. Case 3142 has electrical connector 3144 located at one end. As telephone 3138 is inserted into case 3142, electrical connector 3144 is inserted into female electrical connector 3145. Case 3142 may be attached to a storage cord according to the previously described invention. In that case, electrical connector 3144 can be electrically connected to other accessories, such as ear buds.

It will be understood that any electronic device, including but not limited to telephones, cameras, and music players, can be manufactured in an anatomically correct shape (i.e. shaped to fit the body).

FIG. 79A shows a perspective view of a portion of storage cord according to the invention. Curved digital music player 3146, with display 3147 and controls 3148, is removably attached to storage cord 3149 using structure 31150 and spool holder 3151. Spool holder 3151 can have the same internal structure as described in connection with FIG. 72.

FIGS. 79B and 79C are a side view and a top view respectively of the storage cord of FIG. 79A, showing storage cord 3149, curved digital music player 3146, structure 3150, and spool holder 3151. Digital music player 3146 can be electrically connected to ear buds 3152 and 3153 through the electrical connections (not shown) in spool holder 3151. Storage cord 3149 can be removably attached to a pair of eyeglasses, for example, using sleeves 3154 and 3155.

FIGS. 80A, 80B, and 80C show a perspective view, a side view, and a top view respectively, of another storage cord according to the invention. In this embodiment, curved

telephone **3156** is secured on storage cord **3157**, using structure **3158** and spool holder **3159**. Sleeves **3160** and **3161** may be used to secure storage cord **3157** to a pair of eyeglasses (not shown) or other wearable article or object. Curved telephone **3156** may be electrically connected to ear buds **3162** and **3163** via wires **3164** and **3165**, using spools, printed circuit boards, etc. (not shown). Microphone **3166** is mechanically and electrically connected to wire **3165**.

FIGS. **81A**, **81B**, and **81C** shows another embodiment of a connection stabilizer according to invention. While similar to the embodiment shown in FIGS. **75A-C**, connection stabilizer **3167** comprises a series of arms **3168**, **3169**, **3170**, **3171**, and **3172** which are used to wrap around electronics package **3173**, as shown in FIG. **81a**. Electrical connector **3174** is secured to arm **3172**, and therefore held in place when electronics package **3173** is extended using wire **3175**, as shown in FIG. **81C**.

FIG. **82** shows a side view of another embodiment of an anatomically fit electronics package according to the invention. In this embodiment, electronics package **3176** comprises separate sections **3177**, **3178**, **3179**, and **3180**, which are hinged together. The embodiment includes an electronic package which is preferably flexible and includes articulated hardware, flexible circuits, and flexible housing. In FIG. **83**, electronics package **3176** is "bent," with sections **3177**, **3178**, **3179**, and **3180** hinging apart to create a curved-like, anatomically fit profile.

FIGS. **84A**, **84B**, **84C** and **84D** show an anatomically fit, flip-style digital music player. Digital music player **3183** comprises sections **3184** and **3185**, which are connected by hinge **3186**. Display screen **3181** is found on section **3184**, and control mechanism **3182** is found on section **3185**. Sections **3184** and **3185** may be pivoted around hinge **3186** to provide a compact electronics package.

FIGS. **85A**, **85B** and **85C** show another embodiment of a storage cord according to the invention. In this embodiment, the storage cord is secured to the user by means of clip **3187**. The clip has preferably ear buds and a housing for a retractable cord spool (not shown), and holds a digital music player **3187a** on a pad **3187h** by arms **3187c**, **3187d**, **3187e**.

FIGS. **86A** to **E** show a variation on the storage cord of FIG. **85**, where the electronics package is secured to the storage cord with clamps **3187a** having pads **3187b**. The clamps can be adjusted to fit different sized electronics packages. It will be understood that other means for securing the electronics package to the storage cord may also be used as shown in FIGS. **7A-F** (electronics device under three biased hooks or arms **3187c**), **88A-C** (electronics device under elastic hands **3187d**), and **89A-C** (electronics device under elastic net pouch **3187e**). A microphone is electrically and mechanically integrated with wire for the ear bud.

FIG. **90** shows a perspective view of another embodiment of a storage cord according to the invention. In this embodiment, sleeve **3188** of storage cord **3189** is attached to securing means **3190**, which in this case is attached to headband **3191**. Securing means **3190**, is illustrated as a rod like structure, and can also include a snap-on button, a VELCRO strip, shaped like the end of an eyeglass temple, and may be either permanently or removably attached to headband **3191**. This embodiment is shown in connected form in FIG. **91**.

FIGS. **91A** and **9113** show top view and a side view, respectively, of an attachable clip for use with a storage cord of the invention. Attachment appendage **3192** is connected to dome **3193**, which can optionally rotate around clip **3195**, as shown by arrow **3194**. Once clip **3195** has been attached to a wearable article, the sleeves of a storage cord according

to the invention, may be attached to attachment appendage **3192**, securing the storage cord to the user. Attachment appendage **3192** can also be extendable, as shown in FIGS. **92A** and **B**, respectively. Attachment appendage **3192** may also include a snap-on button, a VELCRO surface, and other anchoring means at its free end for attaching to complementary anchoring means of a storage cord. The clip may then be attached to a wearable article, such as headband **3196**, as shown in FIG. **93**. The embodiment further includes a kit containing at least one clip and one storage cord.

By rotating the attachment appendages **3197** and **3198** to face downwards, it would also be possible to attach storage cord **3199** so that it passed under the user's chin, rather than behind his or her neck. This is illustrated in FIG. **94**. FIG. **95** shows how clips **3200** may be attached to shirt **3201**, or other wearable article, to permit attachment of a storage cord **3202** according to the invention.

FIGS. **96A** and **B** show a hair band for use with a storage cord according to the invention. Hair band **3203** has attachment appendages **3204** and **3205** at its ends. Attachment appendages **3204** and **3205** may be rotatable as illustrated by arrow **3206**. FIG. **97** shows storage cord **3207** attached to head band **3208**.

It is also possible to permanently attach attachment appendages to wearable articles, so as to make them compatible with storage cords having sleeves, snap-on buttons, and the like according to the invention. This is illustrated in FIG. **98**, which shows bike helmet **3209** having attachment appendage **3210** (and a similar one, not shown, on the other side). Storage cord **3211** can then be attached for use.

Alternatively, as shown in FIG. **99**, the storage cord of the invention can be permanently affixed to a wearable article, such as helmet **3212**. The user can then pull out electronics package **3213** to look at it, and then replace it, with the assistance of the retractable cord (not shown).

FIGS. **100A-F** illustrate several views of another embodiment of a storage cord according to the invention. In this embodiment, storage cord **3214** is made of a rigid material and is shaped to fit around the users neck or shoulders (or other body part). The ear buds may either be attached using wires or arms, as shown. In these embodiments, the storage cord may be used without attachment to another wearable article.

FIGS. **101A-D** show a system for securing a rigid attachment appendage around the user's ears, which might be useful if the user is not wearing a hat or shirt. Similarly, the ends of the storage cord may be shaped to fit around a user's ears, securing the storage cord to the user. The appendage includes foldable portions to position a microphone, for example, into a particular position. The arm of the appendage can include in its free end a snap-on button, VELCRO surface, or other anchoring means, which can be attached to complimentary anchoring means in the storage cord.

FIGS. **102A** and **B** show another embodiment of a storage cord according to the invention. In this embodiment, all elements of storage cord **3215** are soft, maximizing the user's comfort. Electronics package **3216** is stored in pocket **3217**, which can be either open (as shown in the figure) or sealable (with a zipper, or button, or other sealing mechanism). Retractable spool **3218** is stored in sealed pocket **3219**, and is electronically connected with ear buds **3220** and **3221** via wires **3222** and **3223**.

FIGS. **102A** and **102B** show another embodiment of the invention comprised of ear bud cords having a dissimilar length. As shown in FIG. **102B** the exposed portion of the ear bud cords have similar length. However, FIG. **102A** shows that the total length (exposed and non-exposed por-

tions) of ear bud cord **3322** is shorter than the total length (exposed and non-exposed portions) of ear bud cord **3323**.

FIG. **102C** show another embodiment of a storage cord according to the present invention. In this embodiment, a snap-on button **3215a** is located at the end of each arm **3215b** for anchoring to complementary buttons on, for example, a wearable article. FIG. **102C** shows a cut away view of the pocket **3217**, exposing the retractable cord spool **3219a**, with the cord in an extended position and the electronics package **3216** located outside the pocket **3217**.

FIG. **103** illustrates another useful embodiment of the invention. In this embodiment, storage cord **3224** contains a releasably attached wireless device, such as a BLUETOOTH receiver **3225**, which can receive signals from nearby BLUETOOTH enabled devices **3225b**, **3225c**, such as MP3 players or telephones. BLUETOOTH receiver **3225** takes these signals and transmits them as sound to the user through the ear buds **3225a**. This allows the user to keep multiple electronic devices close by (for example in jacket pocket or briefcase) and use them simultaneously. The user can determine which device will be transmitting sound to his or her ears by manipulating a simple button **3225d** located on the receiver. In this embodiment the storage cord can include a microphone and the storage frame can include a connection (not shown) for a microphone, which is adapted to receive a complimentary connection of the BLUETOOTH receiver.

In another embodiment, shown in FIGS. **104A-D**, the wireless device represented by a BLUETOOTH receiver—or other receiver, like an AM or FM radio receiver **3225f**—can be connected to a connector on the storage cord **3225e** or be permanently affixed, said wireless device having a connector for receiving another electronics package **3225g**. Thus, a digital player, for example, can become wireless enabled by connecting with the BLUETOOTH device on the storage cord, or can have FM radio capabilities by connecting with an FM radio on the storage cord. This embodiment may include two connectors, one in the storage frame and a second one in an electronic package stored in the storage frame.

FIG. **105** illustrates how the wireless device, illustrated as a BLUETOOTH receiver **3225** on the storage cord **3224** can receive signals from multiple sources **3225h** and **3225j** and transmit sounds from those sources to the user. The BLUETOOTH device **3225** is preferably removably mounted on the storage cord and connected to a connector in the storage cord.

By having a microphone integrated with the ear bud cord of the storage cord, as seen in FIG. **105**, the invention provides a specialized new BLUETOOTH device, which does not require the housing to have a microphone. The BLUETOOTH device can be stored in the storage cord and connected by a connector as shown in FIG. **72**.

After the BLUETOOTH device is connected to the connector of the storage cord, an electrical connection between the BLUETOOTH device and the wire of the ear bud having the microphone is created. The jack of the BLUETOOTH device is adapted to receive the connector of the storage cord, said connector illustrated as an audio plug. Thus, the BLUETOOTH device of the invention has a simpler construction and lower cost by not having to include a microphone in its structure, either a built-in microphone or a microphone connected by a wire to the BLUETOOTH device.

By the storage cord having an ear bud, the BLUETOOTH device of the invention does not require a speaker. Thus, this BLUETOOTH device of the invention includes a receiver

for receiving a wireless signal (such as an audio signal) and a receiving circuit and wire that conveys the audio signal to an audio jack in the BLUETOOTH device, said audio jack being connected to the connector of the storage cord, said connector connecting with the ear bud.

Thus the BLUETOOTH device delivers sound to the ear bud. Since there is a microphone integrated with the ear bud cord, a voice signal can be conveyed back to the BLUETOOTH device, said voice signal being conveyed through a transmitting circuit and transmitter for transmitting the voice signal to another BLUETOOTH enabled device.

By not having speakers or microphone, the BLUETOOTH device includes only a housing having at least one audio connector, and said housing having a transmitter and receiver module, and the associated transmitting and receiving circuits, a power source, and other common parts such as amplifiers, antenna, and function buttons for answering calls and volume control. In addition to this embodiment, this invention teaches other new wireless communication devices in FIGS. **18** to **23C** and in FIGS. **34D** to **34O**.

FIG. **106** illustrates another embodiment of the storage cord according to the invention. In this embodiment, electronics package **3226** may be controlled using removably mounted infrared emitting remote control **3227** (similar to a television remote control) which, when not in use, may be stored on the storage cord. The infrared receiver **3227** may be located on the electronics package (as shown) or, preferably, attached as receiver **3227a** to one of the ear bud wires or as a receiver **3227b** on the storage cord. In this position, it will be easier to activate using the remote control. A storage cord for the package **3226** is retractably mounted in holder **3227c** having finger recesses **3227d** and **3227e**.

FIG. **106A** shows a user **3227f** wearing eyeglasses **3227g** connected to the storage cord **3227h** and infrared remote control **3227i** emitting a signal **3227j** for controlling the function of an electronics package. The infrared receiver **3227k** is disposed on the surface of the ear bud or speaker **3227l**. FIG. **106B** is similar to FIG. **106A**, but the infrared receiver **3227k** is located on the arm of the storage cord **3227h**.

FIG. **107** shows a similar embodiment, except that there is no retractable cord, so that the electronics package must stay on the storage cord in order to remain connected to the ear buds. This means the only practical way to control it is with the remote control. This configuration minimizes the number of parts for the storage cord.

FIGS. **108A** and **108B** show a remote control for use with the embodiments of FIGS. **106** and **107**. Because the remote control will be pointed towards the user when being used, the numbers are reversed, as shown in FIG. **108A**, from the usual pattern on the device, or being “right side up”, as shown in FIG. **108B**, when the device is pointed at the user. The invention teaches a new remote control in which the top portion of the numbers and letters (alphanumeric marks) point away from the infrared emitter, as seen in FIG. **108B**. Alternatively, IR emitter **3228** can point along an axis perpendicular to the main axis of the device, so that when it is pointed up, the IR signal will be directed back towards the user, such as in an L-shape configuration.

FIG. **109** shows a storage cord **3229** where the electronics package **3229a** is permanently affixed. A charge port **3229b** is provided to charge the electronics package.

FIG. **110** shows another embodiment. In this embodiment, the electronics package is a telephone. However, the heaviest and bulkiest parts of the phone (eg. the battery **3229d**, long range antenna **3229e**, and associated wireless communication module, such as a BLUETOOTH MODULE—not

shown) are permanently affixed to the storage cord **3229f**. The parts of the phone which must be user accessible (e.g. dial pad and display) are kept on a small, removably attached device **3229c** which communicates with the rest of the system using BLUETOOTH protocols. This is similar to the system described in connection with FIG. **39**. This assembly allows the cell phone interface with control buttons and dial pad to have credit card dimensions. Two types of transmission devices are contemplated: 1. wireless, in which the hand held device has a wireless transmitter and 2. wired, in which the hand held device has a wire connected to the storage cord.

FIG. **111** shows an embodiment in which the storage cord contains no electronics package, but instead communicates through wire **3230** with another system, for example a phone system. In this embodiment, the storage cord functions simply as a headset, and may include a microphone and speaker.

FIG. **112** shows an embodiment in which the electronics package generates a noise cancellation signal, to assist in providing the user with quiet in an otherwise noisy environment (for example on an airplane.) The signal **3232** may be transmitted to the receiver **3234** either by wires or wirelessly. The receiver includes an IR receiver and a battery power source.

FIGS. **113** and **114** show storage cords according to the invention which are connected to a hat **3236** using a series of mating buttons **3331** and **332**. The large number of buttons ensures a secure hold, and allows the hat to be adjustable in size, while maintaining a snug fit for the storage cord. This is a particularly useful configuration when the electronics package is a two-way radio, as is commonly used in hiking. In FIG. **114**, microphone **3333** allows the user to speak and have that sound transmitted via the two way radio secured to the hat **3236**. Normally, two-way radios have an upright antenna as part of the body. The specialized two-way radio of this invention includes a foldable antenna, allowing a compact system and shorter device to be comfortably stored on the back of the hat, as seen in FIG. **113**.

In FIG. **114** the antenna is seen in its unfolded and extended position. When in use the axis of the antenna is perpendicular to the axis of the housing of the radio, thus minimizing the total length of the radio system. This is contrary to two-way radios of the prior art in which the antenna is positioned on top of the radio thus increasing its overall length.

In FIG. **115**, a specialized hat **3400** is shown having two arms **3402**, **3405** anchored at ends **3406**, **3408**, respectively, so that the free ends point toward each other. A storage cord assembly **3410** is used as previously described in the various embodiments. However, on a rear side of the storage cord assembly, are located two holes spaced apart corresponding to the distance between the anchored ends **3406** and **3408** of the hat **3400**. By movement of the storage cord assembly in the direction of arrow **3412**, the storage cord assembly can be mounted on the side of the hat **3400** by the interengagement of the storage cord assembly and the arms **3402** and **3404**.

In FIG. **116**, an alternate embodiment of FIG. **115** is shown where two hook and loop fasteners **3414** are located on the side of the hat **3400** so as to cooperate with storage cord assembly **3410**. Storage cord assembly **3410** has two corresponding meeting hook and loop fasteners on its underside to engage with the hook and loop fasteners on the side of the hat.

In FIGS. **117A** and **117B**, a bicycle helmet **3416** is shown having a plurality of spaced openings **3418a**, **3418b**, **3418c**

and **3418d**. On the underside of storage cord assembly **3420** is located a clip **3422**. The arms of the clip are spaced to engage in recesses **3418b** and **3418c** by movement in the direction of arrow **3424** for engagement on the upper surface of the helmet. As previously explained, ear buds **3426** can be inserted in the ears of a user. In this embodiment the storage cord can include a rigid plate as seen in FIG. **117A**.

In FIG. **118**, a shirt **3422** is shown having two spaced apart buttons or snaps **3426**. With reference to FIG. **119**, a storage cord assembly **3428** is shown having on its underside two corresponding buttons or snaps (not shown) spaced apart equal to a distance separating the buttons **3426** in FIG. **118**. The storage cord of this embodiment has a special construction that includes two retractable cord spools, one for the ear buds and one for the electronic package. The upper arrow points upwards which is the direction of movement when pulling the ear buds. The lower arrow points downwards, showing the direction of movement when pulling the electronic device. As shown in FIG. **120**, the storage cord assembly **3428** is mounted on the shirt **3422** for use of the storage cord assembly by the user.

An image of the snap-on button assembly is seen on the lower part of the storage cord as two circles.

In an alternate embodiment as shown in FIGS. **121A** to **121E** a storage cord assembly pocket **3430** includes space for an electronics device **3432** in one pocket and includes space for two retractable cords **3434** and **3436** in an upper pocket **3438**. Ear buds **3440** are also stored in the upper pocket **3438**. The ear buds are connected by a cord to retractable cord mechanism **3436** whereas the electronics component **3422** is connected by a cord to retractable cord mechanism **3434**.

In FIG. **121A**, the electronic component **3432** and ear buds **3440** with microphone **3442** are shown in the extended position outside of the pockets **3430** and **3438**. On the rear side of the pocket package is located a pin **3444** to anchor the assembly on a shirt or other garment. As shown in FIG. **121D**, when the components are assembled in the package, an aesthetically pleasing wearable assembly is formed. As shown in FIG. **121E**, the assembly is secured on the shirt **3446** of the wearer.

In FIGS. **122A** through **122D**, a storage cord assembly **3450** is shown. On one side of the assembly is located a receiver **3452** for receipt of an electronics device **3454**, such as an MP3 player, and ear buds **3456**. On the opposite side of the assembly is a compartment **3458** for receipt of a cell phone **3460**. The two components **3454** and **3460** are located on opposite sides of the assembly **3450**. FIG. **122c** shows the cell phone **3460** mounted in the compartment and connected to a retractable cord assembly **3462**. On the opposite side of the assembly **3450** is housed the MP3 player **3454** and a retractable cord assembly **3462** for the MP3 player **3454** and a retractable cord assembly **3464** for the ear buds **3456**.

A CPU **3466** controls both the MP3 player **3454** and telephone **3460** so if, for example, a telephone call is received during playback of the MP3 player **3454**, the playback may be temporarily paused or stopped so that the telephone call may be received. It is possible that the CPU upon detecting the end of the telephone call would resume play of the MP3 player **3454**.

In FIGS. **123A** and **123**, a cell phone **3470** is shown having two connecting arms **3472**. The arms **3472** are adapted to cooperate with a storage cord assembly as previously shown and described for anchoring of a storage cord around the neck of a user and hanging of the cell phone **3470** in front of the user. Ends of arms **3472** may also include a snap-on button, VELCRO surface, and the like.

81

In FIGS. 124A through 124C and FIG. 125, a mechanism is shown to attach a storage cord assembly 3474 to the rear of a seat 3476, such as an airplane seat. Two parallel projecting arms 3478 which are foldable and retractable project from the rear of the seat 3476. Two ends of the storage cord assembly 3474 are moved in the direction of arrow 3480 to engage free end 3482 of the arms 3478. As shown in FIG. 124C, the storage cord assembly 3474 and electronics component 3484 are allowed to be suspended from the rear of the seat. Alternatively, as shown in FIG. 125, two support arms 3486 and 3488 are located on the seat 3486 at different heights. In this arrangement, the storage cord assembly 3490 having ends 3492 and 3494 are anchored on the arms 3486 and 3488.

In FIG. 126A through 126C a platform 3496 is shown having pivotal arms 3498 to engage with the free ends 3500 of a storage cord assembly 3502. The free ends 3500 are forced over the arms 3498 and held in position as shown in FIG. 1260 for locating the storage cord assembly in a particular position and location. It is possible that a recharging port 3504 and a USB connection 3506 are present in the platform 3496 to connect the storage cord assembly 3502 and its associated electronics with a large amplification system or merely for connecting a second stereo ear bud assembly by port 3508 of the storage cord assembly. Port 3508 allows a longer ear bud cord to be connected to the storage cord. This provides a user the option to use a longer ear bud cord when the storage cord is located away from the body, such as when watching a video. The free end of arms 3498 may have snap-on buttons, VELCRO surfaces, and the like for receiving complimentary anchoring means of a storage cord.

In FIGS. 127A through D, the platform 3496 is pivotally mounted on a rod 3510 by a universal connection 3512. As shown in FIGS. 127C and 127D, the platform 3496 may be pivoted to any particular location so as to fit in a desired location.

Similarly, in FIGS. 128A through 128D, the platform 3496 is again mounted on a universal joint 3512 mounted at the top of a rod 3510. However, in this embodiment, a tripod assembly 3514 supports the lower end of the rod 3510 so as to elevate the platform 3496 by the height of a tripod and collapsible rod assembly 3510.

In FIGS. 128E through 128K, the platform 3496 is supportable by a U-shaped rod 3516 mounted by its free ends 3518 on the rear end of the platform 3496. As shown in FIG. 128K, the platform can lay flat, be tilted at an angle of approximately 70° as shown in FIG. 128J or at an angle of 90° as shown in FIG. 128K. Assemblies shown in FIGS. 124 to 128K allow the storage cord to become a hands free viewing station.

In FIGS. 129A through 129C, an alternate embodiment of an anatomically fit curved telephone 3520 is shown. The curved telephone is mounted in a cradle 3522 in FIG. 129A. As shown in the top view in FIG. 129B, the phone 3520 rests in the cradle having an exposed keypad 3524 for dialing of calls. Alternately, on the reverse side of the telephone as shown in FIG. 129C, the telephone includes its own keypad 3526 and digital display 3528. At one end of the telephone is a speaker section 3530 and at the opposite end a microphone section 3532. Due to the curvature of the telephone, the telephone 3520 may be placed at the back of the neck of a wearer as shown in FIG. 130.

The speaker section 3530 and the microphone section 3532 are extendable from the midsection of the telephone by rigid cords such that when the telephone is located on the rear of the neck of the wearer, the speaker may be located

82

next to an ear and the microphone extended adjacent to the mouth of the wearer. This assembly positioning is better shown in FIG. 131. The telephone preferably includes cavities for storing the rigid cords.

It is also understood that a flat telephone could be alternatively used, and have extendable arms for securing around a body part. Preferably the telephone in a non-extended position measures between 15 and 30 cm in length.

In FIGS. 132A and 132B, a telephone 3550 is shown having a central portion 3552, a pivotally mounted arm 3554 having a microphone 3556 at its free ends and another pivotally mounted arm 3558 having a removably mounted ear phone bud 3560 connected by a retractable cord 3562. With the arms pivoted outwardly as shown in FIG. 132B, the phone is formed to rest on the back of a neck of a user. In this position, the microphone 3556 and ear bud 3560 are used for communication. However, when the arms are collapsed as shown in FIG. 132A, a second microphone 3564 and a second speaker 3566 can be used with the flat surface 3568 held against the ear of a user. Therefore, by the redundancy of the microphone and speaker, the telephone of the present invention can be used in a form to be draped over the shoulders of a user or have its arms collapsed to be used as a regular telephone.

In FIG. 133, a neck telephone 3570 is shown having a microphone 3572 at a free end of a pivotal arm 3574 and an ear piece 3576 connected by a retractable wire 3578. As shown in greater detail in FIG. 134, the horseshoe shaped rigid portion of the telephone 3570 can extend about the neck of a wearer. In an alternate embodiment as shown in FIG. 135, one end 3580 of the telephone is reduced in thickness to reduce weight and be foldable so that it is possible that the telephone may be placed inside the pocket of a wearer.

In an alternate embodiment as shown in FIGS. 136A and 136B a horseshoe shaped telephone 3582 includes a removably mounted keypad 3584 which includes a speaker and an ear clip 3586 so as to fit around the ear 3588 of a wearer and be connected to the telephone by a retractable cord 3590. By extension of the cord 3590, the keypad may be placed in front of the wearer so as to visualize the dialing of a phone number and placement around the ear 3588 of the wearer when a telephone connection is made. A microphone 3592 is located at free end of pivotal arm 3594. Keypad can be located in any position of the horseshoe shaped telephone.

In FIG. 137, a rigid horseshoe shaped support 3596 includes two removably mounted ear pieces 3598 connected by retractable cords 3600 to the rigid support 3596. The terminal end arms 3602 are pivotally mounted on the rigid support 3596 for collapsing the overall dimensions of the neck supported telephone. An electronics component package 3604, including a music device, may be mounted at a rear portion of the telephone and connected in a rigid manner or by a retractable cord for ease of operation.

In FIG. 138, a curved telephone handset 3606 is shown having a keypad 3608 and display 3610 located on one side of the handset. On an opposite side, shown in dashed lines, is a speaker 3612 and a microphone 3614. The radius of curvature of the handset accommodates the back of neck of a wearer. By positioning of the speaker and microphone on the opposite side from the keypad and display, the phone has a dual purpose use, mounted on the neck of a wearer or held by hand.

In FIG. 139, a storage cord assembly 3616 includes a music device 3618 such as an MP3 player having an FM transmitter 3620 attached thereto. The music device 3618 and the FM transmitter 3620 are removably mounted on the

storage cord assembly such that by transmission of an FM single from transmitter **3620** to an FM signal receiver **3622** affixed to the storage cord assembly, the music device **3618** may be held by the user and a signal transmitted to the FM receiver of the storage cord assembly **3622** for playback through the ear buds **3624**.

In FIG. **140**, a rigid C-shaped neck support **3626** is shown removably mounted on the neck of a wearer. A clamping assembly **3628** cooperates with an electronics component **3630** connected to the holder **3626** by a retractable cord **3622**. With the electronics component **3630** mounted in the clamping structure **3628**, audible signals may be transmitted to the retractable ear buds **3624** such that communication from the electronics device can be relayed to the wearer. For example, a global positioning satellite tracking device can verbally send directions to the wearer through the ear buds **3624** for assistance in driving directions. Alternatively, or in addition to, the electronics communication device **3630** can be a telephone which is used by the microphone **3636** and the ear buds **3634**.

In FIGS. **141** through **144**, various arrangements for mounting a structure adjacent the face of a wearer include the use of a storage cord assembly **3638** having an electronics component **3640** and ear bud **3642**. The storage cord assembly **3638** can be used to secure a headlight assembly **3644** in front of the wearer with the battery and electrical connections being stored in the electronic component **3640** in the rear of the head of the wearer. This minimizes the amount of weight located on the face of the wearer.

Similarly, in FIGS. **142** and **143** a storage cord assembly **3638** is used to locate a binocular or magnification device assembly **3646** with an electrical connection for an illuminating or magnifying force being enclosed in the electrical component **3640**. Alternatively, if the magnification device does not require a digital or electronic enhancement, a mechanically actuable magnification device can be mounted in the storage cord assembly and facilitate the movement of the magnification device **3646** out of the way of the wearer as shown in FIG. **143**.

In an alternate embodiment as shown in FIG. **134** a rigid storage cord assembly **3648** can be used to support a visual display device **3650** over the eyes of a wearer. The electronics component can be supported behind the head of a wearer **3652** with sound being transmitted to ear buds **3654** by retractable cord **3656**. A power cord **3658** can be connected to a power source **3660** for powering the electronic component **3652**. Also, a game controller **3662** can be connected to electronic component **3652** by cord **3664** or transmit a wireless signal **3666** to a receiver of the electronic component **3652**.

In FIG. **145**, a rigid support **3670** can support a video screen **3672** in front of the eyes of a wearer by pivotal connecting links **3674**. The electronics for the display on the video screen **3672** can be housed in removable electronics compartment **3676**. The electronics component **3676** can include a digital imaging processor or a global positioning satellite receiver to convey an image to the video screen **3672**. On the opposite side from the electronic component **3676** may be mounted a removably mounted cell phone **3678** which also by electrical connection may be heard through ear buds **3680**.

Another object of this invention is to provide a new and novel thermal pad for the application of cold or heat to the neck and/or head area for cooling or heating the brain.

A further object of this invention is to provide a storage cord adapted to secure and/or anchor a thermal pad which covers the neck area, and may extend to other areas of the

head, neck, and shoulders. The best place in the head to provide the largest amount of thermal energy transferred to the brain is the back of the neck—the back of the neck has a large, less insulated area than other parts of the head since there is no thick bone, such as the skull, and a thick layer of tissue called galea aponeurotica. In addition, the carotid arteries are in closer proximity with the surface of the skin in this neck area than other parts of the head.

A preferred embodiment includes a storage cord having an extended thermal pad covering the neck in which only the skin of the neck is exposed to the thermal energy and the remainder of the thermal pad facing the exterior is well insulated, preventing the warming up of the gel or ice placed inside the bag. For the purposes of illustration some figures show a mesh facing the environment in order to show the thermal pack inside the pouch. However, it is understood that any portion facing the environment includes preferably insulating material. The thermal pad container of the storage cord can also include a radiant heat-reflecting film over various portions thereof, and an insulator over the same or other portions and which together facilitate directional cooling or heating the skin area.

The thermal neck device of the present invention can work as a stand alone unit or can be anchored with a storage cord holding an electronic device. The thermal neck device or thermal neck pad of the present invention applied to the neck area promotes selective brain cooling or selective brain heating for treating hyperthermia and hypothermia, respectively. The brain, which is the most sensitive organ to thermally induced damage, can be protected by applying heat to the neck via the storage cord during hypothermia or removing heat during hyperthermia. The cooling or heating is selective since the temperature of the remaining body may not need to be changed. This is particularly important when cooling the brain for treating patients with stroke or any brain damage. The majority of the brain tissue is water and the removal or application of heat necessary to cool or heat the brain can be precisely calculated using well known formulas based on BTU (British thermal unit). A BTU is the amount of energy needed to raise the temperature of a pound of water 1 degree F., when a pound of water cools 1 degree F., it releases 1 BTU.

The thermal pad of the storage cord for therapeutic treatment of excessive heat or excessive cold in the brain preferably includes a pouch for receiving a thermal bag (or thermal packet or thermal pack) having a substantially convex surface such as a shape of a comma, banana, or circular shape, with said thermal pack being preferably in complete overlying relationship with the entire neck, said bag including an outer wall and an inner wall defining a sealed cavity to be filled with ice, gel-like material, water, solid material, and the like, for cooling or heating the skin area overlying the neck and adjacent areas to the neck and shoulders.

An exemplary brain cooling or brain heating device includes hot and cold pad or pack adapted to fit and match the neck anatomy and comprising a preferably flexible and sealed pad and a gel within said pad, said gel being comprised of a mixture of water, a freezing point depressant selected from the group consisting of propylene glycol, glycerine, and mixtures thereof associated with other compounds such as sodium polyacrylate, benzoate of soda, hydroxibenzoate, and mixtures thereof and a thickening agent. Any other cooling or heating device or chemical compounds and gels including a combination of ammonium nitrate and water can be used as cooling agent as well as heating agents such as a combination of iron powder, water,

activated carbon, vermiculite, salt and Purge natural mineral powder. In addition, an electric device, such as a Peltier device, a serpentine circulating water or fluid channel, and the like anchored or as an integral part of the storage cord can be used. In this embodiment, the electrical portions may include a small motor for moving water in a serpentine path for heating and cooling electrical parts and electronics including a microprocessor housed in the storage cord in a permanent or releasable manner, thus exemplifying other embodiments for the DEP of this invention.

FIG. 146A shows a diagrammatic view of a preferred eyeglasses thermal pack cord 3700 also referred to herein as eyeglasses cold/hot pack adapted for use with eyeglasses, and having two sleeves 3702 for anchoring to the temples of eyeglasses and a central portion 3704 that has means for holding thermal bags 3706. Any means to hold thermal bags including netting 3708 located in the central portion of the storage cord can be used. The eyeglasses storage cord illustratively has two net pouches or pockets 3708 for receiving thermal bags 3706, with a mesh like structure forming the pouch.

The mesh like structure is preferably the face of the pouch in contact with the skin while the opposite face of the pouch comprises insulating material, such as THINSULATE, a polyurethane layer, a polypropylene layer, MYLAR, and the like. The left pouch is shown having a thermal pack 3706 and the right pouch is shown empty, and about to receive a thermal pack 3706. The portion of the pouch facing the skin is made in a way to allow unobstructed transfer of thermal energy from thermal bag to the skin including minimal amount of material disposed between the bag and the skin. The pouch may further comprise no material between the bag and the skin, and in this embodiment the bag is held in the pocket by flanges in the periphery preferably with some elasticity for more stability. FIG. 146B shows a lip 3710 to grab the bag 3706. The lip 3710 prevents transfer of heat to the bag 3706 thus avoiding contact with a heat source from the hand of the user.

FIG. 147 shows in more detail a perspective view of the single cold/hot pack device 3706, represented by a device to be applied to the back of the neck, including preferably a pad having one generally convex surface 3712 and an essentially flat or slightly convex surface 3714, with said surfaces being sealed in a conventional fashion at its ends to enclose a quantity of a gel-like material 3716 which fills the pad sufficiently to enable said pad to be closely conformed to the anatomy of the back of the head and neck area.

FIG. 148 shows the specialized convex surface 3712 of the cold/hot pack 3706 of the invention and the matching surface 3718 of the back of the head and neck area. The cold/heat pack preferably includes a lip, handle or any means 3710 to facilitate grasping the pack for placement in or removal from the pocket.

The cold/heat pack device can include a pillow-like configuration which permits better molding of the surface opposite to the skin or facing the environment may include a hard part made preferably of hard rubber or plastic attached to a bag made of soft plastic with said bag containing gel and being deformable upon external pressure. The surface of the bag facing the skin may also contain an adhesive portion in its periphery for better conforming and apposing to the skin of the neck. Any suitable adhesive for skin including double sided tape can be used.

For one of the preferred embodiments, prior to use the thermal pack would be put into a freezer or other chilling device for use as a cold pad or would be put into hot water to be used as a hot pad. The thermal pad preferably com-

prises a tough flexible envelope of plastic material. The material within the thermal pad is preferably a gel which will maintain its gel-like consistency over a wide range of temperatures. There exist many gels which can be cooled to freezing and which absorb heat during warmup. There are a number of different types of such gels. Some of them freeze solid, and some are flexible even at 0 degrees F. Cold packs such as a frozen water-alcohol mixture can also be used. Alternatively, a thermal pad includes a bag having inner and outer walls lined interiorly with plastic which define a cavity to be filled with ice, or fluid such as water, through an opening in the bag. In this instance the bag is preferably sealed with a rubber material or a water-proof material.

Although flexible plastic is described as a preferred material for containing the gel, it is understood that any material or fabric can be used including vinyl, cotton, rayon, rubber, thermoplastic, synthetic polymers, mixtures of materials, and the like. The size and shape of the pad structure is adapted to fit the special anatomy of the back of the head and neck and for matching the special geometry of the anatomic area.

By using detachable thermal bags secured inside pockets, the bags can be easily replaced when said bags return to the original temperature. Therefore, in the summer time, when the bags, which were initially cold, invariably become hot as a result of the second law of thermodynamics, said bags can be easily replaced by a cold one. Accordingly, the invention includes a kit comprised of an insulating container having at least one thermal pack. The kit may also include a storage cord, and yet further include an electronic device, and furthermore can include a wearable article. The kit can include an insulating container and a box holding the other articles.

Any cooling or heating device known in the art can be used in the pad treatment device including hot or cold water flowing through tubes that are adapted to carry or deliver heat to the area. The tubes can be mounted in any head gear or the frame of eyeglasses, pumping mechanisms can be mounted in the head gear or eyeglasses for providing a continuous flow of water through the tubes. The pad can be connected to tubes which have connectors for joining to a water temperature control and circulating unit in the storage cord anchored to head gear or eyeglasses. Hot or cold liquid is circulated through tubes which are in communication with each other and which deliver or remove heat from the neck area.

Clips, elastic bands, hook and loop fasteners, and the like can be used for securing the storage cord thermal pad in position. Any of the support structures mentioned herein can be used to secure the storage cord thermal pad in position including a piece of glue. For example, the thermal pack can include a clip like mechanism to be anchored to a storage cord or the thermal pack can be secured to the temples of the frame of eyeglasses.

Head mounted gear including helmets and caps can include an extension covering the neck, said extension having a pocket for receiving a thermal bag of the invention. The extension having thermal pouches can be permanently attached to the head mounted gear or be releasably connected to said head mounted gear. The extension can include cooling or heating devices for delivering or removing heat from the neck area. The head mounted gear can also be adapted to receive a thermal pack without an extension. In this embodiment the head mounted gear has a recess or cavity which can receive the thermal bags. A helmet with such extension or cavity can be useful during sports. The thermal bag is secured in the cavity or extension with

pockets at the beginning of the physical activity. During a break the thermal bag is removed and then replaced with a new one having the desired temperature for example to reduce the temperature in the brain of a football player in the summer, or for warming up the brain of a skier during a winter competition.

An alternative embodiment includes a thermal pad anchored to the storage cord for supplying water to evaporatively cool the neck area. In this instance the cold feeling is generated by evaporative cooling in the neck area directly on the skin or by a piece of material which retains water.

Any cooling or heating device can be used to cool or heat the neck area for selective brain cooling or brain heating, preferably using a moldable device that conforms to the anatomy of the region, with directional temperature control properties for cooling or heating the skin. Any of the devices for heating or overheating or for cooling, including electrical, chips, semiconductor, polymers, and the like known in the art as well as described in U.S. Pat. No. 6,544,193, herein incorporated in its entirety by reference, can be adapted in support structures connected to or being part of a storage cord for positioning at the neck area, and used for cooling or heating the brain.

The present invention provides a moldable thermal pad or thermal pack in a packaging arrangement that can provide surfaces of differing thermal conductivities and heat reflecting properties so as to prolong the useful cooling/heating time thereof. The construction and materials of the thermal pad or thermal pack permits the molding of its shape and the retention thereof to the neck and back of the head site on the skin between the eye and nose. The materials disclosed herein can remain flexible for temperatures in the range of -10° C. to 140° C.

FIG. 149 shows a side view of an eyeglasses thermal pack storage cord 3720 of this invention being worn and used by user 3722. Sleeve 3724 has been attached to temple 3726, holding storage cord 3720 with thermal pack 3728 located in apposition to the skin of the back of the head and neck 3718, and preferably positioned in the neck area. The embodiment includes an insulating material 3730 facing the environment and covering the thermal bag, said insulating material can include an armored material, which can protect the neck of military and law enforcement personnel against being shot while keeping adequate brain temperature for mental and physical performance.

FIG. 150 shows an alternative embodiment of FIG. 149 including an additional pouch or pocket 3732 adjacent to the thermal pack pouch. The thermal pack 3734 is shown including a bag with gel 3736 with said bag having two surfaces, one facing the skin and positioned at the back of the head area, and a second surface facing the additional pocket. This additional pocket can include any of the embodiments of the invention, such as for retaining an electronic device 3738 and may include other parts such as spools, wires, and the like.

FIG. 151 shows a side view of an alternative embodiment of the thermal pack storage cord of this invention being worn and used by user 3740 and including a wrap around the ear configuration having a hook 3742 and arm 3744, said hook secured to the ear and said arm being disposed along the side of the head. Sleeve 3746 has been attached to the arm, holding storage cord 3748 with thermal pack 3750 located in apposition to the skin of the back of the head and neck, and preferably positioned in the neck area. It is understood that the storage cord can be permanently affixed to the arm

forming one piece structure. In this embodiment the arm may include an adjusting mechanism for adjusting to different sizes of heads.

It is understood that a ring shape surrounding the head can also be used or a shape that includes other parts of the face/forehead as long as there is conformation and apposition of the thermal pack to the anatomy of the area, and in particular to the neck area. In order to adjust to different head sizes this invention includes an embodiment with a slit, and the edges of said slit having a VELCRO surface for sealing in different positions and thus reducing/increasing the size of the device. This slit configuration can be applied to any of the embodiments including neck thermal pack, head/neck thermal pack, and ring thermal pack.

The thermal pack can be moldable and the container or bag constructed with materials that are deformable and otherwise pliable over the temperature range of use so as to conform to the anatomy of the neck area. A central essentially slightly convex area in the thermal bag allows for intimate interaction and thermal energy transfer at the neck area, but it is to be recognized that the specific shape of the convex area of the thermal cold/heat pack itself can be slightly varied according to anatomic differences between people.

FIG. 152 shows a back view of a thermal pack storage cord working as an integral one piece, and including a storage cord 3754 having an electronic device 3756 and a thermal pack 3752 permanently affixed to said storage cord 3754, said thermal pack storage cord being anchored to a cap 3758 and worn by a user 3760. The storage cord is attached to the cap by attaching snaps to complementary snaps on the cap. The thermal pack has one pouch about to receive a thermal bag 3762 through slot 3764 in the pouch. The thermal pack is connected to storage cord by arms 3766, said arms being preferably adjustably extendable for moving thermal pack up and down, and thus better positioning the thermal pack in the neck area.

FIG. 153 shows a back view of a thermal pack storage cord, comprised of two parts, a storage cord 3768 having an electronic device 3770 and a thermal pack 3772 releasably anchored to said storage cord, said storage cord being anchored to a cap 3774 and worn by a user 3776. The thermal pack includes means to attach to the storage cord, and preferably has two arms 3778. The arms having have on their free ends attaching means for attaching to the storage cord including hook and loop fasteners, snap-on buttons and the like. By being releasably attached, this thermal pack may not include a pouch, and be comprised of a sealed bag containing heat/cooling material. It is also shown that the bag can have extensions 3780 that can encircle a large portion of the neck and part of the shoulder adjacent to the neck. Any thermal pack may have this encircling extension, but it is preferably used as a releasably attached thermal pack.

The storage cord is shown with ear buds 3782 disposed on the user's ears allowing the user to enjoy music while protecting the brain against hypothermia and hyperthermia. The method also includes removing the storage cord from the hat by detaching the storage cord button from the complimentary snap-on buttons, and then using the same snap-on buttons on the cap to attach the complimentary snap-on buttons at the free end of the arms of the thermal pack. This allows the user to use the same wearable article to provide thermal comfort and safety as well as to provide entertainment. The arms are preferably adjustably extend-

able for moving the thermal pack up and down, and thus better positioning the thermal pack in the neck, shoulder, and back of the head area.

FIG. 154 shows a back view of a cap 3784, worn by a user 3786, and a thermal pack cord 3788 comprised of attachment means 3790 for attaching said thermal pack to a wearable article and at least one pouch 3792 for receiving a thermal bag 3794. The embodiment is illustrated herein as two pouches, one in the left side and one in the right side, and the attachment means are illustrated as a hook and loop fastener. The cap has VELCRO portions 3796 adapted for anchoring the thermal pack cord.

The thermal pack cord includes an upper portion 3798 for anchoring to another article and a lower portion 3800 having a thermal pack. Preferably, the thermal pack portion includes a pouch, but alternatively the thermal pack can comprise of an integral bag filled with gel, and no pouches. In this embodiment the thermal pack cord has thermal transferring capabilities and works primarily as a thermal pack. The thermal pouch portion may be connected to the upper cord portion by adjustable means to adjust the position of the thermal pouch. In this embodiment the upper portion includes and functions as an anchoring means to a wearable article, which is attached to complimentary attaching or fastening means in the wearable article.

FIG. 155 shows a side view of a cap 3784 of FIG. 174, worn by a user, and a thermal pack 3802 attached to said cap by a button 3804 and having a lower portion comprised of a thermal pack in apposition to the skin of the neck.

FIG. 156 shows a back view of an eyeglasses storage cord thermal pack 3806, comprised of two parts, a storage cord 3808 having an electronic device 3810 and a thermal pack 3812 anchored to said storage cord, and disposed under the storage cord. The eyeglasses storage cord thermal pack has two sleeves 3814 for anchoring to the temples of eyeglasses and central portion that has means for holding an electronic device. Any means to hold an electronic device in the central portion of the storage cord can be used. The eyeglasses storage cord thermal pack illustratively has one pouch or pocket for receiving a thermal bag, with a mesh like structure forming the pouch.

Considering that the storage cord has means to hold a variety of hardware as per the principles of the invention, and further considering that means to electrically generate thermal energy such as by wires may be compact, this invention further provides a combination of electrical and chemical generation of thermal energy. Chemicals, such as propylene glycol and similar compounds, efficiently retain thermal energy that can be transferred to another body. Electrical means such as heat generating wires, conductive polymers, a gas-based system, and a thermo-voltaic system can be used to increase or reduce temperature, and may be referred to herein as electric thermal energy systems. The larger electrical and/or electronic parts of those electric thermal energy systems can be housed in the storage cord.

Accordingly, FIG. 157 shows a combined electrical and chemical thermal energy generating system 3816. Illustrated herein as a pouch 3818 having wires 3820, said wires connected to a circuit in the storage cord 3822. A temperature sensor 3824 is included in the pouch to measure the temperature of the pouch. A processor 3826 in the storage cord is adapted to increase/reduce temperature of the electrical thermal energy system and to inform, preferably audibly, the user about the temperature level. A wire from the sensor and the electrical system connect to the circuit and

processor in the storage cord through arm 3828. A wire 3830 connects the circuit to ear bud 3832 for reporting the temperature level.

The processor can also automatically control the level of temperature and delivery of thermal energy thus creating a closed-loop system. It is understood that a sensor can be used in any thermal pouch, such as a non-electrical and chemically based only system. In this embodiment the sensor measures the temperature of the thermal bag, and when the temperature of the thermal bag changes, the sensor informs the user that is time to replace the thermal bag with a new one with the desired temperature. A thermal bag 3834 is about to be placed in the pouch, and the storage cord includes an electronic device 3836 (music player).

FIG. 158 is an alternative embodiment of an electronic thermal pack worn by a user 3838, and including an electronic portion and a thermal pack portion, in which the cord is replaced by a rigid arm and a clip system 3842 to secure the thermal pack to a wearable article 3844. The embodiment further includes a central portion 3840 between the two clips, said central portion working as the holder for an electronic package 3846, in accordance with the principles of the invention. In this embodiment the cord is replaced by an essentially rigid arm, which has a central portion housing the electronic device, and has two clip assemblies in its side portion. Wire 3844 reaches the central portion 3840 through arm 3850. The central portion may include retractable cord, ear bud connections, thermal energy generating systems, and other parts as per this invention. Clips or other clamp assemblies can be used to secure the device to the band of the hat or to any wearable article.

FIG. 159 is an alternative embodiment of a thermal pack storage cord worn by a user 3852, and including a storage cord housing 3854 a GPS system 3856 and a thermal pack portion 3858, in which the thermal pack includes an electric system. The thermal pack includes two arms 3860, 3861, which is releasably connected to the storage cord 3854, one arm 3860 being mechanically connected and a second arm 3861 being mechanically and electrically connected. The electric system is releasably electrically connected to storage cord by means of an electrical connector 3862 located at the end of an arm.

The brain cooling or brain heating device in accordance with the principles of the invention includes a thermal pack having hot and cold pad or pack adapted to fit and match the special anatomy of the neck. The thermal pack includes preferably a pouch for holding a thermal bag, which is preferably flexible and sealed as a pad and has a gel within said pad, with the surface touching the skin having a substantially convex shape. The thermal pack can be part of a storage cord or be an extension of a head mounted gear.

Accordingly, FIG. 160 shows a head mounted gear, illustrated as a helmet 3864, being worn by a user in ghost image) 3866, said head mounted gear having an extension 3868 on the back portion, the extension including a pouch for receiving and holding a thermal bag 3870. A special thermal bag for a helmet is contemplated and may include a bag with larger dimension and different geometry to better fit with said helmet. The portion facing the environment and/or the back portion of the pouch, herein called back portion, preferably comprises insulating material, and most preferably armored material. Although the extension with pouch is shown as permanently affixed to the helmet, it is understood that the extension with the pouch can be releasably secured to the helmet, for example using VELCRO strips on the face of the back portion which match complimentary VELCRO strips on the back of the helmet.

91

It is understood that the thermal pack of the invention can include the head in addition to the neck, and will be referred herein as head thermal pack or head thermal cap. Accordingly, FIG. 161 shows a cross sectional view of the head/neck thermal lining or head thermal cap **3872**, positioned on the head and neck of a user (in ghost image) **3874**, containing gel with said cap thermal pad having the shape and dimensions to match the anatomy of the head and neck, as in accordance to this invention. A preferred thickness of the head thermal pack is equal to or more than 2 mm and less than 40 mm, and more preferably equal to or more than 4 mm and less than 20 mm, and most preferably equal to or more than 5 mm and equal to or less than 10 mm.

Construction of the head thermal pack is performed so as to maintain an intimate apposition to the head and neck. Exemplary manufacturing steps includes a thin flexible plastic being molded using a sphere having head dimensions or slightly larger dimensions than a normal head for fitting on top of the head. A second step includes making a second surface using a mold which has smaller diameter than the first mold. Alternatively the two surfaces can have the same diameter but one has a larger dimension than the other for creating a bag configuration. The following step includes connecting the edges of said two surfaces, and preferably leaving an opening for filling with gel. The next step includes sealing the opening. Another step may include checking the bag for assuring complete sealing and no lack of fluid or material inside said bag.

FIG. 162 shows a side perspective view of a head thermal pack **3876** adapted to fit inside a helmet **3878**, and about to be positioned on the inside of a bike helmet. The surface of the head thermal cap may include fastening means, such as hook and loop fastener **3880**, illustrated herein as a top and side hook and loop fastener areas, which match the top and side hook and loop areas (not shown) of the inside of the helmet.

The head thermal cap preferably lines and matches the entire inner surface of the helmet providing thus comfort and cushioning as well as thermal comfort.

FIG. 163 illustrates a helmet **3882**, made with transparent material, which received the head thermal cap **3884** of this invention, with said thermal cap gel being visible. The head thermal cap can be adapted to fit the design of the helmet, and as shown the perforated areas **3886** of the helmet do not contain portions of the head thermal cap.

FIG. 164 shows a side perspective view of another head thermal pack **3888** being worn by a user **3890** and positioned on the head of said user (in ghost image).

FIG. 165 is a diagrammatic rear cross sectional view of the head thermal pack **3892** at the geometric center of the head showing the head thermal pack positioned on the head of a user **3894**. In order to fit with the anatomy, the thermal pack has different dimensions depending on the part of said thermal pack, which can be observed by the high cut of the head thermal pack, a center of the head next to the ear, and the long portion covering the back of the head. Thickness of the head thermal pack has been augmented for illustration purposes.

FIG. 166 is a diagrammatic side cross sectional view of the head thermal pack **3896** at the geometric center of the head showing long portion covering the back of the head and neck.

It is understood that the wearable article thermal pack of the invention can include various configurations. Accordingly, FIGS. 167A, 167B, and 167C show another embodiment of the thermal pack adapted for another wearable article, illustratively represented as the collar **3898** of a shirt.

92

FIG. 167A shows a collar of a shirt with fastening means **3900** comprised of hook and loop fasteners. FIG. 167B shows a thermal pack **3902** placed on the collar and held in place by complimentary hook and loop fasteners (not shown) located on the surface of the thermal pack opposite to the surface facing the skin. FIG. 167C shows a collar of a shirt with fastening means comprised of snap-on buttons. The thermal pack may include adhesive means **3906** on the surface facing the skin, with adhesive means preferably located on the edge of the pack, in order to achieve stability and intimate skin apposition when using this embodiment.

A head thermal pack can be combined with a thermal pack connected to a storage cord, or to a thermal pack collar. It is understood that any combination of the various embodiments disclosed in this invention are within the scope of the invention.

It is understood that DEP can work as a memory device with control buttons, preferably using MP format for compression, and thus storing music, with said files being decompressed and music played when attached to the electronics housed in the storage cord. The memory device with control buttons allows music to be selected and volume to be changed, with the information stored in said memory device. When the memory device is connected to the electronic in the storage cord, a program stored in the memory will execute the function, and change the volume according to what was programmed, and change the music according to what was programmed using the memory device with control buttons. The memory device with control buttons of the invention may include a processor and a power source. Alternatively, the memory device of the invention works from energy drawn from a separate device, such as a host device. The storage cord may include a USB connector and other connectors for storing and/or receiving information from the controlling memory device. Software in the electronic portion of the storage cord may decompress and amplify the sound files for listening. The memory device of the invention could also be adapted to be plugged in conventional computers and/or audio/imaging systems.

The invention can include a variety of kits combining the different parts of the invention. One exemplary kit comprises an insulating container holding at least one thermal pack. Another kit includes a wearable article and a storage cord, housed in a box, which may further include the insulating container housing thermal packs, or any combination of any of the parts of the invention.

Although the ear bud cords may have the same length, preferably the ear bud cords have a dissimilar length from the origin at the spool to the ear bud at the end of the cord, with one cord being smaller than the opposite cord. However, the external parts of the cords preferably have the same length.

An electronic package can be adapted to receive any wireless signal including satellite and wireless internet signal. It is understood that the storage cord may provide several other motions including changing color of the lens of regular eyewear since the larger electrical parts and battery can be stored away while keeping the frames of eyeglasses light and elegant.

A digital binocular with photo capabilities is also contemplated, in which the electronics stored in the storage pocket and the frame only supports the binocular lens. A digital binocular attached to an eyewear storage cord can also be used, in the same manner as the forehead light embodiment.

A tracking device with internet wireless capabilities can also be integrated into any embodiments of this invention. A

camera, or microphone disclosed in some embodiments can be replaced or add a laser or light source for alignment or measuring distance such as in professional activities or sports such as playing golf or pool, allowing the visual axis to be aligned with a line of the laser light. Only a light laser is located next to the eye while other parts are housed in the storage cord.

Any combination of electronic devices can be used, as well as any combination of wearable articles and of support structures. For example, a C-collar may include a GPS in one side and music player on the opposite side of the C-shaped structure.

An electronic device in the storage cord may include a recorder, in which a small and discrete microphone is placed next to the face and other large parts and memory are stored in the storage cord. An ultrasound device can be housed in the storage cord and prevent attack from dogs by emitting a certain sound, allowing a runner not to have to hold the device. The storage cord may further include a motion sensor to detect someone behind as well as an infrared sensor and/or odor detector to analyze odors and the presence of certain chemical elements, such as biochemical weapons.

Due to the apposition to the skin the storage cord can also include a variety of biological monitoring devices that can capture biological data. In addition delivery of drugs through the skin can be accomplished by adapting iontophoretic devices to the storage cord as well as by placing patches delivering medications on the surface of the cord touching the skin including housing an insulin pump for delivery of insulin and glucose. An improved hearing aid can be achieved by using a microphone to amplify the sound, and then deliver to the ear with the ear bud assembly. Likewise, a camera with zoom and/or magnifying capabilities can be used with the parts divided between the front and back of the head, heavier parts disposed in the storage cord.

Other devices that can be housed and take advantage of the location is a motion device for massaging the neck area. Electronics of an air purifier can be disposed in the C-shape device around the neck and adjacent to the nose. A pedometer can be housed in the storage cord allowing distance to be calculated, as well as a GPS adapted to calculate distance and speed.

A novel retractable cord spool is necessary for this invention. The cord spool includes a wire that has two ends with one end terminating in a connector and the opposite end terminating in speakers or ear buds. Only one end of the wire is exposed outside of a housing. An opening in the housing is formed to expose the opposite end of the wire secured to the spool. The opposite end of the wire is connected to the wire of the ear buds. The opening is located in the center of the spool, and the wire is thereby exposed. In order for the ear buds to remain stationary during pulling of the cord, a fixation point is necessary. Thus, the end of the wire of the spool was anchored (soldered, for example) to the end of the wire extending from the ear bud. This new assembly creates a one way pull, allowing the ear buds to remain stationary while the electronics package connected to the spool is pulled.

FIG. 168 shows the retractable cord spool assembly 3921 including opening 3920 in housing 3921 to expose end 3926 of wire 3924. Anchoring portion 3922 is represented by a soldered connection. The anchoring portion 3922 works as a fixation point. Wire 3924 (shown in broken lines) has two ends 3926, 3928, with end 3926 terminating in anchoring portion 3922 and connected to ear bud 3932. The opposite

end 3928 terminates in connector 3930. Anchoring portion 3922 receives wire 3931 connected to ear bud 3933.

It is understood that two retractable wires and two spools, can be used in series. FIG. 169A shows one wire and spool 3934 connected to the electronics package 3938 and a second wire and spool 3936 connected to the ear buds 3940. The electronics package is located inside a pouch 3942.

FIG. 169B shows the dual spool assembly 3944 having two spools 3946, 3948. Each spool has its own anchoring portion 3950, 3952, respectively, to avoid tension on the wires when the wires extend from spool 3946 or 3948. The end of the wire 3954 of spool 3946 is connected to the end of the wire 3956 of spool 3948.

FIG. 170 shows another embodiment of the storage cord of the present invention. In this embodiment, the right and left wires 3960, 3962 (shown as broken lines) extend from a spool (not shown) disposed within the right and left arms 3964, 3966. The arms 3964, 3966 terminate in an ear anchoring portion represented by right and left hooks 3967, 3969 which wrap around the ear speakers 3968, 3970. In this embodiment the storage cord is secured to the body by an ear supported speaker.

FIGS. 171A-C show another embodiment of the storage cord of the present invention. In this embodiment the storage cord does not have arms. FIG. 171C shows the external face 3972 of a storage cord 3980 with the electronics package 3974 being visible and ear buds 3976, 3978 disposed on each side of the storage cord 3980. In this embodiment the storage cord has an essentially sausage shape (or oblong shape) and does not have arms. The right and left edge of the storage cord in each side has anchoring means (not shown) such as buttons, hook and loop surface fasteners, and the like. FIG. 171B shows the opposite side of the storage cord 3980, having two spaced apart buttons or snaps 3982, 3984. FIG. 171A shows the back of a hat 3986, worn by a user 3988, having two complimentary spaced apart buttons or snaps 3990, 3992. FIG. 171D shows the storage cord 3980 engaged to the back of the hat 3986 using the interengaged buttons on snaps (not shown). Ear bud 3976, 3978 are disposed in the ears of the user.

The present invention further teaches a method and system for making wearable articles such as an electronically enabled hat, and to turn wearable articles into wearable articles adapted for engaging and supporting electronic devices. A two part system is used including a storage cord and a wearable article.

By way of illustration, two preferred embodiments include: (1.) a head mounted gear, such as a hat, having two arms for receiving a storage cord which has complementary shaped sleeves, and (2.) a head mounted gear, such as a hat, having two buttons, two snaps, or a VELCRO hook and loop fastener surface for receiving a storage cord which has complementary shaped buttons or VELCRO surfaces. Any anchoring means can be used including hooks, pins, lapel pins, safety pins, and the like.

Accordingly, FIGS. 172A-C show another embodiment of the storage cord of the invention, but the buttons are replaced by hook and loop portions 4000, 4002, such as VELCRO hook and loop fastener, for anchoring the storage cord 4004 to the wearable article 4006.

The invention teaches a device and method that includes using different amounts of VELCRO hook and loop fastener between the mating parts. The hook and loop portions 4008, 4010 on in the storage cord have a larger area than the hook and loop portions 4000, 4002 on the wearable article,

allowing a snug and comfortable fitting at all times, even when the hat is adjusted to reduce/increase diameter due to different size heads.

FIG. 173A is a side view of a hat 4012 and storage cord 4014, with the storage cord moved in the direction of arrow 4016 to be anchored to the button 4018 on the hat. FIG. 173B shows the storage cord 4014 anchored to the hat 4012 with ear buds 4018 in the ear of a user.

FIG. 174 shows the storage cord 4020 with two sleeves 4022, 4024 about to be engaged on two arms 4026, 4028 of a hat 4030 (shown in phantom).

The invention allows creating a plurality of biologically fit wearable electronics by displacing the weight of the electronics to an anatomic area better fit to support weight without discomfort. As previously disclosed in this application, the electronics of a camera can be subdivided into several portions. Another embodiment includes a camera having a clasp mechanism to preferably secure the camera to the bill of a hat. The camera is connected by a wire to the electronics in the storage cord. The storage cord includes an end portion having a button to be engaged with a mating button on the hat.

Accordingly, FIG. 175A shows a hat 4032 with an anchoring mechanism 4034 including a button 4044 and a storage cord 4038 having a back portion housing electronics 4040, a mid-portion 4042 having a button 4036, and a front portion 4046 having a camera 4048, such as for video or photographs. A wire connects the mid portion 4042 to the camera 4048, said wire being adjustable in length or having a fixed length. The wire can be connected to a retractable spool, and this embodiment may include a second spool preferably located at the mid-portion 4042. It is understood that the embodiment of FIG. 175A does not need ear buds, and the mid-portion of the storage cord may include a button for activating the camera. Anchoring mechanism 4034 can include any of the securing means described for FIGS. 91A to 98.

It is understood that the camera 4048 can be replaced by a light source (including a laser light), a microphone, a screen, and the like. Anchoring means of the hat can be permanently attached and be integral with the hat, or include a clip mechanism for removably mounting the clip on the hat. FIG. 175B shows the storage cord 4038 and camera 4048 anchored to the hat 4032, with clasp mechanism 4050 secured to the bill 4052 of the hat.

Another embodiment includes a visor 4054 having complimentary anchoring means, such as a button, hook and loop surface portions, an arm and a sleeve, and the like. Accordingly, FIG. 176A shows a head mounted gear, illustrated as a visor 4054, having button 4056 for receiving a complimentary button of a storage cord (not shown). FIG. 176B shows a storage cord 4058 anchored to a visor 4054 by a button anchoring mechanism. The storage cord has a screen 4060 with a clasping mechanism 4064 to hold the screen 4060 to the bill 4062 of the visor. The screen 4060 is connected to the storage cord 4058 by a wire that terminates in the button anchoring portion and by a wire 4066 (shown in broken lines) inside the mid-portion of the storage cord 4058.

Similar to FIGS. 175A and 175B, the storage cord has three portions. The front portion however has been replaced by a screen and the mid-portion includes a microphone and ear bud. This embodiment can function with a plurality of different electronic devices including a digital viewing system or a cellular phone with a display. The system may also include a camera. It is also understood that a digital imaging device, such as an iPod® of Apple, Inc. can be housed in the

storage cord, with the visual signal conveyed to the screen secured to the bill of the visor and the audio signal conveyed to the ear bud. Although the system is shown as a removably mounted system, it is also understood that the storage cord viewing system of the invention can be integral with the wearable article, such as head mounted gear, and permanently affixed to the wearable article, with the electronics package being permanently attached or removably attached to the back portion of the storage cord.

FIGS. 177A and 177B show a storage cord similar to that shown in FIG. 176. However, the visor has been replaced by a cap, and the screen has a special hook mechanism for positioning the screen in a geometric center of the bill, and at a furthest distance from the eye, allowing better viewing. The screen may be equipped with an extendable arm for positioning the screen even further away from the eye. A specialized bill comprised of a longer bill or comprised of a portion of the bill that is extendable is also contemplated to allow positioning of the screen at the most comfortable viewing position, and also provides an adjustable mechanism for viewing.

FIG. 177A shows the front portion of the storage cord including a hook assembly 4066 connected to the screen 4068. The mid-portion 4070 of the storage cord anchored to the hat includes a removably mounted flexible microphone 4072 and a surface microphone 4074 in addition to a speaker 4076. The hat may include a second clasp or hook 4079 for supporting the wire to the screen 4068. On the surface of the bill is seen a slidable mechanism, illustrated as a slidable plate 4078, for adjusting viewing distance. Plate 4078 is extended in FIG. 177B. It is understood that screen 4068 can be removably attached to the storage cord. Screen 4068 can have a hinge (not shown) or a folding mechanism to position the screen against the bill when in its folded position. The storage cord of FIG. 177A can include any of the BLUETOOTH devices of this invention, and also may include a permanently affixed BLUETOOTH device in the mid-portion 4070.

FIG. 178 shows a two part storage cord system including a wearable article having a back portion 4080 housing a storage cord. The storage cord has an electronic speaker and screen assembly 4082, which includes a port 4084. The port 4084 is removably connected with a connector 4086 of the wearable article. The storage cord has pegs which are anchored to mating pegs on the hat. It is contemplated that any part or all parts of the embodiments disclosed herein can be permanently affixed to a wearable article.

A variety of anchoring mechanisms are contemplated. FIG. 179A shows an anchoring mechanism of a hat 4088 comprised of a movable arm 4090 terminating in a button 4092 for receiving a mating button 4094 from the storage cord. FIG. 179B shows details of the anchoring mechanism. The movable arm 4090 can be stored in an edge of the hat. FIG. 179C shows the storage cord anchored to the hat. FIG. 179D shows clips 4098 with arms having buttons 4092. The clips are attached to the edge of the hat, and the arms of a storage cord with buttons 4094 anchor to complimentary buttons 4092 of the clip.

The invention teaches a novel hat 4100 with openings for passage of ear buds 4102 and wires 4104 of ear buds. Accordingly, FIG. 180A shows the back portion of a hat with a large brim. The hat has a storage cord 4106 anchored to the back portion of the hat. In this embodiment two openings 4108 in the hat are necessary in order to allow passage of the right and left wire of the ear buds. FIG. 180B is a side view of hat of FIG. 180A.

The storage cord can be secured to a connecting structure to encircle a body portion, for example, encircling the neck and working as a necklace. Accordingly FIG. 181 shows a two part storage cord system 4110, including a storage cord 4112 and a connecting structure 4114. The storage cord has two arms 4116. The arms have a button 4118 in their end portions. The button of each arm of the storage cord is anchored to a mating button 4120 on right and left sides of the connecting structure 4114. The connecting structure has two moveable arms 4122 for adjusting positioning. Arrows 4124 show the movement of the arms of the storage cord toward the mating buttons of the connecting structure to form an essentially circular structure.

FIG. 182A shows a preferred embodiment of the storage cord 4126 of this invention. The storage cord is essentially rectangular in shape and has a plurality of pegs or projections 4128 on its anchoring surface, and an electronics package 4130 and spool 4132 on its rear external surface. The spool is connected to a wire 4134 terminating in ear buds 4136. A wire connects electronics package 4130 to a wire (not shown) in the spool 4132.

FIG. 182B shows an exemplary wearable article, illustrated at the back of a hat, having mating pegs 4138 for anchoring to the storage cord. FIG. 182C is the side view of FIG. 182B.

FIG. 182D shows removable clips 4140 secured to a shirt of a user. The clips have projections for interengaging with the projections of the storage cord. FIG. 182E shows a side view of the removable clip of FIG. 182D.

FIG. 182F shows a storage cord anchored to the removable clip, and worn by a user (in ghost image). Preferably, the number of pegs in the storage cord is larger than the number of pegs in the wearable article for allowing adjustment and snug fit of the storage cord with different size users. FIG. 182G shows two VELCRO patches 4142 spaced apart for receiving complimentary VELCRO surfaces on a storage cord.

FIG. 182H shows a user having adhesive patches 4184 attached to the chest 4186 of the user, in a manner similar to adhesive holding electrodes for an electrocardiogram. The adhesive patches of this invention have a button area 4186 for receiving a matting button of a storage cord. FIG. 182J shows the storage cord 4126 anchored to the adhesive patches on the chest of the user, with ear bud cords located on the top part of the storage cord and ear buds disposed in the ears of the user.

FIGS. 183A to 183E show plan and side views of a variety of anchoring mechanisms for the essentially rectangular or oblong storage cord 4126. FIG. 183A shows a combination of pegs and VELCRO fasteners. FIG. 183B shows a combination of pegs and round buttons. FIG. 183C shows a combination of sliding pin and keyhole recess. FIG. 183D shows a combination sliding plate and round button. FIG. 183E shows a combination of a square button and a round button.

Using sleeves to engage the end of temples of eyeglasses can be limited because the temples invariably have different dimensions ranging from very thin (2 mm) such as in wire frames to very thick (even up to 20 mm) such as in plastic frames of sunglasses. This prevents the use of the storage cord in an universal manner, since the diameter of the sleeve may be too big for some temples and too tight for others. It would be necessary for the user to buy at least two different storage cords with sleeves of different diameters, to fit, for example, a wire frame for prescription lenses and a plastic frame for sunglasses. If the user has a second pair of sunglasses or reading glasses it may be necessary for the

user to have another storage cord for fitting with those other eyeglasses. By requiring several storage cords the invention increases the cost for the user, besides the inconvenience of having to carry different storage cords for the different eyeglasses being worn. In addition, the manufacturer would have to manufacture storage cords with sleeves of different diameters which increases cost for the manufacturer and difficulties with inventory and shelf space.

The present invention teaches a method and device to overcome such a problem, allowing one storage cord to be universal and adapted to receive any dimensions of the temples of eyeglasses. The method and device include the step of using a connecting sleeve and a storage cord that is adapted to be attached to the connecting sleeve. The connecting sleeve has two ends, one end connecting to the storage cord has a fixed dimension sized to receive the arms of the storage cord, and an opposite end having a variable dimension and sized to receive the temple of eyeglasses. Preferably, the storage cord terminates in an essentially rigid portion sized to receive the end of the connecting sleeve.

Accordingly, FIG. 184A shows a storage cord 4188, three connecting sleeves 4190, 4192, 4194, and three temples 4196, 4198, 4200 of eyeglasses having different dimensions. The storage cord includes ear buds and an electronic package permanently attached to the storage cord through a wire terminating in a spool. The storage cord has two portions, a central portion adapted to secure the electronic package and two arms 4202 disposed in each side. The arms illustratively include two different materials such as a soft material in a proximal portion 4204, and a rigid part at the free end 4206, preferably having a round end 4208 for better securing to the connecting sleeve. The three connecting sleeves 4190, 4192, 4194 have the same dimension in one end for receiving the arm 4202 of the storage cord. The three ends of the temples, are illustrated as: a thin wire frame 4196, a mid-size plastic frame 4198, and a bulging end 4200 of plastic frame of sunglasses. The opposite end of the connecting sleeve is sized to match the dimension of the temple: sleeve 4190 has a thin arm, for example 3 mm, for engaging with the temple of the wire frame 4196, the sleeve 4192 has a mid-size dimension, for example 6 mm, and the connecting sleeve 4194 has a large arm, for example 12 mm, for fitting large plastic frames. Arrows 4210 show the movement of the connecting sleeve toward the temple, and arrow 4212 shows the movement of the connecting sleeve toward the arm 4202 of the storage cord.

Thus, by having a connecting sleeve, which is low cost, flexible, and easy to carry, the storage cord can be universally used with any size temple. In this embodiment, since the electronic package is permanently attached to the storage cord, without the connecting sleeve, the user would not have to buy and can three storage cords.

FIG. 184B shows a similar arrangement using buttons 4214, 4216 to interconnect the storage cord and three connecting sleeves. The storage cord includes a right ear bud, a left ear bud with a built-in microphone, and a spool with a wire terminating in a connector. The connector is adapted to connect to a plurality of electronic devices, illustrated as a music player 4222, a cellular phone 4220, and a wireless communication device 4218, such as a Bluetooth device. The music player and the cellular phone have an electrical port 4224 for receiving the connector 4226 of the Storage cord, as shown by arrows. The specialized Bluetooth device of the invention has a power source, a wireless transmitter, a releasably attached microphone rod, and an electrical circuit connected to an electrical connector. The electrical circuit is adapted to connect with the connector

4226 from the storage cord for connecting the Bluetooth device with the ear buds. Bluetooth devices of the prior art do not have an electrical connector (such as a female connector shown in the FIG. **184B**) for releasably connecting with electrical connectors of ear buds and associated microphone in the wire of the ear bud.

FIG. **184C** shows a similar embodiment of FIG. **184B**, but the buttons are replaced by hook and loop fasteners **4230** and a string **4232** connected to the sleeve, and the storage cord has a permanently attached wireless communication device, such as a BLUETOOTH device. FIG. **184D** shows a wearable article, illustrated as a hat, having a permanently or removably secured sleeve **4234**, for receiving the arm **4236** of the storage cord.

FIG. **184E** shows another embodiment for connecting sleeves comprised of a pair of right and left connecting sleeves, each sleeve having an appendage comprised of anchoring means, illustrated as a snap-on button **4238**. FIG. **184F** is similar to FIG. **184E**, but showing an appendage comprised of a plurality of anchoring means, illustrated as buttons **4240**. Any combination of anchoring means such as VELCRO hook and loop fasteners, pegs, and the like can be used as the appendage.

By the electronic package being preferably removably mounted on the storage cord, the same storage cord can be interchangeably used for different electronic packages, and the electronic packages can be interchangeably used in different types of storage cord. Accordingly, FIG. **185** illustratively shows two electronic packages, a music player **4242** and Bluetooth device **4244**. There are three types of storage cords: a storage cord **4246** being flexible and having arms with buttons and no spool; a storage cord **4248** having a pouch, a pin (shown in broken lines) for securing to a wearable article, a spool, and adjustable arms illustrated as clamps, and a storage cord **4250** having a rigid plate and a clip for securing to a bike helmet. Each of the storage cords have a connector **4252** for connecting with an electronic package. Each of the electronic packages have a jack **4254** for receiving the connector. The two electronic packages, as shown by arrows, can be interchangeably connected to any of the storage cords.

Although the electronic package is shown as having a female connector and the storage cord having a male connector, it is understood that the electronic package can have a male connector and the storage cord can have a female connector, and it is also understood that the connector can include pads, such as electrical pads located in the electronic package and/or in the storage cord.

FIG. **186A** shows a kit **4260** including a box **4262**, connecting sleeves **4264**, a storage cord **4266** and an electronic package **4268** illustrated as a digital music player. FIG. **186B** shows another kit **4270** including a storage cord **4272** having a wireless communication device **4274**, such as a BLUETOOTH device, three connecting sleeves **4276**, and a detachable microphone **4278**. The kit of FIG. **186B** can include only the storage cord and connecting sleeves, and in this embodiment the arm **4202** may have a built-in microphone. Any combination of the various embodiments of this invention can be combined and put together as a kit.

FIG. **187A** shows a storage cord **4282** being worn by a user **4280** and connected to a hook **4284** to wrap around the ear, with a wire **4286** extended from the electronic package **4288** to the storage cord. Hook **4284** can include the assembly of FIGS. **101A** to **101D**.

FIG. **187B** shows a storage cord **4290** including a microphone **4292** and an ear bud **4294**, being worn by a user and connected by sleeves **4296** with the temple of an eyeglasses.

A wire **4298** is extended and connected to an electronic package **4300**, illustrated as a cellular phone, removed from the storage cord **4290**.

FIG. **188** shows another embodiment of the storage cord system **4302** of the invention comprised of two parts: a storage cord **4304** having arms **4306** with buttons **4308** and a strap **4310** wrapping around the temple **4312** of eyeglasses. The ends of the strap connect to each other with a snap-on button **4314**. The external portion of the strap has anchoring means, such as button, for receiving complimentary anchoring means of the storage cord. Arrow **4316** shows the movement of the arm of the storage cord toward the strap structure encircling the temples.

FIG. **188A** shows an alternative embodiment comprised of a clip **4318** having an anchoring means such as a button **4320**, a VELCRO surface, and the like on its external surface and next to the temple. The clip is sized to mount on the temple of eyeglasses and to receive a mating anchoring means, such as button or VELCRO surface of a storage cord. FIG. **188B** is similar to FIG. **188A**, however the anchoring means, illustrated as a snap-on button **4322**, is disposed below the temple.

By using a strap like structure secured to the eyeglasses, any size of temples can be fitted and a variety of anchoring means for the strap can also be used. Accordingly, FIGS. **189A** to **189J** show various strap structures secured to different sizes of temples.

FIG. **189A** shows strap with teeth **4324** facing each other and encircling a small, round temple **4326** of eyeglasses. A snap-on button housing **4328** for receiving a complimentary shaped button of the storage cord is shown on an external surface. FIGS. **189B** and **189C** are similar, but the strap in FIG. **189B** encircles a mid-size temple **4330**, and in FIG. **189C** encircles a large irregular shaped temple **4332**.

FIGS. **189D** to **189F** are similar to FIGS. **189A** to **189C**, but the teeth are replaced by a VELCRO hook and loop fastener **4334**, and in FIGS. **189G**, **189H** and **189I** the teeth were replaced by snap-on buttons **4336**.

FIG. **189K** shows the left snap-on button **4338** of the storage cord in movement toward the mating button **4340** on the external surface of the left strap structure encircling the temple of the eyeglasses, with the temple being shown in a cross-sectional view. The same applies to the right side. It is understood that the button of the storage cord can be sandwiched between the two buttons of the strap, and thus in this embodiment there is no need for a button on the external surface of the strap.

FIG. **190** shows a user **4342** wearing eyeglasses. The eyeglasses have a structure **4344** encircling the temple **4346**. The structure **4344** is anchored by a button to the arms **4346** of a storage cord. The arm of the storage cord includes a microphone **4348** and wire **4350** for ear buds.

FIG. **190A** shows an alternative embodiment, in which the structure secured to the temple of the eyeglasses has a microphone **4352**, ear bud **4354**, and an electrical connector **4356**. The connector connects to an electrical jack **4358** on the storage cord. FIG. **190B** shows in detail the structure secured to the temple.

FIG. **191** shows another embodiment of the storage cord of this invention. The storage cord has an arm **4360** that terminates in an adjustable loop **4362** adapted to be secured to the temple of eyeglasses or any rod like structure. FIG. **191A** shows a top view of the storage cord of FIG. **191**, with the wire **4364** from the storage cord shown in an extended position. FIG. **191B** shows the storage cord anchored to a

101

C-shape structure **4366** having ends **4368** that terminates in a T-shape structure adapted to anchor the loop of the storage cord.

FIG. **192A** is a top view of eyeglasses having a right and left strap **4370**, **4372**, each with a button **4374** on its external face for receiving complimentary buttons of the storage cord, as shows by arrows **4376**. FIG. **192B** is a side view of the storage cord anchored to the button of the strap. In this embodiment the storage cord is a mechanical holder and has a receptacle **4378** for receiving an article or device. The storage cord has no electrical parts.

FIGS. **192C** and **192D** are similar to FIGS. **192A** and **192B**, but the storage cord has a VELCRO hoop and loop fastener surface **4380** for securing an article or electronic device to the storage cord. FIG. **192E** shows the storage cord of FIGS. **192C** and **192D** being anchored to an electronics package **4382**. The electronics package having a microphone and an ear bud, illustrated as a wireless radio device or a BLUETOOTH device having a VELCRO hook and loop fastener surface (not shown). The electronics package **4382** is anchored to a mating VELCRO hook and loop fastener surface (not shown) on the storage cord. FIG. **192F** is a side view of FIG. **192E** with the storage cord anchored to a strap structure secured to the temple of eyeglasses.

FIGS. **192G** and **192H** are similar to FIGS. **192E** and **192F**, but the storage cord is essentially rectangular and with buttons **4384** for anchoring the storage cord to a wearable article such as a hat **4386**. FIG. **192H** is a side view showing the storage cord anchored to the hat **4386**.

FIG. **192J** is similar to FIG. **192E**, but the storage cord has a plate **4388** with pegs **4390** for receiving an electronic package. The electronic package has removably attached ear buds **4392** and microphone **4394**. Arrow **4396** shows the movement of the electronic package toward the storage cord, and arrows **4398** show the movement of the storage cord toward the strap on the eyeglasses. FIG. **192K** is a side view of FIG. **192J**, with the storage cord anchored to the strap.

FIG. **192L** shows an exemplary wireless communication device **4400**, such as a Bluetooth device, having removably connected ear buds **4402** and microphone **4404**. The wireless device includes at least one connector, and preferably two connectors for receiving a microphone and an ear bud (or any speaker), internal electronic parts such as transmitter/receiver and associated transmitting/receiving electronic circuit and radio frequency circuits, a battery, ports (such as a USB port), antenna, control buttons, and power source, such as a battery. Although the Bluetooth device is shown with removably connected ear buds and microphone, it is understood that the ear buds and/or microphone can be permanently connected with the Bluetooth device. The Bluetooth device of the invention, such as is shown in FIG. **192L**, can be removably or permanently secured to the back of a hat or any other wearable article, as shown, worn by a user, in FIGS. **192M** and **192N**. Although a Bluetooth device was shown for illustrative purposes, any electronics package can be secured to the storage cord in a similar manner.

FIG. **193** shows a medallion **4406** with arms **4408** having buttons **4410**. The buttons **4410** are adapted to receive and anchor complimentary buttons of a storage cord and the arms **4410** are adapted to receive complimentary sleeves of a storage cord.

FIGS. **194A** to **194G** show a plurality of strap structures for anchoring a storage cord to the temple of eyeglasses. FIG. **194E** shows the external surface of the strap having one button **4412** while FIG. **194A** shows several buttons, allowing positioning of the storage cord at different heights. FIGS. **194C** and **194D** shows the external surface of the strap

102

having a VELCRO hook and loop fastener surface **4416**. FIG. **194E** shows the external surface of the strap structure having pegs **4418**, and FIG. **194F** having a buckle **4420**, and in FIG. **194G** having a pin **4422**.

The strap structures encircling the temples can house a variety of electronics, including a BLUETOOTH device. Accordingly, FIG. **195** shows a strap housing a BLUETOOTH device **4424**, and receiving a signal **4426** from an external device **4428**. Therefore in addition to slip-on and clips the invention teaches a variety of strap-based assemblies for a wireless communication device, such as a BLUETOOTH device, said slip-on, clips, and straps having a configuration and dimension for fitting with a temple of eyeglasses.

It is understood that the principles of the invention apply to any wearable article, and that the storage cord of the invention can be used with any article. Accordingly, FIG. **196A** shows another storage cord system of the invention including a specialized shoe **4430** and a mating storage cord **4432**. The specialized shoe has two spaced apart anchoring means, illustrated as buttons **4434**, on the surface of the shoe, for receiving mating anchoring means of a storage cord. The storage cord includes preferably a wireless transmitter **4436**, including a BLUETOOTH device, for transmitting a signal to a remotely placed device, such as ear buds or speakers for listening to audio or viewing images on a screen. The electronic package can be permanently affixed to the storage cord, or preferably the electronic package is removably attached to the storage cord, and the electronic package can include any electronic device such as music players, UPS systems, tracking systems coupled to GPS systems, and the like, and can also include wireless internet connectivity. Arrows **4438** show the movement of the storage cord toward the shoes for anchoring to the snap-on buttons **4434** on the shoes. The anchoring means such as VELCRO hook and loop fastener or snap-on buttons on the shoes can be integral with the shoe, or alternatively adhesive snap-on buttons or adhesive VELCRO strips are affixed on the surface of the shoe.

FIG. **196B** shows two exemplary removably mounted electronic devices **4436** having a port connection **4438** and a housing **4440** for receiving said electronic device. The electronic device may include a digital music player, a GPS device, a cellular phone, a wireless communication device (e.g., radio or Bluetooth device), a two-way radio, and the like. The housing for receiving the electronic device is similar to other housings previously described, and may function as a mechanical holder and have a battery or the housing may include, as shown, a power source, a transmitter, a receiver, and a processing and transmitting/receiving circuit. FIG. **196C** shows another exemplary removably mounted electronic device having a plug connection and the electronic housing for mating with the plug.

By the electronic housing being removably mounted on the wearable article, illustrated as a shoe, a plurality of different housings can be mounted on the wearable article. Accordingly, FIG. **196D** shows a shoe **4442** with an opening on the tongue for receiving the electronic housing **4444**. Arrow **4446** shows the movement of the electronic housing toward the shoe. The tongue of the shoe has a cavity or pouch **4448** for storing the electronic housing. The electronic housing is versatile and can be mounted interchangeably on a plurality of articles, exemplified in FIG. **196D** as mounted on a shoe and on FIGS. **192J** and **192K** mounted on a storage cord. FIG. **196E** shows a pouch **4450** in the tongue of the shoe with the electronic device anchored to the housing (not shown) and located inside the pouch. Wave

4452 illustrates a wireless signal being transmitted from the shoe. It is understood that a removably attached pouch can be secured to the shoe to store the electronic housing.

The present invention teaches a method and system for mating an electronic package or electronic device to wearable articles by using anchoring means in the surface of the electronic device or coupled to the electronic device which are complimentary, to anchoring means on the wearable article. The invention further teaches a device and method that allows interaction of the electronic device with senses and voice of the user, such as visual sensing and audio sensing.

The storage cord system of the invention includes a storage cord and a mating wearable article. The storage cord system of the invention is versatile and can be used with any article in an interchangeable manner.

It is understood that other variations of the storage cord are contemplated including a shoulder supported storage unit configured as an inverted U structure. The shoulder supported storage unit can include anchoring means, such as buttons, on its surface to anchor mating buttons sown on a garment. Alternatively mating adhesive buttons can be disposed on the shoulder area of the garment for receiving the shoulder supported storage unit. One anchoring means, such as a button, is disposed on the front portion of the garment and a second anchoring means, is disposed on the back portion of the garment. The inverted U structure can be made of a flexible plastic or rubber material and may include a spring system at the center of the U structure to provide tension in the two arms of the U structure for better securing the structure to the shoulder. The shoulder storage unit can also be made of fabric, and thus would only take the inverted U configuration when secured to the garment. The front face of the inverted U has a housing for removably securing an electronic package.

Accordingly, FIG. 197A shows a side view of a preferred embodiment of the shoulder support inverted U-structure **4454**. In this embodiment each of the ends **4456** of the inverted U terminates in an adjustably positionable arm **4458**, such as a flexible gooseneck structure. The adjustably positionable arm is preferably rubberized for comfort and adapted to encircle the shoulder area.

On the front portion of the inverted U there is seen an area or receptacle **4460** for receiving an electronic package, illustrated by a cellular phone **4462**. Arrow **4464** shows the movement of the electronic package toward the receptacle. The shoulder storage unit may include any of the parts previously described for the storage cord including a connector stabilizer structure, retractable spool connected to an electronic package, removably attached ear buds, retractable spool connected to ear buds, and the like in FIG. 197A there is seen a spool **4466** for a retractable cord and a connecting plug.

FIG. 197B shows the embodiment of FIG. 197A being worn by a user, with the flexible arm from the back crossing the flexible arm from the front forming an X underneath the axillary (arm pit) region of the user. The front portion of the inverted U structure has a storage area, and an electronic device, illustrated as a cellular phone, secured to the storage area. A retractable cord spool **4466** for the electronic device is seen below the storage area for the electronic device. A second smaller retractable spool **4468** is connected to the ear bud **4470**, and further connected to the larger spool for the electronic device, which in turn terminates as a connector plug, which is connected to the electronic device. The ear bud is seen in an extended position and the electronic device is seen in a resting position secured to the storage area.

By having the cellular phone supported on the shoulder, the user can talk without having to hold the phone, since the microphone is anatomically fit and located next to the mouth while the ear buds (also in close proximity to the ear) provide the necessary audio delivery system to the ear. This biologically fit configuration allows interaction with the senses and speech in an optimal manner. FIG. 197C shows the bottom surface of the inverted U structure with the flexible gooseneck arms **4458** anchored to the inverted U structure and the storage area on the opposite side (seen in broken lines).

FIG. 197D shows a specialized shirt **4460** of the invention, worn by a user, and sized to receive a shoulder supported storage cord, including anchoring means, illustrated as a snap-on button **4462**, on the external surface of the shirt. Preferably diametrically opposed to the front button there is another button **4464** on the back portion of the shirt. The button on the back of the shirt is illustrated with broken lines. FIG. 197E shows a shoulder supported storage device **4466** anchored to the buttons of the shirt by complimentary buttons on the shoulder supported storage cord. FIG. 197F shows the bottom surface of the inverted U structure with the two snap-on buttons **4468** and the storage area on the opposite side (shown in broken lines).

The inverted U shoulder storage cord can include an external anchoring means. Accordingly FIG. 197G shows a storage cord **4502** secured by a button **4504** (shown as broken lines) to an inverted U shoulder storage unit **4500**. Ear buds from the storage cord are secured by a flap **4506** on the shoulder supported storage unit **4500**.

FIG. 197H shows a shoulder supported storage cord having a storage area for receiving an electronic device **4512**, a retractable cord **4510** connected to ear buds and an electronic device **4508**, a telescopic arm **4514**, and a plate **4516** connected to the telescopic arm and holding the electronic device. The electronic device is illustrated as a digital viewing device. The electronic device is secured to the plate and is shown moving from its position of rest to its viewing position by movement of the telescopic arm **4514**, allowing the screen of the electronic device to be positioned in the visual axis **4518** of the user. The plate can be rotated and tilted for viewing, as shown by curved arrow **4520**. The shoulder supported storage cord is anchored to the garment by snap-on buttons (not shown).

FIG. 197J shows a cross sectional view of an inverted U shoulder supported storage cord placed on a shoulder, and having a spring loaded mechanism **4522** in its geometric center. The mechanism creates tension and moves a free end of the rear arm **4524** and a free end of the front arm **4526** towards each other. This tension represented by horizontal arrows **4528** allows stable positioning and fitting different sizes of shoulders.

FIG. 197K shows a cross sectional view of an inverted U shoulder supported storage cord comprised of a flexible structure **4530** having an essentially inverted U shape structure connected to two adjustably positionable arms **4532** disposed at the end of the arms of the inverted U figure. The front portion of the inverted U has a storage area **4534** for receiving and mechanically holding a device, such as a cell phone. In this embodiment the inverted U shoulder supported structure does not have electrical connections. By virtue of the proximity to the mouth, voice activated dialing is possible, while a discrete ear bud with a short wire (not shown) delivers audio to the user's ears. The inverted U structure can be made of flexible thin plastic, neoprene, leather, fabric, and the like. Two gooseneck arms are

anchored in each side of the inverted U structure. Arrow **4536** shows movement of the device toward the storage area.

FIG. **197L** shows a top view of an inverted U shoulder supported storage cord **4538** shown in an extended position, and having two portions, a front portion and a back portion. The front portion **4540** has a storage area. The storage area has a cross shaped connector stabilizer **4542** and a connecting plug **4544**. The connecting plug is connected to a retractable spool **4546**, and the retractable spool is connected with an ear bud **4548**.

In this embodiment the inverted U storage cord is preferably made of a flexible material. The shoulder supported storage cord or storage strap has anchoring means in each end. A button (shown in broken lines) is located on the opposite surface of the cord for mating with buttons of a garment or other wearable article. Arrow **4548** shows the movement of the electronic device **4550** towards the storage area.

FIG. **197M-1** shows a perspective side view of another embodiment of the shoulder supported storage unit including two adjustably positionable arms **4552**, illustrated as two gooseneck arms, and a specialized articulated and extendable storage housing **4554** anchored to the ends of the gooseneck arms, and adapted to receive an electronic device, illustrated as a cellular phone **4556**. The gooseneck arms have two portions, the end portions having larger flexibility as compared to the mid-portions adjacent to the storage area. The front arm is preferably shorter than the back arm. FIG. **197M-2** is a side perspective view of the embodiment of FIG. **197-1** when worn by a user, showing the two arms crossing underneath the axilla of the user.

It is understood that housing **4554** can include a non-articulated assembly, and comprise a fixed structure adapted to receive an electronic package.

FIG. **197M-3** shows the articulated and extendable storage housing in its extended and unfolded position for viewing, illustrated as an opened flip cellular phone. FIG. **197M-4** shows the articulated arm placing the storage housing in a second position, more conducive for listening, it is understood that the preferred embodiment comprises gooseneck arms. The gooseneck arms affixed to the inverted U storage cord can be replaced by a strap or elastic band.

FIG. **197N-1** shows a cut away view of the specialized, garment of the invention depicting the shoulder portion of a shirt **4560** having one snap-on button **4562** on the back and a second snap-on button on the front **4564** sized to receive the storage cord unit **4566**. The storage cord unit is illustrated as a strap having two complimentary buttons **4568** in its engaging surface **4570**, and having on the opposite surface **4572** a storage housing **4574** including a connector plug **4576** and a retractable cord spool **4578**. Arrows **4580** show the movement of the storage cord towards the complimentary buttons on the garment. FIG. **197N-2** shows a perspective view of the embodiment of FIG. **197N-1** being worn by a user, with the storage housing securing a cellular phone **4582**, and with an ear bud **4584** placed in the user's ear and a microphone **4586** seen in its extended position.

FIG. **197P** is a similar embodiment to the embodiment of FIG. **197A**, worn by a user, including an inverted U structure **4590** connected to two adjustably positionable arms **4592**, with the storage housing which was fixed in FIG. **197A** replaced by an articulated and extendable storage housing **4594**, which is shown in its extended and unfolded position for viewing.

FIG. **197Q** is a similar embodiment to FIG. **197P**, but with the inverted U structure connected with gooseneck arms replaced by a storage cord **4596** (such as a flexible strap),

seen in a front view. The storage cord has buttons **4598**, **4600** in the front and the back (shown in broken lines), and the storage cord having an extendable and articulated storage unit **4602**, shown in its extended position for viewing.

FIG. **197R** is a plan view of an embodiment showing a U-cut shape strap **4604**, with one button **4606** disposed on the back portion and the second button **4608** disposed on the front portion, adjacent to the articulated and extendable storage housing **4610**. After placement on the shoulder, the U shaped strap has an inverted U shape configuration, creating the preferred embodiment of a U-cut shape and inverted U configuration. The storage housing is seen in its extended position and illustrated as securing a digital viewing device **4612**, which is connected to ear buds **4614**, in accordance with this invention. It is understood that other anchoring means such as VELCRO hook and loop fastener strips can be used to replace the buttons as well as a combination of buttons and straps, or a plurality of buttons.

FIG. **198A** shows a front perspective view of another embodiment of the storage cord system of the invention comprised of two parts, the storage cord **4616**, and a specialized electronic device holder **4618**. The specialized electronic device holder, illustrated as securing a cellular phone **4620**, has two arms **4620** which terminate in a snap-on button **4622** for receiving mating buttons **4624** of the storage cord. The specialized electronic device holder preferably includes other features taught by the present invention such as a connector stabilizer and a retractable cord **4626**, as well as a removably mounted microphone **4628**. Arrows **4630** show the movement of the buttons of the storage cord toward the specialized electronic device holder. FIG. **198B** is a side view of FIG. **198A**, showing the cord connected to the electronic device in its extended position. Arms **4620** can also receive sleeves of a storage cord.

FIG. **199A** shows a memory control device **4650** including control buttons **4652**, a dial **4654**, a display **4656**, internal memory, electronic circuitry, and a connector **4658**. The memory control device **4650** is removably connected to housing **4660**. Housing **4660** includes an electronic circuit, chip to convert digital audio signals to analog audio signals, and a circuit connected to an audio system, illustrated as wires connected to a port or stereo jack of ear buds **4662**. Arrow **4664** shows the memory control device **4650** moving toward the housing **4660** in the storage cord **4666**. FIG. **199B** shows the storage cord with the electronic housing and the memory control device anchored in the storage cord.

In use, the memory control device **4650** is removed from connection with housing **4660**. The device **4650** can then be programmed by the user for a particular variety of music or song order and to change volume. When the device **4650** is connected to the housing **4660** including electronic circuitry, the housing is directed by the controls programmed by the device **4650** to operate in a specific manner, and for example change the volume.

The storage cord of the present invention works, besides as a wired and wireless function, as a processing device and sound delivery system, including a processor, illustrated in FIGS. **199A** and **199B**. The processor executes several programs including executing a function by contact with a removably mounted electronic device, referred to herein as a control memory device. In this embodiment, the control memory device works as a detachable electronic device and includes control buttons and memory, preferably using MP format for compression, for storing music, and with said files being decompressed and music played when the control memory device is attached to the electronics housed in the storage cord.

The control memory device with control buttons allows music to the selected and volume to be changed, with the control information stored in the control memory device. When the control memory device is connected to the electronic circuit in the storage cord, a program will execute the function according to the information from the control memory device, and change the volume according to what was programmed, and change the music according to what was programmed by the control buttons of the memory device.

The control memory device with control buttons of the present invention may include a processor and a power source. Alternatively, the control memory device of the present invention works from energy drawn from a separate device, such as a host device. The storage cord may include a USB connector and other connectors for storing and/or receiving information from the control memory device. Software in the electronic portion of the storage cord may decompress and amplify the sound files for listening. The control memory device of the present invention could also be adapted to be plugged into conventional computers, speaker systems, and/or audio/imaging systems.

The present invention also teaches a new Bluetooth device, in which the Bluetooth device has a jack or female connector for connecting to the male connector of the storage cord of the invention. In addition to this audio port, the Bluetooth device of the present invention has an ear supported part and built-in speakers which allow placement around the ear in a conventional manner. The audio port of the Bluetooth device of this invention is connected with an electronic circuit for receiving and converting an audio signal, so as to be transmitted to the stereo plug (or any electrical plug) and deliver sound to the ear buds. By the audio jack the Bluetooth device can be used interchangeably with a plurality of different storage cords as well as other Bluetooth devices, which have audio plugs for connecting to the jack of the Bluetooth device of this invention. It is understood that the electronic devices may include common parts of an electronic device such analog-digital converters, amplifiers, and the like.

The Bluetooth device of the present invention has ear buds (or speakers) not connected to the receiver electronics, and the audio delivery system of the Bluetooth device is not physically integrated with the Bluetooth electronics, as in the prior art. In one embodiment a simple Bluetooth device is achieved, in which the Bluetooth device has only an electronic circuit for acquiring a wireless signal, a power source, a transmitter/receiver, controls, input/output, and an audio jack, but no built-in speakers or built-in audio delivery system. Another embodiment includes all components in addition to a built-in speaker and a holder for ear support.

FIG. 200A shows a preferred embodiment of the present invention including a support structure for the specialized storage frame of the invention, said support structure being preferably a cord, referred to herein as storage cord 4700. The storage cord 4700 has in its geometric center 4701a specialized storage frame 4702. The storage cord 4700 has an essentially rectangular or oblong shape, and has anchoring means in the right and left areas adjacent to its edges, such as buttons, sleeves, Velcro strips, and the like. In FIG. 200A there is one right button 4704 and one left button 4706.

The specialized storage frame 4702 includes a box like-structure 4708 having a retractable cord spool 4710. The box-like structure 4708 has an inside wall 4711 to support the end 4713 of a stereo plug 4712, and another interior wall 4713 to support the end 4715 of the stereo plug connected to a wire 4717.

Commonly used stereo plugs have two portions, a metal portion (free end) and a non-metal end portion, usually a rubberized portion, which is affixed to a wire from the metallic portion. The wall 4513 inside the box 4508 has an opening 4719, preferably a slit for receiving the wire 4717 of the stereo plug 4712 or the end of the stereo plug. The wall 4711 of the box-like structure 4708 located perpendicular to a longitudinal axis of the stereo plug 4712 has an opening 4721 for firmly holding the stereo plug 4712 in place.

The configuration of the specialized housing allows the stereo plug to remain in a stable and firm position for consistently receiving the jack or a female connector of an electronic device. Without the configuration of the invention the stereo plug 4712 would be pulled toward the retractable cord 4710 and the free end of the plug 4712 would face in different random directions, thus not allowing consistent alignment for attaching and detaching an electronic device to the stereo plug 4712. It is understood that the retractable cord can be connected to a female connector for receiving a male connector of a removably mounted device. It is further understood that the connecting and alignment assembly of the invention can be used for electrical connection as well as mechanical connection.

Preferably the stereo plug 4712 is held between two spaced arms. The invention teaches connecting a stereo plug to a retractable wire leaving the free end (that includes the metal portion) of the stereo plug exposed and free to consistently receive a stereo jack (or any audio jack) in alignment with an electronic device. The stereo plug can be extended by human pulling force on the stereo plug and then the stereo plug is retracted to its rest position by the tension of the spring in the retractable cord spool 4710.

Thus, the present invention teaches a method and device for connecting a stereo plug to a retractable cord, and for consistently aligning with and receiving and connecting the end of the stereo plug to a female connector. Without the specialized housing supporting opposite ends of the plug 4712, which includes a wall 4713 inside the box 4708 having a limited size opening 4719, the stereo plug 4712 would be pulled into the spool 4710.

It is understood, that although is much more preferable to have the wall 4713 inside the box 4708, the invention can function without the inside wall. However, in this alternative embodiment the end of the stereo plug rests against the spool and the opening 4721 in the wall 4711 of the box 4708 would be positioned at a mid-portion of the non-metallic portion of the stereo plug 4712.

The specialized structure of the storage cord 4700 further includes connecting the end of the wire from the stereo plug 4712 extending to inside the spool 4710 to a wire that is connected to ear buds 4724 or any device delivering sound). The wire of the ear buds exits from the center of the spool 4710. The wire preferably has a fixation point, preferably soldered to a top of the spool. The specialized wires of the invention include the ear bud wire 4726 to one ear bud 4724 having a different length as compared to the ear bud wire 4728 to the opposite ear bud 4724. This length is measured from the exit point 4730 of the spool 4710 or exit point of the box 4708.

As seen in FIG. 200A, the wire 4728 of the right ear bud is longer than the wire 4726 of the left ear bud. The length of the ear bud wires are similar or are equal from the exit points 4732, 4734 of the storage cord 4700. This specialized configuration of dissimilar length wires allow the best anatomic positioning of the spool next to the electronic device along the longitudinal axis of the storage cord while

allowing the visible part of the wires to have the same length. The areas of the wire passing internally along the storage cord are preferably sandwiched between two layers of material, making the dissimilar configuration of the ear bud wires not visible to an external observer.

The longitudinal axis of the stereo plug **4712** is preferably positioned parallel to the longitudinal axis of the storage cord **4700**, and preferably pointing towards at least one anchoring means, illustrated herein as the right button **4704**. The metallic portion of the stereo plug is visible and located in a second area **4736** of the housing **4702**, which is adapted to receive and store an article, preferably an electronics package, as previously described for the present invention. Preferably the empty area **4736** of the housing **4702** includes a slide ramp structure, as shown, for example, in FIGS. **72**, **73A** and **73B**. Although the electronic device can be removed by using a vertical pulling, the preferred method includes a horizontal pulling. Many variations will be apparent to one of ordinary skill in the art. Exemplarily, the storage frame can include an inverted V with a large angle configuration, in which one win of the V has the spool and the other arm of the V has a housing for receiving an electronic device. In this embodiment, the electronic device is pointing diagonally at about a **45** degree angle in relation to the ground.

When pulled the electronic device moves in a diagonal fashion which is a more biologically fit movement of the arm when grabbing a device in the back of the head. In this embodiment the wire of the stereo plug may be partially folded at a **45** degree angle, and the two wall structures securing the stereo plug may be part of the housing in the arm of the V receiving the electronic device. The opposite arm has the housing for the spool. A wheel (such as a pulley mechanism) between the two arms of the V may be used to facilitate a motion at an angled position.

For a device having a jack of an electronics device located perpendicular to the stereo plug **4712**, an alternative embodiment would include an L-shape stereo plug. In this embodiment the housing receiving the electronic device may include a structure connecting the upper edge of the ramp with a lower edge of the ramp, thus creating a slit in which a wire can pass during removal of the device from the slide ramp structure.

The preferred diameter for the spool is equal to or less than 12 cm, and preferably equal to or less than 7 cm, and most preferably equal to or less than 4 cm, and even most preferably equal to or less than 2 cm. The preferred length of the structure housing the spool and the non-metallic portion of the stereo plug is equal to or less than 90 mm, and preferably equal to or less than 70 mm, and most preferably equal to or less than 52 mm, and even most preferably equal to or less than 42 mm.

FIG. **200B** shows a preferred embodiment of a storage cord similar to FIG. **200A**. All elements of the storage cord **4800** in FIG. **200B** are of a soft material, such as neoprene or cloth, with the exception of the spool **4802** and the connector stabilizer **4804**. The connector stabilizer has two functions, to prevent the stereo plug from being pulled towards the spool and to prevent the electronic device from detaching from the stereo plug.

The spool **4802** is held in place by gluing to the surface of the cord **4800** and/or by securing to the walls of the soft material surrounding the spool **4802**. The connector stabilizer is also covered on both sides by a soft material forming a cavity with an opening **4806** on the opposite side of the spool. The edge **4808** of the opening is seen as a curved dark line, which does not completely cover the connector stabi-

lizer. The end **4810** of the connector stabilizer is left uncovered to allow the user to grab the connector stabilizer, and the electronic device secured by the connector stabilizer. Arrow **4812** shows the movement of the connector stabilizer when removed from the storage cord. Connector stabilizer is any structure that is adapted to receive an electronic device and that is fixed to the stereo plug. The connector stabilizer can have any configuration including a plate, a cross, a hook, and the like, as described previously.

FIG. **200C** shows an alternative embodiment similar to FIG. **200A**. In this embodiment there are sliding guide ramps **4902**. A stereo plug **4904** is fixed between the two spaced apart ramps **4902**. The user can remove an electronics device from the storage cord **4900** in a similar manner as previously described. The device loses its electrical connection when removed from the storage cord **4900**.

It is understood that any of the embodiments of the invention including storage cords of FIGS. **200A** to **200C** can be physically connected as one unit with any article such as wearable articles, forming one single structure.

It is also understood that the thermal pack of the invention can be coupled with any of the wearable articles of this application, and that the thermal pack fitted with a helmet may have a thin egg shell configuration.

The foregoing description should be considered as illustrative only of the principles of the invention. Since numerous modifications and changes will readily occur to those skilled in the art, it is not desired to limit the invention to the exact construction and operation shown and described, and, accordingly, all suitable modifications and equivalents may be resorted to, falling within the scope of the invention.

I claim:

1. Electronic eyeglasses comprising:

a frame including two temples and two lens rim portions interconnecting the two temples, only one of the lens rim portions having a display portion, said display portion being disposed outside a usual visual path of an user and configured to display an image to said user wearing said frame on said display portion,
said frame including multiple components, one of said multiple components being a camera, said camera being configured to transmit an image to said display portion,
a microphone contained in said frame, said microphone being configured to capture sound,
at least one of said two temples housing said multiple components, said at least one of said two temples having at least three temple portions of different dimensions,
said at least three temple portions of different dimensions including a temple terminal end portion at a free end of the at least one of said two temples, a temple front portion connected to said lens rim portion, and a temple mid-portion located between said temple terminal end portion and said temple front portion, said temple mid-portion having a smallest volume of said at least one of said two temples, and
a battery located in said at least one of said two temples, said battery being positioned within any of said at least three temple portions of said at least one of said two temples other than said temple mid-portion having the smallest volume of said at least one of said two temples.

2. The electronic eyeglass of claim 1, wherein said display portion is disposed adjacent to an upper part of the lens rim portion.

111

3. The electronic eyeglass of claim 1, wherein said microphone is a speech command recognizing microphone, said speech command recognizing microphone causing activation of at least one of said multiple components by a speech command.

4. The electronic eyeglasses of claim 1, further comprising a wireless device contained in said frame for communicating with a remote source.

5. The electronic eyeglasses of claim 1, further comprising a transceiver device contained in said frame and a computing device having an electronic connection with said frame.

6. The electronic eyeglasses of a claim 5, wherein said electronic connection includes a wireless connection.

7. The electronic eyeglasses of claim 5, wherein said computing device includes a cellular phone.

8. The electronic eyeglasses of claim 1, further comprising a global positioning system configured to identify the location of the user.

9. The electronic eyeglasses of claim 1, wherein said frame is a pair of goggles.

10. The electronic eyeglasses of claim 1, wherein said frame is an eyeglass frame.

11. The electronic eyeglasses of claim 1, wherein one of said multiple components is a wireless receiver, said wireless receiver is configured to receive at least one message from a remote source.

12. The electronic eyeglasses of claim 11, wherein said display portion receives at least one message from said wireless receiver.

13. The electronic eyeglasses of claim 1, further comprising a remote cellular telephone device having a wireless connection with said frame.

14. The electronic eyeglasses of claim 11, wherein said display portion includes a foldable display for unfolding upon receiving a message from said wireless receiver.

15. The electronic eyeglasses of claim 1, further comprising a memory.

16. The electronic eyeglasses of claim 3, wherein said speech command recognizing microphone is a specific word recognition device, said specific word recognizing device causing activation of at least one of said multiple components by a specific word command of a user.

17. The electronic eyeglasses of claim 1, further comprising a receiver device contained in said frame, said receiver device receives a signal from a remote source, said received signal includes at least one image, and a transmitter device contained in said frame, said transmitter device transmits a signal to a remote device, said transmitted signal including at least one image.

18. The electronic eyeglasses of claim 1, further comprising a sensor contained in said frame for sensing movement.

19. An electronic eyeglasses system comprising:
an eyewear assembly including a frame and a detachable electronics package, said detachable electronics package including multiple components,
said detachable electronics package including a housing, said frame including a lens having a component mounted on the lens, said detachable electronics package being removably connected to the component,
said housing including a wireless transceiver, said wireless transceiver, which is included in said housing, being configured to receive at least one message from a remote source, said at least one message being at least one of an image and sound,
said frame including at least one lens rim portion,

112

said housing including only one display, said only one display, which is included in said housing, being configured to display said at least one message received by said wireless transceiver,

said housing including a global positioning system, said global positioning system, which is included in said housing, being configured to transmit a location to identify the location of the user,

said housing including a camera, said camera, which is included in said housing, capturing at least one of a still image and a video image,

said wireless transceiver, which is included in said housing, being configured to remotely transmit data,

said housing including a processor, said processor, which is included in said housing, controlling at least one of said multiple components in said detachable electronics package,

said housing including a memory, said memory, which is included in said housing, being configured to store data, and

a cellular telephone having a wireless connection with said detachable electronics package.

20. The electronic eyeglasses of claim 19, wherein said frame includes goggles.

21. The electronic eyeglasses of claim 19, wherein said frame is an eyeglass frame.

22. The electronic eyeglasses of claim 19, further comprising a pressure sensor included in said housing.

23. An electronic eyeglasses system comprising:
an eyewear assembly including a frame and a detachable electronics package, said detachable electronics package including multiple components,

said detachable electronics package including a housing, said detachable electronics package being removably connected to said frame,

said housing including a wireless transceiver, said wireless transceiver, which is included in said housing, being configured to receive at least one message from a remote source, said at least one message being at least one of image and sound,

said frame including at least one lens rim portion, said housing including only one display, said only one display, which is included in said housing, being configured to display an image to a user wearing said frame on said only one display, said only one display being configured to display said at least one message received by said wireless transceiver,

said housing including a global positioning system, said global positioning system, which is included in said housing, being configured to identify a location of said user,

said wireless transceiver, which is included in said housing, being configured to transmit data to a remote source, said data being transmitted including said location of said user,

said housing including a processor, said processor, which is included in said housing, controlling at least one of said multiple components in said detachable electronics package,

said housing including a memory, said memory, which is included in said housing, being configured to store data, and

a cellular telephone having a wireless connection with said detachable electronics package.

24. The electronic eyeglasses system of claim 23, further comprising a remote control, said remote control controls at least one of the multiple components included in the detachable electronics package.

25. The electronic eyeglasses system of claim 23, further comprising a camera contained in said frame, said camera capturing at least one image. 5

26. The electronic eyeglasses system of claim 23, wherein at least one of said two temples houses said multiple components, said at least one of said two temples having at least three distinct portions, including a terminal end portion at a free end of the temple, a front portion terminating adjacent to said lens rim portion, and a mid-portion located between said terminal end portion and said front portion, said mid-portion having a smallest volume of said temple portions. 10 15

27. The electronic eyeglasses of claim 23, wherein said frame includes goggles.

28. The electronic eyeglasses of claim , wherein said frame is an eyeglass frame. 20

* * * * *