



US009605224B2

(12) **United States Patent**
Edlund

(10) **Patent No.:** **US 9,605,224 B2**
(45) **Date of Patent:** **Mar. 28, 2017**

(54) **REFINING ASSEMBLIES AND REFINING METHODS FOR RICH NATURAL GAS**

(71) Applicant: **Element 1 Corp.**, Bend, OR (US)
(72) Inventor: **David J Edlund**, Bend, OR (US)
(73) Assignee: **Element 1 Corp.**, Bend, OR (US)
(*) Notice: Subject to any disclaimer, the term of this patent is extended or adjusted under 35 U.S.C. 154(b) by 50 days.

(21) Appl. No.: **14/734,763**
(22) Filed: **Jun. 9, 2015**

(65) **Prior Publication Data**
US 2016/0131424 A1 May 12, 2016

Related U.S. Application Data

(60) Provisional application No. 62/078,505, filed on Nov. 12, 2014, provisional application No. 62/128,682, filed on Mar. 5, 2015.

(51) **Int. Cl.**
C10L 3/08 (2006.01)
C10L 3/10 (2006.01)
B01J 8/02 (2006.01)

(52) **U.S. Cl.**
CPC **C10L 3/08** (2013.01); **B01J 8/0285** (2013.01); **C10L 3/10** (2013.01); **C10L 3/106** (2013.01);

(Continued)

(58) **Field of Classification Search**
CPC B01J 8/067; B01J 8/0285; B01J 8/009; C10L 3/08; C10L 3/104; C10L 3/106; C10L 3/10

See application file for complete search history.

(56) **References Cited**

U.S. PATENT DOCUMENTS

2,151,329 A 3/1939 Page et al.
3,415,634 A 12/1968 Dent et al.
(Continued)

FOREIGN PATENT DOCUMENTS

DE 69120740 11/1996
DE 69219084 7/1997
(Continued)

OTHER PUBLICATIONS

David Edlund, "Methanol Fuel Cell Systems: Advancing Towards Commercialization", 2011, 199 pages, Pan Stanford Publishing Pte. Ltd., Singapore.

(Continued)

Primary Examiner — Lessanework Seifu
(74) *Attorney, Agent, or Firm* — Kolisch Hartwell, P.C.

(57) **ABSTRACT**

Refining assemblies and methods for refining rich natural gas containing a first methane gas and other hydrocarbons that are heavier than methane gas are disclosed. In some embodiments, the assemblies may include a methane-producing assembly configured to receive at least one liquid-containing feed stream that includes water and rich natural gas and to produce an output stream therefrom by (a) converting at least a substantial portion of the other hydrocarbons of the rich natural gas with the water to a second methane gas, a lesser portion of the water, and other gases, and (b) allowing at least a substantial portion of the first methane gas from the rich natural gas to pass through the methane-producing assembly unconverted. The assemblies may additionally include a purification assembly configured to receive the output stream and to produce a methane-rich stream therefrom having a greater methane concentration than the output stream.

27 Claims, 22 Drawing Sheets

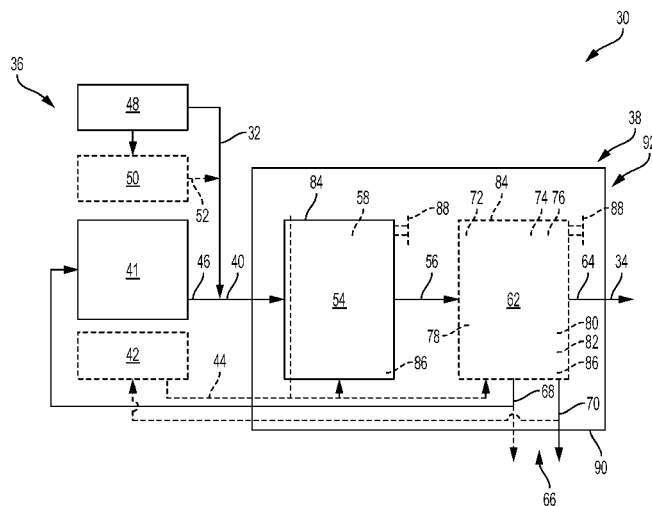

(52) **U.S. Cl.**
 CPC *C10L 2290/06* (2013.01); *C10L 2290/541*
 (2013.01); *C10L 2290/545* (2013.01); *C10L*
2290/548 (2013.01)

(56) **References Cited**

U.S. PATENT DOCUMENTS

3,421,871	A	1/1969	Davies et al.	
3,586,621	A	6/1971	Pitchford et al.	
3,642,460	A	2/1972	Thompson	
3,737,291	A	6/1973	Lhonore et al.	
3,825,490	A *	7/1974	Vachuda	B01D 53/02 208/31 OR
3,838,994	A	10/1974	Aldridge	
3,888,043	A	6/1975	Child et al.	
4,104,201	A	8/1978	Banks et al.	
5,139,541	A	8/1992	Edlund	
5,217,506	A	6/1993	Edlund et al.	
5,259,870	A	11/1993	Edlund	
5,266,283	A	11/1993	Friesen et al.	
5,281,254	A	1/1994	Birbara et al.	
5,393,325	A	2/1995	Edlund	
5,498,278	A	3/1996	Edlund	
5,645,626	A	7/1997	Edlund et al.	
5,861,137	A	1/1999	Edlund	
5,997,594	A	12/1999	Edlund et al.	
6,136,222	A	10/2000	Friesen et al.	
6,152,995	A	11/2000	Edlund	
6,221,117	B1	4/2001	Edlund et al.	
6,319,306	B1	11/2001	Edlund et al.	
6,368,742	B2	4/2002	Fisher et al.	
6,375,906	B1	4/2002	Edlund et al.	
6,376,113	B1	4/2002	Edlund et al.	
6,383,670	B1	5/2002	Edlund et al.	
6,402,818	B1	6/2002	Sengupta	
6,419,728	B1	7/2002	Edlund	
6,451,464	B1	9/2002	Edlund et al.	
6,458,189	B1	10/2002	Edlund et al.	
6,465,118	B1	10/2002	Dickman et al.	
6,494,937	B1	12/2002	Edlund et al.	
6,495,277	B1	12/2002	Edlund et al.	
6,537,352	B2	3/2003	Edlund et al.	
6,547,858	B1	4/2003	Edlund et al.	
6,562,111	B2	5/2003	Edlund et al.	
6,564,579	B1	5/2003	McCartney	
6,569,227	B2	5/2003	Edlund et al.	
6,596,057	B2	7/2003	Edlund et al.	
6,616,841	B2	9/2003	Cho et al.	
6,632,270	B2	10/2003	Edlund et al.	
6,667,128	B2	12/2003	Edlund	
6,719,831	B2	4/2004	Edlund et al.	
6,719,832	B2	4/2004	Edlund et al.	
6,723,156	B2	4/2004	Edlund et al.	
6,767,389	B2	7/2004	Edlund et al.	
6,783,741	B2	8/2004	Edlund et al.	
6,811,908	B2	11/2004	Edlund et al.	
6,818,335	B2	11/2004	Edlund et al.	
6,824,593	B2	11/2004	Edlund et al.	
6,835,481	B2	12/2004	Dickman et al.	
6,858,341	B2	2/2005	Edlund	
6,869,707	B2	3/2005	Edlund et al.	
6,878,474	B2	4/2005	Dickman et al.	
6,890,672	B2	5/2005	Dickman et al.	
6,953,497	B2	10/2005	Edlund et al.	
6,979,507	B2	12/2005	Edlund et al.	
6,994,927	B2	2/2006	Edlund et al.	
7,005,113	B2	2/2006	Edlund et al.	
7,008,708	B2	3/2006	Edlund et al.	
7,052,530	B2	5/2006	Edlund et al.	
7,101,421	B2	9/2006	Edlund et al.	
7,135,048	B1	11/2006	Edlund et al.	
7,147,677	B2	12/2006	Edlund	
7,195,663	B2	3/2007	Edlund et al.	
7,201,783	B2	4/2007	Edlund	
7,208,241	B2	4/2007	Edlund et al.	
7,250,231	B2	7/2007	Edlund	

7,258,946	B2	8/2007	Edlund	
7,297,183	B2	11/2007	Edlund et al.	
7,368,194	B2	5/2008	Dickman et al.	
7,368,195	B2	5/2008	Edlund et al.	
7,390,587	B2	6/2008	Dickman et al.	
7,410,531	B2	8/2008	Edlund et al.	
7,470,293	B2	12/2008	Edlund et al.	
7,476,455	B2	1/2009	Edlund	
7,485,381	B2	2/2009	Dickman et al.	
7,601,302	B2	10/2009	Edlund et al.	
7,632,321	B2	12/2009	Edlund	
7,632,322	B2	12/2009	Edlund	
7,641,795	B2	1/2010	Taylor et al.	
7,659,019	B2	2/2010	Edlund	
7,682,718	B2	3/2010	Dickman et al.	
7,736,596	B2	6/2010	Edlund et al.	
7,771,882	B2	8/2010	Edlund et al.	
7,789,941	B2	9/2010	Edlund et al.	
7,819,955	B2	10/2010	Edlund et al.	
7,828,864	B2	11/2010	Edlund et al.	
7,846,569	B2	12/2010	Edlund et al.	
7,939,211	B2	5/2011	Edlund et al.	
7,977,000	B2	7/2011	Edlund	
7,981,172	B2	7/2011	Edlund et al.	
7,985,510	B2	7/2011	Edlund et al.	
8,021,446	B2	9/2011	Adams et al.	
8,038,748	B2	10/2011	Edlund	
8,057,575	B2	11/2011	Edlund et al.	
8,133,626	B2	3/2012	Edlund et al.	
8,956,428	B2	2/2015	Carnell et al.	
8,961,627	B2	2/2015	Edlund	
2001/0045061	A1	11/2001	Edlund et al.	
2002/0041837	A1	4/2002	Edlund et al.	
2002/0071976	A1	6/2002	Edlund	
2002/0114984	A1	8/2002	Edlund et al.	
2003/0167690	A1	9/2003	Edlund et al.	
2003/0192251	A1	10/2003	Edlund et al.	
2003/0223926	A1	12/2003	Edlund et al.	
2003/0223931	A1	12/2003	Narayan	
2004/0081867	A1	4/2004	Edlund	
2004/0081868	A1	4/2004	Edlund	
2004/0099138	A1	5/2004	Karode et al.	
2004/0197616	A1	10/2004	Edlund et al.	
2005/0188616	A1	9/2005	Bizjak et al.	
2006/0037476	A1	2/2006	Edlund et al.	
2006/0081524	A1	4/2006	Sengupta et al.	
2006/0090397	A1	5/2006	Edlund et al.	
2006/0216562	A1	9/2006	Edlund et al.	
2007/0062116	A1	3/2007	Edlund et al.	
2007/0274904	A1	11/2007	Popham et al.	
2008/0115669	A1	5/2008	Edlund et al.	
2008/0138677	A1	6/2008	Edlund	
2008/0176118	A1	7/2008	Edlund et al.	
2008/0187797	A1	8/2008	Edlund	
2008/0222954	A1	9/2008	Adams et al.	
2010/0064887	A1	3/2010	Edlund et al.	
2010/0261074	A1	10/2010	Edlund et al.	
2011/0250518	A1	10/2011	Edlund et al.	
2011/0256459	A1	10/2011	Edlund	
2011/0256491	A1	10/2011	Edlund et al.	
2012/0058403	A1	3/2012	Edlund et al.	
2012/0208903	A1	8/2012	Gafney	
2013/0011301	A1	1/2013	Edlund	
2013/0090505	A1*	4/2013	Catchpole	C10L 3/08 585/310
2014/0065020	A1	3/2014	Edlund et al.	
2014/0065021	A1	3/2014	Edlund	
2015/0122128	A1	5/2015	Edlund	

FOREIGN PATENT DOCUMENTS

DE	69730071	8/2005
DE	60035418	3/2008
EP	0036268	9/1981
EP	0570185	11/1993
EP	0652042	5/1995
EP	0718031	6/1996
EP	0470822	7/1996
EP	0546808	4/1997

(56)

References Cited

FOREIGN PATENT DOCUMENTS

EP	0783919	7/1997
EP	1010942	2/2003
EP	0800852	8/2004
EP	1272259	10/2004
EP	1516663	3/2005
EP	1135822	4/2005
EP	1523054	4/2005
EP	1679111	7/2006
EP	0951529	8/2006
EP	1252678	11/2006
EP	1189678	7/2007
EP	1290747	2/2009
EP	1138096	10/2010
EP	2359928	8/2011
GB	2432369	4/2010
JP	10052621	2/1998
JP	2003277019	10/2003
JP	2003282119	10/2003
JP	2007099528	4/2007
JP	2008171815	7/2008
JP	2008285404	11/2008
TW	200404739	4/2004
TW	200629635	8/2006
TW	200740014	10/2007
WO	8806489	9/1988
WO	9919456	4/1999
WO	0022690	4/2000
WO	0056425	9/2000
WO	0108247	2/2001
WO	0112311	2/2001
WO	0112539	2/2001
WO	0126174	4/2001
WO	0150541	7/2001
WO	0150542	7/2001
WO	0168514	9/2001
WO	0170376	9/2001
WO	0173879	10/2001
WO	0193362	12/2001

WO	0238265	5/2002
WO	0249128	6/2002
WO	02069428	9/2002
WO	03002244	1/2003
WO	03026776	4/2003
WO	03077331	9/2003
WO	03086964	10/2003
WO	03089128	10/2003
WO	03100900	12/2003
WO	2004038845	5/2004
WO	2004091005	10/2004
WO	2005001955	1/2005
WO	2005091785	10/2005
WO	2005119824	12/2005
WO	2006033773	3/2006
WO	2006049918	5/2006
WO	2006050335	5/2006
WO	2006133003	12/2006
WO	2007035467	3/2007
WO	2007037856	4/2007
WO	2008008279	1/2008
WO	2008033301	3/2008
WO	2009008962	7/2009
WO	2010033628	3/2010
WO	2010118221	10/2010
WO	2011059446	5/2011
WO	2012067612	5/2012
WO	2014099606	6/2014

OTHER PUBLICATIONS

International Searching Authority of United States Receiving Office, International Search Report, Jan. 28, 2016, 2 pages.
 International Searching Authority of United States Receiving Office, Written Opinion, Jan. 28, 2016, 20 pages.
 United States Patent and Trademark Office, Office Action for U.S. Appl. No. 14/820,256, Oct. 13, 2016, 35 pages.
 United States Patent and Trademark Office, Office Action for U.S. Appl. No. 14/937,629, Feb. 3, 2017, 40 pages.

* cited by examiner

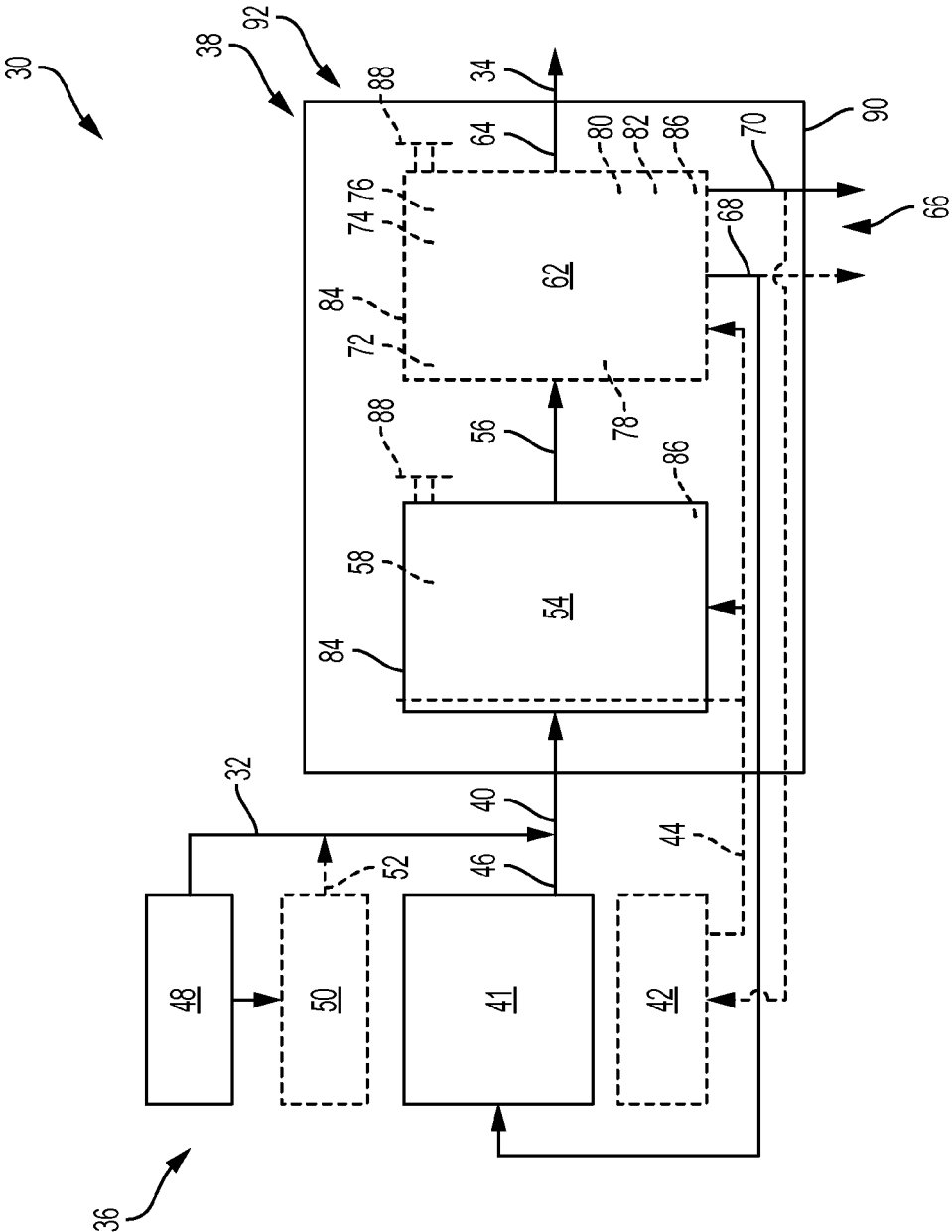

FIG. 1

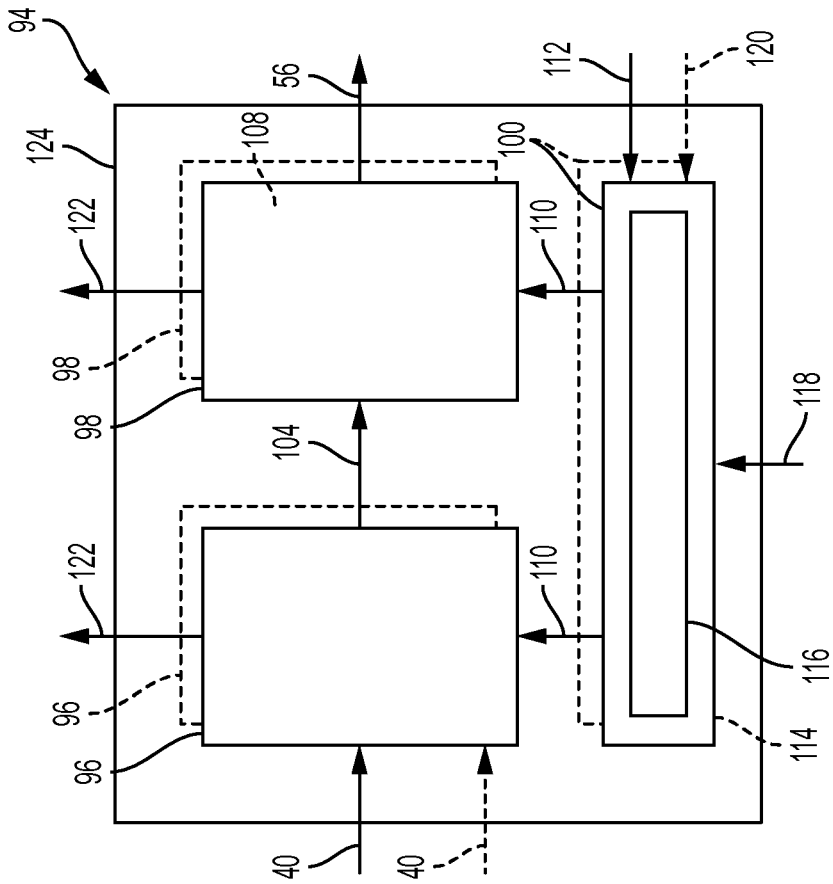

FIG. 2

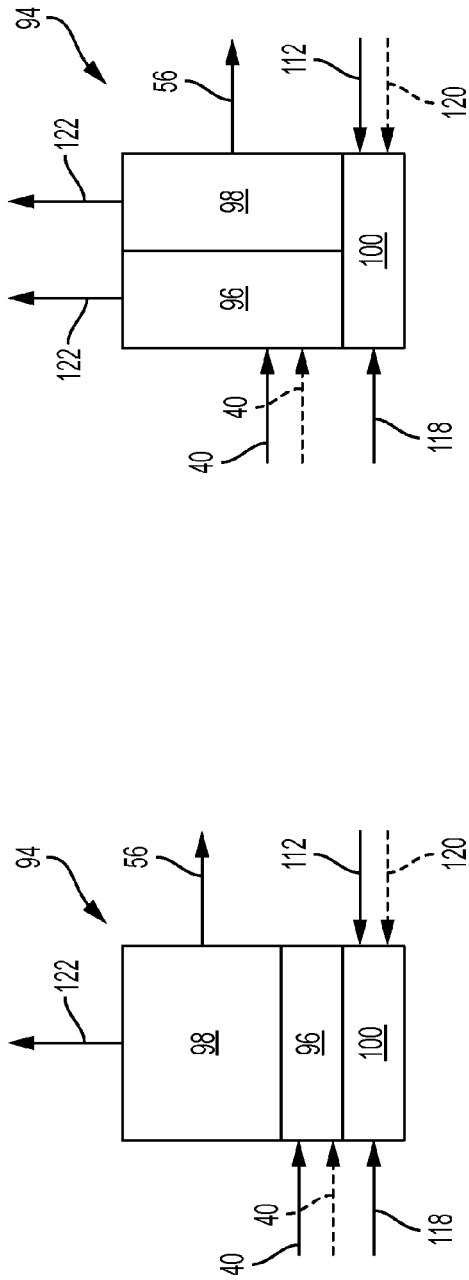

FIG. 4

FIG. 3

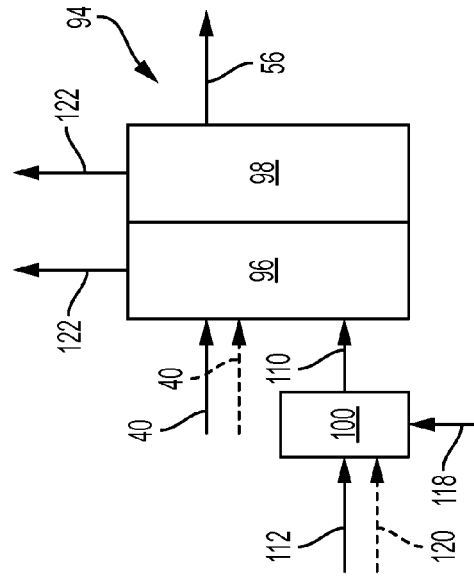

FIG. 5

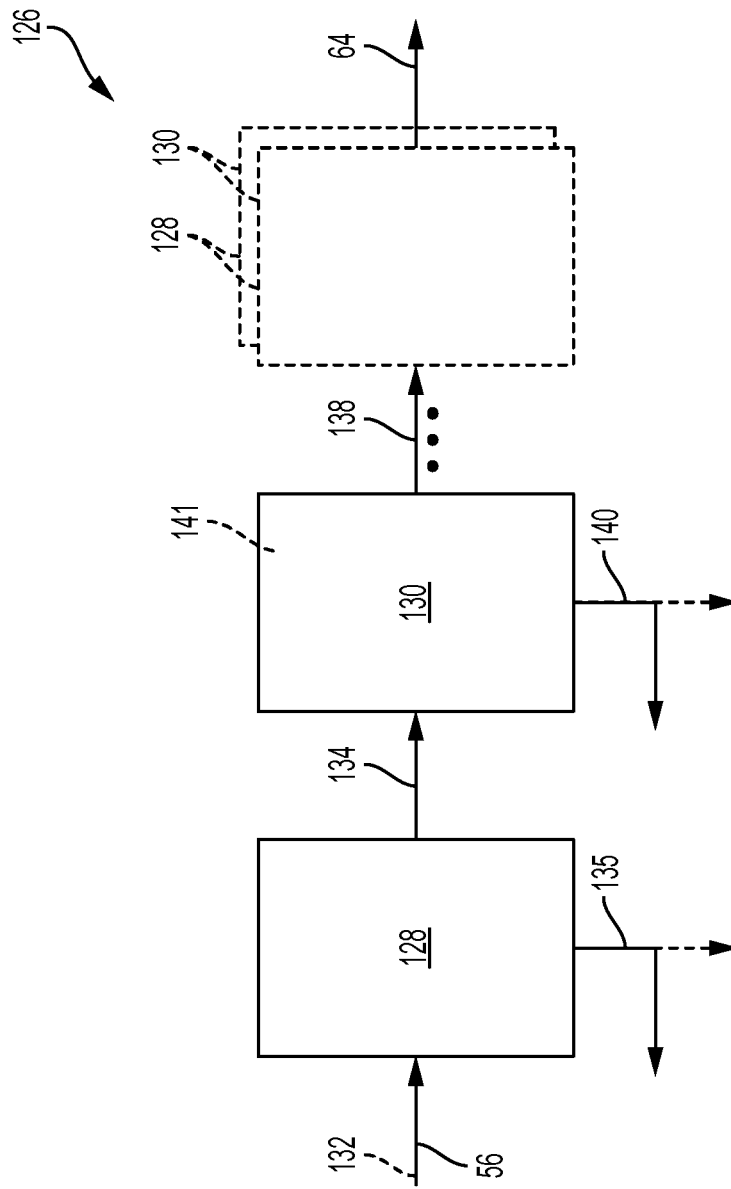

FIG. 6

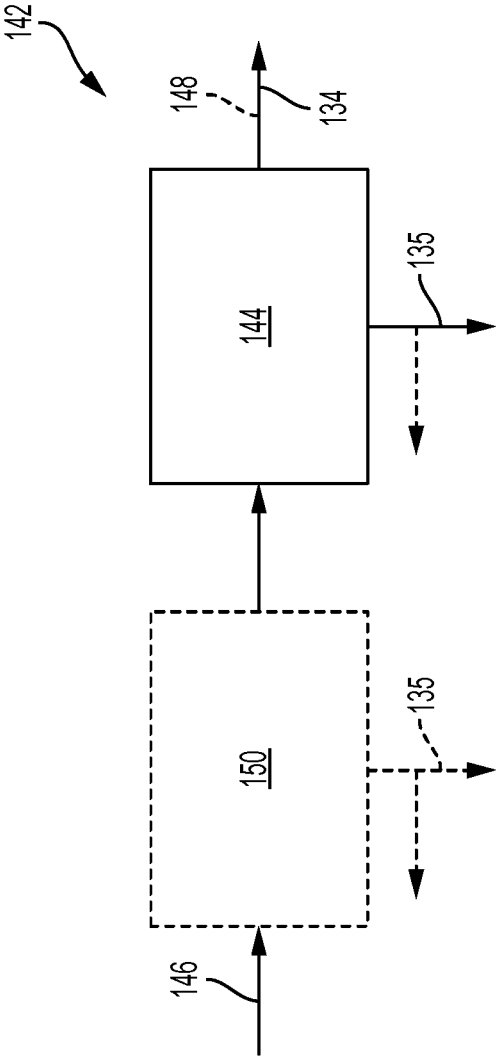

FIG. 7

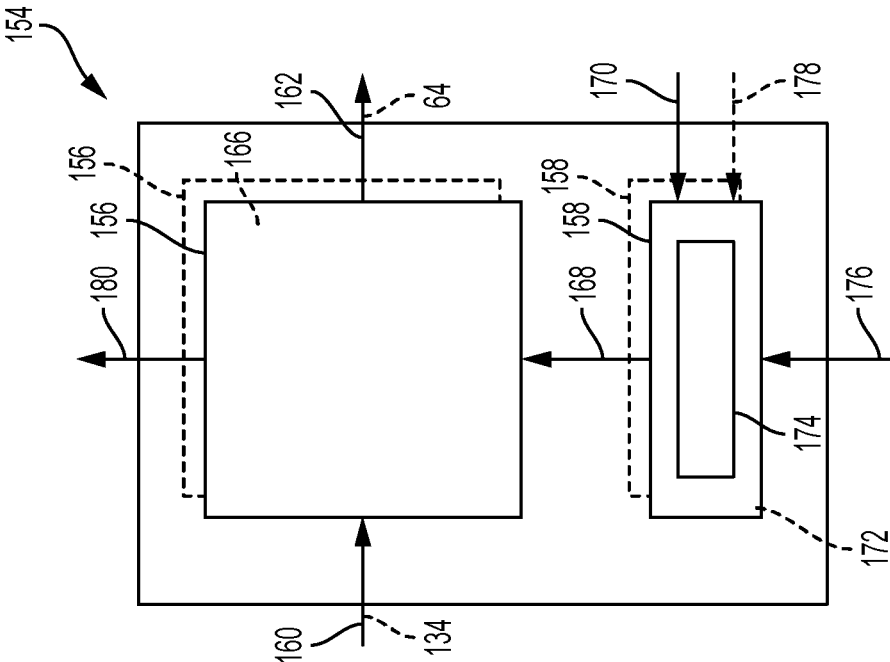

FIG. 8

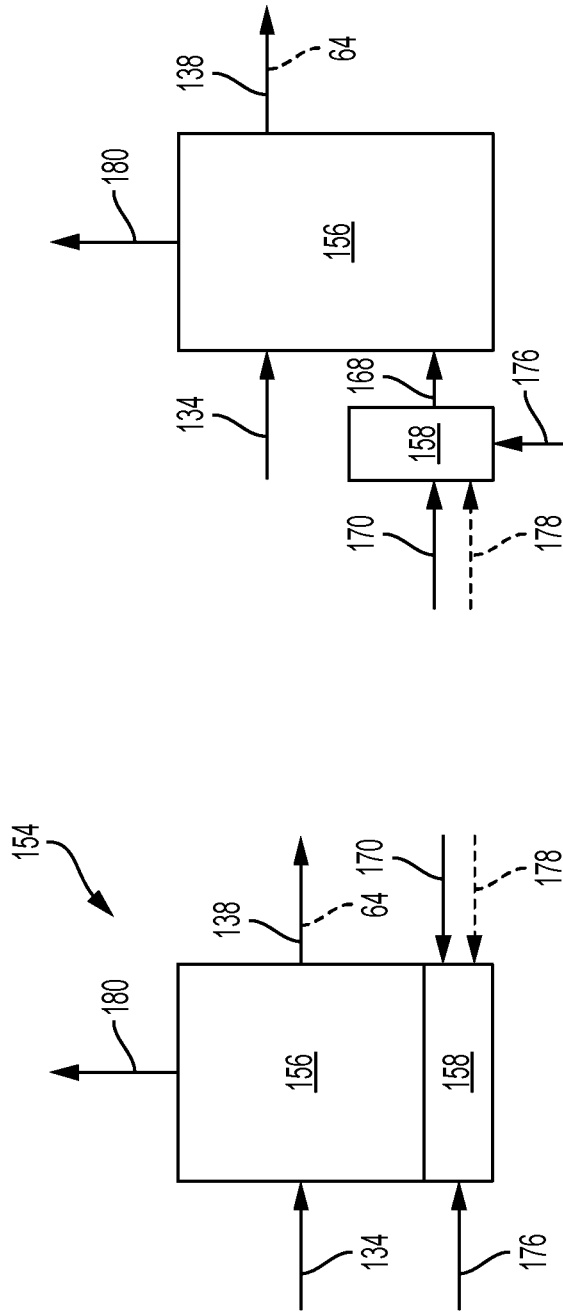

FIG. 9

FIG. 10

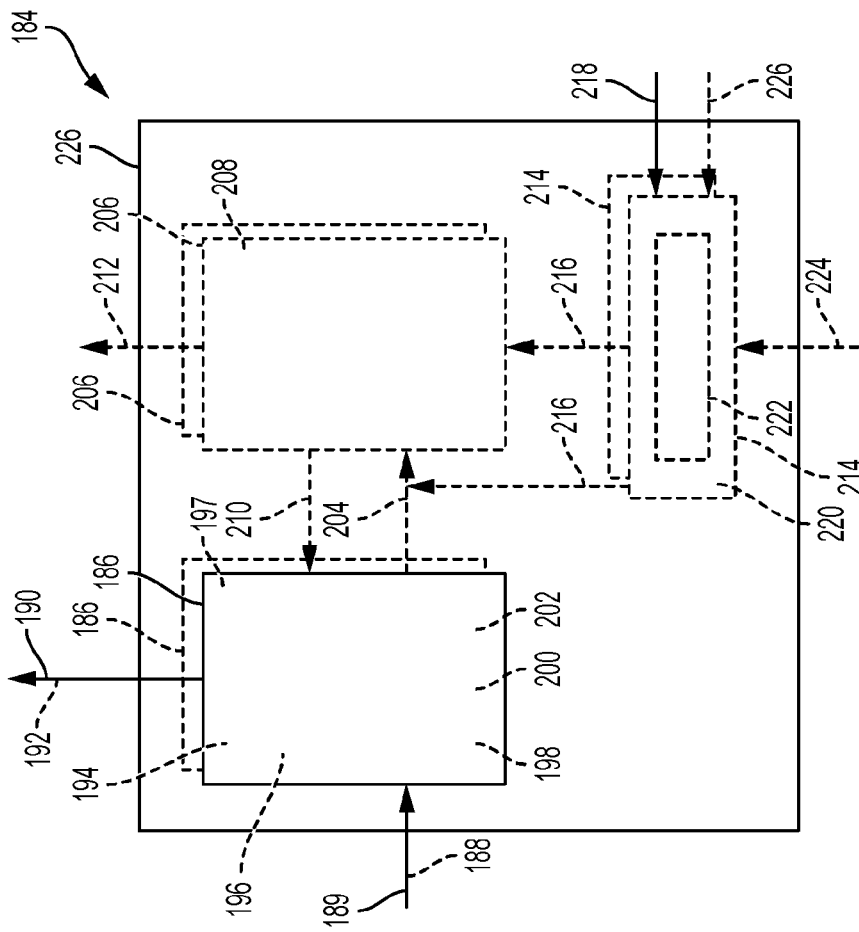

FIG. 11

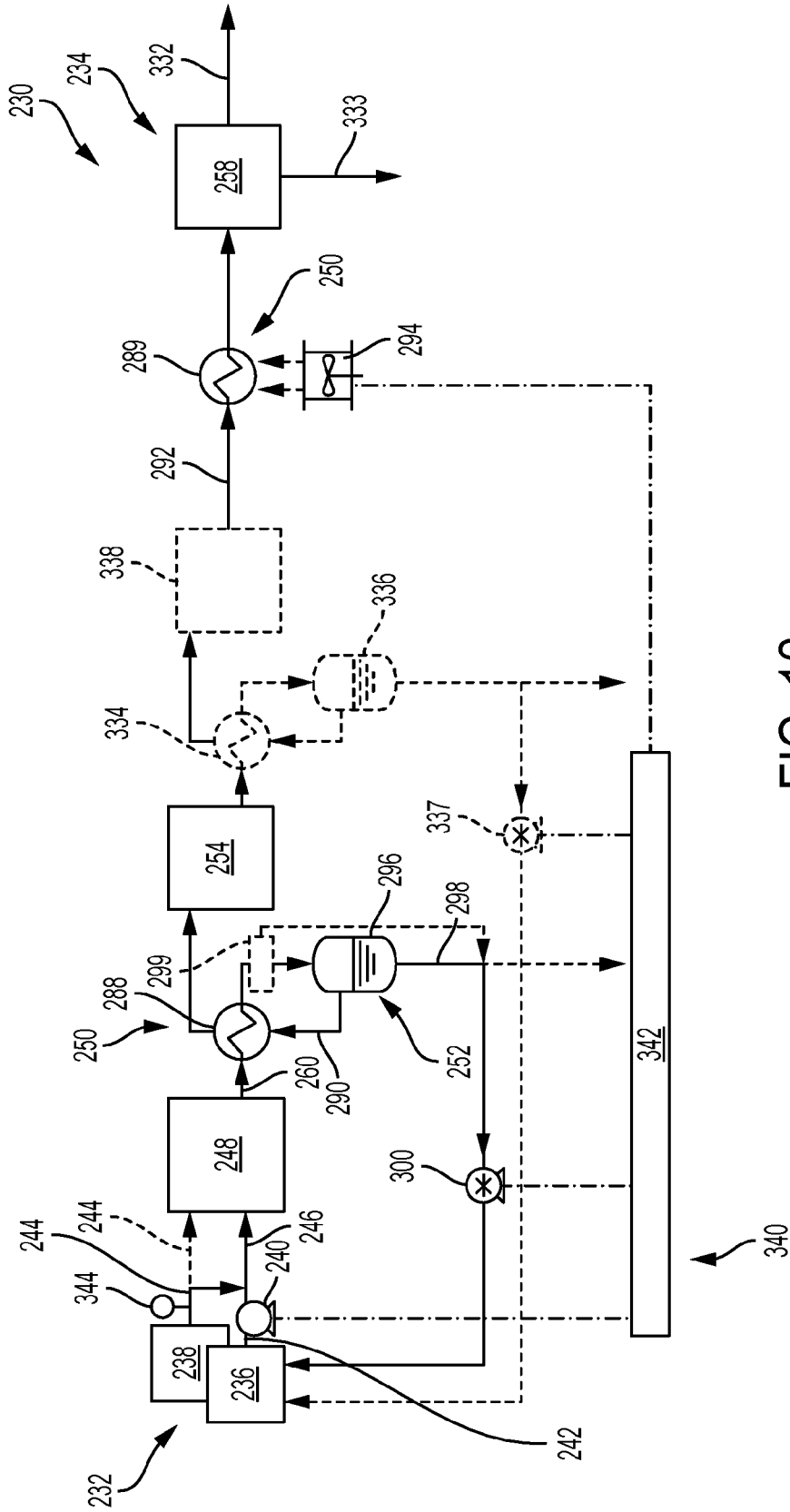

FIG. 12

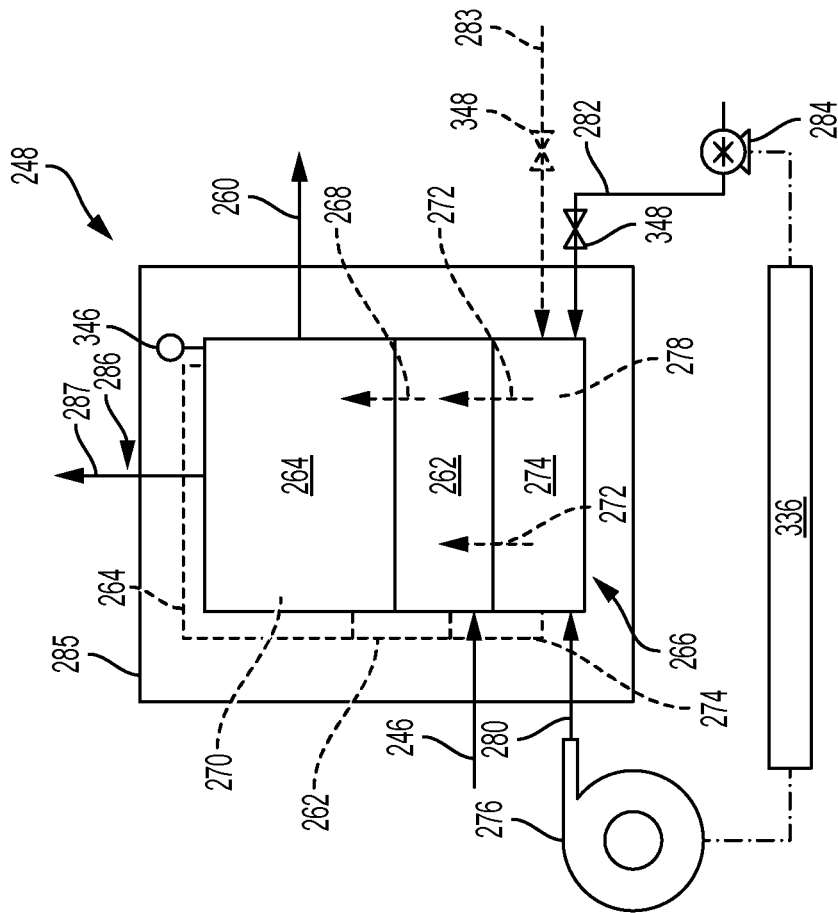

FIG. 13

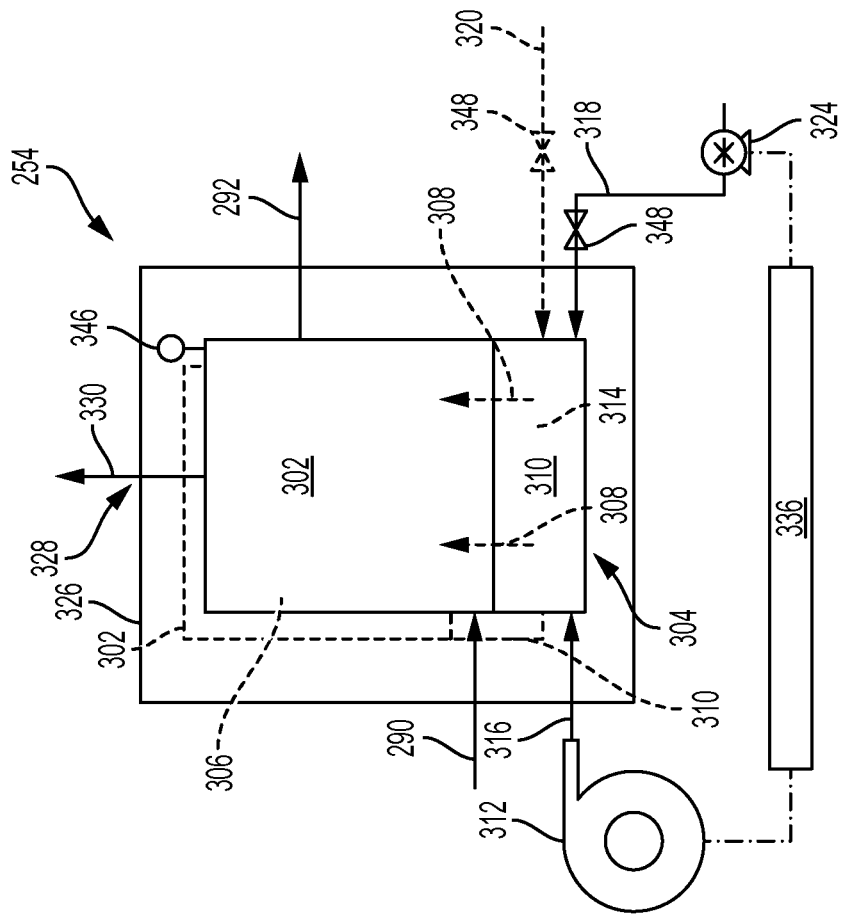

FIG. 14

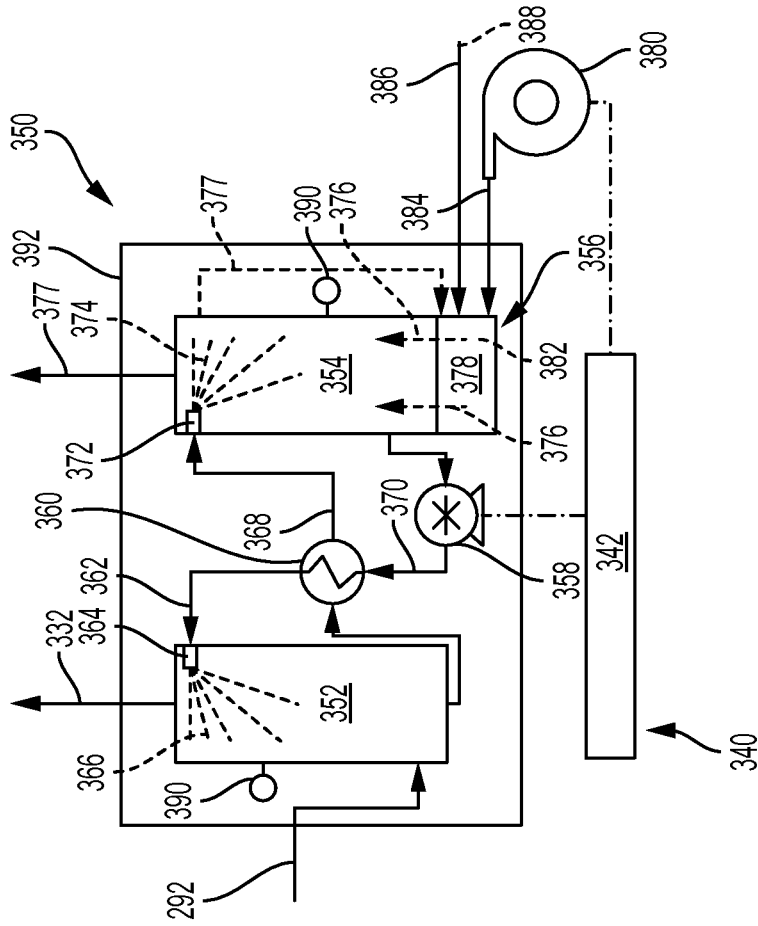

FIG. 15

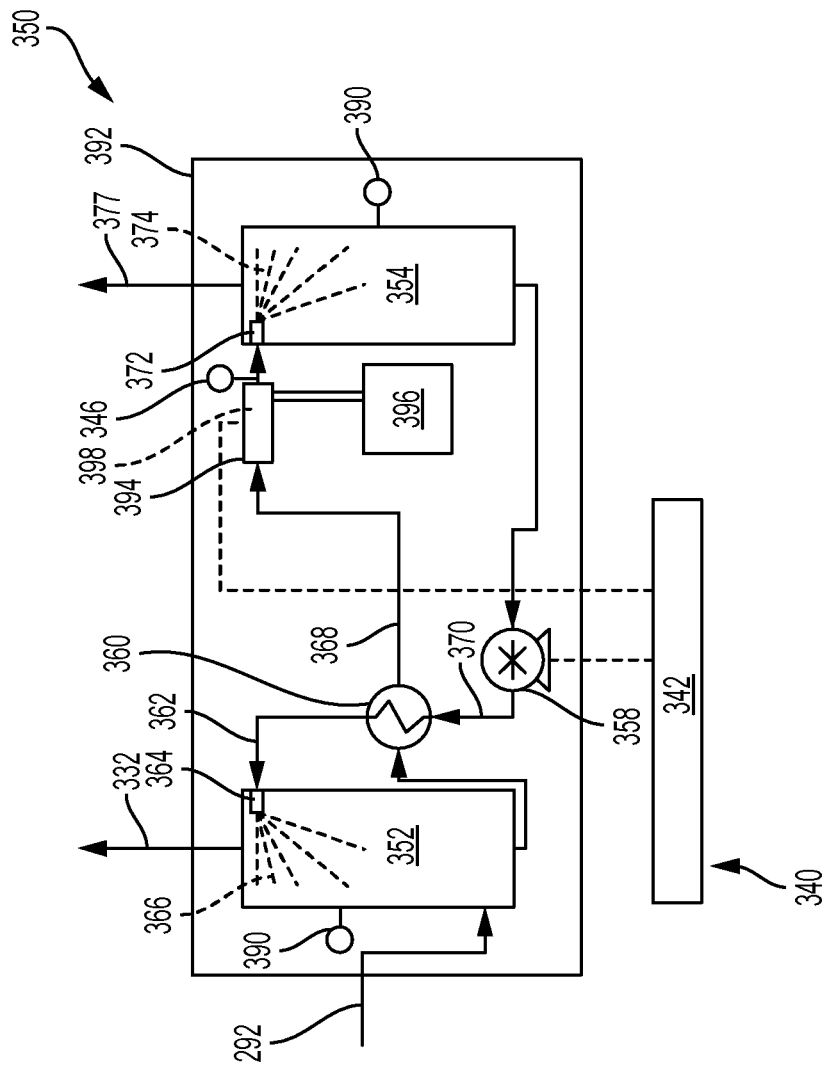

FIG. 16

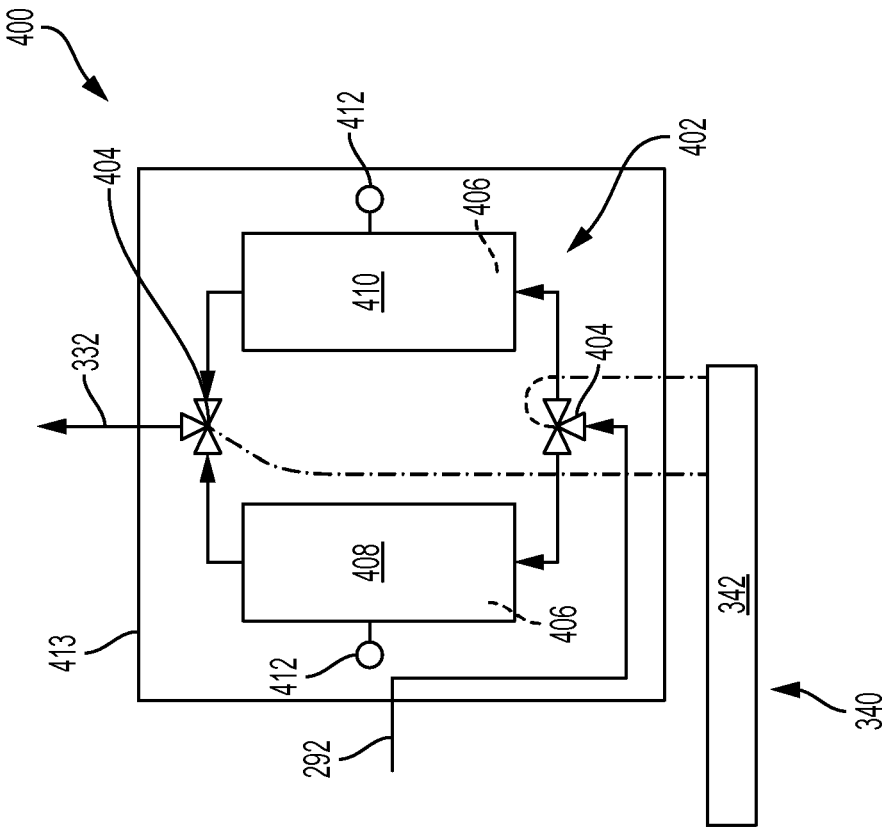

FIG. 17

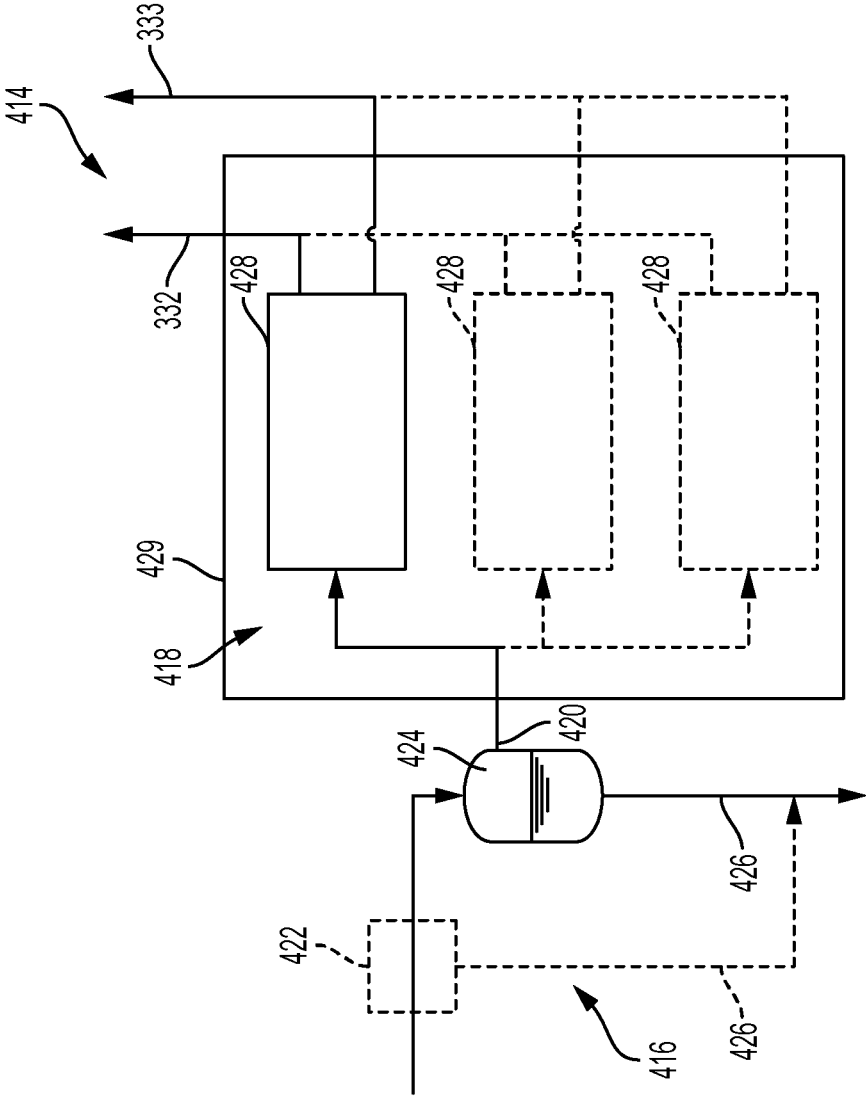

FIG. 18

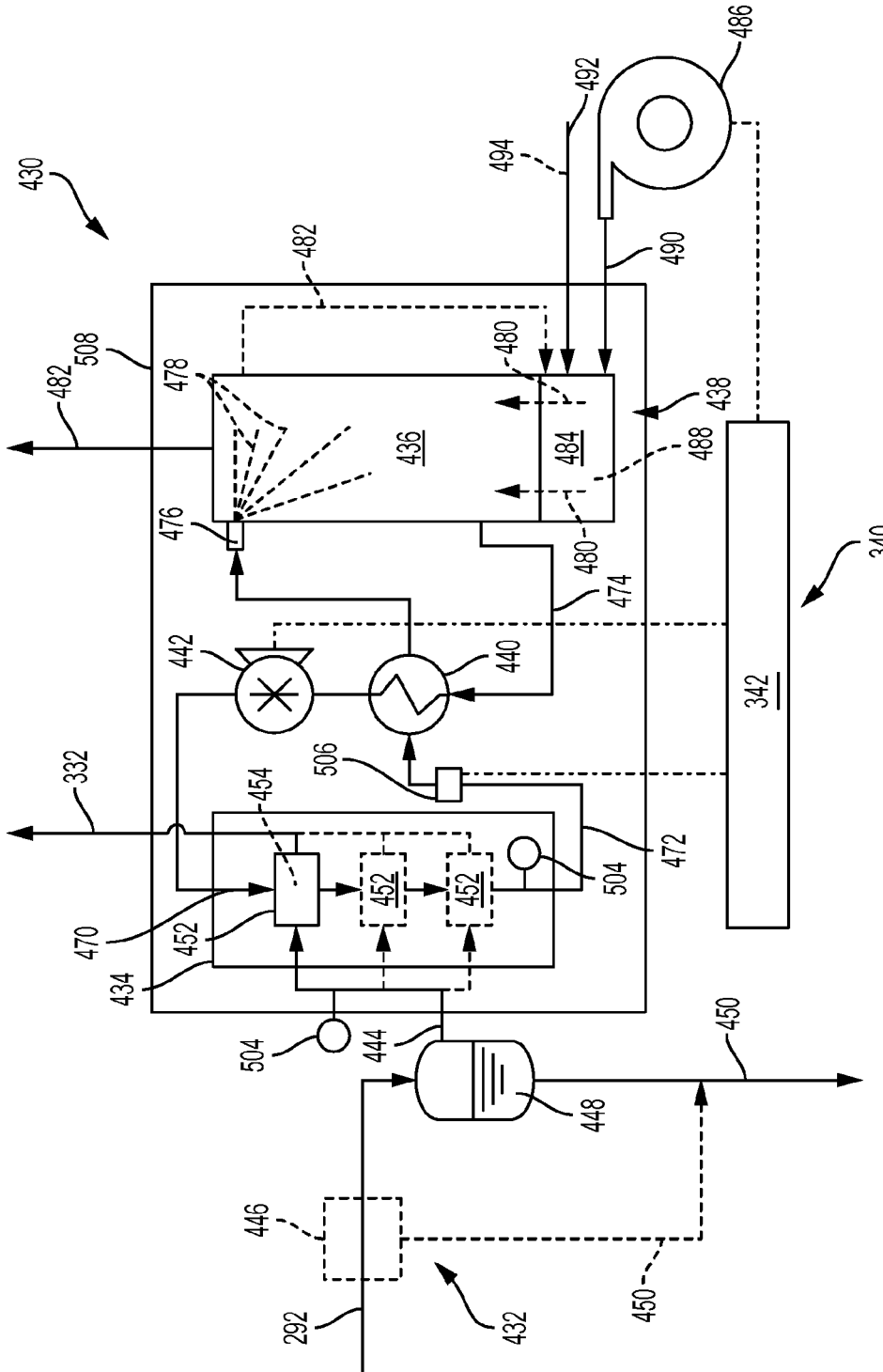

FIG. 19

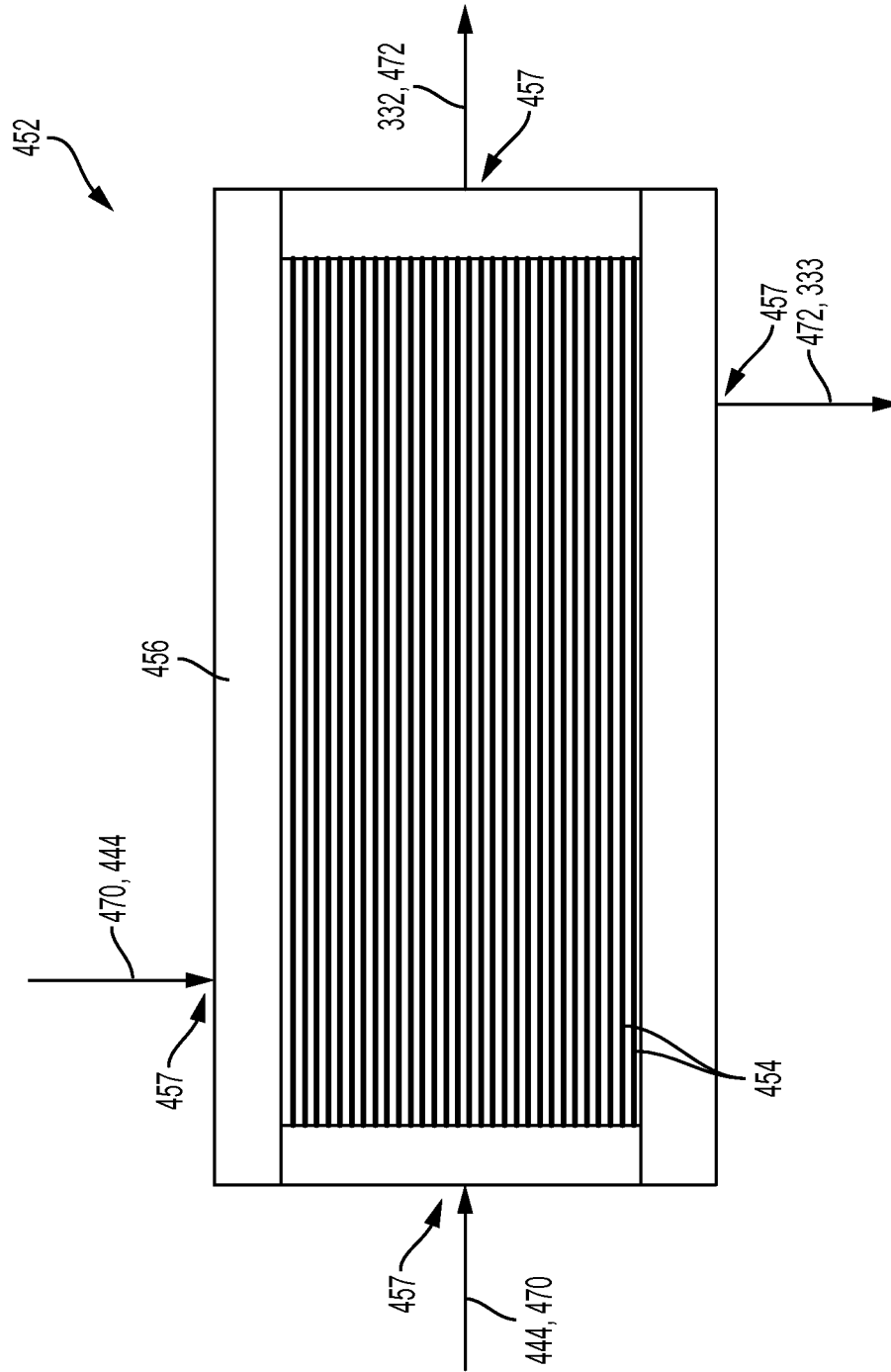

FIG. 20

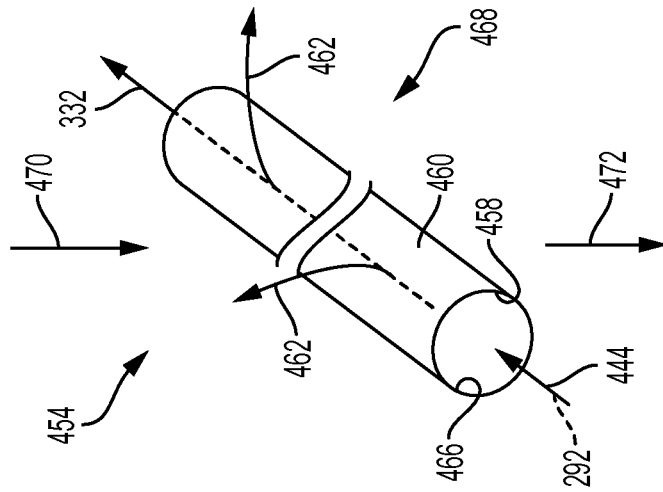

FIG. 21

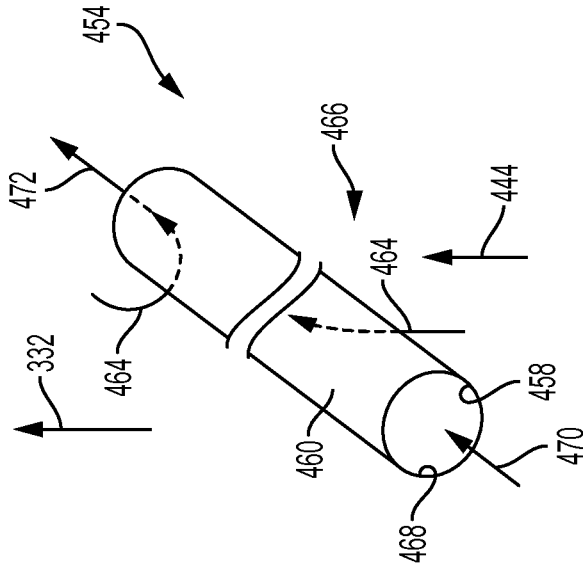

FIG. 22

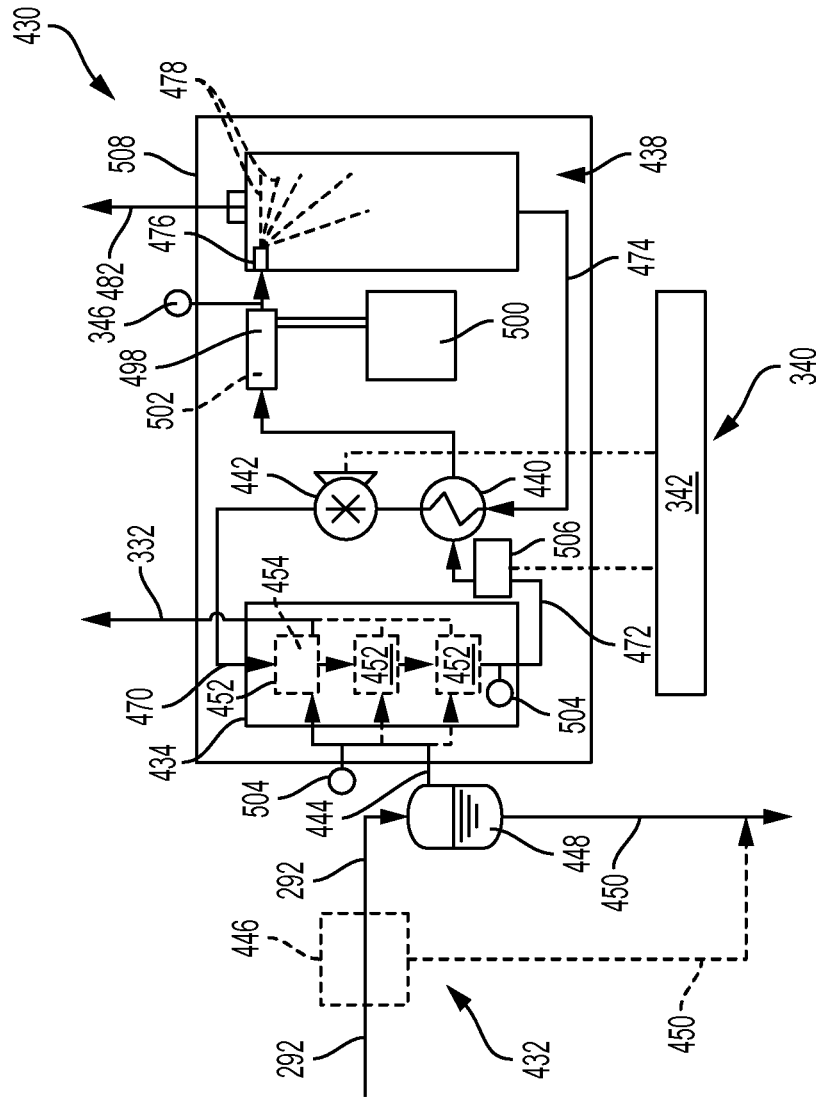

FIG. 23

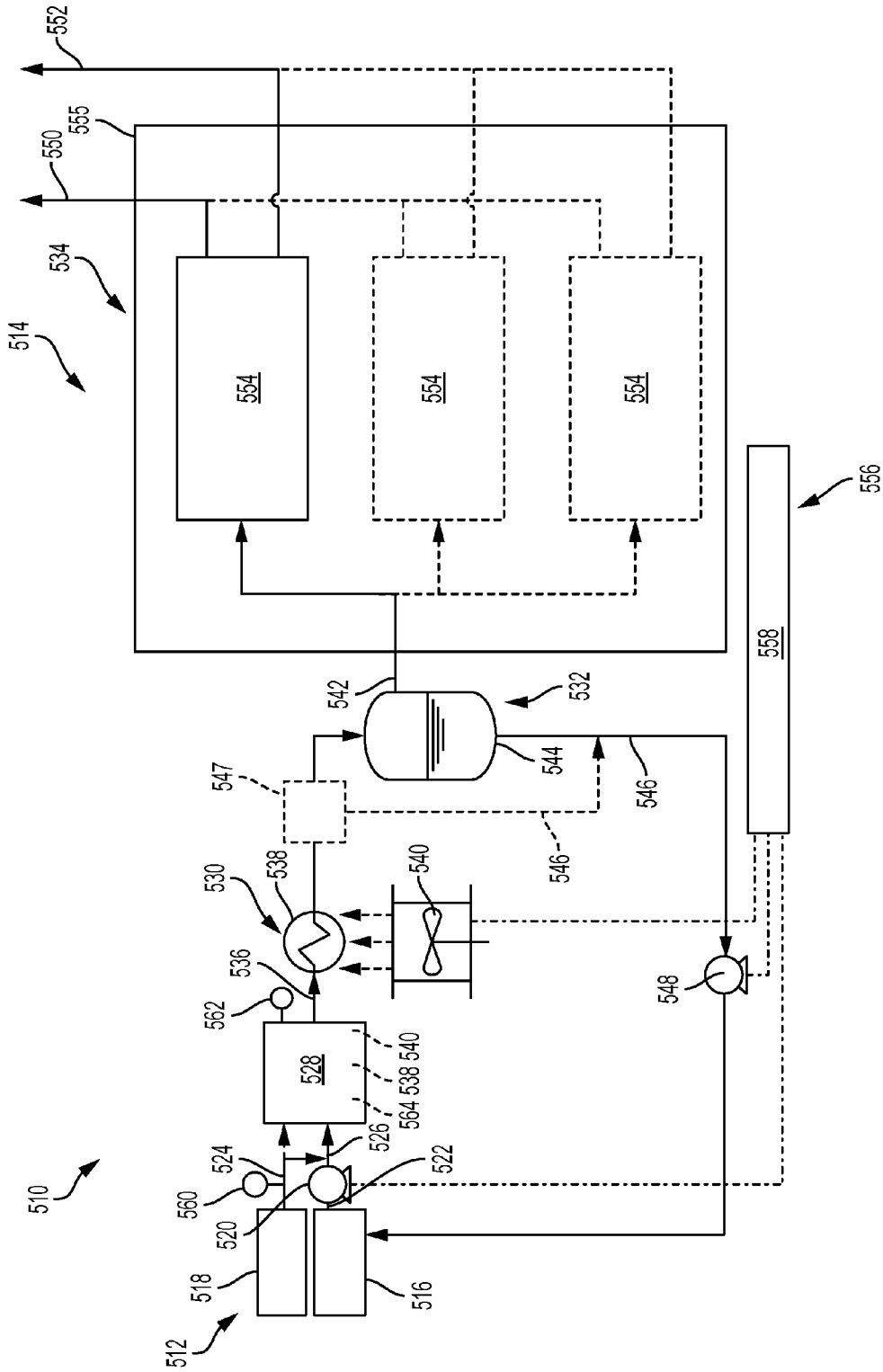

FIG. 24

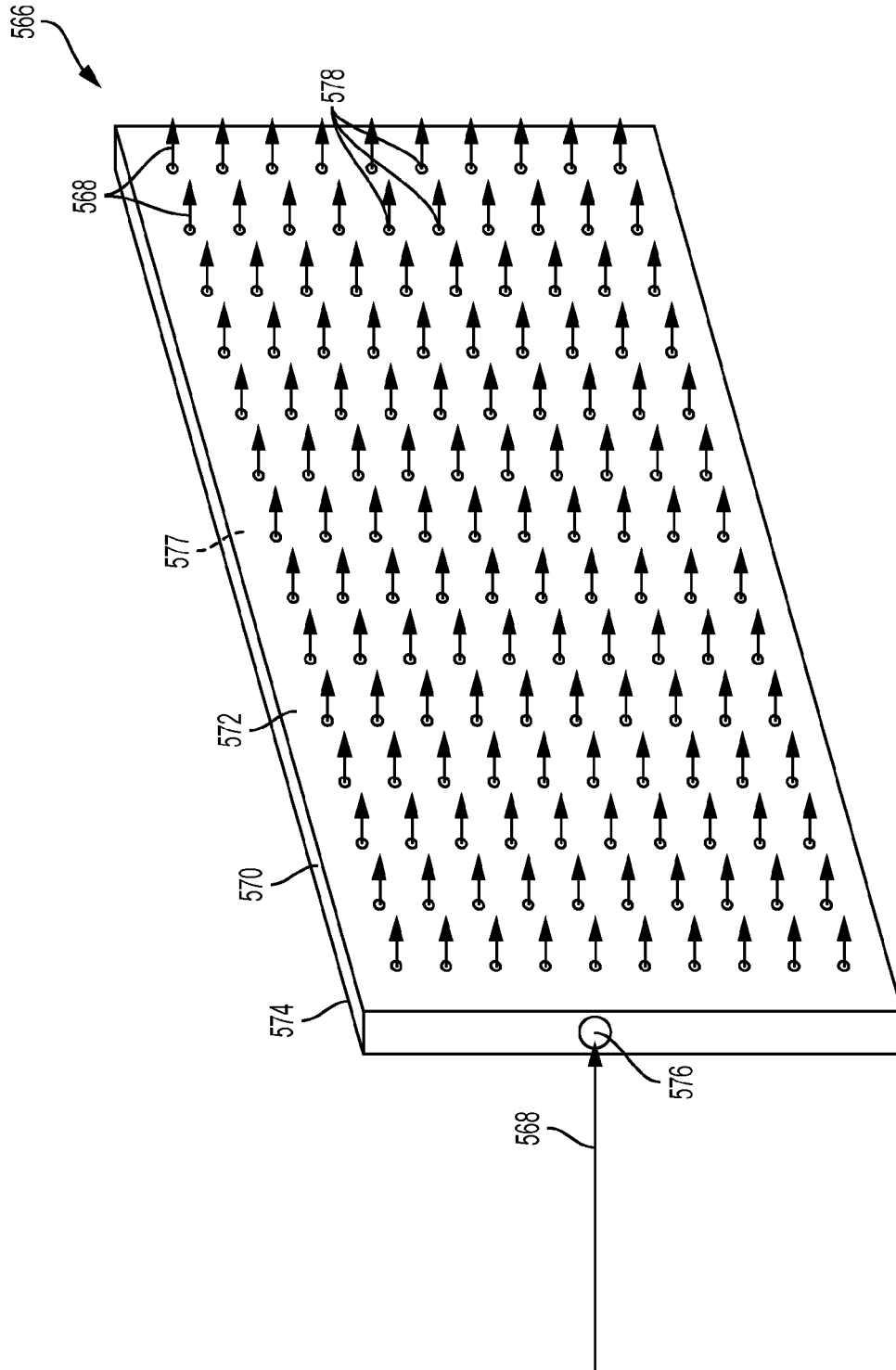

FIG. 25

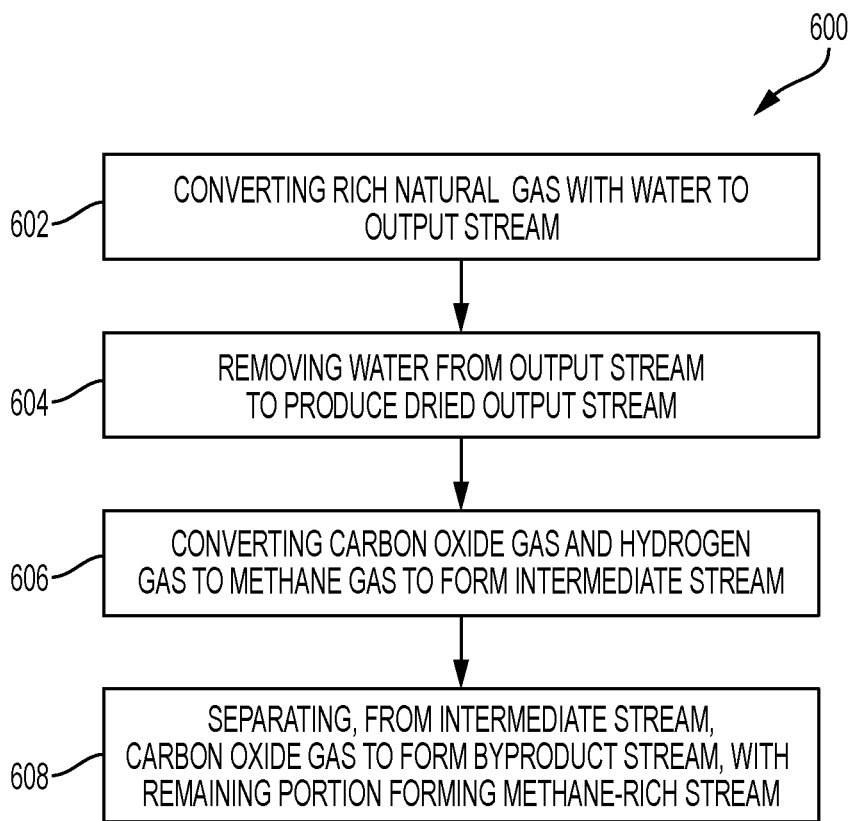

FIG. 26

REFINING ASSEMBLIES AND REFINING METHODS FOR RICH NATURAL GAS

CROSS-REFERENCE TO RELATED APPLICATIONS

This application claims the benefit of U.S. Provisional Patent Application Ser. No. 62/078,505, which was filed on Nov. 12, 2014 and entitled "Process and Method of Refining Wet Natural Gas." Additionally, this application claims the benefit of U.S. Provisional Patent Application Ser. No. 62/128,682, which was filed on Mar. 5, 2015 and entitled "Membrane-Assisted Process and Method of Refining Wet Natural Gas." The complete disclosures of the above applications are hereby incorporated by reference for all purposes.

BACKGROUND OF THE DISCLOSURE

Rich natural gas is a mixture of hydrocarbon compounds that includes methane gas and other hydrocarbon compounds (or other hydrocarbons) heavier than methane gas. Rich natural gas may include methane gas in any concentration, such as 50% or higher. The other hydrocarbon compounds may include any compounds with hydrogen atoms and two or more carbon atoms, such as ethane, propane, butane, isobutene, pentane, propylene, and/or other hydrocarbon compounds. Rich natural gas may be found in crude oil wells, gas wells, condensate wells, and/or other sources. In crude oil wells, the rich natural gas may be dissolved in oil at the high pressures existing in a well and/or as a gas cap above the oil.

The rich natural gas may need to be purified to at least substantially remove or separate the other hydrocarbon compounds from the methane gas before the natural gas is used. The purified or product stream may be used in a variety of applications. One such application is for combustion engines, such as the combustion engines used in commercial engine-driven generators (gensets). The separated other hydrocarbon compounds also may be used in a variety of applications, such as inputs for petrochemical plants, space heating and cooking, and for blending into vehicle fuel.

SUMMARY OF THE DISCLOSURE

Some embodiments may provide a refining assembly for rich natural gas containing a first methane gas and other hydrocarbons that are heavier than methane gas. In some embodiments, the refining assembly may include a methane-producing assembly configured to receive at least one liquid-containing feed stream that includes water and rich natural gas and to produce an output stream therefrom by (a) converting at least a substantial portion of the other hydrocarbons of the rich natural gas with the water to a second methane gas, a lesser portion of the water, and other gases, and (b) allowing at least a substantial portion of the first methane gas from the rich natural gas to pass through the methane-producing assembly unconverted. The refining assembly may additionally include a purification assembly configured to receive the output stream and to produce a methane-rich stream therefrom having a greater methane concentration than the output stream.

In some embodiments, the refining assembly may include a vaporizer configured to receive and vaporize at least a portion of at least one liquid-containing feedstream that includes water and rich natural gas to form an at least substantially vaporized stream. The refining assembly may

additionally include a methane-producing reactor containing a catalyst and configured to receive the vaporized feed stream and to produce an output stream by (a) converting at least a substantial portion of the other hydrocarbons with the water to a second methane gas, a lesser portion of the water, hydrogen gas, and carbon oxide gas, and (b) allowing at least a substantial portion of the first methane gas from the rich natural gas stream to pass through the methane-producing reactor unconverted. The refining assembly may further include a first heating assembly configured to receive at least one fuel stream and at least one air stream and produce a heated exhaust stream for heating at least one of the vaporizer to at least a minimum vaporization temperature or the methane-producing reactor to at least a minimum methane-producing temperature. The refining assembly may additionally include a purification assembly configured to receive the output stream and to produce a methane-rich stream therefrom having a greater methane concentration than the output stream.

Some embodiments may provide a method of refining rich natural gas containing a first methane gas and other hydrocarbons that are heavier than methane gas. In some embodiments, the method may include converting at least a substantial portion of the other hydrocarbons of the rich natural gas with water to an output stream containing a second methane gas, a lesser portion of the water, hydrogen gas, and carbon oxide gas. Converting at least a substantial portion of the other hydrocarbons may include not converting at least a substantial portion of the first methane gas from the rich natural gas. The method may additionally include removing at least a portion of the water from the output stream to produce an at least substantially dried stream therefrom. The method may further include converting at least a portion of the carbon oxide gas and at least a portion of the hydrogen gas from the at least substantially dried stream to methane gas to form an intermediate stream therefrom containing a lower concentration of hydrogen gas and carbon oxide gas compared to the at least substantially dried stream. The method may additionally include separating, from the intermediate stream, at least a portion of the carbon oxide gas to form a byproduct stream therefrom. The remaining portion of the intermediate stream may form at least part of a methane-rich stream having a greater methane concentration than the intermediate stream.

BRIEF DESCRIPTION OF THE DRAWINGS

FIG. 1 is a schematic view of an example of a refining assembly for rich natural gas.

FIG. 2 is a schematic view of an example of a methane-producing assembly of the refining assembly of FIG. 1.

FIGS. 3-5 are schematic views of different configurations for the methane-producing assembly of FIG. 2.

FIG. 6 is a schematic view of an example of a purification assembly of the refining assembly of FIG. 1.

FIG. 7 is a schematic view of an example of a water removal assembly of the purification assembly of FIG. 6.

FIG. 8 is a schematic view of an example of a gas removal assembly of the purification assembly of FIG. 6.

FIGS. 9-10 are schematic views of different configurations for the gas removal assembly of FIG. 8.

FIG. 11 is a schematic view of another example of a gas removal assembly of the purification assembly of FIG. 6.

FIG. 12 is a schematic view of another example of a refining assembly for rich natural gas.

FIG. 13 is a schematic view of an example of a methane-producing assembly of the refining assembly of FIG. 12.

FIG. 14 is a schematic view of an example of a gas removal assembly of the refining assembly of FIG. 12.

FIG. 15 is a schematic view of another example of a gas removal assembly of the refining assembly of FIG. 12.

FIG. 16 is a schematic view of a further example of a gas removal assembly of the refining assembly of FIG. 12.

FIG. 17 is a schematic view of another example of a gas removal assembly of the refining assembly of FIG. 12.

FIG. 18 is a schematic view of a further example of a gas removal assembly of the refining assembly of FIG. 12.

FIG. 19 is a schematic view of another example of a gas removal assembly of the refining assembly of FIG. 12.

FIG. 20 is a schematic view of a membrane contactor of the gas removal assembly of FIG. 19.

FIG. 21 is a schematic view of an example of a membrane of the membrane contactor of FIG. 20.

FIG. 22 is a schematic view of another example of a membrane of the membrane contactor of FIG. 20.

FIG. 23 is a schematic view of a further example of a gas removal assembly of the refining assembly of FIG. 12.

FIG. 24 is a schematic view of another example of a refining assembly for rich natural gas.

FIG. 25 is an example of a plate burner of a heating assembly for a refining assembly.

FIG. 26 is an example of a method of refining rich natural gas.

DETAILED DESCRIPTION OF THE DISCLOSURE

FIG. 1 shows an example of a refining assembly 30 for rich natural gas. Unless specifically excluded refining assembly 30 may include one or more components of other refining assemblies and/or other assemblies described in this disclosure. The refining assembly may include any suitable structure configured to receive at least one rich natural gas stream 32 and generate a product methane stream 34. For example, the refining assembly may include a feedstock delivery system 36 and a fuel processing system 38. The feedstock delivery system may include any suitable structure configured to selectively deliver at least one feed stream 40 (which includes rich natural gas stream 32) to the fuel processing assembly.

In some embodiments, feedstock delivery system 36 may additionally include any suitable structure configured to selectively deliver at least one fuel stream 44 from a fuel source 42 (such as storage cylinder(s) or vessel(s)) to one or more burners and/or other heating assemblies of fuel processing system 38. The feedstock delivery system may include any suitable delivery mechanisms, such as pumps, compressors, and/or other mechanism(s) for propelling fluid streams. In some embodiments, feedstock delivery system 36 may be configured to deliver feed stream(s) 40 and/or fuel stream(s) 44 without requiring the use of pumps, compressors, and/or other electrically powered fluid-delivery mechanisms. In some embodiments, feedstock delivery system may include a heat exchanger and/or other heating device(s) configured to pre-heat or heat one or more streams, such as feed stream(s) 40, prior to fuel processing system 38.

Feed stream 40 may include a methane-production fluid stream 46 and rich natural gas stream 32. The methane-production fluid stream may include at least one methane-production fluid, such as water from a water source 41. Water source 41 may include a connection to publicly available water (e.g., tap water, running water, municipal water, etc.), a storage vessel, a surface water source (e.g., river, lake, etc.), a groundwater source, and/or other

source(s). In some embodiments, water from water source 41 may be deionized prior to delivery as methane-production fluid stream 46. Rich natural gas stream 32 may be from a rich natural gas source 48, such as a well head, a storage vessel, and/or other source(s). When methane-production fluid stream 46 includes liquid water, feed stream 40 may sometimes be referred to as a "liquid-containing feed-stream." The ratio of water to rich natural gas delivered by the feedstock delivery system to the fuel processing system may vary according to one or more factors, such as the amount of carbon in the rich natural gas, user preferences, design of the fuel processing system, mechanism(s) used by the fuel processing system to generate the product methane stream, etc. For example, the molar ratio of water to carbon atoms or steam-to-carbon ratio may be 1:1 to 4:1, preferably 1.5:1 to 3:1, and particularly preferred 1.8:1 to 2.5:1. In some embodiments, the feedstock delivery system may control the flow of methane-production fluid stream 46 and/or rich natural gas stream 32 to provide one or more of the above molar ratios to the fuel processing system.

In some embodiments, rich natural gas stream 32 may be treated in a desulfurization assembly 50 to produce a desulfurized rich natural gas stream 52, such as prior to delivery to fuel processing system 38. Desulfurization assembly 50 may include any suitable structure configured to use any suitable mechanism(s) to at least substantially remove sulfur compounds (e.g., organosulfur compounds, hydrogen sulfides, carbonyl sulfides, and/or other sulfur-containing compounds) from the rich natural gas. For example, desulfurization assembly 50 may include a tower containing an amine solution (e.g., monoethanolamine and diethanolamine) that is configured to absorb sulfur compounds.

Although feedstock delivery system 36 is shown to be configured to deliver a single feed stream 40, the feedstock delivery system may be configured to deliver two or more feed streams 40. Those streams may contain the different compositions, at least one common component, no common components, or the same compositions. For example, feedstock delivery system may be configured to deliver methane-production fluid stream 46 and rich natural gas stream 32 separately into the fuel processing system. Additionally, although feedstock delivery system 36 may, in some embodiments, be configured to deliver a single fuel stream 44, the feedstock delivery system may be configured to deliver two or more fuel streams.

The fuel streams may have different compositions, at least one common component, no common components, or the same compositions. Moreover, the rich natural gas, methane-production fluid, and fuel streams may be discharged from the feedstock delivery system in different phases. For example, one or more of the streams may be liquid stream(s) (such as the water and/or fuel streams) while the one or more of the other streams may be gas streams (such as the rich natural gas stream(s)). Furthermore, although refining assembly 30 is shown to include a single feedstock delivery system 36, the refining assembly may include two or more feedstock delivery systems 36.

Fuel processing system 38 may include any suitable structure configured to process feed stream(s) 40, such as to increase concentration of methane gas and/or reduce concentration of other components in the rich natural gas stream. For example, fuel processing system 38 may include a methane-producing assembly 54 configured to produce an output stream 56 containing methane gas via any suitable methane-producing mechanism(s). The output stream may include methane gas as at least a majority component and may include additional gaseous component(s). Output

5

stream 56 may therefore be referred to as a “mixed gas stream” that contains methane gas as its majority component but which includes water and other gases.

Methane-producing assembly 54 may include any suitable catalyst-containing bed or region. When the methane-producing mechanism is heavy hydrocarbon reforming, the methane-producing assembly may include a suitable heavy hydrocarbon reforming catalyst 58 to facilitate production of output stream(s) 56 from feed stream(s) 40. In such an embodiment, methane-producing assembly 54 may convert at least a substantial portion of other hydrocarbons that are heavier than methane gas with water to methane gas, a lesser portion of the water, and other gases.

Additionally, methane-producing assembly 54 may allow at least a substantial portion of methane gas from rich natural gas stream(s) 32 to pass through the methane-producing assembly unchanged, unreacted, and/or unconverted. In other words, methane gas in output stream 56 may include (1) methane gas in the rich natural gas stream(s) prior to methane-producing assembly 54 and fuel processing system 38, and (2) methane gas that was produced in methane-producing assembly 54 from the conversion of other hydrocarbons in the rich natural gas stream(s) with water. When heavy hydrocarbon reforming is the methane-producing mechanism in methane-producing assembly 54, methane-producing assembly 54 may sometimes be referred to as a “heavy hydrocarbon reformer,” and output stream 56 may sometimes be referred to as a “reformat stream.” The other gases that may be present in the reformat stream may include carbon oxide gas and/or hydrogen gas. As used herein, “carbon oxide gas” refers to carbon dioxide gas and/or carbon monoxide gas.

In some embodiments, fuel processing system 38 may include a purification (or separation) assembly 62, which may include any suitable structure configured to produce at least one methane-rich stream 64 from output (or mixed gas) stream 56. Methane-rich stream 64 may include a greater methane concentration than output stream 56 and/or a reduced concentration of water and one or more other gases (or impurities) that were present in that output stream. Product methane stream 34 includes at least a portion of methane-rich stream 64. Thus, product methane stream 34 and methane-rich stream 64 may be the same stream and have the same composition and flow rates. Alternatively, some of the purified methane gas in methane-rich stream 64 may be stored for later use, such as in a suitable methane storage assembly and/or consumed by the fuel processing system. Purification assembly 62 also may be referred to as a “methane purification device” or a “methane processing assembly.”

In some embodiments, purification assembly 62 may produce one or more streams 66 other than methane-rich stream 64. For example, purification assembly 62 may produce at least one reclaimed water stream 68, which may be at least substantially liquid water. The reclaimed water stream may be discharged to drain, stored for later use, deionized, sent to feedstock delivery system 36 (such as to supplement water source 41), and/or otherwise utilized, stored, and/or disposed. Additionally, purification assembly 62 may produce the reclaimed water stream as a continuous stream responsive to the delivery of output stream 56, or may produce that stream intermittently, such as in a batch process or when the water portion of the output stream is retained at least temporarily in the purification assembly.

Additionally, purification assembly 62 may produce at least one byproduct stream 70, which may contain no methane gas or some methane gas. The byproduct stream

6

may be exhausted, sent to a burner assembly and/or other combustion source, sent to feedstock delivery system 36 (such as to supplement fuel source 42), stored for later use, and/or otherwise utilized, stored, and/or disposed. Additionally, purification assembly 62 may produce the byproduct stream as a continuous stream responsive to the delivery of output stream 56, or may produce that stream intermittently, such as in a batch process or when the byproduct portion of the output stream is retained at least temporarily in the purification region.

Fuel processing system 38 may include one or more purification assemblies 62 configured to produce one or more reclaimed water streams and/or one or more byproduct streams. The byproduct streams 70 may contain sufficient amounts of methane gas and/or other flammable/combustible gases to be suitable for use as a fuel stream, such as for one or more heating assemblies of the fuel processing system. In some embodiments, the byproduct stream may have sufficient fuel value or methane content to enable one or more heating assemblies to maintain the methane-producing assembly at a desired operating temperature or within a selected range of temperatures, and/or to maintain one or more assemblies in purification assemblies 62 at a predetermined operating temperature or within a predetermined range of temperatures.

Purification assembly 62 may include any suitable structure configured to enrich (and/or increase) the concentration of at least one component of output stream 56. In most applications, methane-rich stream 64 will have a greater methane concentration than output stream (or mixed gas stream) 56. The methane-rich stream may alternatively, or additionally, have a reduced concentration of one or more non-methane components that were present in output stream 56 with the methane concentration of the methane-rich stream being more, the same, or less than the output stream.

Examples of suitable devices for purification assembly 62 include gas dryers 72 and/or water knockout devices 74, which may additionally produce reclaimed water stream(s) 68. Other examples of suitable devices for purification assembly include one or more synthetic natural gas (SNG) reactors 76, scrubbers 78, carbon oxide-selective membranes 80, and/or membrane contactors 82, which may additionally produce byproduct stream(s) 70. Purification assembly 62 may include more than one type of purification device and the devices may have the same or different structures and/or operate by the same or different mechanism(s). For example, purification assembly 62 may include multiple gas dryers 72 and/or water knockout devices 74. In some examples, a water knockout device 74 and/or a gas dryer 72 may be upstream one or more of the other devices in purification assembly 62. For example, purification assembly 62 may include a water knockout device 74 and/or a gas dryer 72 upstream each SNG reactor 76, scrubber 78, carbon oxide-selective membrane 80, and/or membrane contactor 82.

Gas dryers 72 may include devices that are capable of selectively removing water vapor from a gas stream. Examples of gas dryers 72 include water-selective membranes, desiccant beds, refrigeration dryers, and/or other devices for removing water vapor from gases. An example of a suitable refrigeration dryer is the Drypoint® RA series sold by Beko or the SPL series sold by Parker. Water knockout devices 74 may include devices that separate out liquid water (e.g., entrained liquid water), such as coalescing filters. SNG reactors 76 may convert carbon oxide gas (such as carbon dioxide gas and/or carbon monoxide gas) and hydrogen gas to produce methane gas and water. In some

embodiments, SNG reactors **76** may cause hydrogen to react primarily with carbon dioxide gas, and secondarily with carbon monoxide gas.

Scrubbers **78** may receive at least one absorbent that is adapted to absorb carbon oxide gas and/or hydrogen gas. The scrubbers may include an absorber (or absorber portion) configured to direct the flow of the gas stream with carbon oxide and/or hydrogen gas through the at least one absorbent that is adapted to absorb the carbon oxide gas and/or hydrogen gas from that gas stream. The absorbent may be a liquid and/or solid. In some embodiments, scrubbers **78** may include a stripper (or stripper portion) downstream from the absorber portion. The stripper may be configured to strip and/or remove at least a substantial portion of the carbon oxide gas and/or hydrogen gas from the absorbent.

Carbon oxide-selective membranes **80** may be permeable to carbon oxide gas and/or hydrogen gas, but are at least substantially (if not completely) impermeable to methane in output stream **56**. Membranes **80** may be formed of any carbon oxide-permeable and/or hydrogen-permeable material suitable for use in the operating environment and parameters in which purification assembly **62** is operated. Examples of suitable materials for membranes **80** include cellulose acetate, polyimide, polysulfone, and poly(amido-amine) doped poly(ethylene glycol).

Membrane contactors **82** may include devices that include carbon oxide-selective membranes to separate carbon oxide gas and/or hydrogen gas, and a liquid absorbent adapted to absorb carbon oxide gas and/or hydrogen gas. For example, a permeate side of the carbon oxide-selective membranes may receive liquid absorbent. Carbon oxide gas and/or hydrogen gas may pass from a feed side to the permeate side, and then may be absorbed by the liquid absorbent. The membranes may provide a stable interface to allow gas-liquid contacting over a large total surface area without foaming, large gas contacting columns, etc.

Methane-producing assembly **54** and/or purification assembly **62** may each be contained within an assembly housing or assembly shell **84**. In some embodiments, purification assembly **62** may include separate assembly housings or assembly shells **84** for each component or set of components. For example, when purification assembly **62** includes one or more SNG reactors **76**, those reactors may be contained within an assembly housing or an assembly shell **84** separate from other components or assemblies of purification assembly **62**. Those other components also may be contained in separate assembly housings or assembly shells **84**. Assembly shell **84** may include insulating material **86**, such as a solid insulating material, blanket insulating material, and/or an air-filled cavity. The insulating material may be internal the shell, external the shell, or both. When the insulating material is external a shell, fuel processing system **38** may further include an outer cover or jacket **88** external the insulation, as schematically illustrated in FIG. 1.

Fuel processing system **38** may additionally include a frame **90** that supports methane-producing assembly **54** and/or purification assembly **62**. In some embodiments, the methane-producing assembly and/or the purification assembly may additionally be contained within a system housing or system shell **92**. Frame **90** and/or system shell **92** may enable components of fuel processing system to be moved as a unit. The shell also may protect components of the fuel processing system from damage by providing a protective enclosure. In some embodiments, system shell **92** may include insulating material and/or an outer cover or jacket. The fuel processing system may include a different system frame and/or system shell that includes additional compo-

nents of the refining assembly, such as feedstock delivery system **36** and/or other components.

One or more components of fuel processing system **38** may either extend beyond the frame and/or system shell or be located external the frame and/or system shell. For example, one or more components and/or assemblies of purification assembly **62** may be located external the frame and/or system shell, such as being spaced-away from the shell but in fluid communication by suitable fluid-transfer conduits. As another example, a portion of methane-producing assembly **54** may extend beyond the shell, such as indicated schematically with a dashed line representing an alternative shell configuration in FIG. 1.

An example of a methane-producing assembly **54** is shown in FIG. 2, which is generally indicated at **94**. Unless specifically excluded, methane-producing assembly **94** may include one or more components of other methane-producing assemblies and/or other assemblies described in this disclosure. Methane-producing assembly **94** may include at least one vaporizing region or vaporizer **96**, at least one methane-producing region or reactor **98**, and at least one heating assembly **100**.

Vaporizer **96** may include any suitable structure configured to receive and vaporize at least a portion of a liquid-containing feedstream, such as feed stream(s) **40** that include water and rich natural gas, into one or more vapor feed streams **104** (such as one or more at least substantially vaporized streams). Feed stream(s) **40** may have a pressure of <500 psig, and preferably between 20 psig and 100 psig or between 40 psig and 200 psig. In vaporizer **96**, at least a substantial portion of liquid water in feed stream(s) **40** may be vaporized into water vapor, which may mix with the rich natural gas in the feed stream(s). The vaporized feed streams may, in some embodiments, include liquid(s). An example of a suitable vaporizer is a coiled tube vaporizer, such as a coiled stainless steel tube.

Methane-producing reactor **98** may include any suitable structure configured to receive one or more feed streams, such as vapor feed streams **104** from vaporizer **96**, to produce one or more output streams **56** containing methane as a majority component, water, and other gases. The methane-producing reactor may produce the output stream via any suitable mechanism(s). For example, methane-producing reactor **98** may generate output stream **56** via a heavy hydrocarbon reforming (HHR) reaction. When methane-producing reactor **98** generates output stream **56** via a HHR reaction, that reactor may sometimes be referred to as a "heavy hydrocarbon reforming reactor" or a "HHR reactor."

Methane-producing reactor **98** may have any suitable design, such as a tubular or cylindrical design. Additionally, methane-producing reactor **98** may include any suitable catalyst-containing bed or region to accelerate chemical reaction or conversion rates. When the methane-producing mechanism is HHR, the methane-producing reactor may include a suitable HHR catalyst **108** to facilitate production of output stream(s) **56** from vapor feed stream(s) **104**. Examples of suitable HHR catalysts include nickel-based catalysts (such as Reformax® 100-RS and HyProGen® R-70, both sold by Clariant®, Louisville, Ky.; and MC-750R sold by Unicat, Houston, Tex.) and ruthenium-based catalysts (such as M-10 sold by Clariant®, Louisville, Ky.).

Methane-producing reactor **98** may be configured to convert at least a substantial portion of hydrocarbon compounds heavier than methane gas in the vapor feed stream with the water in that stream to methane gas, a lesser portion of the water, and other gases. Additionally, methane-producing

reactor **98** may be configured to allow at least a substantial portion of the methane gas in vapor feed stream **104** to pass through the methane-producing reactor unconverted, unchanged, and/or unreacted. As an example, methane-producing reactor **98** may be configured to convert propane in the vapor feed stream with the water in that stream to methane gas, carbon oxides, hydrogen, and water as shown in the approximate chemical reaction below.

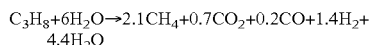

The above equation is only an example and does not represent all the conversions and/or reactions that may occur in the methane-producing reactor, such as when vapor feed stream **104** includes hydrocarbon compounds heavier than methane gas other than propane.

Methane-producing assembly **94** also may include a temperature modulating assembly in the form of heating assembly **100**. The heating assembly may be configured to produce at least one heated exhaust stream (or combustion stream) **110** from at least one heating fuel stream **112**, typically as combusted in the presence of air. Heated exhaust stream **110** is schematically illustrated in FIG. **2** as heating vaporizer **96** and methane-producing reactor **98**. Heating assembly **100** may include any suitable structure configured to generate the heated exhaust stream(s), such as a burner or combustion catalyst in which a fuel is combusted with air to produce the heated exhaust stream. The heating assembly may include an ignitor or ignition source **114** that is configured to initiate the combustion of fuel. Examples of suitable ignition sources include one or more spark plugs, glow plugs, combustion catalyst, pilot lights, piezoelectric ignitors, spark igniters, hot surface igniters, etc.

Heating assembly **100** may achieve and/or maintain in vaporizer **96** and/or methane-producing reactor **98** any suitable temperatures. For example, heating assembly **100** may heat vaporizer **96** to at least a minimum vaporization temperature, and/or may heat methane-producing reactor **98** to at least a minimum methane-producing temperature. HHR reactors may operate at temperatures in the range of 200° C. to 600° C., preferably 250° C. to 500° C., and more preferably 390° C. to 470° C. The above temperature ranges are much lower than the temperature ranges for steam reforming methane, which typically is about 800° C. to 900° C.

In some embodiments, heating assembly **100** may include a burner assembly **116** and may be referred to as a combustion-based, or combustion-driven, heating assembly. In a combustion-based heating assembly, heating assembly **100** may be configured to receive at least one fuel stream **112** and to combust the fuel stream in the presence of air to provide a hot combustion stream **110** that may be used to heat the vaporizer and/or methane-producing reactor. Air may be delivered to the heating assembly via a variety of mechanisms. For example, an air stream **118** may be delivered to the heating assembly as a separate stream, as shown in FIG. **2**. Alternatively, or additionally, air stream **118** may be delivered to the heating assembly with at least one of the fuel streams **112** for heating assembly **100** and/or drawn from the environment within which the heating assembly is utilized.

Fuel stream **112** may include any combustible liquid(s) and/or gas(es) that are suitable for being consumed by heating assembly **100** to provide the desired heat output. In some embodiments, one or more fuel stream(s) **112** may be delivered to the heating assembly via feedstock delivery system **36**. Some fuel streams may be gases when delivered and combusted by heating assembly **100**, while others may

be delivered to the heating assembly as a liquid stream. Examples of suitable heating fuels for fuel streams **112** include carbon-containing feedstocks, such as methanol, methane, ethane, ethanol, ethylene, propane, propylene, butane, etc. Additional examples include low molecular weight condensable fuels, such as liquefied petroleum gas, ammonia, lightweight amines, dimethyl ether, and low molecular weight hydrocarbons. Yet other examples include hydrogen gas and/or carbon oxide gas. For example, one or more byproduct streams **120** from other components and/or assemblies of the fuel processing system may be used as a suitable heating fuel for fuel stream(s) **112**.

Combustion stream **110** may additionally, or alternatively, be used to heat other portions of the fuel processing system and/or other systems with which the heating assembly is used. After combustion stream **110** heats vaporizer **96**, methane-producing reactor **98**, and/or other components and assemblies, the stream may exit as combustion exhaust stream(s) **122**.

Additionally, other configuration and types of heating assemblies **100** may be used. For example, heating assembly **100** may be an electrically powered heating assembly that is configured to heat vaporizer **96** and/or methane-producing reactor **98** by generating heat using at least one heating element (such as a resistive heating element), waste heat stream(s), solar heating, etc. In those embodiments, heating assembly **100** may not receive and combust a combustible fuel stream to heat vaporizer to a suitable vaporization temperature and/or heat methane-producing reactor to a suitable methane-producing temperature. Examples of heating assemblies are disclosed in U.S. Pat. No. 7,632,322, the complete disclosure of which is hereby incorporated by reference for all purposes.

The heating assembly also may be configured to heat other components and/or assemblies, such as a feedstock delivery system, the feedstock supply streams, purification assemblies, or any suitable combination of those systems, streams, and regions. The heating assembly may additionally be configured to heat other components of the refining assembly. For example, the heated exhaust stream may be configured to heat a pressure vessel and/or other canister containing the heating fuel and/or the hydrogen-production fluid that forms at least portions of feed stream(s) **40** and fuel stream(s) **112**.

Heating assembly **100** may be housed in an assembly shell or housing **124** with the vaporizer and/or methane-producing reactor. The heating assembly may be separately positioned relative to the vaporizer and/or methane-producing reactor but in thermal and/or fluid communication with those components to provide the desired heating. Heating assembly **100** may be located partially or completely within the common shell, and/or at least a portion (or all) of the heating assembly may be located external that shell. When the heating assembly is located external the shell, the hot combustion gases from burner assembly **116** may be delivered via suitable heat transfer conduits to one or more components within the shell.

Although methane-producing assembly **94** is shown to include a single vaporizer **96**, a single methane-producing reactor **98**, and a single heating assembly **100**, the methane-producing assembly may include two or more vaporizers **96**, two or more methane-producing reactors **98**, and/or two or more heating assemblies **100**, as shown in dashed lines in FIG. **2**.

Vaporizer **96**, methane-producing reactor **98**, and heating assembly **100** may be arranged in any suitable configuration. Examples of suitable configurations are shown in FIGS. **3-5**.

11

In FIG. 3, vaporizer 96 is disposed between methane-producing reactor 98 and heating assembly 100. In FIG. 4, vaporizer 96 and methane-producing reactor 98 are side-by-side with heating assembly 100 below the vaporizer and methane-producing reactor. In FIG. 5, vaporizer 96 and methane-producing reactor 98 are side-by-side with heating assembly 100 spaced from and adjacent to vaporizer 96.

An example of a purification assembly 62 is shown in FIG. 6, which is generally indicated at 126. Unless specifically excluded, purification assembly 126 may include one or more components of other purification assemblies described in this disclosure. Purification assembly 126 may include at least one water removal assembly 128 and at least one gas removal assembly 130.

Water removal assembly 128 may include any suitable structure configured to remove water from output stream 56 of methane-producing assembly 54 (or an intermediate stream 132) to produce an at least substantially dried stream 134 (such as an at least substantially dried output stream). The water removed by the water removal assembly may be in the form of water vapor and/or liquid water. Water removal assembly 128 may produce one or more reclaimed water streams 135 from the water removed from output stream 56 and/or intermediate stream 132. The reclaimed water may be pumped or otherwise transported to a feed-stock delivery system for use in the methane-producing assembly and/or may be stored, sent to drain, or otherwise disposed.

Gas removal assembly 130 may include any suitable structure configured to remove one or more other gases (such as gases other than methane gas) from at least substantially dried stream 134 to form methane-rich stream 64. For example, gas removal assembly 130 may be configured to remove carbon oxide gas and/or hydrogen gas from at least substantially dried stream 134. When purification assembly 126 includes two or more gas removal assemblies 130, one or more upstream gas removal assemblies may remove one or more other gases from at least substantially dried stream 134 to form one or more intermediate streams 138. Gas removal assembly(ies) 130 may produce one or more byproduct streams 140 from the removed gases, such as carbon oxide gas and hydrogen gas. The byproduct streams may be pumped or otherwise transported to feed-stock delivery system 36 and/or one or more heating assemblies to burn as fuel, and/or may be stored, discharged, or otherwise disposed.

In some embodiments, gas removal assembly 130 may include a carbon oxide-selective membrane assembly having one or more carbon oxide-selective membranes 141. The carbon oxide-selective membranes may include any suitable structure configured to remove carbon oxide gas and/or hydrogen gas from at least substantially dried stream(s) 134 and/or intermediate stream(s) 138. Carbon oxide-selective membranes 141 may have a relatively high permeability to carbon oxide gas and/or hydrogen gas over methane gas such that dried output stream 134 and/or intermediate stream 138, when passed through one or more of the carbon oxide-selective membranes, would be preferentially depleted of at least a portion of carbon oxide gas and/or hydrogen gas. The carbon oxide gas and/or hydrogen gas may form byproduct stream(s) 140. Examples of suitable carbon oxide-selective membranes include cellulose acetate (from UOP), polyimide and polysulfone (from Air Products and Membrane Technology and Research, Inc.), and poly(amidoamine) doped poly(ethylene glycol) (from Kyushu University, Japan).

12

When gas removal assembly 130 includes one or more carbon oxide-selective membranes 141, at least substantially dried stream 134 and/or intermediate stream 138 may be at a pressure greater than 40 psig, and preferably greater than 80 psig. Gas removal assembly 130 may include one or more pumps or compressors to provide streams 134 and/or 138 at the pressures described above to the carbon oxide-selective membranes. Methane-rich stream(s) 64 and/or intermediate stream(s) 138 exiting the carbon oxide-selective membranes may contain less than 5% of carbon dioxide, and preferably less than 3% of carbon dioxide.

Purification assembly 126 may include any suitable number of water removal assemblies 128 and/or any suitable number of gas removal assemblies 130, as shown in the dashed boxes in FIG. 6. When the purification assembly includes two or more water removal assemblies 128, those assemblies may be the same or different from each other. Additionally, when the purification assembly includes two or more gas removal assemblies 130, those assemblies may be the same or different from each other. For example, one or more gas assemblies 130 may be configured to remove one or more other gases via a first mechanism, while one or more other gas assemblies 130 may be configured to remove one or more other gases via a second mechanism that is different from the first mechanism.

Moreover, when there are two or more gas assemblies, those assemblies may remove different types of other gases and/or remove those gases in different proportions. Furthermore, the water removal assemblies and gas assemblies may be in any suitable sequence or order. In some embodiments, purification assembly 126 may include a water removal assembly 128 upstream of one or more gas removal assemblies 130. For example, purification assembly 126 may include a water removal assembly, a first gas removal assembly, and a second gas removal assembly. In some embodiments, purification assembly 126 may include a water removal assembly 128 upstream each gas removal assembly 130. For example, purification assembly 126 may include a first water removal assembly, a first gas removal assembly, a second water removal assembly, and a second gas removal assembly.

An example of a water removal assembly 128 is shown in FIG. 7, which is generally indicated at 142. Unless specifically excluded, water removal assembly 142 may include one or more components of other water removal assemblies and/or other assemblies described in this disclosure. Water removal assembly 142 may include at least one gas dryer 144, which may include any suitable structure configured to remove at least a substantial portion of water vapor from one or more streams 146, such as an output stream from a methane-producing assembly or an intermediate stream from an upstream gas removal assembly, to form an at least substantially dried stream 148. For example, gas dryer 144 may include one or more water-selective membranes, desiccant beds, refrigerant dryers, and/or other devices. Gas dryer 144 is preferred to include one or more refrigerant dryers, such as the Drypoint® RA series sold by Beko and SPL series sold by Parker.

In some embodiments, water removal assembly 142 may include at least one water knockout device 150 configured to remove at least a substantial portion of liquid water from stream 146. For example, when entrained liquid water is present in output stream(s) 146 in addition to water vapor, the water removal assembly may include one or more water knockout devices 150. Water removal assembly 142 may produce one or more reclaimed water streams 135 from the water vapor and/or liquid water removed from stream(s)

13

146. The reclaimed water streams may be discharged, pumped or otherwise transported to a feedstock delivery system, and/or stored, sent to drain, or otherwise disposed.

An example of a gas removal assembly 130 is shown in FIG. 8, which is generally indicated at 154. Unless specifically excluded, gas removal assembly 154 may include one or more components of other gas removal assemblies described in this disclosure. Gas removal assembly 154 may include at least one gas removal region or reactor 156 and at least one heating assembly 158.

Gas removal reactor 156 may include any suitable structure configured to receive one or more feed streams, such as an at least substantially dried stream 160 (e.g., at least substantially dried stream 134) from water removal assembly 128, to produce one or more intermediate streams 162 or one or more methane-rich streams 64 containing a lower concentration of carbon oxide gas and hydrogen gas and/or a higher concentration of methane gas compared to the at least substantially dried stream(s). The gas removal reactor may produce the intermediate and/or methane-rich stream(s) via any suitable mechanism(s). For example, gas removal reactor 156 may generate those streams via a methanation reaction. When gas removal reactor 156 generates intermediate stream 162 and/or methane-rich stream 64 via a methanation reaction, that reactor may sometimes be referred to as a "methanation reactor," "synthetic natural gas reactor" or "SNG reactor."

The SNG reactor(s) may be operated between 250° C. and 450° C., and preferably between 290° C. and 380° C. Additionally, the operating pressure of the SNG reactor may be similar to the operating pressure of the HHR reactor, such as with only a minimal pressure drop between the HHR reactor and the SNG reactor. For example, the HHR reactor may operate between 20 psig to 100 psig and the SNG reactor may operate between 18 psig to 98 psig, which assumes a 2 psig pressure drop (reduction) due to components located between the two reactors (such as the heat exchanger and the gas dryer).

Gas removal reactor 156 may have any suitable design, such as a tubular or cylindrical design. Additionally, gas removal reactor 156 may include any suitable catalyst-containing bed or region to accelerate chemical reaction or conversion rates. When the gas removal mechanism is methanation, the gas removal reactor may include a suitable methanation catalyst 166 to facilitate production of intermediate stream(s) 162 and/or methane-rich stream(s) 64 from at least substantially dried stream(s) 160. Examples of suitable methanation catalysts include nickel-based catalysts (such as Reformax® RS-100 and HyProGen® R-70, both sold by Clariant, Louisville, Ky.; and MC-750R sold by Unicat, Houston, Tex.) and ruthenium-based catalysts (such as M-10 sold by Clariant, Louisville, Ky.).

Gas removal reactor 156 may be configured to convert a portion of carbon oxide gas and/or a portion of hydrogen gas in at least substantially dried stream 160 to methane gas and water. As an example, gas removal reactor 156 may be configured to convert carbon dioxide gas and hydrogen gas to methane gas and water as shown in the approximate chemical reaction below.

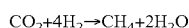

As another example, gas removal reactor 156 may be configured to convert carbon monoxide gas and hydrogen gas to methane gas and water as shown in the approximate chemical reaction below.

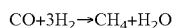

14

The above equations are only examples and do not represent all the conversions and/or reactions that may occur in the gas removal reactor.

Gas removal assembly 156 may include two or more gas removal reactors 156, such as in series, to remove carbon oxide gas and/or hydrogen gas. In some embodiments, a water removal assembly may be upstream one or more gas removal reactors 156. In some embodiments, a water removal assembly may be upstream each gas removal reactor 156.

Gas removal assembly 154 also may include a temperature modulating assembly in the form of heating assembly 158. The heating assembly may be configured to produce at least one heated exhaust stream (or combustion stream) 168 from at least one heating fuel stream 170, typically as combusted in the presence of air. Heated exhaust stream 168 is schematically illustrated in FIG. 8 as heating gas removal reactor 156. Heating assembly 158 may include any suitable structure configured to generate the heated exhaust stream, such as a burner or combustion catalyst in which a fuel is combusted with air to produce the heated exhaust stream. The heating assembly may include an ignitor or ignition source 172 that is configured to initiate the combustion of fuel.

Heating assembly 158 may achieve and/or maintain any suitable temperatures in gas removal reactor 156. For example, heating assembly 158 may heat the gas removal reactor to at least a target operating temperature and/or at least a minimum conversion temperature. When gas removal reactor 156 removes gases via a methanation reaction (which is an exothermic reaction), the heat assembly may initially heat gas removal reactor to a target operating temperature and then only as necessary to maintain the gas removal reactor at a target operating temperature (such as because of heat loss, etc.).

In some embodiments, heating assembly 158 may include a burner assembly 174 and may be configured to receive at least one fuel stream 170 and to combust the fuel stream in the presence of air to provide one or more hot combustion streams 168 that may be used to heat the gas removal reactor. Air may be delivered to the heating assembly via a variety of mechanisms. For example, at least one air stream 176 may be delivered to the heating assembly as a separate stream, as shown in FIG. 8. Alternatively, or additionally, air stream 176 may be delivered to the heating assembly with at least one of the fuel streams 170 for heating assembly 158 and/or drawn from the environment within which the heating assembly is utilized.

Fuel stream 170 may include any combustible liquid(s) and/or gas(es) that are suitable for being consumed by heating assembly 158 to provide the desired heat output. In some embodiments, feedstock delivery system 36 may provide one or more fuel streams 170. Some fuel streams may be gases when delivered and combusted by heating assembly 158, while others may be delivered to the heating assembly as a liquid stream. Examples of suitable heating fuels for fuel streams 158 include carbon-containing feedstocks, low molecular weight condensable fuels, and low molecular weight hydrocarbons. Other examples include hydrogen gas and carbon oxide gas from byproduct stream(s) 178s. For example, one or more byproduct streams 178 from other components and/or assemblies of the fuel processing system may be used as a suitable heating fuel for fuel stream(s) 170.

Combustion stream(s) 168 may additionally, or alternatively, be used to heat other portions of the fuel processing system and/or other systems with which the heating assem-

15

bly is used. After combustion stream **168** heats gas removal reactor **156** and/or other components and assemblies, the stream(s) may exit as combustion exhaust stream(s) **180**.

Additionally, other configurations and types of heating assemblies **158** may be used. For example, heating assembly **158** may be an electrically powered heating assembly that is configured to heat gas removal reactor **156** by generating heat using at least one heating element (such as a resistive heating element), waste heat stream(s), solar heating, etc. In those embodiments, heating assembly **158** may not receive and combust a combustible fuel stream to heat gas removal reactor **156** to a suitable gas-removal temperature.

The heating assembly also may be configured to heat other components and/or assemblies, such as the feedstock delivery system, the feedstock supply streams, methane-producing assemblies, and/or other assemblies of the purification assembly, or any suitable combination of those systems, streams, and regions. The heating assembly may additionally be configured to heat other components of the refining assembly. For example, the heated exhaust stream may be configured to heat a pressure vessel and/or other canister containing the heating fuel and/or the hydrogen-production fluid that forms at least portions of the feed stream(s) and/or fuel stream(s).

Heating assembly **158** may be housed in an assembly shell or housing with the gas removal reactor. The heating assembly may be separately positioned relative to the gas removal reactor but in thermal and/or fluid communication with that component to provide the desired heating. Heating assembly **158** may be located partially or completely within the common shell, and/or at least a portion (or all) of the heating assembly may be located external that shell. When the heating assembly is located external the shell, the hot combustion gases from burner assembly **174** may be delivered via suitable heat transfer conduits to one or more components within the shell.

Although gas removal assembly **154** and methane-producing assembly **94** (in FIG. 2) are shown to each include a heating assembly, the gas removal and methane-producing assemblies may have a common heating assembly that may be located within the shell of the methane-producing assembly, within the shell of the gas removal assembly, or outside one or both those shells. When there is a common heating assembly between the gas removal assembly and the methane-producing assembly, the heating assembly may include suitable heat transfer conduits to transfer heat to the components of the gas removal and/or methane-producing assemblies. Additionally, when gas removal assembly **154** includes two or more gas removal reactors **156**, the gas removal assembly may include a common heating assembly **158** for two or more of the gas removal reactors (and, in some embodiments, for all of the gas removal reactors). Moreover, although gas removal assembly **154** is shown to include a single gas removal reactor **156** and a single heating assembly **158**, the gas removal assembly may include two or more gas removal reactors **156** and/or two or more heating assemblies **158**, as shown in dashed lines in FIG. 8.

Gas removal reactor **156** and heating assembly **158** may be arranged in any suitable configuration. Examples of suitable configurations are shown in FIGS. 9-10. In FIG. 9, gas removal reactor **156** is disposed above heating assembly **158**. In FIG. 10, heating assembly **158** is spaced from and adjacent to gas removal reactor **156**.

Another example of a gas removal assembly **130** is shown in FIG. 11, which is generally indicated at **184**. Unless specifically excluded, gas removal assembly **184** may include one or more components of other gas removal

16

assemblies described in this disclosure. Gas removal assembly **184** may include at least one gas separation assembly **186**.

Gas separation assembly **186** may include any suitable structure configured to separate carbon oxide gas and/or hydrogen gas from an at least substantially dried stream **188** (such as from an upstream water removal assembly) and/or from an intermediate stream **189** (such as from an upstream gas removal reactor) to produce a methane-rich stream **190** (e.g., methane-rich stream **64**), or intermediate stream **192** if there are additional gas removal assemblies downstream, having a reduced concentration of carbon oxide gas and/or hydrogen gas and/or an increased concentration of methane gas compared to streams **188** and/or **189**. For example, gas separation assembly **186** may include at least one absorber **194** configured to receive at least one chemical agent or absorbent **196** that is adapted to absorb at least a portion of carbon oxide gas and/or hydrogen gas from at least substantially dried stream **190** and/or from intermediate stream **192**.

The absorber is configured to receive absorbent **196** and direct flow of streams **188** and/or **189** through the absorbent to absorb carbon oxide gas and/or hydrogen gas from those streams. As used herein, "absorb" means that carbon oxide gas and/or hydrogen gas is bound to or fixed by the absorbent through a reversible or irreversible process, and the bound carbon oxide gas and/or hydrogen gas may involve surface interactions with the absorbent, bulk interactions with the absorbent, or both. Absorbent **196** may be in liquid form, in solid form, or a combination. Suitable examples of absorbents for carbon oxide include any chemical or mix of chemicals that bind carbon oxide, such as metal hydroxides (e.g., sodium hydroxide, potassium hydroxide, calcium hydroxide, magnesium hydroxide, etc.); metal oxides (e.g., sodium oxide, potassium oxide, calcium oxide, magnesium oxide, iron oxide, etc.); organic amines, especially alkanolamines (e.g., monoethanolamine and diethanolamine, both liquids under normal conditions of temperature and pressure); aqueous solutions of metal hydroxides; Ascarite® (Thomas Scientific), CarboLime™ (Allied Health Products Inc.), and SodaLime (Airgas Corp.); immobilized organic amines (such as organic amines bound to polymeric substrates, especially polymeric beads); and mixtures of the above chemical agents.

Methane-rich stream **190** (or intermediate stream **192**) leaving absorber **194** may include a reduced concentration of carbon oxide gas and/or hydrogen gas and/or an increased concentration of methane gas compared to at least substantially dried stream **188** and/or intermediate stream **189**. Preferably, the methane-rich stream includes less than 5% carbon dioxide. Absorber **194** may be operated at a pressure of less than 100 psig, and preferably at a pressure that is between 10 psig and 50 psig.

When absorbent **196** is in solid form, absorber **194** may include two or more absorbent beds **197** and may be configured to direct flow of streams **188** and/or **189** to a first bed of those absorbent beds. When that bed is nearly saturated with carbon oxide gas and/or hydrogen gas, the absorber may be configured to direct flow to another bed of the absorbent beds to allow the absorbent of the previous absorbent bed to be recharged and/or regenerated. When absorbent **196** is in liquid form, the absorbent may be configured to absorb or bind carbon oxide gas and/or hydrogen gas at relatively low temperatures and then release or desorb the gas(es) at elevated temperatures.

Gas separation assembly **186** may alternatively, or additionally, include a membrane contactor assembly **198** that may include one or more permeable membranes **200** (such

17

as one or more carbon oxide-selective membranes). The membrane contactor assembly **198** may be configured to separate carbon oxide gas and/or hydrogen gas from at least substantially dried stream **188** and/or from intermediate stream **189**. For example, permeable membranes **200** may have relatively high permeability to carbon oxide gas and/or hydrogen gas relative to methane gas allowing carbon oxide gas and/or hydrogen from streams **190** and/or **192** to pass from a feed side to a permeate side of the permeable membranes.

Membrane contactor assembly **198** may additionally be configured to receive at least one liquid chemical agent or liquid absorbent **202** that is adapted to absorb at least a portion of carbon oxide gas and/or hydrogen gas from the carbon oxide gas and/or hydrogen gas separated from streams **188** and/or **189** (such as the carbon oxide gas and/or hydrogen gas that passes from the feed side to the permeate side of the permeable membranes). For example, the membrane contactor assembly may receive the absorbent on the permeate side of permeable membranes **200**. Liquid absorbent **202** may be configured to absorb or bind carbon oxide gas and/or hydrogen gas at relatively low temperatures and then release or desorb the gas(es) at elevated temperatures. Examples of suitable liquid absorbents include alkanolamines, such as monoethanolamine or diethanolamine, or water solutions thereof. However, other organic amines, solutions of organic amines, or solutions of inorganic hydroxide salts and/or organic hydroxide salts may be used.

When gas separation assembly **186** includes absorber(s) **194** and/or permeable membrane(s) **200** that receive a liquid absorbent, the gas separation assembly may produce at least one liquid absorbent stream **204** having absorbed carbon oxide gas and/or hydrogen gas (which also may be referred to as "spent liquid absorbent stream(s)" or "gas laden liquid absorbent stream(s).") When spent liquid absorbent stream **204** is produced and the absorption of gas(es) in that stream is reversible, gas removal assembly **184** may additionally include at least one gas extraction assembly **206**.

Gas extraction assembly **206** may include any suitable structure configured to extract (or desorb) the absorbed gases from liquid absorbent stream(s) **204**. For example, gas extraction assembly **206** may include one or more strippers **208**. In some embodiments, when the liquid absorbent includes absorbed carbon oxide gas and/or hydrogen gas, the gas extraction assembly may be configured to extract or desorb at least a substantial portion of the absorbed carbon oxide gas and/or hydrogen gas to form an at least substantially regenerated liquid absorbent stream (or stripped liquid absorbent stream) **210** with at least a substantial portion of the carbon oxide gas and/or hydrogen gas extracted, and an offgas stream **212** with the extracted carbon oxide gas and/or hydrogen gas.

Stripped liquid absorbent stream **210** may be pumped or otherwise transported to gas separation assembly **186** to further absorb carbon oxide gas and/or hydrogen gas from streams **190** and/or **192**. Alternatively, or additionally, stripped liquid absorbent stream **210** may be stored for later use. Offgas stream **212** may be pumped or otherwise transported to one or more other components of the refining assembly, such as to supplement one or more heating fuel streams. Alternatively, offgas stream **212** may be stored, exhausted into the air, or otherwise disposed.

Gas extraction assembly **206** may use any suitable mechanism to regenerate liquid absorbent stream **204** having the absorbed gases. When the liquid absorbent used in gas separation assembly **186** is configured to absorb or bind carbon oxide gas and/or hydrogen gas at relatively low

18

temperatures and then release or desorb the gas(es) at elevated temperatures, gas removal assembly **184** may further include at least one heating assembly **214**. The heating assembly may be configured to produce at least one heated exhaust stream (or combustion stream) **216** from at least one heating fuel stream **218**, typically as combusted in the presence of air. Heated exhaust stream **216** is schematically illustrated in FIG. **11** as heating gas extraction assembly **206**. The heated exhaust stream may alternatively, or additionally, heat spent liquid absorbent stream **204** prior to gas extraction assembly **206**, as shown in FIG. **11**.

Heating assembly **214** may include any suitable structure configured to generate the heated exhaust stream(s), such as a burner or combustion catalyst in which a fuel is combusted with air to produce the heated exhaust stream(s). The heating assembly may include an ignitor or ignition source **220** that is configured to initiate the combustion of fuel. Heating assembly **214** may achieve and/or maintain in gas extraction assembly **206** and/or piping prior to that assembly any suitable temperatures. For example, heating assembly **214** may heat the gas extraction assembly to at least a target operating temperature and/or at least a minimum extraction or desorption temperature for the particular liquid absorbent used.

In some embodiments, heating assembly **214** may include a burner assembly **222** and may be configured to receive at least one fuel stream **218** and to combust the fuel stream in the presence of air to provide a hot combustion stream **216** that may be used to heat the gas removal reactor. Air may be delivered to the heating assembly via a variety of mechanisms. For example, an air stream **224** may be delivered to the heating assembly as a separate stream, as shown in FIG. **11**. Alternatively, or additionally, air stream **224** may be delivered to the heating assembly with at least one of the fuel streams **218** for heating assembly **214** and/or drawn from the environment within which the heating assembly is utilized.

Fuel stream **218** may include any combustible liquid(s) and/or gas(es) that are suitable for being consumed by heating assembly **214** to provide the desired heat output. Some fuel streams may be gases when delivered and combusted by heating assembly **214**, while others may be delivered to the heating assembly as a liquid stream. Examples of suitable heating fuels for fuel streams **218** include carbon-containing feedstocks, low molecular weight condensable fuels, and low molecular weight hydrocarbons. Other examples include hydrogen gas and/or carbon oxide gas from one or more byproduct streams **226**. For example, one or more byproduct streams **226** from other components and/or assemblies of the fuel processing system may be used as a suitable heating fuel for fuel stream **218**.

Combustion stream **216** may additionally, or alternatively, be used to heat other portions of the fuel processing system and/or other systems with which the heating assembly is used. Additionally, other configuration and types of heating assemblies **214** may be used. For example, heating assembly **214** may be an electrically powered heating assembly that is configured to heat gas extraction assembly **206** and/or piping upstream of that assembly by generating heat using at least one heating element (such as a resistive heating element), waste heat stream(s), solar heating, electric heating, etc. In those embodiments, heating assembly **214** may not receive and combust a combustible fuel stream to heat vaporizer to a suitable vaporization temperature and/or heat methane-producing reactor to a suitable methane-producing temperature.

The heating assembly also may be configured to heat other components and/or assemblies, such as a feedstock

19

delivery system, the feedstock supply streams, methane-producing assemblies, and/or other assemblies of the purification assembly, or any suitable combination of those systems, streams, and regions. The heating assembly may additionally be configured to heat other components of the refining assembly. For example, the heated exhaust stream may be configured to heat a pressure vessel and/or other canister containing the heating fuel and/or the hydrogen-production fluid that forms at least portions of the feed and/or fuel streams for the fuel processing system.

Heating assembly 214 may be housed in an assembly shell or housing 226 with the gas separation and gas extraction assemblies. The heating assembly may be separately positioned relative to one or both of those assemblies but in thermal and/or fluid communication with one or both to provide the desired heating. Heating assembly 214 may be located partially or completely within the common shell, and/or at least a portion (or all) of the heating assembly may be located external that shell. When the heating assembly is located external the shell, the hot combustion gases from burner assembly 222 may be delivered via suitable heat transfer conduits to one or more components within the shell.

Although gas removal assembly 184 (in FIG. 11), gas removal assembly 154 (FIG. 8), and methane-producing assembly 94 (in FIG. 2) are shown to each include a heating assembly, gas removal assembly 184, gas removal assembly 154, and/or methane-producing assembly 94 may have a common heating assembly that may be located within the shell of the methane-producing assembly, within the shell of one or more of the gas removal assemblies, or outside those shells. When there is a common heating assembly between the gas removal assemblies and the methane-producing assembly, the heating assembly may include suitable heat transfer conduits to transfer heat to the components of the gas removal and/or methane-producing assemblies. Additionally, when gas extraction assembly 206 includes two or more strippers 208, the gas extraction assembly may include a common heating assembly 214 for two or more of the strippers (and, in some embodiments, for all of the strippers). Moreover, although gas removal assembly 184 is shown to include a single gas separation assembly 186, a single gas extraction assembly 206, and a single heating assembly 214, the gas removal assembly may include two or more gas separation assemblies, two or more gas extraction assemblies, and/or two or more heating assemblies, as shown in dashed lines in FIG. 11.

Another example of refining assembly 30 is shown in FIG. 12, which is generally indicated at 230. Unless specifically excluded, refining assembly 230 may include one or more components of the other refining assemblies and/or other assemblies in this disclosure. Refining assembly 230 may include a feedstock delivery system 232 and a fuel processing system 234.

Feedstock delivery system 232 may include any suitable structure configured to deliver one or more feed and/or fuel streams to one or more other components of refining assembly 230. For example, the feedstock delivery system may include a water source 236, a rich natural gas source 238, and a pump 240. The water source may be a storage tank, a storage container, a water reservoir, a natural body of water, etc. configured to provide a water stream 242 (such as a deionized water stream) to fuel processing system 234. Rich natural gas source 238 may be a wellhead, a storage tank, a storage container, etc. configured to provide a rich natural gas stream 244 to fuel processing system. Pump 240 may have any suitable structure configured to deliver or transport

20

the water to fuel processing system 234. The rich natural gas stream 244 may combine with water stream 242 to form at least one liquid-containing feed stream 246. Alternatively, or additionally, the rich natural gas stream may be delivered or transported to fuel processing system 234 and combine with the water stream at the fuel processing system. In some embodiments, feedstock delivery system 232 may include one or more additional pumps and/or compressors to deliver or transport rich natural gas stream 244 to combine with water stream 242 and/or to fuel processing system 234.

Fuel processing system 234 may include any suitable structure configured to process rich natural gas stream(s) 244, such as to increase concentration of methane gas and/or reduce concentration of other components in the rich natural gas stream. For example, fuel processing system 234 may include at least one methane-producing assembly 248, a heat exchange assembly 250, a water removal assembly 252, a first gas removal assembly 254, and a second gas removal assembly 258.

Methane-producing assembly 248 may include any suitable structure configured to receive liquid-containing feed stream(s) 246 (or water stream(s) 242 and rich natural gas stream(s) 244) and produce an output stream 260 containing methane gas as the primary component but also containing water and other gases. For example, methane-producing assembly 248 may include at least one vaporization region or vaporizer 262, at least one methane-producing region or reactor 264, and at least one heating assembly 266, as shown in FIG. 13.

Vaporizer 262 may include any suitable structure configured to receive and vaporize at least a portion of a liquid-containing feed stream, such as liquid-containing feed stream 246. For example, vaporizer 262 may be configured to at least partially transform liquid-containing feed stream 246 into one or more at least substantially vaporized streams 268. The at least substantially vaporized streams may, in some embodiments, include liquid(s). An example of a suitable vaporizer is a coiled tube vaporizer, such as a coiled stainless steel tube.

Methane-producing reactor 264 may include any suitable structure configured to receive one or more feed streams, such as at least substantially vaporized stream(s) 268 from the vaporizer, to produce one or more output streams 260 containing methane gas as a majority component, water, and other gases. The methane-producing reactor may produce the output stream via any suitable mechanism(s). For example, methane-producing reactor 264 may generate output stream(s) 260 via a heavy hydrocarbon reforming reaction. In that example, methane-producing reactor 264 may include a catalyst 270 configured to facilitate and/or promote the heavy hydrocarbon reforming reaction. When methane-producing reactor 264 generates output stream(s) 260 via a heavy hydrocarbon reforming reaction, methane-producing reactor may be referred to as a "heavy hydrocarbon reforming reactor" or "HHR reactor," and output stream 260 may be referred to as a "reformate stream."

Heating assembly 266 may include any suitable structure configured to produce at least one heated exhaust stream 272 for heating one or more other components of the methane-producing assembly. For example, the heating assembly may heat the vaporizer to any suitable temperature(s), such as at least a minimum vaporization temperature or the temperature in which at least a portion of the liquid-containing feed stream is vaporized to form the at least substantially vaporized stream. Additionally, or alternatively, heating assembly 266 may heat the methane-producing reactor to any suitable temperature(s), such as at least a minimum methane-pro-

ducing temperature or the temperature in which at least a portion of the vaporized feed stream is reacted to produce methane gas to form the output stream. The heating assembly may be in thermal communication with one or more other components of the methane-producing assembly, such as the vaporizer and/or methane-producing reactor.

The heating assembly may include a burner assembly 274, at least one air blower 276, and an igniter assembly 278, as shown in FIG. 13. The burner assembly may include any suitable structure configured to receive at least one air stream 280 and at least one fuel stream 282 and to combust the at least one fuel stream to produce heated exhaust stream(s) 272. The fuel stream may be provided by feedstock delivery system 232 and/or one or more of the gas removal assemblies. For example, one or more gas removal assemblies that remove carbon oxide gas and/or hydrogen gas may send those gases to burner assembly 274 as a byproduct fuel stream 283.

Fuel streams 282 and/or 283 may be delivered to burner assembly 274 via a pump 284 and/or other suitable device. If fuel streams 282 and/or 283 are available at sufficient pressure, pump 284 may not be necessary and may be excluded. Although pump 284 is shown to transport fuel stream 282 and not byproduct fuel stream 283 to burner assembly 274, the pump may alternatively, or additionally, transport byproduct fuel stream 283 to burner assembly 274, or one or more other pumps may transport the byproduct fuel stream to the burner assembly. Diaphragm and piston pumping mechanisms are examples of suitable pumps for use as pump 284, although other types of pumps and compressors may be used. Air blower 276 may include any suitable structure configured to generate air stream(s) 280. Igniter assembly 278 may include any suitable structure configured to ignite fuel stream(s) 282 and/or 283. Although methane-producing assembly 248 is shown to include a single vaporizer 262, a single methane-producing reactor 264, and a single heating assembly 266, the methane-producing assembly may include two or more vaporizers 262, two or more methane-producing reactors 264, and/or two or more heating assemblies 266, as shown in dashed lines in FIG. 13.

In some embodiments, methane-producing assembly 248 may include a shell or housing 285 which may at least partially contain one or more other components of that assembly. For example, shell 285 may at least partially contain vaporizer 262, methane-producing reactor 264, and/or heating assembly 266, as shown in FIG. 13. Shell 285 may include one or more exhaust ports 286 configured to discharge at least one combustion exhaust stream 287 produced by heating assembly 266. The shell or housing may include insulation and/or a jacket.

Referring back to FIG. 12, heat exchange assembly 250 may include one or more heat exchangers configured to transfer heat from one portion of the refining assembly to one or more other portion(s). For example, heat exchange assembly 250 may include a first heat exchanger 288 and a second heat exchanger 289. The first heat exchanger may be configured to transfer heat from output stream 260 to an at least substantially dried stream 290 exiting water removal assembly 252 to raise the temperature of the substantially dried stream prior to gas removal assembly 254, as well as to cool output stream 260 prior to water removal assembly 252. Second heat exchanger 289 may be configured to cool an intermediate stream 292 exiting an upstream gas removal assembly (such as first gas removal assembly 254) prior to another gas removal assembly (such as second gas removal assembly 258). For example, second heat exchanger 289 may cool intermediate stream 292 to less than or equal to

100° C., and preferably less than or equal to 50° C. In some embodiments, heat exchange assembly 250 may include one or more fans 294 to cool one or more streams passing through the first and/or second heat exchangers. Although second heat exchanger 289 is shown to receive only the cooling stream(s) from fan(s) 294, that heat exchanger may alternatively, or additionally, receive one or more other cooling fluid streams (such as from one or more other portions or components of the refining assembly)

Water removal assembly 252 may include any suitable structure configured to remove water from output stream 260 to produce at least substantially dried stream 290. For example, water removal assembly 252 may include at least one gas dryer 296 configured to remove at least a substantial portion of water vapor from output stream 260 and to form at least one reclaimed water stream 298 from the removed water vapor. In some embodiments, the water removal assembly may include at least one water knockout device 299 configured to remove at least a substantial portion of liquid water from output stream 260. When refining assembly 230 includes one or more water knockout device(s) 299, those devices may be immediately upstream of (or immediately prior to) the gas dryer(s) and may produce at least a portion of reclaimed water stream 298 from the removed water. In some embodiments, water removal assembly 252 may include a reclaimed water pump 300 configured to move or transport the reclaimed water stream to feedstock delivery system 232, such as to add or supplement water to water source 236. The reclaimed water stream(s) also may be sent to one or more other components of refining assembly 230, sent to drain, and/or otherwise disposed.

First gas removal assembly 254 may include any suitable structure configured to remove one or more other gases (such as gas(es) other than methane gas) from one or more streams, such as at least substantially dried stream(s) 290, and to produce one or more intermediate streams 292 having a lower concentration of the other gases and/or a higher concentration of methane gas. In some embodiments, intermediate stream(s) 292 may include less than 5% hydrogen gas, and preferably less than 3% hydrogen gas. For example, first gas removal assembly 254 may include at least one gas removal region or reactor 302 and at least one heating assembly 304, as shown in FIG. 14.

Gas removal reactor 302 may include any suitable structure configured to receive one or more at least substantially dried streams 290, and to produce one or more intermediate streams 292. The gas removal reactor may produce the intermediate stream via any suitable mechanism(s). For example, gas removal reactor 302 may generate intermediate stream(s) 292 via a methanation reaction. In that example, gas removal reactor 302 may include a catalyst 306 configured to facilitate and/or promote the methanation reaction. When gas removal reactor 302 generates intermediate stream(s) 292 via a methanation reaction, the gas removal reactor may be referred to as a "synthetic natural gas reactor" or "SNG reactor."

Heating assembly 304 may include any suitable structure configured to produce at least one heated exhaust stream 308 for heating one or more other components of the gas removal assembly. For example, the heating assembly may heat the gas removal reactor to any suitable temperature(s), such as at least a minimum methanation or the temperature in which at least a portion of the carbon oxide gas and hydrogen gas in the at least substantially dried stream is reacted to produce methane gas and water to form the intermediate stream. The heating assembly may be in thermal communication with

23

one or more other components of the gas removal assembly, such as the gas removal reactor.

The heating assembly may include a burner assembly 310, at least one air blower 312, and an igniter assembly 314, as shown in FIG. 14. The burner assembly may include any suitable structure configured to receive at least one air stream 316 and at least one fuel stream 318 and to combust the at least one fuel stream to produce heated exhaust stream(s) 308. The fuel stream may be provided by feedstock delivery system 232 and/or one or more other gas removal assemblies. For example, one or more gas removal assemblies that remove carbon oxide gas and/or hydrogen gas may send those gases to burner assembly 310 as a byproduct fuel stream 320.

Fuel streams 318 and/or 320 may be delivered to burner assembly 310 via one or more pumps 324 and/or other suitable device. If fuel streams 318 and/or 320 are available at sufficient pressure, pump 324 may not be necessary and may be excluded. Although pump 324 is shown to transport fuel stream 318 and not byproduct stream 320 to burner assembly 310, the pump may alternatively, or additionally, transport byproduct fuel stream 320 to burner assembly 310, or one or more other pumps may transport the byproduct fuel stream to the burner assembly. Diaphragm and piston pumping mechanisms are examples of suitable pumps for use as pump 324, although other types of pumps and compressors may be used. Air blower 312 may include any suitable structure configured to generate air stream(s) 316. Igniter assembly 314 may include any suitable structure configured to ignite stream(s) 318 and/or 320. Although gas removal assembly 254 is shown to include a single gas removal reactor 302 and a single heating assembly 304, the gas removal assembly may include two or more gas removal reactors 302 and/or two or more heating assemblies 304, as shown in dashed lines in FIG. 14.

In some embodiments, gas removal assembly 254 may include a shell or housing 326 which may at least partially contain one or more other components of that assembly. For example, shell 326 may at least partially contain gas removal reactor 302 and/or heating assembly 304, as shown in FIG. 14. Shell 326 may include one or more exhaust ports 328 configured to discharge at least one combustion exhaust stream 330 produced by heating assembly 304. Shell or housing 326 may include insulation and/or a jacket.

Referring back to FIG. 12, refining assembly 230 may, in some embodiments, include one or more additional heat exchangers 334, one or more additional water removal assemblies 336 (having one or more pumps 337 for transporting reclaimed water to the feedstock delivery system), and one or more additional gas removal assemblies 338. Water removal assemblies 336 and/or gas removal assemblies 338 may be the same or different from water removal assembly 252 and first gas removal assembly 254, respectively. For example, water removal assembly 336 may include a gas dryer. Additionally, gas removal assembly 338 may include a gas removal reactor, such as a SNG reactor. Alternatively, gas removal assembly 338 may include one or more components of second gas removal assembly 258 described below. Although only a single heat exchanger 334, a single water removal assembly 336, and a single gas removal assembly 338 is shown in FIG. 12, refining assembly 230 may include additional heat exchangers, water removal assemblies, and gas removal assemblies, which may be in series and/or in parallel with heat exchanger 334, water removal assembly 336, and gas removal assembly 338. The additional water removal assemblies and gas

24

removal assemblies may be the same or different from water removal assembly 336 and gas removal assembly 338, respectively.

Second gas removal assembly 258 may include any suitable structure configured to remove one or more other gases (such as gas(es) other than methane gas) from one or more streams, such as intermediate stream(s) 292 to form at least one methane-rich stream 332, which may include a greater methane concentration than intermediate stream(s) 292 and/or a reduced concentration of one or more other gases (or impurities) that were present in the intermediate stream(s). In some embodiments, the second gas removal assembly may form at least one byproduct stream 333 with the removed gases. Examples of second gas removal assemblies 258 are described below.

Refining assembly 230 may, in some embodiments, include a control system 340, which may include any suitable structure configured to control and/or monitor operation of the refining assembly. For example, control system 340 may include a control assembly 342, one or more flow measurement devices 344, one or more temperature measurement devices 346, and one or more control valves 348, as shown in FIGS. 12-13.

Control assembly 342 may detect flow rate of rich natural gas stream 244 and adjust delivery (such as the flow rate) of water stream 242 based, at least in part, on the detected flow rate. Additionally, control assembly 342 may detect temperatures in the methane-producing reactor and/or gas removal reactor via temperature measurement devices 346 (such as thermocouples and/or other suitable devices) and adjust flow rate of the fuel stream(s) and/or byproduct fuel stream(s) via control valves 348 and/or adjust flow rate of the air stream(s) by controlling speed of the air blower(s), based, at least in part, on the detected temperature(s). For example, control assembly 342 may increase flow rate of the fuel stream(s) and/or byproduct fuel stream(s) via control valve(s) 348, if the detected temperature is lower than a minimum temperature (such as a minimum methane-producing temperature or a minimum gas removal temperature). Additionally, control assembly 342 may decrease flow rate of the fuel stream(s) and/or byproduct fuel stream(s) via control valve(s) 348 and/or increase the speed of the air blower(s), if the detected temperature is higher than a maximum temperature (such as a maximum methane-producing temperature or a maximum gas removal temperature).

In some embodiments, control system 340 may include one or more other measurement devices, such as to measure sulfur breakthrough in the rich natural gas stream, conductivity (or resistivity) of the deionized water in the water stream, pump motor speed(s), pump discharge flow rate(s), operating temperature(s), operating pressure(s), etc. Control assembly 342 may provide early warning of a impending need for maintenance based, at least in part, on one or more measurement devices. In some embodiments, control system 340 may provide for remote monitoring and control of one or more components of refining assembly 230.

An example of second gas removal assembly 258 is shown in FIG. 15, which is generally indicated at 350. Unless specifically excluded, second gas removal assembly 258 may include one or more components of the other gas removal assemblies and/or other assemblies in this disclosure. Gas removal assembly 350 may include at least one absorber 352, at least one stripper 354, at least one heating assembly 356, at least one pump 358, and at least one heat exchanger 360.

25

Absorber **352** may include any suitable structure configured to receive a liquid absorbent stream **362** that is adapted to absorb at least a portion of carbon oxide gas and/or hydrogen gas from one or more streams, such as intermediate stream(s) **292**, and/or to direct flow of those streams (such as intermediate stream **292**) through the liquid absorbent stream. For example, absorber **352** may include at least one spray nozzle **364** configured to at least partially atomize the liquid absorbent stream into one or more sprayed liquid absorbent streams **366**. The absorber may be configured to direct flow of intermediate stream(s) **292** through sprayed liquid absorbent stream(s) **366** in any suitable flow configuration, such as counter-current flow, cross-current flow, or parallel flow. As intermediate stream(s) **292** flows through the sprayed liquid absorbent stream(s), carbon oxide gas and/or hydrogen gas may, at least partially, be absorbed by the sprayed stream(s) to form methane-rich stream **332** without the absorbed carbon oxide gas and/or hydrogen gas and a spent liquid absorbent stream **368** having the absorbed carbon oxide gas and/or hydrogen gas. Absorber **352** may be operated at a pressure of less than 100 psig, and preferably at a pressure between 10 psig and 50 psig.

Although FIG. **15** shows absorber **352** with spray nozzle(s) **364**, another suitable configuration is to return liquid absorbent stream **362** without using a spray nozzle. For example, liquid absorbent stream **362** may enter a top, middle, or bottom portion of absorber **352** through a suitable tube or pipe connection, and the liquid absorbent may be allowed to accumulate a fill a volume at the bottom of the absorber. Intermediate stream **292** may be directed to bubble up through the volume of the liquid absorbent to remove at least a portion of carbon oxide gas and/or hydrogen gas to form methane-rich stream **332**.

Stripper **354** may include any suitable structure configured to receive one or more spent liquid absorbent streams **368**, strip the absorbed carbon oxide gas and/or hydrogen gas from those stream(s), and/or deliver one or more stripped liquid absorbent streams **370** to absorber(s) **352**. For example, stripper **354** may include at least one spray nozzle **372** configured to at least partially atomize the spent liquid absorbent stream into one or more sprayed spent liquid absorbent streams **374**. Stripper **354** may strip the absorbed carbon oxide gas and/or hydrogen gas via any suitable mechanism(s). For example, when the liquid absorbent(s) used for liquid absorbent stream **362** absorbs or binds carbon oxide gas and/or hydrogen gas within a first temperature range and releases or desorbs carbon oxide gas and/or hydrogen gas within a second temperature range higher than the first temperature range, then stripper **354** may be configured to receive one or more heated exhaust streams **376** from heating assembly **356** and direct the flow of those streams through the sprayed spent liquid absorbent stream(s).

For example, the sprayed spent liquid stream(s) may be heated by the heated exhaust stream(s) between 60° C. and 200° C., and preferably between 80° C. and 150° C., to drive off the absorbed carbon oxide gas and/or hydrogen gas to produce or yield at least substantially regenerated liquid absorbent stream **370**. The released of desorbed gasses may form at least one offgas stream **377**. Stripper **354** may be operated within the range of 0 psig and 50 psig, and preferably 0 psig and 10 psig.

Heating assembly **356** may include any suitable structure configured to produce at least one heated exhaust stream **376** for heating sprayed spent liquid absorbent stream(s) **374**. For example, the heating assembly may heat the stripper to any suitable temperature(s), such as at least a minimum

26

release or desorption temperature for the carbon oxide gas and/or hydrogen gas in the sprayed spent liquid absorbent stream(s).

The heating assembly may include a burner assembly **378**, at least one air blower **380**, and an igniter assembly **382**, as shown in FIG. **15**. The burner assembly may include any suitable structure configured to receive at least one air stream **384** and at least one fuel stream **386** and to combust the at least one fuel stream to produce heated exhaust stream(s) **376**. The fuel stream may be provided by feedstock delivery system **232** and/or one or more of the gas removal assemblies. For example, one or more gas removal assemblies that remove carbon oxide gas and/or hydrogen gas may send those gases to burner assembly **378** as a byproduct fuel stream **388**. Additionally, at least a portion of offgas stream **377** may be used as that byproduct fuel stream. Fuel streams **386** and/or **388** may be delivered to burner assembly **378** via a pump and/or other suitable device. Air blower **380** may include any suitable structure configured to generate air stream(s) **384**. Igniter assembly **382** may include any suitable structure configured to ignite fuel stream(s) **386** and/or **388**.

Additionally, other configuration and types of heating assemblies **356** may be used. For example, heating assembly **356** may include at least one heater **394** that is powered by at least one power assembly **396**, as shown in FIG. **16**. Heater **394** may include at least one heating element **398** (such as a resistive heating element). The heating element may heat spent liquid absorbent stream **368** prior to stripper **354** (and/or spray nozzle **372**) and/or may heat the spent liquid absorbent stream in the stripper. Power assembly **396** may include one or more electric cords (to allow a user to plug the heater into an electrical outlet), solar panels, wind turbines, fuel cells, etc.

Pump **358** may include suitable structure configured to deliver or transport stripped liquid absorbent stream(s) **370** to absorber **352** (such as through spray nozzle **364** or a suitable tube or pipe connection) for absorption of at least a portion of carbon oxide gas and/or hydrogen gas from intermediate stream(s) **292**. Heat exchanger **360** may include any suitable structure configured to transfer heat from the stripped liquid absorbent stream(s) to the spent liquid absorbent stream(s).

In some embodiments, control system **340** may further include one or more fluid level measurement devices **390**, as shown in FIG. **15**. Control assembly **342** may detect fluid level in absorber **352** and/or stripper **354** via fluid level measurement devices **390**, and control the speed of pump **358** based, at least in part, on the detected fluid level(s). For example, control assembly **342** may reduce the speed of pump **358** (or the flow rate of stripped liquid absorbent stream **370**) when fluid level in absorber **342** is above a predetermined maximum level or the fluid level in stripper **354** is below a predetermined minimum level. Additionally, control assembly **342** may increase the speed of pump **358** when fluid level in absorber **342** is below a predetermined minimum level or the fluid level in stripper **354** is above a predetermined maximum level. Moreover, control assembly **342** may detect the temperature of spent liquid absorbent stream **368** after that stream is heated by heater **394** (e.g., prior to stripper **354** or in stripper **354**) in FIG. **16** via temperature measurement devices **346**, and control the temperature setting and/or power to the heater based, at least in part, on the detected temperature. For example, control assembly **342** may increase heat provided by the heater if the detected temperature is below a minimum release temperature for the absorbed carbon oxide gas and/or hydrogen gas.

27

In some embodiments, gas removal assembly **350** may include a shell or housing **392** which may at least partially contain one or more other components of that assembly. For example, shell **392** may at least partially contain absorber **352**, stripper **354**, heating assembly **356**, pump **358**, and/or heat exchanger **360**, as shown in FIGS. 15-16. The shell or housing may include insulation and/or a jacket.

Another example of second gas removal assembly **258** is shown in FIG. 17, which is generally indicated at **400**. Unless specifically excluded, second gas removal assembly **400** may include one or more components of the other gas removal assemblies in this disclosure. Second gas removal assembly **400** may include one or more absorbers **402** and control valves **404**.

Absorbers **402** may include at least one solid absorbent **406** (such as in solid absorbent beds) adapted to absorb at least a portion of carbon oxide gas and/or hydrogen gas from one or more streams, such as intermediate stream(s) **292**, and/or to direct flow of those streams through the solid absorbent. As intermediate stream(s) **292** flow through the solid absorbent, carbon oxide gas and/or hydrogen gas may, at least partially, be absorbed forming methane-rich stream **332** without the absorbed carbon oxide gas and/or hydrogen gas. Second gas removal assembly **400** may include any suitable number of absorbers **402**. For example, the second gas removal assembly may include a first absorber **408** and a second absorber **410**, as shown in FIG. 17. Although second gas removal assembly **400** is shown to include two absorbers **402**, the assembly may include any suitable number of absorbers, such as one absorber or three or more absorbers.

When second gas removal assembly **400** includes two or more absorbers **402**, the second gas removal assembly may include two or more control valves **404**, which may include any suitable structure configured to isolate one or more absorbers **402** and/or direct flow to one or more other absorbers **402**. For example, intermediate stream **292** may be directed to flow through first absorber **408** until the solid absorbent in that absorber is saturated or substantially saturated with carbon oxide gas and/or hydrogen gas. At that point, control valves **404** may isolate first absorber **408** and direct flow of intermediate stream **292** through second absorber **410** until the solid absorbent in the second absorber is saturated or substantially saturated. The solid absorbent in the isolated first absorber may be recharged or regenerated while intermediate stream **292** is flowing through the second absorber, or vice-versa. In some embodiments, control valves **404** may be three-way valves directing flow of intermediate stream **292** to either the first or second absorbers and/or directing flow of methane-rich stream **332** from either the first or second absorbers.

In some embodiments, control system **340** may include one or more saturation measurement devices **412**. In those embodiments, control assembly **342** may control operation of control valves **404** based, at least in part, on the detected saturation. For example, control assembly **342** may control the control valves to direct flow from a first absorber to a second absorber when the first absorber is above a predetermined maximum saturation level. In some embodiments, gas removal assembly **400** may include a shell or housing **413** which may at least partially contain one or more other components of that assembly. For example, shell **413** may at least partially contain absorbers **402** and control valves **404**, as shown in FIG. 17. The shell or housing may include insulation and/or a jacket.

Another example of second gas removal assembly **258** is shown in FIG. 18, which is generally indicated at **414**.

28

Unless specifically excluded, second gas removal assembly **414** may include one or more components of the other gas removal assemblies and/or other assemblies in this disclosure. Second gas removal assembly **414** may include a water removal assembly **416** and a membrane assembly **418**.

Water removal assembly **416** may include any suitable structure configured to remove water vapor and/or liquid water from one or more streams, such as intermediate stream **292**, to form an at least substantially dried stream **420**. For example, water removal assembly **416** may include at least one water knockout device **422** and/or at least one gas dryer **424**. Water removed by water removal assembly **416** may form at least one reclaimed water stream **426** that may be sent to feedstock delivery system **232** and/or other components of refining assembly **230**.

Membrane assembly **418** may include any suitable structure configured to separate at least a portion of carbon oxide gas and/or hydrogen gas from at least substantially dried stream **420** to form methane-rich stream **332**. The separated carbon oxide gas and/or hydrogen gas may form byproduct stream **333**, which may be sent to feedstock delivery system **232**, one or more heating assemblies of other gas removal assemblies, and/or other components of refining assembly **230**. For example, membrane assembly **418** may include one or more carbon oxide selective membranes **428** that are configured to separate at least a portion of carbon oxide gas and/or hydrogen gas from stream(s) **420**. Membrane assembly **418** may include any suitable number of membranes **428**, as shown in dashed lines in FIG. 18. When membrane assembly **418** includes two or more membranes **428**, those membranes may be arranged in parallel or in series. In some embodiments, gas removal assembly **414** may include a shell or housing **429** which may at least partially contain one or more other components of that assembly. For example, shell **429** may at least partially contain membrane assembly **418**, as shown in FIG. 18. The shell or housing may include insulation and/or a jacket.

Another example of second gas removal assembly **258** is shown in FIG. 19, which is generally indicated at **430**. Unless specifically excluded, second gas removal assembly **430** may include one or more components of the other gas removal assemblies and/or other assemblies in this disclosure. Second gas removal assembly **430** may include a water removal assembly **432**, a membrane contactor assembly **434**, at least one stripper **436**, at least one heating assembly **438**, at least one heat exchanger **440**, and at least one pump **442**.

Water removal assembly **432** may include any suitable structure configured to remove water vapor and/or liquid water from one or more streams, such as intermediate stream **292**, to form at least substantially dried stream **444**. For example, water removal assembly **432** may include at least one water knockout device **446** and/or at least one gas dryer **448**. Water removed by water removal assembly **432** may form at least one reclaimed water stream **450** that may be sent to feedstock delivery system **232** and/or other components of refining assembly **230**.

Membrane contactor assembly **434** may include any suitable structure configured to separate carbon oxide gas and/or hydrogen gas from at least substantially dried stream **444** to form methane-rich stream **332**. For example, membrane contactor assembly **434** may include one or more membrane contactors **452**. Membrane contactor may include a plurality of carbon oxide selective membranes **454** that are configured to separate at least a portion of carbon oxide gas and/or hydrogen gas from stream(s) **444**.

Membranes **454** may be hollow fiber or small-diameter tubular membranes, which may be sealed (or potted) into a

shell **456**, as shown in FIG. **20**. Shell **456** may include inlet and outlet ports **457** and any suitable number of membranes **454**, such as hundreds to thousands of those membranes. Membranes **454** may have any suitable lengths, such as from about one centimeter to about two to three meters, and/or

any suitable diameters, such as from 0.1 millimeters to 5 millimeters. The membranes may be configured to be microporous and/or highly permeable to carbon oxide gas and/or hydrogen gas.

Membranes **454** may be composed of material(s) that are chemically inert to the components of at least substantially dried stream(s) **444** (and/or output stream **292**), whether those components are in gas phase and/or liquid phase. Additionally, when membranes **454** are microporous, the membranes may be composed of one or more materials that are not wet by the liquid phase of the components of streams **444** and/or **292**, and/or liquid absorbent stream **470**. In other words, the liquid phase of those components is not drawn into the micropore structure by capillary forces. Otherwise, if the micropore structure of the membranes is filled with the liquid phase, then relatively slow diffusion of carbon oxide gas out of the liquid-filled pores may adversely affect overall performance of the membranes. An example of a suitable microporous polypropylene membrane is made by Celgard®, LLC (Charlotte, N.C.).

Membrane contactor(s) **452** may direct flow of at least substantially dried stream **444** (or intermediate stream **292**, if that stream is not sent to water removal assembly **432**) through a bore or lumen **458** of membranes **454**, as shown in FIG. **21**. At least a portion of carbon oxide gas and/or hydrogen gas may pass through one or more walls **460** into the membrane contactor shell, as indicated at **462** in FIG. **21**. When streams **444** or **292** are directed to flow into and/or through lumen **458** of membranes **454**, the interior of the lumens may be referred to as “feed side **466**” and the interior of the shell (and/or exterior of the membranes) may be referred to as “permeate side **468**.”

Alternatively, the membrane contactor(s) may direct flow of at least substantially dried stream **444** (or intermediate stream **292**) through the membrane contactor shell and/or over the membranes, as shown in FIG. **22**. At least a portion of carbon oxide gas and/or hydrogen gas may pass through wall(s) **460** into lumen **458** of membranes **454**, as indicated at **464** in FIG. **22**. When streams **444** or **292** are directed to flow into and/or through the membrane contactor shell and/or over the membranes, the interior of the membrane contactor shell or exterior of the membranes may be referred to as “feed side **466**” and the interior of the lumens may be referred to as “permeate side **468**.” Preferably, streams **444** or **292** are directed to flow through the lumens of the membranes when the lumen diameter is small and the length of the membrane is long to prevent high pressure drops that would be encountered if liquid absorbent stream **470** is directed to flow through the lumens.

Additionally, membrane contactor(s) **452** may receive at least one liquid absorbent stream **470** at the permeate side of the membranes. The liquid absorbent stream may be adapted to absorb at least a portion of carbon oxide gas and/or hydrogen gas that passes from the feed side to the permeate side of membranes **454** to form liquid absorbent stream(s) **472** having absorbed carbon oxide gas and/or hydrogen gas (which also may be referred to as “spent liquid absorbent stream(s) **472**”). For example, when membrane contactor(s) **452** are configured to receive at least substantially dried stream **444** (or intermediate stream **292**) through lumens **458** of membranes **454**, the membrane contactors may receive liquid absorbent stream **470** in membrane contactor shell

Alternatively, when membrane contactor(s) **452** are configured to receive streams **444** or **292** through membrane contactor shell **456**, the membrane contactors may receive the liquid absorbent stream through lumens **458** of membranes **454**. The liquid absorbent(s) in liquid absorbent stream(s) **470** may be configured to absorb (or bind) at least a portion of carbon oxide gas and/or hydrogen gas at relatively low temperatures and then release (or desorb) those gas(es) at elevated temperatures. Preferably, the liquid absorbent(s) in liquid absorbent stream(s) **470** are not driven by a pressure cycle.

Membrane contactor assembly **434** may include any suitable number of membrane contactors **452**, as shown in dashed lines in FIG. **19**. When membrane contactor assembly **434** includes two or more membrane contactors **452**, those membrane contactors may be arranged in parallel or in series. Stripper **436** may include any suitable structure configured to receive one or more spent liquid absorbent streams **472**, strip the absorbed carbon oxide gas and/or hydrogen gas from those stream(s), and/or deliver one or more stripped liquid absorbent streams **474** to membrane contactor(s) **452**. For example, stripper **436** may include at least one spray nozzle **476** configured to at least partially atomize the spent liquid absorbent stream into one or more sprayed spent liquid absorbent streams **478**. Stripper **436** may strip the absorbed carbon oxide gas and/or hydrogen gas via any suitable mechanism(s). For example, when the liquid absorbent(s) used for liquid absorbent stream **470** absorbs or binds carbon oxide gas and/or hydrogen gas within a first temperature range and releases or desorbs carbon oxide gas and/or hydrogen gas within a second temperature range higher than the first temperature range, then stripper **436** may be configured to receive one or more heated exhaust streams **480** from heating assembly **438** and direct the flow of those streams through the sprayed spent liquid absorbent stream(s).

The sprayed spent liquid stream(s) may be heated by the heated exhaust stream(s) between 60° C. and 200° C., and preferably between 80° C. and 150° C., to drive off the absorbed carbon oxide gas and/or hydrogen gas to produce or yield at least substantially regenerated liquid absorbent stream **474**. The released or desorbed gasses may form at least one offgas stream **482**. Stripper **436** may be operated within the range of 0 psig and 50 psig, and most preferably in the range of 0 psig and 10 psig.

Heating assembly **438** may include any suitable structure configured to produce at least one heated exhaust stream **480** for heating sprayed spent liquid absorbent stream(s) **478**. For example, the heating assembly may heat the stripper to any suitable temperature(s), such as at least a minimum release or desorption temperature for the carbon oxide gas and/or hydrogen gas in the sprayed spent liquid absorbent stream(s).

The heating assembly may include a burner assembly **484**, at least one air blower **486**, and an igniter assembly **488**, as shown in FIG. **19**. The burner assembly may include any suitable structure configured to receive at least one air stream **490** and at least one fuel stream **492** and to combust the at least one fuel stream to produce heated exhaust stream(s) **480**. The fuel stream(s) may be provided by feedstock delivery system **232** and/or one or more of the gas removal assemblies. For example, one or more gas removal assemblies that remove carbon oxide gas and/or hydrogen gas may send those gases to burner assembly **484** as a byproduct fuel stream **494**. In some embodiments, at least a portion of offgas stream **482** may supplement fuel streams **492** and/or **494**. Fuel streams **492**, **494**, and/or **482** may be

delivered to burner assembly 378 via pump(s) and/or other suitable device(s). Air blower 486 may include any suitable structure configured to generate air stream(s) 492. Igniter assembly 488 may include any suitable structure configured to ignite fuel stream(s) 492, 494, and/or 482.

Additionally, other configuration and types of heating assemblies 438 may be used. For example, heating assembly 438 may include at least one heater 498 that is powered by at least one power assembly 500, as shown in FIG. 23. Heater 498 may include at least one heating element 502 (such as a resistive heating element). The heating element may heat spent liquid absorbent stream 472 prior to stripper 436 (and/or spray nozzle 476) and/or may heat the spent liquid absorbent stream in the stripper. Power assembly 500 may include one or more electric cords (to allow a user to plug the heater into an electrical outlet), solar panels, wind turbines, fuel cells, etc.

Heat exchanger 440 may include any suitable structure configured to transfer heat from the stripped liquid absorbent stream(s) to the spent liquid absorbent stream(s). Pump 442 may include suitable structure configured to deliver or transport stripped liquid absorbent stream(s) 474 to membrane contactor(s) 452 for additional absorption of carbon oxide gas and/or hydrogen gas from at least substantially dried stream 444 (or intermediate stream 292).

In some embodiments, control system 340 may further include pressure measurement devices 504 and at least one control valve 506, as shown in FIG. 19. Pressure measurement devices 504 may include pressure transducers or a differential pressure transducer that provides a feedback signal (typically 4-20 mA or voltage, such as 0-5 volts, 0-10 volts, or 0.5 to 4.5 volts) that is registered and processed by control assembly 342. Control valve 506 may include, for example, a proportional valve. Control assembly 342 may detect pressure in at least substantially dried stream 444 and spent liquid absorbent stream 472 via pressure measurement devices 504, and control the control valve based, at least in part, on the detected pressures. For example, control assembly 342 may be configured to ensure that the pressure of the spent liquid absorbent stream is higher than the pressure in the at least substantially dried stream to prevent the at least substantially dried stream from flowing from the feed side to the permeate side and bubble through the liquid absorbent stream.

Control assembly 342 may interpret the pressure measurements from the pressure measurement devices and signal control valve 506 to proportionally open if the pressure of the spent liquid absorbent stream is above the pressure of the at least substantially dried stream by more than a predetermined pressure (or pressure range), and to proportionally close if the pressure of the spent liquid absorbent stream is below the pressure of the at least substantially dried stream by less than a predetermined pressure (or pressure range). An example of a predetermined pressure range is 5 psig to 15 psig higher than the pressure of the at least substantially dried stream. However, other pressure ranges (and/or pressures) may be selected.

In some embodiments, gas removal assembly 430 may include a shell or housing 508 which may at least partially contain one or more other components of that assembly. For example, shell 508 may at least partially contain membrane contactor assembly 434, stripper 436, heating assembly 438, heat exchanger 440, and/or pump 442, as shown in FIGS. 19 and 23. In some embodiments, shell 508 may include insulation and/or a jacket.

Another example of refining assembly 30 is shown in FIG. 24, which is generally indicated at 510. Unless spe-

cifically excluded, refining assembly 510 may include one or more components of the other refining assemblies and/or other assemblies in this disclosure. Refining assembly 510 may include a feedstock delivery system 512 and a fuel processing system 514.

Feedstock delivery system 512 may include any suitable structure configured to deliver one or more feed and/or fuel streams to one or more other components of refining assembly 510. For example, the feedstock delivery system may include a water source 516, a rich natural gas source 518, and a pump 520. The water source may be a storage tank, a storage container, a water reservoir, a natural body of water, etc. configured to provide a water stream 522 (such as a deionized water stream) to fuel processing system 514. Rich natural gas source 518 may be a wellhead, a storage tank, a storage container, etc. configured to provide a rich natural gas stream 524 to fuel processing system 514. Pump 520 may have any suitable structure configured to deliver or transport the water to fuel processing system 514. The rich natural gas stream may combine with the water stream to form at least one liquid-containing feed stream 526. Alternatively, or additionally, the rich natural gas stream may be delivered or transported to fuel processing system 514 and combine with the water stream at the fuel processing system. In some embodiments, feedstock delivery system 512 may include one or more additional pumps and/or compressors to deliver or transport rich natural gas stream 524 and/or water stream 522 and/or to fuel processing system 514.

Fuel processing system 514 may include any suitable structure configured to process rich natural gas stream(s) 524, such as to increase concentration of methane gas and/or reduce concentration of other components in the rich natural gas stream. For example, fuel processing system 514 may include at least one methane-producing assembly 528, a heat exchange assembly 530, a water removal assembly 532, and a membrane assembly 534.

Methane-producing assembly 528 may include any suitable structure configured to receive liquid-containing feed stream(s) 526 and produce an output stream 536 containing methane gas as the primary component but also containing water and other gases. For example, methane-producing assembly 528 may include at least one heavy hydrocarbon reforming (HHR) reactor 538 having a HHR catalyst 540.

Heat exchange assembly 530 may include one or more heat exchangers configured to transfer heat from one portion of the refining assembly to another portion. For example, heat exchange assembly 532 may include at least one heat exchanger 538 and one or more fans 540 configured to cool output stream 536. Although heat exchanger 538 is shown to cool output stream 536 via fan(s) 540, the heat exchanger may alternatively, or additionally, be cooled via one or more cooling fluid streams (such as one or more water streams).

Water removal assembly 532 may include any suitable structure configured to remove water from output stream 536 to produce an at least substantially dried stream 542. For example, water removal assembly 532 may include at least one gas dryer 544 configured to remove at least a substantial portion of water vapor from output stream 536 and to form at least one reclaimed water stream 546 from the removed water vapor. In some embodiments, the water removal assembly may include at least one water knockout device 547 configured to remove at least a substantial portion of liquid water from output stream 536. When refining assembly 514 includes one or more water knockout device(s), those devices may be immediately upstream of (or immediately prior to) the gas dryer(s) and the water extracted by those device(s) may form at least a portion of reclaimed

water stream **546**. In some embodiments, water removal assembly **532** may include a reclaimed water pump **548** configured to move or transport the reclaimed water stream to feedstock delivery system **512**, such as to add or supplement water to water source **516**. The reclaimed water stream(s) also may be sent to one or more other components of refining assembly **514** (such as to heat exchanger(s) **538**, sent to drain, and/or otherwise disposed).

Membrane assembly **534** may include any suitable structure configured to separate at least a portion of carbon oxide gas and/or hydrogen gas from at least substantially dried stream **542** to form a methane-rich stream **550**. The separated carbon oxide gas and/or hydrogen gas may form a byproduct stream **552**, which may be sent to feedstock delivery system **512**, one or more heating assemblies of methane-producing assembly **528**, and/or other components of refining assembly **512**. For example, membrane assembly **534** may include one or more carbon oxide selective membranes **554** that are configured to separate carbon oxide gas and/or hydrogen gas from stream(s) **542**. Membrane assembly **534** may include any suitable number of membranes **554**, as shown in dashed lines in FIG. **24**. When membrane assembly **534** includes two or more membranes **554**, those membranes may be arranged in parallel or in series. In some embodiments, membrane assembly **534** may include a shell or housing **555**, which may include any suitable structure configured to at least partially contain membranes **554**. In some embodiments, shell **555** may include insulation and/or a jacket.

Refining assembly **510** may, in some embodiments, include a control system **556**, which may include any suitable structure configured to control operation of the refining assembly. For example, control system **556** may include a control assembly **558**, one or more flow measurement devices **560**, one or more temperature measurement devices **562**, and one or more control valves **564**, as shown in FIG. **24**. Control assembly **558** may detect flow rate of rich natural gas stream **524** and adjust delivery (such as the flow rate) of water stream **522** based, at least in part, on the detected flow rate. Additionally, control assembly **558** may detect temperatures in the HHR reactor via temperature measurement devices **562** (such as thermocouples and/or other suitable devices) and adjust flow rate of the fuel stream(s) and/or byproduct fuel stream(s) to the heating assembly of that reactor via control valves **564** and/or adjust flow rate of the air stream(s) by controlling speed of the air blower(s) of that heating assembly, based, at least in part, on the detected temperature(s).

An example of a plate burner **566** is shown in FIG. **25**, which may be used in one or more heating assemblies described in this disclosure. For example, plate burner **566** may be positioned adjacent to (or to the side of) a vaporizer. Plate burner **566** may include any suitable structure configured to receive at least one fuel stream **568** and to distribute that stream for combustion. For example, plate burner **566** may include a non-porous (or solid) frame **570** and first and second opposed plates **572**, **574**. Frame **570** may include at least one inlet or input port **576** configured to receive the at least one fuel stream. The frame and the first and second plates may define an interior **577**. The inlet(s) may be fluidly connected to the interior. One or both of the first and second plates may be porous and/or may include a plurality of outlets **578**, arranged orderly or randomly, for the at least one fuel stream. In use, one or more air blowers may be positioned adjacent to the first and/or second plates such that one or more air streams flow toward the fuels streams

discharged from outlets **578** (such as flowing toward and about perpendicular to those fuel streams).

An example of a method of refining rich natural gas containing a first methane gas and other hydrocarbons that are heavier than methane gas is shown in FIG. **26** and is generally indicated at **600**. Although particular steps are shown in FIG. **26**, other examples of method **600** may omit, modify, duplicate, and/or add one or more steps. Additionally, the steps may be performed in any suitable sequence.

At step **602**, at least a substantial portion of other hydrocarbons of the rich natural gas may be converted with water to an output stream containing a second methane gas, a lesser portion of the water, hydrogen gas, and/or carbon oxide gas (such as carbon dioxide gas and/or carbon monoxide gas). In some embodiments, converting at least a substantial portion of the other hydrocarbons may include not converting at least a substantial portion of the first methane gas from the rich natural gas. In other words, at least a substantial portion of the first methane gas may be allowed to pass through without conversion and/or reaction. In some embodiments, converting at least a substantial portion of the other hydrocarbons may include heating the rich natural gas and the water to a minimum methane-producing temperature in at least one heating assembly and/or feeding at least a portion of at least one byproduct stream to the heating assembly.

At step **604**, at least a portion of the water from the output stream may be removed to produce an at least substantially dried stream. The water may be in the form of water vapor and/or liquid water.

At step **606**, at least a portion of carbon oxide gas and at least a portion of hydrogen gas from the at least substantially dried stream may be converted to methane gas to form an intermediate stream therefrom containing a lower concentration of hydrogen gas and carbon oxide gas compared to the at least substantially dried stream. Step **606** may be performed once or may be repeated any suitable number of times, such as two, three, four, or more. In some embodiments, step **606** may be omitted.

At step **608**, at least a portion of carbon oxide gas (and/or at least a portion of hydrogen gas) may be separated to form a byproduct stream therefrom. The remaining portion of the intermediate stream may form at least part of a methane-rich stream having a greater methane concentration than the intermediate stream. In some embodiments, at least a portion of the byproduct stream may be used as fuel for one or more heating steps of method **600**. In some embodiments, separating at least a portion of the carbon oxide gas may include allowing at least a portion of the carbon oxide gas to pass from a feed side to a permeate side of at least one carbon oxide selective membrane. In some embodiments, separating at least a portion of the carbon oxide gas may include flowing at least one liquid absorbent stream through the permeate side of the at least one carbon oxide selective membrane to produce therefrom a liquid absorbent stream having absorbed carbon oxide gas (or spent liquid absorbent stream). In some embodiments, separating at least a portion of the carbon oxide gas may include detecting pressure of the intermediate stream, detecting pressure of the spent liquid absorbent stream, and/or controlling flow of the spent liquid absorbent stream such that the pressure of that liquid absorbent stream is greater than the pressure of the intermediate stream in the feed side of the at least one carbon oxide selective membrane. In some embodiments, separating at least a portion of the carbon oxide gas may include heating the spent liquid absorbent stream to strip at least a substantial portion of the absorbed carbon oxide gas to form

35

a stripped liquid absorbent stream and an offgas stream containing the stripped carbon oxide gas.

Refining assemblies of the present disclosure may include one or more of the following:

A methane-producing assembly configured to receive at least one liquid-containing feed stream that includes water and rich natural gas.

A methane-producing assembly configured to receive rich natural gas and at least one liquid-containing feed stream that includes water.

A methane-producing assembly configured to produce an output stream by (a) converting at least a substantial portion of other hydrocarbons of a rich natural gas with water to a second methane gas, a lesser portion of the water, and other gases; and/or (b) allowing at least a substantial portion of a first methane gas from the rich natural gas to pass through the methane-producing assembly unconverted.

A vaporizer configured to receive and/or vaporize at least a portion of at least one liquid-containing feedstream that includes water with or without rich natural gas to form an at least substantially vaporized stream.

A methane-producing reactor containing a catalyst.

A methane-producing reactor configured to receive an at least substantially vaporized stream and/or a rich natural gas stream.

A methane-producing reactor configured to produce an output stream by (a) converting at least a substantial portion of other hydrocarbons with water to a second methane gas, a lesser portion of the water, and other gases; and (b) allowing at least a substantial portion of a first methane gas from rich natural gas to pass through the methane-producing reactor unconverted.

A heating assembly configured to produce a heated exhaust stream for heating at least one of a vaporizer to at least a minimum vaporization temperature and/or a methane-producing reactor to at least a minimum methane-producing temperature.

A heating assembly including a frame and first and second opposed plates attached to the frame and defining an interior therebetween.

A frame that includes one or more inlets that are fluidly connected to an interior and that are for receiving at least one fuel stream.

One or both of first and second plates include openings defining a plurality of outlets for at least one fuel stream.

A purification assembly configured to receive an output stream.

A purification assembly configured to produce a methane-rich stream having a greater methane concentration than the output stream.

At least one gas dryer configured to remove at least a substantial portion of water vapor from an output stream to produce an at least substantially dried stream.

At least one water knockout device configured to remove at least a substantial portion of liquid water from an output stream.

A purification assembly configured to convert at least a portion of carbon oxide gas and at least a portion of hydrogen gas in an at least substantially dried stream to methane gas, and to produce an intermediate stream therefrom.

At least one synthetic natural gas (SNG) reactor containing a catalyst.

At least one SNG reactor configured to convert at least a portion of carbon oxide gas and at least a portion of

36

hydrogen gas in an at least substantially dried stream to methane gas, and to produce an intermediate stream therefrom.

A heating assembly configured to produce a heated exhaust stream for heating at least one SNG reactor to a minimum conversion temperature.

A purification assembly configured to separate at least a portion of carbon oxide gas from an intermediate stream, and to produce a byproduct stream therefrom.

At least one absorber configured to receive at least one absorbent that is adapted to absorb at least a portion of carbon oxide gas from an intermediate stream, and to produce a byproduct stream therefrom.

At least one absorber configured to receive a liquid absorbent stream that is adapted to absorb at least a portion of carbon oxide gas, and/or direct flow of an intermediate stream through the liquid absorbent stream.

At least one absorber configured to receive at least one solid absorbent that is adapted to absorb carbon oxide gas, and/or to direct flow of an intermediate stream through the at least one solid absorbent.

At least one stripper configured to (a) receive a liquid absorbent stream with absorbed carbon oxide gas, (b) strip the carbon oxide gas from that liquid absorbent stream to form an offgas stream therefrom, and/or (c) deliver the stripped liquid absorbent stream to at least one absorber.

At least one carbon oxide selective membrane having a feed side and a permeate side.

A feed side configured to receive an intermediate stream. At least a portion of carbon oxide gas in an intermediate stream is configured to pass from a feed side to a permeate side.

A remaining portion of an intermediate stream that remains on a feed side forms at least part of a methane-rich stream.

A permeate side configured to receive a liquid absorbent stream that is adapted to absorb at least a portion of carbon oxide gas that passes from a feed side to a permeate side.

At least one stripper configured to (a) receive a liquid absorbent stream with absorbed carbon oxide gas, (b) strip the carbon oxide gas from that liquid absorbent stream to form a byproduct stream therefrom, and/or (c) deliver the stripped liquid absorbent stream to a permeate side of at least one carbon oxide selective membrane.

Methods of refining rich natural gas may include one or more of the following:

Receiving at least one liquid-containing feed stream that includes water and rich natural gas.

Receiving rich natural gas and at least one liquid-containing feed stream that includes water.

Vaporizing at least one liquid-containing feed stream that includes water with or without rich natural gas to form an at least substantially vaporized stream.

Receiving an at least substantially vaporized stream and/or a rich natural gas stream.

Converting at least a substantial portion of other hydrocarbons of rich natural gas with water to an output stream containing a second methane gas, a lesser portion of the water, hydrogen gas, and carbon oxide gas.

Not converting at least a substantial portion of first methane gas from rich natural gas.

Heating rich natural gas and water to a minimum methane-producing temperature via a heating assembly.

Feeding at least a portion of a byproduct stream to a heating assembly.

Removing at least a portion of water from an output stream to produce an at least substantially dried stream therefrom.

Converting at least a portion of carbon oxide gas and at least a portion of hydrogen gas from an at least substantially dried stream to methane gas to form an intermediate stream therefrom containing a lower concentration of hydrogen gas and carbon oxide gas to the at least substantially dried stream.

Separating, from an intermediate stream, at least a portion of carbon oxide gas to form a byproduct stream therefrom, wherein the remaining portion of the intermediate stream forms at least part of a methane-rich stream having a greater methane concentration than the intermediate stream.

Allowing at least a portion of carbon oxide gas to pass from a feed side to a permeate side of at least one carbon oxide selective membrane.

Flowing a liquid absorbent stream through a permeate side of at least one carbon oxide selective membrane to produce a liquid absorbent stream having absorbed carbon oxide gas.

Detecting pressure of an intermediate stream.

Detecting pressure of a liquid absorbent stream having absorbed carbon oxide gas.

Controlling flow of a liquid absorbent stream having absorbed carbon oxide gas such that the pressure of that liquid absorbent stream in a permeate side of at least one carbon oxide selective membrane is greater than a pressure of an intermediate stream in a feed side of at least one carbon oxide selective membrane.

Heating a liquid absorbent stream having absorbed carbon oxide gas to strip at least a substantial portion of absorbed carbon oxide gas to form a stripped liquid absorbent stream and an offgas stream containing stripped carbon oxide gas.

INDUSTRIAL APPLICABILITY

The present disclosure, including refining assemblies for rich natural gas, and components of those assemblies, is applicable to the fuel-processing and other industries in which methane gas is purified, produced, and/or utilized, such as for fueling an engine and/or electrical power generation.

The disclosure set forth above encompasses multiple distinct inventions with independent utility. While each of these inventions has been disclosed in its preferred form, the specific embodiments thereof as disclosed and illustrated herein are not to be considered in a limiting sense as numerous variations are possible. The subject matter of the inventions includes all novel and non-obvious combinations and subcombinations of the various elements, features, functions and/or properties disclosed herein. Similarly, where any claim recites "a" or "a first" element or the equivalent thereof, such claim should be understood to include incorporation of one or more such elements, neither requiring nor excluding two or more such elements.

Inventions embodied in various combinations and sub-combinations of features, functions, elements, and/or properties may be claimed through presentation of new claims in a related application. Such new claims, whether they are directed to a different invention or directed to the same invention, whether different, broader, narrower or equal in

scope to the original claims, are also regarded as included within the subject matter of the inventions of the present disclosure.

What is claimed is:

1. A refining assembly for rich natural gas containing a first methane gas and other hydrocarbons that are heavier than methane gas, comprising:

a methane-producing assembly configured to receive at least one liquid-containing feed stream that includes water and rich natural gas and to produce an output stream therefrom by (a) converting at least a substantial portion of the other hydrocarbons of the rich natural gas with the water to a second methane gas, a lesser portion of the water, and other gases, and (b) allowing at least a substantial portion of the first methane gas from the rich natural gas to pass through the methane-producing assembly unconverted; and

a purification assembly configured to receive the output stream and to produce a methane-rich stream therefrom having a greater methane concentration than the output stream,

where the output stream includes water vapor, wherein the purification assembly includes at least one gas dryer configured to remove at least a substantial portion of the water vapor from the output stream to produce an at least substantially dried stream, and

where the other gases in the output stream includes carbon oxide gas and hydrogen gas, wherein the purification assembly is configured to convert at least a portion of the carbon oxide gas and at least a portion of the hydrogen gas in the at least substantially dried stream to methane gas, and to produce an intermediate stream therefrom.

2. The refining assembly of claim 1, wherein the purification assembly includes:

at least one synthetic natural gas (SNG) reactor containing a catalyst and configured to convert at least a portion of the carbon oxide gas and at least a portion of the hydrogen gas in the at least substantially dried stream to methane gas, and to produce the intermediate stream therefrom; and

a heating assembly configured to produce a heated exhaust stream for heating the at least one SNG reactor to a minimum conversion temperature.

3. The refining assembly of claim 2, wherein the heating assembly includes:

a frame; and
first and second opposed plates attached to the frame and defining an interior therebetween, wherein the frame includes one or more inlets that are fluidly connected to the interior and that are for receiving at least one fuel stream, and one or both of the first and second plates include openings defining a plurality of outlets for the at least one fuel stream.

4. The refining assembly of claim 2, wherein the purification assembly is further configured to separate at least a portion of carbon oxide gas from the intermediate stream, and to produce a byproduct stream therefrom.

5. The refining assembly of claim 4, wherein the purification assembly includes at least one absorber configured to receive at least one absorbent that is adapted to absorb at least a portion of carbon oxide gas from the intermediate stream, and to produce the byproduct stream therefrom.

6. The refining assembly of claim 5, wherein the at least one absorber is configured to (a) receive a liquid absorbent stream that is adapted to absorb at least a portion of carbon oxide gas, and (b) direct flow of the intermediate stream through the liquid absorbent stream.

39

7. The refining assembly of claim 6, wherein the purification assembly further includes at least one stripper configured to (a) receive the liquid absorbent stream with absorbed carbon oxide gas, (b) strip the carbon oxide gas from that liquid absorbent stream to form an offgas stream therefrom, and (c) deliver the stripped liquid absorbent stream to the at least one absorber.

8. The refining assembly of claim 5, where the at least one absorber is configured to receive at least one solid absorbent that is adapted to absorb carbon oxide gas, and to direct flow of the intermediate stream through the at least one solid absorbent.

9. The refining assembly of claim 4, wherein the purification assembly includes at least one carbon oxide selective membrane having a feed side and a permeate side, the feed side is configured to receive the intermediate stream, at least a portion of the carbon oxide gas in the intermediate stream is configured to pass from the feed side to the permeate side, and the remaining portion of the intermediate stream that remains on the feed side forms at least part of the methane-rich stream.

10. The refining assembly of claim 9, wherein the permeate side is configured to receive a liquid absorbent stream that is adapted to absorb at least a portion of the carbon oxide gas that passes from the feed side to the permeate side.

11. The refining assembly of claim 10, wherein the purification assembly further includes at least one stripper configured to (a) receive the liquid absorbent stream with the absorbed carbon oxide gas, (b) strip the carbon oxide gas from that liquid absorbent stream to form a byproduct stream therefrom, and (c) deliver the stripped liquid absorbent stream to the permeate side of the at least one carbon oxide selective membrane.

12. The refining assembly of claim 11, wherein the methane-producing assembly includes:

a vaporizer configured to receive and vaporize at least a portion of the at least one liquid-containing feedstream that includes water and rich natural gas to form an at least substantially vaporized stream;

a methane-producing reactor containing a catalyst and configured to receive the vaporized feed stream and to produce the output stream by (a) converting at least a substantial portion of the other hydrocarbons with the water to the second methane gas, a lesser portion of the water, and the other gases and (b) allowing at least a substantial portion of the first methane gas from the rich natural gas stream to pass through the methane-producing reactor unconverted; and

a heating assembly configured to receive at least one fuel stream and at least one air stream to produce a heated exhaust stream for heating at least one of the vaporizer to at least a minimum vaporization temperature or the methane-producing reactor to at least a minimum methane-producing temperature, and wherein at least a portion of the byproduct stream forms at least part of the at least one fuel stream.

13. A refining assembly for rich natural gas containing a first methane gas and other hydrocarbons that are heavier than methane gas, comprising:

a methane-producing assembly configured to receive at least one liquid-containing feed stream that includes water and rich natural gas and to produce an output stream therefrom by (a) converting at least a substantial portion of the other hydrocarbons of the rich natural gas with the water to a second methane gas, a lesser portion of the water, and other gases, and (b) allowing at least a substantial portion of the first methane gas from the

40

rich natural gas to pass through the methane-producing assembly unconverted; and

a purification assembly configured to receive the output stream and to produce a methane-rich stream therefrom having a greater methane concentration than the output stream,

where the output stream includes water vapor, wherein the purification assembly includes at least one gas dryer configured to remove at least a substantial portion of the water vapor from the output stream to produce an at least substantially dried stream,

where the other gases include carbon oxide gas and hydrogen gas, wherein the purification assembly is further configured to separate at least a portion of the carbon oxide gas and at least a portion of the hydrogen gas from the at least substantially dried stream, and to produce a byproduct stream therefrom, and

wherein the purification assembly includes at least one carbon oxide selective membrane having a feed side and a permeate side, the feed side is configured to receive the dried output stream, at least a portion of the carbon oxide gas and at least a portion of the hydrogen gas are configured to pass from the feed side to the permeate side to produce the byproduct stream therefrom, and the remaining portion of the output stream that remains on the feed side forms at least part of the methane-rich stream.

14. A method of refining rich natural gas containing a first methane gas and other hydrocarbons that are heavier than methane gas, comprising:

converting at least a substantial portion of the other hydrocarbons of the rich natural gas with water to an output stream containing a second methane gas, a lesser portion of the water, hydrogen gas, and carbon oxide gas, wherein converting at least a substantial portion of the other hydrocarbons includes not converting at least a substantial portion of the first methane gas from the rich natural gas;

removing at least a portion of the water from the output stream to produce an at least substantially dried stream therefrom;

converting at least a portion of the carbon oxide gas and at least a portion of the hydrogen gas from the at least substantially dried stream to methane gas to form an intermediate stream therefrom containing a lower concentration of hydrogen gas and carbon oxide gas compared to the at least substantially dried stream; and

separating, from the intermediate stream, at least a portion of the carbon oxide gas to form a byproduct stream therefrom, wherein the remaining portion of the intermediate stream forms at least part of a methane-rich stream having a greater methane concentration than the intermediate stream.

15. The method of claim 14, wherein separating at least a portion of the carbon oxide gas includes allowing at least a portion of the carbon oxide gas to pass from a feed side to a permeate side of at least one carbon oxide selective membrane.

16. The method of claim 15, wherein separating at least a portion of the carbon oxide gas further includes flowing a liquid absorbent stream through the permeate side of the at least one carbon oxide selective membrane to produce therefrom a liquid absorbent stream having absorbed carbon oxide gas.

41

17. The method of claim 16, wherein separating at least a portion of the carbon oxide gas further includes:

detecting pressure of the intermediate stream;
detecting pressure of the liquid absorbent stream having absorbed carbon oxide gas; and

controlling flow of the liquid absorbent stream having absorbed carbon oxide gas such that the pressure of that liquid absorbent stream in the permeate side of the at least one carbon oxide selective membrane is greater than the pressure of the intermediate stream in the feed side of the at least one carbon oxide selective membrane.

18. The method of claim 16, wherein separating at least a portion of the carbon oxide gas further includes heating the liquid absorbent stream having absorbed carbon oxide gas to strip at least a substantial portion of the absorbed carbon oxide gas to form a stripped liquid absorbent stream and an offgas stream containing the stripped carbon oxide gas.

19. The method of claim 14, wherein converting at least a substantial portion of the other hydrocarbons with water includes heating the rich natural gas and the water to a minimum methane-producing temperature via a heating assembly.

20. The method of claim 19, wherein converting at least a substantial portion of the other hydrocarbons includes feeding at least a portion of the byproduct stream to the heating assembly.

21. A refining assembly for rich natural gas containing a first methane gas and other hydrocarbons that are heavier than methane gas, comprising:

a vaporizer configured to receive and vaporize at least a portion of at least one liquid-containing feedstream that includes water and rich natural gas to form an at least substantially vaporized stream;

a methane-producing reactor containing a catalyst and configured to receive the vaporized feed stream and to produce an output stream by (a) converting at least a substantial portion of the other hydrocarbons with the water to a second methane gas, a lesser portion of the water, hydrogen gas, and carbon oxide gas, and (b) allowing at least a substantial portion of the first methane gas from the rich natural gas stream to pass through the methane-producing reactor unconverted;

a first heating assembly configured to receive at least one fuel stream and at least one air stream and produce a heated exhaust stream for heating at least one of the vaporizer to at least a minimum vaporization temperature or the methane-producing reactor to at least a minimum methane-producing temperature;

a purification assembly configured to receive the output stream and to produce a methane-rich stream therefrom having a greater methane concentration than the output stream, wherein the purification assembly includes at least one of a gas dryer or a water knockout device configured to remove at least a substantial portion of water from the output stream to produce an at least substantially dried stream; and

at least one synthetic natural gas (SNG) reactor containing a catalyst and configured to convert at least a portion of the carbon oxide gas and at least a portion of the hydrogen gas in the at least substantially dried stream to methane gas, and to produce an intermediate stream therefrom; and

a second heating assembly configured to produce a heated exhaust stream for heating the at least one SNG reactor to a minimum conversion temperature.

42

22. The refining assembly of claim 21, wherein the purification assembly further includes at least one absorber having at least one absorbent configured to absorb at least a portion of carbon oxide gas from the intermediate stream, and to produce a byproduct stream therefrom.

23. The refining assembly of claim 21, wherein at least a portion of the byproduct stream forms at least part of the at least one fuel stream for the first heating assembly.

24. The refining assembly of claim 21, wherein the purification assembly further includes at least one carbon oxide selective membrane having a feed side and a permeate side, the feed side is configured to receive the intermediate stream, at least a portion of the carbon oxide gas in the intermediate stream is configured to pass from the feed side to the permeate side, and the remaining portion of the intermediate stream that remains on the feed side forms at least part of the methane-rich stream.

25. The refining assembly of claim 24, wherein the permeate side is configured to receive a liquid absorbent stream adapted to absorb at least a portion of the carbon oxide gas that passes from the feed side to the permeate side.

26. A refining assembly for rich natural gas containing a first methane gas and other hydrocarbons that are heavier than methane gas, comprising:

a vaporizer configured to receive and vaporize at least a portion of at least one liquid-containing feedstream that includes water and rich natural gas to form an at least substantially vaporized stream;

a methane-producing reactor containing a catalyst and configured to receive the vaporized feed stream and to produce an output stream by (a) converting at least a substantial portion of the other hydrocarbons with the water to a second methane gas, a lesser portion of the water, hydrogen gas, and carbon oxide gas, and (b) allowing at least a substantial portion of the first methane gas from the rich natural gas stream to pass through the methane-producing reactor unconverted;

a first heating assembly configured to receive at least one fuel stream and at least one air stream and produce a heated exhaust stream for heating at least one of the vaporizer to at least a minimum vaporization temperature or the methane-producing reactor to at least a minimum methane-producing temperature; and

a purification assembly configured to receive the output stream and to produce a methane-rich stream therefrom having a greater methane concentration than the output stream,

wherein the purification assembly includes at least one of a gas dryer or a water knockout device configured to remove at least a substantial portion of water from the output stream to produce an at least substantially dried stream, and

wherein the purification assembly includes at least one carbon oxide selective membrane having a feed side and a permeate side, the feed side is configured to receive the at least substantially dried stream, at least a portion of the carbon oxide gas and at least a portion of the hydrogen gas in the dried output stream are configured to pass from the feed side to the permeate side to produce a byproduct stream therefrom, and the remaining portion of the dried output stream that remains on the feed side forms at least part of the methane-rich stream.

27. The refining assembly of claim 26, wherein at least a portion of the byproduct stream forms at least part of the at least one fuel stream for the first heating assembly.

* * * * *