



(12) **United States Patent**
Batchelder et al.

(10) **Patent No.:** **US 9,586,357 B2**
(45) **Date of Patent:** **Mar. 7, 2017**

(54) **RIBBON FILAMENT AND ASSEMBLY FOR USE IN EXTRUSION-BASED DIGITAL MANUFACTURING SYSTEMS**

(75) Inventors: **J. Samuel Batchelder**, Somers, NY (US); **William J. Swanson**, St. Paul, MN (US); **S. Scott Crump**, Wayzata, MN (US)

(73) Assignee: **Stratasys, Inc.**, Eden Prairie, MN (US)

(*) Notice: Subject to any disclaimer, the term of this patent is extended or adjusted under 35 U.S.C. 154(b) by 1042 days.

(21) Appl. No.: **13/530,191**

(22) Filed: **Jun. 22, 2012**

(65) **Prior Publication Data**
US 2012/0258190 A1 Oct. 11, 2012

Related U.S. Application Data
(62) Division of application No. 12/612,333, filed on Nov. 4, 2009, now Pat. No. 8,221,669.
(Continued)

(51) **Int. Cl.**
B29C 47/82 (2006.01)
B29C 67/00 (2006.01)
(Continued)

(52) **U.S. Cl.**
CPC **B29C 47/822** (2013.01); **B29C 47/8845** (2013.01); **B29C 67/0055** (2013.01);
(Continued)

(58) **Field of Classification Search**
CPC B22F 3/115; B22F 2998/00; B22F 3/008; B29C 41/36; B29C 67/0055;
(Continued)

(56) **References Cited**

U.S. PATENT DOCUMENTS

4,113,935 A 9/1978 Schippers et al. 526/351
4,639,155 A 1/1987 Schuster et al. 401/1
(Continued)

FOREIGN PATENT DOCUMENTS

GB 816016 7/1959
GB 2291003 A 1/1996
(Continued)

OTHER PUBLICATIONS

The Engineering ToolBox, Modulus of Elasticity or Young's Modulus for some common materials, http://www.engineeringtoolbox.com/young-modulus-d_417.html, copyright 2015, pp. 1-4.*
(Continued)

Primary Examiner — Scott R Walshon
(74) *Attorney, Agent, or Firm* — Westman, Champlin & Koehler, P.A.

(57) **ABSTRACT**

A consumable material for use in an extrusion-based digital manufacturing system, the consumable material comprising a length and a cross-sectional profile of at least a portion of the length that is axially asymmetric. The cross-sectional profile is configured to provide a response time with a non-cylindrical liquefier of the extrusion-based digital manufacturing system that is faster than a response time achievable with a cylindrical filament in a cylindrical liquefier for a same thermally limited, maximum volumetric flow rate.

20 Claims, 9 Drawing Sheets

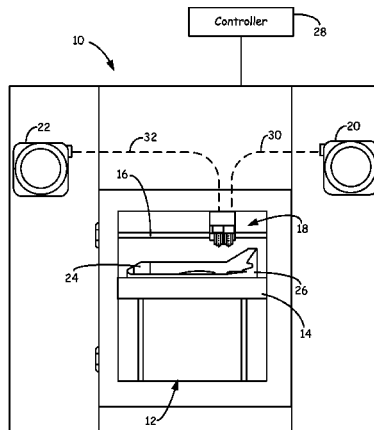

Related U.S. Application Data

- (60) Provisional application No. 61/247,067, filed on Sep. 30, 2009.
- (51) **Int. Cl.**
B29C 47/88 (2006.01)
B29L 7/00 (2006.01)
- (52) **U.S. Cl.**
 CPC *B29L 2007/007* (2013.01); *Y10T 428/2913* (2015.01); *Y10T 428/2929* (2015.01); *Y10T 428/2973* (2015.01)
- (58) **Field of Classification Search**
 CPC . B29C 67/0092; B29C 47/0047; B29C 47/30; B29C 47/065; B29C 47/003; B29C 47/0021; B29C 41/02; B29C 41/34; B29C 67/00; B29C 47/0019; B29C 47/0033; B29C 47/02; B29C 47/0014; B29C 47/822; B29C 47/8845; G05B 19/4099; G05B 19/41; G05B 2219/45238; G05B 2219/49241; Y10T 156/1798; Y10T 156/1038; Y10T 428/24727; Y10T 428/24058; Y10T 428/24132; Y10T 428/24645; Y10T 428/24694; Y10T 428/24702; Y10T 428/24711; B29D 16/00; B29L 2024/00; B29L 2007/007; C04B 35/00; B26F 3/06; B26F 3/08; B26F 1/38; B26F 1/3806; B26D 7/10
 USPC 428/105, 114, 176, 182, 183, 184, 186; 264/177 R, 167, 173, 168, 288.4, 239, 264/401, 482, 489, 234, 308, 317, 255, 264/497, 603, 604, 678; 156/244.11, 156/73.1, 167, 510, 580.1; 239/135, 133, 239/227; 700/119, 109; 228/180.5, 4.5; 83/171, 565, 76.8, 76.1, 76.6, 76.7, 76.9, 83/701, 956, 170; 364/468.26, 468.25; 425/113, 375; 219/121.63
 See application file for complete search history.

6,022,207	A	2/2000	Dahlin et al.	425/145
6,054,077	A	4/2000	Comb et al.	264/40.7
6,067,480	A	5/2000	Stuffle et al.	700/109
6,070,107	A	5/2000	Lombardi et al.	700/119
6,085,957	A	7/2000	Zinniel et al.	226/8
6,129,872	A	10/2000	Jang	264/75
6,153,034	A *	11/2000	Lipsker	156/73.1
6,228,923	B1	5/2001	Lombardi et al.	
6,257,517	B1	7/2001	Babish et al.	242/365.6
6,302,309	B1	10/2001	Drader	226/193
6,459,069	B1 *	10/2002	Rabinovich	219/121.63
6,547,995	B1	4/2003	Comb	264/40.1
6,645,412	B2	11/2003	Priedeman, Jr.	264/219
6,685,866	B2	2/2004	Swanson et al.	264/308
6,722,872	B1	4/2004	Swanson et al.	425/225
6,730,252	B1	5/2004	Teoh et al.	264/178
6,749,414	B1	6/2004	Hanson et al.	425/130
6,790,403	B1	9/2004	Priedeman, Jr. et al.	264/442
6,814,907	B1	11/2004	Comb	264/40.07
6,866,807	B2 *	3/2005	Comb et al.	264/255
6,869,559	B2	3/2005	Hopkins	264/489
6,923,634	B2	8/2005	Swanson et al.	425/169
6,998,087	B1	2/2006	Hanson et al.	264/308
7,122,246	B2	10/2006	Comb et al.	428/364
7,172,715	B2	2/2007	Swanson et al.	264/39
7,363,686	B2	4/2008	Fukuyasu et al.	24/30.5
8,221,669	B2	7/2012	Batchelder et al.	264/308
2005/0101684	A1 *	5/2005	You	B29C 67/0055 522/1
2007/0003656	A1	1/2007	LaBossiere	425/375
2007/0228590	A1	10/2007	LaBossiere et al.	264/40.1
2008/0213419	A1 *	9/2008	Skubic et al.	425/113
2009/0035405	A1	2/2009	Leavitt	425/97
2009/0263582	A1 *	10/2009	Batchelder	427/256
2009/0273122	A1	11/2009	Batchelder et al.	264/401
2009/0274540	A1	11/2009	Batchelder et al.	414/431
2010/0096072	A1	4/2010	Hopkins et al.	156/155
2010/0096485	A1	4/2010	Taatjes et al.	242/171
2010/0096489	A1	4/2010	Taatjes et al.	242/520
2011/0076495	A1	3/2011	Batchelder et al.	428/369

FOREIGN PATENT DOCUMENTS

WO	WO-9737810	10/1997
WO	WO-2007130229	A2 11/2007

OTHER PUBLICATIONS

International Search Report and Written Opinion dated Dec. 14, 2010 from International Patent Application No. PCT/US2010/049607, filed Sep. 21, 2010.
 Techspan Group, "Technical Data Sheet—Techspan Plastic Welding Rods", dated Dec. 31, 2007, retrieved from URL:<http://www.techspanonline.com/data/media/documents/pdf/7.%20TechspanRodList2007.pdf>, retrieved Nov. 4, 2010.
 Examiner's Report dated Dec. 27, 2012 from Canadian Patent Application No. 2,775,076.
 Adrian Bowyer, Drink Bottle Feedstock, Mar. 15, 2009, at <http://blog.reprap.org/2009/03/drink-bottle-feedstock.html>.
 Elastic Properties and Young Modulus for some Materials, http://www.engineeringtoolbox.com/young-modulus-d_417.html, web.archive.org snapshot from Feb. 18, 2007.†

* cited by examiner
 † cited by third party

(56) **References Cited**

U.S. PATENT DOCUMENTS

4,749,347	A	6/1988	Valavaara	425/135
4,797,313	A	1/1989	Stolk et al.	428/156
5,121,329	A *	6/1992	Crump	700/119
5,169,081	A	12/1992	Coedderz	242/54
5,303,141	A	4/1994	Batchelder et al.	364/149
5,312,224	A	5/1994	Batchelder et al.	415/73
5,340,433	A	8/1994	Crump	156/578
5,342,687	A	8/1994	Iwai et al.	428/402
5,503,785	A	4/1996	Crump et al.	264/40.7
5,578,227	A *	11/1996	Rabinovich	B23K 26/34 156/180
5,738,817	A	4/1998	Danforth et al.	264/603
5,764,521	A	6/1998	Batchelder et al.	364/475.01
5,866,058	A	2/1999	Batchelder et al.	264/237
5,939,008	A	8/1999	Comb et al.	264/308
5,968,561	A	10/1999	Batchelder et al.	425/375
6,004,124	A	12/1999	Swanson et al.	425/375

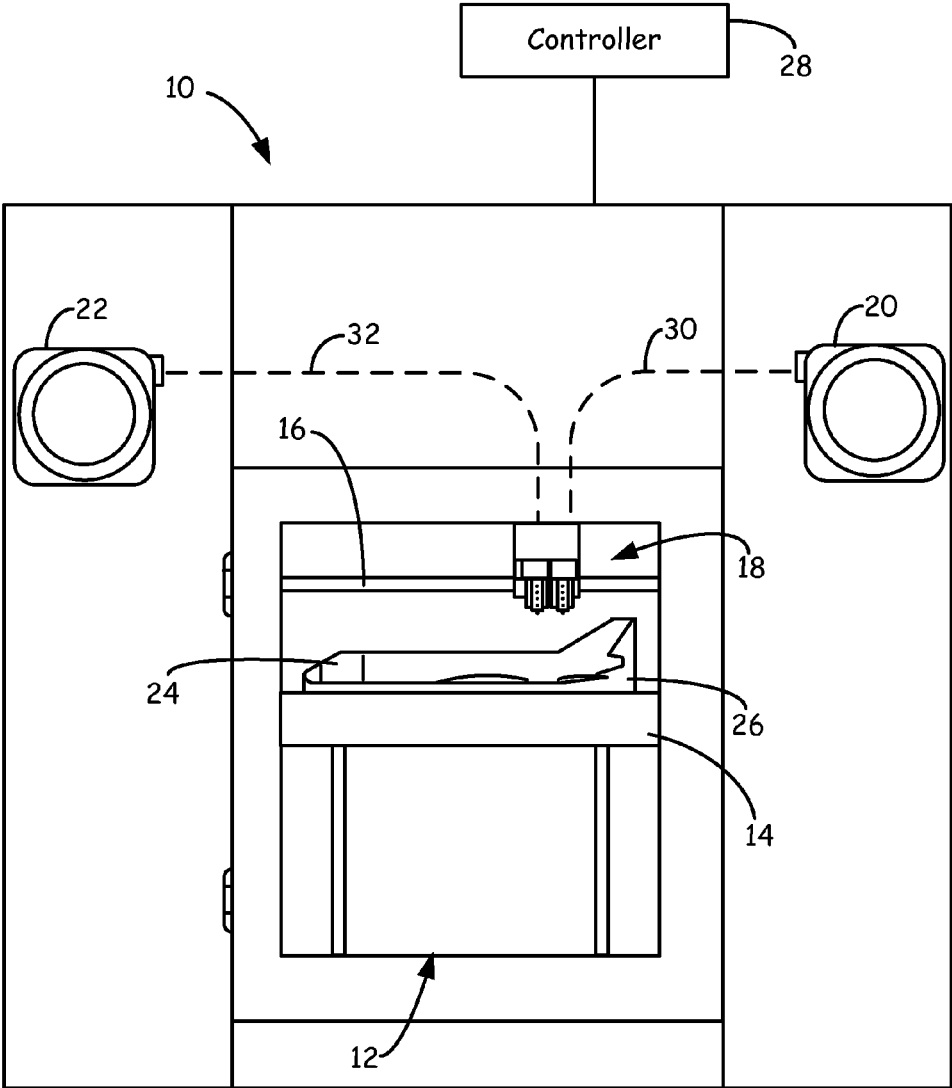
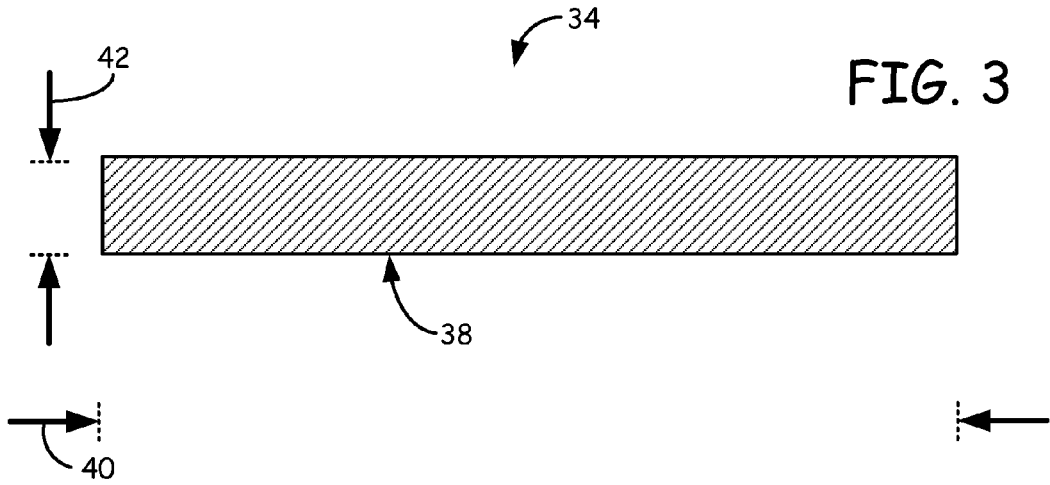
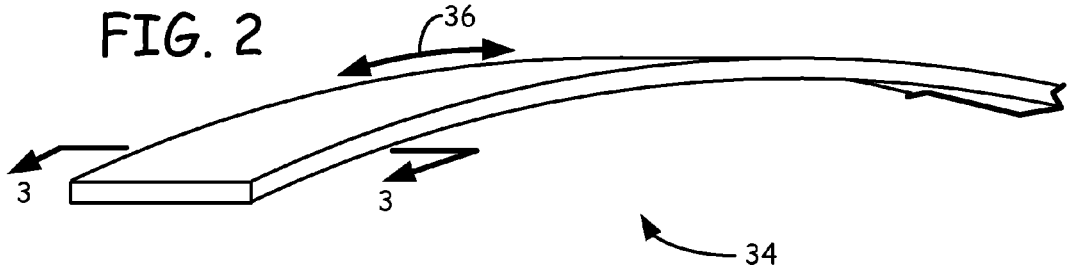

FIG. 1



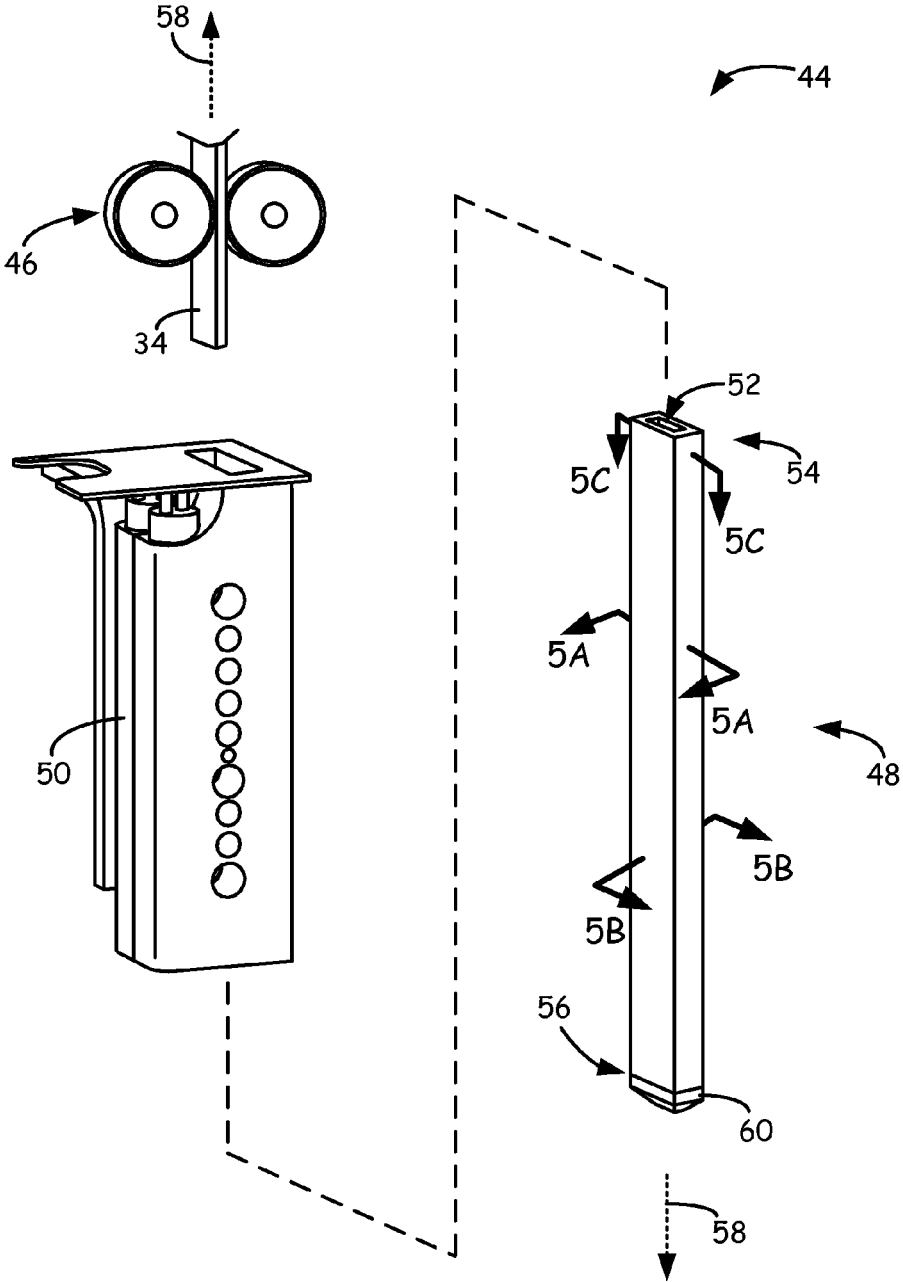

FIG. 4

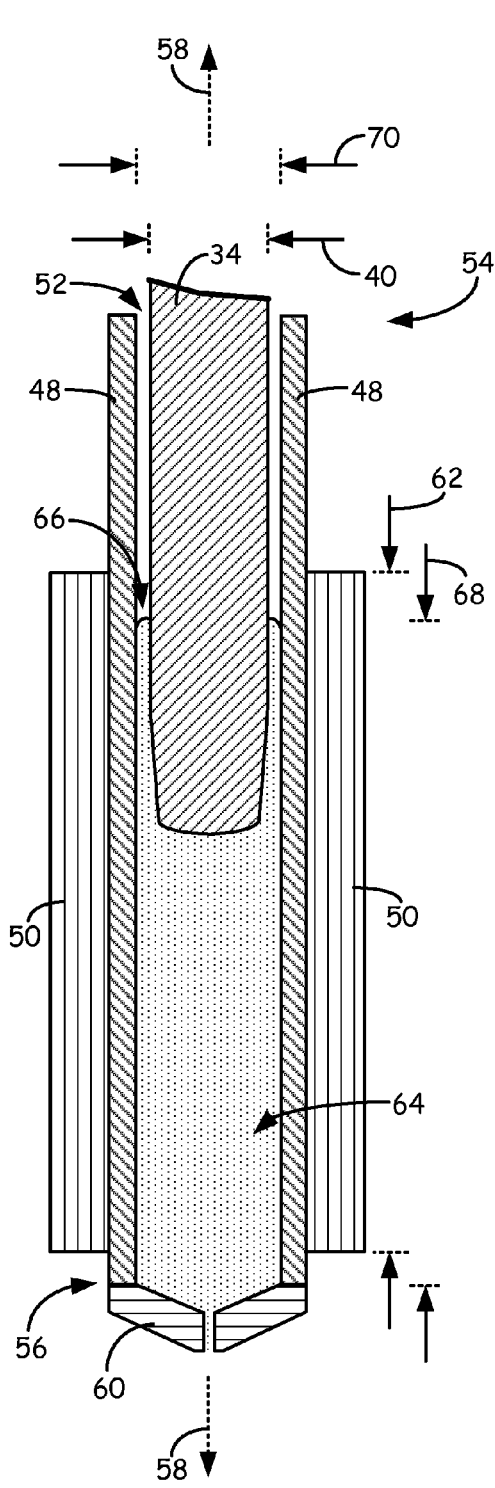

FIG. 5A

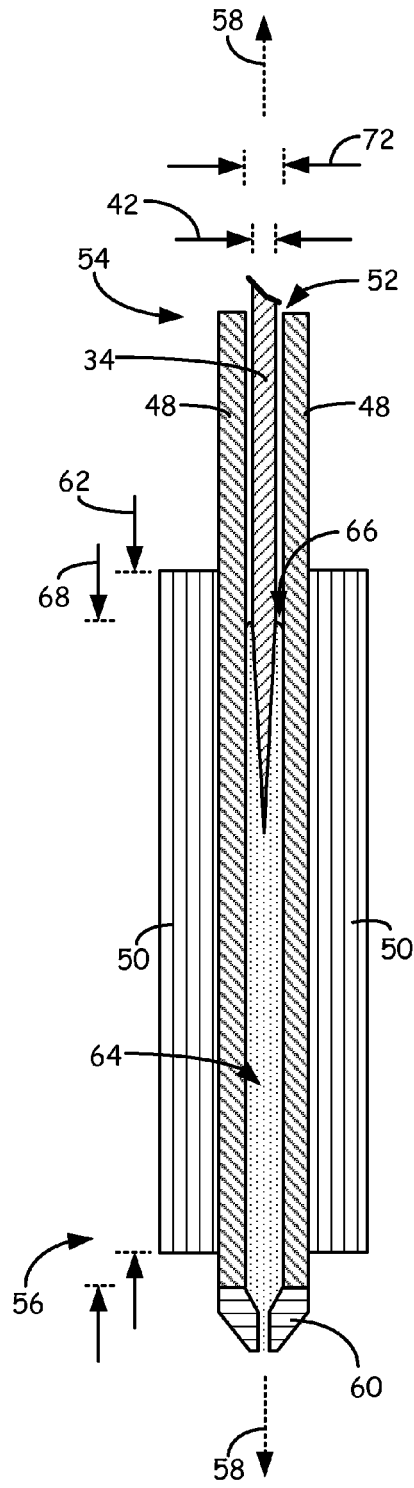

FIG. 5B

FIG. 5C

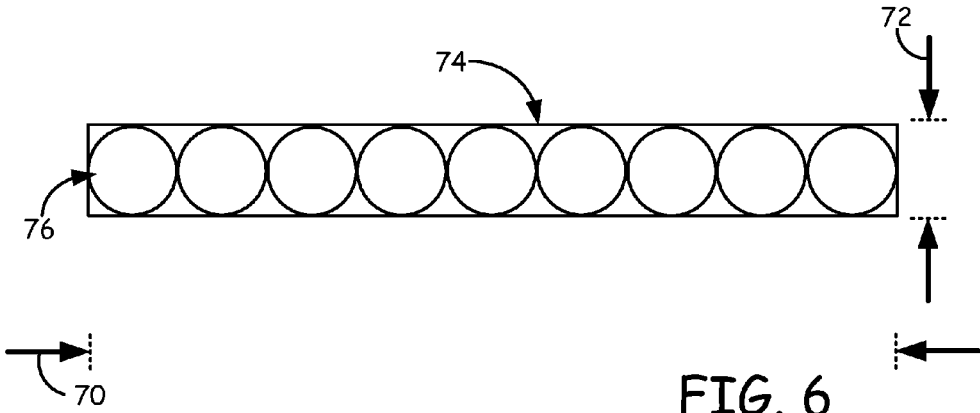
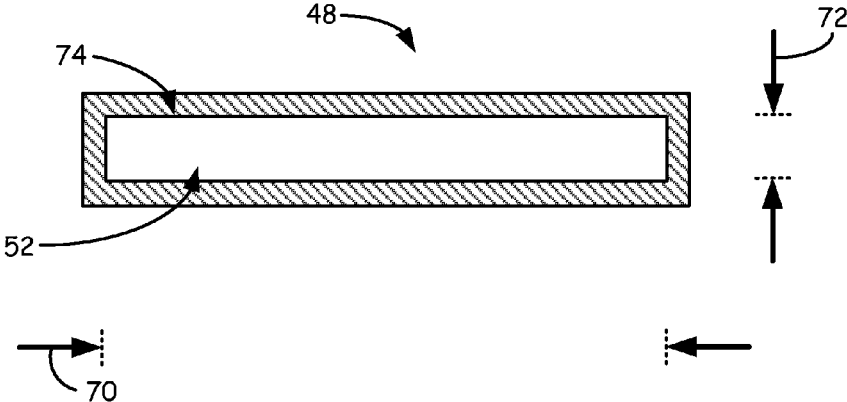

FIG. 6

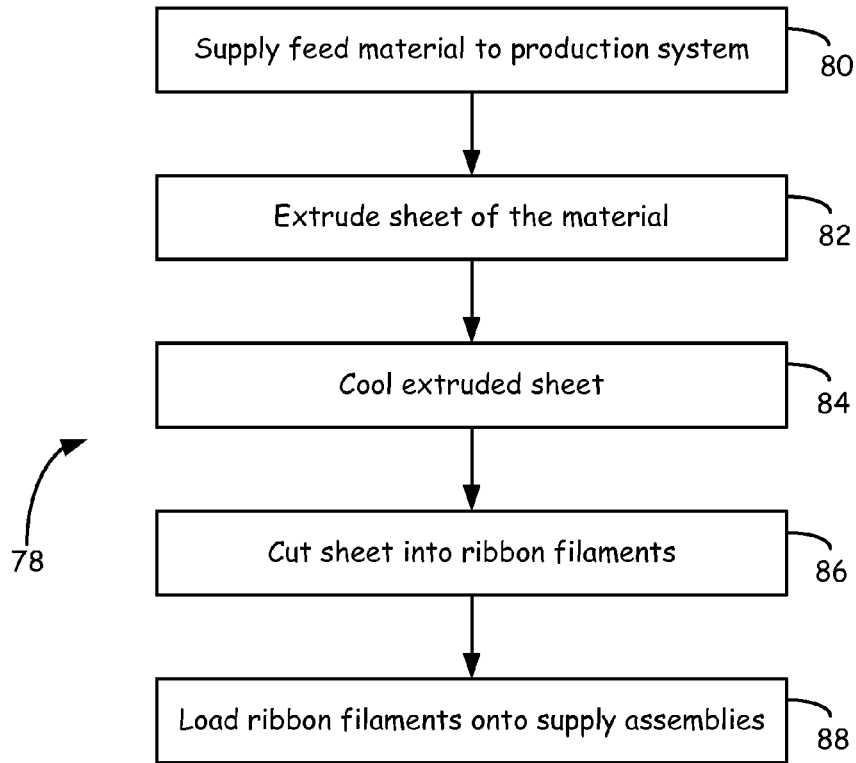

FIG. 7

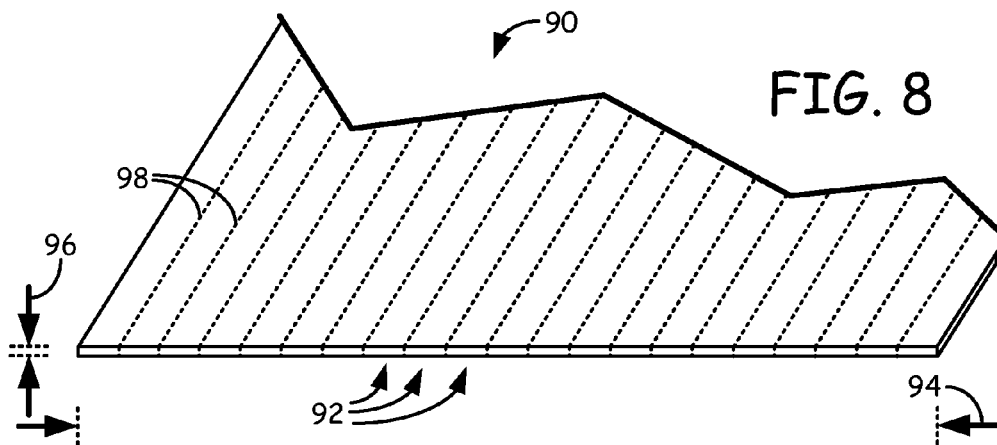

FIG. 8

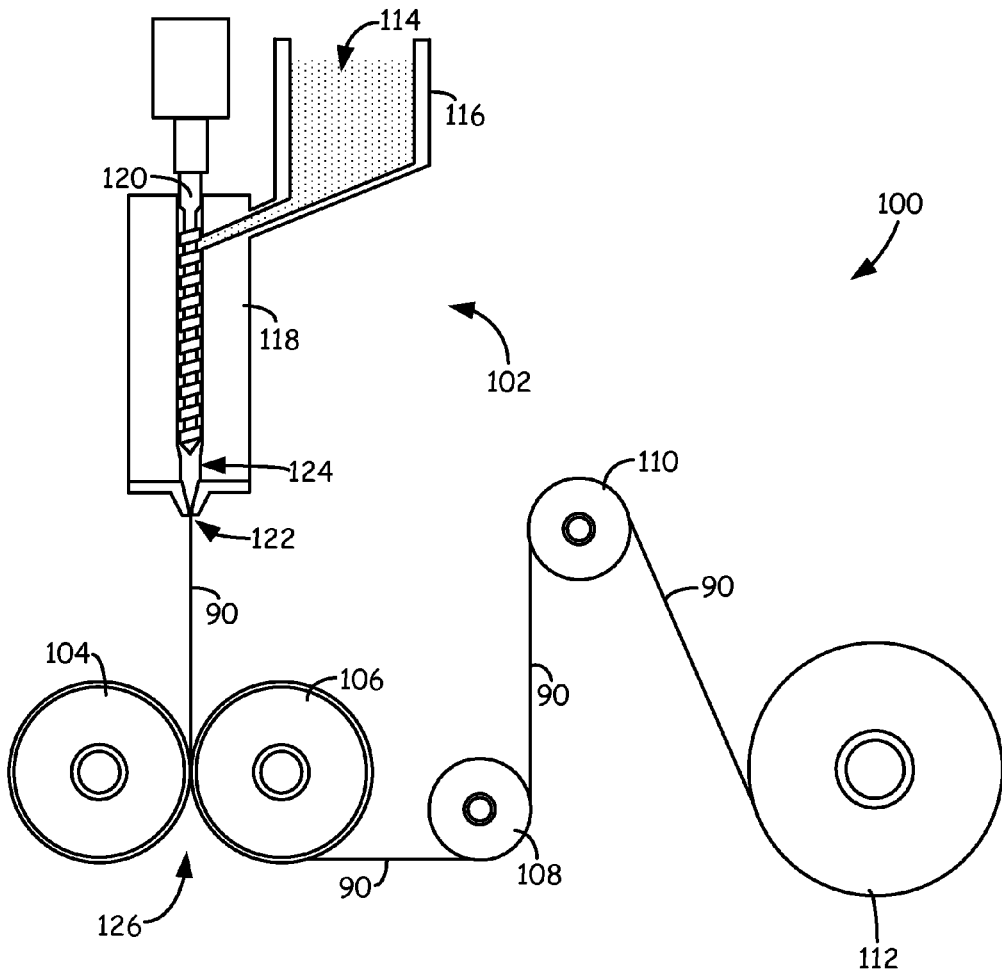
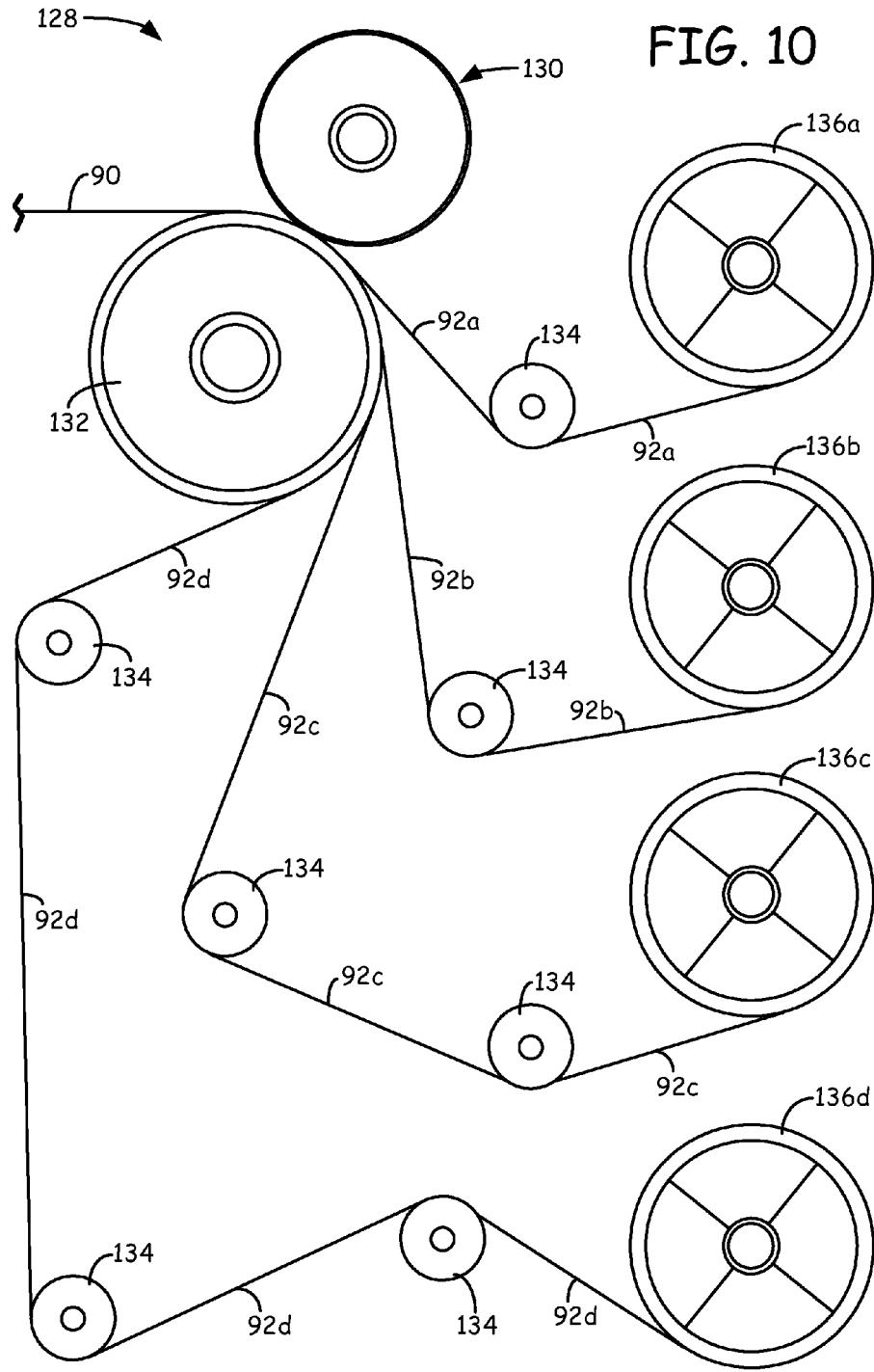

FIG. 9



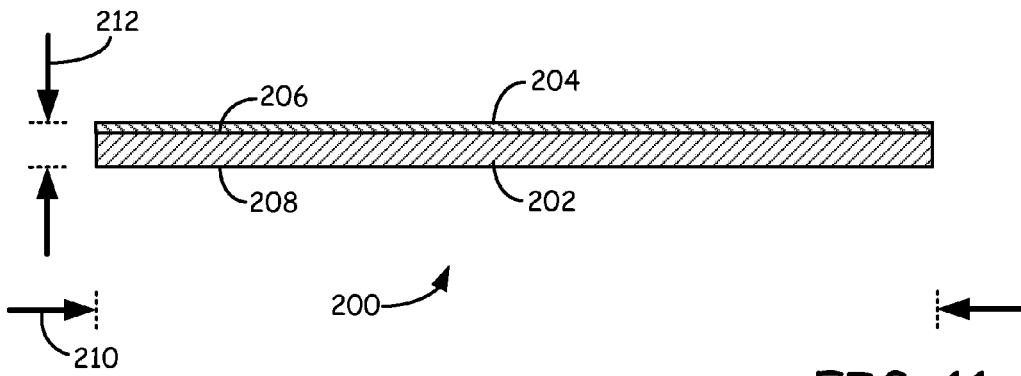

FIG. 11

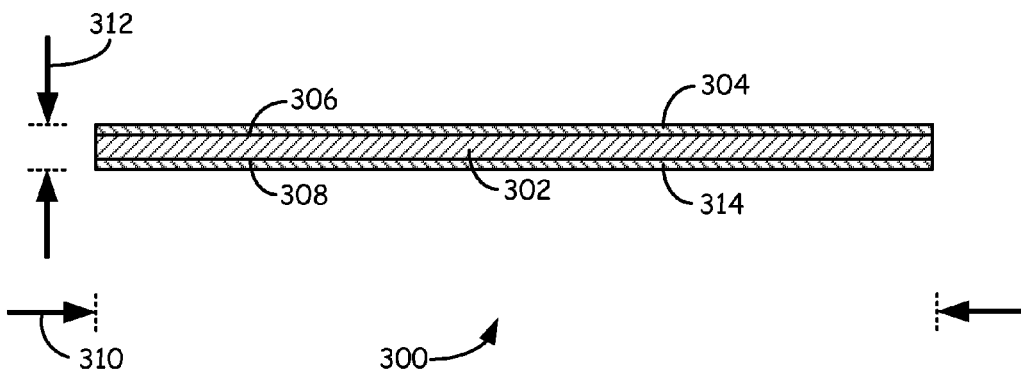

FIG. 12

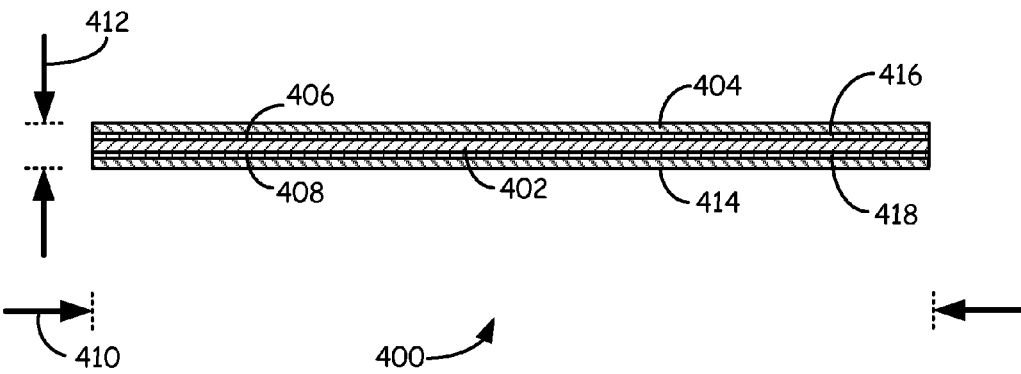

FIG. 13

RIBBON FILAMENT AND ASSEMBLY FOR USE IN EXTRUSION-BASED DIGITAL MANUFACTURING SYSTEMS

CROSS-REFERENCE TO RELATED APPLICATION(S)

This is a divisional application of U.S. patent application Ser. No. 12/612,333, filed on Nov. 4, 2009, and entitled "Non-Cylindrical Filament For Use In Extrusion-Based Digital Manufacturing Systems"; which claims priority to U.S. Provisional Patent Application No. 61/247,067, filed on Sep. 30, 2009, and entitled "Non-Cylindrical Filament For Use In Extrusion-Based Digital Manufacturing Systems".

BACKGROUND

The present disclosure relates to direct digital manufacturing systems for building three-dimensional (3D) models. In particular, the present invention relates to consumable materials, such as modeling and support materials, for use in extrusion-based digital manufacturing systems.

An extrusion-based digital manufacturing system (e.g., fused deposition modeling systems developed by Stratasys, Inc., Eden Prairie, Minn.) is used to build a 3D model from a digital representation of the 3D model in a layer-by-layer manner by extruding a flowable consumable modeling material. The modeling material is extruded through an extrusion tip carried by an extrusion head, and is deposited as a sequence of roads on a substrate in an x-y plane. The extruded modeling material fuses to previously deposited modeling material, and solidifies upon a drop in temperature. The position of the extrusion head relative to the substrate is then incremented along a z-axis (perpendicular to the x-y plane), and the process is then repeated to form a 3D model resembling the digital representation.

Movement of the extrusion head with respect to the substrate is performed under computer control, in accordance with build data that represents the 3D model. The build data is obtained by initially slicing the digital representation of the 3D model into multiple horizontally sliced layers. Then, for each sliced layer, the host computer generates a build path for depositing roads of modeling material to form the 3D model.

In fabricating 3D models by depositing layers of a modeling material, supporting layers or structures are typically built underneath overhanging portions or in cavities of objects under construction, which are not supported by the modeling material itself. A support structure may be built utilizing the same deposition techniques by which the modeling material is deposited. The host computer generates additional geometry acting as a support structure for the overhanging or free-space segments of the 3D model being formed. Consumable support material is then deposited from a second nozzle pursuant to the generated geometry during the build process. The support material adheres to the modeling material during fabrication, and is removable from the completed 3D model when the build process is complete.

SUMMARY

A first aspect of the present disclosure is directed to a ribbon filament for use in an extrusion-based digital manufacturing system with a ribbon liquefier to build a three-dimensional model in a layer-by-layer manner. The ribbon filament includes a composition comprising at least one extrudable material, and a length that is continuous for at

least a distance such that the ribbon filament is feedable from a supply source to the ribbon liquefier retained by a moveable head of the extrusion-based digital manufacturing system. The ribbon filament also includes a cross-sectional profile of the length that is axially asymmetric and having a width and a thickness, wherein the width ranges from about 1.0 millimeter to about 10.2 millimeters, where the thickness ranges from about 0.51 millimeters to about 1.0 millimeter, and where the cross-sectional profile of the ribbon filament has a cross-sectional aspect ratio of the width to the thickness ranging from about 2.5:1 to about 20:1. The ribbon filament exhibits a flexibility such that the ribbon filament does not plastically deform or fracture while retained by the supply source or when fed from the supply source to the ribbon liquefier, and a Young's Modulus value ranging from about 1.0 gigapascal to about 5.0 gigapascals.

Another aspect of the present disclosure is directed to an assembly for use in an extrusion-based digital manufacturing system with a ribbon liquefier to build a three-dimensional model in a layer-by-layer manner. The assembly includes a supply source configured to engage the extrusion-based digital manufacturing system, and a ribbon filament retained by the supply source. The ribbon filament includes a composition comprising at least one extrudable material, and a length that is continuous for at least a distance such that the ribbon filament is feedable from the supply source to the ribbon liquefier retained by a moveable head of the extrusion-based digital manufacturing system. The ribbon filament also includes a rectangular cross-sectional profile of the length, which is configured to mate with the ribbon liquefier having an entrance cross-sectional area A_e and a hydraulic diameter D_h with the ribbon filament, where $D_h < 0.95\sqrt{A_e}$, and where the rectangular cross-sectional profile has a width and a thickness with a cross-sectional aspect ratio of the width to the thickness ranging from about 2.5:1 to about 20:1. The ribbon filament exhibits a flexibility such that the ribbon filament does not plastically deform or fracture while retained by the supply source or when fed from the supply source to the ribbon liquefier, and a Young's Modulus value ranging from about 1.0 gigapascal to about 5.0 gigapascals.

Another aspect of the present disclosure is directed to an assembly for use in an extrusion-based digital manufacturing system with a ribbon liquefier to build a three-dimensional model in a layer-by-layer manner. The assembly includes a container configured to engage the extrusion-based digital manufacturing system, a pathway from the container and configured to extend to a ribbon liquefier retainable by a moveable head of the extrusion-based digital manufacturing system, and a ribbon filament at least partially retained within the container and feedable through the pathway from the container to the ribbon liquefier. The ribbon filament includes a composition comprising at least one extrudable material, a length, and a rectangular cross-sectional profile of the length, which is configured to mate with the ribbon liquefier having an entrance cross-sectional area A_e and a hydraulic diameter D_h with the ribbon filament, where $D_h < 0.95\sqrt{A_e}$, and where the rectangular cross-sectional profile has a width and a thickness with a cross-sectional aspect ratio of the width to the thickness ranging from about 2.5:1 to about 20:1. The ribbon filament exhibits a flexibility such that the ribbon filament does not plastically deform or fracture while retained by the supply source or when fed from the supply source to the ribbon liquefier, and a Young's Modulus value ranging from about 1.0 gigapascal to about 5.0 gigapascals.

BRIEF DESCRIPTION OF THE DRAWINGS

FIG. 1 is a front view of an extrusion-based digital manufacturing system for building 3D models and support structures from non-cylindrical filaments of modeling and support materials.

FIG. 2 is a perspective view of a ribbon filament, which is a non-cylindrical filament having a rectangular cross-sectional profile.

FIG. 3 is a sectional view of section 3-3 taken in FIG. 2, illustrating the cross-sectional profile of the ribbon filament.

FIG. 4 is an exploded perspective view of an extrusion head subassembly of the extrusion-based digital manufacturing system in use with a ribbon filament, where the extrusion head subassembly includes a rectangular liquefier.

FIG. 5A is a sectional view of section 5A-5A taken in FIG. 4, illustrating the ribbon filament being extruded through the rectangular liquefier.

FIG. 5B is a sectional view of section 5B-5B taken in FIG. 4, further illustrating the ribbon filament being extruded through the rectangular liquefier.

FIG. 5C is a sectional view of section 5C-5C taken in FIG. 4, illustrating an inlet cross-sectional profile of the rectangular liquefier.

FIG. 6 is a schematic illustration of a plurality of cylindrical liquefiers superimposed over a rectangular liquefier.

FIG. 7 is a flow diagram of a method of forming ribbon filaments.

FIG. 8 is a perspective view of an extruded sheet used to form ribbon filaments.

FIG. 9 is a schematic illustration of a sheet extrusion system for forming the extruded sheet.

FIG. 10 is a schematic illustration of a filament-production system for forming ribbon filaments from extruded sheets.

FIG. 11 is an alternative sectional view of section 3-3 taken in FIG. 2, illustrating a first alternative ribbon filament having a single laminated surface.

FIG. 12 is an alternative sectional view of section 3-3 taken in FIG. 2, illustrating a second alternative ribbon filament having two laminated surfaces.

FIG. 13 is an alternative sectional view of section 3-3 taken in FIG. 2, illustrating a third alternative ribbon filament having two laminated surfaces with multiple layers.

DETAILED DESCRIPTION

The present disclosure is directed to non-cylindrical filaments of modeling and support materials for use in extrusion-based digital manufacturing systems, and methods and systems for manufacturing the non-cylindrical filaments. As discussed below, the non-cylindrical filaments are consumable materials capable of being melted and extruded from non-cylindrical liquefiers with reduced response times compared to cylindrical filaments melted and extruded from cylindrical liquefiers with the same volumetric flow rates. This is beneficial for improving depositional accuracies and reducing build times, thereby increasing process efficiencies for building 3D models and corresponding support structures.

As used herein, the term “non-cylindrical filament” refers to a filament of a modeling or support material having a cross-sectional profile that is non-circular (e.g., a rectangular cross-sectional profile). This is in comparison to a “cylindrical filament”, which has a cross-sectional profile that is circular. Correspondingly, as used herein, the term “non-cylindrical liquefier” refers to a liquefier having a channel

with a cross-sectional profile that is non-circular (e.g., a rectangular or arcuate cross-sectional profile) for receiving a non-cylindrical filament. This is in comparison to a “cylindrical liquefier”, which has a channel with a cross-sectional profile that is circular for receiving a cylindrical filament.

FIG. 1 is a front view of system 10, which is an extrusion-based digital manufacturing system that includes build chamber 12, platen 14, gantry 16, extrusion head 18, and supply sources 20 and 22, where extrusion head 18 is configured to receive and melt successive portions of non-cylindrical filaments (not shown in FIG. 1) during a build operation. Suitable extrusion-based digital manufacturing systems for system 10 include fused deposition modeling systems developed by Stratasys, Inc., Eden Prairie, Minn.

Build chamber 12 is an enclosed environment that contains platen 14, gantry 16, and extrusion head 18 for building a 3D model (referred to as 3D model 24) and a corresponding support structure (referred to as support structure 26). Platen 14 is a platform on which 3D model 24 and support structure 26 are built, and moves along a vertical z-axis based on signals provided from a computer-operated controller (referred to as controller 28). Gantry 16 is a guide rail system configured to move extrusion head 18 in a horizontal x-y plane within build chamber 12 based on signals provided from controller 28. The horizontal x-y plane is a plane defined by an x-axis and a y-axis (not shown in FIG. 1), where the x-axis, the y-axis, and the z-axis are orthogonal to each other. In an alternative embodiment, platen 14 may be configured to move in the horizontal x-y plane within build chamber 12, and extrusion head 18 may be configured to move along the z-axis. Other similar arrangements may also be used such that one or both of platen 14 and extrusion head 18 are moveable relative to each other.

Extrusion head 18 is supported by gantry 16 for building 3D model 24 and support structure 26 on platen 14 in a layer-by-layer manner, based on signals provided from controller 28. Extrusion head 18 includes a pair of non-cylindrical liquefiers (not shown in FIG. 1), where the first non-cylindrical liquefier is configured to receive and melt successive portions of a non-cylindrical, modeling material filament, and the second non-cylindrical liquefier is configured to receive and melt successive portions of a non-cylindrical, support material filament.

The non-cylindrical, modeling material filament may be provided to extrusion head 18 from supply source 20 through pathway 30. Similarly, the non-cylindrical, support material filament may be provided to extrusion head 18 from supply source 22 through pathway 32. System 10 may also include additional drive mechanisms (not shown) configured to assist in feeding the non-cylindrical filaments from supply sources 20 and 22 to extrusion head 18. Supply sources 20 and 22 are sources (e.g., spooled containers) for the non-cylindrical filaments, and are desirably retained at a remote location from build chamber 12. Suitable assemblies for supply sources 20 and 22 include those disclosed in Swanson et al., U.S. Pat. No. 6,923,634; Comb et al., U.S. Pat. No. 7,122,246; and Taatjes et al, U.S. Patent Application Publication Nos. 2010/0096489 and 2010/0096485.

During a build operation, gantry 16 moves extrusion head 18 around in the horizontal x-y plane within build chamber 12, and the non-cylindrical filaments are fed to extrusion head 18. Extrusion head 18 thermally melts the successive portions of the received modeling material filament, thereby allowing the molten material to be extruded to build 3D model 24. Similarly, extrusion head 18 thermally melts the successive portions of the support material filament, thereby allowing the molten material to be extruded to build support

structure 26. The upstream, unmelted portions of the non-cylindrical filaments may each function as a piston with a viscosity-pump action to extrude the molten material out of the respective liquefiers of extrusion head 18.

The extruded modeling and support materials are deposited onto platen 14 to build 3D model 24 and support structure 26 using a layer-based additive technique. Support structure 26 is desirably deposited to provide vertical support along the z-axis for overhanging regions of the layers of 3D model 24. After the build operation is complete, the resulting 3D model 24/support structure 26 may be removed from build chamber 12, and support structure 26 may be removed from 3D model 24.

As discussed below, the cross-sectional profiles of the non-cylindrical filaments and liquefiers allow the non-cylindrical filaments to be melted and extruded from extrusion head 18 with reduced response times compared to cylindrical filaments and liquefiers. This increases process efficiencies in system 10 for building 3D model 24 and support structure 26. For example, reduced response times may increase the accuracy of start and stop locations for deposited roads of modeling and support materials. During a build operation to form a layer of a 3D model (e.g., 3D model 24), an extrusion head (e.g., extrusion head 18) is moved in a horizontal x-y plane and deposits a molten modeling material. After a given deposition pattern is completed, the extrusion head stops depositing the modeling material. This is accomplished by stopping the filament from being fed into the liquefier of the extrusion head, thereby halting the viscosity-pump action of the filament.

However, the response time between when the extrusion head stops feeding the filament to the liquefier and when the modeling material actually stops extruding from the extrusion head is not instantaneous. Instead, there is a delay that is based on factors such as the thermal properties of the liquefier, the composition of the filament, and, as discussed below, the cross-sectional profile of the filament and liquefier channel. Similarly, there is also a response time delay associated with the transition from a zero-flow state to a steady-state flow. Liquefiers and filaments that require large response times increase these delays, thereby potentially decreasing depositional accuracies. Reducing the response times, however, can improve the aesthetic and structural qualities of the resulting 3D model, particularly when building 3D models containing fine features.

For example, a reduced response time for system 10 can gate the acceleration of gantry 16 at suitable locations near the deposition start and stop points. This can increase the ability to hide the seams of each layer, which can increase part quality. Additionally, the response time determines how far gantry 16 can deviate from a constant tangential velocity as gantry 16 travels around a corner in the x-y plane. As a result, a reduced response time allows extrusion head 18 to achieve greater cornering accelerations and decelerations. This can reduce the production times required to build 3D models and support structures, much in the same manner as the cornering capabilities of a race car are important for reducing an overall race time.

For ease of discussion, the following disclosure is made with reference to a non-cylindrical filament having a rectangular cross-sectional profile (referred to as a ribbon filament), and a non-cylindrical liquefier having a corresponding rectangular channel for receiving the ribbon filament. The present disclosure, however, is also applicable to non-cylindrical filaments having a variety of different cross-sectional profiles that reduce response times compared to cylindrical filaments.

FIG. 2 is a perspective view of ribbon filament 34, which is a non-cylindrical filament having a rectangular cross-sectional profile and includes length 36. Length 36 is a continuous length that may vary depending on the amount of ribbon filament 34 remaining in supply source 20 or 22 (shown in FIG. 1). Ribbon filament 34 is desirably flexible along length 36 to allow ribbon filament 34 to be retained in supply sources 20 and 22 (e.g., wound on spools) and to be fed through system 10 (e.g., through pathways 30 and 32) without plastically deforming or fracturing. For example, in one embodiment, ribbon filament 34 is desirably capable of withstanding elastic strains greater than t/r , where “t” is a cross-sectional thickness of ribbon filament 34 in the plane of curvature (e.g., thickness 42, shown in FIG. 3), and “r” is a bend radius (e.g., a bend radius in supply source 20 or 22 and/or a bend radius through pathway 30 or 32).

Ribbon filament 34 may be manufactured from a variety of extrudable modeling and support materials for respectively building 3D model 24 and support structure 26 (shown in FIG. 1). Suitable modeling materials for ribbon filament 34 include polymeric and metallic materials. In some embodiments, suitable modeling materials include materials having amorphous properties, such as thermoplastic materials, amorphous metallic materials, and combinations thereof. Examples of suitable thermoplastic materials for ribbon filament 34 include acrylonitrile-butadiene-styrene (ABS) copolymers, polycarbonates, polysulfones, polyethersulfones, polyphenylsulfones, polyetherimides, amorphous polyamides, modified variations thereof (e.g., ABS-M30 copolymers), polystyrene, and blends thereof. Examples of suitable amorphous metallic materials include those disclosed in U.S. Patent Application Publication No. 2009/0263582.

Suitable support materials for ribbon filament 34 include materials having amorphous properties (e.g., thermoplastic materials) and that are desirably removable from the corresponding modeling materials after 3D model 24 and support structure 26 are built. Examples of suitable support materials for ribbon filament 34 include water-soluble support materials commercially available under the trade designations “WATERWORKS” and “SOLUBLE SUPPORTS” from Stratasy, Inc., Eden Prairie, Minn.; break-away support materials commercially available under the trade designation “BASS” from Stratasy, Inc., Eden Prairie, Minn., and those disclosed in Crump et al., U.S. Pat. No. 5,503,785; Lombardi et al., U.S. Pat. Nos. 6,070,107 and 6,228,923; Priedeman et al., U.S. Pat. No. 6,790,403; and Hopkins et al., U.S. Patent Application Publication No. 2010/0096072.

The composition of ribbon filament 34 may also include additional additives, such as plasticizers, rheology modifiers, inert fillers, colorants, stabilizers, and combinations thereof. Examples of suitable additional plasticizers for use in the support material include dialkyl phthalates, cycloalkyl phthalates, benzyl and aryl phthalates, alkoxy phthalates, alkyl/aryl phosphates, polyglycol esters, adipate esters, citrate esters, esters of glycerin, and combinations thereof. Examples of suitable inert fillers include calcium carbonate, magnesium carbonate, glass spheres, graphite, carbon black, carbon fiber, glass fiber, talc, wollastonite, mica, alumina, silica, kaolin, silicon carbide, composite materials (e.g., spherical and filamentary composite materials), and combinations thereof. In embodiments in which the composition includes additional additives, examples of suitable combined concentrations of the additional additives in the composition range from about 1% by weight to about 10% by weight, with particularly suitable concentrations ranging

from about 1% by weight to about 5% by weight, based on the entire weight of the composition.

Ribbon filament **34** also desirably exhibits physical properties that allow ribbon filament **34** to be used as a consumable material in system **10**. In one embodiment, the composition of ribbon filament **34** is substantially homogenous along its length. Additionally, the composition of ribbon filament **34** desirably exhibits a glass transition temperature that is suitable for use in build chamber **12**. Examples of suitable glass transition temperatures at atmospheric pressure for the composition of ribbon filament **34** include temperatures of about 80° C. or greater. In some embodiments, suitable glass transition temperatures include about 100° C. or greater. In additional embodiments, suitable glass transition temperatures include about 120° C. or greater.

Ribbon filament **34** also desirably exhibits low compressibility such that its axial compression doesn't cause ribbon filament **34** to be seized within a liquefier. Examples of suitable Young's modulus values for the polymeric compositions of ribbon filament **34** include modulus values of about 0.2 gigapascals (GPa) (about 30,000 pounds-per-square inch (psi)) or greater, where the Young's modulus values are measured pursuant to ASTM D638-08. In some embodiments, suitable Young's modulus range from about 1.0 GPa (about 145,000 psi) to about 5.0 GPa (about 725,000 psi). In additional embodiments, suitable Young's modulus values range from about 1.5 GPa (about 200,000 psi) to about 3.0 GPa (about 440,000 psi).

In some embodiments, as discussed below, ribbon filament **34** may be a multi-layer filament. For example, ribbon filament **34** may include a central layer disposed between exterior layers of different materials. This allows ribbon filament **34** to exhibit a variety of physical and aesthetic qualities. In additional embodiments, ribbon filament **34** may exhibit topographical surface patterns at various locations along length **36**. For example, ribbon filament **34** may include topographical surface patterns as disclosed in Batchelder et al., U.S. Patent Application Publication No. 2011/0076495.

FIG. 3 is a sectional view of section 3-3 taken in FIG. 2, illustrating profile **38** of ribbon filament **34**. Profile **38** is an axially asymmetric, cross-sectional profile of ribbon filament **34** at a location along length **36**. In the shown embodiment, ribbon filament **34** has substantially the same profile **38** along length **36**, thereby allowing the entire length **36** to be used during the build operation. Alternatively, one or more portions of length **36** (e.g., the trailing end segment) may be non-usable.

In the shown embodiment, ribbon filament **34** has a cross-sectional width **40** and a cross-sectional thickness **42**. Suitable dimensions for width **40** and thickness **42** desirably allow ribbon filament **34** to mate with a rectangular liquefier of extrusion head **18**, and also desirably provide a cross-sectional aspect ratio that reduces the response time of the extruded material compared to a cylindrical filament in a cylindrical liquefier with the same volumetric flow rate.

Examples of suitable dimensions for width **40** range from about 1.0 millimeter (about 0.04 inches) to about 10.2 millimeters (about 0.40 inches), with particularly suitable widths ranging from about 2.5 millimeters (about 0.10 inches) to about 7.6 millimeters (about 0.30 inches), and with even more particularly suitable widths ranging from about 3.0 millimeters (about 0.12 inches) to about 5.1 millimeters (about 0.20 inches).

Thickness **42** is desirably thick enough to provide a suitable structural integrity for ribbon filament **34**, thereby reducing the risk of fractures or breaks while ribbon filament

34 is retained in supply source **20** or **22** and while being fed through system **10** (e.g., through pathways **30** or **32**). Examples of suitable dimensions for thickness **42** range from about 0.08 millimeters (about 0.003 inches) to about 1.5 millimeters (about 0.06 inches), with particularly suitable thicknesses ranging from about 0.38 millimeters (about 0.015 inches) to about 1.3 millimeters (about 0.05 inches), and with even more particularly suitable thicknesses ranging from about 0.51 millimeters (about 0.02 inches) to about 1.0 millimeters (about 0.04 inches).

As discussed below, the aspect ratio of width **40** to thickness **42**, and a corresponding aspect ratio of the rectangular liquefier, may be selected to effectively remove the core that is associated with a cylindrical filament having a circular cross-section. This allows ribbon filament **34** to be melted and extruded in a rectangular liquefier with a reduced response time.

FIG. 4 is an exploded perspective view of subassembly **44**, which is a suitable subassembly of extrusion head **18** (shown in FIG. 1) for use with ribbon filament **34**. Subassembly **44** includes drive mechanism **46**, liquefier **48**, and thermal block **50**. Drive mechanism **46** is a filament drive mechanism that feeds successive portions of ribbon filament **34** from pathway **30** (shown in FIG. 1) to liquefier **48**. Drive mechanism **46** is desirably in signal communication with controller **28** (shown in FIG. 1), thereby allowing controller **28** to direct the rates at which drive mechanism **46** feeds ribbon filament **34** to liquefier **48**. While shown as a pair of drive wheels, drive mechanism **46** may include a variety of different mechanisms for feeding ribbon filament **34** to liquefier **48**. Examples of suitable filament drive mechanisms for drive mechanism **46** include those disclosed in Batchelder et al., U.S. Patent Application Publication Nos. 2009/0274540 and 2009/0273122.

Liquefier **48** is a non-cylindrical liquefier that includes channel **52** extending between top end **54** and bottom end **56**. Top end **54** and bottom end **56** are opposing ends of liquefier **48** along longitudinal axis **58**. Channel **52** is a rectangular slot in which ribbon filament **34** is received and melted. Accordingly, the inlet of channel **52** at top end **54** desirably has dimensions that allow ribbon filament **34** to slide into channel **52** without undue frictional resistance. Channel **52** also desirably exhibits substantially the same cross-sectional profile along longitudinal axis **58** between top end **54** and bottom end **56**. In alternative embodiments, however, the cross-sectional profile of channel **52** may taper down to a smaller cross-sectional area at bottom end **56**.

Liquefier **48** also includes extrusion tip **60**, which is a small-diameter tip that is located at a bottom end **56** and is configured to extrude the molten material of ribbon filament **34** with a desired road width. Examples of suitable inner tip diameters for extrusion tip **60** range from about 125 micrometers (about 0.005 inches) to about 510 micrometers (about 0.020 inches).

Thermal block **50** is a heat transfer component that extends around at least a portion of liquefier **48** and is configured to conduct heat to liquefier **48** and the received ribbon filament **34**. Examples of suitable heat transfer components for thermal block **50** include those disclosed in Swanson et al., U.S. Pat. No. 6,004,124; Comb, U.S. Pat. No. 6,547,995; LaBossiere et al., U.S. Publication No. 2007/0228590; and Batchelder et al., U.S. Patent Application Publication No. 2009/0273122. In alternative embodiments, thermal block **50** may be replaced with a variety of different heat transfer components that generate and/or

transfer heat to liquefier 48, thereby forming a thermal gradient within liquefier 48 along longitudinal axis 58.

During a build operation in system 10 (shown in FIG. 1), ribbon filament 34 is engaged with drive mechanism 46 and loaded into channel 52 of liquefier 48. Controller 28 then directs drive mechanism 46 drive successive portions of ribbon filament 34 through liquefier 48. As ribbon filament 34 passes through liquefier 48, the thermal gradient generated by thermal block 50 melts the material of ribbon filament 34 within liquefier 48. The upstream, unmelted portion of ribbon filament 34 being driven by drive mechanism 46 functions as a piston with a viscosity pump acting on the molten material between the unmelted portion and the walls of liquefier 48, thereby extruding the molten material out of extrusion tip 60. The extruded material may then be deposited as roads to form 3D model 24 in a layer-by-layer manner.

As discussed above, ribbon filament 34 is capable of being melted and extruded from liquefier 48 with reduced response times compared to cylindrical filaments melted and extruded from cylindrical liquefiers with the same volumetric flow rates. For cylindrical liquefiers, the response is dominated by RC-like lumped parameters. As such, the response time for cylindrical liquefiers refers to the 1/e time, which is the time for the flow rate to change from 0% to within about 63% of a new steady state value. In comparison, for non-cylindrical liquefiers such as liquefier 48, the response is dominated by transmission-line parameters. As such, the response time for non-cylindrical liquefiers such as liquefier 48 refers to the time between about the 10% and about the 90% flow rate changes.

For example, the response time of subassembly 44 is the time required for the flow rate of the molten material at extrusion tip 60 to respond to a change in the drive pressure that drive mechanism 46 applies to ribbon filament 34 (due to commands from controller 28). Low response times are helpful for improving the aesthetic and structural qualities of the resulting 3D model, particularly when building 3D models containing fine features. In particular, low response times are necessary for building 3D models at high speeds, since it determines the degree that a gantry (e.g., gantry 16) can slow down going into a corner and subsequently speed up as it leaves the corner.

The “volumetric flow rate” refers to the thermally-limited, maximum volumetric flow rate through a liquefier, which is the maximum volumetric flow rate of a material that a liquefier can liquefy to an extrudable state and then extrude. For a cylindrical liquefier, the thermally-limited, maximum volumetric flow rate $Q_{max,c}$ may be determined pursuant to Equation 1:

$$Q_{max,c} = 2\pi\kappa L_{p,c}$$

where κ is the thermal diffusivity of the material of a cylindrical filament, and $L_{p,c}$ is the length of the cylindrical liquefier containing molten material. Thus, based solely on this characteristic, the volumetric flow rate $Q_{max,c}$ can be increased merely by increasing the length of the cylindrical liquefier containing molten material.

However, in a cylindrical liquefier having a particular diameter, increasing the flow rate $Q_{max,c}$ also increases the flow resistance, which correspondingly increases the response time. The response time may be represented by a lumped, pressure change time constant τ_c , which is the product of the flow resistance and the flow capacitance of the cylindrical liquefier and filament material. The flow resistance FR_c for the cylindrical liquefier in pressure per (volume per second) may be determined pursuant to Equation 2:

$$FR_c = \frac{128\eta L_{p,c}}{\pi d_c^4}$$

where η is the dynamic viscosity of the material of the cylindrical filament, and d_c is the inner diameter of the cylindrical liquefier. The flow capacitance FC_c for the cylindrical liquefier may be determined pursuant to Equation 3:

$$FC_c = \frac{\pi d_c^2 L_{p,c}}{4B}$$

where B is the bulk modulus of the filament material (i.e., the material’s resistance to uniform compression).

By combining the flow resistance and the flow capacitance of the cylindrical liquefier, the response time for the cylindrical liquefier, based on a lumped, pressure change time constant τ_c , may be determined pursuant to Equation 4:

$$\tau_c = \frac{32\eta L_{p,c}^2}{Bd_c^2}$$

Combining Equations 1 and 4 illustrates the proportional relationship between the time constant τ_c and the volumetric flow rate $Q_{max,c}$ for the cylindrical liquefier, which is shown in Equation 5:

$$\tau_c = \frac{8\eta Q_{max,c}^2}{\pi^2 \kappa^2 B d_c^2}$$

As shown in Equation 5, increasing the volumetric flow rate of material correspondingly increases the response time, thereby undesirably increasing the time required for the pressure of the molten material at an extrusion tip to respond to a change in drive pressure on the cylindrical filament.

One potential technique for reducing the response time is to increase the diameters of the cylindrical filament and liquefier. However, cylindrical filaments having diameters greater than about 2.5 millimeters (about 0.1 inches) become difficult to handle and manage in an extrusion-based digital manufacturing system. As such, for a given volume in a cylindrical liquefier, an increase in the volumetric flow rate of the material undesirably increases the response time, and vice versa. These competing factors effectively limit the achievable response times and volumetric flow rates for cylindrical liquefiers.

FIGS. 5A and 5B are sectional views of sections 5A-5A and 5B-5B taken in FIG. 4, respectively, which illustrate ribbon filament 34 being melted in liquefier 48. As shown in FIG. 5A, thermal block 50 is configured to extend around and heat a portion of the length of liquefier 48 (referred to as heated length 62). Examples of suitable heated lengths 62 for liquefier 48 range from about 13 millimeters (about 0.5 inch) to about 130 millimeters (about 5.0 inches), with particularly suitable lengths 88 ranging from about 25 millimeters (about 1.0 inch) to about 51 millimeters (about 2.0 inches).

As ribbon filament 34 is driven into channel 52 of liquefier 48, successive portions of ribbon filament 34 are melted to at least an extrudable state to form melt pool 64 of the molten material in channel 52. As shown, melt pool 64

extends along axis 58 between bottom end 56 and meniscus 66. Accordingly, the length of liquefier 48 containing melt pool 64 along axis 58 (referred to as length 68) extends between bottom end 56 and meniscus 66. The location of meniscus 66 within liquefier 48 may vary depending on factors such as the thermal profile along liquefier 48, the dimensions of liquefier 48, the material of ribbon filament 34, the drive rate of ribbon filament 34, and the like. However, during steady state extrusion, meniscus 66 may be maintained at a substantially constant level such that length 68 of melt pool 64 is typically less than heated length 62.

As respectively shown in FIGS. 5A and 5B, channel 52 of liquefier 48 has a cross-sectional width (referred to as width 70) and a cross-sectional thickness (referred to as thickness 72), where width 70 is greater than thickness 72. This is further illustrated in FIG. 5C, which shows an inlet cross-sectional profile of channel 52 (referred to as channel profile 74). Suitable dimensions for width 70 and thickness 72 desirably allow ribbon filament 34 to mate with channel 52, as discussed above. As also discussed above, channel profile 74 also desirably exhibits substantially the same dimensions along heated length 62 of liquefier 48 (shown in FIGS. 5A and 5B). In alternative embodiments, however, channel profile 74 may taper down to a smaller cross-sectional area adjacent to bottom end 56 of liquefier 48 (shown in FIGS. 4, 5A, and 5B). In additional alternative embodiments, channel profile 74 may taper up to a larger cross-sectional area to provide stability to the meniscus position.

Suitable dimensions for width 70 and thickness 72 at channel profile 74 include widths that allow ribbon filament 34 to mate with channel 52 without undue friction. Examples of suitable dimensions for width 70 range from about 1.0 millimeter (about 0.04 inches) to about 12.7 millimeters (about 0.50 inches), with particularly suitable widths ranging from about 3.0 millimeters (about 0.12 inches) to about 10.1 millimeters (about 0.40 inches), and with even more particularly suitable widths ranging from about 3.8 millimeters (about 0.15 inches) to about 6.4 millimeters (about 0.25 inches).

Examples of suitable dimensions for thickness 72 range from about 0.25 millimeters (about 0.01 inches) to about 2.5 millimeters (about 0.10 inches), with particularly suitable thicknesses ranging from about 0.51 millimeters (about 0.02 inches) to about 2.0 millimeters (about 0.08 inches), and with even more particularly suitable thicknesses ranging from about 0.76 millimeters (about 0.03 inches) to about 1.8 millimeters (about 0.07 inches).

While not wishing to be bound by theory, it is believed that the aspect ratio of channel profile 74 effectively removes the core that is associated with a cylindrical filament having a circular cross-section. This allows liquefier 48 to achieve reduced response times compared to a cylindrical liquefier having the same wetted channel volume (e.g., the volume of channel 52, which is the area of channel profile 74 taken along length 68, shown in FIGS. 5A and 5B). Ignoring the heat diffusing from the edges of ribbon filament 34, assuming that width 70 is large compared to thickness 72, the time-dependant temperature profile of ribbon filament 34 may be determined pursuant to Equation 6:

$$\text{Temp}(x, t) = \text{Temp}_a + (\text{Temp}_f - \text{Temp}_a)$$

$$\sum_{n=0}^{\infty} (-1)^n \left\{ \text{erfc} \left(\frac{(2n+1)T_f - 2x}{4\sqrt{kt}} \right) + \text{erfc} \left(\frac{(2n+1)T_f + 2x}{4\sqrt{kt}} \right) \right\}$$

where Temp_a is an initial temperature of ribbon filament 34 prior to being heated in liquefier 48, Temp_f is the temperature of liquefier 48, T_f is the thickness of ribbon filament 34 (i.e., thickness 42), where $-T_f < 2x < T_f$, and where erfc is the complimentary error function as shown in Equation 7:

$$\text{erfc}(x) = \frac{2}{\pi} \int_x^{\infty} \exp(-t^2) dt$$

The complimentary error function has an asymptotic expansion as shown in Equation 8:

$$\text{erfc}(x) = \frac{e^{-x^2}}{x\sqrt{\pi}} \left[1 + \sum_{n=0}^{\infty} (-1)^n \frac{1, 3, 5, \dots, (2n-1)}{(2x^2)^n} \right]$$

From Equation 8, the characteristic lowest-order time constant can be extracted, which may be represented by Equation 9:

$$\tau_f = \frac{T_f^2}{16\kappa}$$

Incorporating the first one-hundred terms of the asymptotic expansion in Equation 8, using a thermal diffusivity κ of 8.13 millimeters/second² (0.320 inches/second²) (a suitable value for ABS materials), a thickness T_f of ribbon filament 34 (i.e., thickness 42) of 0.76 millimeters (0.03 inches), an initial temperature Temp_a of 80° C., and a wall temperature Temp_f of liquefier 48 of 320° C., a reasonable time for the average temperature to move half-way to the asymptotic temperature, as represented by the lowest-order time constant τ_f , is about 0.24 seconds. Accordingly, a reasonable estimate for the time required to heat ribbon filament 34 is about four times the lowest-order time constant τ_f (i.e., $4\tau_f$). Thus, this process produces a volume of the molten material in $4\tau_f$ seconds as determined pursuant to Equation 10:

$$Q(4\tau_f) = (W_r)(T_r)(L_{p,r})$$

where W_r is the width of channel 52 (i.e., width 70), T_r is the thickness of channel 52 (i.e., thickness 72), and $L_{p,r}$ is the length of channel 52 containing molten material (i.e., length 68).

Accordingly, for a rectangular liquefier (e.g., liquefier 48), the thermally-limited, volumetric flow rate $Q_{max,r}$ may be determined pursuant to Equation 11:

$$Q_{max,r} = 4\kappa L_{p,r} \frac{W_r}{T_r}$$

As shown in Equation 11, the thermally-limited, maximum volumetric flow rate $Q_{max,r}$ is governed by the length of liquefier 48 containing the molten material (i.e., length 68). Thus, the operative length is the heated length of ribbon filament 34 rather than the heated length of the liquefier (e.g., heated length 62).

As discussed above for the cylindrical liquefier, the response time for a rectangular liquefier (e.g., liquefier 48) is also the product of the flow resistance and the flow capacitance of the rectangular liquefier and ribbon filament

13

material. The flow resistance FR_r , for the rectangular liquefier may be determined pursuant to Equation 12:

$$FR_r = \frac{12\eta L_{p,r}}{W_r T_r^3}$$

The flow capacitance FC_r , for the rectangular liquefier may be determined pursuant to Equation 13:

$$FC_r = \frac{W_r T_r L_{p,r}}{B}$$

By combining the flow resistance and the flow capacitance of the rectangular liquefier, the response time τ_r , for the rectangular liquefier may be determined pursuant to Equation 14:

$$\tau_r = \frac{12\eta L_{p,r}^2}{BT_r^2}$$

Combining Equations 11 and 14 illustrates the proportional relationship between the response time τ_r and the volumetric flow rate $Q_{max,r}$ for the rectangular liquefier, which is shown in Equation 15:

$$\tau_r = \frac{3\eta Q_{max,r}^2}{4\kappa^2 BW_r^2}$$

A comparison of Equations 5 and 15 shows that, for the same thermally-limited, maximum volumetric flow rates (i.e., $Q_{max,c}=Q_{max,r}$), when width **40** of ribbon filament **34** is greater than thickness **42** of ribbon filament **34**, the response time for controlling the extrusion of ribbon filament **34** in liquefier **48** is less than the response time for a cylindrical filament in a cylindrical liquefier. For the same thermally-limited, maximum volumetric flow rates (i.e., $Q_{max,c}=Q_{max,r}$), the aspect ratio of profile **38** of ribbon filament **34** and channel profile **74** of channel **52** desirably provides a response time that is at least 1.5 times faster than a response time achievable with a cylindrical liquefier having a circular cross-sectional profile. More desirably, the response time is at least two times faster, and even more desirably is at least three times faster. Accordingly, examples of suitable aspect ratios of width **40** to thickness **42** include aspect ratios of about 2:1 or greater, with particularly suitable aspect ratios ranging from about 2.5:1 to about 20:1, with even more particularly suitable aspect ratios ranging from about 3:1 to about 10:1, and with even more particularly suitable aspect ratios ranging from about 3:1 to about 8:1.

The comparison of Equations 5 and 15 may be visualized by superimposing multiple cylindrical liquefiers in an array to form a slot comparable to channel profile **74** of channel **52**, as shown in FIG. 6. This results in the same cross-sectional areas for the cylindrical liquefiers (referred to as cylindrical liquefiers **76**) and channel profile **74**, ignoring the interstitial spaces between cylindrical liquefiers **76**. Accordingly, in this example, the diameter of each cylindrical liquefier **76** is the same as thickness **72**. It is also assumed that the lengths of each cylindrical liquefier **76** containing molten material is the same as length **68** of melt pool **64**. As

14

such the combined wetted volumes of cylindrical liquefiers **76** is the same as the wetted volume of liquefier **48**.

The ratio of the response time of the cylindrical liquefier to the response time of liquefier **48** τ_c/τ_r is shown in Equation 16:

$$\frac{\tau_r}{\tau_c} = \frac{3\pi^2 d_c^2}{32W_r^2} = 0.93 \frac{d_c^2}{W_r^2}$$

Thus, as shown in Equation 16, for the same thermally-limited, maximum volumetric flow rates (i.e., $Q_{max,c}=Q_{max,r}$), the ratio of the response time of the cylindrical liquefier to the response time of liquefier **48** is proportional to the diameter of the cylindrical liquefier squared over thickness **72** of channel **52** squared. For example, a cylindrical liquefier having a diameter of 1.78 millimeters (0.070 inches) and liquefier **48** having width **70** of 3.05 millimeters (0.120 inches) and thickness **72** of 0.813 millimeters (0.032 inches) (i.e., an aspect ratio of about 4:1) have substantially the same cross-sectional areas. Thus, for these cross-sectional areas, and the same melt pool lengths (e.g., length **68**), and $Q_{max,c}=Q_{max,r}$ pursuant to Equation 16, the response time ratio $\tau_r/\tau_c=0.32$. In other words, the response time for liquefier **48** with ribbon filament **34** is about three times faster than the response time achievable with the cylindrical liquefier and the cylindrical filament.

In another example, a cylindrical liquefier having a diameter of 1.78 millimeters (0.070 inches) and liquefier **48** having width **70** of 4.19 millimeters (0.165 inches) and thickness **72** of 0.584 millimeters (0.023 inches) (i.e., an aspect ratio of about 7:1) also have substantially the same cross-sectional areas. Thus, for these cross-sectional areas, and the same molten lengths, and $Q_{max,c}=Q_{max,r}$ pursuant to Equation 16, the response time ratio $\tau_r/\tau_c=0.167$. In other words, in this example, the response time for liquefier **48** and ribbon filament **34** is about six times faster than the response time achievable with the cylindrical liquefier and the cylindrical filament. This illustrates that as the aspect ratios of ribbon filament **34** and channel **52** increase, the response times also increase.

While again not wishing to be bound by theory, it is believed that this reduction in response time is due to the fact that the array of cylindrical liquefiers contain additional wall sections that effectively form webs in the cross-sectional area of rectangular liquefier **48**, thereby increasing frictional resistance. This increased frictional resistance is not found in channel profile **74**. As such, for a given thermally-limited, maximum volumetric flow rate, liquefier **48** is capable of receiving, melting, and extruding ribbon filament **34** with a reduced response time compared to a cylindrical liquefier and a cylindrical filament.

The above-discussed embodiments were directed to a non-cylindrical filament having a rectangular cross-sectional profile (i.e., ribbon filament **34**), and a non-cylindrical liquefier having a corresponding rectangular channel (i.e., liquefier **48**). The cross-sectional profiles of these embodiments may be properly characterized by cross-sectional aspect ratios of width to thickness (e.g., width **40** to thickness **42** of ribbon filament **34**, and width **70** to thickness **72** of channel **52**). However, many non-cylindrical filaments and liquefiers may have cross-sectional profiles that cannot be properly characterized by cross-sectional aspect ratios of width to thickness. As such, an alternative manner for properly characterizing the cross-sectional profiles of non-

15

cylindrical filaments and liquefiers may be made with a hydraulic diameter D_h , as represented by Equation 17:

$$D_h = \frac{4A_e}{U}$$

where A_e is the area of the cross-sectional profile at the entrance of the liquefier channel, and U is the wetted perimeter of the liquefier channel.

For a cylindrical liquefier, Equation 17 reduces to $D_h = D_c$. For a rectangular liquefier such as liquefier **48**, where channel **52** is substantially filled with the molten material, $A_e = W_r T_r$, and $U = 2(W_r + T_r)$, and the hydraulic diameter D_h may be represented by Equation 18:

$$D_h = \frac{2W_r T_r}{W_r + T_r}$$

Accordingly, suitable cross-sectional profiles for non-cylindrical filaments and liquefiers of the present disclosure desirably have hydraulic diameters D_h that are represented by Equation 19:

$$D_h < P_1 \sqrt{A_e}$$

where P_1 is a percentage value such that D_h is less than percentage P_1 of $\sqrt{A_e}$. Examples of suitable values for percentage P_1 include about 0.95 (i.e., $D_h < 0.95\sqrt{A_e}$), with particularly suitable values percentage P_1 including about 0.90 (i.e., $D_h < 0.90\sqrt{A_e}$), and with even more particularly suitable values percentage P_1 including about 0.87 (i.e., $D_h < 0.87\sqrt{A_e}$).

Equation 19 illustrates suitable upper limits for the hydraulic diameters D_h of the non-cylindrical filaments and liquefiers of the present disclosure. Accordingly, the suitable cross-sectional profiles for non-cylindrical filaments and liquefiers of the present disclosure also desirably have hydraulic diameters D_h that are represented by Equation 20:

$$D_h > P_2 \sqrt{A_e}$$

where P_2 is a percentage value such that D_h is greater than percentage P_2 of $\sqrt{A_e}$. Examples of suitable values for percentage P_2 include about 0.40 (i.e., $D_h > 0.40\sqrt{A_e}$), with particularly suitable values percentage P_2 including about 0.55 (i.e., $D_h > 0.55\sqrt{A_e}$), and with even more particularly suitable values percentage P_2 including about 0.70 (i.e., $D_h > 0.70\sqrt{A_e}$). Thus, the hydraulic diameters D_h of the non-cylindrical filaments and liquefiers of the present disclosure desirably meet the criteria of Equation 19, desirably meet the criteria of Equation 20, and even more desirably meet the criteria of Equation 19 and of Equation 20. These values correspond to the above-discussed suitable cross-sectional aspect ratios for a rectangular liquefier such as liquefier **48**. In comparison, cylindrical filaments and liquefiers require P_1 and P_2 to each be about 2.25.

FIGS. 7-11 illustrate suitable embodiments for manufacturing non-cylindrical filaments, such as ribbon filament **34** (shown in FIGS. 2-4), prior to use in extrusion-based digital manufacturing systems (e.g., system **10**, shown in FIG. 1). FIG. 7 is a flow diagram of method **78**, which is an example of a suitable method for manufacturing non-cylindrical filaments, such as ribbon filament **34**. As shown, method **78** includes steps **80-88**, and initially involves supplying a feed material to a sheet extrusion system (step **80**). The feed

16

material may be supplied to the production system in a variety of different media, such as pellets, rods, powders, particulates, blocks, ingots, and the like. Suitable compositions for the feed materials include those discussed above for the modeling and support materials of ribbon filament **34**.

Upon being supplied to the sheet extrusion system, the feed material may be melted and extruded to produce an extruded sheet of the feed material (step **82**). As discussed below, the extruded sheet may subsequently be used and separated into a plurality of individual ribbon filaments, where the thickness of the extruded sheet in a solid state desirably matches the thickness of each of the ribbon filaments. After being extruded, the extruded sheet is desirably cooled to at least partially solidify the extruded sheet (step **84**). In some embodiments, as discussed below, the sheet may also be laminated with additional sheets of different materials to form a multi-layer sheet.

At this point in the process, the sheet may be stored (e.g., wound up on a take-up spool) for subsequent separation or directly fed to a sheet cutter, such as in a continuous process. At the sheet cutter, the sheet may be cut longitudinally into the plurality of ribbon filaments, where the cross-sectional profile of at least one of the ribbon filaments is desirably configured to mate with a non-cylindrical liquefier (e.g., liquefier **48**), as discussed above (step **86**). More desirably, each of the ribbon filaments cut from the extruded sheet are configured to mate with a non-cylindrical liquefier (e.g., liquefier **48**).

After being cut, the ribbon filaments may then be loaded onto supply assemblies (step **88**). In one embodiment, the loading process for the plurality of ribbon filaments may be performed in a substantially parallel manner, where after being cut from the extruded sheet, the ribbon filaments are fed onto multiple take-up spools in a substantially continuous manner. The supply assemblies may then be used in one or more extrusion-based digital manufacturing systems (e.g., system **10**) for building 3D models and support structures.

FIG. 8 is a perspective view of sheet **90**, which is an example of an extruded sheet that may be produced pursuant to steps **80**, **82**, and **84** of method **78** (shown in FIG. 7). As shown in FIG. 8, sheet **90** may be cut into a plurality of ribbon filaments **92**, where each ribbon filament **92** desirably corresponds to ribbon filament **34** (shown in FIGS. 2-4). The number of ribbon filaments **92** that may be produced from a single sheet **90** may vary depending on the width of sheet **90** (referred to as sheet width **94**). Examples of suitable numbers of ribbon filaments **92** that may be extruded from a single sheet **90** range from about five to about one hundred, with particularly suitable numbers ranging from about ten to about fifty.

Sheet width **94** of sheet **90** desirably minimizes the amount of wasted material. As such, cut ribbon filaments **92** desirably extend across the entire sheet width **94**. In alternative embodiments, however, one or more portions along the sheet width **94** of sheet **90** may be discarded or recycled. For example, the lateral edge portions of the width of sheet **90** may be discarded or recycled, as desired. Examples of suitable dimensions for sheet width **94** range from about 0.3 meters (about 1.0 foot) to about 1.2 meters (about 4.0 feet) with particularly suitable widths ranging from about 0.46 meters (about 1.5 feet) to about 0.91 meters (about 3.0 feet).

Additionally, sheet **90**, in a solidified state, desirably has a sheet thickness (referred to as sheet thickness **96**) that is substantially the same as the desired thicknesses of ribbon filaments **92** (e.g., thickness **42** of ribbon filament **34**). Examples of suitable dimensions for sheet thickness **96** range from about 0.08 millimeters (about 0.003 inches) to

about 1.5 millimeters (about 0.06 inches), with particularly suitable thicknesses ranging from about 0.38 millimeters (about 0.015 inches) to about 1.3 millimeters (about 0.05 inches), and with even more particularly suitable thicknesses ranging from about 0.51 millimeters (about 0.02 inches) to about 1.0 millimeters (about 0.04 inches).

After being extruded and at least partially solidified, sheet **90** may then be cut into ribbon filaments **92**, pursuant to step **86** of method **78**. This is illustrated in FIG. **8** with a cut line **98** located between each ribbon filament **92**. After being cut from extrusion sheet **90**, each ribbon filament **92** may then be loaded onto a supply assembly (e.g., a spool), pursuant to step **88** of method **78**. This process allows multiple ribbon filaments **92** to be fabricated from a single extruded sheet **90** without requiring additional resizing steps to attain the desired thicknesses for ribbon filaments **92**. This correspondingly allows high production rates to be achieved.

FIG. **9** is a schematic illustration of sheet extrusion system **100**, which is an example of a suitable system for producing extruded sheets (e.g., sheet **90**, shown in FIG. **8**) pursuant to method **78** (shown in FIG. **7**). As shown, system **100** includes extrusion assembly **102**, cooling drums **104** and **106**, pulleys **108** and **110**, and take-up spool **112**. Extrusion assembly **102** is configured to receive and extrude a feed material of the desired modeling and/or support material (shown as media **114**), to produce sheet **90**. Extrusion assembly **102** includes hopper **116**, thermal sleeve **118**, drive screw **120** and extrusion outlet **122**. While shown in a vertical orientation, extrusion assembly **102** (and system **100**) may alternatively be positioned in different orientations (e.g., a horizontal orientation). During operation, drive screw **120** feeds successive portions of media **114** from hopper **116** to an extrusion shaft defined by thermal sleeve **118** (referred to as extrusion shaft **124**). Thermal sleeve **118** transfers thermal energy to media **114** as media **114** is fed into extrusion shaft **122**, thereby melting and extruding media **114** out of extrusion outlet **122** to produce sheet **90**.

Sheet **90** may then engage cooling drums **104** and **106** to define the thickness of sheet **90** (i.e., sheet thickness **96**). Cooling drums **104** and **106** are cylindrical drums that are desirably maintained at reduced temperatures to cool sheet **90** as sheet **90** engages with cooling drums **104** and **106** at nip **126**. The reduced temperatures for cooling drums **104** and **106** may vary depending on factors such as the line speed of sheet **90**, the composition and dimensions of sheet **90**, and the like. Examples of suitable temperatures for cooling drums **104** and **106** range from about 40° C. to about 60° C. This allows sheet **90** to at least partially solidify to a solid state while maintaining sheet thickness **96** after passing through nip **126**.

Accordingly, cooling drum **104** is desirably offset from cooling drum **106** at nip **126** at a distance that sets sheet thickness **96** for sheet **90**. As a result, the thicknesses of successive portions of sheet **90** may match the desired thickness of each ribbon filament **92** that will be cut from sheet **90**. This allows each ribbon filament **92** to subsequently mate with a corresponding non-cylindrical liquefier (e.g., liquefier **48**) to attain reduced response times, as discussed above. In one embodiment, system **100** may also include a sensor assembly (not shown) configured to detect and measure the sheet thickness of sheet **90** in real time, and to adjust one or more processing parameters to achieve the desired sheet thickness (e.g., adjusting line speeds, nip dimensions, and the like).

In one embodiment, topographical surface patterns may be formed in sheet **90** to provide ribbon filaments **92** having topographical surface patterns as disclosed in Batchelder et

al., U.S. Patent Application Publication No. 2011/0076495. In this embodiment, one or both of cooling drums **104** and **106** may include a textured outer surface configured to form the topographical surface patterns in sheet **90** when sheet **90**. This is beneficial for forming the topographical surface patterns prior to sheet **90** fully solidifying. Alternatively, the patterns in sheet **90** may be formed with the use of additional rollers having textured surfaces, where the additional rollers may be located upstream or downstream from cooling drums **104** and **106**.

In an additional embodiment, system **100** may include one or more coating units (not shown) to apply a coating on one or both major surfaces of sheet **90**. For example, system **100** may include a corona discharge unit (not shown) configured to deposit thin coatings of a material on either or both major surfaces of sheet **90**. This allows a variety of coating materials to be deposited on sheet **90**, such as low-surface energy materials. Low-surface energy materials may be beneficial for reducing frictional resistance as ribbon filaments **92** are driven into rectangular liquefiers (e.g., liquefier **48**) of extrusion-based digital manufacturing systems (e.g., system **10**).

Sheet **90** may then wind around pulleys **108** and **110**, and be wound up on take-up spool **112**, where one or more of cooling drums **104** and **106**, pulleys **108** and **110**, and take-up spool **112** may be motor drive to apply a suitable line speed for forming sheet **90**. Examples of suitable line speeds for forming sheet **90** range from about 1 meter/minute to about 20 meters/minute, with particularly suitable line speeds ranging from about 5 meters/minute to about 15 meters/minute. In alternative embodiments, additional numbers of pulleys may be used to direct sheet **90** to take-up spool **112**. After a suitable length of sheet **90** is wound up on take-up spool **112**, sheet **90** may be separated and take-up spool **112** may be stored or set up for subsequent processing to cut sheet **90** into separate ribbon filaments **92**, as discussed below. In an alternative embodiment, sheet **90** may be fed directly to a cutting unit to cut sheet **90** into separate ribbon filaments **92**. In this embodiment, take-up spool **112** may be omitted and sheet **90** may be cut into ribbon filaments **92** in a continuous process with the extrusion and forming of successive portions of sheet **90**.

FIG. **10** is a schematic illustration of filament-production system **128**, which is a suitable system for forming ribbon filaments **92** from sheet **90**. System **128** includes cutting roller **130**, backing roller **132**, idler pulleys **134**, and take-up spools **136a-136d**. As shown, sheet **90** may be supplied to the nip intersection of cutting roller **130** and backing roller **132** from a take-up spool (e.g., take-up spool **112**) or as a direct feed from system **100** for a continuous process.

Cutting roller **130** is a first roller that includes a cylindrical surface having a plurality of parallel thin blades configured to cut successive portions of sheet **90** into separate ribbon filaments (referred to as ribbon filaments **92a-92d**). Accordingly, the parallel blades of cutting roller **130** are desirably separated by gaps that account for the widths of ribbon filaments **92** (e.g., width **40** of ribbon filament **34**, shown in FIG. **3**). Cutting roller **130** is also desirably motor driven to pull sheet **90** between cutting roller **130** and backing roller **132** during the cutting operation. Backing roller **132** is a second roller that is spaced apart from cutting roller **130** by a suitable distance to allow sheet **90** to pass between cutting roller **130** and backing roller **132** and engage with the bladed surface of cutting roller **130**.

After being cut from sheet **90**, each ribbon filament **92** (e.g., ribbon filaments **92a-92d**) is desirably fed to a separate spool of take-up spools **136a-136d**. Take-up spool **136a-**

136d are examples of suitable supply assemblies for supply spool 20 and/or supply spool 22 (shown in FIG. 1). Ribbon filaments 92a-92d may be directed to the respective take-up spools 136a-136d with idler pulleys 134. As shown, idler pulleys 134 are positioned to allow ribbon filaments 92a-92d to exit backing roller 132 at different radial locations. This reduces the risk of ribbon filaments 92a-92d from becoming entangled while being loaded to take-up spools 136a-136d.

Each of take-up spools 136a-136d may also be motor driven to respectively wind up ribbon filaments 92a-92d as they are cut from sheet 90. While system 128 is illustrated with four ribbon filaments 92 and four take-up spools 136, cutting roller 130 may cut sheet 90 into any suitable number of ribbon filaments 92, based on the widths of sheet 90 and ribbon filaments 92. The cut ribbon filament 92 may then be loaded onto individual take-up spools 136 in a substantially parallel manner.

While system 128 is shown with a single cutting roller 130/backing roller 132 pair, in alternative embodiments, system 128 may include multiple pairs of cutting rollers/backing rollers. For example, system 128 may include an initial pair of cutting roller 130 and backing roller 132, which may cut sheet 90 into multiple segments, where each segment has a width that includes multiple ribbon filaments 92. Each cut segment may then pass through an additional pair of cutting roller 130 and backing roller 132, which may cut the given segment into the separate ribbon filaments 92. The separate ribbon filaments 92 may then be loaded onto separate take-up spools 136, as discussed above. Thus, sheet 90 may be cut into ribbon filaments 92 during a single cutting step or in multiple successive cutting steps.

Sheet extrusion system 100 and filament-production system 128 are each desirably contained within a housing (not shown) to achieve a dry environment. For example, systems 100 and 128 may each include a dry air circulator and/or desiccant packages to maintain the low moisture content. Furthermore, take-up spools 112 and 136 may each also include desiccant packages to keep the received sheet 90/ribbon filament 92 dry during storage and subsequent use. Suitable techniques for maintaining dry environments in systems 100 and 128, and in take-up spools 112 and 136 include those disclosed in Swanson et al., U.S. Pat. No. 6,923,634; Comb et al., U.S. Pat. No. 7,122,246; and Taatjes et al., U.S. Patent Application Publication Nos. 2010/0096489 and 2010/0096485.

FIGS. 11-13 are alternative sectional views of section 3-3 taken in FIG. 2, which illustrate multi-layer ribbon filaments of the present disclosure. As shown in FIG. 11, ribbon filament 200 has a cross-sectional profile similar to that of ribbon filament 34 (shown in FIG. 2). In this embodiment, however, ribbon filament 200 includes base portion 202 and layer 204, where base portion 202 includes top surface 206 and bottom surface 208, and where layer 202 is formed on top surface 206. Suitable dimensions for ribbon filament 200 include those discussed above for ribbon filament 34. Accordingly, examples of suitable widths for ribbon filament 200 (referred to as width 210) include those discussed above for width 40 of ribbon filament 34. Examples of suitable combined thicknesses of base portion 202 and layer 204 (referred to as thickness 212) include those discussed above for thickness 42 of ribbon filament 34.

Suitable materials for base portion 202 include the modeling and support materials discussed above for ribbon filament 34. Layer 204, however, may include different materials from base portion 202 that may assist in the build operation in system 10 (shown in FIG. 1). For example, many compositions for water-soluble support materials are

relatively brittle, which can result in filament fracturing while being fed through an extrusion-based digital manufacturing system (e.g., system 10). To reduce the brittleness, layer 204 may be formed on top surface 206 as a thin coating from a non-brittle material that is at least partially soluble in water. This allows ribbon filament 200 to be fed through system 10 without fracturing or breaking, thereby increasing reliability in system 10. Relative to the bulk material of base portion 202, the thin coating of layer 204 provides a small amount of the non-brittle material. As such, even if the non-brittle material has a low solubility in water, the overall composition of support structure 26 has a water solubility that is close to that of the bulk material used to form base portion 202, thereby allowing the material of ribbon filament 200 to still function as a suitable water-soluble support material.

FIGS. 12 and 13 illustrate ribbon filaments 300 and 400, which are alternatives to ribbon filament 200, and where the reference labels are increased by "100" and "200" respectively. As shown in FIG. 12, ribbon filament 300 also includes layer 314 formed on bottom surface 308, thereby locating base portion 302 between layers 304 and 314. As shown in FIG. 12, ribbon filament 400 also includes layer 416 disposed between top surface 406 and layer 404, and layer 418 disposed between bottom surface 408 and layer 414. Accordingly, ribbon filaments of the present disclosure may include multiple layers, where each of the layers may include the same or different materials depending on the desired layer properties and on the processes used to form the given layers.

Ribbon filaments 200, 300, and 400 may each be formed generally in the same manner as discussed above for ribbon filaments 92, which may initially involve extruding a base sheet (e.g., sheet 90) with system 100, where the base sheet desirably has the same sheet thickness as the thickness respective base portion (e.g., base portions 202, 302, and 402) (shown in FIG. 9). One or more layers may then be formed on the base sheet surface(s) using a variety of coating techniques. The layer formation process is desirably performed prior to cutting the base sheet into multiple ribbon filaments (e.g., with system 128).

In one embodiment, each layer may be formed by initially forming an additional extruded sheet having a sheet thickness corresponding to the thickness of the given layer. The additional extruded sheet(s) may then be laminated on the base sheet and hot pressed between rollers to secure the layers to the base portion. In this embodiment, layers 416 and 418 of ribbon filament 400 may be used as tie layers to receptively secure layers 404 and 414 to base portion 402. The lamination process may be performed before the base sheet is wound up on a take-up spool (e.g., take-up spool 112), or, alternatively, the base sheet may be wound up on a take-up spool and subsequently unwound for the lamination process.

In an alternative embodiment, each layer may be formed by depositing or otherwise applying a coating onto the base sheet surface(s). For example, each coating may be deposited with a corona discharge unit, as discussed above. Alternatively, each coating may be formed with one or more conventional coating processes, such as knife coating processes and roller coating process.

In an additional alternative embodiment, each layer may be formed by co-extruding sheets of each layer along with the base sheet. This eliminates the use of a separate lamination or coating step to form the layer(s) and allows the dimensions of the multi-layer sheet to be defined with system 100 (e.g., at nip 126).

After the lamination and/or coating process is completed, the multi-layer sheet may then be cut into separate ribbon filaments (e.g., ribbon filaments **200**, **300**, and **400**) with system **128**. The resulting thicknesses of each layer may vary depending on the desired characteristics of the given layer and on the lamination or coating process used. Examples of suitable combined thicknesses for the layers of ribbon filaments **200**, **300**, and **400** include up to about 50% of the thickness of the ribbon filament (i.e., thickness **212**, **312**, or **412**), with particularly suitable combined thicknesses ranging from about 1% to about 25% of the thickness of the ribbon filament, and even more particularly suitable combined thicknesses ranging from about 5% to about 25% of the thickness of the ribbon filament.

Ribbon filaments **200**, **300**, and **400** illustrate suitable examples of multi-layer ribbon filaments that may be manufactured with systems **100** and **128**, and used with system **10** to build 3D models and/or support structures with reduced response times. The multi-layer nature of ribbon filaments **200**, **300**, and **400** also allow ribbon filaments to be formed from extruded sheets (e.g., sheet **90**) and attain a variety of different physical and aesthetic properties.

In additional embodiments of the present disclosure, the above-discussed cylindrical and non-cylindrical filaments may also be hollow. Since the cross-sectional area of the plastic is reduced by the missing core, the hydraulic diameter of the hollow filament may also be less than the physical diameter. Accordingly, examples of suitable hydraulic diameters for the hollow filaments of the present disclosure include those discussed above. Furthermore, the liquefier may also include a mating core to the hollow filament, so that the extrudate is heated from the inside as well as the outside.

One potential additional advantage of a hollow filament is that when hollow filament is manufactured by rapid extrusion from a compounder, it is desirably rapidly cooled before it is retained on a supply assembly (e.g., spooled). That rapid cooling process may induce diameter changes in an otherwise solid filament that may vary along its length. In comparison, if a hollow filament is rapidly cooled, the inner surface of the hollow filament can vary in diameter, leaving the outer surface more uniform.

Another potential additional advantage of a hollow filament in the form of a cylindrical shell is compliance with the filament drive mechanism. A solid filament may be close to incompressible, so that a drive roller or drive teeth may obtain too little or too much traction if the filament diameter is slightly small or large. A hollow filament, however, provides compliance so that small variations in the filament diameter are compensated by variations in the amount of compression of the hollow filament.

Yet another potential additional advantage of a hollow filament is the reduced thermal conduction in the inlet of the liquefier. When a solid filament is stationary, heat may slowly conduct up the center of the filament to the zone above the heated portion of the liquefier where the walls are relatively cool. If the filament melts there, it tends to solidify against the cooler wall, potentially causing a large axial force to restart filament motion. The rate of heat conduction up a hollow filament, however, will be slower than the rate of conduction up a solid filament due to the lack of a core.

Although the present disclosure has been described with reference to preferred embodiments, workers skilled in the art will recognize that changes may be made in form and detail without departing from the spirit and scope of the disclosure.

The invention claimed is:

1. A non-cylindrical ribbon filament for use in an extrusion-based digital manufacturing system with a ribbon liquefier to build a three-dimensional model in a layer-by-layer manner, the ribbon filament comprising:

- a composition comprising at least one extrudable material;
- a length that is continuous for at least a distance such that the ribbon filament is feedable from a supply source to the ribbon liquefier configured to melt and extrude the filament, the ribbon liquefier retained by a moveable head of the extrusion-based digital manufacturing system; and
- a cross-sectional profile of the length that is axially asymmetric and having a width and a thickness, wherein the width ranges from about 1.0 millimeter to about 10.2 millimeters, wherein the thickness ranges from about 0.51 millimeters to about 1.0 millimeter, and wherein the cross-sectional profile of the ribbon filament has a cross-sectional aspect ratio of the width to the thickness ranging from about 2.5:1 to about 20:1; wherein the ribbon filament exhibits a flexibility such that the ribbon filament does not plastically deform or fracture while retained by the supply source or when fed from the supply source to the ribbon liquefier; and wherein the ribbon filament further exhibits a Young's Modulus value ranging from about 1.0 gigapascal to about 5.0 gigapascals.

2. The ribbon filament of claim 1, wherein the at least one extrudable material comprises a thermoplastic polymeric material.

3. The ribbon filament of claim 1, wherein the cross-sectional profile is configured to mate with the ribbon liquefier having an entrance cross-sectional area A_e and a hydraulic diameter D_h with the ribbon filament, wherein $D_h < 0.95\sqrt{A_e}$.

4. The ribbon filament of claim 3, wherein $D_h < 0.90\sqrt{A_e}$, and $D_h > 0.40\sqrt{A_e}$.

5. The ribbon filament of claim 1, wherein the ribbon filament is configured to mate with the ribbon liquefier in a manner that exhibits a response time for extruding melted filament that is at least 50% faster than a response time achievable with a cylindrical filament in a cylindrical liquefier for a same thermally limited, maximum volumetric flow rate.

6. The ribbon filament of claim 1, wherein the ribbon filament further comprises a base portion having a first surface and a second surface, and a layer disposed on the first surface of the base portion, and wherein the base portion and the first surface are derived from different materials.

7. The ribbon filament of claim 1, wherein the cross-sectional aspect ratio of the width to the thickness ranges from about 3:1 to about 10:1.

8. An assembly for use in an extrusion-based digital manufacturing system with a ribbon liquefier to build a three-dimensional model in a layer-by-layer manner, the assembly comprising:

- a supply source configured to engage the extrusion-based digital manufacturing system; and
- a ribbon filament retained by the supply source, the ribbon filament comprising:
 - a composition comprising at least one extrudable material;
 - a length that is continuous for at least a distance such that the ribbon filament is feedable from the supply source

23

to the ribbon liquefier retained by a moveable head of the extrusion-based digital manufacturing system; and a rectangular cross-sectional profile of the length, which is configured to mate with the ribbon liquefier having an entrance cross-sectional area A_e and a hydraulic diameter D_h with the ribbon filament, wherein $D_h < 0.95\sqrt{A_e}$, and wherein the rectangular cross-sectional profile has a width and a thickness with a cross-sectional aspect ratio of the width to the thickness ranging from about 2.5:1 to about 20:1;

wherein the ribbon filament exhibits a flexibility such that the ribbon filament does not plastically deform or fracture while retained by the supply source; and wherein the ribbon filament further exhibits a Young's Modulus value ranging from about 1.0 gigapascal to about 5.0 gigapascals.

9. The assembly of claim 8, wherein the at least one extrudable material comprises a thermoplastic polymeric material.

10. The assembly of claim 8, wherein $D_h < 0.90\sqrt{A_e}$ and $D_h > 0.40\sqrt{A_e}$.

11. The assembly of claim 8, wherein the supply source comprises a spool on which at least a portion of the ribbon filament is wound.

12. The assembly of claim 11, wherein the supply source further comprises a container, wherein the spool is retained within the container.

13. The assembly of claim 8, wherein the width ranges from about 1.0 millimeter to about 10.2 millimeters, wherein the thickness ranges from about 0.51 millimeters to about 1.0 millimeter.

14. An assembly for use in an extrusion-based digital manufacturing system with a ribbon liquefier to build a three-dimensional model in a layer-by-layer manner, the assembly comprising:

a container configured to engage the extrusion-based digital manufacturing system;

a pathway from the container and configured to extend to a ribbon liquefier retainable by a moveable head of the extrusion-based digital manufacturing system; and

24

a ribbon filament at least partially retained within the container and feedable through the pathway from the container to the ribbon liquefier, the ribbon filament comprising:

a composition comprising at least one extrudable material;

a length;

a rectangular cross-sectional profile of the length, which is configured to mate with the ribbon liquefier having an entrance cross-sectional area A_e and a hydraulic diameter D_h with the ribbon filament, wherein $D_h < 0.95\sqrt{A_e}$, and wherein the rectangular cross-sectional profile has a width and a thickness with a cross-sectional aspect ratio of the width to the thickness ranging from about 2.5:1 to about 20:1;

wherein the ribbon filament exhibits a flexibility such that the ribbon filament does not plastically deform or fracture while retained by the supply source; and wherein the ribbon filament further exhibits a Young's Modulus value ranging from about 1.0 gigapascal to about 5.0 gigapascals.

15. The assembly of claim 14, wherein the at least one extrudable material comprises a thermoplastic polymeric material.

16. The assembly of claim 14, wherein $D_h < 0.90\sqrt{A_e}$ and $D_h > 0.40\sqrt{A_e}$.

17. The assembly of claim 14, and further comprising a spool retained in the container, wherein at least a portion of the ribbon filament is wound on the spool.

18. The assembly of claim 14, and further comprising the ribbon liquefier.

19. The assembly of claim 14, wherein the width ranges from about 1.0 millimeter to about 10.2 millimeters, wherein the thickness ranges from about 0.51 millimeters to about 1.0 millimeter.

20. The assembly of claim 14, wherein the ribbon filament further comprises a base portion having a first surface and a second surface, and a layer disposed on the first surface of the base portion, and wherein the base portion and the first surface are derived from different materials.

* * * * *