



US 20120000649A1

(19) **United States**

(12) **Patent Application Publication**

James et al.

(10) **Pub. No.: US 2012/0000649 A1**

(43) **Pub. Date: Jan. 5, 2012**

(54) **APPARATUS AND METHODS FOR IMPROVED CEMENT PLUG PLACEMENT**

(30) **Foreign Application Priority Data**

Oct. 20, 2008 (EP) 08167050.7

(76) Inventors: **Simon James**, Le Plessis Robinson (FR); **Bernard Piot**, Paris (FR); **Joel Rondeau**, Antony (FR); **Michael Montgomery**, Sugar Land, TX (US); **Gérard Daccord**, Vauhallan (FR); **Radovan Rolovic**, Sugar Land, TX (US); **Mathew Samuel**, Sugar Land, TX (US)

Publication Classification

(51) **Int. Cl.**
E21B 47/09 (2006.01)
E21B 33/12 (2006.01)

(52) **U.S. Cl.** **166/250.04**; 166/192; 166/386

(21) Appl. No.: **13/124,471**

(57) **ABSTRACT**

(22) PCT Filed: **Sep. 30, 2009**

A method and apparatus for making real-time measurements of downhole properties during cement plug placement. A wired placement conduit (30) is lowered downhole releasing a sensor package (34). The sensor package is capable of measuring downhole properties in real-time in the period while cement plug sets.

(86) PCT No.: **PCT/EP2009/007061**

§ 371 (c)(1),
(2), (4) Date: **Jun. 21, 2011**

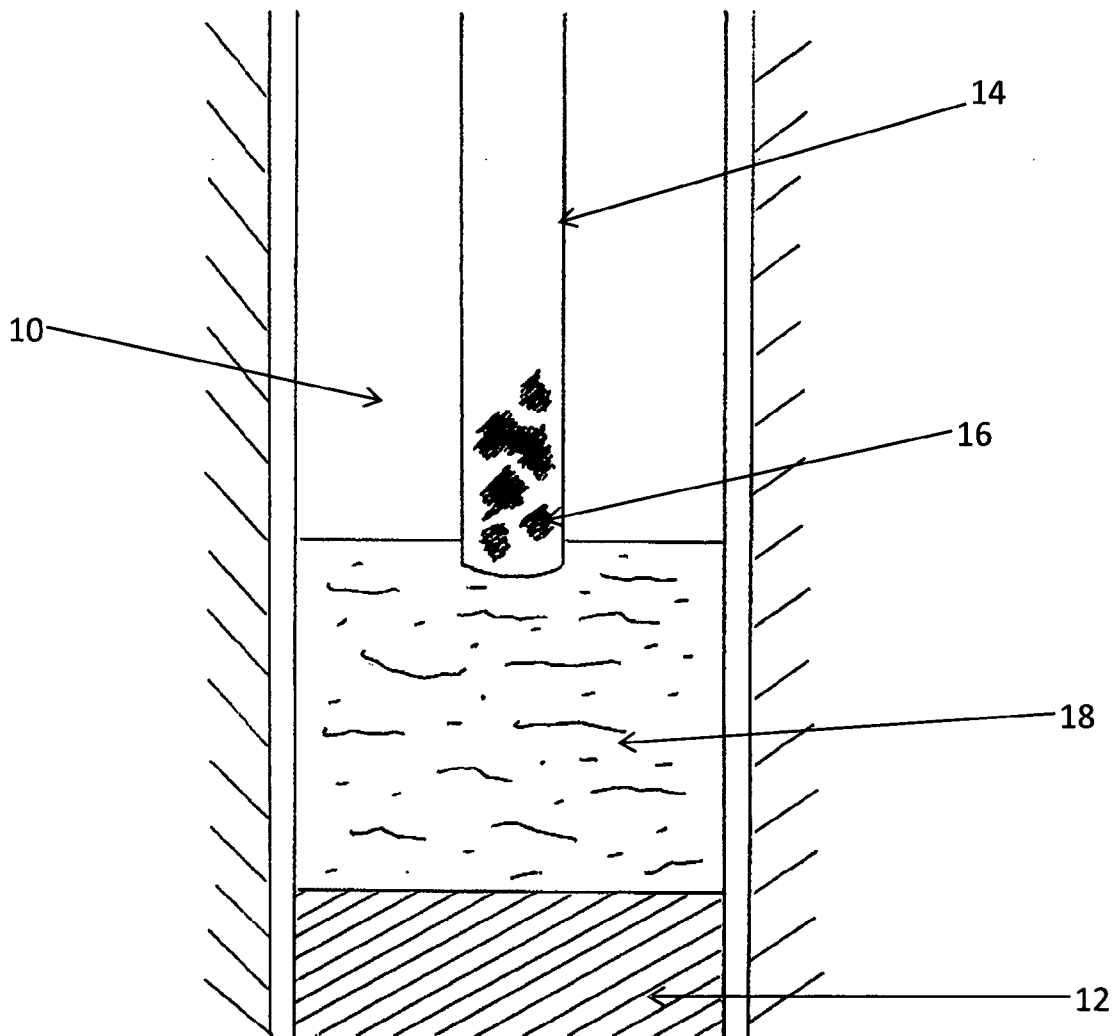

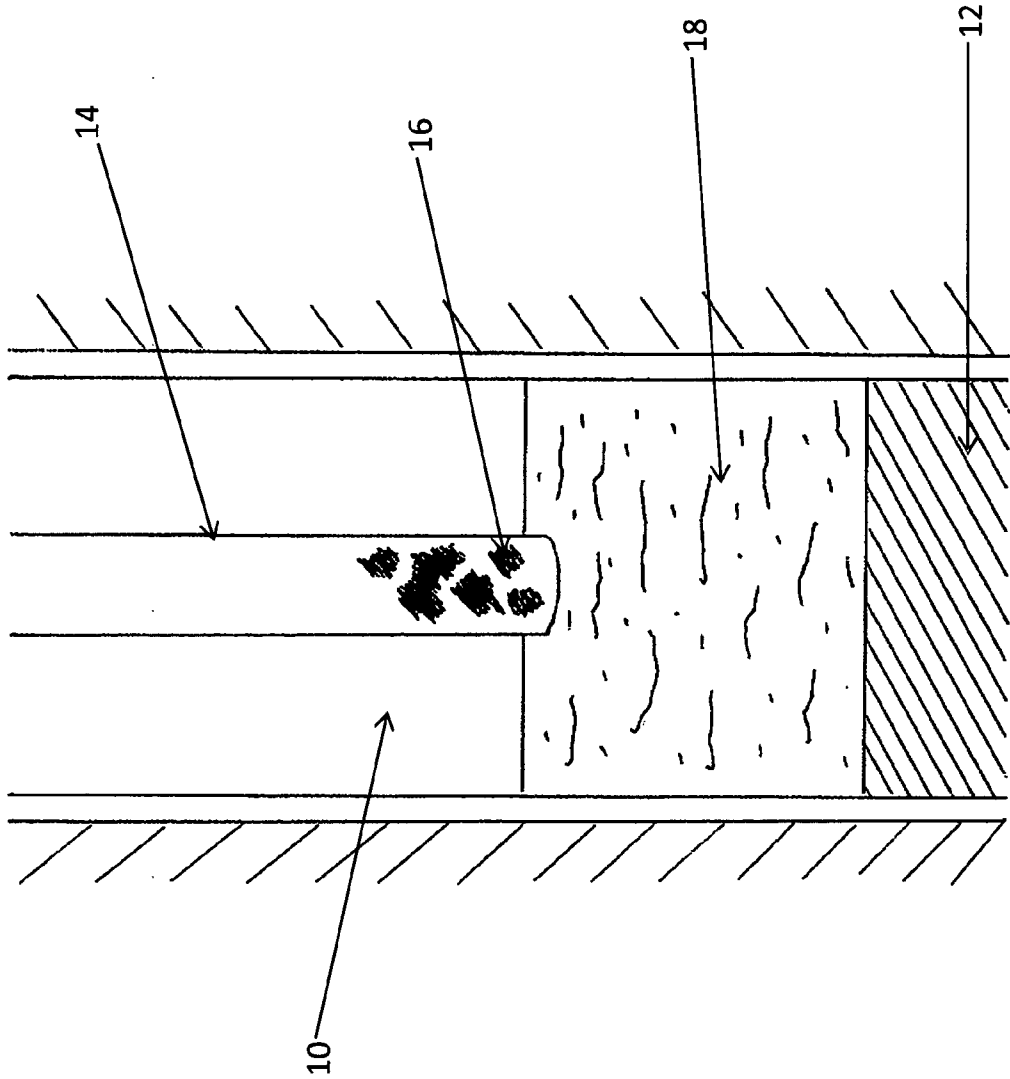

Figure 1

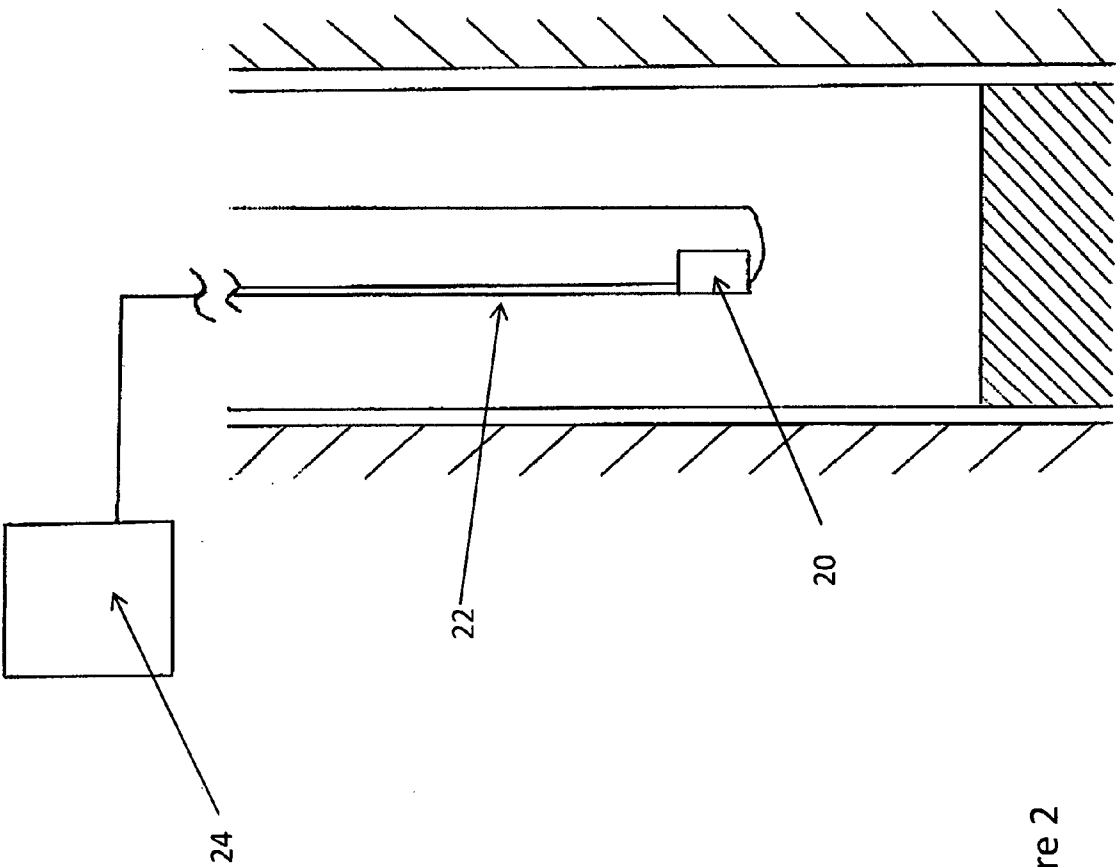

Figure 2

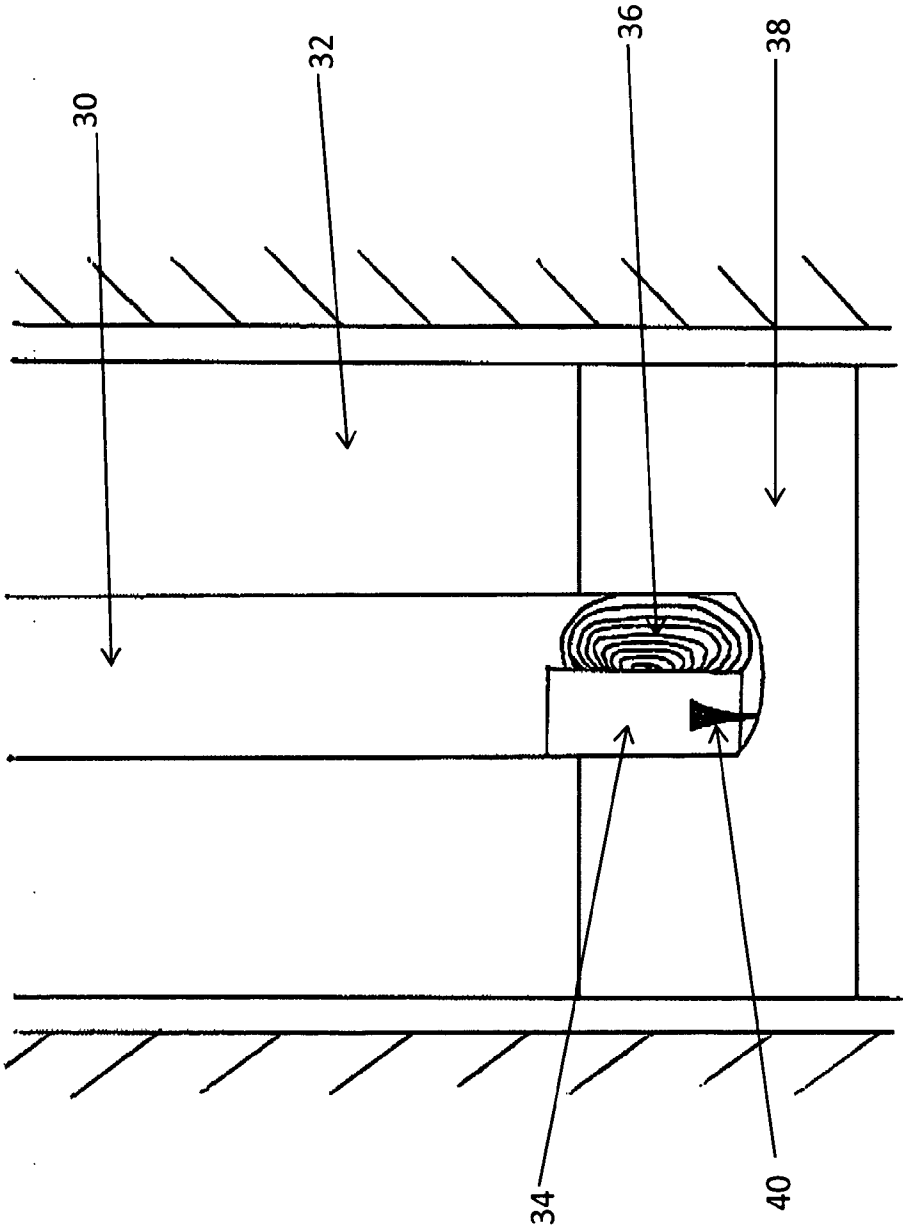

Figure 3

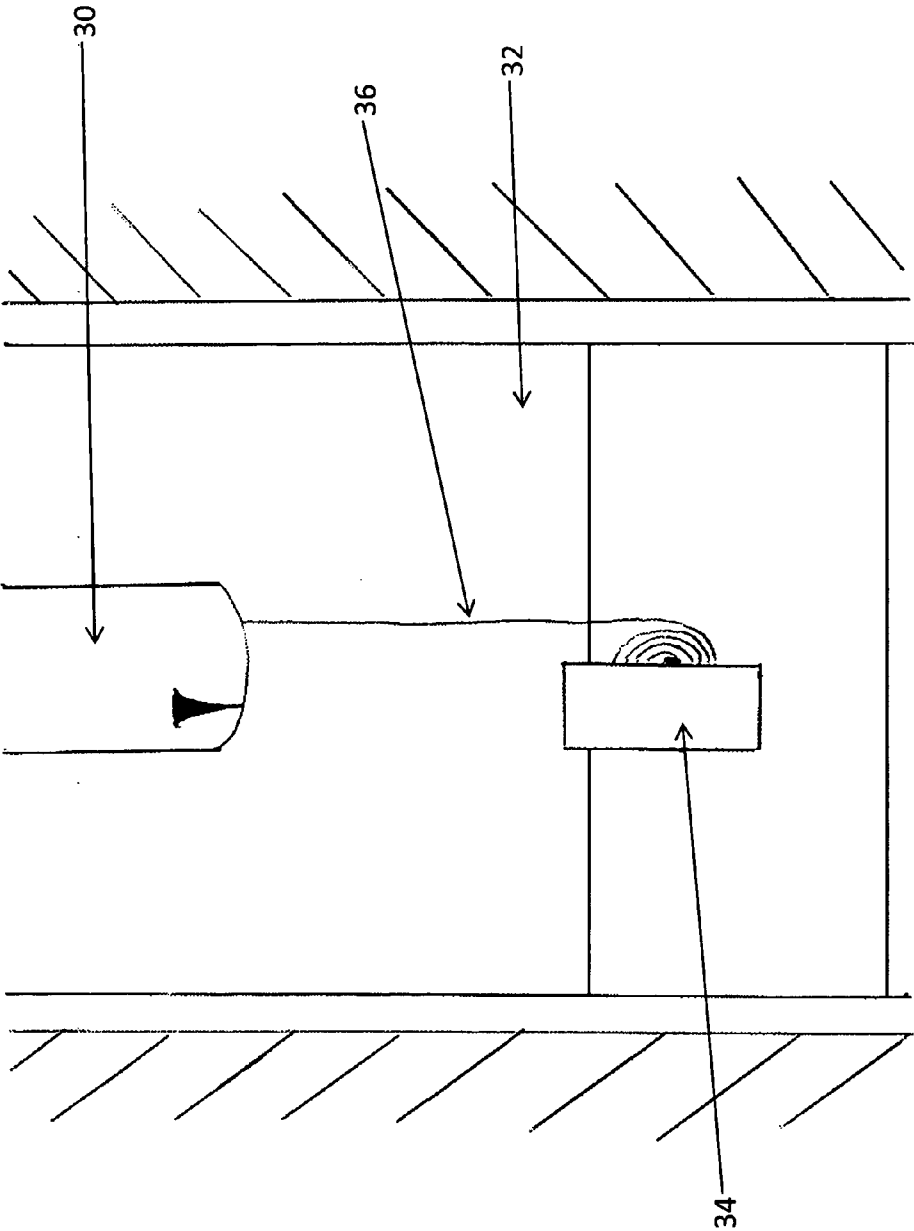

Figure 4

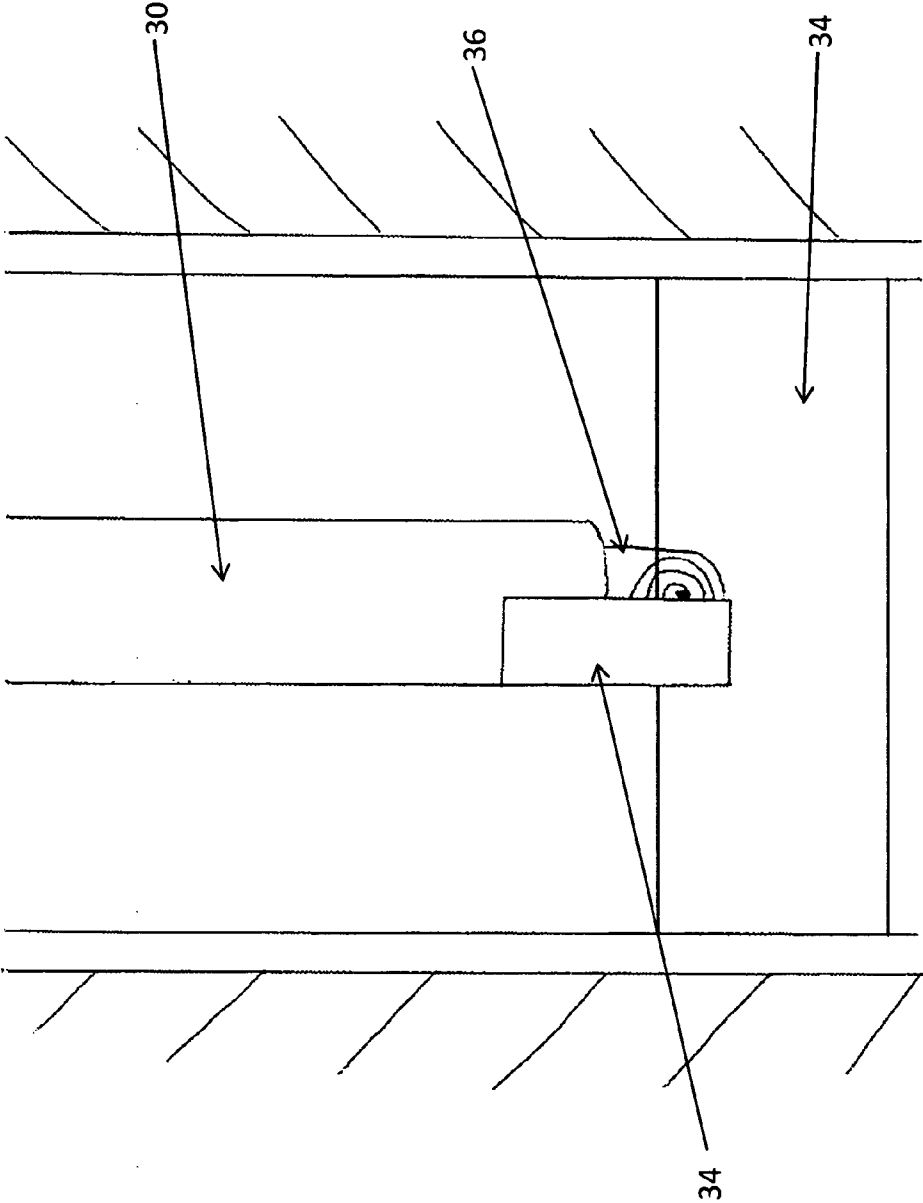

Figure 5

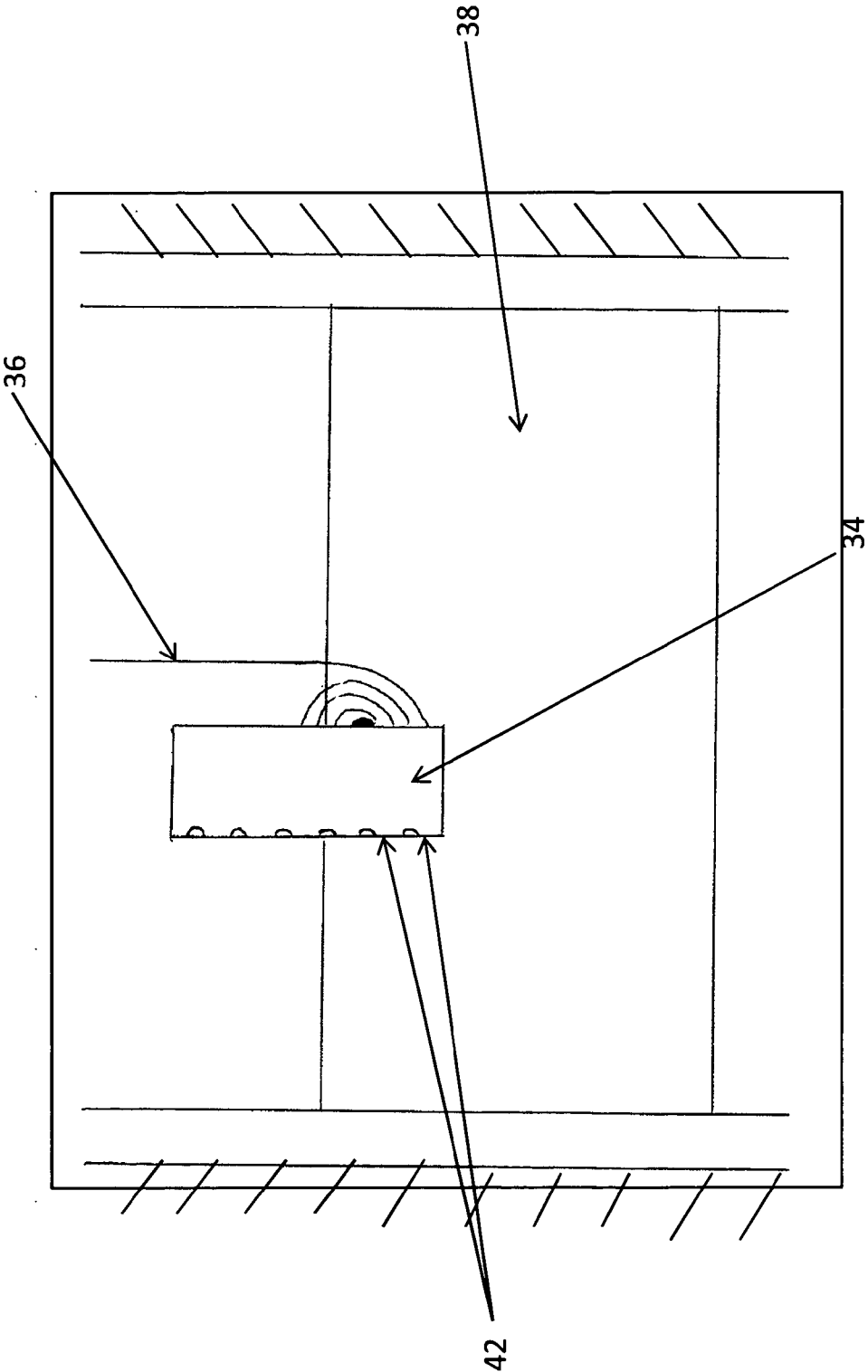

Figure 6

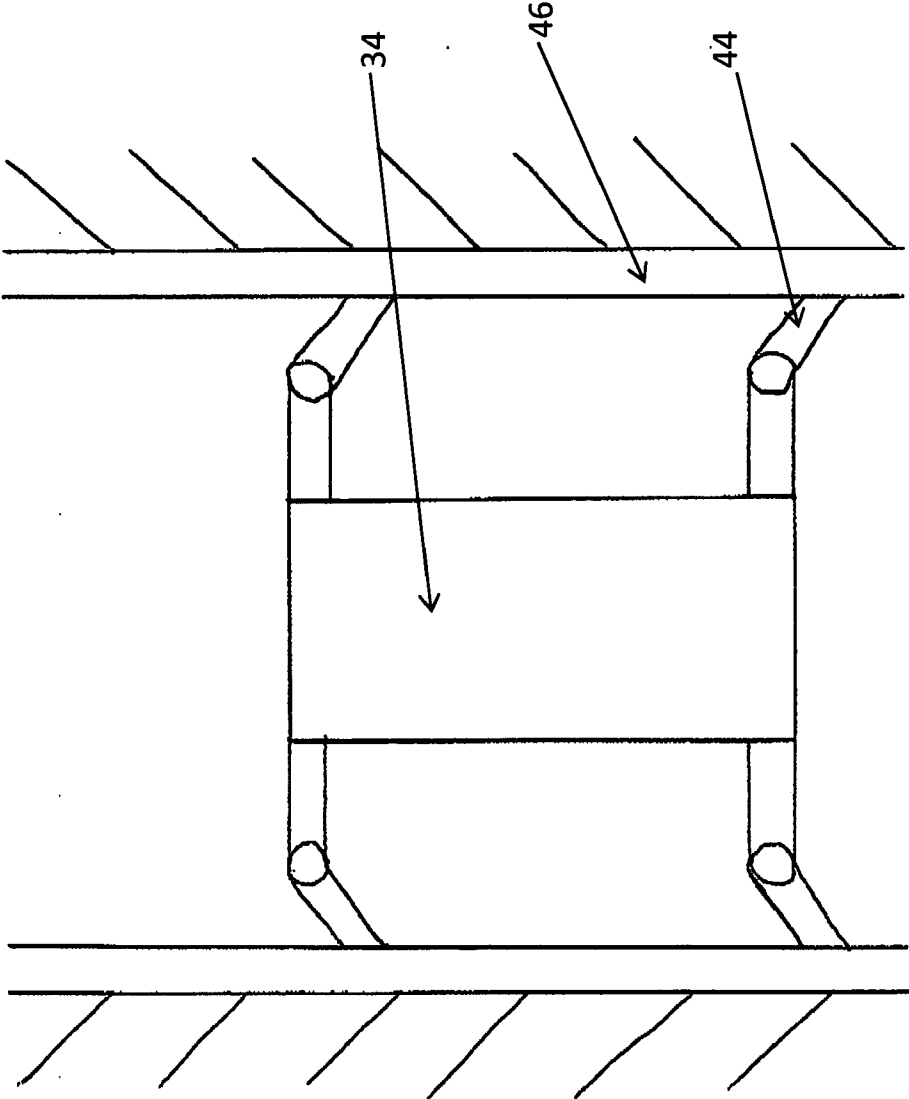

Figure 7

APPARATUS AND METHODS FOR IMPROVED CEMENT PLUG PLACEMENT

TECHNICAL FIELD

[0001] This invention relates to a method and apparatus for use during cement plug placement operations of the type encountered in wells in the oil and gas industry. In particular, the invention relates to methods using instrumented pipes and downhole sensors.

BACKGROUND ART

[0002] Cement plugs are placed in wellbores for a variety of reasons; for curing wellbore instability or losses, plugging a wellbore or a portion of it, abandoning a wellbore or a section of it, providing a base for initiating a deviation or kick-off and more. Cement plugs are constructed by pumping a relatively small amount of cement slurry down a drill pipe where it later sets solid.

[0003] FIG. 1 shows a section of a well in which a cement plug is being set. The well 10 has a viscous pill 12 set in the well 10 at the bottom of the desired plug location. The end of a drill pipe 14 is then positioned just above the pill 12 and cement 16 is pumped down the drill pipe 14 into the well to form the plug 18 on the pill 12. As the plug builds up, the drill pipe is pulled back so that it does not remain in the plug 18 when it sets. Once all of the cement has been pumped into the well 10 and the plug 18 has formed, the drill pipe 14 can be withdrawn and other operations continued.

[0004] Drilling operations resume once the cement plug has set and developed enough strength to fulfil its objective, for example to initiate side tracking or to plug conductive fractures. There is great uncertainty however about when it is safe to resume drilling operations, to mitigate the risk of resuming drilling operations too soon, it is common practice to wait extra time, typically 24 hours.

[0005] Achieving proper placement of the cement plug presents a challenge as does uncertainty in the downhole temperature; frequently too much time is allowed for the cement plug to become set before an attempt to continue well operations is made.

[0006] This invention seeks to overcome many of the challenges highlighted above by providing real-time measurements of wellbore properties during cement plug placement.

DISCLOSURE OF THE INVENTION

[0007] A first aspect of the invention provides an apparatus for placing a cement plug in a well, comprising:

- [0008] a pipe for delivering a cement slurry to a predetermined location in the well to be plugged;
- [0009] at least one sensor located at a lower end of the pipe and operable to measure parameters in the well at the predetermined location; and
- [0010] an operating system located at the surface for receiving output signals from the sensor;

wherein the sensor is configured to measure at least one parameter relevant to cement plug placement and is connected to the operating system by means of a cable.

[0011] Preferably, the sensor performs a caliper measurement for indicating hole diameter as the pipe is run into the well

[0012] A particularly preferred embodiment of the invention comprises a temperature sensor.

[0013] Particularly when the sensor is a temperature sensor, the apparatus can comprise a sensor package that is detachable from the pipe so as to remain at the predetermined

location in the well and houses a sensor cable which can be withdrawn to connect the sensor to the operating system at the surface. The sensor cable can be connected to the pipe such that withdrawal of the pipe from the well causes the sensor cable to be withdrawn from the sensor package. The sensor cable can also be connected to a cable extending along the pipe to the operating system at the surface.

[0014] The apparatus preferably further comprises a release mechanism by which the sensor package is held in the pipe, the mechanism being operable by means of a body that can be pumped through the pipe to detach the sensor package on contact with the mechanism.

[0015] An anchoring system can be provided for securing the sensor package in position in the well after it is detached from the pipe.

[0016] A second aspect of the invention provides method of placing a cement plug in a well, comprising:

- [0017] providing a pipe for delivery of the cement plug with a sensor at its end;
- [0018] introducing the pipe into the well such that its end is at a predetermined location for placement of the plug;
- [0019] operating the sensor to measure at least one parameter relevant to cement plug placement and/or to measure parameters in the well at the predetermined location; and
- [0020] sending output signals from the sensor to an operating system located at the surface by means of a cable.

[0021] The step of operating the sensor can comprise making a caliper measurement of the well, at least in the region of the predetermined location, to determine the diameter of the well.

[0022] When the sensor comprises a sensor package housing a sensor cable which can be withdrawn to connect the sensor to the operating system at the surface, the method can further comprise detaching the sensor package from the pipe so that it remains at the predetermined location in the well, and withdrawing the pipe.

[0023] When the sensor cable is connected to the pipe, the step of withdrawing the pipe from the well acts to withdraw the sensor cable from the sensor package.

[0024] The sensor cable can be connected to a cable extending along the pipe to the operating system at the surface.

[0025] In a preferred embodiment, the sensor package is held in the pipe by a release mechanism, the method comprising pumping a body through the pipe to contact the mechanism to detach the sensor package.

[0026] The sensor package can also comprise an anchoring system, the method comprising securing the sensor package in position in the well after it is detached from the pipe by operating the anchoring system.

[0027] The method according to the second aspect of the invention is preferably performed using an apparatus according to the first aspect of the invention.

[0028] The cement can comprise Portland cement, magnesium oxychloride cement, epoxy resins, geopolymers, etc. Other plugging material might be used.

[0029] Further aspects of the invention will be apparent from the following description.

BRIEF DESCRIPTION OF THE DRAWINGS

[0030] FIG. 1 shows a prior art cement plug placement operation;

[0031] FIG. 2 shows an embodiment of the invention;

[0032] FIG. 3 shows a further embodiment of the invention being lowered downhole;

[0033] FIG. 4 shows the retraction of the wired placement conduit and unrolling of the communication wire;

[0034] FIG. 5 shows an alternative embodiment whereby the wired placement conduit is only partially retracted;

[0035] FIG. 6 shows the sensor package released and deployed to the cement plug; and

[0036] FIG. 7 shows the sensor package being secured to the well casing by means of a securing device.

MODE(S) FOR CARRYING OUT THE INVENTION

[0037] FIG. 2 shows a first embodiment of the invention, in which the lower end of the drill pipe 14 is provided with a downhole measurement package 20 comprising one or more sensors for measuring parameters in the well. The sensor package is connected back to the surface by means of a wire or cable 22. The wire or cable 22 can be run along the inside or outside of the drill pipe 14, and connects to an operating system 24 at the surface. The cable 22 need not be continuous, wireless communication systems can be provided for at least part of the connection to the surface such as at pipe joints (see U.S. Pat. No. 7,019,665). The sensors in the downhole measurement package can measure various parameters.

[0038] Including a sonic (or other) caliper measurement on the wired pipe 14 can give an accurate indication of the well diameter while running in to place the cement plug. This will allow the spacer and cement volumes to be recalculated to minimise mixing (optimise interfaces while pulling out) without loss of rig time since a separate wireline caliper run may not be required. It has to be noted that the term cement shall be understood as plug forming material even if cement is the preferred material.

[0039] A temperature measurement can give an idea of how long to wait on cement. Sensitivity tests on the cement thickening time beforehand will lead to optimised waiting time.

[0040] A downhole viscosity measurement can allow the quality of the viscous plug to be evaluated. If it is insufficient a second viscous pill can be placed prior to placing cement, thus minimising the risk of slumping.

[0041] Once the cement plug is placed correctly a temperature (or other) probe can be dropped into the cement as the drill pipe 14 is being pulled out. This can be connected via thin conductor or fibre optic to the wired pipe 14. The temperature monitor can allow indication of cement setting and pull out at the earliest time. This is particularly applicable to wells where the pipe is not pulled out on a routine basis during the setting.

[0042] A further embodiment of the invention provides a method of optimising cement plug placement by use of a wired placement conduit. A sensor package is deployed into the cement plug while in its liquid state prior to setting to take measurements of down hole properties. The method comprises assembly and deployment of the wired placement conduit which permits the correct placement of the sensor package and the unrolling of the communication wire and deployment of the slurry placement device which activates the release of the sensor package. Alternatively, the wire can be coiled on the conduit/drill pipe, from which it would unroll as the pipe is withdrawn.

[0043] The wired placement conduit is assembled on the surface prior to deployment. The sensor package and communication wire rolled as a bobbin are subsequently fastened to the lower end of the wired placement conduit. The wired placement conduit is lowered downhole prior to the cement slurry being pumped.

[0044] The slurry placement device is launched from the surface through the wired placement conduit thus activating

the release of the sensor package. The release of the sensor package generates a pressure pulse. The wired placement conduit is retracted to the surface in response to the pressure pulse. The wired placement conduit may be partially retracted at a distance sufficient to ensure that the end is clear of the setting material. The communication wire is unrolled to the surface in response to the pressure pulse.

[0045] The sensor package is capable of measuring downhole properties in a similar manner to that described above. These include but are not limited to; temperature, viscosity, density, pH, resistivity measurements, differential pressure, elastic modulus and acoustic impedance. The sensor package may comprise multiple distributed sensors along the cement plug length. The data obtained from the sensor package can be used to manage the operation. For example, a viscous pill may be used in response to obtaining a low viscosity measurement indicative of slumping.

[0046] The sensor package may be attached to the well at the desired depth by a securing device. The securing device may comprise arms which permit contact with the well walls.

[0047] The wired pipe may comprise a drill string. In an alternative embodiment the wired pipe may comprise coiled tubing. Devices located on the wired placement conduit permit the measurement of the hole diameter. Sonic measurements may be taken to determine hole diameter. Alternatively calipers may be incorporated to measure hole diameter.

[0048] The communication wire may comprise a fibre optic cable and/or an electrical cable.

[0049] This invention provides a method and apparatus for deploying sensors into the liquid cement plug immediately following its placement and until it is almost set. As the material evolves with time, an operator can follow in real time its actual properties. This enables the operator to make informed decisions, based on these measured properties, of when it is possible to resume drilling operations. The amount of unproductive time is minimised.

[0050] FIG. 3 shows the wired placement conduit 30 being deployed down the wellbore 32. Prior to the wired placement conduit being lowered downhole it is assembled at the surface with the sensor package 34 and communication wire 36 rolled as a bobbin fastened to the lower end of the wired pipe 30. The wired placement conduit may be either a drill string or coiled tubing. The wired placement conduit is lowered into the hole 32 and the cement slurry is pumped. Once the cement plug 38 is in place, the slurry placement device 40 is launched from the surface through the wired placement conduit. The slurry placement device may comprise a dart, ball or other similar device. Upon reaching the end of the wired placement conduit 30, the slurry placement device 40 hits a seat which activates the release of the sensor package. 34 A pressure pulse may be generated and received at the surface providing a positive indication of the release of the sensor package. 34

[0051] FIG. 4 shows the retraction of the wired placement conduit 30 and unrolling of the communication wire 36; this occurs in response to the reception of the pressure pulse. When the sensor package 34 is released the wired pipe 30 is progressively pulled out of the hole 32. The communication wire 36 unrolls until it reaches the surface. The communication wire 36 may be an electrical wire, a fibre optic or a combination of both.

[0052] FIG. 5 shows an alternative embodiment of the invention whereby the wired placement conduit 30 may only be pulled up a certain distance to ensure that the end is clear of the setting material 38 while the sensor package 34 remains in contact with it. The communication wire 36 connects to the wired placement conduit 30 and the signal is transmitted through the wired placement conduit 30 to the surface. This

embodiment eliminates the need to retract the wired placement conduit 30 completely to the surface.

[0053] FIG. 6 shows the sensor package 34 released and deployed to the cement plug 38. The sensor package 34 is capable of measuring downhole properties. These include but are not limited to; temperature, viscosity, density, pH, differential pressure, elastic modulus and acoustic impedance. The sensor package 34 may comprise multiple sensors 42 distributed along the cement plug length.

[0054] FIG. 7 shows the sensor package 34 being secured to the borehole 32 at the required depth by means of a securing device. The deployment of anchoring arms 44 permits contact to be made with the well casing 46 to hold the package 34 in place. This avoids the package sinking out of the plug or rising to its surface, or becoming displaced by contact with other equipment.

[0055] Other changes can be made within the scope of the invention.

1. Apparatus for placing a cement plug in a well, comprising:

- a pipe for delivering a cement slurry to a predetermined location in the well to be plugged;
 - at least one sensor located at a lower end of the pipe and operable to measure parameters in the well at the predetermined location; and
 - an operating system located at the surface for receiving output signals from the sensor;
- wherein the sensor is configured to measure at least one parameter relevant to cement plug placement and is connected to the operating system by means of a cable.

wherein the sensor performs a caliper measurement for indicating hole diameter as the pipe is run into the well.

2. Apparatus as claimed in claim 1, wherein the sensor comprises a differential pressure sensor.

3. Apparatus as claimed in claim 1, wherein the sensor comprises a temperature sensor.

- 4. A method of placing a cement plug in a well, comprising:
 - providing a pipe for delivery of the cement plug with a sensor at its end;
 - introducing the pipe into the well such that its end is at a predetermined location for placement of the plug;
 - operating the sensor to measure at least one parameter relevant to cement plug placement to measure parameters in the well at the predetermined location; and
 - sending output signals from the sensor to an operating system located at the surface by means of a cable.

wherein the step of operating the sensor comprises making a caliper measurement of the well, at least in the region of the predetermined location, to determine the diameter of the well.

5. A method as claimed in claim 4 wherein the step of operating the sensor further comprises obtaining a differential pressure measurement in the fluids in the well in region of predetermined location.

6. A method as claimed in claim 4, wherein the step of operating the sensor further comprises making a temperature measurement.

7. (canceled)

8. A method for real-time measurements of the properties of a wellbore during cement plug placement comprising:

providing a pipe for delivery of the cement plug with a sensor at its end;

- introducing the pipe into the well such that its end is at a predetermined location for placement of the plug;
- operating the sensor to measure at least one parameter relevant to cement plug placement to measure parameters in the well at the predetermined location; and
- sending output signals from the sensor to an operating system located at the surface by means of a cable.

wherein the step of operating the sensor comprises making a caliper measurement of the well, at least in the region of the predetermined location, to determine the diameter of the well.

9. The method of claim 8, wherein the step of operating the sensor further comprises obtaining a differential pressure measurement in the fluids in the well in region of predetermined location.

10. The method of claim 8, wherein the step of operating the sensor further comprises making a temperature measurement.

11. The method of claim 8, wherein the calliper measurement is performed as the pipe is run into the well.

12. The apparatus of claim 2 further comprising a sensor for temperature measurement.

13. The apparatus of claim 1, wherein the sensor is detachable from the pipe.

14. The apparatus of claim 12, wherein the caliper, the differential pressure sensor and the temperature sensor are part of a sensor package that is detachable from the pipe so as to remain at the predetermined location in the well and houses a sensor cable which can be withdrawn to connect the sensor to the operating system at the surface.

15. The method of claim 5 further comprising making a temperature measurement.

16. The method of claim 9 further comprising making a temperature measurement.

17. The method of claim 15, wherein all the measurements are made by sensors located in a sensor package that is detachable from the pipe so as to remain at the predetermined location in the well and houses a sensor cable which can be withdrawn to connect the sensor to the operating system at the surface.

18. The method of claim 16, wherein, all the measurements are made by sensors located in a sensor package that is detachable from the pipe so as to remain at the predetermined location in the well and houses a sensor cable which can be withdrawn to connect the sensor to the operating system at the surface.

19. The method of claim 17, wherein the sensor cable is connected to the pipe such that withdrawal of the pipe from the well causes the sensor cable to be withdrawn from the sensor package.

20. The method of claim 17, wherein the sensor cable is connected to a cable extending along the pipe to the operating system at the surface.

21. The method of claim 4, wherein the cement plug is made from Portland cement, magnesium oxychloride cement, epoxy resins, or geopolymers, and mixtures thereof.

* * * * *