



US009571181B2

(12) **United States Patent**
Zulch, III et al.

(10) **Patent No.:** **US 9,571,181 B2**
(45) **Date of Patent:** **Feb. 14, 2017**

(54) **PROGRAMMABLE PORTABLE
ELECTRONIC DEVICE FOR AIRBORNE
OPERATIONAL COMMUNICATIONS**

FOREIGN PATENT DOCUMENTS

FR	2914802	10/2008
WO	2009058751	5/2009
WO	2013013243	1/2013

(75) Inventors: **Harold Anthony Zulch, III**, Phoenix, AZ (US); **Tom D. Judd**, Woodinville, WA (US); **Stephen Otis Hickman**, Maricopa, AZ (US)

OTHER PUBLICATIONS

European Patent Office, "Extended Search Report", "from Foreign Counterpart of U.S. Application No." May 31, 2013, pp. 1-6, Published in: EP.

(73) Assignee: **Honeywell International Inc.**, Morris Plains, NJ (US)

(Continued)

(*) Notice: Subject to any disclaimer, the term of this patent is extended or adjusted under 35 U.S.C. 154(b) by 717 days.

Primary Examiner — Brian J Gillis
Assistant Examiner — Thao Duong

(21) Appl. No.: **13/409,616**

(74) *Attorney, Agent, or Firm* — Fogg & Powers LLC

(22) Filed: **Mar. 1, 2012**

(57) **ABSTRACT**

(65) **Prior Publication Data**

US 2013/0232237 A1 Sep. 5, 2013

Embodiments of the present invention provide improved systems and methods for a programmable portable electronic device for airborne operational communications. In one embodiment, a method comprises loading application configuration information onto a storage medium on the portable electronic device from an external storage medium, the application configuration information defining an application configuration for the avionic operational data communications application and configuring an avionic operational data communications application stored in the storage medium on the portable electronic device according to the application configuration information stored in the storage medium. Further, the method includes receiving avionic operational data from an airborne server; executing the avionic operational data communications application to process the avionic operational data, wherein the execution of the avionic operational data communications application produces operational communications according to the application configuration information stored in the storage medium; and communicating the operational communications with a ground peer.

(51) **Int. Cl.**
G06F 15/177 (2006.01)
H04B 7/185 (2006.01)

(52) **U.S. Cl.**
CPC **H04B 7/18506** (2013.01)

(58) **Field of Classification Search**
CPC H04L 67/02; H04L 67/34; H04L 69/329; H04L 29/06; H04L 29/12066; H04L 41/0803; H04L 67/12; H04L 67/06; H04L 2012/4028; H04L 67/04; H04L 12/2856
See application file for complete search history.

(56) **References Cited**

U.S. PATENT DOCUMENTS

6,154,636 A 11/2000 Wright et al.
7,512,714 B2 3/2009 Eckert

(Continued)

17 Claims, 4 Drawing Sheets

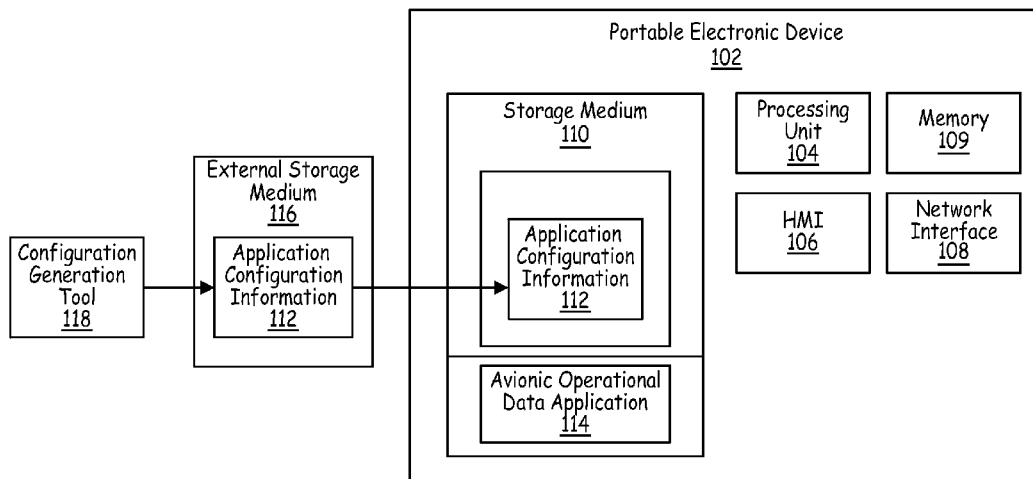

(56)

References Cited

U.S. PATENT DOCUMENTS

7,729,263	B2	6/2010	True et al.	
8,433,475	B2	4/2013	Corbefin	
8,935,306	B2	1/2015	Corbefin	
2002/0111720	A1*	8/2002	Holst et al.	701/3
2003/0003872	A1*	1/2003	Brinkley et al.	455/66
2004/0162648	A1	8/2004	Bontrager et al.	
2005/0267860	A1*	12/2005	Benguigui	707/1
2006/0085308	A1*	4/2006	Metzger	G06Q 10/087 705/34
2008/0195861	A1	8/2008	Salomone	
2009/0058682	A1	3/2009	True	
2009/0133112	A1	5/2009	Kauffman et al.	
2009/0254605	A1*	10/2009	Clavel	709/203
2009/0310530	A1	12/2009	Cerra, II et al.	
2010/0121938	A1*	5/2010	Saugnac	709/218
2012/0265372	A1*	10/2012	Hedrick	701/3
2012/0321087	A1	12/2012	Fleischman et al.	

OTHER PUBLICATIONS

“About G3CARS”, “<http://www.g3cars.com/about.html> accessed Dec. 14, 2011”, , pp. 1-2.

U.S. Patent and Trademark Office, “Office Action”, “U.S. Appl. No. 14/463,488”, Mar. 24, 2016, pp. 1-21, Published in: US.

U.S. Patent and Trademark Office, “Final Office Action”, “U.S. Appl. No. 14/463,488”, Oct. 6, 2016, pp. 1-17, Published in: US.

* cited by examiner

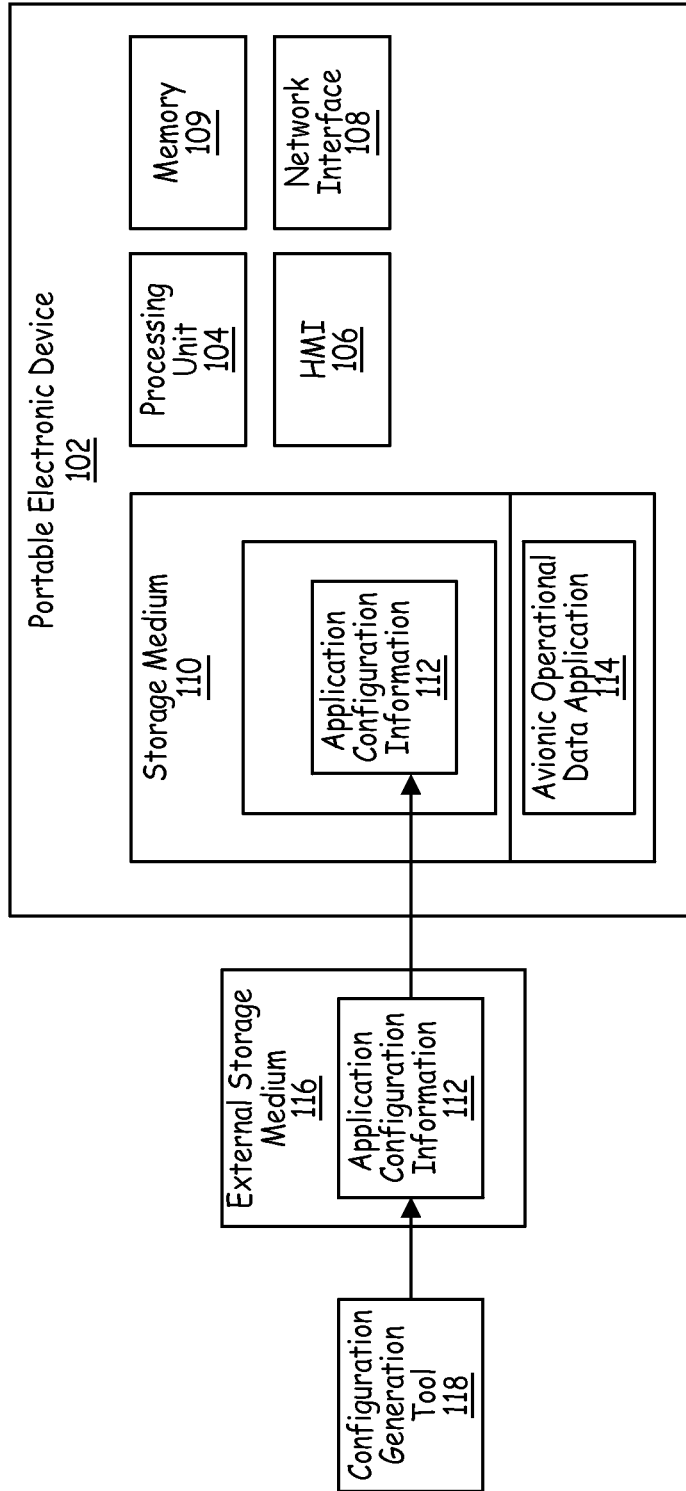

FIG. 1

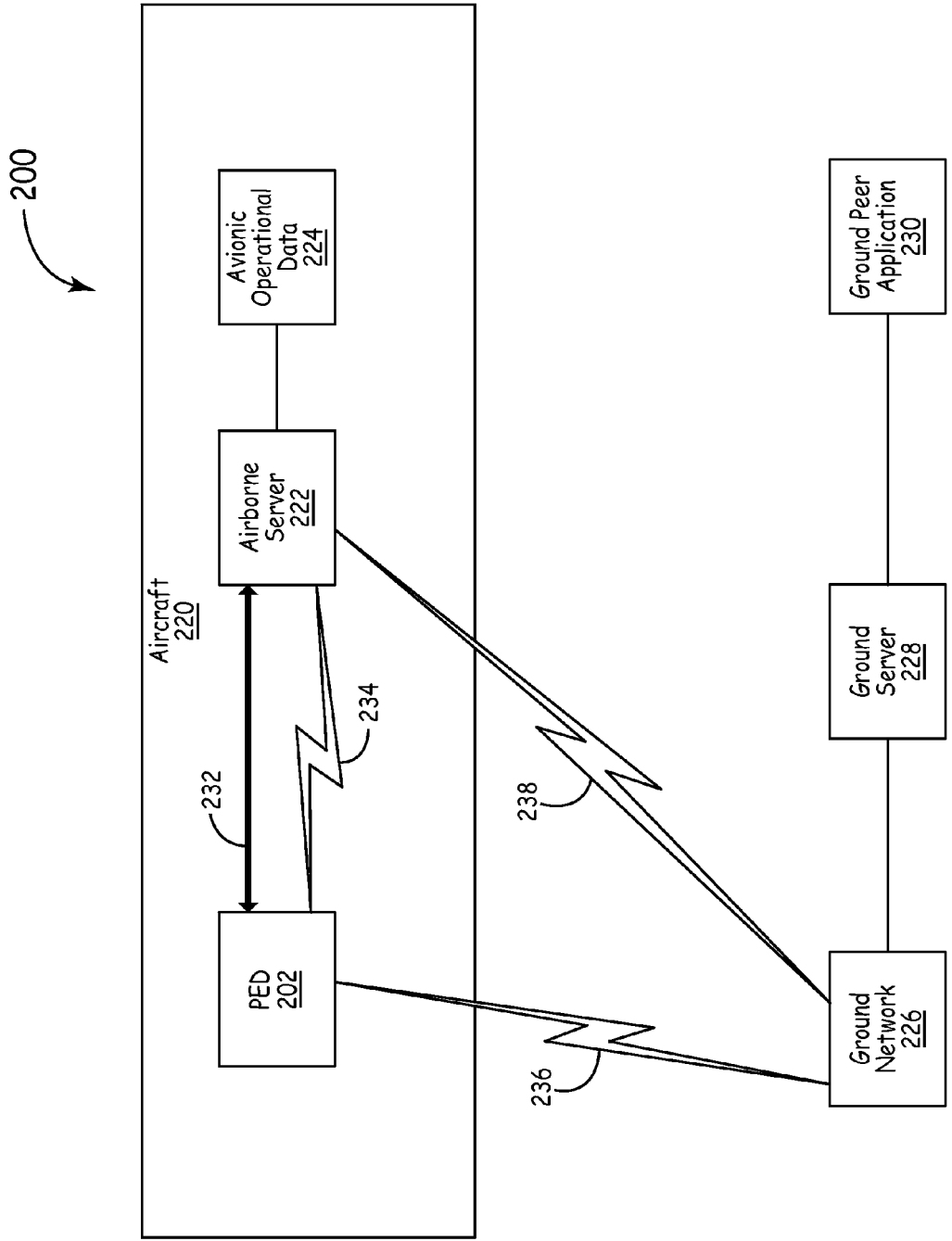

FIG. 2

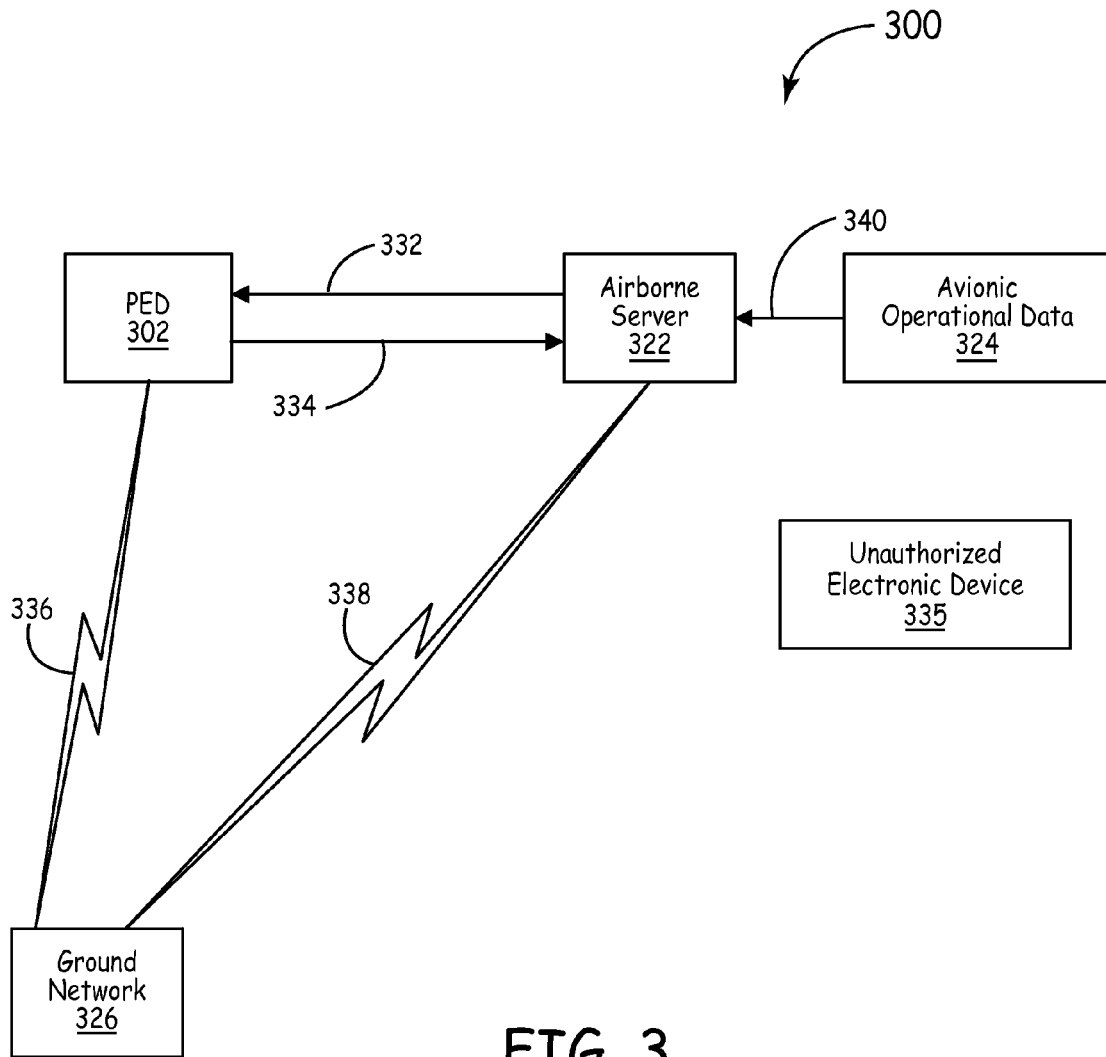

FIG. 3

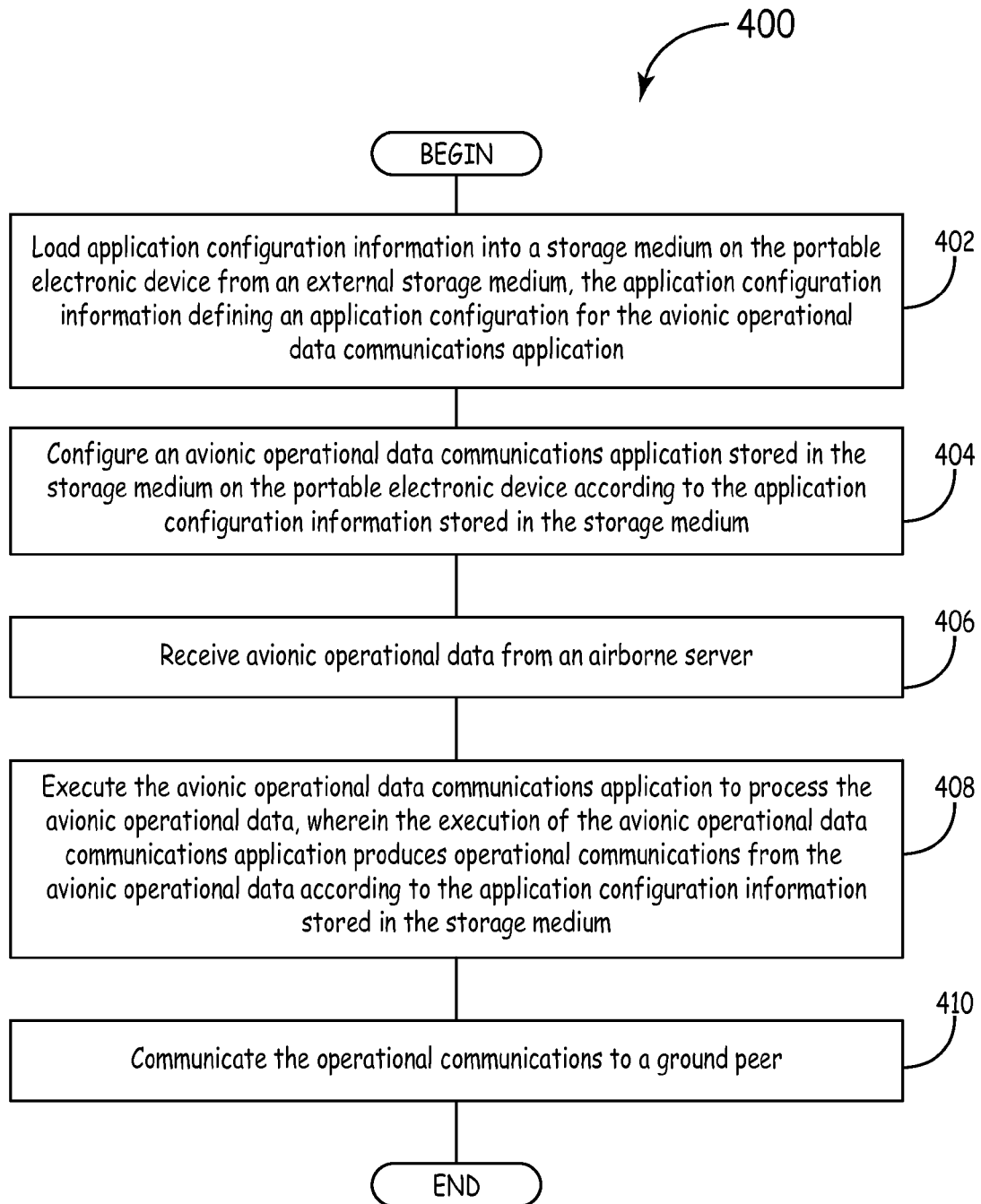

FIG. 4

1

**PROGRAMMABLE PORTABLE
ELECTRONIC DEVICE FOR AIRBORNE
OPERATIONAL COMMUNICATIONS**

BACKGROUND

Aircraft operators and pilots use avionic operational data and operational communication to improve the efficiency of aircraft fleet operations. Typically, during the flight of an airplane, aircraft systems produce avionic operational data that is available for display to a pilot on cockpit displays and communicated as airborne operational communications (AOC) to a fleet control center over existing aerospace networks like an aircraft communications addressing and reporting system (ACARS) network. However, while operators are able to define AOC using configurable databases, the access of avionic operational data for the AOC is limited by ACARS datalink communication. For example, ACARS is an ASCII network and the transmission and receipt of the avionic operational data over a network like ACARS is restricted in bandwidth and as to types of messaging, format, size, and capabilities. Further, access to the avionic operational data is limited to cockpit instrumentation.

SUMMARY

The embodiments of the present disclosure provide systems and methods for a programmable portable electronic device for airborne operational communications and will be understood by reading and studying the following specification.

Embodiments of the present invention provide improved systems and methods for a programmable portable electronic device for airborne operational communications. In one embodiment, a method comprises loading application configuration information onto a storage medium on the portable electronic device from an external storage medium, the application configuration information defining an application configuration for the avionic operational data communications application and configuring an avionic operational data communications application stored in the storage medium on the portable electronic device according to the application configuration information stored in the storage medium. Further, the method includes receiving avionic operational data from an airborne server; executing the avionic operational data communications application to process the avionic operational data, wherein the execution of the avionic operational data communications application produces operational communications from the avionic operational data according to the application configuration information stored in the storage medium; and communicating the operational communications with a ground peer.

DRAWINGS

Understanding that the drawings depict only exemplary embodiments and are not therefore to be considered limiting in scope, the exemplary embodiments will be described with additional specificity and detail through the use of the accompanying drawings, in which:

FIG. 1 is a block diagram of an exemplary embodiment of a programmable portable electronic device for airborne operational communications.

FIG. 2 is a block diagram of an exemplary embodiment of a system for communicating avionic operational data to a portable electronic device and with a ground peer application.

2

FIG. 3 is a block diagram of an exemplary embodiment of security measures for preventing electronic devices other than a designated portable electronic device from accessing the avionic operational data and the airborne operational communications.

FIG. 4 is a flow diagram of an exemplary embodiment of a method for communicating avionic operational data to a programmable portable electronic device.

In accordance with common practice, the various described features are not drawn to scale but are drawn to emphasize specific features relevant to the exemplary embodiments.

DETAILED DESCRIPTION

In the following detailed description, reference is made to the accompanying drawings that form a part hereof, and in which is shown by way of illustrating specific illustrative embodiments. However, it is to be understood that other embodiments may be utilized and that logical, mechanical, and electrical changes may be made. Furthermore, the method presented in the drawing figures and the specification is not to be construed as limiting the order in which the individual steps may be performed. The following detailed description is, therefore, not to be taken in a limiting sense.

FIG. 1 is a block diagram of an exemplary embodiment of a portable electronic device (PED) **102** that is configured for operational communications. PED **102** includes tablet computers, laptop computers, personal digital assistants, smart phones, and the like. In the exemplary embodiments of the present disclosure, PED **102** is configured to provide a configurable avionic operational data communications application **114**. Avionic operational data communications application **114** is an application that can be configured according to design requirements to control operational communications. In at least one embodiment, operational communications include processed avionic operational data that is communicated from an aircraft to a fleet control center to support fleet operation. In a further embodiment, avionic operational data communications application **114** allows a pilot to access avionic operational data through PED **102** that includes operation communications.

In the exemplary embodiment shown in FIG. 1, avionic operational data communications application **114** is stored (or otherwise embodied) on or in an appropriate non-transitory storage medium or media **110** (such as flash or other non-volatile memory, magnetic disc drives, and/or optical disc drives). At least a portion of the program instructions for avionic operational data communications application **114** are read from the storage medium **110** by a processing unit **104** for execution thereby. Computing system **100** also includes memory **109** for storing the program instructions (and any related data) during execution by processing units **108** in processing cluster **102**. Memory **109** comprises, in one implementation, any suitable form of random access memory (RAM) now known or later developed, such as dynamic random access memory (DRAM). In other embodiments, other types of memory are used. Further, in some exemplary implementations, each processing unit in processing cluster **102** has a separate memory **109** dedicated to storing the program instructions during execution on the associated processing unit.

In certain embodiments, when the processing unit **104** executes the instructions that comprise avionic operational data communications application **114**, the executing instructions command the processing unit **104** to send data to and receive information from a human machine interface (HMI)

106 associated with airborne operational communications between the airborne operational communications application and the ground airborne operational communications peer. For example, in at least one implementation, when processing unit **104** sends data to HMI **106**, HMI **106** renders the received data as a visual display to a user. Further, HMI **106** receives commands from a user, which HMI **106** transmits to processing unit **104**. Processing unit **104** handles the received commands as directed by the executing avionic operational data communications application **114**. In one exemplary implementation of the present embodiment, when the PED **102** is a tablet computer or other similar electronic device, HMI **106** includes a touch screen that displays avionic operational data to a user and receives user commands for transmitting the user commands to the processing unit **104**.

In a further embodiment where the PED **102** is used on an aircraft, the PED **102** receives avionic operational data related to an aircraft via a network interface **108**. Network interface **108** connects to an airborne server via an Ethernet cable, a wireless internet connection, a universal serial bus, a broadband communication link, or the like. By receiving avionic operational data through network interface **108**, PED **102** acquires access to avionic operational data from an airborne server that is independent of cockpit displays and instrumentation. In one implementation, because the PED **102** is able to process the avionic operational data and provide operational communications independently of cockpit instrumentation, a pilot or flight crew member can use PED **102** to process avionic operational data and provide operational communications when the pilot is outside of the cockpit. One potential benefit of being able to provide operational communications independently of aircraft instrumentation is that a flight crew member can perform operational communications related tasks outside the cockpit, which allows the flight crew members to more efficiently allocate their time to critical flight tasks.

As mentioned above, avionic operational data communications application **114** is configurable to certain design requirements. The term “configurable,” as used herein, refers to an avionic operational data communications application that is customized for a particular user, where the user is an aircraft/fleet operator, a conglomeration of airlines, an organization, a pilot, a flight crew, a maintenance crew, or the like. In one example that implements a configurable application, a particular aircraft or fleet operator may desire that certain avionic operational data be presented to the pilot, while other avionic operational data is transmitted to a ground server, while further data may be processed according to aircraft/fleet operator specifications. Alternatively, the configurable application can present the same avionic operational data to the pilot, aircraft/fleet operators. Avionic operational data communications application **114** is configurable to suit the particular needs of the particular operator. To imbue avionic operational data communications application **114** with configurability, PED **102** includes application configuration information **112** stored in storage medium **110**. Alternatively, PED **102** includes multiple storage mediums **110** where a first storage medium **110** stores the application configuration information **112** and a second storage medium **110** stores avionic operational data communications application **114**. Application configuration information **112** includes information that processing unit **104** accesses when executing avionic operational data communications application **114**. For example, in one implementation, application configuration information **112** defines the format and content of uplink and downlink messages, how uplink messages are

displayed, and how downlink messages are created and sent. Further, the application configuration information **112** defines what data is entered by the operator, the processing of avionic operational data, local parameter definitions, and the like. In one exemplary implementation, when processing unit **104** executes avionic operational data communications application **114**, avionic operational data communications application **114** directs processing unit **104** to acquire configuration information from application configuration information **112** stored in storage medium **110**. Processing unit **104** then uses the application configuration information **112** to determine how to configure avionic operational data communications application **114** for processing operational communications. For example, the processing unit **104** uses the application configuration information **112** to define the format and content of uplink and downlink messages, how uplink messages are displayed on PED **102**, and how downlink messages are created and sent by PED **102**. Further, the application configuration information **112** defines what data is entered by the operator, the processing of avionic operational data, local parameter definitions, and the like.

In at least the present exemplary embodiment, the application configuration information **112** is loaded into storage medium **110** on PED **102** from an external storage medium **116** that exists externally to PED **102**. In at least one example, external storage medium **116** is an appropriate non-transitory storage media, such as flash or other non-volatile memory, magnetic disc drives, and/or optical disc drives. External storage medium **116** stores the application configuration information **112** in a database or a file so that multiple PEDs **102** can access external storage medium **116** to acquire the application configuration information **112**. For instance, a fleet having a fleet specific configuration, stores the application configuration information **112** in external storage medium **116** that exists externally to PED **102**, where external storage medium **116** is accessible by multiple PEDs **102**. For example, external storage medium **116** is stored on a server that is controlled by a fleet operator. In an alternative implementation, application configuration information **112** is distributed on a disk, a USB drive, or the like for loading of the application configuration information **112** onto individual PEDs **102**. For each PED **102** that executes avionic operational data communications application **114** associated with a particular fleet, the application configuration information **112** stored on external storage medium **116** is loaded into storage medium **110** on PED **102**.

In certain embodiments, a configuration generation tool **118** creates the application configuration information **112** stored in external storage medium **116**. Configuration generation tool **118** is a tool that is operated by the fleet or a third party user that creates application configuration information **112** that is commonly shared among multiple PEDs **102** within a fleet or other group of users. For example, a fleet uses configuration generation tool **118** such as a ground based software tool or a reconfiguration tool to create the application configuration information **112** stored in external storage medium **116**. The configuration generation tool **118** defines the format and content of uplink and downlink messages, how uplink messages are displayed on PED **102**, and how downlink messages are created and sent by PED **102**. Further, the application configuration information **112** defines what data is entered by the operator, the processing of avionic operational data, local parameter definitions, and the like. By controlling multiple aspects of the application configuration information **112** available through external storage medium **116**, the configuration generation tool **118** allows an organization to configure the processing of avionic

operational data and control of operational communications through avionic operational data communications application 114 on multiple PEDs 102 for multiple aircraft in the fleet.

FIG. 2 is a block diagram illustrating a system 200 for communicating avionic operational data to a PED 202 and to a ground server 228. System 200 includes an aircraft 220 that communicates with a ground network 226. Aircraft 220 includes a PED 202 that operates similarly to PED 102 described above in relation to FIG. 1. During the operation of aircraft 220, sensors and control systems on aircraft 220 create avionic operational data 224 which is stored in a data repository on aircraft 220. Avionic operational data 224 includes information that is used by the pilots of the aircraft to monitor the status of the airplane and help operate the aircraft. Alternatively, avionic operational data 224 includes aircraft data information related to the operation of the aircraft and associated fleet. Further, ground based applications and users can use avionic operational data 224 to further track the status of the airplane and control fleet operations.

In at least one exemplary embodiment, to provide access to the avionic operational data 224, aircraft 220 includes an airborne server 222 that provides for the communication of data on aircraft 220. The airborne server 222 provides access to avionic operational data 224 and controls the transmission of information to other devices on aircraft 220. For example, airborne server 222 provides access to the information that is transmitted to cockpit devices and PED 202. In certain embodiments, airborne server 222 transmits avionic operational data 224 to PED 202. Further, PED 202 is able to transmit uplink message's operational data to airborne server 222 for distribution to other avionic devices.

In certain embodiments, PED 202 includes a processing unit 104 that processes the received avionic operational data 224 during the execution of avionic operational data communications application 114. In at least one exemplary implementation, the execution of avionic operational data communications application 114 produces data intended for transmission to a ground peer application 230 as part of a downlink. PED 202 transmits the data produced for ground peer application 230 through a network that connects to ground peer application 230. The term "ground peer application," as used herein, refers to an application that executes on a ground computer that is configured to process data that results from the execution of avionic operational data communications application 114 on PED 202 and also transmits uplink data to the PED 202 through an uplink message compatible with the defined message definition in the application configuration information stored in the storage medium and processed on the peer PED 202. In one example, PED 202 communicates produced data to ground peer application 230 with a ground network 226 through a communication link 236 between PED 202 and ground network 226. In an alternative example, PED 202 transmits the produced data to airborne server 222 over wireless connection 234 or cable connection 232. Airborne server 222 transmits data received from PED 202 that is intended for a ground peer application 230 over communication link 238 to ground network 226. In a further example, airborne server 222 receives uplink data from the ground peer application 230 over communication link 238 and ground network 226. The airborne server 222 transmits the uplink data to the PED 202. PED 202 receives the uplink data and processes the uplink data according to the application configuration information 112, which, in at least one implementation, controls the display of the uplink messages and the

manner in which the uplink data is presented to an HMI. In one exemplary implementation, the processing unit 104 controlling storage medium 110 in FIG. 1 can indicate when avionic operational data is to be updated by receiving the avionic operational data from the airborne server 222. Communication links 238 includes cellular communication links, broadband SATCOM links, ACARS links (such as VHF, traditional aeronautical SATCOM, and HF), WiFi, a wired link IF on the ground, and the like.

In at least one exemplary embodiment, ground network 226 receives and transmits downlinks and uplinks which include operational data and communicates the data to a ground server 228. Ground server 228 transmits the downlink messages (which may include operational data) received from the PED 202 via the ground network 226 to a ground peer application 230. In some implementations, ground peer application 230 uses the received data from PED 202 to support organizational operations. In one exemplary implementation, ground peer application 230 receives data that represents out, off, on, and in (OOOI) times from an aircraft. An organization can use the OOOI times to determine the time in the air for a pilot when determining the earnings of the pilot.

PED 202 allows a pilot to use a readily available device with a configurable application stored thereon. The application allows the pilot to access avionic operational data 224 on PED 202. The PED 202 also transmits operational messages (including operational data) to a ground server 228 and accompanying ground peer application 230 to facilitate airline operations. In a further embodiment, PED 202 also connects to ground server 228 when PED 202 accompanies a pilot who has left aircraft 220. As the pilot is still able to communicate with ground peer application 230 through PED 202 after the aircraft has landed, the pilot is able to perform certain tasks involving avionic operational data 224 when the pilot is away from the cockpit of aircraft 220.

FIG. 3 is block diagram illustrating an exemplary embodiment of security measures for preventing an unauthorized electronic device from accessing avionic operational data 324 as it is communicated to a PED 302. As discussed above, aircrafts produce avionic operational data 324 that is used by pilots of an aircraft and airlines to control flight operations. Further as discussed above, airborne server 322 receives avionic operational data 324 from systems that function on an aircraft. In at least one exemplary implementation, airborne server 322 controls the dissemination of avionic operational data 324 to electronic devices used on an aircraft, such transmitting avionic operational data 324 to PED 302. In transmitting avionic operational data 324 from aircraft systems to airborne server 322 and then onto the PED 302, security measures are used to prevent an unauthorized electronic device 335 from accessing the network.

Unauthorized electronic device 335 could attempt to affect the transmission of avionic operational data 324. For example, unauthorized electronic device 335 could attempt to access the avionic operational data 324, emulate airborne server 322 or PED 302, transmit corrupting data to PED 302, airborne server 322, and aircraft systems that produce avionic operational data 324, and the like. In the communication of avionic operational data 324, certain security measures are used to prevent unauthorized electronic device 335 from accessing the avionic operational data 324. In one example of a security measure, the communication of avionic operational data 324 to airborne server 322 over communication link 340 is unidirectional, that is avionic operational data 324 is transmitted to airborne server 322 over link 340 from the avionic systems but data is not

received by the avionic systems from airborne server 322. In another example of a security measure, airborne server 322 transmits avionic operational data to PED 302 over link 332 and receives data from PED 302 over link 334, and isolates the processing of data received over link 334 from the processing of data that is transmitted over link 332. Because the received data is isolated from the transmitted data, airborne server 322 is able to limit the ability of received data from affecting the operation of an aircraft. Further, airborne server 322 verifies that PED 302 is a trusted electronic device before initiating communications with PED 302. To verify that PED 302 is a trusted electronic device, PED 302 provides an identification key or a user must login to a communication session with airborne server 322. In at least one exemplary embodiment, the PED and airborne server 322 communicate over a virtual private network, provide message authentication, and encrypt message transmissions. Similarly, PED 302 is prevented from establishing communication links with unauthorized electronic device 335. The various above mentioned security measures along with other security measures aid in preventing unauthorized electronic device 335 from accessing avionic operational data 324.

In at least one exemplary embodiment, communication link 336, between PED 302 and ground network 326, and communication link 338, between airborne server 322 and ground network 326, are subject to similar security measures described above in relation to the communication of data between airborne server 322 and PED 302. The security measures protecting ground network 326 prevent unauthorized electronic device 335 from accessing avionic operational data 324 and operational communications transmitted between an aircraft and a ground network 326.

FIG. 4 is a flow diagram of an exemplary embodiment of a method 400 for communicating avionic operational data to a programmable portable electronic device. Method 400 begins at block 402, where application configuration information is loaded into a storage medium on the portable electronic device from an external storage medium, the application configuration information defining an application configuration for the avionic operational data communications application. For example, application configuration information is generated by a configuration generation tool and stored in an external storage medium stored externally to a PED. In some implementations, the external storage medium exists on a server that is accessible to multiple PEDs. Alternatively, the external storage medium is a portable storage medium like a floppy disk, a USB flash drive, or the like. Method 400 proceeds at block 402, where an avionic operational data communications application stored in the storage medium on the PED is configured according to the application configuration information stored in the storage medium. For example, the PED includes an avionic operational data communications application that processes avionic operational data. Further the avionic operational data communications application is configured by reading a defined configuration from the application configuration information stored in the storage medium on the PED.

Method 400 proceeds at block 406, where avionic operational data is received from an airborne server. For example, an airborne server gathers avionic operational data from aircraft systems (for example, sensors and controls on the aircraft) and provides the avionic operational data to the PED. In at least one implementation, security measures are used to prevent a non-network electronic device from accessing the avionic operational data and operational com-

munications that are transmitted between the PED, the airborne server, and the aircraft systems. In at least one example, the airborne server only communicates with recognized PEDs.

Method 400 proceeds at block 408, where the avionic operational data communications application is executed to process the avionic operational data, wherein the execution of the avionic operational data communications application produces operational communications from the avionic operational data according to the application configuration information stored in the storage medium. For example, upon the reception of the avionic operational data from the airborne server, the avionic operational data communications application directs a processing unit on the PED to process the avionic operational data according to application configuration information stored in the storage medium. The application configuration information provides information that directs the avionic operational data communications application to produce operational communications based on the avionic operational data. For example, the application configuration information defines the format and content of uplink and downlink messages, how uplink messages are displayed, and how downlink messages are created and sent. Further, the application configuration information defines what data is entered by the operator, the processing of avionic operational data, local parameter definitions, and the like.

Method 400 proceeds at block 410, where the operational communications are communicated with a ground peer. For example, the avionic operational data communications application processes the received avionic operational data to control the operational communications, the avionic operational data communications application communicates with a ground peer to both transmit and receive operational communications. In at least one implementation, the ground peer is an application that is configured to collect the operational communications and use the collected data to control fleet operations. In certain embodiments, to communicate with the ground peer, the avionic operational data communications application on the PED communicates via an airborne server. The PED communicates directly with the airborne server, which then communicates with a ground peer through a communication link formed between the airborne server and a ground network, which connects to the ground peer. In another embodiment, the avionic operational data communications application directs the PED to directly communicate with the ground peer through the ground network using a communication link available to the PED. In another embodiment, the avionic operational data communications application directs the PED to communicate with a communication transceiver, where the communication transceiver relays operational communications between the ground peer and the PED.

Example Embodiments

Example 1 includes a communication system, the system comprising an external storage medium storing operational application configuration information defining an application configuration for an avionic operational data communications application; an airborne communication system configured to perform operational communications, the airborne communication system comprising a portable electronic device, the portable electronic device hosting the avionic operational data communications application that produces the operational communications from avionic operational data, wherein the avionic operational data com-

munications application is configured by the application configuration information stored on the personal electronic device, wherein the application configuration information is loaded into a storage medium on the portable electronic device from the external storage medium; and an airborne server coupled to the portable electronic device, wherein the airborne server and the portable electronic device communicate operational data; and a ground communication system configured to receive the operational communications, the ground communication system comprising a ground network configured to communicate the operational communications across a communication link with the airborne server; and a ground peer application, configured to process the operational communications.

Example 2 includes the communication system of Example 1, wherein the airborne server further receives the operational communications from the portable electronic device and controls the transmission of the operational communications across the communication link.

Example 3 includes the communication system of any of Examples 1-2, wherein the portable electronic device controls communication of the operational communications across the communication link.

Example 4 includes the communication system of any of Examples 1-3 further comprising a communication transmitter for receiving operational communications from the portable electronic device and for transmitting the operational communications across the communications link.

Example 5 includes the communication system of any of Examples 1-4, wherein security measures prevent an unauthorized electronic device from accessing the avionic operational data and the operational communications.

Example 6 includes the communication system of any of Examples 1-5, wherein the external storage medium is accessed by a plurality of portable electronic devices for loading application configuration information into storage mediums on the plurality of portable electronic devices.

Example 7 includes the communication system of any of Examples 1-6, wherein the application configuration information stored in the external storage medium is generated using a configuration generation tool.

Example 8 includes the communication system of any of Examples 1-7, wherein the airborne server is a communication management unit.

Example 9 includes a portable electronic device, the device comprising a storage medium that stores application configuration information and an avionic operational data communications application, wherein the application configuration information is loaded into the storage medium from an external storage medium that stores the application configuration information defining an application configuration for the avionic operational data communications application; a network interface configured to receive and transmit the avionic operational data and operational communications; and a processing unit configured to process the received avionic operational data by executing the avionic operational data communications application as defined by the application configuration information.

Example 10 includes the portable electronic device of Example 9, wherein the network interface transmits and receives the avionic operational data and the operational communications from an airborne server.

Example 11 includes the portable electronic device of Example 10, wherein the network interface transmits the avionic operational data to the airborne server to relay the operational communications with a ground server.

Example 12 includes the portable electronic device of any of Examples 10-11, wherein the network interface communicates with the airborne server through a secure local network.

Example 13 includes the portable electronic device of any of Examples 9-12, wherein the network interface performs operational communications with a ground server.

Example 14 includes the portable electronic device of any of Examples 9-13, wherein the application configuration information stored in the external storage medium is generated using a configuration generation tool.

Example 15 includes a method for processing avionic operational data on a portable electronic device, the method comprising loading application configuration information into a storage medium on the portable electronic device from an external storage medium, the application configuration information defining an application configuration for the avionic operational data communications application; configuring an avionic operational data communications application stored in the storage medium on the portable electronic device according to the application configuration information stored in the storage medium; receiving avionic operational data from an airborne server; executing the avionic operational data communications application to process the avionic operational data, wherein the execution of the avionic operational data communications application produces operational communications from the avionic operational data according to the application configuration information stored in the storage medium; and communicating the operational communications with a ground peer.

Example 16 includes the method of Example 15, further comprising generating the application configuration information using a configuration generation tool.

Example 17 includes the method of Example 16, wherein communicating the avionic operational data with a ground peer comprises communicating with the ground peer through an airborne server, wherein the airborne server forms a communication link with the ground peer.

Example 18 includes the method of any of Examples 16-17, wherein communicating with a ground peer directly through a communication link.

Example 19 includes the method of any of Examples 15-18, further comprising preventing an unauthorized electronic device from accessing the avionic operational data and the operational communications.

Example 20 includes the method of any of Examples 15-19, further comprising generating the application configuration information with a configuration generation tool.

A number of embodiments of the invention defined by the following claims have been described. Nevertheless, it will be understood that various modifications to the described embodiments may be made without departing from the spirit and scope of the claimed invention. Accordingly, other embodiments are within the scope of the following claims.

What is claimed is:

1. A communication system, the system comprising:
 - an external storage medium storing operational application configuration information defining an application configuration for an avionic operational data communications application;
 - an aircraft communication system configured to perform operational communications, the aircraft communication system comprising:
 - a portable electronic device, wherein the portable electronic device is removable from the aircraft, the portable electronic device hosting the avionic operational data communications application that produces the

11

operational communications from avionic operational data, wherein the avionic operational data communications application is configured by the application configuration information stored on the portable electronic device, wherein the avionic operational data communications application controls operational communications, wherein operational communications include processed avionic operational data that is communicated between an aircraft and a fleet operations and control, wherein the application configuration information is loaded into a storage medium on the portable electronic device from the external storage medium; and

an aircraft server coupled to the portable electronic device, wherein the aircraft server and the portable electronic device communicate avionic operational data, wherein the aircraft server and the portable electronic device communicate independent of cockpit displays and instrumentation, wherein security measures prevent an unauthorized electronic device from accessing the avionic operational data and the operational communications; and

a ground communication system configured to receive the operational communications, the ground communication system comprising:

a ground network configured to communicate the operational communications across a communication link with the aircraft server; and

a ground peer application, configured to process the operational communications.

2. The communication system of claim 1, wherein the aircraft server further receives the operational communications from the portable electronic device and controls a transmission of the operational communications across the communication link.

3. The communication system of claim 1, wherein the portable electronic device controls communication of the operational communications across the communication link.

4. The communication system of claim 1 further comprising a communication transmitter for receiving operational communications from the portable electronic device and for transmitting the operational communications across the communications link.

5. The communication system of claim 1, wherein the external storage medium is accessed by a plurality of portable electronic devices for loading application configuration information into storage mediums on the plurality of portable electronic devices.

6. The communication system of claim 1, wherein the application configuration information stored in the external storage medium is generated using a configuration generation tool.

7. The communication system of claim 1, wherein the aircraft server is a communication management unit, wherein the portable electronic device is a personal electronic device.

8. A portable electronic device, the device comprising:

a storage medium that stores application configuration information and an avionic operational data communications application that produces operational communications from avionic operational data, wherein the application configuration information is loaded into the storage medium from an external storage medium that stores the application configuration information defining an application configuration for the avionic operational data communications application, wherein the avionic operational data communications application is

12

configured by the application configuration information stored in the storage medium, wherein the avionic operational data communications application controls operational communications, wherein operational communications include processed avionic operational data that is communicated between an aircraft and a fleet operations and control;

a network interface configured to receive and transmit the avionic operational data and operational communications with an aircraft server independent of cockpit displays and instrumentation; and

a processing unit configured to process the received avionic operational data by executing the avionic operational data communications application as defined by the application configuration information, wherein the portable electronic device is removable from an aircraft, wherein security measures prevent an unauthorized electronic device from accessing the avionic operational data and the operational communications.

9. The portable electronic device of claim 8, wherein the network interface transmits and receives the avionic operational data and the operational communications from the aircraft server.

10. The portable electronic device of claim 9, wherein the network interface transmits the avionic operational data to the aircraft server to relay the operational communications with a ground server.

11. The portable electronic device of claim 9, wherein the network interface communicates with the aircraft server through a secure local network.

12. The portable electronic device of claim 8, wherein the network interface performs operational communications with a ground server.

13. The portable electronic device of claim 8, wherein the application configuration information stored in the external storage medium is generated using a configuration generation tool.

14. A method for processing avionic operational data on a portable electronic device, the method comprising:

loading application configuration information into a storage medium on the portable electronic device from an external storage medium, the application configuration information defining an application configuration for an avionic operational data communications application, wherein the portable electronic device is removable from an aircraft, wherein the avionic operational data communications application controls operational communications, wherein operational communications include avionic operational data that is communicated between an aircraft and a fleet operations and control; configuring the avionic operational data communications application stored in the storage medium on the portable electronic device according to the application configuration information stored in the storage medium;

receiving avionic operational data, with the portable electronic device, from an aircraft server independent of cockpit displays and instrumentation;

executing the avionic operational data communications application to process the avionic operational data, wherein the execution of the avionic operational data communications application produces operational communications from the avionic operational data according to the application configuration information stored in the storage medium;

communicating the operational communications with a ground peer; and

preventing an unauthorized electronic device from accessing the avionic operational data and the operational communications.

15. The method of claim 14, further comprising generating the application configuration information using a configuration generation tool. 5

16. The method of claim 15, wherein communicating the operational communications with a ground peer comprises communicating with the ground peer through an aircraft server, wherein the aircraft server forms a communication link with the ground peer. 10

17. The method of claim 15, wherein communicating the operational communications with a ground peer comprises directly communicating with the ground peer through a communication link. 15

* * * * *