

US009568321B2

(12) **United States Patent**
Bharadwaj et al.

(10) **Patent No.:** **US 9,568,321 B2**
(45) **Date of Patent:** **Feb. 14, 2017**

(54) **SYSTEMS AND METHODS FOR DETERMINING INERTIAL NAVIGATION SYSTEM FAULTS**

FOREIGN PATENT DOCUMENTS

DE 102005018078 A1 10/2006
DE 102007012373 A1 9/2007

(Continued)

(75) Inventors: **Raj Mohan Bharadwaj**, Maple Grove, MN (US); **Vibhor L. Bageshwar**, Minneapolis, MN (US); **Kyusung Kim**, Plymouth, MN (US)

OTHER PUBLICATIONS

EP Search Report for EP 09167212.1 dated Oct. 16, 2009.
(Continued)

(73) Assignee: **HONEYWELL INTERNATIONAL INC.**, Morris Plains, NJ (US)

(*) Notice: Subject to any disclaimer, the term of this patent is extended or adjusted under 35 U.S.C. 154(b) by 880 days.

Primary Examiner — Gregory J Toatley
Assistant Examiner — Eman Alkafawi
(74) *Attorney, Agent, or Firm* — Ingrassia Fisher & Lorenz, P.C.

(21) Appl. No.: **13/029,204**

(22) Filed: **Feb. 17, 2011**

(65) **Prior Publication Data**

US 2011/0257927 A1 Oct. 20, 2011

Related U.S. Application Data

(60) Provisional application No. 61/325,697, filed on Apr. 19, 2010.

(51) **Int. Cl.**

G01C 9/00 (2006.01)

G06F 11/30 (2006.01)

(Continued)

(52) **U.S. Cl.**

CPC **G01C 21/165** (2013.01); **G01C 25/005** (2013.01)

(58) **Field of Classification Search**

CPC G01C 21/165; G01C 21/16; G01C 21/20
(Continued)

(56) **References Cited**

U.S. PATENT DOCUMENTS

5,451,964 A * 9/1995 Babu 342/357.31
5,719,764 A 2/1998 McClary

(Continued)

(57) **ABSTRACT**

An inertial navigation system (INS) includes a primary inertial navigation system (INS) unit configured to receive accelerometer measurements from an accelerometer and angular velocity measurements from a gyroscope. The primary INS unit is further configured to receive global navigation satellite system (GNSS) signals from a GNSS sensor and to determine a first set of kinematic state vectors based on the accelerometer measurements, the angular velocity measurements, and the GNSS signals. The INS further includes a secondary INS unit configured to receive the accelerometer measurements and the angular velocity measurements and to determine a second set of kinematic state vectors of the vehicle based on the accelerometer measurements and the angular velocity measurements. A health management system is configured to compare the first set of kinematic state vectors and the second set of kinematic state vectors to determine faults associated with the accelerometer or the gyroscope based on the comparison.

20 Claims, 3 Drawing Sheets

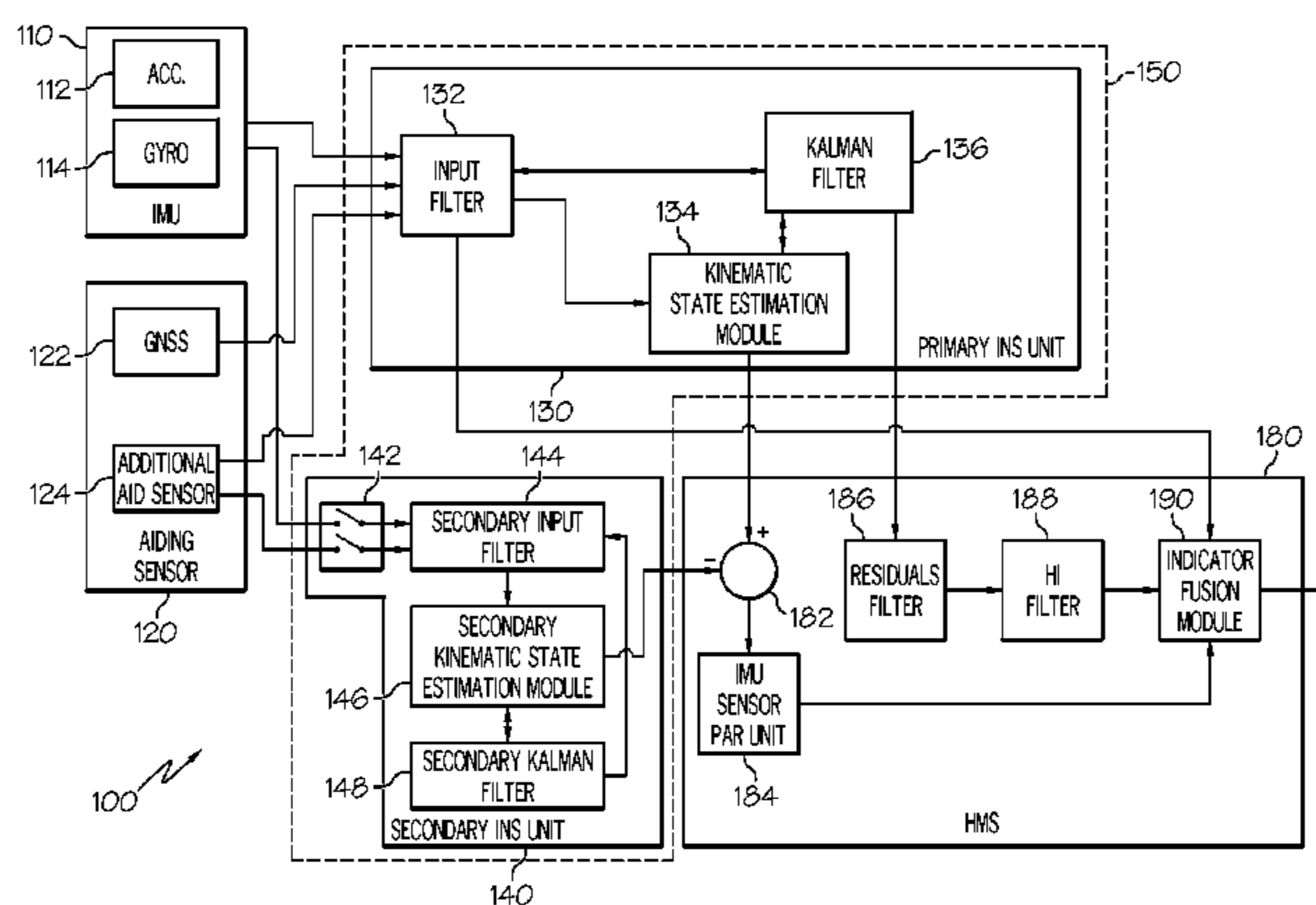

(51)	Int. Cl. <i>G01C 21/16</i> (2006.01) <i>G01C 25/00</i> (2006.01)	2007/0294116 A1 12/2007 Stephens et al. 2008/0151793 A1 6/2008 Wright 2008/0151841 A1 6/2008 Yi et al. 2008/0151889 A1 6/2008 Yi et al.
(58)	Field of Classification Search USPC 702/150, 183 See application file for complete search history.	2009/0157461 A1 6/2009 Wright et al. 2009/0192728 A1 7/2009 Wright et al. 2009/0216935 A1 8/2009 Flick 2009/0254278 A1 10/2009 Wang 2009/0326816 A1 12/2009 Park et al. 2010/0228408 A1* 9/2010 Ford G01C 21/165 701/16
(56)	References Cited U.S. PATENT DOCUMENTS	2011/0117903 A1* 5/2011 Bradley 455/418 2011/0304507 A1* 12/2011 Mujahed et al. 342/417
	5,906,655 A 5/1999 Fan 5,969,668 A 10/1999 Young, Jr. 6,018,698 A 1/2000 Nicosia et al. 6,167,347 A 12/2000 Lin 6,240,367 B1 5/2001 Lin 6,266,582 B1 7/2001 Bruckner 6,298,316 B1 10/2001 Diesel 6,408,245 B1* 6/2002 An et al. 701/472 6,430,488 B1 8/2002 Goldman et al. 6,449,559 B2 9/2002 Lin 6,611,842 B1 8/2003 Brown 6,654,685 B2 11/2003 McIntyre 6,665,600 B2 12/2003 Miller et al. 6,759,943 B2 7/2004 Lucy et al. 6,957,207 B2 10/2005 Sasaki 6,982,669 B2 1/2006 Coantiec et al. 7,177,738 B2 2/2007 Diaz 7,203,486 B2 4/2007 Patel 7,219,013 B1 5/2007 Young et al. 7,283,902 B2 10/2007 Heider et al. 7,328,104 B2 2/2008 Overstreet et al. 7,409,289 B2 8/2008 Coantiec et al. 7,447,590 B2 11/2008 Arethens 8,065,074 B1* 11/2011 Liccardo 701/480 8,290,744 B2* 10/2012 Brady et al. 702/183	FOREIGN PATENT DOCUMENTS EP 1837627 A2 9/2007 EP 1837627 A3 11/2007 JP 62128850 A 6/1987 JP 2005246997 A 9/2005 WO 2004074047 A1 9/2004 WO 2005069131 A1 7/2005
	2001/0020216 A1 9/2001 Lin 2002/0019701 A1 2/2002 Miller 2002/0073088 A1 6/2002 Beckmann et al. 2003/0023463 A1 1/2003 Dombroski et al. 2003/0080850 A1 5/2003 Kline 2003/0135327 A1* 7/2003 Levine et al. 701/220 2003/0149600 A1 8/2003 Williams 2004/0010358 A1 1/2004 Oesterling et al. 2004/0268217 A1 12/2004 Hughes et al. 2005/0125141 A1 6/2005 Bye 2005/0144048 A1 6/2005 Belanger et al. 2005/0261815 A1 11/2005 Cowelchuk et al. 2006/0038447 A1 2/2006 Bruelle-Drews 2006/0123081 A1 6/2006 Baudino et al. 2007/0219675 A1 9/2007 Uchida et al. 2007/0239494 A1 10/2007 Stephens et al.	OTHER PUBLICATIONS EP Office Action for EP 09167212.1 dated Nov. 6, 2009. EP Office Action for EP 09167212.1-1264 dated Apr. 20, 2011. EP Office Action for EP 09167212.1-1264 dated Nov. 30, 2012. USPTO Office Action for U.S. Appl. No. 12/186,885 dated Jul. 27, 2011. USPTO Final Office Action for U.S. Appl. No. 12/186,885 dated Jan. 5, 2012. Boys, R. Diagnostics and Prognostics for Military and Heavy Vehicles, 2004, pp. 1-13, Version 1.81, Dearborn Group, Inc. USPTO Office Action for U.S. Appl. No. 12/186,885; Notification date Jan. 5, 2012. JP Office Action for Application No. JP 2009-182723 dated Sep. 10, 2013. JP Office Action for Application No. JP 2009-182723 dated Jan. 8, 2014. EP search report, EP 11155074.5-1557/2378248, dated Mar. 24, 2014. CN Office Action for Application No. 201110050581.6 dated Jan. 12, 2015. EP Communication for Application No. 11155074.5-1557, dated Aug. 21, 2015. CN Office Action for Application No. 201110050581.6 dated Sep. 15, 2015. USPTO Notice of Allowance for U.S. Appl. No. 12/186,885 dated Dec. 3, 2015.

* cited by examiner

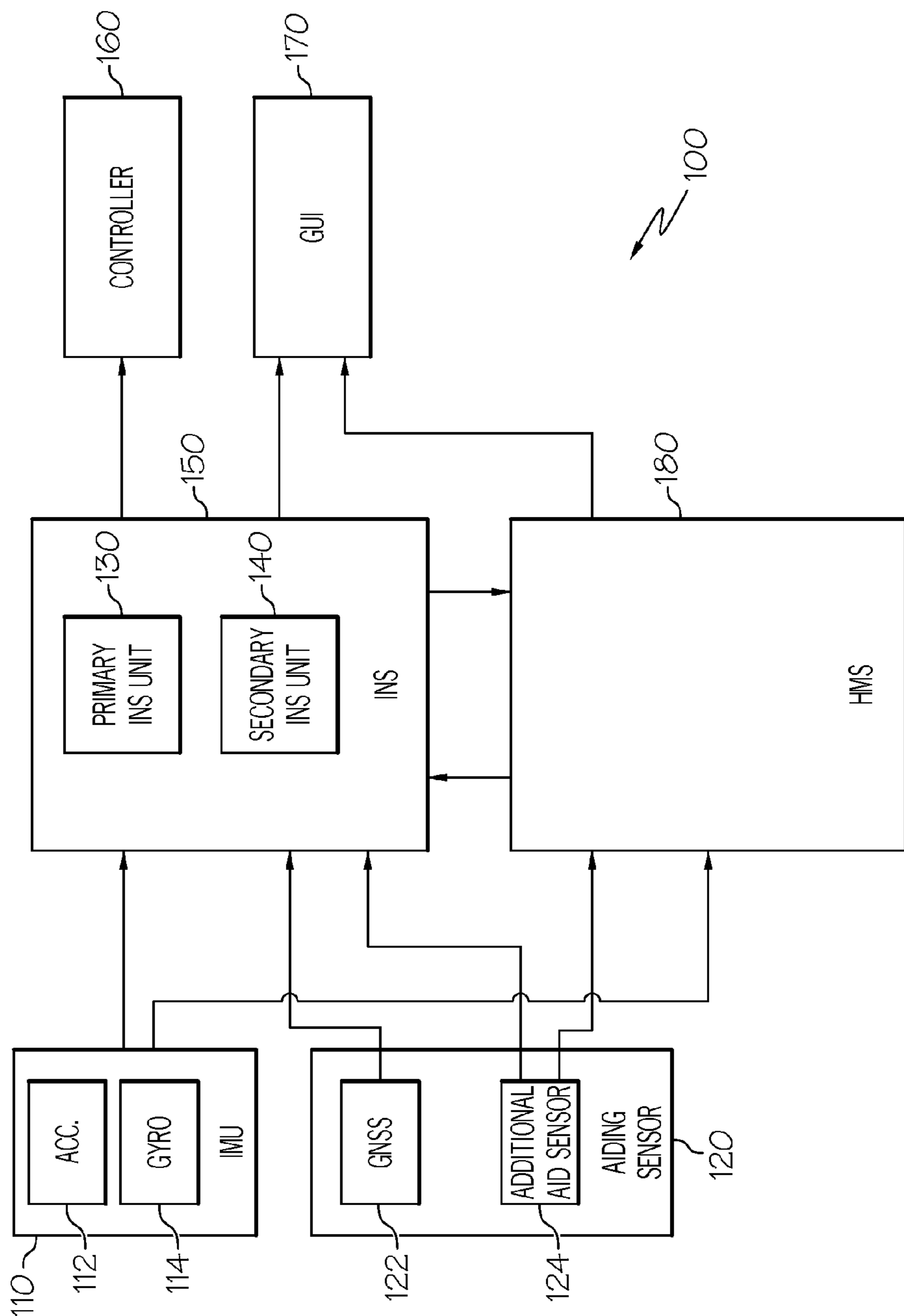

FIG. 1

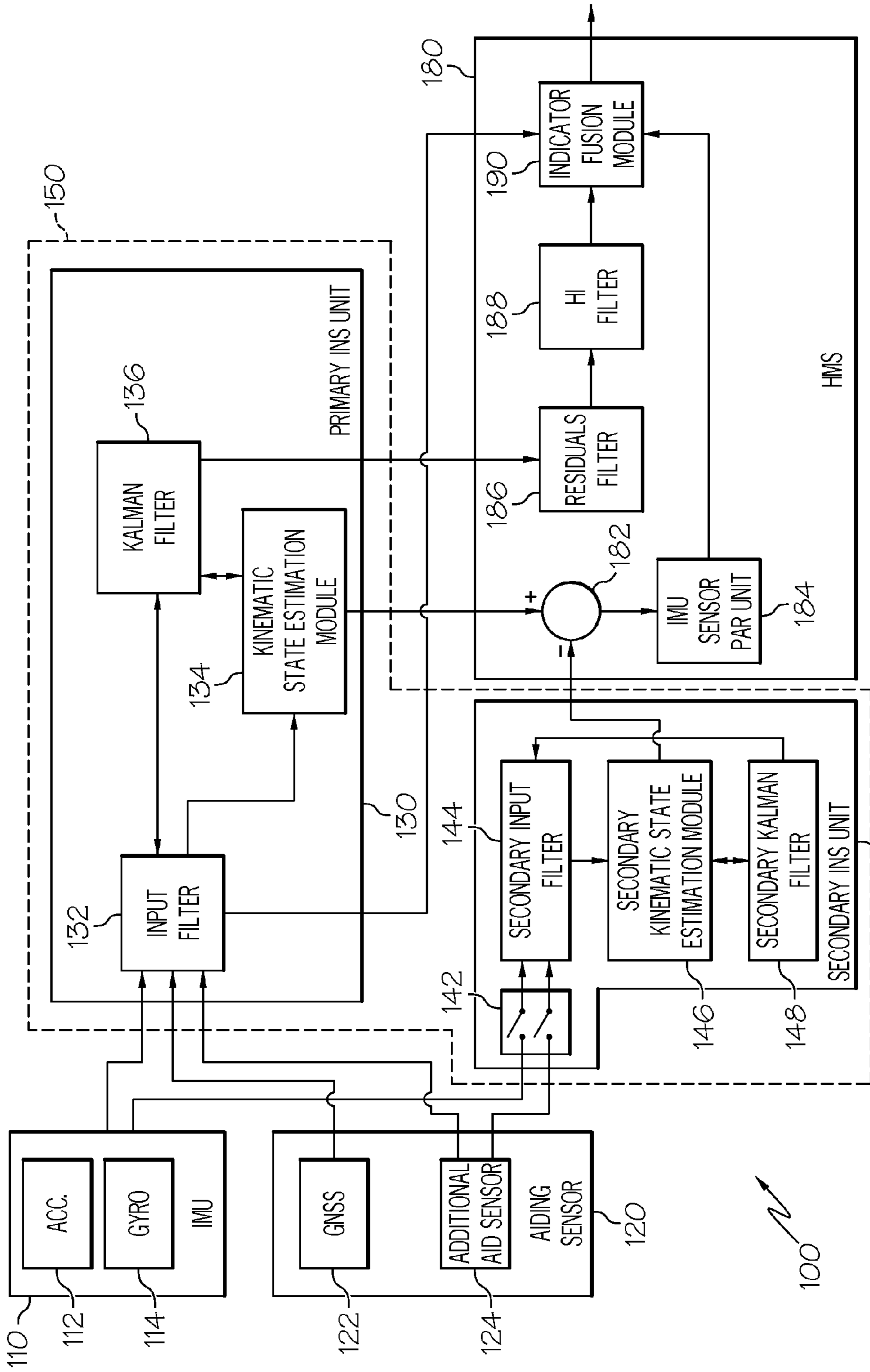

FIG. 2

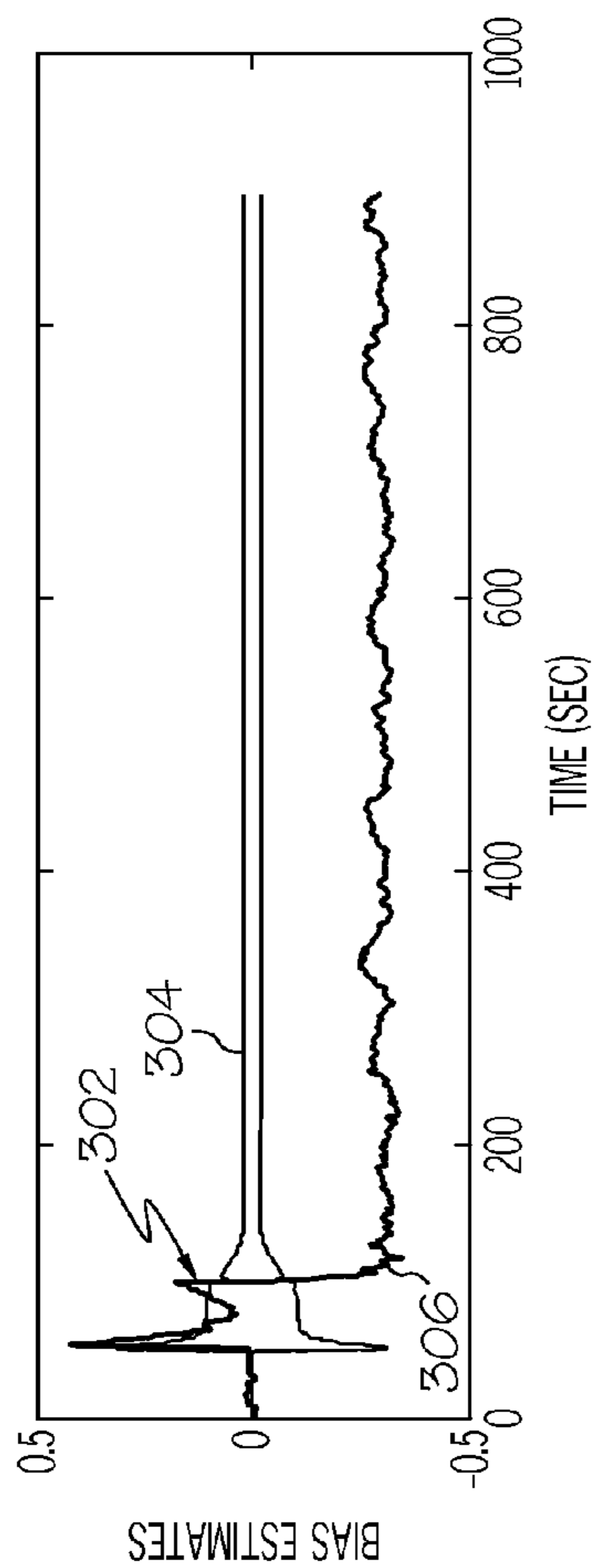

FIG. 3

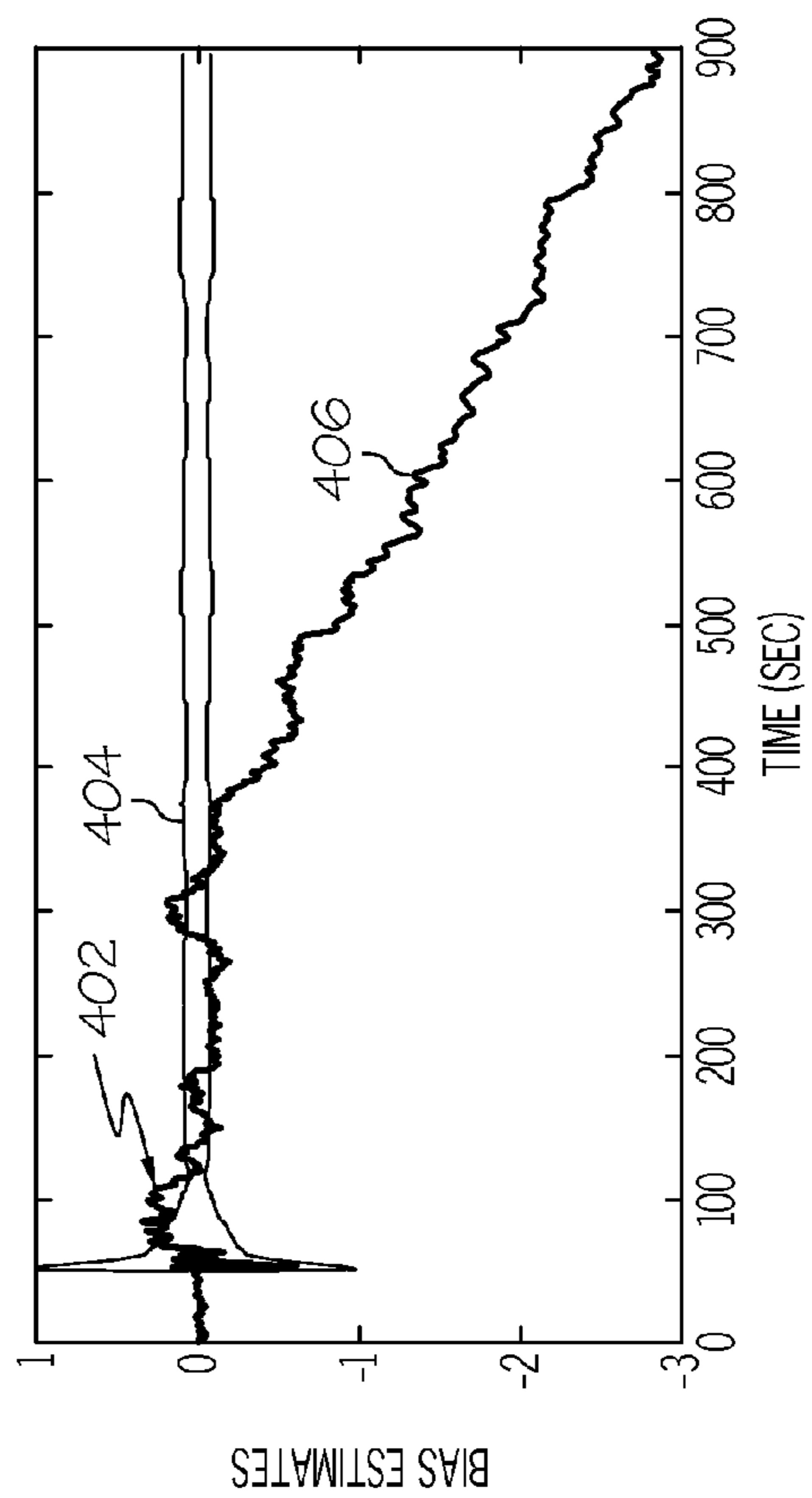

FIG. 4

1

**SYSTEMS AND METHODS FOR
DETERMINING INERTIAL NAVIGATION
SYSTEM FAULTS**

CROSS-REFERENCE TO RELATED
APPLICATION

This application claims the benefit of U.S. Provisional Application No. 61/325,697, filed Apr. 19, 2010, the disclosure of which is hereby incorporated by reference.

STATEMENT REGARDING FEDERALLY
SPONSORED RESEARCH OR DEVELOPMENT

This invention was made with Government support under Contract No. NNA08BA45C awarded by NASA. The Government has certain rights in this invention

TECHNICAL FIELD

The present invention generally relates to inertial navigation systems, and more particularly relates to health management systems and the detection of gyroscope and accelerometer faults in inertial navigation systems.

BACKGROUND

An inertial navigation system (INS) is a navigation aid that uses one or more inertial measurement units (IMUs) with sensors such as accelerometers and gyroscopes to continuously calculate position, velocity, and angular orientation of a moving object. An INS may be used on vehicles such as land vehicles, ships, aircraft, submarines, guided missiles, and spacecraft. The fidelity of the sensor measurements from the IMU is important to the overall navigation performance, and sensor faults or inaccurate sensor measurement models may cause a loss in navigation performance. Aiding sensors, such as global navigation satellite system (GNSS) sensors, have been used to correct navigation errors due to accelerometer bias and gyroscope bias, but the conventional approaches may not be satisfactory to correct navigation errors, particularly with respect to issues such as accelerometer and gyroscope measurement faults or accelerometer and gyroscope measurement model errors.

Accordingly, it is desirable to provide more accurate and robust INSs in the presence of IMU sensor measurement faults and IMU measurement model errors. Furthermore, other desirable features and characteristics of the present invention will become apparent from the subsequent detailed description of the invention and the appended claims, taken in conjunction with the accompanying drawings and this background of the invention.

BRIEF SUMMARY

In accordance with an exemplary embodiment, an inertial navigation system (INS) includes a primary inertial navigation system (INS) unit configured to receive accelerometer measurements from an accelerometer and angular velocity measurements from a gyroscope. The primary INS unit is further configured to receive global navigation satellite system (GNSS) signals from a GNSS sensor and to determine a first set of kinematic state vectors based on the accelerometer measurements, the angular velocity measurements, and the GNSS signals. The INS further includes a secondary INS unit configured to receive the accelerometer measurements and the angular velocity measurements and to

2

determine a second set of kinematic state vectors of the vehicle based on the accelerometer measurements and the angular velocity measurements. The INS further includes a health management system configured to compare the first set of kinematic state vectors and the second set of kinematic state vectors to determine faults associated with at least one of the accelerometer or the gyroscope based on the comparison.

In accordance with another exemplary embodiment, a vehicle system includes an inertial measurement unit (IMU) comprising an accelerometer configured to generate acceleration measurements and a gyroscope configured to generate angular velocity measurements; a global navigation satellite system (GNSS) configured to generate GNSS signals; a primary inertial navigation system (INS) unit configured to receive the accelerometer measurements, the angular velocity measurements, and the GNSS signals, the primary INS unit further configured to determine a first set of kinematic state vectors based on the accelerometer measurements, the angular velocity measurements, and the GNSS signals; a secondary INS unit configured to receive the accelerometer measurements and the angular velocity measurements and to determine a second set of kinematic state vectors of the vehicle based on the accelerometer measurements and the angular velocity measurements; and a health management system coupled to the primary INS unit and the secondary INS unit and configured to compare the first set of kinematic state vectors and the second set of kinematic state vectors to determine faults associated with at least one of the accelerometer or the gyroscope based on the comparison.

BRIEF DESCRIPTION OF THE DRAWINGS

The present invention will hereinafter be described in conjunction with the following drawing figures, wherein like numerals denote like elements, and

FIG. 1 is a functional block diagram of a vehicle system having an inertial navigation system (INS) in accordance with an exemplary embodiment;

FIG. 2 is a more detailed functional block diagram of portions of the vehicle system of FIG. 1 in accordance with an exemplary embodiment;

FIG. 3 is test data indicating accelerometer bias over time; and

FIG. 4 is test data indicating gyroscope bias over time.

DETAILED DESCRIPTION

The following detailed description is merely exemplary in nature and is not intended to limit the invention or the application and uses of the invention. As used herein, the word "exemplary" means "serving as an example, instance, or illustration." Thus, any embodiment described herein as "exemplary" is not necessarily to be construed as preferred or advantageous over other embodiments. All of the embodiments described herein are exemplary embodiments provided to enable persons skilled in the art to make or use the invention and not to limit the scope of the invention which is defined by the claims. Furthermore, there is no intention to be bound by any expressed or implied theory presented in the preceding technical field, background, brief summary, or the following detailed description.

Broadly, exemplary embodiments described herein are directed to a vehicle system with an inertial navigation system (INS) that includes a primary INS unit that calculates a first set of kinematic state vectors of the vehicle based on

signals from an inertial measurement unit (IMU), a global navigation satellite system (GNSS), and other aiding sensors. The INS may further include a secondary INS unit that calculates a second set of kinematic state vectors of the vehicle without considering the signals from the GNSS. A health management system identifies faults associated with the IMU based on a comparison between the kinematic state vectors from the primary INS unit and the second INS unit, as well as other vehicle information, as will now be described in greater detail with reference to FIGS. 1-4.

FIG. 1 is a functional block diagram of a vehicle system 100 in accordance with an exemplary embodiment. As shown, the vehicle system 100 may include an inertial measurement unit (IMU) 110, aiding sensors 120, an inertial navigation system (INS) 150, a health management system 180, a controller 160, and a graphical user interface (GUI) or display 170.

The vehicle system 100, and particularly the INS 150, may be used for navigation and control in any suitable type of vehicle (not shown), including land vehicles, aircraft, submarines, guided missiles and spacecraft. In general, and as discussed in greater detail below, the INS 100 includes a primary INS unit 130 and a secondary INS unit 140 that determine the position, velocity, and angular orientation of the associated vehicle based on signals from an inertial measurement unit (IMU) 110. As discussed below, the position, velocity, and angular orientation of the vehicle may also be based on signals from the group of aiding sensors 120, which may include a global navigation satellite system (GNSS) 122, such as a global positioning system (GPS), as well as additional aiding sensors 124.

As used herein, the position, velocity, and angular orientation of the vehicle may collectively be referred to as kinematic state vectors. The INS 150 provides the kinematic state vectors to the controller 160, which includes any of the functionalities necessary (for example, controlling flaps, engines, thrusters, rockets, and the like) for guidance, control, and stabilization of the vehicle along a desired trajectory. The kinematic state vectors from the INS 150 may also be appropriately formatted and displayed on the GUI 170 for viewing by an operator. As also discussed below, the calculation of the kinematic state vectors may be subject to errors associated with the measurements of the IMU 110. Although the primary INS unit 130 may incorporate some error correction, the health management system 180 is provided to more accurately detect and accommodate errors and faults associated with the IMU 110. The health management system 180 may be the central health management system of the vehicle or dedicated to the INS 150.

In general and as described in greater detail below, the primary INS unit 130 generates the kinematic state vectors based on signals from the IMU 110 and aiding sensors 120, including the GNSS 122, that are subsequently provided to the controller 160. The secondary INS unit 140 functions similarly to the primary INS unit 130 to generate an additional set of kinematic state vectors based on signals from the IMU 110 and, at times, on some of the additional aiding sensors 124. As used herein, the "first set" of kinematic state vectors refers to the kinematic state vectors generated by the primary INS unit 130 and the "second set" of kinematic state vectors refers to the kinematic state vectors generated by the secondary INS unit 140. Unlike the first set of kinematic state vectors, the second set of kinematic state vectors is generated without any consideration of the signals from the GNSS 122. The second set of kinematic state vectors is provided to the health management system 180 for improved error and fault detection, as discussed below. Although the

second INS unit 140 is illustrated as part of the INS 150, the secondary INS unit 140 may be considered separate from the INS 150 or part of the health management system 180.

Now turning to the diagram in FIG. 1 in greater detail, the IMU 110 includes sensors such as accelerometers 112 and rate gyroscopes 114. In one exemplary embodiment, the IMU 110 may be considered part of the INS 150. The IMU 110 typically contains three orthogonal accelerometers 112 and three orthogonal gyroscopes 114, although various types may be provided. The accelerometers 112 and gyroscopes 114, respectfully, provide measurements associated with the acceleration and angular velocity of the vehicle to the INS 150. The INS 150 determines the kinematic state vector of the vehicle in two reference frames based on the measurements provided by the IMU 110. The two reference frames typically include a fixed body vehicle frame and a navigation frame with known orientation.

Initially, the primary INS unit 130 integrates angular velocity measurements from the gyroscopes-114 to compute the orientation of the vehicle body frame relative to the navigation frame. In one exemplary embodiment, the accelerometers 112 measure specific force, which is then subject to gravity and accelerometer bias compensation by the primary INS unit 130 to yield vehicle acceleration. The primary INS unit 130 further resolves the compensated acceleration in the navigation frame and integrates the compensated vehicle acceleration to result in a velocity vector resolved in the navigation frame. Integrating the compensated vehicle acceleration twice results in a position vector resolved in the navigation frame. Of course, other mechanisms for calculating the position, velocity, and angular orientation of the vehicle may be provided.

However, as introduced above, the IMU measurements may have associated errors, such as bias, scale factor, non-orthogonality, and wide band noise. If uncorrected, these errors may result in potentially unbounded errors in the estimates of the kinematic state vectors. For example, a constant error in the acceleration measurement will become a linear velocity error as the primary INS unit 130 integrates the acceleration measurement to determine velocity. Continuing the example, a constant error in the acceleration measurement will become a parabolic position error as the primary INS unit 130 twice integrates the acceleration measurement to determine position. Similarly, a constant error in the angular velocity will become a linear angular orientation error as the primary INS unit 130 integrates the angular velocity to determine angular orientation. The error in the angular velocity further affects the velocity and position calculations since the angular orientation is used to resolve the velocity and position in the navigation frame. Non-linear or random errors further exacerbate this issue. As such, the primary INS unit 130 attempts to correct errors when determining the kinematic state vector. In some exemplary embodiments, it is generally preferred that the errors are removed prior to integrating the measurements, since there is some randomness and estimation involved in the error itself.

There are several types of faults that may result in errors in the kinematic state vectors. Such errors may include, for example, IMU sensor measurement faults at a particular time (for example, the measurement should have been 1 m/s² but the measurement was 100 m/s²); or mismatches between the IMU measurements and the IMU sensor measurement model (for example, due to parameter errors in the model occurring over time or modeling error such as missing a parameter or using an incorrect parameter). These faults may be an indication of bias, which may include bias

change or bias drift and refer to an error in the model or the sensor itself. In one exemplary embodiment, the bias change may be a relatively slow time-varying error or the bias change may be a relatively fast time-varying error, although any suitable characterization techniques may be provided. In general, bias change is the most common fault of interest with respect to the accelerometers **112** of the IMU **110**, and bias drift is the most common fault with respect to the gyroscopes **114** of the IMU **110**.

As one approach to correct or accommodate these errors, the primary INS unit **130** further receives aiding sensor measurements that include GNSS measurements from the GNSS **122** and additional aiding sensor measurements from the additional aiding sensors **124**, as noted above. In general, the GNSS **122** may include a receiver that receives satellite signals to determine position and velocity, for example. The additional aiding sensors **124** may include, for example, various combinations of a magnetometer, a barometer, an odometer, or any other sensor. The measurements from the additional aiding sensors **124** and GNSS **122** are independent of the IMU sensor measurements and can be used to periodically estimate the kinematic state vector errors and reset the IMU-based estimates of the kinematic state vectors to thus produce improved estimates of the kinematic state vectors. For example, the GNSS **122** may provide position and velocity measurements that may be compared to the position and velocity values initially estimated by the primary INS unit **130** based on the measurements from the IMU **110**. This comparison provides a basis for estimating the errors in the position and velocity values generated by the primary INS **130**. The corresponding correction of these estimates prevents any errors from the IMU-based estimates from growing without bound. As another example, a magnetometer of the additional aiding sensors **124** may be used to compute heading angle either in combination with the heading angle computed from GNSS velocity measurements or by itself. Despite these signals from the aiding sensors **120**, some errors may remain, as discussed below.

In accordance with exemplary embodiments, the vehicle system **100** further considers the errors remaining in the kinematic state vectors generated by the primary INS unit **130** to generally provide more accurate kinematic state calculations. Although the GNSS **122** may be used to remove some errors from the kinematic state vector calculations in the primary INS unit **130** by providing position and velocity measurements, the GNSS **122**, in some embodiments, operates at a much lower frequency than the IMU **110**, and the primary INS unit **130** generally must generate kinematic state vectors more often than it receives information from the GNSS **122**. As such, if the GNSS **122** is the sole source of error correction, some errors in the kinematic state vectors will remain, particularly errors such as accelerometer bias change resulting from faults in the accelerometer **112** and gyroscope bias drift resulting from faults in the gyroscopes **114**.

To accommodate and detect these errors, the health management system **180** may be initialized to receive and process the first set of kinetic state vectors generated by the primary INS unit **130** and the second set of kinematic state vectors generated by the secondary INS unit **140**. As stated above, the secondary INS unit **140** generates position, velocity, and angular orientation in a manner similar to the primary INS unit **130**, except that the measurements from the GNSS **122** are not considered. For example, the secondary INS unit **140** may use dynamic models, IMU sensor measurement models, aiding sensor measurement models, and filters, like the primary INS unit **130**, but does not

modify, correct, or calibrate the resulting kinematic state vectors based on the measurements from the GNSS **122**. As a result, the uncompensated IMU sensor measurement errors are integrated with the IMU sensor measurements when the secondary INS unit **140** calculates the kinematic state vectors, thereby enabling the errors in the estimated kinematic state vectors to grow without bound. Measurements from the additional aiding sensors **124** may or may not be used to calculate the kinematic state vectors of the secondary INS unit **140**. In effect, the secondary INS unit **140** enables such errors to grow as necessary or desired, without correction from the GNSS **122**, such that any errors associated with the IMU **110** may be more easily identified.

Accordingly, the health management system **180** then identifies faults within the IMU **110** by comparing two sets of kinetic state vectors respectively generated by the primary INS unit **130** and the secondary INS unit **140**. The resulting difference corresponds to errors attributed to measurement errors or bias in the IMU **110**. The faults may be stored for later use or displayed to an operator on the GUI **170**. Further details of the primary INS unit **130**, secondary INS unit **140**, and health management system **180** will now be described with reference to FIG. **2**.

FIG. **2** is a more detailed functional block diagram of portions of the vehicle system **100** of FIG. **1** in accordance with an exemplary embodiment. FIG. **2** generally corresponds to the vehicle system **100** discussed above, and particularly illustrates the error correction mechanisms of the primary INS unit **130**, the secondary INS unit **140**, and the health management system **180** in greater detail.

As shown in FIG. **2**, the primary INS unit **130** includes an input filter **132**, a kinematic state vector estimation module **134**, and a Kalman filter **136**. In this exemplary embodiment, measurements from the IMU **110**, which includes the accelerometers **112** and the gyroscopes **114**, the GNSS unit **122**, and the additional aiding sensors **124** are provided to the input filter **132** of the primary INS unit **130**. The input filter **132** generally functions to reject measurements that are completely outside of a possible range. For example, the input filter **132** may calculate the input residuals, e.g., the difference between the sensor measurements and the current estimate of the kinematic state vector, and use statistical tests to determine which measurements should be rejected. These rejected measurements from the input filter **132** may be provided to the health management system **180** as first health indicators.

The accepted measurements from the input filter **132** are provided to the kinematic state vector estimation module **134**, which includes a number of models that initially estimate the kinematic state vectors based on the measurements from the IMU **110**. The models may include dynamic models, measurement models, and sensor measurements models for generating a stochastic system that uses the sensor measurements to compute estimates of the kinematic state vectors. As described above, the kinematic state vector estimation module **134** is particularly configured to evaluate the measurements from the IMU **110** and to produce acceleration values, which are then integrated a first time to produce velocity values and a second time to produce position values, each of which are may be resolved in the desired reference frame.

The kinematic state vector estimation module **134** provides the initial kinematic state vectors to the Kalman filter **136**, which in turn, blends the kinematic state vectors with the aiding sensor measurements to produce bounded estimates of posterior (or compensated) kinematic state vectors. In general, the Kalman filter **136** uses measurements from

the GNSS **122** and additional aiding sensors **124**, which are independent of the IMU **110**, to correct the measurements from the IMU **110** to provide more accurate kinematic state vectors. The Kalman filter **136** may include a bias estimation module and an a-priori bias estimation module. The bias estimation module may include a number of models that estimate the measurement bias of the IMU **110** with, for example, measurements from the aiding sensors **120** (e.g., the GNSS **122** and the additional aiding sensors **124**), and may use some a-priori bias statistics from the a-priori bias estimation module, for example, to account for known biases. In one exemplary embodiment, the a-priori bias estimation model is a dynamic model of the bias and uses the IMU measurements to propagate the statistics of the IMU bias forward to provide a-priori bias statistics, and the bias estimation module uses combinations of the aiding sensor measurements, a-priori kinematic state vector, and a-priori bias statistics to update the a-priori bias statistics as posterior bias statistics.

The aiding sensor measurements may be used to correct the effect of the forward integration of any IMU measurement biases, as discussed above. In general, the kinematic state vectors are predicted using the dynamic models, the IMU sensor measurements, and IMU measurement models; and the aiding sensor measurements are used in aiding sensor measurement models to correct the IMU based estimates of position, velocity, and angular orientation. As an example, information generated by the dynamic models of the kinematic state vector estimation module **134** and/or Kalman filter **136** may include the time evolution of the kinematic state vectors, the kinematic state error vectors, and the covariance matrix of the kinematic state vectors. Sensor measurements models of the kinematic state vector estimation module **134** and/or Kalman filter **136** may indicate the time evolution of the sensor measurement errors or the relationship between sensor measurements, sensor measurement errors, kinematic state vectors, and kinematic state error vectors. The IMU sensor measurement models may further include parameters that model the performance characteristics of the sensors including sensor measurement errors or biases. The estimates of the parameters of these sensor models may attempt to compensate for a number of factors such as model matching errors, calibration errors, temperature variation, vehicle vibration, etc. In general, the Kalman filter **136** uses the models and all sensor measurements in an iterative prediction correction approach.

In one exemplary embodiment, the Kalman filter **136** produces the posterior primary kinematic state vectors and estimated errors as follows. As noted above, the bias estimation module may provide at least some error estimates, including residuals between observed values and estimated values. From the residuals and associated statistical properties, a scalar test statistic with chi-square distribution and n degrees of freedom is created, where n is the number of measurements used for creating the test statistic. This statistic is later compared with a predefined threshold to identify errors. Using the chi-square distribution allows a group of measurements to be correlated to each other, thereby improving the chances to successfully detect and calculate an error and the corresponding bias for accelerometer and gyroscope measurements. A Gauss-Markov (GM) process may be used to model a time varying bias ($\dot{b}_{GM}(t)$), for example:

$$\tilde{y} = y + \delta y + w$$

$$\delta y = b_{const} + b_{GM}$$

$$\dot{b}_{GM}(t) = \frac{-1}{\tau} b_{GM}(t) + w_{GM}$$

where y is the accelerometer or gyroscope measurement; δy is the accelerometer or gyroscope bias; w is a zero mean, Gaussian white noise process; w_{GM} is zero mean, Gaussian white noises that drive the GM process; and τ is the time constant of the GM process.

The accelerometer bias model may be simplified by estimating the constant bias at initialization. Then, the time-varying bias and the white noise components correspond to the remaining error sources of the IMU **110**. Upon calculation of the errors and associated corrections, the first set of kinematic state vectors may be provided to the controller **160** (FIG. 1) for navigation and control of the vehicle (not shown). As noted above, the primary INS unit **130** may additionally provide the kinetic state vectors and any error or fault information to the health management system **180** and/or the GUI **170**. The errors gathered in the Kalman filter **136** may particularly be provided to the health management system **180** as residuals or second health indicators.

As noted above, the second INS unit **140** may be used to provide a second set of kinematic state vectors that are subsequently used by the health management system **180** for more accurate kinematic state vectors and bias estimations. Particularly, the secondary INS unit **140** may be initialized using a switch **142**. The sampling rate of the switch **142** determines the frequency and duration of kinematic state vector estimation by the secondary INS unit **140**. Control of the switch **142** may be based on statistics associated with the kinematic state vectors of the first INS unit **130** and initiated by the health management system **180** or at a predetermined sampling rate or interval. When the switch **142** is turned off, the secondary INS unit **140** is typically reset in anticipation of the next iteration.

As shown in FIG. 2, the secondary INS unit **140** includes a secondary input filter **144**, a secondary kinematic state vector estimation module **146**, and a secondary Kalman filter **148**. In general, the secondary INS unit **140** is similar to the primary INS unit **130** except that any errors in the kinematic state vector estimation are allowed to grow without bound, e.g., without correction from the GNSS **122**.

Accordingly, upon initialization of the switch **142**, the secondary input filter **144** receives the measurements from the IMU **110** and, optionally, the additional aiding sensors **124**. Like the input filter **132**, the secondary input filter **144** generally functions to reject measurements that are completely outside of a possible range. The accepted measurements are provided to the secondary kinematic state vector estimation module **134**, which includes a number of models that initially estimate the secondary kinematic state vectors based on the measurements from the IMU **110**. The secondary kinematic state vector estimation module **134** provides the initial second set of kinematic state vectors to the secondary Kalman filter **148**, which in turn further filters the kinematic state vectors to produce a second set of kinematic state vectors (e.g., a posterior second set of kinematic state vectors). As noted above, the secondary kinematic state vector estimation module **146** and secondary Kalman filter **148** generate the second set of (or uncorrected) kinematic state vectors without considering the GNSS measurements

from the GNSS 122. The secondary INS unit 140 may calculate the second set of kinematic state vectors either with or without using measurements from the additional aiding sensors 124. Typically, the secondary INS unit 140 uses a subset of the measurements from the additional aiding sensors 124. In one exemplary embodiment, the primary INS unit 130 and the secondary INS unit 140 may use the same IMU sensor measurement models.

As in the primary INS unit 130, the Kalman filter 148 may include a bias estimation module and an a-priori basis estimation module. However, in the secondary INS unit, the bias estimation module may include a number of models that estimate the measurement bias of the IMU 110 without, for example, measurements from the GNSS unit 122. As described below, the Kalman filter 148 generates kinematic state vectors and error estimates, including Kalman filter residuals that may be provided to the input filter 144 for generating input residuals. The second set of kinematic state vectors from the secondary INS unit 140 are provided to the health management system 180 for subsequent fault detection.

The health management system 180 generally includes a comparator 182, an IMU sensor parameter unit 184, a residuals filtering unit 186, a health indicator module 188, and an indicator fusion module 190. As described above, the health management system 180 receives health indicators from the input filter 132 of the first INS unit 130 as first health indicators at the indicator fusion module 188. The health management system 180 further receives the innovations or residuals from the Kalman filter 136 of the primary INS unit 130 as second health indicators at the residuals filtering unit 186. The residuals filtering unit 186 may include a jump filtering unit and provides the second health indicators to the health indicator module 188. These health indicators are processed by the health indicator module 188 to estimate the nature of the errors, such as the magnitude and direction of drift, bias, variances, etc. For example, the health indicators module 188 may compare the health indicators to an expected probability density function to determine faults. These estimates are then provided to the indicator fusion block 190. The indicator fusion module 190 is discussed in greater detail below.

As stated above, the health management system 180 further receives the second set of kinematic state vectors from the secondary INS unit 140 as well as the first set of kinematic state vectors from the primary INS unit 130. Particularly, the comparator 182 of the health management system 180 compares the two sets of kinematic state vectors to determine the differences between the kinematic state vectors. The resulting differences are provided to the IMU sensor parameter estimation unit 184, which uses IMU measurement models to estimate the IMU sensor parameters and various types of errors or characteristics of the IMU measurements. In one exemplary embodiment, the estimated IMU sensor parameters are compared to the current set of IMU sensor parameters to identify IMU sensor modeling errors. The resulting estimated parameters are provided to the indicator fusion module 190 as third health indicators. The third health indicators generally correspond to errors attributed to measurement errors in the IMU 110, which may also correspond to drift in the IMU 110.

As such, the indicator fusion module 190 may directly or indirectly receive health indicators from the input filter 132 of the primary INS unit 130, the Kalman filter 136 of the primary INS unit 130, and the secondary INS unit 140. The indicator fusion module 190 may fuse the various indicators to confirm, isolate and quantify faults using logical, voting

or probabilistic reasoning to fuse the available indicators. In one exemplary embodiment, the fault may be detected and isolated based on a single fault assumption (presence of single fault in either an accelerometer or gyroscope based on a single type of health indicator) or based on a combination of fault indications. In another exemplary embodiment, the fault is identified, isolated and quantified, and then the associated correction is fed back to the primary INS unit 130. If the fault is an IMU measurement model error, then the fault is fed back to the secondary INS unit 140 to update the IMU measurement models in the secondary kinematic state vector estimation module 146 and/or secondary Kalman filter 148.

As noted above, the indicator fusion module 190 may identify a based on a single type of health indicator, such as the differences between the kinematic state vectors, or a combination of the health indicators. For example, the indicator fusion module 190 may detect a statistical property shift, e.g., a change in mean and/or distribution density function, or stochastically estimate the fault parameters based on any number of techniques. These statistical comparisons may be used to separate the various types of sensor faults discussed above. For example, the delta comparison of the comparator 182 may be a comparison of the mean (or first moment of a distribution) and used to determine a change in the standard deviation of a Gauss Markov process that governs the IMU bias. Higher order statistics of the comparison may be used to estimate additional faults of the IMU sensors. In general, however, any statistical technique may be used to identify the faults.

In one exemplary embodiment, the indicator fusion module 190 may also separate out accelerometer bias from the gyroscope bias. For example, the errors in measurements from the gyroscopes 114 may be considered in the orientation angles. The combination of accelerometer errors and gyroscope errors may be considered in the position and velocity so that if the impact of gyroscope errors is removed from the position and velocity, such that only the accelerometer errors remain. The vehicle trajectory may also assist in identifying if the errors in position and velocity are due to the accelerometer errors or the gyroscope errors.

The indicator fusion module 190 (or other component) may include model that govern how the bias impacts the accelerometer and gyroscope measurements. As noted above, the second set of kinematic state vectors include some bias that are allowed to grow without bound during operation of the secondary INS unit 140. Based on this second set, such models determine how the uncompensated bias affects the position, velocity, and angular orientation values.

For example, in one exemplary embodiment, the gyroscope bias may be determined by comparing the angular orientation computed as part of the first and second sets of kinematic state vectors. The error growth of the difference between the two estimated angular orientations may be directly equated to the parameters of the selected gyroscope measurement model with a statistical approach, such as least squares. Upon estimation the parameters of the gyroscope measurement model (e.g., primarily the bias), the parameters of the accelerometer measurement model using the position and velocity differences between the first and second sets of kinematic state vectors. The gyroscope bias may be removed to identify the remaining acceleration bias. The indicator fusion module 190 may then use these estimated parameters of the acceleration and gyroscope biases to identify IMU sensor faults using any suitable statistical tests. Of course,

11

the examples discussed herein for determining the acceleration and gyroscope bias are merely exemplary and other techniques may be used.

Accordingly, the indicator fusion module **190** may determine at least two different failure modes of the IMU **110**. The failure modes may include 1) accelerometer failure resulting in a bias change, and 2) gyroscope bias and drift. These issues are particularly important in an INS **100** with a single set of three-axis accelerometers **114**. Even in a highly redundant system, these exemplary embodiments of fault detection and isolation may provide additional health information to the redundancy management system.

In one exemplary embodiment, the accelerometer bias fault determinations use the bias estimate along with the multiple of 1-sigma confidence level generated using the a-priori IMU sensor noise variance. The health management system **180** may produce an alarm when the bias estimate exceeds a user-defined multiple of the 1- σ bias estimate bound. As one example, isolation may be performed by attributing the persistent alarm on the accelerometer bias estimates to the faulty accelerometer.

FIGS. **3** and **4** illustrate test data indicating accelerometer bias and gyroscope bias, respectively, over time. As described above, a fault may be identified by comparing estimates to predetermined fault thresholds. FIG. **3** particularly illustrates the accelerometer bias estimates **302**, the 1- σ estimation errors (or bounded limits) **304** of the accelerometer bias estimates **302**, and the alarm trigger **306** indicating accelerometer bias change. By allowing the effect of the accelerometer bias estimates **302** on the kinematic state vector to accumulate over time with the secondary INS unit **140**, the health management system **180** may more easily identify the accelerometer bias at the alarm trigger **306**.

FIG. **4** particularly illustrates the gyroscope bias estimates **402**, the 1- σ estimation errors (or bounded limits) **404** of the gyroscope bias estimates **402**, and the alarm trigger **406** indicating gyroscope bias change. By allowing the effect of the gyroscope bias estimates **402** on the kinematic state vector to accumulate over time with the secondary INS unit **140**, the health management system **180** may more easily identify the gyroscope bias at the alarm trigger **406**.

Accordingly, exemplary embodiments discussed herein include update, correct, or modify errors associated with IMU measurements. Exemplary embodiments may identify the following: an accelerometer fault, gyroscope fault, an accelerometer measurement fault, a gyroscope measurement fault; the axis of the accelerometer measurement fault; the axis of the rate gyro measurement fault; a fault in the IMU sensor measurement model, an accelerometer parameter fault; a gyroscope parameter fault; the axis of the accelerometer parameter fault; and the axis of the gyroscope parameter fault.

It should be observed that the disclosed embodiments reside primarily in combinations of device components and process sets. Various aspects of the embodiments, such as units and other function blocks, modules, circuits, and algorithm steps described herein may be implemented as electronic hardware, computer software, or combinations of both. The various illustrative logical blocks, modules, and circuits described in connection with the embodiments disclosed herein may be implemented or performed with a general purpose processor, a digital signal processor (DSP), an application specific integrated circuit (ASIC), a field programmable gate array (FPGA) or other programmable logic device, discrete gate or transistor logic, discrete hardware components, or any combination thereof designed to perform the functions described herein. A software module

12

may reside in RAM memory, flash memory, ROM memory, EPROM memory, EEPROM memory, registers, hard disk, a removable disk, a CD-ROM, or any other form of storage medium known in the art. An exemplary storage medium is coupled to the processor such the processor can read information from, and write information to, the storage medium. In the alternative, the storage medium may be integral to the processor. The processor and the storage medium may reside in an ASIC.

While at least one exemplary embodiment has been presented in the foregoing detailed description of the invention, it should be appreciated that a vast number of variations exist. It should also be appreciated that the exemplary embodiment or exemplary embodiments are only examples, and are not intended to limit the scope, applicability, or configuration of the invention in any way. Rather, the foregoing detailed description will provide those skilled in the art with a convenient road map for implementing an exemplary embodiment of the invention. It being understood that various changes may be made in the function and arrangement of elements described in an exemplary embodiment without departing from the scope of the invention as set forth in the appended claims.

What is claimed is:

1. An inertial navigation system (INS), comprising:
 - a primary inertial navigation system (INS) unit configured to receive first accelerometer measurements from a first accelerometer and first angular velocity measurements from a first gyroscope,
 - the primary INS unit further configured to receive global navigation satellite system (GNSS) signals from a GNSS sensor and to determine a first set of kinematic state vectors based on the first accelerometer measurements, the first angular velocity measurements, and the GNSS signals;
 - a secondary INS unit configured to receive the first accelerometer measurements and the first angular velocity measurements and to determine a second set of kinematic state vectors of the vehicle based on the first accelerometer measurements and the first angular velocity measurements; and
 - a health management system configured to compare the first set of kinematic state vectors and the second set of kinematic state vectors to determine faults associated with at least one of the first accelerometer or the first gyroscope based on the comparison.
2. The INS of claim 1, wherein the primary INS unit includes primary accelerometer and gyroscope measurement models for determining the first set of kinematic state vectors and the secondary INS unit includes secondary accelerometer and gyroscope measurement models for determining the second set of kinematic state vectors.
3. The INS of claim 2, wherein the primary accelerometer and gyroscope measurement models and the secondary accelerometer and gyroscope measurement models are the same.
4. The INS of claim 2, wherein the health management system is further configured to determine faults associated with the primary accelerometer and gyroscope measurement models or the secondary accelerometer and gyroscope measurement models.
5. The INS of claim 1, wherein the health management system is configured to generate the second set of kinematic state vectors with errors due to accelerometer bias.
6. The INS of claim 1, wherein the health management system is configured to generate the second set of kinematic state vectors with errors due to gyroscope bias.

13

7. The INS of claim 1, further comprising a switch coupled to the secondary INS unit and configured to initialize the secondary INS unit based on a predetermined sampling rate or statistics associated with the first set of kinematic state vectors.

8. The INS of claim 1, wherein the primary INS unit is further configured to receive additional sensor measurements from at least one additional aiding sensor and to additionally determine the first set of kinematic state vectors based on the additional sensor measurements.

9. The INS of claim 1, wherein the secondary INS unit is configured to determine the second set of kinematic state vectors independently of the GNSS signals.

10. The INS of claim 1, wherein the comparison between the first set of kinematic state vectors and the second set of kinematic state vectors generates a first set of health indicators, and wherein the primary INS unit includes a first Kalman filter configured to receive the GNSS signals and to determine a second set of health indicators associated with the first set of kinematic state vectors.

11. The INS of claim 10, wherein primary INS unit includes an input filter configured to produce a third set of health indicators associated with the first set of kinematic state vectors, and wherein the health management system includes a fusion module configured to determine the faults based on the first set of health indicators, the second set of health indicators, and the third set of health indicators.

12. A vehicle system, comprising:

an inertial measurement unit (IMU) comprising a first accelerometer configured to generate first acceleration measurements and a first gyroscope configured to generate first angular velocity measurements;

a global navigation satellite system (GNSS) configured to generate GNSS signals;

a primary inertial navigation system (INS) unit configured to receive the first accelerometer measurements, the first angular velocity measurements, and the GNSS signals, the primary INS unit further configured to determine a first set of kinematic state vectors based on the first accelerometer measurements, the first angular velocity measurements, and the GNSS signals;

a secondary INS unit configured to receive the first accelerometer measurements and the first angular velocity measurements and to determine a second set of kinematic state vectors of the vehicle based on the first accelerometer measurements and the first angular velocity measurements, wherein the secondary INS unit is configured to determine the second set of kinematic state vectors independently of the GNSS signals; and

a health management system coupled to the primary INS unit and the secondary INS unit and configured to compare the first set of kinematic state vectors and the second set of kinematic state vectors to determine faults associated with at least one of the first accelerometer or the first gyroscope based on the comparison,

wherein the primary INS unit includes primary accelerometer and gyroscope measurement models for determining the first set of kinematic state vectors and the secondary INS unit includes secondary accelerometer and gyroscope measurement models for determining the second set of kinematic state vectors,

wherein the primary accelerometer and gyroscope measurement models and the secondary accelerometer and gyroscope measurement models are the same, and

wherein the health management system is further configured to determine faults associated with the primary

14

accelerometer and gyroscope measurement models or the secondary accelerometer and gyroscope measurement models.

13. The vehicle system of claim 12, wherein the health management system is configured to generate the second set of kinematic state vectors with errors due to accelerometer bias.

14. The vehicle system of claim 12, wherein the health management system is configured to generate the second set of kinematic state vectors with errors due to gyroscope bias.

15. The vehicle system of claim 12, further comprising a switch coupled to the secondary INS unit and configured to initialize the secondary INS unit based on a predetermined sampling rate or statistics associated with the first set of kinematic state vectors.

16. A vehicle system, comprising:

a first inertial measurement unit (IMU) comprising a first accelerometer configured to generate first acceleration measurements and a first gyroscope configured to generate first angular velocity measurements;

a global navigation satellite system (GNSS) configured to generate GNSS signals;

a primary inertial navigation system (INS) unit configured to receive the first accelerometer measurements, the first angular velocity measurements, and the GNSS signals, the primary INS unit further configured to determine a first set of kinematic state vectors based on the first accelerometer measurements, the first angular velocity measurements, and the GNSS measurements, the primary INS unit including a first Kalman filter configured to receive the GNSS signals and to determine a first set of health indicators associated with the first set of kinematic state vectors and an input filter configured to produce a second set of health indicators associated with the first set of kinematic state vectors;

a secondary INS unit configured to receive the first accelerometer measurements and the first angular velocity measurements and to determine a second set of kinematic state vectors of the vehicle based on the first accelerometer measurements and the first angular velocity measurements and independently of the GNSS signals; and

a health management system coupled to the primary INS unit and the secondary INS unit and configured to compare the first set of kinematic state vectors and the second set of kinematic state vectors to generate a third set of health indicators, the health management system further configured to determine faults associated with at least one of the first accelerometer or the first gyroscope based on at least one of the first set of health indicators, the second set of health indicators, or the third set of health indicators.

17. The INS of claim 1, wherein the health management system is configured to compare first angular orientations from the first set of kinematic state vectors and second angular orientations from the second set of kinematic state vectors to generate angular orientation differences, and wherein the health management system determines an error growth of the angular orientation differences and generates parameters for a gyroscope measurement model based on the error growth, and wherein the gyroscope measurement model forms a portion of the health management model configured to determine the fault associated with the first gyroscope.

18. The INS of claim 17, wherein the fault associated with the first gyroscope based is gyroscope bias.

19. The INS of claim 18, wherein the health management system is configured to compare first positions and first velocities from the first set of kinematic state vectors and second positions and second velocities from the second set of kinematic state vectors to generate position and velocity differences, wherein the health management system generates parameters for an acceleration measurement model based on the position and velocity differences, and wherein the acceleration measurement model forms a further portion of the health management model configured to determine the fault associated with the first accelerometer.

20. The INS of claim 19, wherein the health management system is further configured to remove the gyroscope bias from the acceleration measurement module to determine the fault associated with the first accelerometer, wherein the fault associated with the first accelerometer is acceleration bias,

wherein the primary INS unit includes primary models for determining the first set of kinematic state vectors and the secondary INS unit includes secondary models for determining the second set of kinematic state vectors, and

wherein the health management system is configured to update the primary and secondary models to remove the gyroscope bias and the acceleration bias.

* * * * *