



(12) **United States Patent**
Suddaby et al.

(10) **Patent No.:** **US 9,566,163 B2**
(45) **Date of Patent:** **Feb. 14, 2017**

(54) **EXPANDABLE SPINAL IMPLANT**

2002/30629 (2013.01); A61F 2002/30828
(2013.01); A61F 2002/30831 (2013.01); A61F
2002/448 (2013.01);

(71) Applicant: **K2M, Inc.**, Leesburg, VA (US)

(Continued)

(72) Inventors: **Loubert Suddaby**, Orchard Park, NY
(US); **Larry McClintock**, Gore, VA
(US)

(58) **Field of Classification Search**

CPC A61F 2002/30522; A61F 2002/30538;
A61F 2002/3054; A61F 2/44; A61F
2/442; A61F 2/4425; A61F 2/4455; A61F
2/447; A61F 2002/448; A61F 2/46; A61F
2/4603; A61F 2/4611; A61F 2250/0004;
A61F 2250/0006

(73) Assignee: **K2M, Inc.**, Leesburg, VA (US)

(*) Notice: Subject to any disclaimer, the term of this
patent is extended or adjusted under 35
U.S.C. 154(b) by 322 days.

See application file for complete search history.

(21) Appl. No.: **14/464,892**

(56) **References Cited**

(22) Filed: **Aug. 21, 2014**

U.S. PATENT DOCUMENTS

(65) **Prior Publication Data**

US 2015/0057755 A1 Feb. 26, 2015

5,554,191 A 9/1996 Lahille et al.

6,159,244 A 12/2000 Suddaby

(Continued)

Related U.S. Application Data

Primary Examiner — Larry E Waggle, Jr.

(60) Provisional application No. 61/868,499, filed on Aug.
21, 2013.

(74) *Attorney, Agent, or Firm* — Carter, DeLuca, Farrell
& Schmidt, LLP

(51) **Int. Cl.**

A61F 2/44 (2006.01)

A61F 2/46 (2006.01)

A61F 2/30 (2006.01)

(57) **ABSTRACT**

(52) **U.S. Cl.**

CPC *A61F 2/4425* (2013.01); *A61F 2/44*
(2013.01); *A61F 2/442* (2013.01); *A61F 2/447*
(2013.01); *A61F 2/4455* (2013.01); *A61F 2/46*
(2013.01); *A61F 2/4603* (2013.01); *A61F*
2/4611 (2013.01); *A61F 2002/3054* (2013.01);
A61F 2002/30266 (2013.01); *A61F*
2002/30281 (2013.01); *A61F 2002/30484*
(2013.01); *A61F 2002/30522* (2013.01); *A61F*
2002/30538 (2013.01); *A61F 2002/30556*
(2013.01); *A61F 2002/30566* (2013.01); *A61F*
2002/30568 (2013.01); *A61F 2002/30594*
(2013.01); *A61F 2002/30626* (2013.01); *A61F*

An expandable spinal implant configured for positioning within the intervertebral space between adjacent vertebral bodies is disclosed. The spinal implant includes a first body, a second body, a ratchet, and a locking mechanism. The first and second bodies are pivotably affixed to each other on respective first ends thereof and are capable of movement relative to each other in a medial-lateral direction with respect to the adjacent vertebral bodies. The ratchet is pivotably supported within a slot defined in the first body and is capable of engaging the second body thereby permitting movement of the first and second body relative to each other in a first direction, but not in a second direction that is different than the first direction. A method of performing spinal surgery is also disclosed.

18 Claims, 5 Drawing Sheets

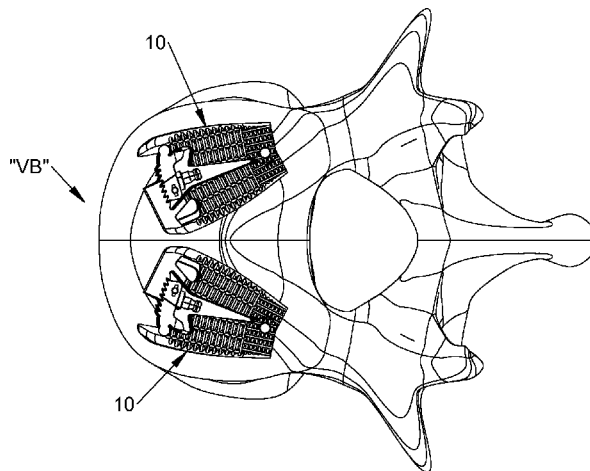

(52) U.S. Cl.

CPC A61F 2002/4475 (2013.01); A61F
2250/0004 (2013.01); A61F 2250/0006
(2013.01); A61F 2310/00023 (2013.01); A61F
2310/00029 (2013.01)

(56)

References Cited

U.S. PATENT DOCUMENTS

6,176,882	B1	1/2001	Biedermann et al.	
6,190,414	B1	2/2001	Young et al.	
6,193,757	B1 *	2/2001	Foley	A61F 2/4455 623/17.16
6,443,989	B1	9/2002	Jackson	
6,454,807	B1	9/2002	Jackson	
6,576,016	B1	6/2003	Hochshuler et al.	
6,685,742	B1	2/2004	Jackson	
6,808,537	B2	10/2004	Michelson	
6,814,756	B1	11/2004	Michelson	
7,044,971	B2	5/2006	Suddaby	
7,118,579	B2	10/2006	Michelson	
7,217,291	B2	5/2007	Zucherman et al.	
7,217,293	B2	5/2007	Branch, Jr.	
7,678,148	B2	3/2010	Peterman	
7,799,081	B2	9/2010	McKinley	
8,398,713	B2	3/2013	Weiman	
8,496,706	B2	7/2013	Ragab et al.	
8,518,114	B2	8/2013	Marik	
8,628,578	B2	1/2014	Miller et al.	
8,679,183	B2	3/2014	Glerum et al.	
8,795,366	B2	8/2014	Varela	
2004/0087947	A1	5/2004	Lim et al.	
2006/0122701	A1	6/2006	Kiester	

* cited by examiner

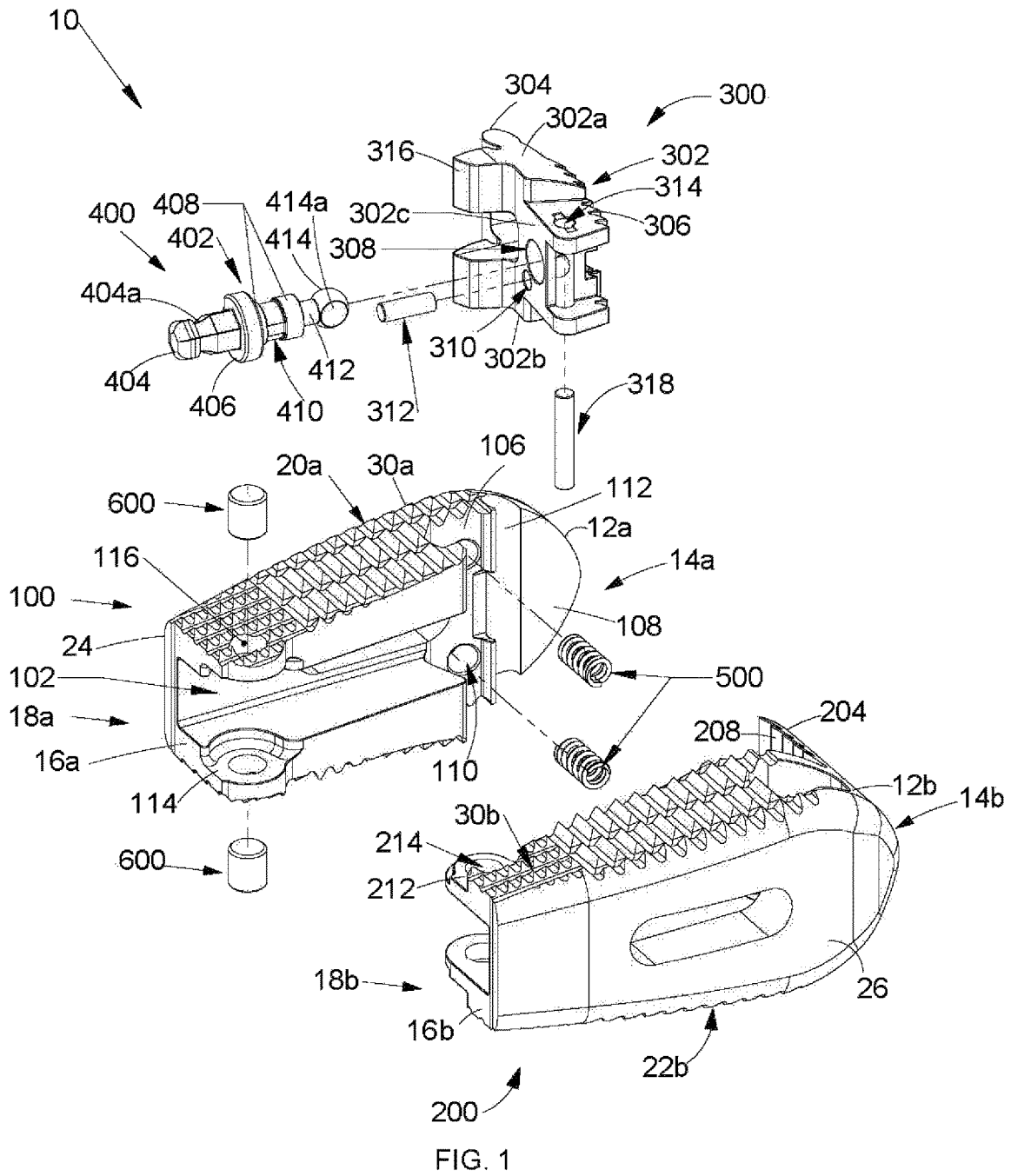

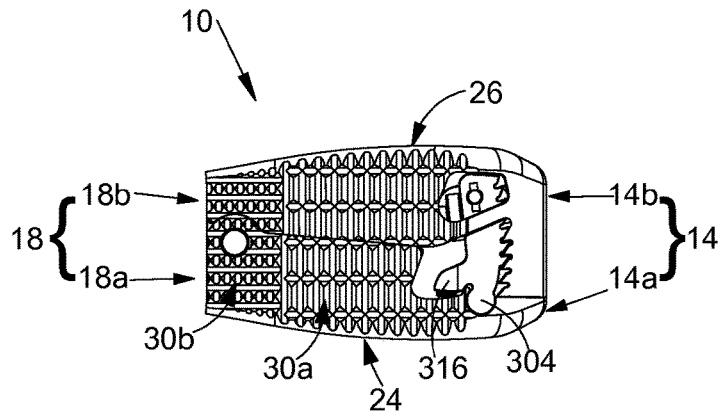

FIG. 2

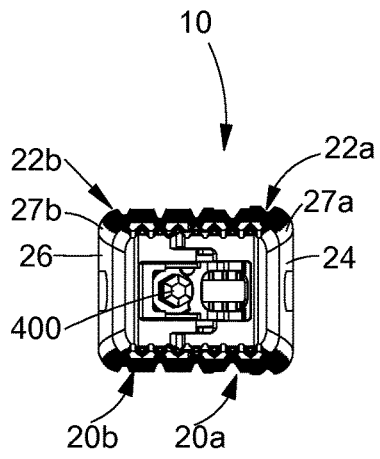

FIG. 3

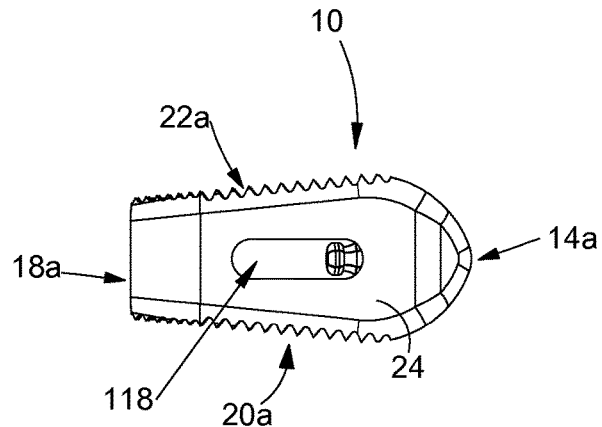

FIG. 4

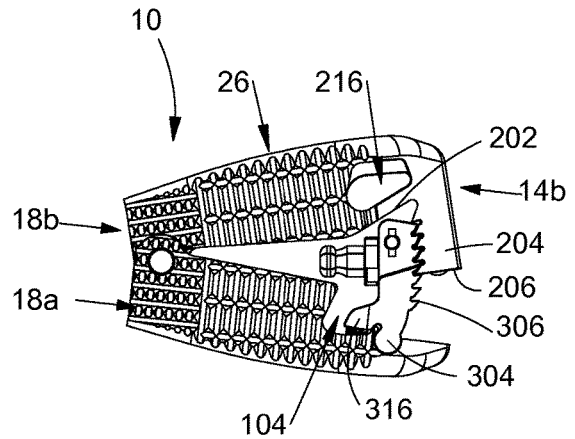

FIG. 5

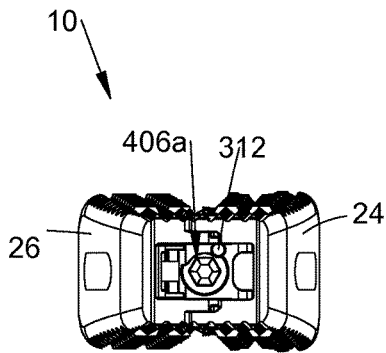

FIG. 6

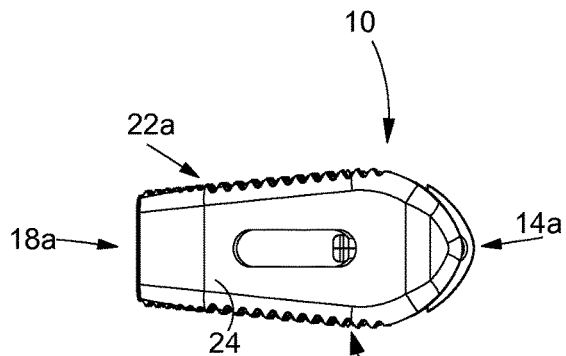

FIG. 7

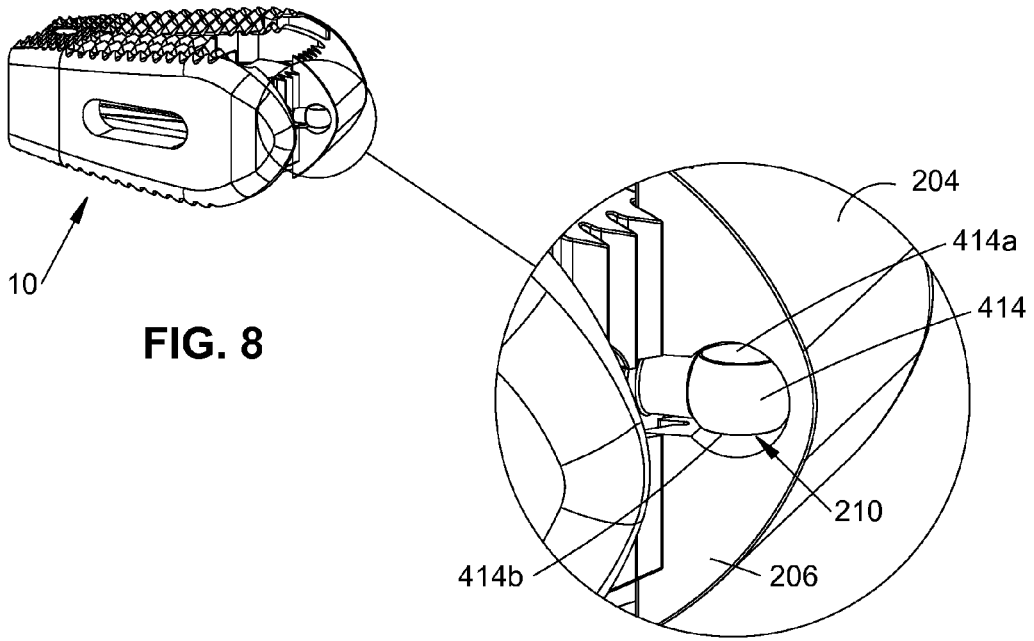

FIG. 8

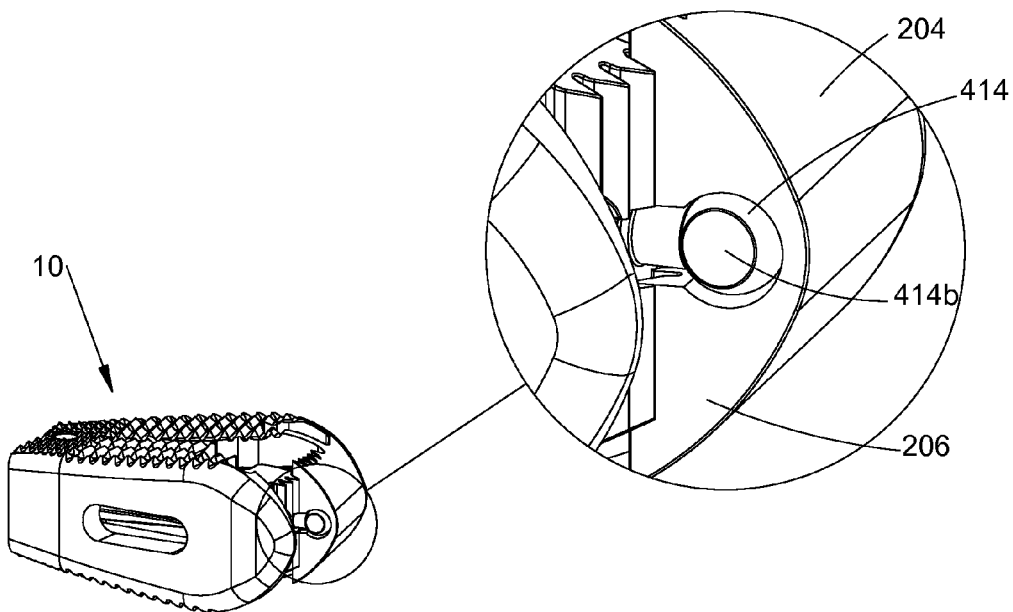

FIG. 9

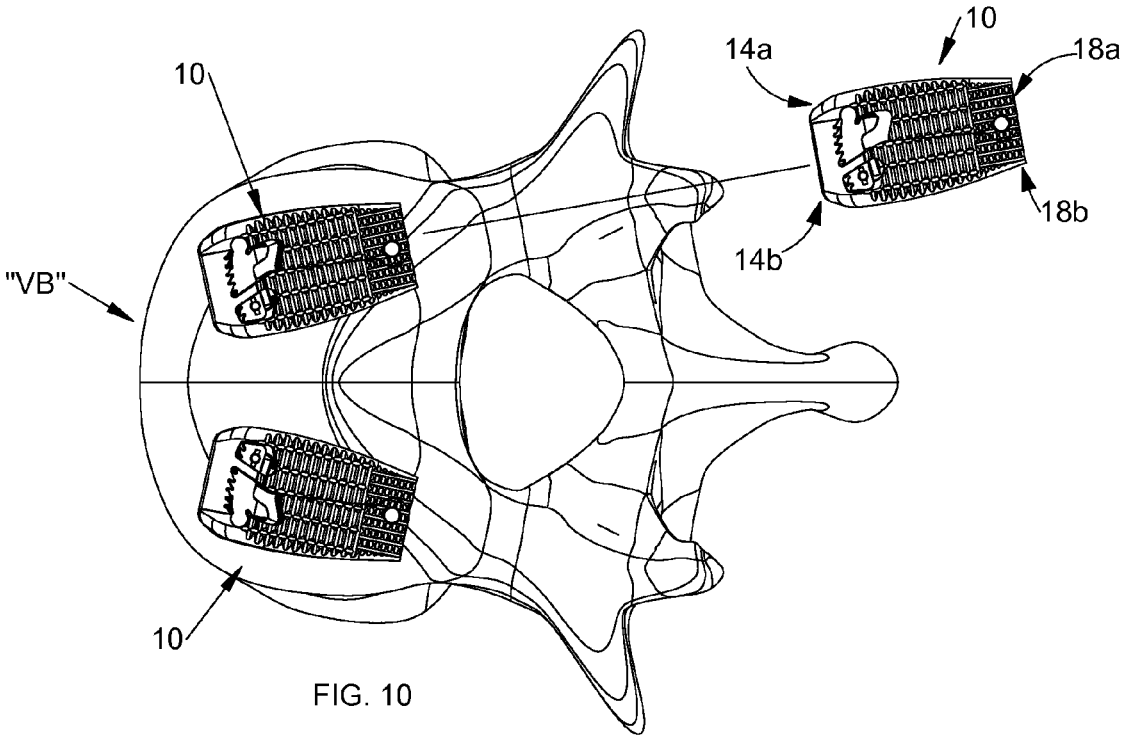

FIG. 10

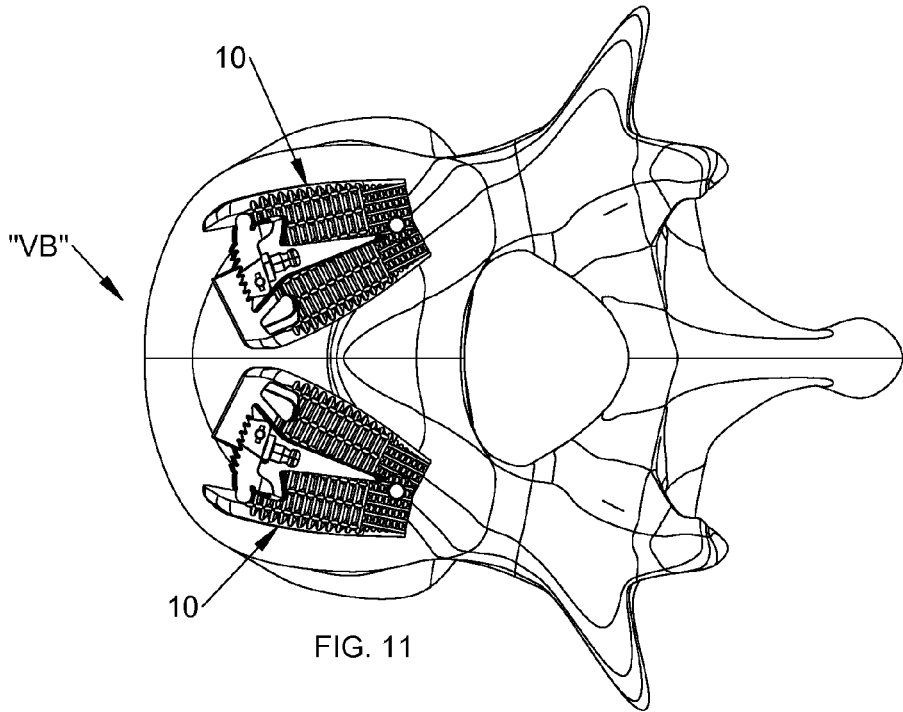

FIG. 11

1

EXPANDABLE SPINAL IMPLANT**CROSS-REFERENCE TO RELATED APPLICATION**

This application claims priority to, and the benefit of, U.S. Provisional Patent Application Ser. No. 61/868,499, filed on Aug. 21, 2013, the entire contents of which are incorporated by reference herein.

TECHNICAL FIELD

The present disclosure relates generally to devices and methods for treating spinal conditions, and in particular, to expandable spinal implants configured for positioning within an intervertebral space.

BACKGROUND

The human spine includes thirty-three vertebrae. The vertebrae interlock with one another to form a spinal column. Each vertebra has a cylindrical bony body (vertebral body), two pedicles extending from the vertebral body, a lamina extending from the pedicles, two wing-like projections extending from the pedicles, a spinous process extending from the lamina, a pars interarticularis, two superior facets extending from the pedicles, and two inferior facets extending from the lamina. The vertebrae are separated and cushioned by thin pads of tough, resilient fiber known as intervertebral discs. Intervertebral discs provide flexibility to the spine and act as shock absorbers during activity. A small opening (foramen) located between each vertebra allows passage of nerves. When the vertebrae are properly aligned, the nerves pass through without a problem. However, when the vertebrae are misaligned or a constriction is formed in the spinal canal, the nerves get compressed and may cause back pain, leg pain, or other neurological disorders.

Disorders of the spine that may cause misalignment of the vertebrae or constriction of the spinal canal include spinal injuries, infections, tumor formation, herniation of the intervertebral discs (i.e., slippage or protrusion), arthritic disorders, and scoliosis. In these pathologic circumstances, surgery may be tried to either decompress the neural elements and/or fuse adjacent vertebral segments. Decompression may involve laminectomy, discectomy, or corpectomy. Laminectomy involves the removal of part of the lamina, i.e., the bony roof of the spinal canal. Discectomy involves removal of the intervertebral discs. Corpectomy involves removal of the vertebral body as well as the adjacent intervertebral discs.

The time-honored method of addressing the issues of neural irritation and instability resulting from severe disc damage have largely focused on removal of the damaged disc and fusing the adjacent vertebral elements together. Removal of the disc relieves the mechanical and chemical irritation of neural elements, while osseous union (bone knitting) solves the problem of instability.

While cancellous bone appears ideal to provide the biologic components necessary for osseous union to occur, it does not initially have the strength to resist the tremendous forces that may occur in the intervertebral disc space, nor does it have the capacity to adequately stabilize the spine until long term bony union occurs. For these reasons, many spinal surgeons have found that interbody fusion using bone alone has an unacceptably high rate of bone graft migration, expulsion, or nonunion due to structural failures of the bone or residual degrees of motion that retard or prohibit bony

2

union. Therefore, intervertebral prostheses in various forms have been used to provide immediate stability and to protect and preserve an environment that fosters growth of grafted bone such that a structurally significant bony fusion can occur.

Many intervertebral implants have one or more fixed dimensions that may create challenges and/or lead to compromises when selecting a suitable implant for a surgical procedure.

Therefore, a need exists for an expandable spinal implant that can be inserted in a collapsed state in order to prevent over retraction of the anatomy, a reduction in surgical morbidity, and/or substandard implant sizing. Once the expandable spinal implant is in place, it can then be expanded to fill the anatomical space appropriately.

SUMMARY

In accordance with the present disclosure, a spinal implant including a first body, a second body, and a ratchet mechanism is provided. The first and second bodies are pivotably affixed to each other at respective first ends thereof and are capable of movement relative to each other. The first and second bodies are dimensioned to be installed between two vertebral bodies and the outer surfaces of each of the first and second bodies are adapted to engage the vertebral bodies. The movement of the first and second bodies is in a medial-lateral direction relative to the two vertebral bodies. A ratchet mechanism is pivotably supported within a slot defined in a recess of the first body. The ratchet mechanism is capable of engaging a portion of the second body thereby permitting movement of the first and second bodies relative to each other in a first direction, and inhibiting movement in a second direction different than the first direction.

In aspects, outer surfaces of the first body and the second body include ridges adapted to engage the first and second vertebral bodies.

In aspects, at least one biasing element is disposed within a counterbore defined in the recess of the first body. The at least one biasing element is adapted to bias the ratchet mechanism into engagement with the second body.

In aspects, the ratchet mechanism includes a first plurality of teeth disposed thereon.

In aspects, the second body includes a second plurality of teeth disposed on an interior surface thereon opposite the ratchet mechanism. The second plurality of teeth is configured to engage the first plurality of teeth of the ratchet mechanism.

In aspects, the first and second pluralities of teeth are oriented such that the first and second pluralities of teeth are slidably engaged in a first direction, and are prohibited from movement relative each other in a second direction different from the first direction, thereby defining a predetermined size of the spinal implant.

In aspects, the spinal implant further includes a locking mechanism disposed within an orifice defined in a side surface of the ratchet mechanism and a keyhole defined in an end face of the second body.

In aspects, the locking mechanism includes first and second ends, wherein the second end is capable of advancing axially within the keyhole in a first, unlocked position. The second end is also capable of locking the ratchet mechanism into a selected position when in a second, locked, position.

In aspects, the spinal implant is capable of being inserted between two vertebral bodies using a tool.

In aspects, the first and second bodies are capable of being manipulated relative to each other using a tool.

3

In aspects, the first end of the locking mechanism is attachable to a tool.

A method of performing surgery provided in accordance with the present disclosure includes providing a spinal implant comprising a first body, a second body, and a ratchet mechanism. The first and second bodies are pivotably affixed to each other at respective first ends thereof and are capable of movement relative to each other. The first and second bodies are dimensioned to be installed between two vertebral bodies and the outer surfaces of each of the first and second bodies are adapted to engage the vertebral bodies. The movement of the first and second bodies may be in a medial-lateral direction relative to the two vertebral bodies. A ratchet mechanism is pivotably supported within a slot defined in a recess of the first body. The ratchet mechanism is capable of engaging a portion of the second body thereby permitting movement of the first and second bodies relative to each other in a first direction, and inhibiting movement in a second direction different than the first direction. The method further includes positioning the first body and the second body in a first, approximated position relative each other, preparing an intervertebral space between first and second vertebral bodies to receive the spinal implant, inserting the spinal implant into the prepared intervertebral space, articulating the first body and the second body relative to each other to obtain a desired medial-lateral footprint within the intervertebral space, and locking the ratchet mechanism to define a predetermined size of the spinal implant.

In aspects, inserting the spinal implant includes first securing the spinal implant to an insertion device.

In aspects, locking the ratchet mechanism includes rotating a locking mechanism disposed within an orifice defined within a side surface of the ratchet mechanism and a keyhole defined in an end face of the second body. The locking mechanism includes first and second ends, and is capable of advancing axially within the keyhole. Rotating the tool causes the locking mechanism to rotate to a locked position.

In aspects, positioning the first body and second body in a first, approximated, position includes engaging a first plurality of teeth disposed on a surface of the ratchet mechanism with a second plurality of teeth disposed on an opposing surface of other one of the first body and second body, thereby permitting articulation of the first body relative to the second body in a first direction, but not in a second direction.

In aspects, inserting the spinal implant includes attaching an insertion instrument to the spinal implant.

In aspects, articulating the first body relative to the second body includes manipulating an insertion instrument, thereby causing the first body and the second body to articulate relative to each other.

In aspects, locking the ratchet mechanism further includes attaching a tool to a first end of the locking mechanism.

BRIEF DESCRIPTION OF THE DRAWINGS

The above and other aspects, features, and advantages of the present disclosure will become more apparent in light of the following detailed description when taken in conjunction with the accompanying drawings in which:

FIG. 1 is an exploded view, with parts separated, of an expandable spinal implant provided in accordance with the present disclosure;

FIG. 2 is a top view of the expandable spinal implant of FIG. 1, shown in a closed position;

4

FIG. 3 is an end view of the expandable spinal implant of FIG. 1, shown in the closed position;

FIG. 4 is a side view of the expandable spinal implant of FIG. 1, shown in the closed position;

FIG. 5 is a top view of the expandable spinal implant of FIG. 1, shown in an expanded position;

FIG. 6 is an end view of the expandable spinal implant of FIG. 1, shown in an expanded position;

FIG. 7 is a side view of the expandable spinal implant of FIG. 1, shown in an expanded position;

FIG. 8 is an enlarged view of a locking mechanism of the expandable spinal implant of FIG. 1, shown in an unlocked position;

FIG. 9 is an enlarged view of the locking mechanism of FIG. 8, shown in a locked position;

FIG. 10 is a plan view of an intervertebral space shown with two expandable spinal implants of FIG. 1 in a closed position; and

FIG. 11 is a plan view of the intervertebral space of FIG. 10, shown with two expandable spinal implants of FIG. 1 in an expanded position.

DETAILED DESCRIPTION OF THE EMBODIMENTS

Embodiments of the present disclosure are now described in detail with reference to the drawings in which like reference numerals designate identical or corresponding elements in each of the several views. As used herein, the term “clinician” refers to a doctor, a nurse or any other care provider and may include support personnel. Throughout this description, the term “proximal” will refer to the portion of the device or component thereof that is closer to the clinician and the term “distal” will refer to the portion of the device or component thereof that is farther from the clinician. Additionally, in the drawings and in the description that follows, terms such as front, rear, upper, lower, top, bottom, and similar directional terms are used simply for convenience of description and are not intended to limit the disclosure. In the following description, well-known functions or constructions are not described in detail to avoid obscuring the present disclosure in unnecessary detail.

Referring now to the drawings, FIG. 1 illustrates an embodiment of expandable spinal implant 10 provided in accordance with the present disclosure. Expandable spinal implant 10 includes a first body 100, a second body 200, a ratchet mechanism 300, a locking mechanism 400, biasing elements 500, and hinge pins 600. First and second bodies 100, 200 cooperate to define a two part expandable spinal implant configured for positioning between adjacent vertebral bodies. Ratchet mechanism 300 and locking mechanism 400 cooperate to provide a locking mechanism to lock first and second bodies 100, 200 in an expanded position relative to each other, thereby expanding the medial-lateral footprint of expandable spinal implant 10. Each of these components along with the assembly and insertion of expandable spinal implant 10 into the intervertebral space, as well as the expansion/contraction of expandable spinal implant 10 within the intervertebral space will be described in turn hereinbelow.

The various components of expandable spinal implant 10, or portions thereof, may be formed from various similar or different materials, depending on a particular purpose. In particular, first and second bodies 100, 200 may be formed from a metallic material (e.g., titanium, titanium alloy, or cobalt chrome (CoCr)) or a non-metallic material (e.g., polymeric materials such as polyetheretherketone (PEEK),

5

non-absorbable polymers, nylon absorbable polymers such as polyglycolides, polylactides, polycaprolactone, etc., or organic materials such as bone) and ceramic materials. Ratchet mechanism **300**, locking mechanism **400**, biasing elements **500**, and hinge pins **600** may be formed from titanium, titanium alloy, CoCr or other suitable metal or polymeric material compatible with first and second bodies **100**, **200**.

With reference to FIGS. **1**, **2**, and **8**, expandable spinal implant **10** is illustrated. Expandable spinal implant **10** is formed by first and second bodies **100**, **200**, which are operable to be positioned in an expanded state (FIG. **5**), or a closed state (FIG. **2**). Expandable spinal implant **10** includes substantially contoured first end surfaces **12a**, **12b** at a distal or leading end **14a**, **14b** of first and second bodies **100**, **200**, respectively, and second end surfaces **16a**, **16b** opposite thereto at a proximal or trailing end **18a**, **18b**, of first and second bodies **100**, **200**, respectively. Expandable spinal implant **10** extends between the first and second end surfaces **12a**, **12b** and **16a**, **16b** to define respective top and bottom surfaces **20a**, **20b**, **22a**, and **22b**, as well as opposed side surfaces **24**, **26**. As illustrated in FIG. **3**, the top and bottom surfaces **20a**, **20b** and **22a**, **22b**, engage side surfaces **24**, **26**, respectively, to provide a substantially rectangular cross-sectional profile, with rounded corners **27a**, **27b**. As best illustrated in FIGS. **2** and **4**, first end surfaces **12a**, **12b** form a substantially atraumatic blunt nose profile, and second end surfaces **16a**, **16b** form a substantially flat or planar profile. For a more detailed discussion of the profile of expandable spinal implant **10**, reference may be made to U.S. Pat. No. 8,801,791, filed on Sep. 27, 2007, entitled "Spinal Interbody Spacer," the entirety of which is incorporated herein by reference.

Referring now to FIGS. **3** and **4**, top surfaces **20a**, **20b** are generally shown as being angled with respect to bottom surfaces **22a**, **22b** in a direction from leading end **14** to trailing end **18** thereby defining a lordotic taper capable of effectuating lordosis of the spine when expandable spinal implant **10** is advanced within the intervertebral space. Although generally shown as being angled with respect to each other such that the trailing end **18** has a height that is less than a height of the leading end **14**, it is contemplated that top surfaces **20a**, **20b** and bottom surfaces **22a**, **22b** may be angled with respect to each other such that leading end **14** has a height that is less than a height of the trailing end **18**. It is also contemplated that top surface **20** may be parallel to bottom surface **22**.

As illustrated in FIGS. **1** and **4**, top and bottom surfaces **20a**, **20b**, **22a**, and **22b** define a first plurality of ridges **30a** and a second plurality of ridges **30b** arranged thereon. The first plurality of ridges **30a** are disposed proximate to leading ends **14a**, **14b** and the second plurality of ridges **30b** are disposed proximate to trailing ends **18a**, **18b**, each of which are configured to frictionally engage an adjacent surface of a vertebral body VB (i.e., a vertebral endplate) to prevent expandable spinal implant **10** from backing out of the intervertebral space since the ridges **30a** and **30b** will bite into the adjacent vertebral plate. First and second pluralities of ridges **30a**, **30b** include distinct profiles (i.e., first plurality of ridges **30a** may have an elongate triangular profile, while second plurality of ridges **30b** may have a pyramidal profile); however, it is contemplated that first and second pluralities of ridges **30a**, **30b** may have similar profiles. For a detailed discussion of the construction of exemplary ridges, reference may be made to U.S. Pat. No.

6

8,801,791, filed on Sep. 27, 2007, entitled "Spinal Interbody Spacer," the entirety of which is incorporated herein by reference.

Referring now to FIGS. **1** and **5**, an illustration of first body **100** is shown. Channel **102** is defined through first and second end surfaces **12a**, **16a** and is substantially parallel to side surface **24**; however, it is contemplated that channel **102** may approximate side surface **24** in a direction from trailing end **18a** towards leading end **14a** and vice versa. Although generally shown as having a substantially U-shaped configuration, it is contemplated that channel **102** may have other suitable cross sections, such as v-shaped, circular, or oval.

Relief **104** (FIG. **5**) is illustrated as being defined through top and bottom surfaces **20a**, **22a** adjacent to leading end **14a**, and defines faces **106**, **108**, extending substantially perpendicular to top and bottom surfaces **20a**, **22a**. Counterbores **110** are defined in face **106** and are configured and/or dimensioned to receive biasing elements **500**, such that biasing elements **500** bias ratchet mechanism **300** into engagement with teeth **208** of second body **200**, thereby permitting motion in a first direction, and inhibiting motion in a second, opposite direction. Pivot slot **112** is defined in face **108** and is open at the top and bottom surfaces **20a**, **22a**. Pivot slot **112** includes a circular cross section with less than half of the circumference open such that pivot **304** of ratchet mechanism **300** is rotatably secured therein.

Counterbores **114** are defined within each of the upper and lower inner surfaces of channel **102**, adjacent to trailing end **18a** and side surface **24**. Through-holes **116** are defined through upper surface **20a** and lower surface **22a** and are concentric with counterbore **114**. Through-holes **116** are configured to frictionally retain hinge pins **600** therein.

With reference to FIG. **4**, slot **118** is defined through side surface **24** and includes an elongate shape complimentary to that of side surface **24** of first body **100**; however, it is contemplated that slot **118** may include other suitable shapes such as circular, rectangular, or the like. It is further contemplated that slot **118** may include a plurality of individual apertures.

Referring back to FIGS. **1** and **5**, an illustration of second body **200** is shown generally as having a shape complimentary to that of first body **100** (i.e., mirrored) and thus, in the interest of brevity, only the differences between first body **100** and second body **200** will be detailed herein. Extension **204** extends from inner face **202** (adjacent to leading end **14b**) and terminates in end face **206** (FIG. **5**). Teeth **208** are disposed on an opposing face to that of first end surface **12b** and are configured to engage teeth **306** of ratchet mechanism **300** such that when in an unlocked position, first body **100** and second body **200** may pivot or rotate relative to each other in a first direction causing expandable spinal implant **10** to expand, but not in a second direction allowing expandable spinal implant **10** to contract (i.e., a direction causing first and second bodies **100**, **200** to approximate each other). Teeth **208** are generally shown as being arranged in an arcuate profile (when viewed looking towards top surface **20b**); however, it is contemplated that teeth **208** may have other suitable profiles, such as planar. Keyhole **210** (FIG. **8**) is defined through end face **206** and includes a circular cross section and an intersecting rectangular cross section such that keyhole **210** is defined through teeth **208**. Keyhole **210** is configured to receive leading end **414** of locking mechanism **400**.

Counterbores **212** are disposed within top and bottom surfaces **20b**, **22b** of second body **200** adjacent to trailing end **18b** and are complimentary to counterbores **114** of first

body **100** such that counterbores **114** and **212** interlock (i.e., counterbores **212** pass within counterbores **114**). Through-bore **214** is defined through top and bottom surfaces **20b**, **22b** and is concentric with counterbores **212**. Through-bore **214** is configured and/or dimensioned to rotatably receive hinge pins **600** therein, such that hinge pins may be pressed into through-hole **116** (held in frictional engagement) and pass through through-bore **214** such that first and second bodies **100**, **200** are pivotably/rotatably retained thereabout. Hinge pins **600** may be any suitable pin, such as a dowel pin, a roll pin, or the like.

Aperture **216** (FIG. 5) is defined through top and bottom surfaces **20b**, **22b** at a location where first end surface **14b** and side surface **26** intersect.

Continuing with FIGS. 1 and 5, an illustration of ratchet mechanism **300** is shown. Ratchet mechanism **300** includes first and second ends defining elongate body **302** therebetween. Pivot **304** is disposed on the first end of elongate body **302** and includes a substantially circular cross section extending from upper surface **302a** to lower surface **302b**. Pivot **304** is configured and/or adapted to be received within pivot slot **112** of first body **100** such that ratchet mechanism **300** is pivotably secured therein. Boss **316** extends from a side surface **302c** adjacent to pivot **304** and is configured to engage biasing elements **500**, thereby biasing ratchet mechanism **300** into engagement with teeth **208** of second body **200**, thereby permitting motion in a first direction, and inhibiting motion in a second, opposite direction. Teeth **306** are disposed on a second, opposing side surface and are configured to engage teeth **208** of second body **200**. Teeth **306** are arranged in a profile complimentary to that of teeth **208** of second body **200**, such as arcuate; however, it is contemplated that teeth **306** may be arranged in any suitable profile that is complimentary to that of the profile of teeth **208**. Orifice **308** is defined through side surface **302c** and teeth **306**, and is configured to receive locking mechanism **400** such that locking mechanism **400** is rotatably secured therein. Bore **310** is defined through side surface **302c** proximate to orifice **308** and is configured to frictionally retain limiting pin **312** therein. Limiting pin **312** may be any suitable pin, such as a dowel, a roll pin, or the like, and is disposed within bore **310**, thereby limiting the rotational motion of locking mechanism **400**. Retaining bore **314** is defined through upper surface **302a** and intersects a portion of orifice **308**, such that when retaining pin **318** is frictionally retained therein, locking mechanism **400** is prevented from advancing axially in orifice **308**. Retaining pin **318** may be any suitable pin, such as a dowel, a roll pin, or the like.

An illustration of locking mechanism **400** is shown in FIGS. 1, 8 and 9. Locking mechanism **400** includes an elongate body **402** including first and second ends. The first end of elongate body **402** includes a hexagonal cross section **404**. Hexagonal cross section **404** includes annular groove **404a** defined therein capable of engaging a suitable tool (not shown). Hexagonal cross section **404** transitions to a flange **406** having a circular cross section extending in a direction towards the second end. Flange **406** includes a larger diameter than that of hexagonal cross section **404** and is configured to abut side surface **302c** of ratchet mechanism **300**, thereby inhibiting locking mechanism from passing entirely through orifice **308**. Flange **406** includes a notch **406a** (FIG. 6). Notch **406a** is configured to act as a limiter to enable locking mechanism **400** to rotate from a first, unlocked position, to a second, locked position by engaging limiting pin **312**. Flange **406** transitions to first shank portion **408** having a circular cross section and a diameter less than that

of flange **406** and is configured and/or dimensioned to be received within orifice **308** such that locking mechanism is rotatably supported therein. Recess **410** is disposed within first shank portion **408** and includes a circular cross section having a diameter less than that of first shank portion **408**. Recess **410** is configured and/or dimensioned to receive a portion of retaining pin **312** when locking mechanism **400** is fully advanced within orifice **308**, thereby inhibiting locking mechanism **400** from translating axially within orifice **308**. First shank portion **408** transitions to second shank portion **412** having a circular cross section and a diameter less than that of first shank section **408** such that second shank portion **412** may be advanced within keyhole **210**. Second shank portion **412** transitions to leading end **414** having a spherical cross section having a diameter complimentary to that of the circular cross section portion of keyhole **210**. Leading end **414** includes opposing planar sides **414a**, **414b** disposed thereon. Opposing planar sides **414a**, **414b** reduce the diameter of leading end **414** to that of second shank portion **412** such that leading end **414** and second shank portion **412** may be advanced within keyhole **210** when locking mechanism is in an unlocked position (i.e., opposing planar sides **414a**, **414b** are parallel to upper surface **302a** of ratchet mechanism **300**), locking mechanism may advance axially within keyhole **210** as teeth **306** and teeth **208** slide past each other as first body **100** and second body **200** rotate in a first direction allowing expandable spinal implant **10** to expand (FIG. 8). Rotation of locking mechanism **400** may be effectuated using any suitable tool capable of transmitting rotational motion to locking mechanism **400**. Rotation of locking mechanism **400** to a second, locked position orients opposing planar sides **414a**, **414b** normal to upper surface **302a** of ratchet mechanism **300** (FIG. 9) such that the diameter of leading end **414** abuts the interior of keyhole **210** thereby prohibiting axial translation of locking mechanism **300** within keyhole **210**. By rotating locking mechanism **400** to the locked position, teeth **208**, **306** remain engaged with one another thereby fixing a size of expandable spinal implant **10**. In other words, expandable spinal implant **10** is prohibited from expanding or contracting with locking mechanism **400** in the locked position. It is contemplated that the tool, when advanced over hexagonal cross section **404** and retained within annular groove **404a**, may be used to retract ratchet mechanism **300** such that teeth **208**, **306** become disengaged, thereby allowing expandable spinal implant **10** to rotate in the second direction and contract.

With reference to FIGS. 1-11, the insertion of an expandable spinal implant **10** into the intervertebral space during the course of a spinal surgical procedure is described. Initially, locking mechanism **400** is placed in a first, unlocked position (FIG. 8) by rotating locking mechanism in a first direction using a suitable tool (not shown) engaged with hexagonal cross section **404** of locking mechanism **400**. Next, first body **100** is manipulated relative to second body **200** such that first and second bodies **100**, **200** are in a first, approximated, position (FIG. 2) (e.g., closed). However, it is only necessary to perform this step if first and second body **100**, **200** are not already in an approximated position. The intervertebral space is then prepared, e.g., damaged or diseased tissue is removed. Next, expandable spinal implant **10** is affixed to a suitable insertion instrument (not shown). It is contemplated that the insertion tool may also be capable of engaging the hexagonal cross section **404** of locking mechanism **400**. At this point, expandable spinal implant **10** may be advanced within an incision within the patient and thereafter, into a previously prepared intervertebral space of the patient's spine (FIG. 10). The insertion

instrument (not shown) is then manipulated to expand expandable spinal implant **10** in a medial-lateral direction to a desired location (FIG. **11**) using the insertion instrument (not shown). Medial-lateral expansion of expandable spinal implant **10** is effectuated by manipulating first and second bodies **100**, **200** about hinge pins **600**, such that teeth **208**, **306** cam, permitting rotation in the first direction, but not in a second, opposite direction. Expansion of expandable spinal implant adjusts the medial-lateral footprint within the intervertebral space. The desired location of first body **100** relative to second body **200** is selected based on the desired medial-lateral footprint of expandable spinal implant **10**. Once a desired location has been selected, locking mechanism **400** is rotated in the second, opposite direction to lock teeth **208** of second body **200** into engagement with teeth **306** of ratchet mechanism **300** thereby locking the position of first body **100** relative to second body **200**. If expandable spinal implant **10** has been expanded too far, the clinician may use a suitable tool (not shown) to retract ratchet mechanism **300** such that teeth **208**, **306** become disengaged, thereby allowing expandable spinal implant **10** to rotate or pivot in the second direction and contract.

This process may be repeated as many times as the procedure requires, whether it be for the same expandable spinal implant **10** or for a plurality of expandable spinal implants **10** as required by the procedure being performed.

Expandable spinal implant **10** may be inserted using a variety of surgical techniques including, but not limited to, an anterior approach, an anteriolateral approach, a lateral approach, a retro-peritoneal approach, or a posterior approach. Expandable implant **10** is usable in a number of procedures including, but not limited to, Anterior Lumbar Interbody Fusion (ALIF), Posterior Lumbar Interbody Fusion (PLIF), and Transforaminal Lumbar Interbody Fusion (TLIF).

It will be understood that various modifications may be made to the embodiments of the presently disclosed expandable spinal implant. Therefore, the above description should not be construed as limiting, but merely as exemplifications of embodiments. Those skilled in the art will envision other modifications within the scope and spirit of the present disclosure.

What is claimed is:

1. A spinal implant, comprising:
first and second bodies pivotably affixed to each other at respective first ends and capable of movement relative to each other, the first and second bodies dimensioned to be installed between two vertebral bodies, wherein outer surfaces of each of the first and second bodies are adapted to engage the vertebral bodies, wherein the movement of the first and second bodies is in a medial-lateral direction relative to the two vertebral bodies; and
a ratchet mechanism pivotably supported within a slot defined in a recess of the first body, the ratchet mechanism capable of engaging a portion of the second body thereby permitting movement of the first and second bodies relative to each other in a first direction, and inhibiting movement in a second direction different than the first direction.
2. The spinal implant of claim **1**, wherein outer surfaces of the first body and the second body include ridges adapted to engage the first and second vertebral bodies.
3. The spinal implant of claim **1**, wherein at least one biasing element is disposed within a counterbore defined in

the recess of the first body, the at least one biasing element adapted to bias the ratchet mechanism into engagement with the second body.

4. The spinal implant of claim **3**, wherein the ratchet mechanism includes a first plurality of teeth disposed thereon.

5. The spinal implant of claim **4**, wherein the second body includes a second plurality of teeth disposed on an interior surface thereon opposite the ratchet mechanism, the second plurality of teeth configured to engage the first plurality of teeth of the ratchet mechanism.

6. The spinal implant of claim **5**, wherein the first and second pluralities of teeth are oriented such that the first and second pluralities of teeth are slidably engaged in a first direction, and are prohibited from movement relative to each other in a second direction different from the first direction, thereby defining a predetermined size of the spinal implant.

7. The spinal implant of claim **1**, further including a locking mechanism disposed within an orifice defined in a side surface of the ratchet mechanism and a keyhole defined in an end face of the second body.

8. The spinal implant of claim **7**, wherein the locking mechanism includes first and second ends, wherein the second end is capable of advancing axially within the keyhole in a first, unlocked position, wherein the second end is capable of locking the ratchet mechanism into a selected position when in a second, locked, position.

9. The spinal implant of claim **8**, wherein the first end of the locking mechanism is attachable to a tool.

10. The spinal implant of claim **1**, wherein the spinal implant is capable of being inserted between two vertebral bodies using a tool.

11. The spinal implant of claim **1**, wherein the first and second bodies are capable of being manipulated relative to each other using a tool.

12. A method of performing surgery, comprising:
providing a spinal implant comprising:

first and second bodies pivotably affixed to each other at respective first ends and capable of movement relative to each other, the first and second bodies dimensioned to be installed between two vertebral bodies, wherein outer surfaces of each of the first and second bodies are adapted to engage the vertebral bodies; and

a ratchet mechanism pivotably supported within a slot defined in a recess of the first body, the ratchet mechanism capable of engaging a portion of the second body thereby permitting movement of the first and second bodies relative to each other in a first direction, and inhibiting movement in a second direction different than the first direction;

positioning the first body and the second body in a first, approximated position relative each other;

preparing an intervertebral space between first and second vertebral bodies to receive the spinal implant;

inserting the spinal implant into the prepared intervertebral space;

articulating the first body and the second body relative to each other to obtain a desired medial-lateral footprint within the intervertebral space; and

locking the ratchet mechanism to define a predetermined size of the spinal implant.

13. The method of claim **12**, wherein inserting the spinal implant includes the spinal implant capable of being secured to an insertion device prior to inserting the spinal implant in the prepared intervertebral space.

14. The method of claim **12**, wherein locking the ratchet mechanism includes rotating a locking mechanism disposed within an orifice defined within a side surface of the ratchet mechanism and a keyhole defined in an end face of the second body, wherein the locking mechanism includes first and second ends, wherein the second end is capable of advancing axially within the keyhole, wherein the locking mechanism is configured to be rotated to a locked position using a tool. 5

15. The method of claim **14**, wherein locking the ratchet mechanism further includes attaching a tool to a first end of the locking mechanism. 10

16. The method of claim **12**, wherein positioning the first body and the second body in a first, approximated, position includes engaging a first plurality of teeth disposed on a surface of the ratchet mechanism with a second plurality of teeth disposed on an opposing surface of the second body, thereby permitting articulation of the first body relative to the second body in a first direction, but not in a second direction. 15 20

17. The method of claim **12**, wherein inserting the spinal implant includes the spinal implant capable of being secured to an insertion instrument.

18. The method of claim **17**, wherein articulating the first body relative to the second body includes the first body and the second body configured to be articulated relative to one another using an insertion instrument. 25

* * * * *