



US009545797B2

(12) **United States Patent**
Onodera et al.

(10) **Patent No.:** **US 9,545,797 B2**
(45) **Date of Patent:** ***Jan. 17, 2017**

(54) **RECORDING MEDIUM HEATING APPARATUS AND SYSTEM INCLUDING THE RECORDING MEDIUM HEATING APPARATUS**

(52) **U.S. Cl.**
CPC **B41J 11/002** (2013.01); **B41F 3/52** (2013.01); **B41F 23/042** (2013.01); **F26B 3/20** (2013.01)

(71) Applicants: **RICOH COMPANY, LTD.**, Tokyo (JP); **SCREEN HOLDINGS CO., LTD.**, Kyoto-shi (JP)

(58) **Field of Classification Search**
CPC combination set(s) only.
See application file for complete search history.

(72) Inventors: **Ken Onodera**, Ibaraki (JP); **Genichiroh Kawamichi**, Ibaraki (JP); **Yasuhide Nakazawa**, Ibaraki (JP); **Yutaka Nagasawa**, Ibaraki (JP); **Shinji Nagayama**, Ibaraki (JP)

(56) **References Cited**

U.S. PATENT DOCUMENTS

6,079,330 A 6/2000 Aoki et al.
7,123,281 B2 * 10/2006 Okada B41J 2/32 347/228

(Continued)

FOREIGN PATENT DOCUMENTS

JP 10-202839 8/1998
JP 2008-214805 9/2008
WO WO 2008/108010 A1 9/2008

OTHER PUBLICATIONS

U.S. Office Action mailed Aug. 4, 2015, in co-pending U.S. Appl. No. 14/151,311.

(Continued)

Primary Examiner — Matthew Luu
Assistant Examiner — Tracey McMillion
(74) *Attorney, Agent, or Firm* — Oblon, McClelland, Maier & Neustadt, L.L.P.

(57) **ABSTRACT**

A recording medium heating apparatus includes a plurality of heat rollers disposed in a feeding path of a recording medium and having respective heating units; and a control unit controlling temperatures of the heating units so that the temperature of a first heat roller is lower than the temperature of a second heat roller. Further, the first and the second heat rollers are included in the plurality of heat rollers and the first heat roller is disposed on the upstream side of the second heat roller in the feeding path.

13 Claims, 15 Drawing Sheets

(73) Assignees: **Ricoh Company, Ltd.**, Tokyo (JP); **SCREEN Holdings Co., Ltd.**, Kyoto-shi (JP)

(*) Notice: Subject to any disclaimer, the term of this patent is extended or adjusted under 35 U.S.C. 154(b) by 0 days.

This patent is subject to a terminal disclaimer.

(21) Appl. No.: **14/631,420**

(22) Filed: **Feb. 25, 2015**

(65) **Prior Publication Data**
US 2015/0174921 A1 Jun. 25, 2015

Related U.S. Application Data

(62) Division of application No. 14/151,311, filed on Jan. 9, 2014, now Pat. No. 9,409,416.

Foreign Application Priority Data

Feb. 19, 2013 (JP) 2013-030361
Oct. 29, 2013 (JP) 2013-224628

(51) **Int. Cl.**
B41J 2/01 (2006.01)
B41J 11/00 (2006.01)

(Continued)

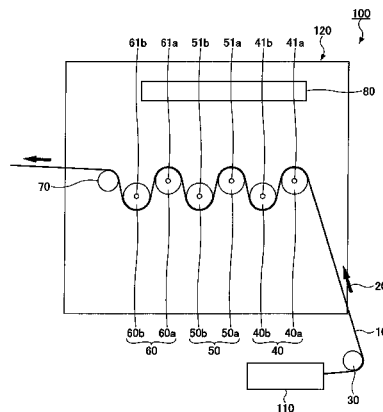

- (51) **Int. Cl.**
B41F 23/04 (2006.01)
F26B 3/20 (2006.01)
B41F 3/52 (2006.01)

(56) **References Cited**

U.S. PATENT DOCUMENTS

2002/0105630 A1* 8/2002 Hashiguchi G03D 13/002
355/405
2005/0280689 A1 12/2005 Preszler et al.
2009/0244235 A1 10/2009 Houjou
2011/0267393 A1 11/2011 Okamoto
2012/0200651 A1 8/2012 Sasada
2013/0293617 A1* 11/2013 Suzuki et al. 347/16

OTHER PUBLICATIONS

Office Action mailed Nov. 9, 2015, in co-pending U.S. Appl. No.
14/151,311.

* cited by examiner

FIG. 1

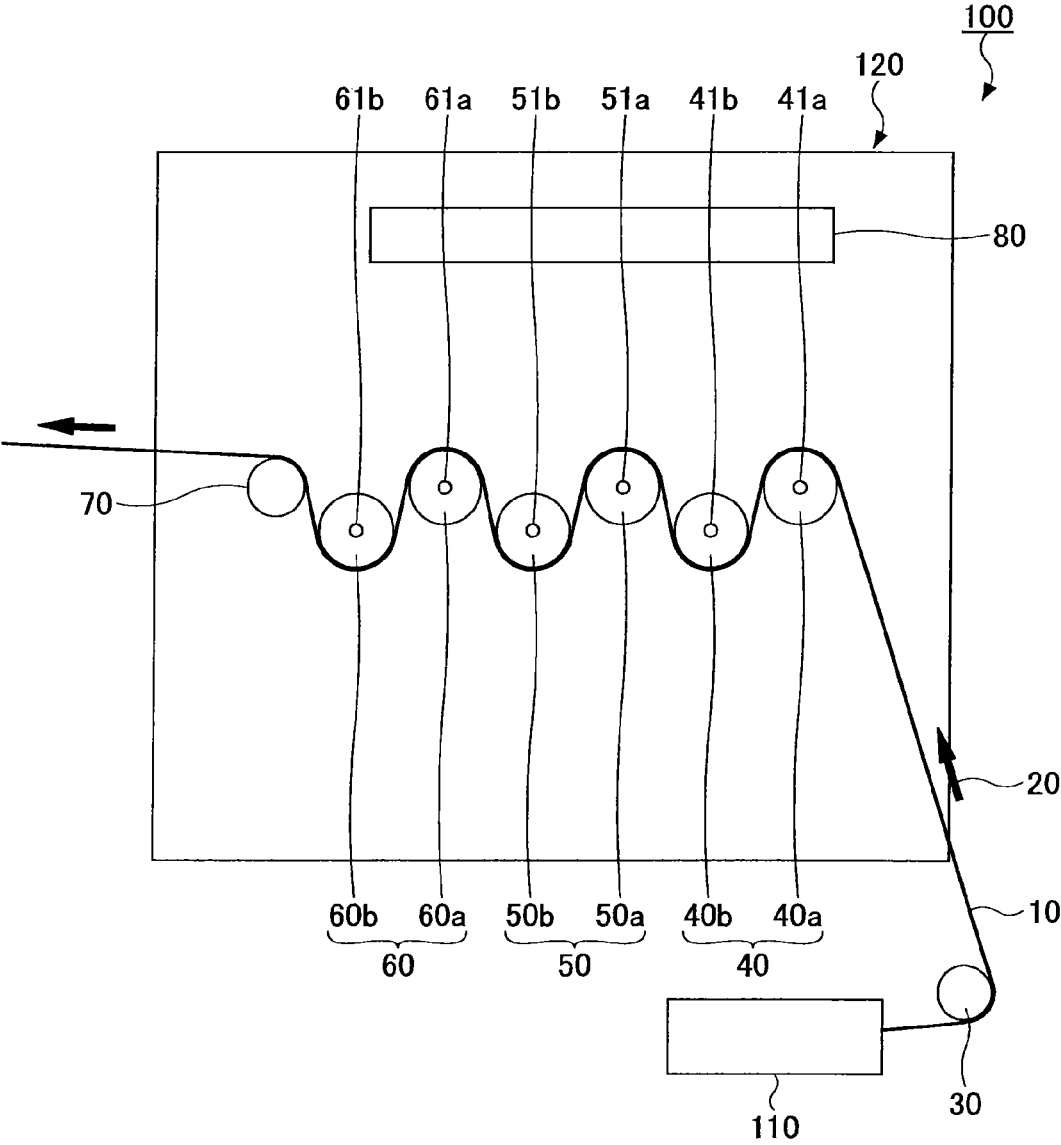

FIG.2

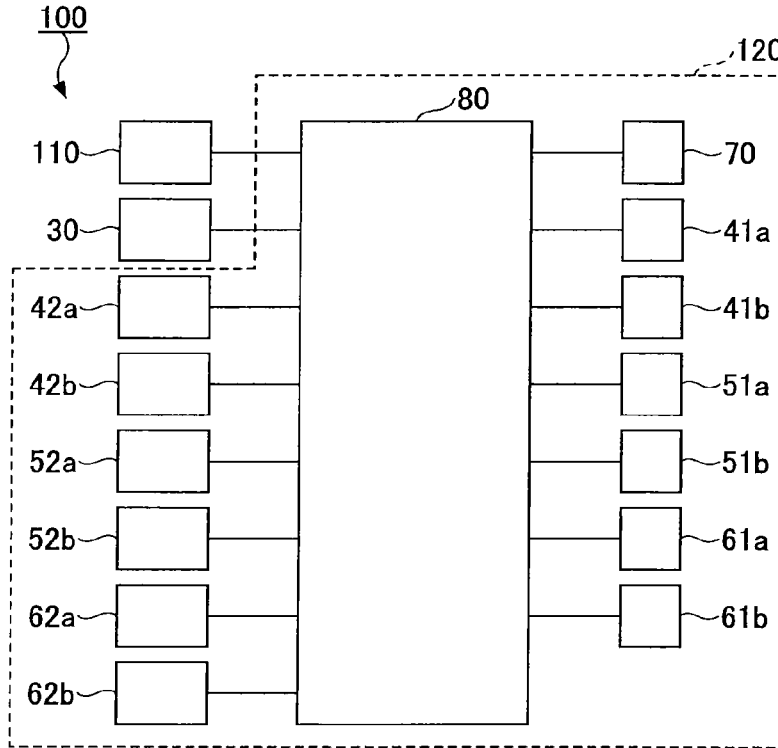

FIG.3

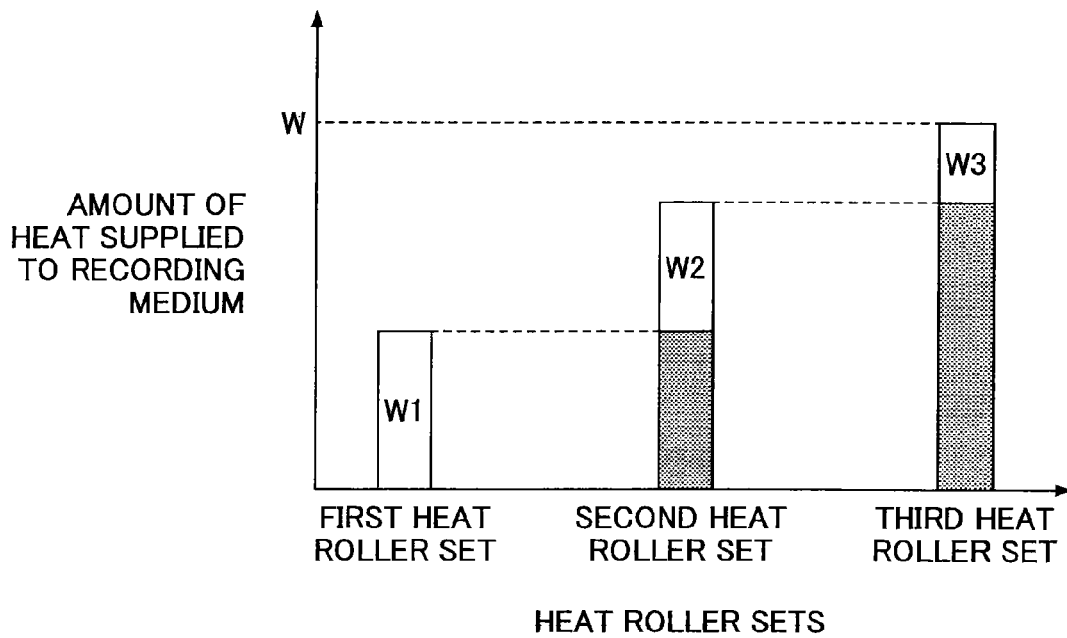

FIG. 4

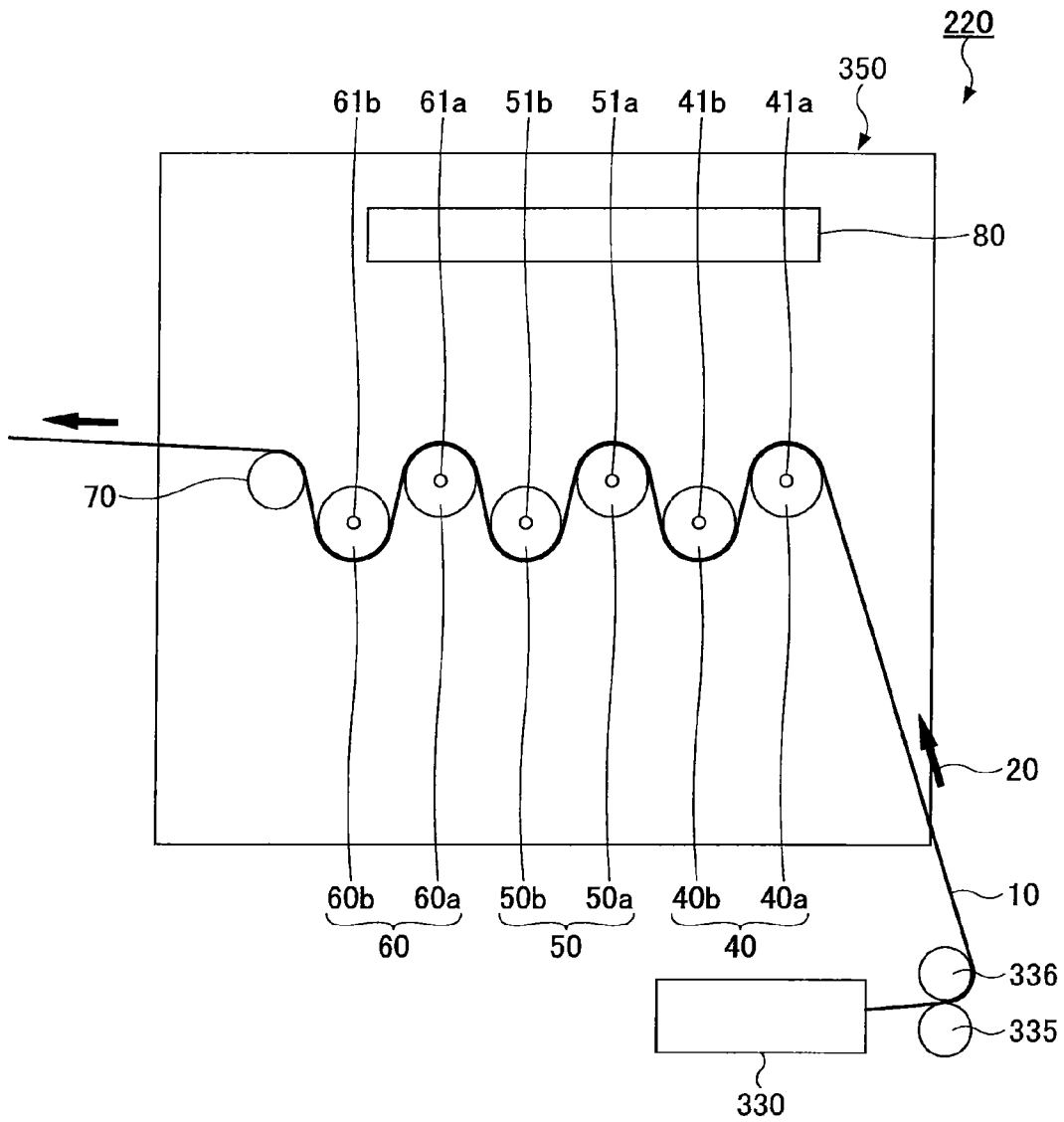

FIG. 5

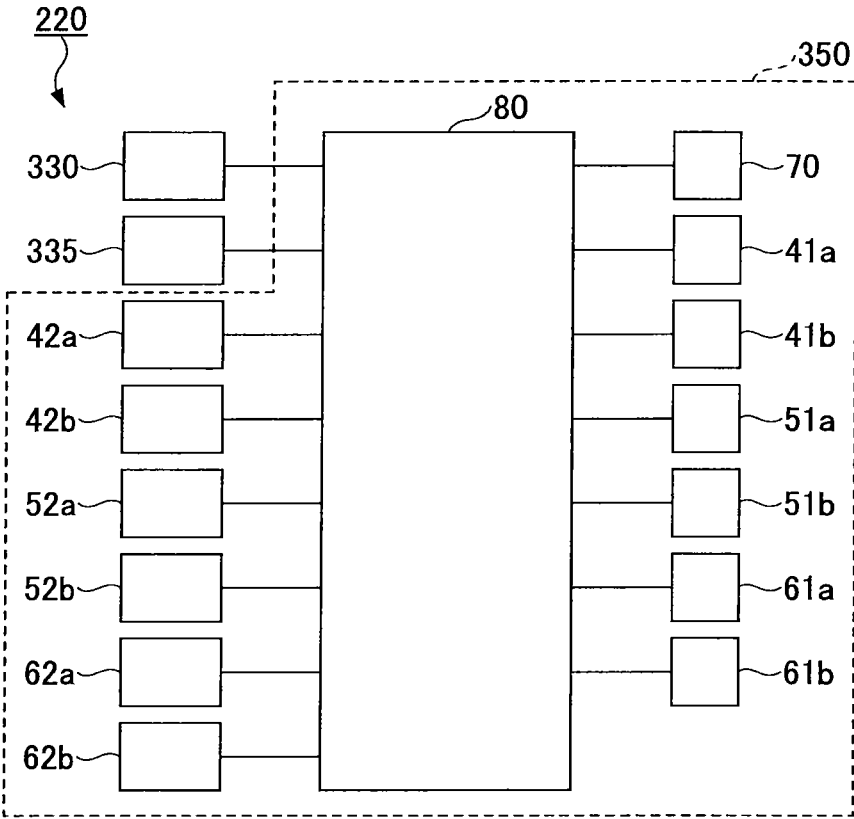

FIG. 6

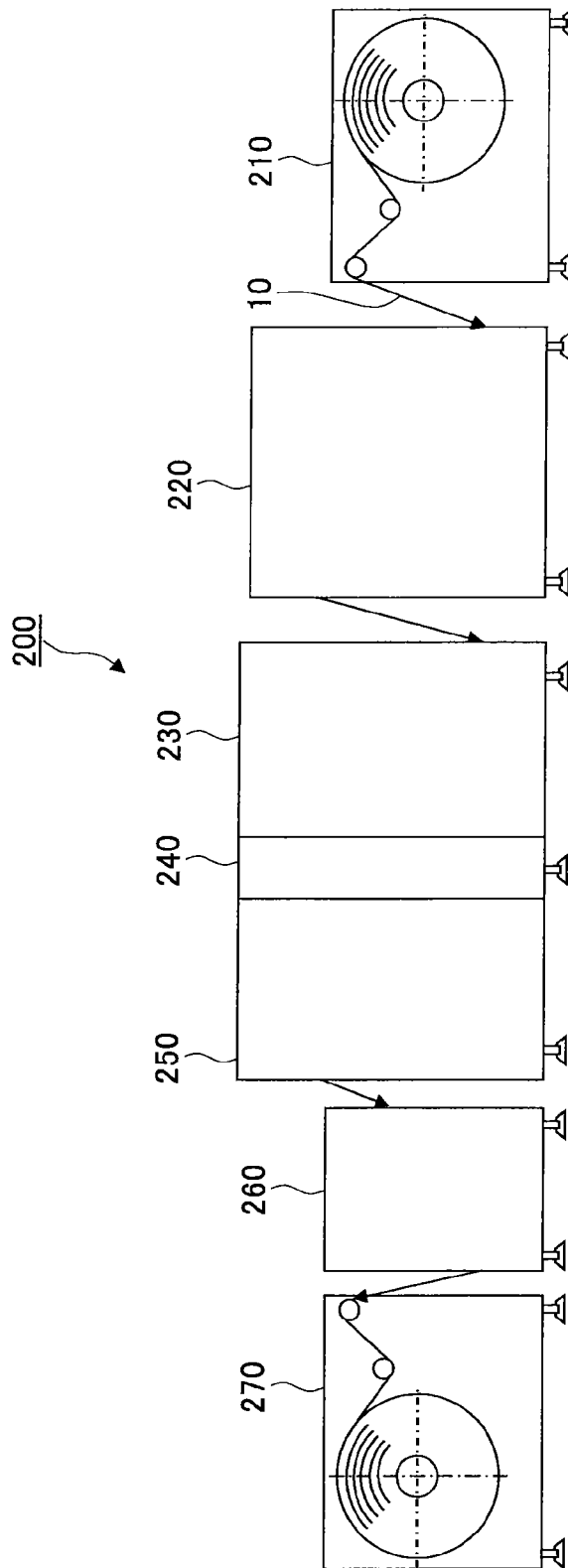

FIG. 7

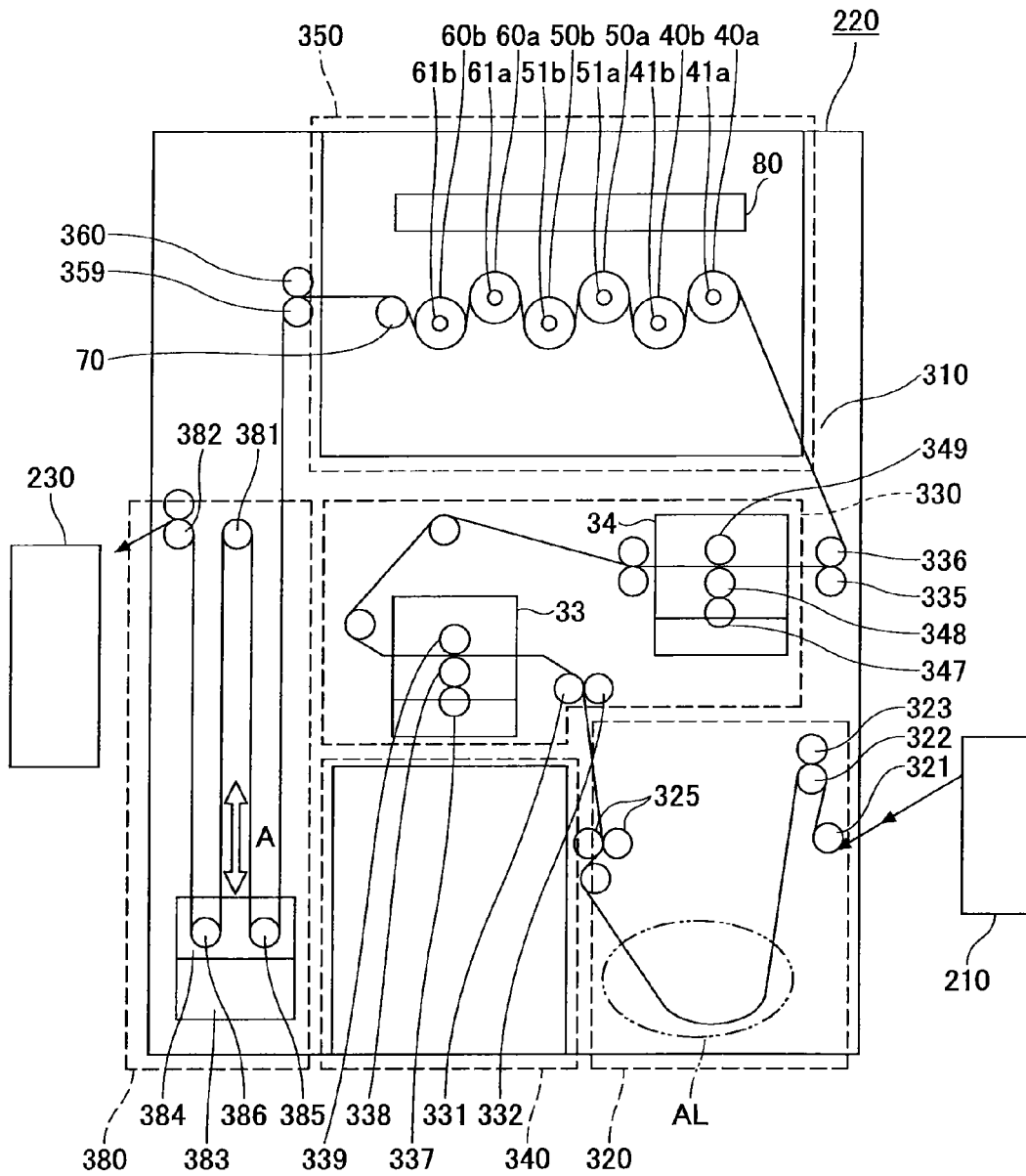

FIG.8

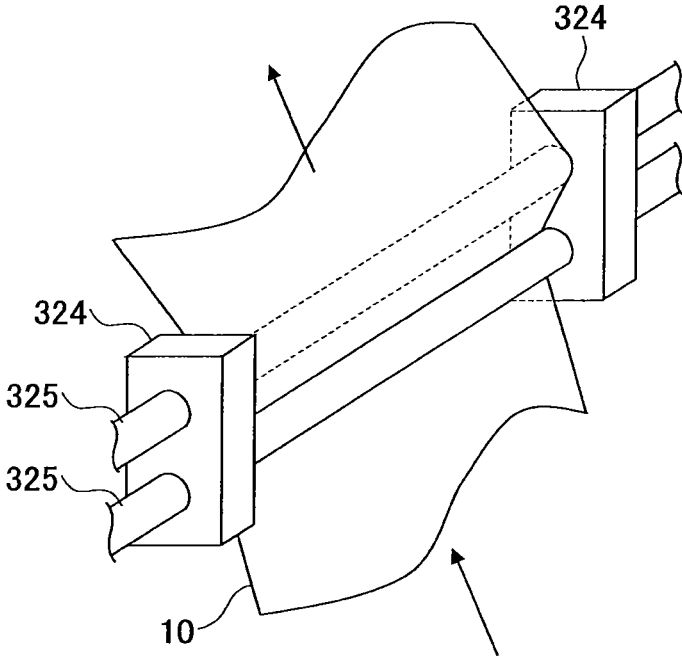

FIG.9

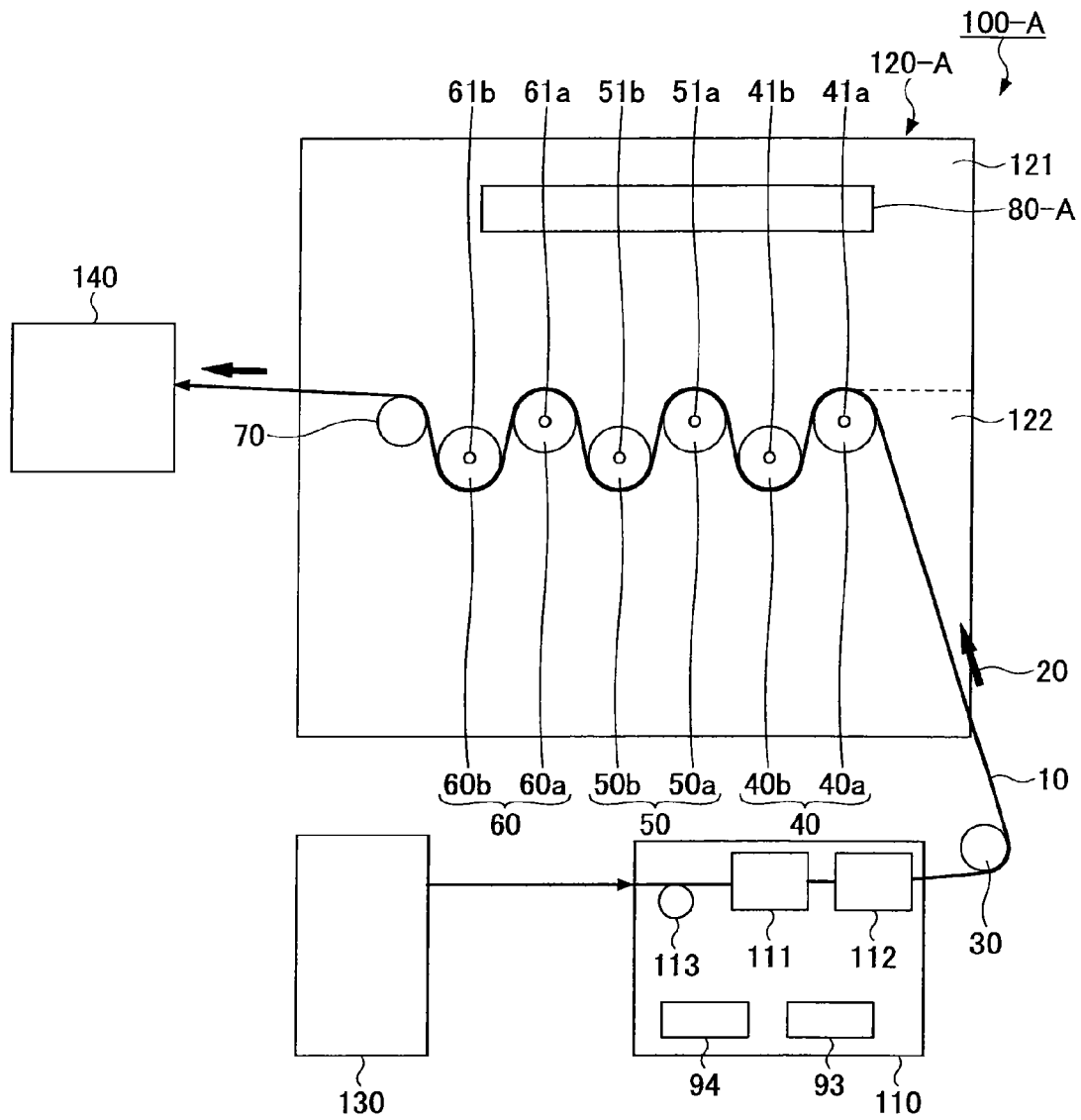
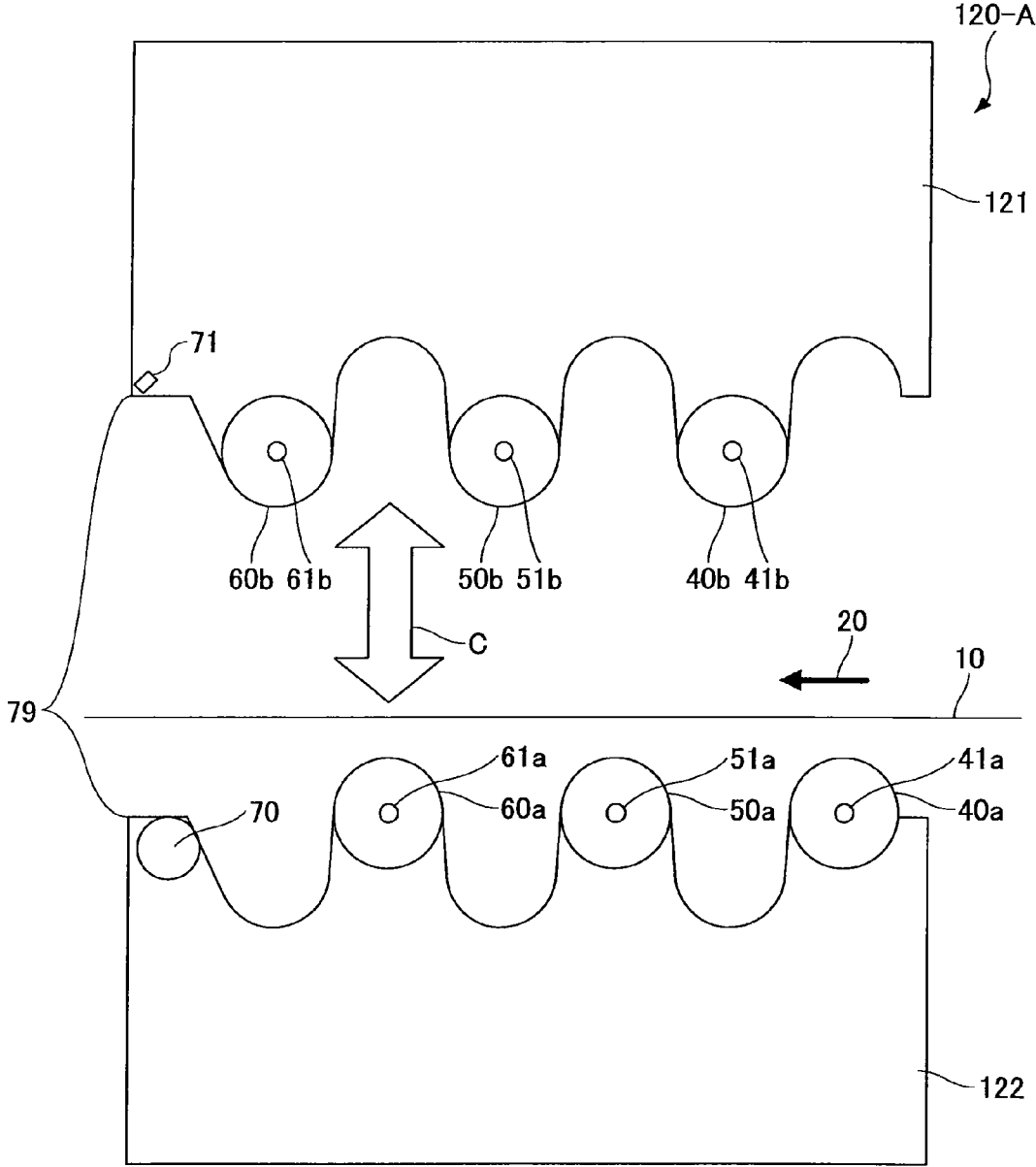

FIG.10



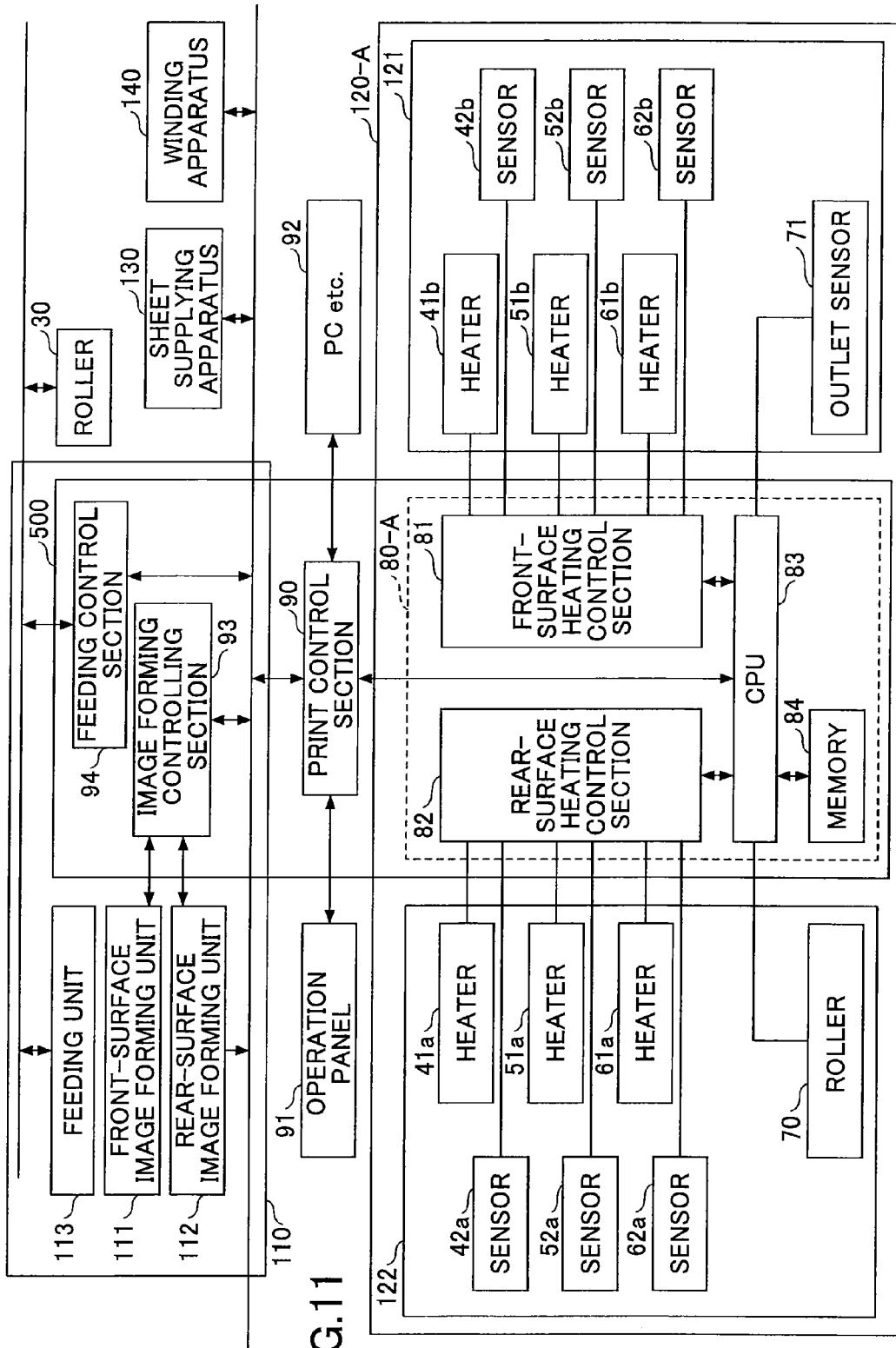

FIG. 11

FIG.12

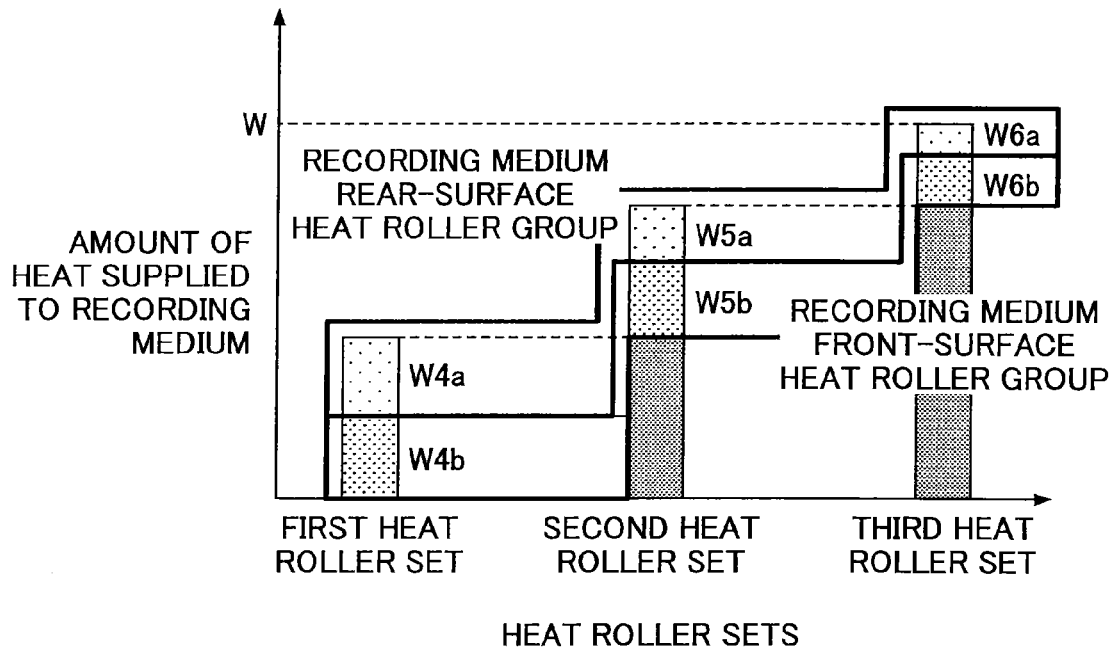

FIG.13

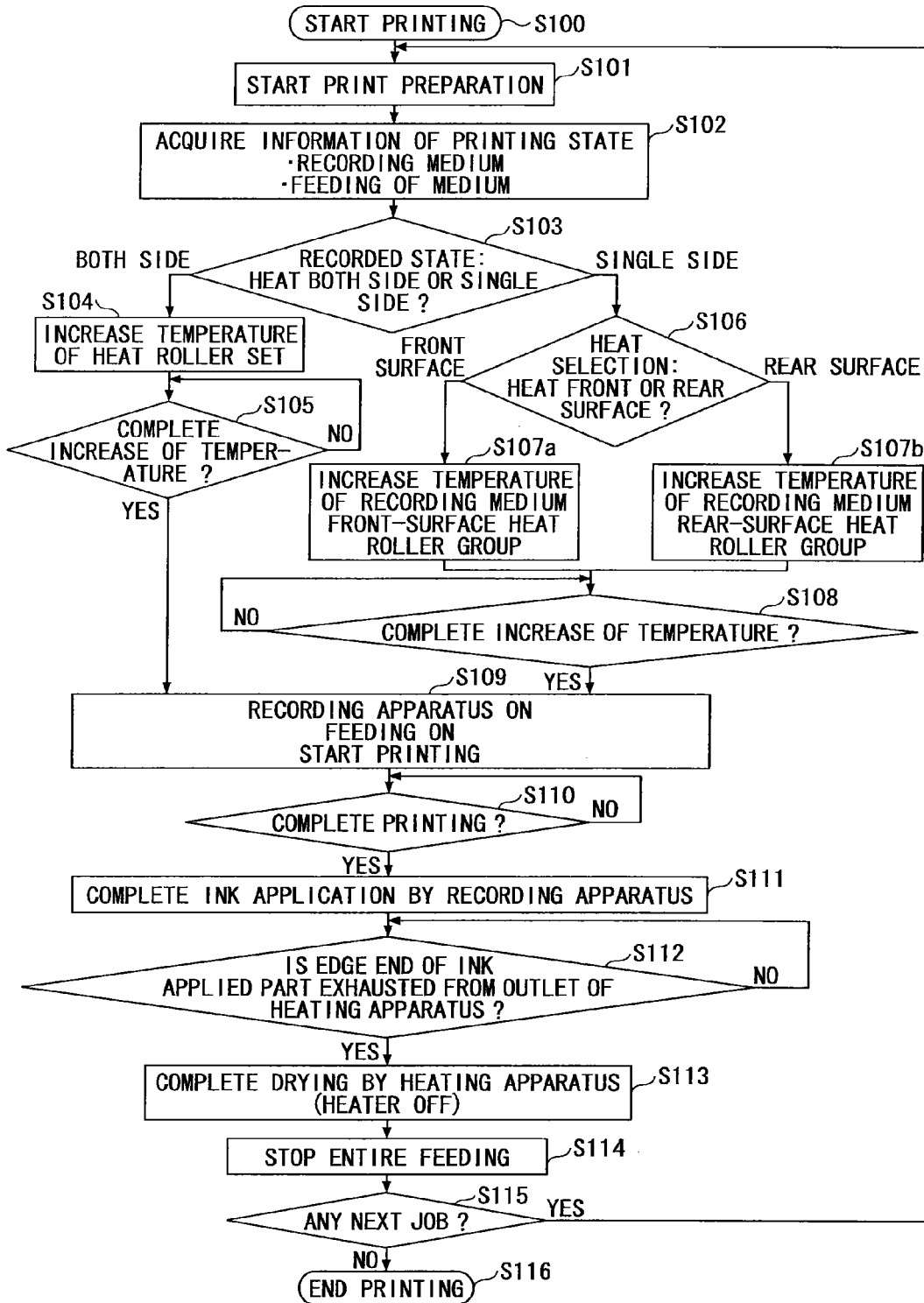
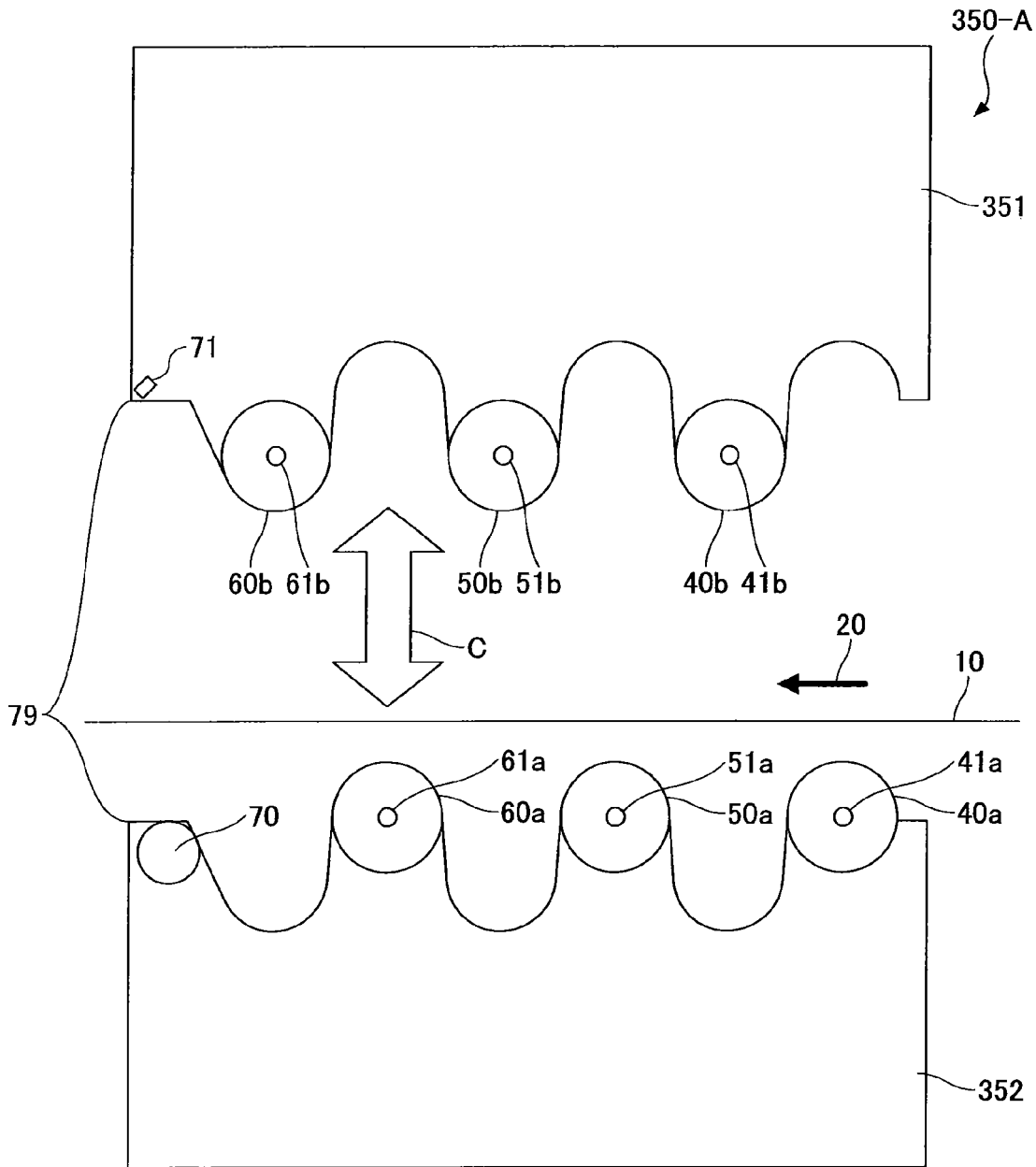

FIG. 14



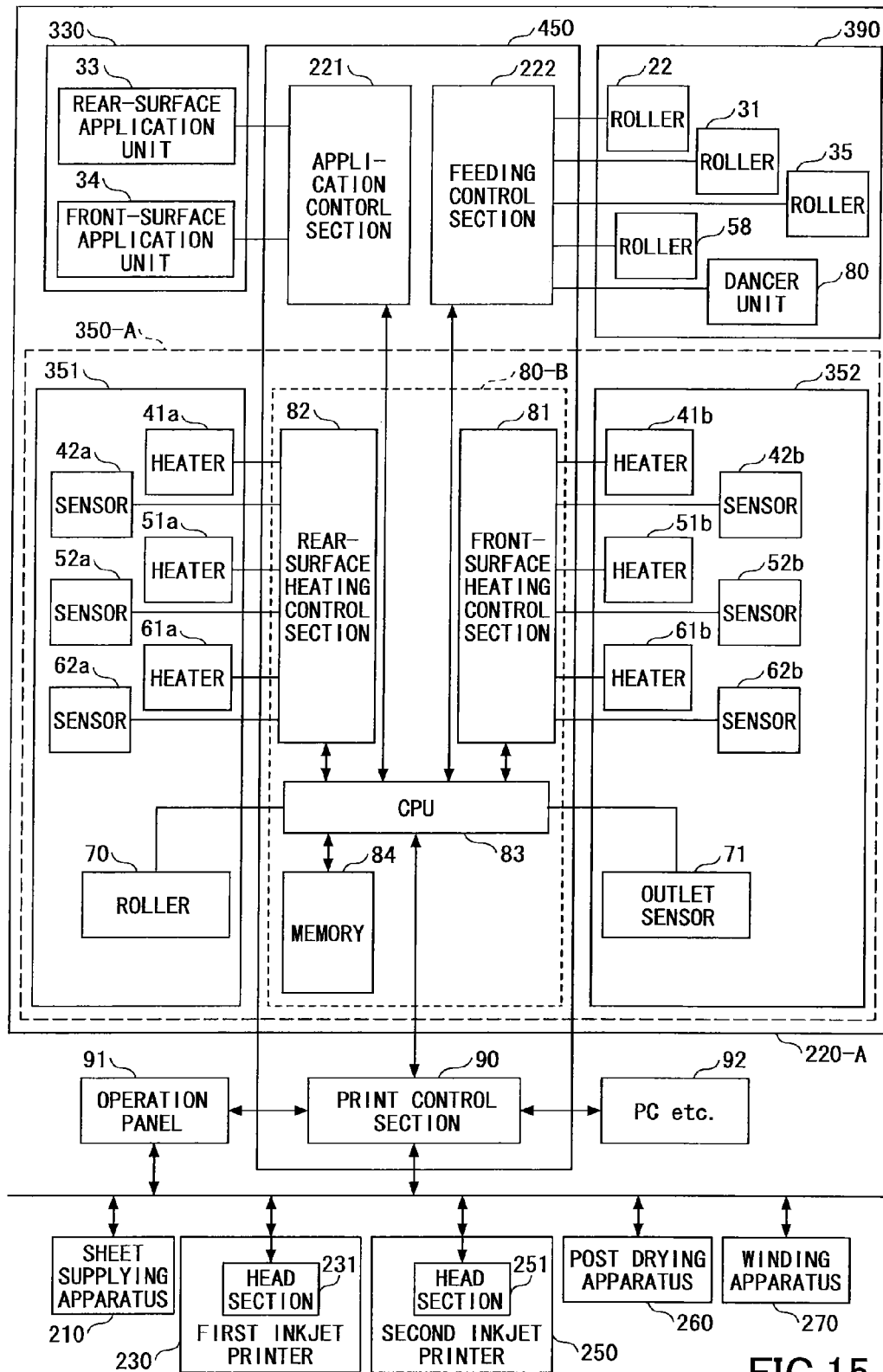
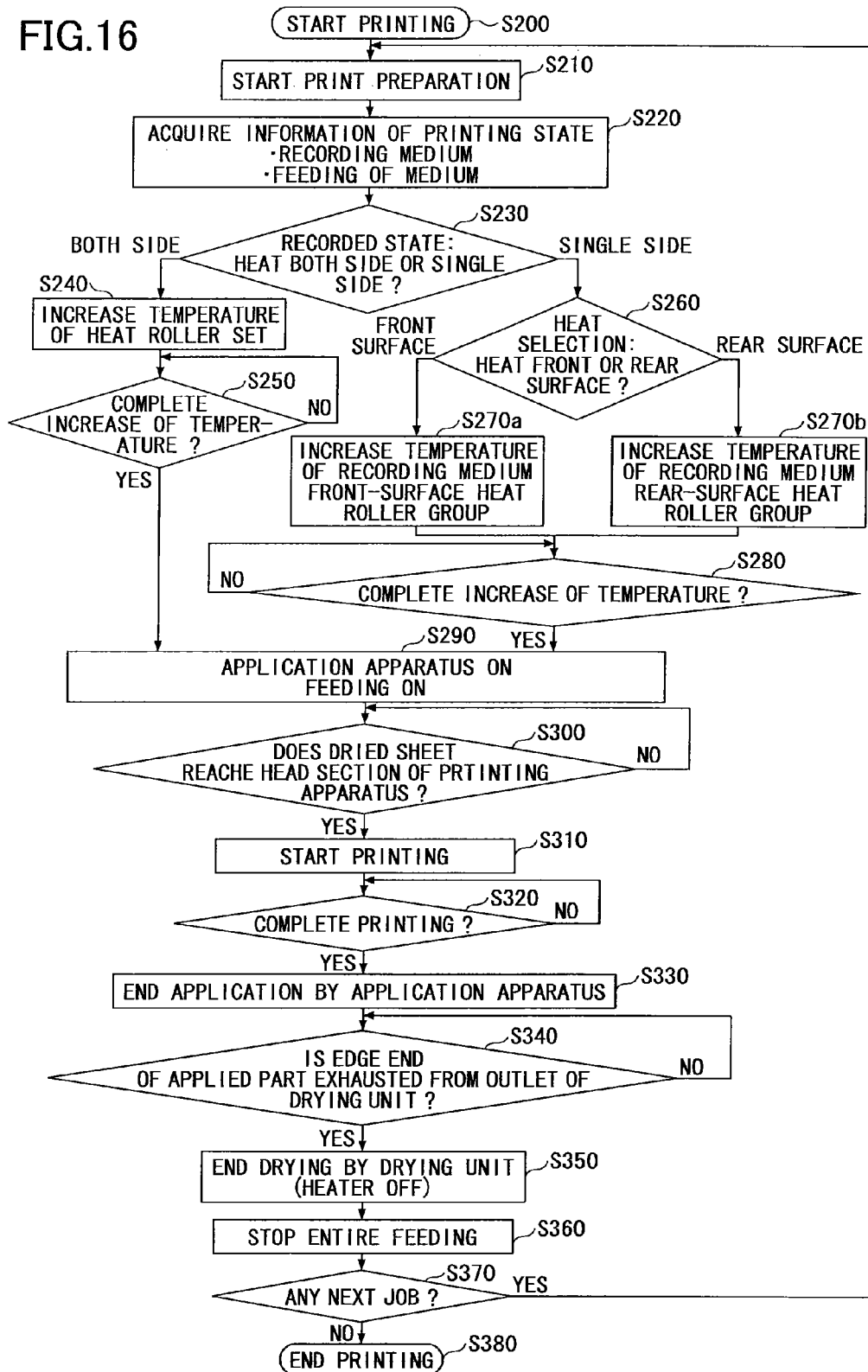

FIG. 15

FIG.16



1

RECORDING MEDIUM HEATING APPARATUS AND SYSTEM INCLUDING THE RECORDING MEDIUM HEATING APPARATUS

CROSS-REFERENCE TO RELATED APPLICATIONS

The present application is a divisional application of U.S. application Ser. No. 14/151,311, filed Jan. 9, 2014, which is based on and claims the benefit of priority under 35 U.S.C. §119 of Japanese Patent Application Nos. 2013-030361 filed on Feb. 19, 2013, and 2013-224628, filed on Oct. 29, 2013. The entire contents of the above-identified applications are incorporated herein by reference.

BACKGROUND OF THE INVENTION

1. Field of the Invention

The present invention generally relates to a recording medium heating apparatus and a system including the recording medium heating apparatus.

2. Description of the Related Art

To evaporate ink solvent printed on a sheet in a printing apparatus such as a rotary press, there is a known technique in which a plurality of heat rollers provided along the sheet feeding path are used to dry the sheet (see, for example, Japanese Laid-open Patent Publication No. H10-202839 (hereinafter "Patent Document 1")).

SUMMARY OF THE INVENTION

According to an aspect of the present invention, a recording medium heating apparatus includes a plurality of heat rollers disposed in a feeding path of a recording medium and having respective heating units; and a control unit controlling temperatures of the heating units so that the temperature of a first heat roller is lower than the temperature of a second heat roller. Further, the first and the second heat rollers are included in the plurality of heat rollers and the first heat roller is disposed on the upstream side of the second heat roller in the feeding path.

BRIEF DESCRIPTION OF THE DRAWINGS

Other objects, features, and advantages of the present invention will become more apparent from the following description when read in conjunction with the accompanying drawings, in which:

FIG. 1 schematically illustrates an example of a system including a recording medium heating apparatus according to a first embodiment of the present invention;

FIG. 2 is an example of a schematic block diagram of the system in FIG. 1;

FIG. 3 is an example of a graph illustrating a relationship between amounts of heat received by a recording medium and heat roller sets;

FIG. 4 schematically illustrates an example of a system including a preprocessing apparatus according to a second embodiment;

FIG. 5 is an example of a schematic block diagram of the system in FIG. 4;

FIG. 6 schematically illustrates an example of a printing system including the heating apparatus of FIG. 4;

FIG. 7 schematically illustrates an example of a preprocessing liquid application and drying apparatus provided in the printing system;

2

FIG. 8 is a schematic perspective view of an example of pass shafts and edge guides disposed in a feeding path of a recording medium in the preprocessing liquid application and drying apparatus of FIG. 7;

FIG. 9 schematically illustrates an example of a system including a recording medium heating apparatus according to a third embodiment of the present invention;

FIG. 10 is an exploded view of the heating apparatus of FIG. 4 in an open state;

FIG. 11 is an example of a control block diagram of the system in FIG. 9;

FIG. 12 is an example of a graph illustrating a relationship between the amounts of heat received by a recording medium and the heat roller sets of FIG. 9;

FIG. 13 is an example of a flowchart of operations of the system in FIG. 11;

FIG. 14 is an exploded view of an example of a recording medium heating apparatus in an open state according to a fourth embodiment;

FIG. 15 is an example of a control block diagram of a printing system including a preprocessing apparatus having the heating apparatus of FIG. 14; and

FIG. 16 is an example of a flowchart of operations of the system in FIG. 15.

DETAILED DESCRIPTION OF THE PREFERRED EMBODIMENTS

In related technologies of drying sheet using plural heat rollers in a printing apparatus such as a rotary press, the sheet may be damaged due to the heat applied to the sheet while in the printing apparatus.

The present invention is made in light of the problem, and may provide a recording medium heating apparatus that heats a recording medium while reducing damage to the recording medium.

In the following, embodiments of the present invention are described in detail.

First Embodiment

FIG. 1 schematically illustrates a system **100** including a recording medium heating apparatus **120** according to a first embodiment. As illustrated in FIG. 1, the system **100** includes a recording apparatus **110** and the recording medium heating apparatus **120**.

The recording apparatus **110** is a printing apparatus that forms image information by adhering ink onto a recording medium **10** and may be a rotary press (printing machine), an inkjet printer, or a facsimile machine.

The recording medium **10** is fed in the feed direction **20** as indicated by an arrow of FIG. 1 from the recording apparatus **110** to the recording medium heating apparatus **120** using a supply feed roller **30**. In the case of FIG. 1, the recording medium **10** is depicted as a continuous form.

However, the recording medium **10** may be a single sheet having a relatively longer length in the sheet feed direction. The material of the recording medium **10** is not limited to paper. Namely, the recording medium **10** may be made of a material such as a plastic sheet that is likely to be damaged by, for example, forming wrinkles or being deformed due to heat.

The recording medium heating apparatus **120** includes a first heat roller set **40**, a second heat roller set **50**, and a third heat roller set **60**, a discharge feed roller **70**, and a control apparatus **80**. The first heat roller set **40** includes a first rear-surface heat roller **40a** and a first front-surface heat roller **40b**.

The second heat roller set **50** includes a second rear-surface heat roller **50a** and a second front-surface heat roller **50b**. The third heat roller set **60** includes a third rear-surface heat roller **60a** and a third front-surface heat roller **60b**.

The first heat roller set **40**, the second heat roller set **50**, and the third heat roller set **60** are sequentially disposed in this order in the feed direction **20** along a feeding path of the recording medium **10** from an upstream side to a downstream side.

The heat rollers **40a**, **40b**, **50a**, **50b**, **60a**, and **60b** (hereinafter simplified as heat rollers “**40a-60b**”) are rotatably supported by respective bearings at both ends in the longitudinal direction thereof.

As illustrated in FIG. 1, the first rear-surface heat roller **40a**, the first front-surface heat roller **40b**, the second rear-surface heat roller **50a**, the second front-surface heat roller **50b**, the third rear-surface heat roller **60a**, and the third front-surface heat roller **60b** are separated from each other and disposed in a zigzag manner.

In this case, for example, a line connecting the rotational centers of the first rear-surface heat roller **40a**, the second rear-surface heat roller **50a**, and the third rear-surface heat roller **60a** is separated from and parallel to a line connecting the rotational centers of the first front-surface heat roller **40b**, the second front-surface heat roller **50b**, and the third front-surface heat roller **60b**.

The heat rollers **40a-60b** include respective heaters **41a**, **41b**, **51a**, **51b**, **61a**, and **61b** (hereinafter simplified as heaters “**41a-61b**”). By using the heaters **41a-61b**, it becomes possible to heat the surfaces of the heat rollers **40a-60b**.

The heat rollers **40a-60b** further include respective temperature sensors (not shown) such as thermistors, thermopiles or the like to detect the surface temperatures of the heat rollers **40a-60b**.

The heat rollers **40a-60b** may further include respective heat pipes (not shown) therein. By having the heat pipes, it may become possible to effectively transfer heat in the longitudinal direction of the heat rollers **40a-60b** and uniformly maintain the temperatures of the surfaces of the heat rollers **40a-60b** (“roller surfaces”). Accordingly, it becomes possible to effectively supply heat to the recording medium **10**.

The surfaces of the heat rollers **40a-60b** are coated with a non-adhesive film such as fluorine resin, so that adhesion of ink and the like to the roller surfaces can be reduced and reduction of the efficiency of heat transfer to the recording medium **10** due to adherence to the roller surfaces can be prevented.

The recording medium **10** is sequentially wound around the first rear-surface heat roller **40a**, the first front-surface heat roller **40b**, the second rear-surface heat roller **50a**, the second front-surface heat roller **50b**, the third rear-surface heat roller **60a**, and the third front-surface heat roller **60b** that are arranged in the zigzag manner in the feed direction from upstream to downstream. As a result, the recording medium **10** passes through the heat rollers **40a-60b** in the zigzag manner.

Accordingly, during feeding, the rear surface (“one surface”) of the recording medium **10** facing downward is in contact with the first rear-surface heat roller **40a**, the second rear-surface heat roller **50a**, and the third rear-surface heat roller **60a**.

Further, during feeding, the front surface (“the other surface”) of the recording medium **10** facing upward is in

contact with the first front-surface heat roller **40b**, the second front-surface heat roller **50b**, and the third front-surface heat roller **60b**.

FIG. 2 is an example block diagram of the system **100** in FIG. 1. As illustrated in FIG. 2, the control apparatus **80** is connected to temperature sensors **42a**, **42b**, **52a**, **52b**, **62a**, and **62b** (hereinafter temperature sensors “**42a-62b**”), the heaters **41a-61b**, the discharge feed roller **70**, the supply feed roller **30**, and the recording apparatus **110**.

The control apparatus **80** controls the temperatures of the heat rollers **40a-60b** based on actuated conditions including, for example, the temperatures of the heat rollers **40a-60b** detected by the temperature sensors **42a-62b** and the rotational speed of the discharge feed roller **70** and/or the supply feed roller **30**.

The control apparatus **80** controls the heaters **41a-61b** so that the temperature of a heat roller set disposed on the downstream side is higher or equal to the temperature of another heat roller set disposed on the upstream side among the first heat roller set **40**, the second heat roller set **50**, or the third heat roller set **60**.

More specifically, the control apparatus **80** controls the heaters **41a** and **41b** so that the temperature of the first rear-surface heat roller **40a** and the first front-surface heat roller **40b** of the first heat roller set **40** are set to a first setting temperature **T1**, controls the heaters **51a** and **51b** so that the temperature of the second rear-surface heat roller **50a** and the second front-surface heat roller **50b** of the second heat roller set **50** are set to a second setting temperature **T2**, and controls the heaters **61a** and **61b** so that the temperature of the third rear-surface heat roller **60a** and the third front-surface heat roller **60b** of the third heat roller set **60** are set to a third setting temperature **T3**.

Further, the control apparatus **80** controls the heaters **41a-61b** so that the third setting temperature **T3** is higher than or equal to the second setting temperature **T2**, the second setting temperature **T2** is higher than or equal to the first setting temperature **T1**, and the third setting temperature **T3** is higher than the first setting temperature **T1** (i.e., $T3 \geq T2 \geq T1$ and $T3 > T1$).

To that end, the control apparatus **80** may control the heaters **41a-61b** disposed in the respective heat rollers **40a-60b** while calculating (forecasting) the respective temperatures after a certain time period by monitoring the progress of the temperature changes of the heat rollers **40a-60b** and comparing the setting temperatures **T1**, **T2**, and **T3** with the current temperatures.

Otherwise, for example, the control apparatus **80** may perform two-step (on/off) control by turning on the heaters until the temperatures reach the corresponding setting temperatures and turning off the heaters when the temperatures reach the corresponding setting temperatures continuously as needed.

As illustrated in FIG. 3, the control apparatus **80** performs control so that an amount of heat supplied from the first heat roller set **40** to the recording medium **10** is **W1**, an amount of heat supplied from the second heat roller set **50** to the recording medium **10** is **W2**, and an amount of heat supplied from the third heat roller set **60** to the recording medium **10** is **W3**.

Further, the control apparatus **80** controls the heaters **41a-61b** so that a total amount of heat **W** (=amount of heat **W1**+amount of heat **W2**+amount of heat **W3**) is greater than an amount of heat that is sufficient to desirably evaporate moisture and solvent included in ink recorded on (supplied onto) the recording medium **10**. In this case, the (separate) amounts of heat supplied from the heat rollers **40a-60b** to the

5

recording medium **10** may vary depending on the time period when the recording medium is in contact with the heat rollers **40a-60b** (i.e., feeding speed of the recording medium **10**). Therefore, the control apparatus **80** changes the setting temperatures **T1**, **T2**, and **T3** based on the rotational speed of the discharge feed roller **70** and/or the supply feed roller **30**.

The recording medium **10** on which ink is printed is fed to the recording medium heating apparatus **120** by the supply feed roller **30**. The recording medium **10** fed to the recording medium heating apparatus **120** is in contact with and heated by the first rear-surface heat roller **40a** of the first heat roller set **40** that is controlled by the control apparatus **80** so that the temperature of the first rear-surface heat roller **40a** is the first setting temperature **T1**.

Then, the recording medium **10** is in contact with and heated by the first front-surface heat roller **40b** of the first heat roller set **40** that is controlled by the control apparatus **80** so that the temperature of the first front-surface heat roller **40b** is the first setting temperature **T1**.

The recording medium **10** on which ink is printed by the recording apparatus **110** is sequentially in contact with and heated by the second rear-surface heat roller **50a** and the second front-surface heat roller **50b** that are controlled by the control apparatus **80** so that the temperature thereof is the second setting temperature **T2** and is further in contact with and heated by the third rear-surface heat roller **60a** and the third front-surface heat roller **60b** that are controlled by the control apparatus **80** so that the temperature thereof is the third setting temperature **T3**.

By doing this, the solvent component of the ink printed onto the recording medium **10** is evaporated in accordance with the heat applied by the first heat roller set **40** and the second heat roller set **50**. Further, the solvent component of the ink is evaporated by the heat of the third heat roller set **60** so that the remaining solvent component of the ink printed onto the recording medium **10** is less than or equal to a corresponding predetermined value. After that, the recording medium **10** is discharged from the recording medium heating apparatus **120** by the discharge feed roller **70**.

Therefore, the recording medium **10** is in contact with the first heat roller set **40** whose temperature is the first setting temperature **T1** which is the lowest amongst the first heat roller set **40**, the second heat roller set **50**, and the third heat roller set **60**. By doing this, it becomes possible to reduce the temperature difference between the recording medium **10** and the heat roller(s) with which the recording medium **10** is in the first contact.

Accordingly, when compared with a case where the temperature of all the heat rollers is set to the third setting temperature **T3** which is the highest temperature, it becomes possible to prevent a sudden temperature increase of the recording medium **10**. Namely, it becomes possible for the system **100** to minimize a thermal load applied to the recording medium **10**. Also, it become possible for the system **100** to reduce the occurrence of damage (i.e., wrinkles, deformation and the like) to the recording medium **10** due to the thermal load.

Further, as described above, the third heat roller set **60** supplies heat to the recording medium **10** sufficient to evaporate the solvent component of ink so that the solvent component of ink is less than or equal to the corresponding predetermined value. Therefore, it becomes possible to improve the printing quality of image information formed on the recording medium **10**.

6

Further, as the recording medium **10** is fed to the second heat roller set **50** and the third heat roller set **60**, it becomes possible to gradually reduce the temperature difference between the recording medium **10** and the subsequent heat roller set. Further, it is possible to gradually reduce the amount of heat supplied from the heat roller sets **40**, **50**, and **60** when the recording medium is gradually fed from the upstream side to the downstream side.

By doing this, it becomes possible to prevent the occurrence of damage in which, for example, wire lines connected to the heaters **51a** and **51b** of the heat roller set **50** are cut due to heat load. Similarly, it becomes possible to prevent the occurrence of damage in which, for example, wire lines connected to the heaters **61a** and **61b** of the heat roller set **60** are cut due to heat load.

Further, in this first embodiment, a case is described where the control apparatus **80** controls the heaters **41a-61b** so that the temperatures of the heat roller sets **40**, **50**, and **60** are set to the corresponding setting temperatures. However, for example, the control apparatus **80** may control the heaters **41a-61b** so that the setting temperatures of the heaters **41a-61b** are different from each other. In this case, the control apparatus **80** controls the heaters **41a-61b** so that the setting temperature of the heater is gradually increased in the direction from the upstream side to the downstream side.

By doing this, it may become possible for the system **100** to effectively reduce the heat load applied to the recording medium **10**. As a result, it becomes possible to effectively prevent the occurrence of damage (e.g., wrinkles and deformation) to the recording medium due to the heat load.

Further, the control apparatus **80** may control the heaters **41a-61b** based on, for example, a type of recording medium **10** (i.e., a kind of a sheet), a type of ink, a position or an area of an image forming region (e.g., front-side printing, rear-side printing, double-sided printing, size of the printing region) and the like.

By doing this, it becomes possible for the system **100** to effectively prevent the occurrence of damage (e.g., wrinkles or deformation) to the recording medium **10** due to thermal load applied to the recording medium **10**, thereby effectively enabling the acquisition of an improvement of the printing quality.

Second Embodiment

Next, a second embodiment is described. FIG. **4** illustrates a preprocessing apparatus (preprocessing liquid application and drying apparatus) **220** having a recording medium heating apparatus **350** in a system **200**. FIG. **5** illustrates a schematic block diagram of the preprocessing apparatus **220** having the recording medium heating apparatus **350**.

In the following, the same reference numerals are repeatedly used to describe the same elements as those described in the first embodiment, so that parts different from those in the first embodiment are mainly described.

FIG. **6** illustrates a schematic configuration of a printing system **200** according to the second embodiment. As illustrated in FIG. **6**, the printing system **200** includes a sheet supplying apparatus **210**, the preprocessing apparatus **220**, a first inkjet printer **230**, a reversing apparatus **240**, a second inkjet printer **250**, a post drying apparatus **260**, and a winding apparatus **270**.

FIG. **7** schematically illustrates a configuration of the preprocessing apparatus **220** including the recording medium heating apparatus (heating unit) **350** of the printing system **200** according to the second embodiment.

The sheet supplying apparatus **210** supplies the recording medium **10** to the preprocessing apparatus **220** disposed in the downstream side, the recording medium **10** being, for example, a continuous form having a long length in the feed direction and wound into a roll shape.

The preprocessing apparatus **220** is an example of a recording medium preprocessing apparatus and applies a preprocessing liquid to the surface(s) of the recording medium **10** to prevent the occurrence of blur or ink penetration onto the rear surface of the recording medium **10** in the first inkjet printer **230** and the like disposed in the downstream side.

Further, the preprocessing apparatus **220** heats and dries the applied preprocessing liquid on the recording medium **10** and then discharges the recording medium **10** to the first inkjet printer **230** disposed in the downstream side.

To that end, the preprocessing apparatus **220** includes the recording medium heating apparatus (heating unit) **350** (see FIGS. **4** and **7**). Here, the configuration of the recording medium heating apparatus (heating unit) **350** in the preprocessing apparatus **220** is the same as that of the recording medium heating apparatus (heating unit) **120**.

Therefore, the recording medium heating apparatus (heating unit) **350** also includes the heat rollers **40a-60b**. In the recording medium heating apparatus (heating unit) **350**, the control process (see FIG. **3**) by the control apparatus **80** as described above is preformed, so as to control the amounts of heat to be supplied by the heaters **41a-61b** of the heat rollers **40a-60b**.

Based on image data to be printed, the first inkjet printer **230** discharges ink droplets onto the front surface (“the other surface”) of the recording medium **10** onto which the preprocessing liquid is applied in the preprocessing apparatus **220**, so as to form the desired image.

The reversing apparatus **240** reverses the surface of the recording medium **10**, and feeds the reversed recording medium **10** to the second inkjet printer **250**. Further, the reversing apparatus **240** includes a drier (not shown) as a drying unit to dry the image formed on the other surface of the recording medium **10** by the first inkjet printer **230**.

Based on the image data to be printed, the second inkjet printer **250** discharges ink droplets onto the rear surface (the “one surface”) of the recording medium **10** whose surfaces are reversed by the reversing apparatus **240**, so as to form the desired image.

The post drying apparatus **260** includes a drier as a drying unit which exhausts hot air to dry the image formed on the front and the rear surfaces of the recording medium **10**.

The winding apparatus **270** winds up and collects the recording medium **10** on which images are formed on one or both surfaces, wherein ink on the surfaces is dried by the post drying apparatus **260**.

Next, with reference to FIG. **7**, the preprocessing apparatus **220** is described. The preprocessing apparatus **220** corresponding to a preprocessing system in FIG. **7** includes a preprocessing liquid application apparatus (preprocessing liquid application unit) **330** that applies the preprocessing liquid to the recording medium **10**.

The recording medium heating apparatus (heating unit) **350** that dries the preprocessing liquid on the recording medium **10** is disposed on the downstream side of the preprocessing liquid application apparatus **330**.

In addition to the preprocessing liquid application apparatus **330** and the recording medium heating apparatus (heating unit) **350**, the preprocessing apparatus **220** further includes an air loop unit **320** and a preprocessing liquid supplying unit **340**, and a dancer unit **380**.

The air loop unit **320** includes a guide roller **321**, which is rotatably supported, and a feed-in (FI) roller **322** and an FI nip roller **323** which sandwiches and feeds the recording medium **10**.

In the air loop unit **320**, the guide roller **321**, the feed-in (FI) roller **322** which is driven to rotate, and the FI nip roller **323** that rotates in accordance with the rotation of the feed-in (FI) roller **322** feed the recording medium **10** supplied from the sheet supplying apparatus **210** and pull the recording medium **10** into the air loop unit **320**.

In this case, the rotation of the feed-in (FI) roller **322** is controlled by using an optical sensor (not shown) so that an air loop AL is formed where the amount of sagging of the recording medium **10** becomes constant.

Here, a tension force is applied to the recording medium **10** that has passed through the air loop AL by using a tension shaft (not shown) to stabilize the feeding of the recording medium **10**, so that the recording medium **10** is fed to the preprocessing liquid application unit **330**.

As illustrated in FIG. **8**, the recording medium **10** having passed through the air loop AL further passes between two edge guides **324** and further enters an S-shaped path through two path shafts **325** which are disposed in a manner such that the longitudinal direction of the path shafts **325** is orthogonal to the feed direction (i.e., the arrow direction in FIG. **8**) of the recording medium **10**.

The two path shafts **325** are supported by two edge guides **324**, and the distance between the two edge guides **324** is set to be substantially equal to the length in the width direction (width size) of the recording medium **10**. Here the edge guides **324** are movably fixed relative to the path shafts **325** with, for example, screws, so that the distance between the two edge guides **324** can be adjusted in accordance with the width size of the recording medium **10** to be used.

By using the path shafts **325** and the edge guides **324**, it becomes possible to determine the feeding position of the recording medium **10** in the width direction, so that stable feeding can be achieved.

To stabilize feeding of the recording medium **10**, a tension force is applied to the recording medium **10**, having passed between the path shafts **325** and the edge guides **324**, by using the tension shaft (not shown) whose position is fixed in a fixed state.

The preprocessing liquid application unit **330** includes a feed roller **331** that is driven to rotate, a feed nip roller **332**, a rear-surface application unit **33**, a front-surface application unit **34**, an outfeed roller **335** that is driven to rotate, and a feed nip roller **336**. The feed nip roller **332** and the infeed roller **331** sandwich and feed the recording medium **10**, and the feed nip roller **336** and the outfeed roller **335** sandwich and feed the recording medium **10**.

The rear-surface application unit **33** includes a squeeze roller **337**, an application roller **338**, and a pressing roller **339**. After the recording medium **10** is fed to the rear-surface application unit **33**, the recording medium **10** is sandwiched and fed between the application roller **338** and the pressing roller **339**.

In this case, the preprocessing liquid is supplied to the application roller **338** from the squeeze roller **337**, so that the application roller **338** applies the preprocessing liquid onto the one surface (i.e., the rear surface) side of the recording medium **10**. The recording medium **10** having passed through the rear-surface application unit **33** is fed to the front-surface application unit **34**.

The front-surface application unit **34** includes a squeeze roller **347**, an application roller **348**, and a pressing roller **349**, and applies the preprocessing liquid onto the other

surface (i.e., the front surface) side of the recording medium **10**. The recording medium **10** having passed through the front-surface application unit **34** is fed to the recording medium heating apparatus (heating unit) **350** which is a heating apparatus by the outfeed roller **335** and the feed nip roller **336**.

Here, the rear-surface application unit **33** and the front-surface application unit **34** are controlled so as to be selectively operated. Namely, the preprocessing liquid is applied to either one (i.e., one surface (i.e., the rear surface) or the other surface (i.e., the front surface)) or both surfaces of the recording medium **10**.

The preprocessing liquid supplying unit **340** stores the preprocessing liquid and supplies the preprocessing liquid to the rear-surface application unit **33** and the front-surface application unit **34**.

The recording medium heating apparatus (heating unit) **350** is an example of the recording medium heating apparatus, and has a configuration similar to that of the recording medium heating apparatus **120** according to an embodiment. Namely, the recording medium heating apparatus (heating unit) **350** heats the recording medium **10** to dry the preprocessing liquid applied onto the recording medium **10**.

Here, the same reference numerals are used to describe the elements having substantially the same functions as those of the elements of the recording medium heating apparatus **120**, and repeated descriptions thereof may be omitted.

The recording medium heating apparatus (heating unit) **350** has the same configuration of that of the recording medium heating apparatus **120** and includes the heat rollers **40a**, **40b**, **50a**, **50b**, **60a**, and **60b** and the control apparatus **80** from the upstream side in the feed direction **20** of the recording medium **10**.

Further, in the recording medium heating apparatus (heating unit) **350** as well, the control apparatus **80** performs the control process (see FIG. 3), so as to control the amounts of heat (i.e., temperatures) of the heaters **41a-61b** of the heat rollers **40a-60b**.

The recording medium **10** is sequentially fed between the heat rollers **40a-60b** in a zigzag manner, and fed into the recording medium heating apparatus (heating unit) **350** by the outfeed roller **335**, the feed nip roller **336**, a feed roller **359**, and a feed nip roller **360**.

The heat rollers **40a-60b** rotate in accordance with the fed recording medium **10** to heat the recording medium **10** thereby drying the preprocessing liquid applied onto the recording medium **10**.

Further, in the recording medium heating apparatus (heating unit) **350**, the heat rollers **40a-60b** rotate in accordance with the fed recording medium **10**. Therefore, it is not necessary to provide, for example, a motor as a driving unit to drive the rotation of the heat rollers **40a-60b**. As a result, it becomes possible to reduce space necessary for disposing a motor or the like.

The recording medium **10** whose preprocessing liquid applied on the surfaces thereof is dried in the recording medium heating apparatus (heating unit) **350** is sandwiched between the feed roller **359** and a feed nip roller **360** which are driven to rotate, so that the recording medium **10** is fed to a dancer unit **380**.

The dancer unit **380** includes two guide rollers **381** and **382**, a movable frame **384**, a detection unit (not shown) to detect the position of the movable frame **384**, and two dancer rollers **385** and **386** rotatably provided on the movable frame **384**. The movable frame **384** includes a weight **383** on the lower part thereof, so as to be moved along with

the dancer rollers **385** and **386** in the arrow A direction. The recording medium **10** is fed around the guide rollers **381** and **382** and the dancer rollers **385** and **386** in a W shape.

The dancer unit **380** controls the feeding amount of the feed roller **359** based on the output from the detection unit (not shown), so as to adjust the position of the movable frame **384** in the up and down direction. By adjusting the position of the movable frame **384**, it becomes possible to ensure the buffer between the preprocessing apparatus **220** and the first inkjet printer **230** disposed in the downstream side of the preprocessing apparatus **220**.

The recording medium **10** heated by the recording medium heating apparatus (heating unit) **350** is cooled by the dancer unit **380** and fed to the first inkjet printer **230** disposed on the downstream side.

By having the configuration described above, in the preprocessing apparatus **220**, the preprocessing liquid application apparatus (preprocessing liquid application unit) **330** applies the preprocessing liquid to the recording medium so as to improve the image quality by, for example, preventing the occurrence of ink blur and assisting with ink penetration.

After that, the recording medium heating apparatus (heating unit) **350** dries the preprocessing liquid and the dancer unit **380** cools the recording medium **10**. Then, the recording medium **10** is fed to the first inkjet printer **230**.

Further, the preprocessing liquid application apparatus (preprocessing liquid application unit) **330** serves as a preprocessing unit that applies the preprocessing liquid onto the front surface, the rear surface, or both surfaces of the recording medium **10**. The heating unit (recording medium heating apparatus) **350** corresponds to a preprocessing liquid drying apparatus that evaporates the preprocessing liquid.

The preprocessing apparatus **220** having such a configuration applies the preprocessing liquid onto the recording medium **10** so as to improve the image quality by, for example, preventing the occurrence of ink blur and assisting with ink penetration. The preprocessing apparatus **220** applies the preprocessing liquid onto the front surface, or the rear surface, or both surfaces of the recording medium **10**.

Further, the control apparatus **80** controls the heaters **41a-61b** so that a total amount of heat W (=amount of heat W1+amount of heat W2+amount of heat W3) is greater than an amount of heat that is sufficient to evaporate water (moisture) of the preprocessing liquid applied onto the recording medium **10**.

Further, the control apparatus **80** changes the setting temperatures T1, T2, and T3 (i.e., amounts of heat supplied from the heat rollers to the recording medium **10**) based on the feeding speed, the type of the recording medium **10** (i.e., the sheet type), the applied amount of the preprocessing liquid (e.g., an application pattern such as a double-sided application or a single-sided application) or the like.

Table 1 illustrates the relationships amongst the conditions, which are determined based on the feeding speed, the sheet type, and the application amount of the preprocessing apparatus; the first setting temperature T1 of the first rear-surface heat roller **40a** and the first front-surface heat roller **40b**; the second setting temperature T2 of the second rear-surface heat roller **50a** and the second front-surface heat roller **50b**; and the third setting temperature T3 of the third rear-surface heat roller **60a** and the third front-surface heat roller **60b**.

TABLE 1

CONDITIONS		HEAT ROLLER SETTING TEMPERATURES [° C.]			
FEEDING SPEED [m/min]	SHEET TYPE	APPLICATION AMOUNT OF PREPROCESSING LIQUID	FIRST SETTING TEMPERATURE T1	SECOND SETTING TEMPERATURE T2	THIRD SETTING TEMPERATURE T3
50	COATED SHEET A	PATTERN A	50	65	80
30	COATED SHEET A	PATTERN B	40	50	60
50	COATED SHEET B	PATTERN A	60	75	90
30	COATED SHEET B	PATTERN B	50	60	70
50	COATED SHEET C	PATTERN A	90	105	120
30	COATED SHEET C	PATTERN B	80	90	100

15

As shown in Table 1, in a first case where the feeding speed is 50 m/min, the recording medium **10** is a coat sheet A, and the application amount of the preprocessing apparatus is indicated as a pattern A, the first setting temperature **T1**, the second setting temperature **T2**, and the third setting temperature **T3** are set to 50° C., 65° C., and 80° C., respectively (i.e., **T1**=50° C., **T2**=65° C., and **T3**=80° C.).

Further, in a second case where the feeding speed is 30 m/min slower than the first case, the recording medium **10** is coat sheet A, and the application amount of the preprocessing apparatus is indicated as a pattern B which is less than pattern A, the first setting temperature **T1**, the second setting temperature **T2**, and the third setting temperature **T3** are set to 40° C., 50° C., and 60° C., respectively (**T1**=40° C., **T2**=50° C., and **T3**=60° C.). Namely, the setting temperatures **T1**, **T2** and **T3** are lower than the corresponding temperatures in the case where the feeding speed is higher than the second case.

Further, in a third case where the feeding speed is 50 m/min, the recording medium **10** is a coat sheet B, and the application amount of the preprocessing apparatus is indicated as pattern A, the first setting temperature **T1**, the second setting temperature **T2**, and the third setting temperature **T3** are set to 60° C., 75° C., and 90° C., respectively (**T1**=60° C., **T2**=75° C., and **T3**=90° C.). Namely, the setting temperatures **T1**, **T2** and **T3** are higher than the corresponding temperatures in the case where the sheet type is sheet A.

Further, in a fourth case where the feeding speed is 30 m/min, the recording medium **10** is coat sheet B, and the application amount of the preprocessing apparatus is indicated as pattern B, the first setting temperature **T1**, the second setting temperature **T2**, and the third setting temperature **T3** are set to 50° C., 60° C., and 70° C., respectively (**T1**=50° C., **T2**=60° C., and **T3**=70° C.). Namely, the setting temperatures **T1**, **T2** and **T3** are lower than the corresponding temperatures in the case where the feeding speed is higher than the fourth case.

Further, in a fifth case where the feeding speed is 50 m/min, the recording medium **10** is a coat sheet C, and the application amount of the preprocessing apparatus is indicated as pattern A, the first setting temperature **T1**, the second setting temperature **T2**, and the third setting temperature **T3** are set to 90° C., 105° C., and 120° C., respectively (**T1**=90° C., **T2**=105° C., and **T3**=120° C.). Namely, the setting temperatures **T1**, **T2** and **T3** are higher than the corresponding temperatures in the case where the sheet type is A or B.

Further, in a sixth case where the feeding speed is 30 m/min, the recording medium **10** is coat sheet C, and the application amount of the preprocessing apparatus is indicated as pattern B, the first setting temperature **T1**, the

second setting temperature **T2**, and the third setting temperature **T3** are set to 80° C., 90° C., and 100° C., respectively (**T1**=80° C., **T2**=90° C., and **T3**=100° C.). Namely, the setting temperatures **T1**, **T2** and **T3** are lower than the corresponding temperatures in the case where the feeding speed is higher than the sixth case.

Further, it should be noted that the values of the above setting temperatures are examples only, and the present invention is not limited to the invention based on these values. Further, the setting temperatures are appropriately set based on, for example, experiments.

The recording medium **10** on which the preprocessing liquid is applied by the preprocessing liquid application unit **330** is fed to the recording medium heating apparatus (heating unit) **350** by the supply feed roller **30**. The recording medium **10** fed to the supply feed roller **30** is in first contact with and heated by the first rear-surface heat roller **40a** of the first heat roller set **40** that is controlled to have the first setting temperature **T1** by the control apparatus **80**.

After that, the recording medium **10** is in contact with and heated by the first front-surface heat roller **40b** that is similarly controlled to have the first setting temperature **T1**. Then, the recording medium **10** is in contact with and heated by the second rear-surface heat roller **50a** of the second heat roller set **50** that is controlled to have the second setting temperature **T2** by the control apparatus **80**. After that, the recording medium **10** is in contact with the second front-surface heat roller **50b** that is similarly controlled to have the first setting temperature **T2** to be heated.

In the same manner, the recording medium **10** is in contact with and heated by the third rear-surface heat roller **60a** of the third heat roller set **60** that is controlled to have the third setting temperature **T3** by the control apparatus **80**. After that, the recording medium **10** is in contact with and heated by the third front-surface heat roller **60b** that is similarly controlled to have the first setting temperature **T3**.

By doing this, the moisture (water) of the preprocessing liquid applied to the recording medium **10** is evaporated in accordance with the heat applied by the first heat roller set **40** and the second heat roller set **50**. Further, due to the heat applied by the third heat roller set **60**, the moisture of the preprocessing liquid on the recording medium **10** is evaporated so that the moisture is less than or equal to a corresponding predetermined value. After that, the recording medium **10** is discharged from the recording medium heating apparatus (heating unit) **350** by the discharge feed roller **70**.

Therefore, the recording medium **10** is in first contact with the first heat roller set **40** whose temperature is the first setting temperature **T1** that is the lowest among the first heat roller set **40**, the second heat roller set **50**, and the third heat

13

roller set 60. By doing this, it becomes possible to reduce the temperature difference between the recording medium 10 and the heat roller(s) with which the recording medium 10 is in first contact.

Accordingly, when compared with a case where the temperature of all the heat rollers is set to the third setting temperature T3 which is the highest temperature, it becomes possible to prevent a sudden temperature increase of the recording medium 10. Namely, it becomes possible for the system 200 to minimize a thermal load applied to the recording medium 10. Also, it become possible for the system 100 to reduce the occurrence of damage (i.e., wrinkles, deformation and the like) to the recording medium 10 due to the thermal load.

Further, as described above, the third heat roller set 60 supplies heat to the recording medium 10 sufficient to evaporate the moisture of preprocessing liquid so that the moisture of the preprocessing liquid is less than or equal to the predetermined value. Therefore, it becomes possible for the system 200 to ensure drying of the preprocessing liquid applied to the recording medium 10 so as to prevent the blurring of ink used in printing an image onto the recording medium and assist the ink's penetration to improve the printing quality of image information formed on the recording medium 10.

Further, in the second embodiment, a case is described where the control apparatus 80 controls the heaters 41a-61b so that the temperatures of the heat roller sets 40, 50, and 60 are set to the corresponding setting temperatures. However, for example, the control apparatus 80 may control the heaters 41a-61b so that the setting temperatures of the heat rollers 40a, 40b, 50a, 50b, 60a, and 60b (heat rollers 40a-60b) are different from each other. In this case, the control apparatus 80 controls the heaters 41a-61b so that the setting temperature of the heat rollers 40a-60b is gradually increased in the direction from the upstream side to the downstream side.

By doing this, it may become possible for the system 200 to effectively reduce the heat load applied to the recording medium 10. As a result, it becomes possible to effectively prevent the occurrence of damage (e.g., wrinkles and deformation) to the recording medium due to the heat load.

Third Embodiment

Next, a system (printing system) 100-A including a recording medium heating apparatus (ink drying apparatus) 120-A according to a third embodiment is described. FIG. 9 schematically illustrates a configuration of the overall system including the recording medium heating apparatus (ink drying apparatus) 120-A. In the following, the same reference numerals are used to describe the same elements in the first embodiment, and the elements different from those in the first embodiment are mainly described.

As illustrated in FIG. 9, in the system (printing system) 100-A, there is a sheet supplying apparatus 130 disposed on the upstream side of the recording apparatus 110. Also, a winding apparatus 140 is disposed on the downstream side of the recording medium heating apparatus (ink drying apparatus) 120-A. Instead of the winding apparatus 140, a folding machine to fold the printed recording material 10 may be disposed.

The recording apparatus 110 includes a front-surface image forming unit 111, a rear-surface image forming unit 112, a feeding section 113, an image forming controlling section 93, and a feeding control section 94. In the recording apparatus 110, the front-surface image forming unit 111 and the rear-surface image forming unit 112, which may be, for

14

example, a inkjet head section, form an image on the recording medium 10 by discharging liquid such as ink onto the recording medium 10.

The recording medium heating apparatus (ink drying apparatus) 120-A includes the first heat roller set 40, the second heat roller set 50, and the third heat roller set 60, the discharge feed roller 70, and a control apparatus 80-A. The first heat roller set 40 includes the first rear-surface heat roller 40a and the first front-surface heat roller 40b.

The second heat roller set 50 includes the second rear-surface heat roller 50a and the second front-surface heat roller 50b. The third heat roller set 60 includes the third rear-surface heat roller 60a and the third front-surface heat roller 60b. The control apparatus 80-A controls the heat rollers 40a-60b and the discharge feed roller 70.

FIG. 10 is an exploded view of the recording medium heating apparatus (ink drying apparatus) 120-A in its open state. As illustrated in FIG. 10, there is a front-surface heating unit 121, which includes the first front-surface heat roller 40b, the second front-surface heat roller 50b, and the third front-surface heat roller 60b, on the upper side of the ink drying apparatus (heating apparatus) 120-A.

On the other hand, there is a rear-surface heating unit 122, which includes the first rear-surface heat roller 40a, the second rear-surface heat roller 50a, the third rear-surface heat roller 60a, and the discharge feed roller 70 on the lower side of the ink drying apparatus (heating apparatus) 120-A. Further, there is formed an outlet 79 of the ink drying apparatus (heating apparatus) 120-A, and there is an outlet sensor 71 disposed near the outlet 79. Further, the control apparatus 80-A and the outlet sensor 71 may be disposed in either the front-surface heating unit 121 or the rear-surface heating unit 122.

During the feeding of the recording medium 10, the rear surface (the other surface) of the recording medium 10 facing downward is in contact with the first rear-surface heat roller 40a, the second rear-surface heat roller 50a, and the third rear-surface heat roller 60a.

Further, the front surface (one surface) of the recording medium 10 facing upward is in contact with the first front-surface heat roller 40b, the second front-surface heat roller 50b, and the third front-surface heat roller 60b.

Further, FIG. 10 illustrates the open state where the front-surface heating unit 121 and the rear-surface heating unit 122 are separated from each other in the arrow C direction (i.e., in the up-and-down direction). When the recording medium 10 is loaded (placed), the recording medium 10 is fed between the front-surface heating unit 121 and the rear-surface heating unit 122 in this open state.

After the recording medium 10 is passed between the front-surface heating unit 121 and the rear-surface heating unit 122, the front-surface heating unit 121 and the rear-surface heating unit 122 are moved so as to approach each other to be in contact with each other via the recording medium ("closed state") as shown in FIG. 9.

By doing this, it be easy to load (place) the recording medium to be fed in the feed direction (arrow 20) between the rear-surface heating unit 122, the front-surface heating unit 121 and the rear-surface heating unit 122 in the ink drying apparatus (heating apparatus) 120-A.

FIG. 11 is a block diagram of the system including the ink drying apparatus (heating apparatus) 120-A. As illustrated in FIG. 11, the control apparatus 80-A of the ink drying apparatus (heating apparatus) 120-A is included in a control system 500 of the printing system) 100-A.

The control apparatus 80-A of the ink drying apparatus (heating apparatus) 120-A includes a front-surface heating

15

control section **81**, a rear-surface heating control section **82**, a CPU **83**, and a memory **84**.

Although not being illustrated, the control apparatus **80-A** further includes a RAM and a ROM storing a program to be executed for heating, an I/O (input section) which controls the input and output of an electric component such as a sensor, and an I/F (interface section) for receiving data from a print control section **90**.

The control system **500** of the system (printing system) **100-A** includes the ink drying apparatus (heating apparatus) **120-A**, the control apparatus **80-A**, the print control section **90**, which controls the recording apparatus **110**, the image forming controlling section **93** and the feeding control section **94**.

Further, the print control section **90** is connected to an operation panel **91**, a personal computer (including a server or the like) **92**, the sheet supplying apparatus **130**, and the winding apparatus **140** via plural data lines and control lines, so as to perform control on overall operations including ink drying.

The print control section **90** performs, for example, a raster image processor (RIP) process in accordance with the print job data supplied from a host apparatus and generates bit map data for each of certain colors of the print image data. Also, the print control section **90** generates control information for controlling printing operations based on the print job data and the information of the host apparatus. The print control section **90** may be provided in the recording apparatus **110**.

In the recording apparatus **110**, the image forming controlling section **93** connected to the print control section **90** controls the front-surface image forming unit **111** and the rear-surface image forming unit **112**. Further, the feeding control section **94** is connected to the supply feed roller **30** and the discharge feed roller **70**, which are connected to the ink drying apparatus (heating apparatus) **120-A**, and control the feeding of the recording medium **10**.

In the control apparatus **80-A** of the ink drying apparatus (heating apparatus) **120-A**, the CPU **83** controls the front-surface heating control section **81** and the rear-surface heating control section **82**.

In the control apparatus **80-A**, the front-surface heating control section **81** is connected to the temperature sensors **42b**, **52b**, and **62b** which detect the temperatures of the heat rollers **40b**, **50b**, and **60b**, respectively, and the heaters **41b**, **51b**, and **61b** in the front-surface heating unit **121**. Also, the rear-surface heating control section **82** is connected to the temperature sensors **42a**, **52a**, and **62a** which detect the temperatures of the heat rollers **40a**, **50a**, and **60a**, respectively, and the heaters **41a**, **51a**, and **61ab** in the rear-surface heating unit **122**.

In this embodiment, the control apparatus **80-A** monitors an operating state of the front-surface image forming unit **111** and the rear-surface image forming unit **112**, and controls the heaters **41a-61b** of the heat rollers **40a-60b** in a manner described below. The control apparatus **80-A** controls the heaters **41a-61b** provided in the heat rollers **40a-60b** so that the surface(s) (the front surface, the rear surface, or both) on which ink is applied is dried.

When only the front-surface image forming unit **111** is operated, namely when ink is applied onto only the front surface of the recording medium **10**, the front-surface heating control section **81** of the control apparatus **80-A** operates the heaters **41b**, **51b**, and **61b** so that the temperatures of the heat rollers **40b**, **50b**, and **60b** are respective setting tem-

16

peratures. Further, the heat rollers **40b**, **50b**, and **60b** heat and dry the ink only on the front surface side of the recording medium **10**.

When only the rear-surface image forming unit **112** is operated, namely when ink is applied onto only the rear surface of the recording medium **10**, the rear-surface heating control section **82** operates the heaters **41a**, **51a**, and **61a** so that the temperatures of the heat rollers **40a**, **50a**, and **60a** are respective setting temperatures. Further, the heat rollers **40a**, **50a**, and **60a** heat and dry the ink only on the rear surface side of the recording medium **10**.

Further, when both the front-surface image forming unit **111** and the rear-surface image forming unit **112** are operated, namely when ink is applied onto both surfaces of the recording medium **10**, the control apparatus **80-A** operates the heaters **41a-61b** so that the temperatures of the heat rollers **40a-60b** are respective setting temperatures. Further, the heat rollers **40a-60b** heat and dry ink on both rear and front surfaces of the recording medium **10**.

Here, when ink is applied on only the front surface or the rear surface, the control apparatus **80-A** controls the heaters **41a-61b** so that a moisture content of the recording medium **10** discharged from the ink drying apparatus (heating apparatus) **120-A** is substantially equal to the moisture content of the recording medium **10** fed from the sheet supplying apparatus **130**.

Further, when only one of the front or rear surface is dried or when the operation of the ink drying apparatus (heating apparatus) **120-A** is stopped, the control apparatus **80-A** completely turns off the heaters that are not to be operated.

Otherwise, when only one of the front or rear surface is dried, the control apparatus **80-A** may operate the heaters that are not to be operated so that the temperatures of the heat rollers on the side of the surface opposite to the surface on which ink is applied of the recording medium **10** are lower than the corresponding temperatures set in the heat rollers that are on the side of the surface on which ink is applied.

For example, the temperatures to be set on the side of the surface to which ink is applied is approximately in a range from 60° C. to 120° C. and the temperatures to be set on the side of the surface to which no ink is applied ("waiting temperature") is approximately in a range from 40° C. to 45° C. When the temperature is higher than 45° C., the recording medium **10** may be thermally deformed, and when the temperature is less than or equal to 40° C., it may not be possible to maintain a temperature-sustaining effect of the heat rollers **40a-60b**. Therefore, temperatures in the range from 40° C. to 45° C. are the optimal waiting temperatures.

The control apparatus **80-A** controls the temperatures of the heat rollers **40a-60b** based on the temperatures of the heat rollers **40a-60b** detected by the temperature sensors **42a-62b** and operating states indicating, for example, the rotational speed of the discharge feed roller **70** and/or the supply feed roller **30**.

In this case, in the control apparatus **80-A**, the rear-surface heating control section **82** collectively controls the heat rollers **40a**, **50a**, and **60a** of the respective heat roller sets as a recording medium rear-surface heat roller group.

Further, the front-surface heating control section **81** collectively controls the heat rollers **40b**, **50b**, and **60b** of the respective heat roller sets as a recording medium front-surface heat roller group. Herein the recording medium rear-surface heat roller group and the recording medium front-surface heat roller group may also be called a "one surface heat roller group" and a "the other surface heat roller group", respectively.

17

The front-surface heating control section **81** and the rear-surface heating control section **82** control respective heaters **41a-61b** in a manner such that the setting temperatures of the third rear-surface heat roller **60a** and the third front-surface heat roller **60b** disposed on the downstream side of the feeding path of the recording medium **10** are higher than the respective setting temperatures of the first rear-surface heat roller **40a** and the first front-surface heat roller **40b** disposed on the upstream side of the feeding path.

FIG. **12** is a graph illustrating the relationship between the amount of heat received by the recording medium **10** and the heat roller sets. As illustrated in FIG. **12**, the rear-surface heating control section **82** controls the heaters **41a**, **51a**, and **61a** of the heat rollers **40a**, **50a**, and **60a** so that the temperatures of the heat rollers **40a**, **50a**, and **60a** of the recording medium rear-surface heat roller group are **T4a**, **T5a**, and **T6a**, respectively.

Further, the front-surface heating control section **81** controls the heaters **41b**, **51b**, and **61b** of the heat rollers **40b**, **50b**, and **60b** so that the temperatures of the heat rollers **40b**, **50b**, and **60b** of the recording medium front-surface heat roller group are **T4b**, **T5b**, and **T6b**, respectively.

Then, the control apparatus **80-A** controls the heaters **41a-61b** so that, for example, the setting temperatures of the heat rollers **40a-60b** satisfy the following formula (1). Relationship of controlled temperatures of heat rollers **40a-60b**

$$T4a \leq T5a \leq T6a \text{ and } T4b \leq T5b \leq T6b \quad (1)$$

In this case, it is also possible that neither the recording medium rear-surface heat roller group **40a**, **50a**, and **60a** nor the recording medium front-surface heat roller group **40b**, **50b**, and **60b** is heated or both of the recording medium rear-surface heat roller group **40a**, **50a**, and **60a** and the recording medium front-surface heat roller group **40b**, **50b**, and **60b** are not heated.

Further, the control apparatus **80-A** monitors the temperatures of the heat rollers **40a-60b** and compares the differences between the setting temperatures **T4a**, **T5a**, **T6a**, **T4b**, **T5b**, and **T6b** of the heat rollers **40a-60b** and the corresponding current temperatures. Based on the comparisons, the control apparatus **80-A** controls the temperatures of the heat rollers **40a-60b** while anticipating the temperatures after a certain time period.

Otherwise, the control apparatus **80-A** may perform two-step (on/off) control by continuing to turn on the heaters **41a-61b** until the temperatures thereof reach the respective setting temperatures and turning off the heaters **41a-61b** when the temperatures thereof reach the respective setting temperatures.

The control apparatus **80-A** performs control so that an amount of heat supplied from the first rear-surface heat roller **40a** of the recording medium rear-surface heat roller group to the recording medium **10** is **W4a**, an amount of heat supplied from the second rear-surface heat roller **50a** of the recording medium rear-surface heat roller group to the recording medium **10** is **W5a**, and an amount of heat supplied from the third rear-surface heat roller **60a** of the recording medium rear-surface heat roller group to the recording medium **10** is **W6a**.

In the same manner, the control apparatus **80-A** performs control so that an amount of heat supplied from the first front-surface heat roller **40b** of the recording medium front-surface heat roller group to the recording medium **10** is **W4b**, an amount of heat supplied from the second front-surface heat roller **50b** of the recording medium front-surface heat roller group to the recording medium **10** is **W5b**, and an

18

amount of heat supplied from the third front-surface heat roller **60b** of the recording medium front-surface heat roller group to the recording medium **10** is **W6b**.

In this case, the control apparatus **80-A** controls the heaters **41a-61b** so that a total amount of heat **W** which is the sum of an amount of heat **Wa**, which corresponds to the heating the rear surface, and an amount of heat **Wb**, which corresponds to the heating the front surface, exceeds an amount of heat that is sufficient to evaporate the solvent included in the ink on the recording medium **10** at a desired degree.

$$W_a (= \text{total amount of heat } W_{4a} + W_{5a} + W_{6a}) + W_b (= \text{total amount of heat } W_{4b} + W_{5b} + W_{6b}) > \text{amount of heat sufficient to evaporate (minimum required heat for evaporation)} \quad (2)$$

Further, the amount of heat supplied from the heat rollers **40a-60b** to the recording medium varies depending on the time period while the recording medium **10** is in contact with the heat rollers **40a-60b** (i.e., feeding speed of the recording medium). Therefore, the control apparatus **80-A** changes the setting temperatures based on the rotational speed of the discharge feed roller **70** and/or the supply feed roller **30**.

The recording medium on which ink is applied by the front-surface image forming unit **111** and the rear-surface image forming unit **112** of the recording apparatus **110** is fed to the ink drying apparatus (heating apparatus) **120-A** by the supply feed roller **30**. The rear surface of the recording medium **10** fed into the ink drying apparatus (heating apparatus) **120-A** is heated by the heat rollers **40a**, **50a**, and **60a** of the recording medium rear-surface heat roller group at the temperatures **T4a**, **T5a**, and **T6a**, respectively, controlled by the rear-surface heating control section **82**.

Similarly, the front surface of the recording medium **10** fed into the ink drying apparatus (heating apparatus) **120-A** is heated by the heat rollers **40b**, **50b**, and **60b** of the recording medium front-surface heat roller group at the temperatures **T4b**, **T5b**, and **T6b**, respectively, controlled by the front-surface heating control section **81**.

Further, the solvent component of the ink printed on the recording medium **10** is evaporated in accordance with the heat applied by the first heat roller set **40** and the second heat roller set **50**. Further, due to the heat applied by the third heat roller set **60**, the solvent component of the ink printed on the recording medium **10** is further evaporated so that the solvent component is less than or equal to a corresponding predetermined value. After that, the recording medium **10** is discharged from the ink drying apparatus (heating apparatus) **120-A** by the discharge feed roller **70**.

Next, operations of the system (printing system) **100-A** are described with reference to a flowchart in FIG. **13**. In FIG. **13**, when an instruction to start printing is issued from the operation panel **91** or the personal computer (including a server or the like) **92** (step **S100**), the system (printing system) **100-A** system starts the preparations for the printing (step **S101**).

In this case, the print control section **90** recognizes (receives) the information items from the operation panel **91** or the personal computer (including a server or the like) **92**, the information items indicating the printing state, the recording medium, and the feeding of the recording medium, which are used for determining the setting temperatures of the heat rollers **40a-60b** (step **S102**). The information indicating the printing state refers to the information indicating whether the printing is single-sided printing, rear-side printing, or double-sided printing.

The information indicating the recording medium refers to the information indicating, for example, the type (e.g.,

ordinary sheet, coated sheet or the like), the width, or the weight of the recording medium. The information indicating the feeding of the recording medium refers to the information indicating, for example, the feeding speed, the feeding amounts (corresponding number of pages).

Next, the print control section 90 further recognizes the information of the recording apparatus 110 from the operation panel 91 or the personal computer (including a server or the like) 92, the information indicating whether data (image) are recorded on the recording medium 10. When data are recorded, the print control section 90 further recognizes, for example, the recording surface(s) (i.e., single-sided or double-sided, and the front surface or the rear surface in case of single-sided).

The information items recognized by the print control section 90 are classified by the control apparatus 80-A of the ink drying apparatus (heating apparatus) 120-A into two cases: one is a case of double-sided printing where it is necessary to heat both sides (i.e., the front surface and the rear surface) of the recording medium 10, and the other is a case of single-sided printing where it is necessary to heat one side of the recording medium 10 (step S103).

In the case where it is necessary to heat both surfaces of the recording medium 10, for example, the control apparatus 80-A causes the heaters 41a-61b of the heat rollers 40a-60b to operate to have the heat roller setting temperatures determined based on the printing state as shown in Table 1. By doing this, the temperatures of the ink drying apparatus (heating apparatus) 120-A are increased (step S104).

Based on the output of the temperature sensors 42a-62b, the control apparatus 80-A determines whether the heat rollers 40a-60b are heated up to the respective setting temperatures (step S105).

Further, when it is necessary to heat only one surface of the recording medium 10 in step S103, the CPU 83 of the control apparatus 80-A determines which of the recording medium rear-surface heat roller group 40a, 50a, and 60a and the recording medium front-surface heat roller group 40b, 50b, and 60b is to be heated (step S106).

Further, the control apparatus 80-A causes the heaters 41a-61b of the heat rollers 40a-60b to operate to heat in accordance with the relationship as shown in Table 1 previously determined based on the printing state and increases the temperatures of the heaters 41a-61b (ink drying apparatus (heating apparatus) 120-A) (steps S107a and S107b).

Next, based on the output of the temperature sensors 42a-62b, the control apparatus 80-A determines whether the temperatures of the heat rollers 40a-60b reach the respective setting temperatures (step S108).

Then, when the temperatures of the heat rollers 40a-60b reach the respective setting temperatures (YES in step S105 or S108), the print control section 90 drives the sheet supplying apparatus 130, the feeding section 113, the supply feed roller 30, and the discharge feed roller 70 via the feeding control section 94 to feed the recording medium 10. In this case, the front-surface image forming unit 111 and the rear-surface image forming unit 112 of the recording apparatus 110 operate to discharge ink onto the recording medium 10 to start printing operation (step S109).

Next, the control system 500 determines whether printing in the recording apparatus 110 is finished (step S110).

After printing finishes (step S111), the control system 500 determines whether the edge end of the part where ink is applied on the recording medium 10 is discharged from the ink drying apparatus (heating apparatus) 120-A (step S112). The determination whether the edge end of the part where ink is applied on the recording medium 10 is discharged

from the ink drying apparatus (heating apparatus) 120-A is made based on ink discharge timings of the front-surface image forming unit 111 and the rear-surface image forming unit 112 and the statuses of the feeding sections such as the supply feed roller 30, and the discharge feed roller 70.

For example, the determination may be made by calculating a required time period based on the feeding distance and the feeding speed of the recording medium 10 and comparing the required time period and a result of counting the time.

When the edge end of the part where ink is applied on the recording medium 10 is discharged from the outlet 79 of the ink drying apparatus (heating apparatus) 120-A, the control apparatus 80-A turns off the operating heaters 41a-61b of the heat rollers 40a-60b to stop the ink drying apparatus (heating apparatus) 120-A (step S113).

After that, the feeding control section 94 of the control system 500 stops driving the sheet supplying apparatus 130, the feeding section 113, the supply feed roller 30, and the discharge feed roller 70, so as to stop the ink drying apparatus (heating apparatus) 120-A (step S114).

Then, the print control section 90 of the control system 500 determines whether there is the next job (step S115). When there is the next job, the process goes back to step S101 to start preparing for the printing. When there is no next job, the process ends (step S116).

According to the control described above, the recording medium 10 is in contact with the first heat roller set 40 whose temperature is the first setting temperature T1 which is the lowest among the first heat roller set 40, the second heat roller set 50, and the third heat roller set 60. By doing this, it becomes possible to reduce the temperature difference between the recording medium 10 and the heat roller(s) with which the recording medium 10 is in first contact.

Accordingly, when compared with a case where the temperature of all the heat rollers is set to the third setting temperature T3 which is the highest temperature, it becomes possible to prevent a sudden temperature increase of the recording medium 10. Namely, it becomes possible for the system 100-A of the ink drying apparatus (heating apparatus) 120-A to minimize a thermal load applied to the recording medium 10. Also, it become possible for the system 100-A to reduce the occurrence of damage (i.e., wrinkles, deformation and the like) to the recording medium 10 due to the lower thermal load.

In this third embodiment as well, the third heat roller set 60 supplies heat to the recording medium 10 sufficient to evaporate moisture in ink so that the moisture in the ink is less than or equal to a corresponding predetermined value. Therefore, it becomes possible for the system 100-A to improve the printing quality of image information formed on the recording medium 10.

Further, the ink drying apparatus (heating apparatus) 120-A controls each of the heaters 41a-61b based on the type of the recording medium 10 (e.g., type of the sheet) and the printing mode (e.g., whether printing is performed on one of the front surface and the rear surface or both if the position of the image forming area differs).

By doing this, it becomes possible for the system 100-A to reduce the thermal load to the recording medium 10 when compared with the case where the same control is performed regardless of single-sided printing or double-sided printing. Further, it becomes possible to effectively prevent the occurrence of damage (e.g., wrinkles or deformation) due to thermal load to the recording medium 10, the damage likely to occur especially when the recording medium 10 is a continuous form having an arbitrary length.

Fourth Embodiment

Next, with reference to FIGS. 14 through 16, a printing system 200-A including a recording medium heating apparatus (heating unit) 350-A according to a fourth embodiment is described. FIG. 14 is an exploded view of the recording medium heating apparatus (heating unit) 350-A in its open state. The configuration of the recording medium heating apparatus (heating unit) 350-A in this embodiment is basically similar to that of the recording medium heating apparatus (heating unit) 350 according to the second embodiment except that a control apparatus 80-A is used in place of the control apparatus 80.

Further, the recording medium heating apparatus (heating unit) 350-A is used in the preprocessing apparatus (preprocessing liquid application and drying apparatus) 220 in FIG. 7 in place of the recording medium heating apparatus (heating unit) 350. Further, a preprocessing apparatus (preprocessing liquid application and drying apparatus) 220-A according to the fourth embodiment is a part of the printing system 200 of FIG. 6.

In this embodiment, a printing system 200-A and the preprocessing apparatus (preprocessing liquid application and drying apparatus) 220-A are provided. In the following, the same reference numerals are used to describe the same elements as those in the second embodiment, and the elements (parts) differs from those in the second embodiment are mainly described. Further, in this embodiment, the outline of the recording medium heating apparatus (heating unit) 350-A, the configurations of the preprocessing apparatus (preprocessing liquid application and drying apparatus) 220-A and the printing system 200-A are the same as those in the second embodiment. Therefore, the descriptions thereof are basically omitted except for referring to FIGS. 4, 6, and 7.

Similar to the third embodiment, the recording medium heating apparatus (heating unit) 350-A includes a front-surface heating unit 351 on the upper side thereof and a rear-surface heating unit 352 on the lower side thereof. The front-surface heating unit 351 includes the first front-surface heat roller 40b, the second front-surface heat roller 50b, and the third front-surface heat roller 60b. The rear-surface heating unit 352 includes the first rear-surface heat roller 40a, the second rear-surface heat roller 50a, the third rear-surface heat roller 60a, and the discharge feed roller 70.

Further, there is formed the outlet 79 of the recording medium heating apparatus (heating unit) 350-A, and there is an outlet sensor 71 disposed near the outlet 79. Further, a control apparatus 80-B and the outlet sensor 71 may be disposed in either the front-surface heating unit 351 or the rear-surface heating unit 352.

FIG. 15 is a control block diagram of the printing system 200-A according to the fourth embodiment. As illustrated in FIG. 15, the control apparatus 80-B of the recording medium heating apparatus (heating unit) 350-A is included in a control system 450 of the printing system 200-A. The control apparatus 80-B of the recording medium heating apparatus (heating unit) 350-A includes the front-surface heating control section 81, the rear-surface heating control section 82, the CPU 83, and the memory 84.

Although not being illustrated, the control apparatus 80-B further includes a RAM and a ROM storing a program to be executed for heating, an I/O (input section) which controls the input and output of an electric component such as a sensor, and an I/F (interface section) for receiving data from a print control section 90.

As the control sections of the preprocessing apparatus (preprocessing liquid application and drying apparatus) 220-

A, there are the control apparatus 80-B of the recording medium heating apparatus (heating unit) 350-A, an application control section 221 of the rear-surface application unit 33 and the front-surface application unit 34, a feeding control section 222 for controlling the feeding and the like. Further, the control system 450 includes the print control section 90 that controls the entire printing system 200-A including the preprocessing apparatus (preprocessing liquid application and drying apparatus) 220-A and the like.

In the preprocessing apparatus (preprocessing liquid application and drying apparatus) 220-A, the application control section 221 is connected to the rear-surface application unit 33 and the front-surface application unit 34 to control the rear-surface application unit 33 and the front-surface application unit 34. The feeding control section 222 is connected to the outfeed roller 335, the feed roller 359, the dancer unit 380, the air loop unit 320 and the like to control feeding of the recording medium 10.

Further, the control system 450 is connected to the printing system 200-A including the preprocessing apparatus (preprocessing liquid application and drying apparatus) 220-A and includes the print control section 90 that controls the entire printing system 200-A and the like. The print control section 90 is connected to the operation panel 91, the personal computer (including a server or the like) 92, the sheet supplying apparatus 210, the first inkjet printer 230, the second inkjet printer 250, the post drying apparatus 260, and the winding apparatus 270 via plural data lines and the like. The print control section 90 performs general control on the image forming processes including a process of drying preprocessing liquid.

The control apparatus 80-B of the recording medium heating apparatus (heating unit) 350-A includes the front-surface heating control section 81, the rear-surface heating control section 82, the CPU 83, and the memory 84 and the like. Based on the information acquired from the connected application control section 221, the feeding control section 222, the print control section 90 and the like, the CPU 83 controls the front-surface heating control section 81 and the rear-surface heating control section 82.

The control apparatus 80-B controls the temperatures of the heat rollers 40a-60b based on actuated conditions including, for example, the temperatures of the heat rollers 40a-60b detected by the temperature sensors 42a-62b and the rotational speed of the feed roller 359 for discharging and/or the outfeed roller 335 for supplying.

The rear-surface heating control section 82 collectively controls the first rear-surface heat roller 40a, the second rear-surface heat roller 50a, and the third rear-surface heat roller 60a in the respective roller sets as the recording medium rear-surface heat roller group. Further, the front-surface heating control section 81 collectively controls the first front-surface heat roller 40b, the second front-surface heat roller 50b, and the third front-surface heat roller 60b in the respective roller sets as the recording medium front-surface heat roller group.

In this embodiment, to dry the applied preprocessing liquid, the front-surface heating control section 81 and the rear-surface heating control section 82 perform the heat control similar to the control that is performed on the rear-surface application unit 33 and the front-surface application unit 34, and the front-surface image forming unit 111 and the rear-surface image forming unit 112 in the third embodiment.

A detailed control method in the embodiment is similar to that in the third embodiment described with reference to FIG. 12. Therefore, the repeated description thereof is omitted.

Further, in the third embodiment, it is ink that is evaporated. In the fourth embodiment, it is the solvent of the preprocessing liquid that is to be evaporated. However, the temperature setting method in this embodiment is substantially the same as that described above. Namely, the control is performed based on the flow described below based on Formula (1) above and the controlled values as shown in FIG. 12.

Next, the operations of the printing system 200-A are described with reference to the flowchart in FIG. 16. FIG. 16 is a flowchart illustrating the control performed in the printing system 200-A. As illustrated in FIG. 16, when an instruction to start printing is issued from the operation panel 91 or the personal computer (including a server or the like) 92 (step S200), the printing system 200-A system starts the preparations for printing by the print control section 90 (step S210).

In this case, the print control section 90 recognizes (receives) the information items from the operation panel 91 or the personal computer (including a server or the like) 92, the information items indicating the printing state, the recording medium, and the feeding of the recording medium, which are used for determining the setting temperatures of the heat rollers 40a-60b (step S220). The information indicating the printing state refers to the information indicating whether the printing is single-sided printing, rear-side printing, or double-sided printing.

The information indicating the recording medium refers to the information indicating, for example, the type (e.g., ordinary sheet, coated sheet or the like), the width, the weight of the recording medium. The information indicating feeding of the recording medium refers to the information indicating, for example, the feeding speed, the feeding amounts (corresponding number of pages).

Next, the print control section 90 further recognizes the information of the first inkjet printer 230 and the second inkjet printer 250 from the operation panel 91 or the personal computer (including a server or the like) 92, the information indicating whether data (image) are recorded on the recording medium 10. When data are recorded, the print control section 90 further recognizes, for example, the recording surface(s) (i.e., single-sided or double-sided, and the front surface or the rear surface in case of single-sided).

The information items recognized by the print control section 90 are classified by the control apparatus 80-B of the recording medium heating apparatus (heating unit) 350-A into two cases: one is a case of double-sided printing where it is necessary to heat both sides (i.e., the front surface and the rear surface) of the recording medium 10, and the other is a case of single-sided printing where it is necessary to heat one side of the recording medium 10 (step S230).

In the case where it is necessary to heat both surfaces of the recording medium 10, for example, the control apparatus 80-B causes the heaters 41a-61b of the heat rollers 40a-60b to operate to have the heat roller setting temperatures determined based on the printing state as shown in Table 1. By doing this, the temperatures of the recording medium heating apparatus (heating unit) 350-A, which is the drying section of the preprocessing apparatus (preprocessing liquid application and drying apparatus) 220-A for drying the preprocessing liquid of the are increased (step S240).

Based on the output of the temperature sensors 42a-62b, the control apparatus 80-B of the recording medium heating

apparatus (heating unit) 350-A determines whether the heat rollers 40a-60b are heated up to the respective setting temperatures (step S250).

Further, when it is necessary to heat only one surface of the recording medium 10 in step S230, the CPU 83 of the control apparatus 80-B determines which of the recording medium rear-surface heat roller group 40a, 50a, and 60a and the recording medium front-surface heat roller group 40b, 50b, and 60b are to be heated (step S260).

Further, in the heat rollers 40a-60b in the recording medium rear-surface heat roller group and the recording medium front-surface heat roller group, for example, the control apparatus 80-B causes the heaters 41a-61b of the heat rollers 40a-60b to operate to heat in accordance with the relationship as shown in Table 1 previously determined based on the printing state. By doing this, the temperatures of the control apparatus 80-B of the recording medium heating apparatus (heating unit) 350-A, which is the drying section of the preprocessing apparatus (preprocessing liquid application and drying apparatus) 220-A, is increased (steps S270a and S270b).

Next, based on the output of the temperature sensors 42a-62b, the control apparatus 80-B determines whether the temperatures of the heat rollers 40a-60b reach the respective setting temperatures (step S280).

Then, when the temperatures of the heat rollers 40a-60b reach the respective setting temperatures (YES in step S250 or S280), the feeding control section 222 and the like drive the sheet supplying apparatus 210, the feed-in (FI) roller 322, the infeed roller 331, the outfeed roller 335, and the pressing roller 339 to feed the recording medium 10. At the same time, the feeding control section 222 operates the preprocessing liquid application apparatus (preprocessing liquid application unit) 330 to apply the preprocessing liquid onto the recording medium 10 (step S290).

The control apparatus 80-B determines whether the part (the edge end of the part) where the preprocessing liquid is applied onto the recording medium 10 reaches an inkjet head section (image forming section) 231 of the first inkjet printer 230 (step S300).

The determination whether the edge end of the part where the preprocessing liquid is applied onto the recording medium 10 reaches the inkjet head section (image forming section) 231 is made based on the discharge timings of the preprocessing liquid, the feeding amount of the outfeed roller 335, the feed roller 359, and the guide roller 382, the position of the movable frame 384 and the like. For example, the determination may be made by calculating a required time period based on the feeding distance and the feeding speed of the recording medium 10 and comparing the required time period and a result of counting the time.

When the edge end of the part where the preprocessing liquid is applied onto the recording medium 10 reaches the inkjet head section (image forming section) 231 of the first inkjet printer 230, the print control section 90 of the control system 450 operates the first inkjet printer 230 to start printing (step S310).

Similarly, when the edge end of the part where the preprocessing liquid is applied onto the recording medium 10 reaches the inkjet head section (image forming section) 251 of the second inkjet printer 250, the print control section 90 of the control system 450 operates the second inkjet printer 250.

Next, the print control section 90 of the control system 450 determines whether printing is finished (step S320).

When printing is finished, the application control section 221 of the control system 450 stops the application of the

25

preprocessing liquid by the preprocessing liquid application apparatus (preprocessing liquid application unit) **330** (step **S330**).

Then, the control apparatus **80-B** of the control system **450** determines whether the edge end of the part where the preprocessing liquid is applied on the recording medium **10** is discharged from the recording medium heating apparatus (heating unit) **350-A** (step **S340**). The determination whether the edge end of the part where the preprocessing liquid is applied on the recording medium **10** is discharged from the recording medium heating apparatus (heating unit) **350-A** is made based on the discharge timings of the preprocessing liquid, the feeding amount of the outfeed roller **335**, the feed roller **359**, and the guide roller **382**, the position of the movable frame **384** and the like.

For example, the determination may be made by calculating a required time period based on the feeding distance and the feeding speed of the recording medium **10** and comparing the required time period and a result of counting the time.

When the edge end of the part where the preprocessing liquid is applied onto the recording medium **10** is discharged from the recording medium heating apparatus (heating unit) **350-A**, the front-surface heating control section **81** and the rear-surface heating control section **82** turn off the operating heaters **41a-61b** of the heat rollers **40a-60b**, and the control apparatus **80-B** stops the operation of the recording medium heating apparatus (heating unit) **350-A** (step **S350**).

After that, the print control section **90** of the control system **450** stops feeding the recording medium **10** via the feeding control section **222** of the preprocessing apparatus (preprocessing liquid application and drying apparatus) **220-A**, and the feeding control section **94** for another feeding section **355** and the discharge feed roller **70** (step **S360**).

Then, the control system **450** determines whether there is the next job (step **S370**). When there is the next job, the process goes back to step **S210** to start preparing for printing. When there is no next job, the process ends (step **S380**).

According to the control described above, the recording medium **10** is in contact with the first heat roller set **40** whose temperature is the first setting temperature **T1** that is the lowest among the first heat roller set **40**, the second heat roller set **50**, and the third heat roller set **60**.

By doing this, it becomes possible to reduce the temperature difference between the recording medium **10** and the heat roller(s) with which the recording medium **10** is in first contact. Accordingly, when compared with a case where the temperature of all the heat rollers is set to the third setting temperature **T3** which is the highest temperature, it becomes possible to prevent a sudden temperature increase of the recording medium **10**.

Namely, it becomes possible for the system **200-A** including the preprocessing apparatus (preprocessing liquid application and drying apparatus) **220-A** having the recording medium heating apparatus (heating unit) **350-A** to minimize a thermal load applied to the recording medium **10**. Also, it becomes possible for the system **200-A** to reduce the occurrence of damage (i.e., wrinkles, deformation and the like) to the recording medium **10** due to the lower thermal load.

In this fourth embodiment, the third heat roller set **60** supplies sufficient heat to the recording medium **10** to evaporate the solvent in the preprocessing liquid so that the solvent in the preprocessing liquid is less than or equal to a corresponding predetermined value. Therefore, it becomes

26

possible for the system **200-A** to improve the printing quality of image information formed on the recording medium **10**.

Further, the control apparatus **80-B** controls each of the heaters **41a-61b** based on the type of the recording medium **10** (e.g., type of the sheet) and the printing mode (e.g., whether the printing is performed on one of the front surface and the rear surface or both if the position of the image forming area differs). By doing this, it becomes possible for the system **200-A** to reduce the thermal load to the recording medium **10** when compared with the case where the same control is performed regardless of single-sided printing or double-sided printing.

Further, it becomes possible to effectively prevent the occurrence of damage (e.g., wrinkles or deformation) due to thermal load to the recording medium **10**, the damage likely to occur especially when the recording medium **10** is a continuous form having an arbitrary length.

In the above first, second, third, and fourth embodiments, a case is described where the systems **100**, **200**, **100-A**, and **200-A** include three heat roller sets **40**, **50**, and **60**. However, the number of the heat roller sets may be two or four or more.

Further, in the above first and second embodiments, a case is described where each of the heat roller sets includes two heat rollers. However, the number of heat rollers in the heat roller set may be three or more. Further, the number of the heat rollers may be separately determined among the heat roller sets.

As described above, according to an embodiment, it may become possible to heat the recording medium without causing damage to the recording medium **10**.

Although the invention has been described with respect to specific embodiments for a complete and clear disclosure, the appended claims are not to be thus limited but are to be construed as embodying all modifications and alternative constructions that may occur to one skilled in the art that fairly fall within the basic teaching herein set forth.

What is claimed is:

1. A recording medium heating apparatus, comprising:
 - a plurality of heat roller sets disposed in a feeding path of a recording medium, wherein each of the heat roller sets includes a first heat roller having a heating unit and a second heat roller having a heating unit; and
 - a control circuit configured to control temperatures of the heating units so that an average temperature of a first heat roller set is lower than an average temperature of a second heat roller set, and the first heat roller and the second heat roller of each of the first and second heat roller sets are controlled to have different temperatures.
2. A system, comprising:
 - the recording medium heating apparatus according to claim 1; and
 - a recording apparatus disposed on an upstream side of the recording medium heating apparatus in the feeding path of the recording medium and configured to adhere ink to the recording medium.
3. A system, comprising:
 - the recording medium heating apparatus according to claim 1; and
 - a preprocessing apparatus disposed on an upstream side of the recording medium heating apparatus in the feeding path of the recording medium and configured to apply preprocessing liquid to the recording medium.
4. A recording medium heating apparatus, comprising:
 - a plurality of heat roller sets disposed in a feeding path of a recording medium, wherein each of the heat roller

27

sets includes a heat roller having a heating unit and being in contact with one surface of the recording medium and another heat roller having a heating unit and being in contact with another surface of the recording medium; and

a control circuit configured to control temperatures of both of the heating units in each heat roller set so that the temperature of each of the heat rollers of a first heat roller set is lower than the temperature of each of the heat rollers in a second heat roller set, and the temperature of each of the heat rollers of the second heat roller set is lower than the temperature of each of the heat rollers in a third heat roller set, wherein the first, the second, and the third heat roller sets are included in the plurality of heat roller sets and the first heat roller set is disposed on the upstream side of the second heat roller set and the second heat roller set is disposed on the upstream side of the third heat roller set in the feeding path.

5. The recording medium heating apparatus according to claim 4, wherein the heat rollers are arranged in a zigzag manner.

6. The recording medium heating apparatus according to claim 5, wherein the heat rollers arranged in the zigzag manner are included in either a one-surface heat roller group or an another-surface heat roller group, the one-surface heat roller group including the heat rollers that are to be in contact with the one surface of the recording medium, the another-surface heat roller group including the heat rollers that are to be in contact with the another surface of the recording medium, and wherein the control unit is configured to control temperatures of the heating units so that the temperature of the heating units of the one-surface heat roller group is different from the temperatures of the heating units of the another-surface heat roller group.

7. A system, comprising:
the recording medium heating apparatus according to claim 6; and
a recording apparatus disposed on an upstream side of the recording medium heating apparatus in the feeding path of the recording medium and configured to adhere ink to the recording medium.

8. A system, comprising:
the recording medium heating apparatus according to claim 6; and
a preprocessing apparatus disposed on an upstream side of the recording medium heating apparatus in the feeding

28

path of the recording medium and configured to apply preprocessing liquid to the recording medium.

9. A system, comprising:
the recording medium heating apparatus according to claim 5; and
a recording apparatus disposed on an upstream side of the recording medium heating apparatus in the feeding path of the recording medium and configured to adhere ink to the recording medium.

10. A system, comprising:
the recording medium heating apparatus according to claim 5; and
a preprocessing apparatus disposed on an upstream side of the recording medium heating apparatus in the feeding path of the recording medium and configured to apply preprocessing liquid to the recording medium.

11. A system, comprising:
the recording medium heating apparatus according to claim 4; and
a recording apparatus disposed on an upstream side of the recording medium heating apparatus in the feeding path of the recording medium and configured to adhere ink to the recording medium.

12. A system, comprising:
the recording medium heating apparatus according to claim 4; and
a preprocessing apparatus disposed on an upstream side of the recording medium heating apparatus in the feeding path of the recording medium and configured to apply preprocessing liquid to the recording medium.

13. A recording medium heating apparatus, comprising:
a plurality of heat roller sets disposed in a feeding path of a recording medium, wherein each of the heat roller sets includes a first heat roller having a heating unit and being in contact with one surface of the recording medium and second heat roller having a heating unit and being in contact with another surface of the recording medium; and
a control circuit configured to control temperatures of both of the heating units in each heat roller set so that either all of the first heat rollers or all of the second heat rollers of each heat roller set are set to temperatures that increase in the order of a first heat roller set, a second heat roller set, and a third heat roller set, wherein the first, second, and third heat roller sets are included in the plurality of heat roller sets.

* * * * *