



US009532674B2

(12) **United States Patent**
Dennison et al.

(10) **Patent No.:** **US 9,532,674 B2**
(45) **Date of Patent:** ***Jan. 3, 2017**

(54) **METHOD AND APPARATUS FOR DISPOSABLE GLOVE DISPENSING**

(58) **Field of Classification Search**

CPC .. A41D 2400/44; A41D 19/00; A47G 25/904; A61B 19/045; B65D 83/0894

(Continued)

(71) Applicant: **No Touch Easy Gloves, Inc.**, Houston, TX (US)

(72) Inventors: **Jack Brian Dennison**, Houston, TX (US); **John Owensby**, Cary, NC (US); **Brad Forrest**, Cary, NC (US); **Steve Knight**, Spring, TX (US)

(56) **References Cited**

U.S. PATENT DOCUMENTS

3,468,100 A * 9/1969 Rubel B65B 43/34
53/385.1
4,863,084 A * 9/1989 Nabozny A41D 19/0068
2/161.6

(Continued)

(73) Assignee: **NO TOUCH EASY GLOVES, INC.**, Houston, TX (US)

(*) Notice: Subject to any disclaimer, the term of this patent is extended or adjusted under 35 U.S.C. 154(b) by 0 days.

This patent is subject to a terminal disclaimer.

Primary Examiner — Patrick Mackey

(74) *Attorney, Agent, or Firm* — Snell & Wilmer L.L.P.

(21) Appl. No.: **14/699,958**

(57) **ABSTRACT**

(22) Filed: **Apr. 29, 2015**

A disposable glove dispensing system may allow for a user to efficiently put on a disposable glove without touching the outside of the glove. In various embodiments, a disposable glove may comprise an opening for hand entry having a first opening edge and a second opening edge, a first interconnection point located near the first opening edge, where the first interconnection point attaches the disposable glove to a first adjacent disposable glove, and a second interconnection point located near the second opening edge. The second interconnection point may attach the disposable glove to a second adjacent disposable glove, wherein the disposable glove is positioned between the first adjacent disposable glove and the second adjacent disposable glove. Furthermore, a disposable glove dispensing system may comprise a pack of interconnected disposable gloves, and a glove dispenser comprising two glove hangers for hanging the pack of disposable gloves hang.

(65) **Prior Publication Data**

US 2015/0230645 A1 Aug. 20, 2015

Related U.S. Application Data

(63) Continuation of application No. 14/332,119, filed on Jul. 15, 2014, now Pat. No. 9,078,647, which is a (Continued)

(51) **Int. Cl.**

A41D 19/00 (2006.01)

A47G 25/90 (2006.01)

(Continued)

(52) **U.S. Cl.**

CPC *A47G 25/904* (2013.01); *A41D 19/00* (2013.01); *A61B 19/045* (2013.01); *B65D 83/0894* (2013.01); *A61B 2019/046* (2013.01)

27 Claims, 29 Drawing Sheets

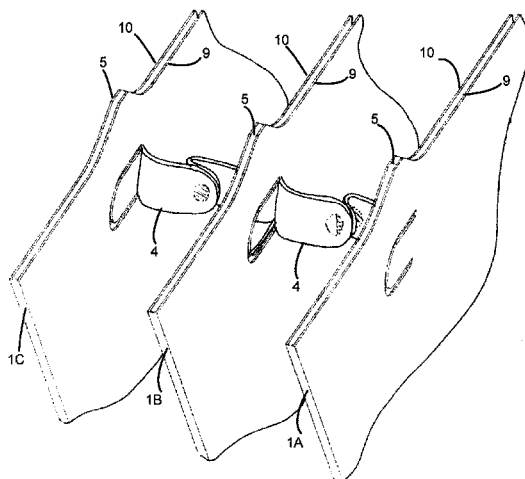

Related U.S. Application Data

- continuation of application No. 14/331,061, filed on Jul. 14, 2014, now Pat. No. 8,960,493.
- (60) Provisional application No. 61/870,223, filed on Aug. 26, 2013.
- (51) **Int. Cl.**
A61B 19/04 (2006.01)
B65D 83/08 (2006.01)
- (58) **Field of Classification Search**
 USPC 221/33, 45, 46, 179, 282, 283; 2/159, 2/161.6, 161.7
 See application file for complete search history.

5,655,682 A * 8/1997 Hoffrichter B65D 83/0805
 206/554

5,806,099 A * 9/1998 Grinberg A41D 19/0068
 2/158

5,845,779 A * 12/1998 Wilfong, Jr. B65D 33/14
 206/554

5,966,741 A * 10/1999 Klecina A41D 19/0068
 2/159

6,142,302 A * 11/2000 Requena B31B 19/62
 206/554

6,497,340 B2 * 12/2002 Grinberg A41D 19/0072
 2/158

6,578,728 B1 * 6/2003 Weigen A47K 10/38
 221/135

6,708,840 B2 * 3/2004 Grinberg A41D 19/0072
 2/159

6,955,276 B2 * 10/2005 Grinberg A41D 19/0072
 2/159

8,210,354 B2 * 7/2012 Alvarado A47F 13/085
 206/554

8,550,314 B2 * 10/2013 Kelly A61B 42/50
 223/111

2006/0049199 A1 * 3/2006 West A61B 19/045
 221/26

2007/0094766 A1 * 5/2007 Liu A41D 19/0072
 2/159

(56) **References Cited**

U.S. PATENT DOCUMENTS

RE33,264 E * 7/1990 Baxley B65D 33/001
 206/554

4,942,992 A * 7/1990 Fischer 224/240

5,020,750 A * 6/1991 Vrooman A47F 9/042
 248/97

5,335,788 A * 8/1994 Beasley B65D 33/001
 206/554

* cited by examiner

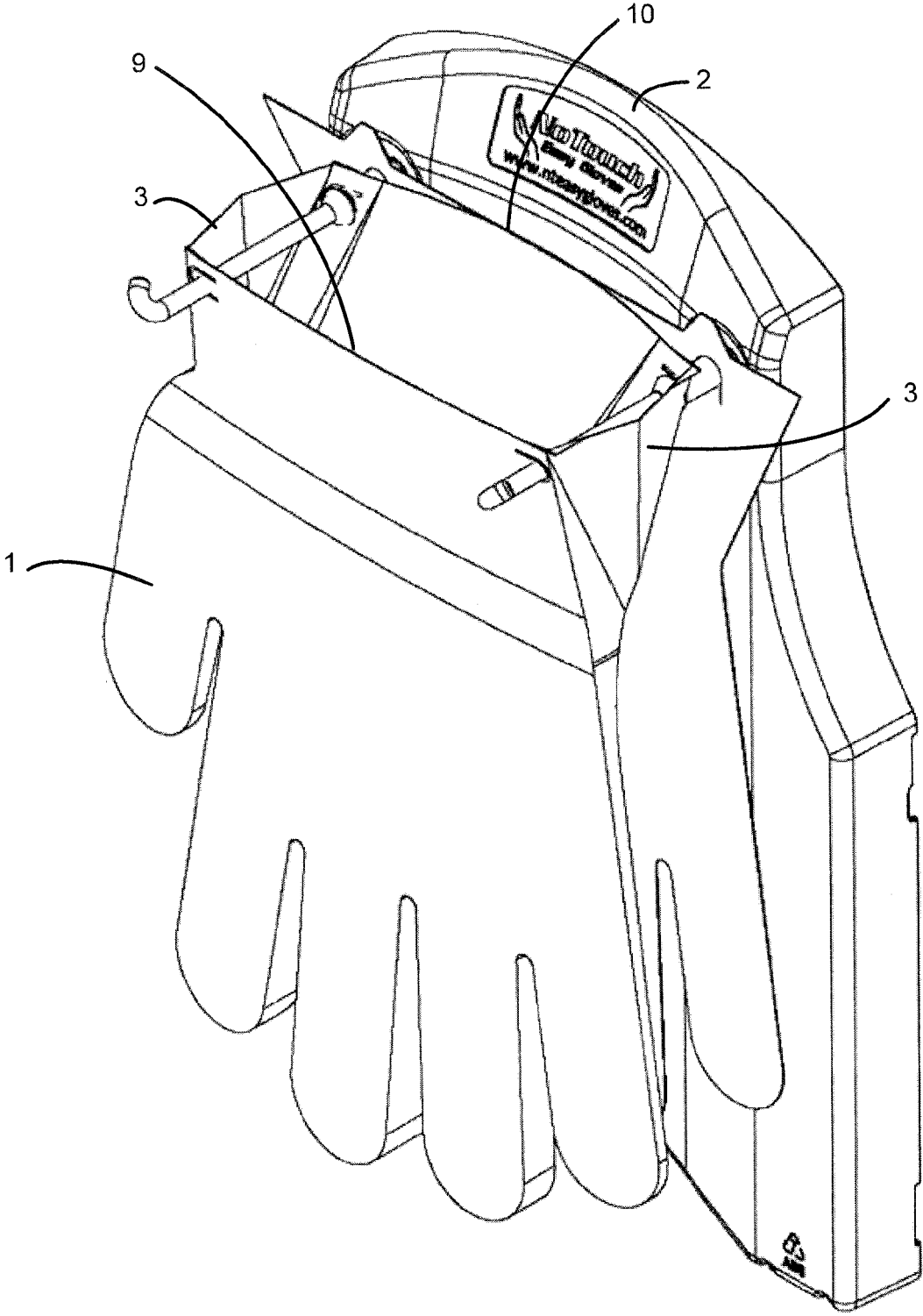

FIG. 1

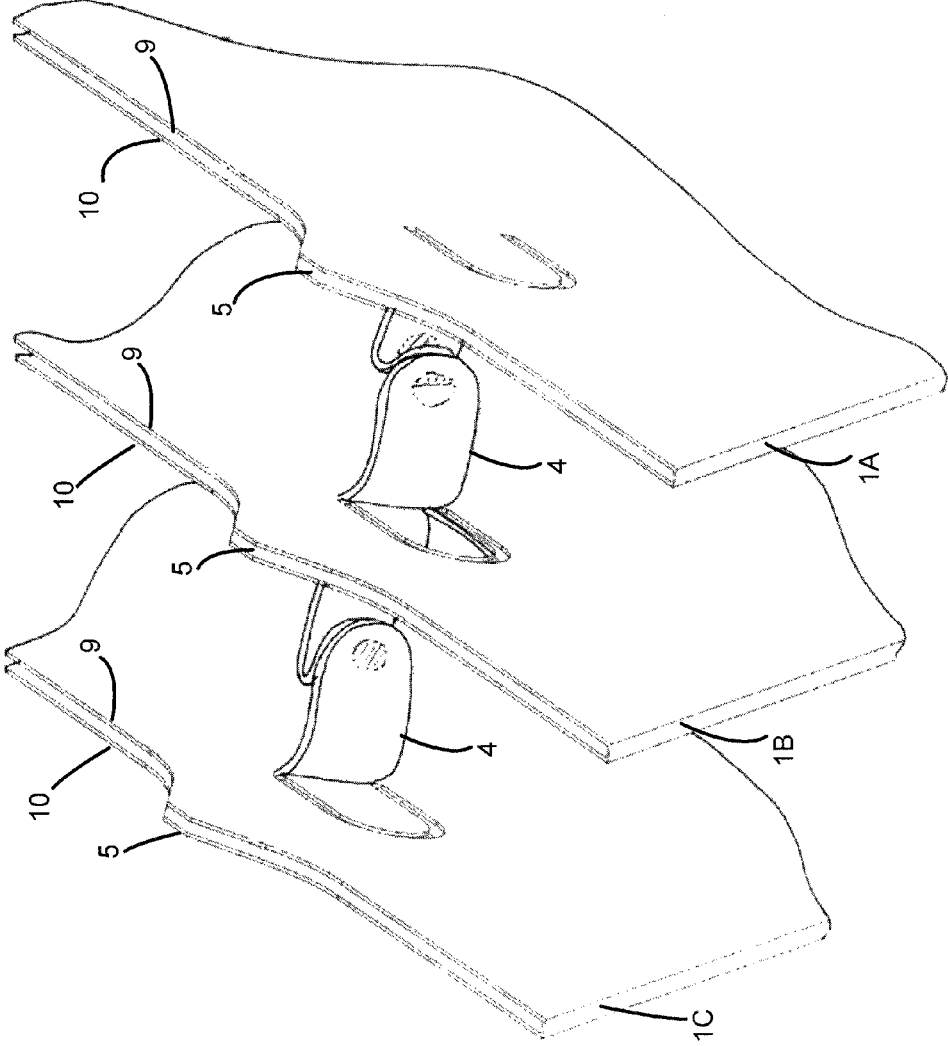

FIG. 2

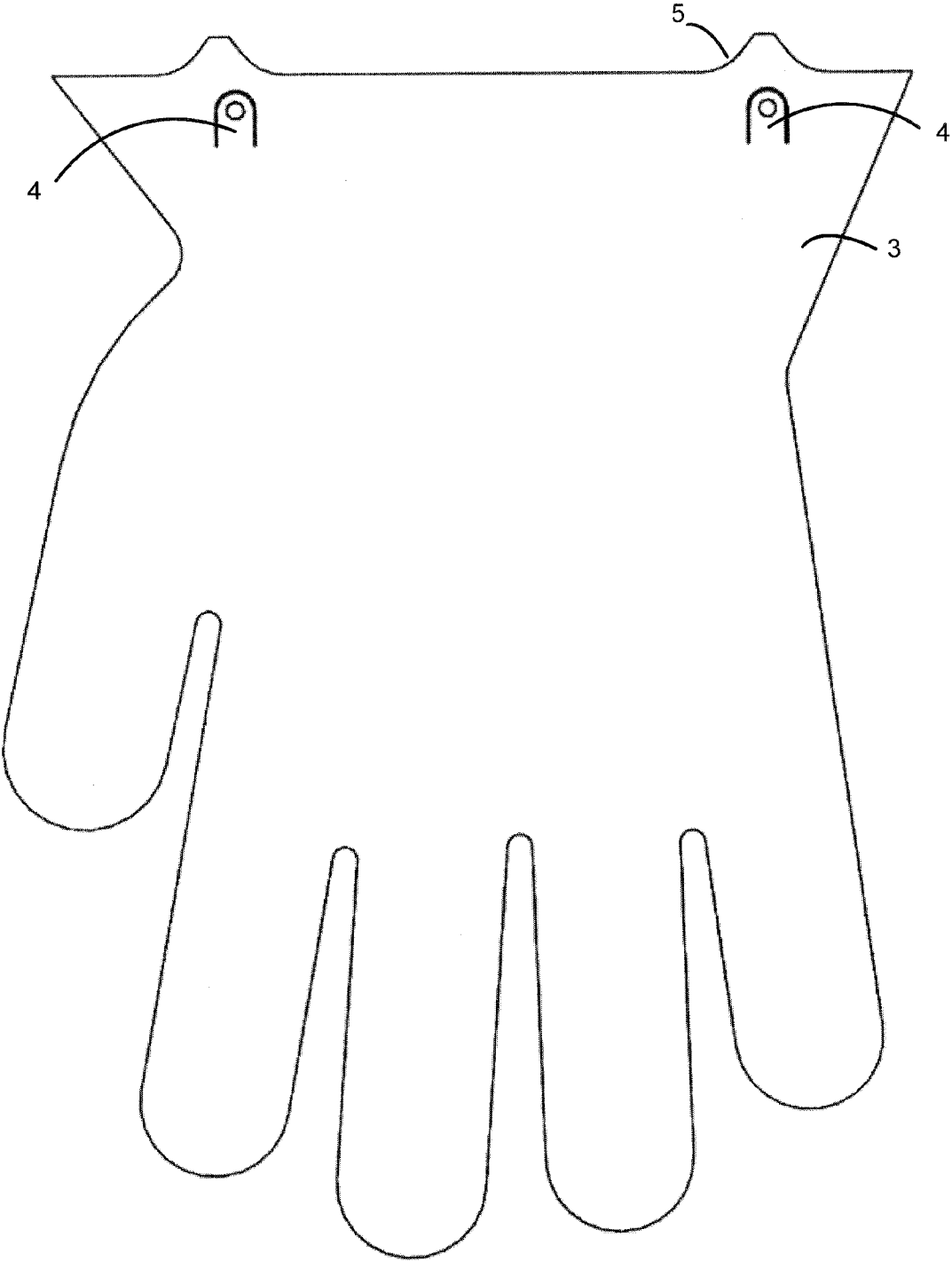

FIG. 3A

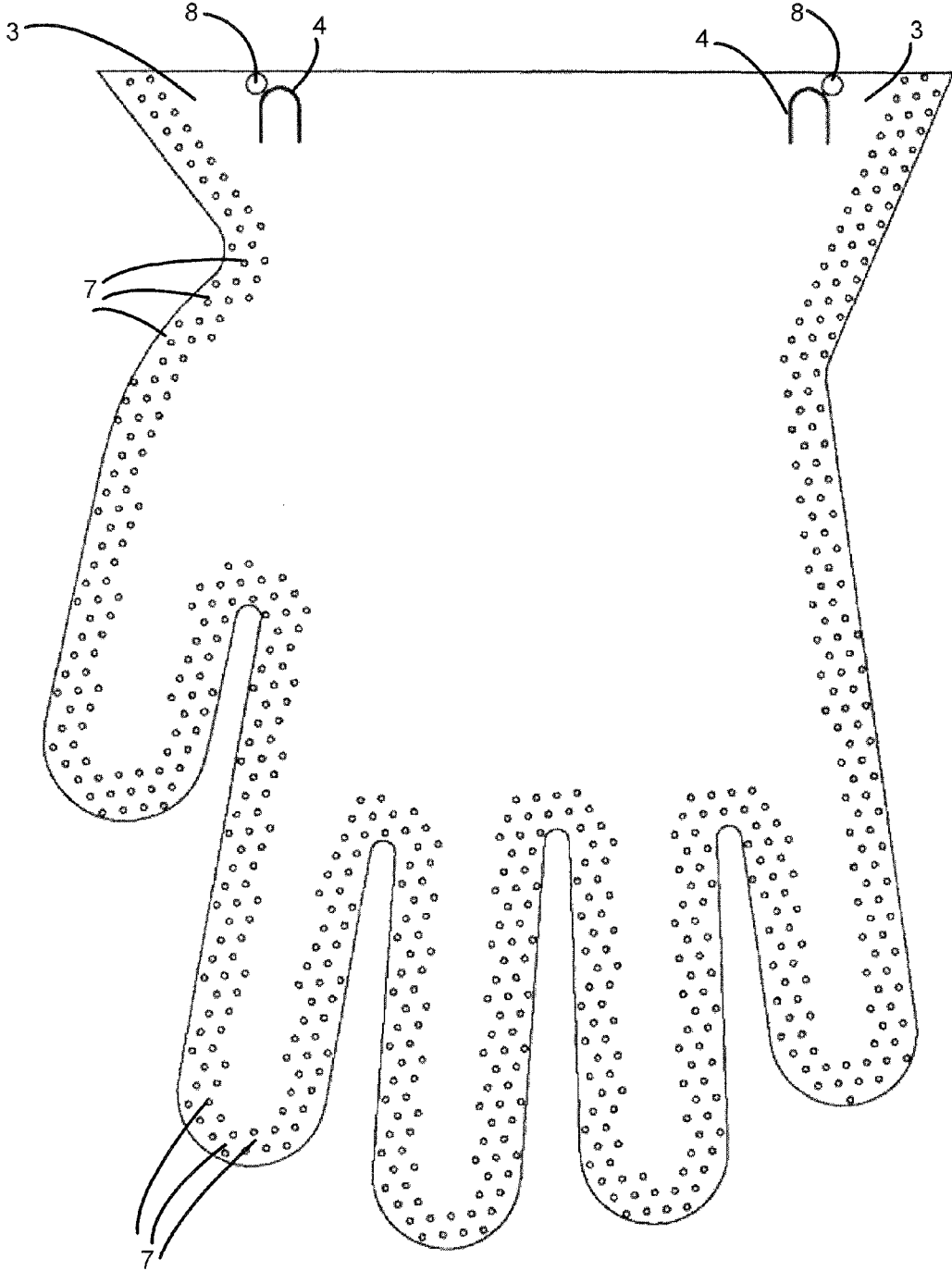

FIG. 3B

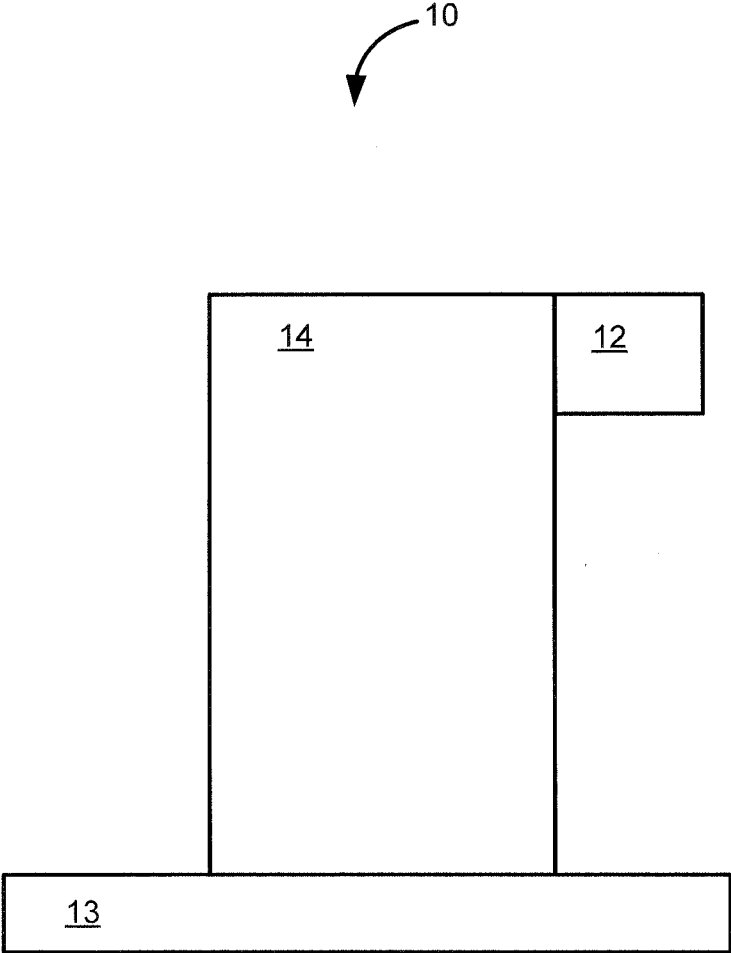

FIG. 4

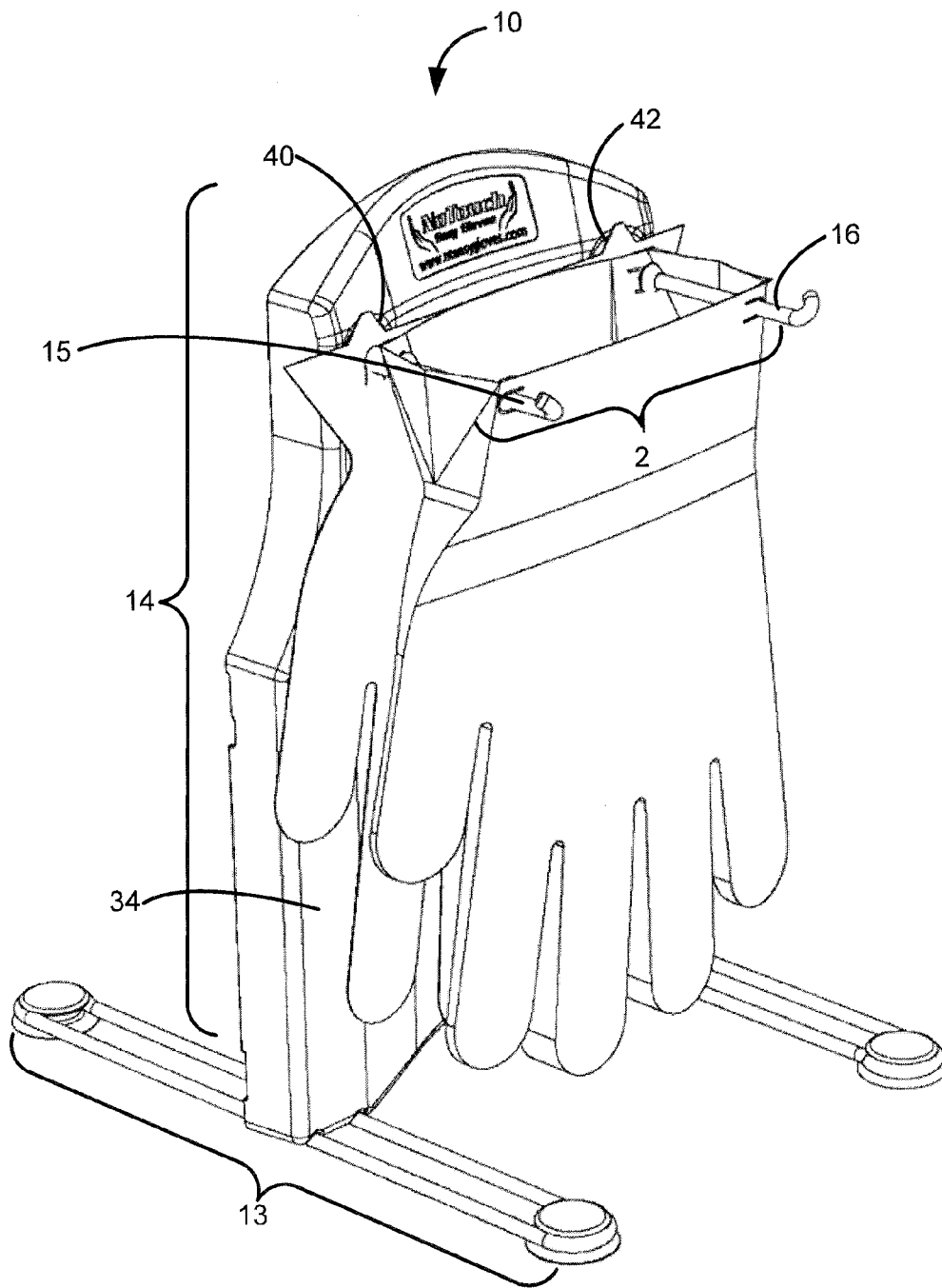

FIG. 5A

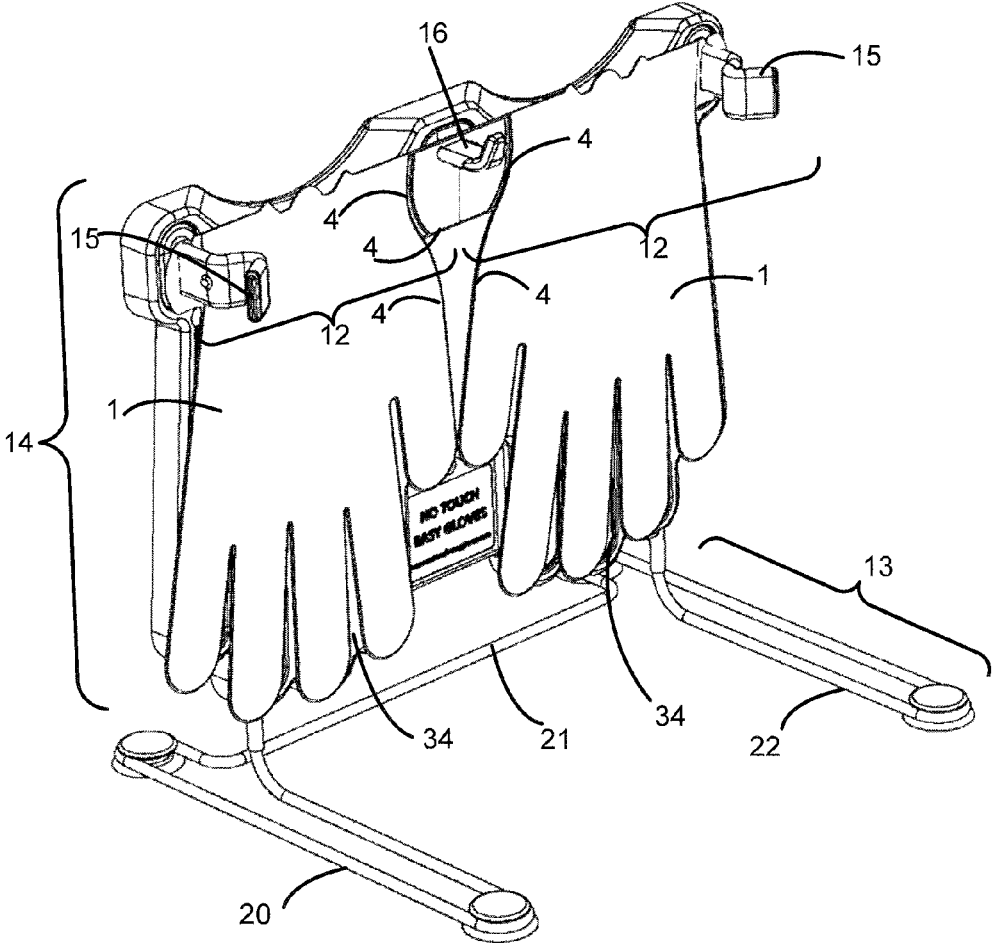

FIG. 5B

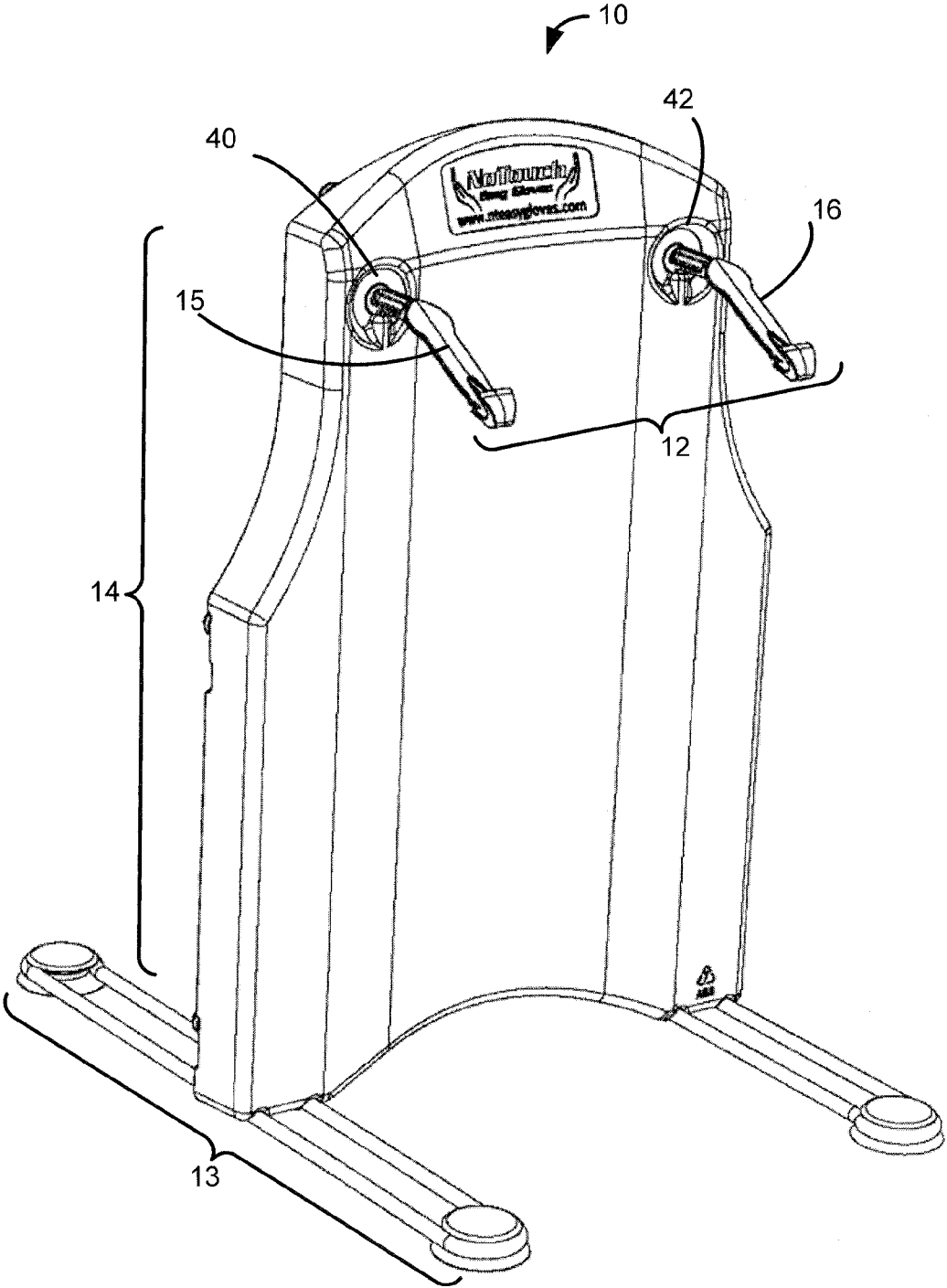

FIG. 5C

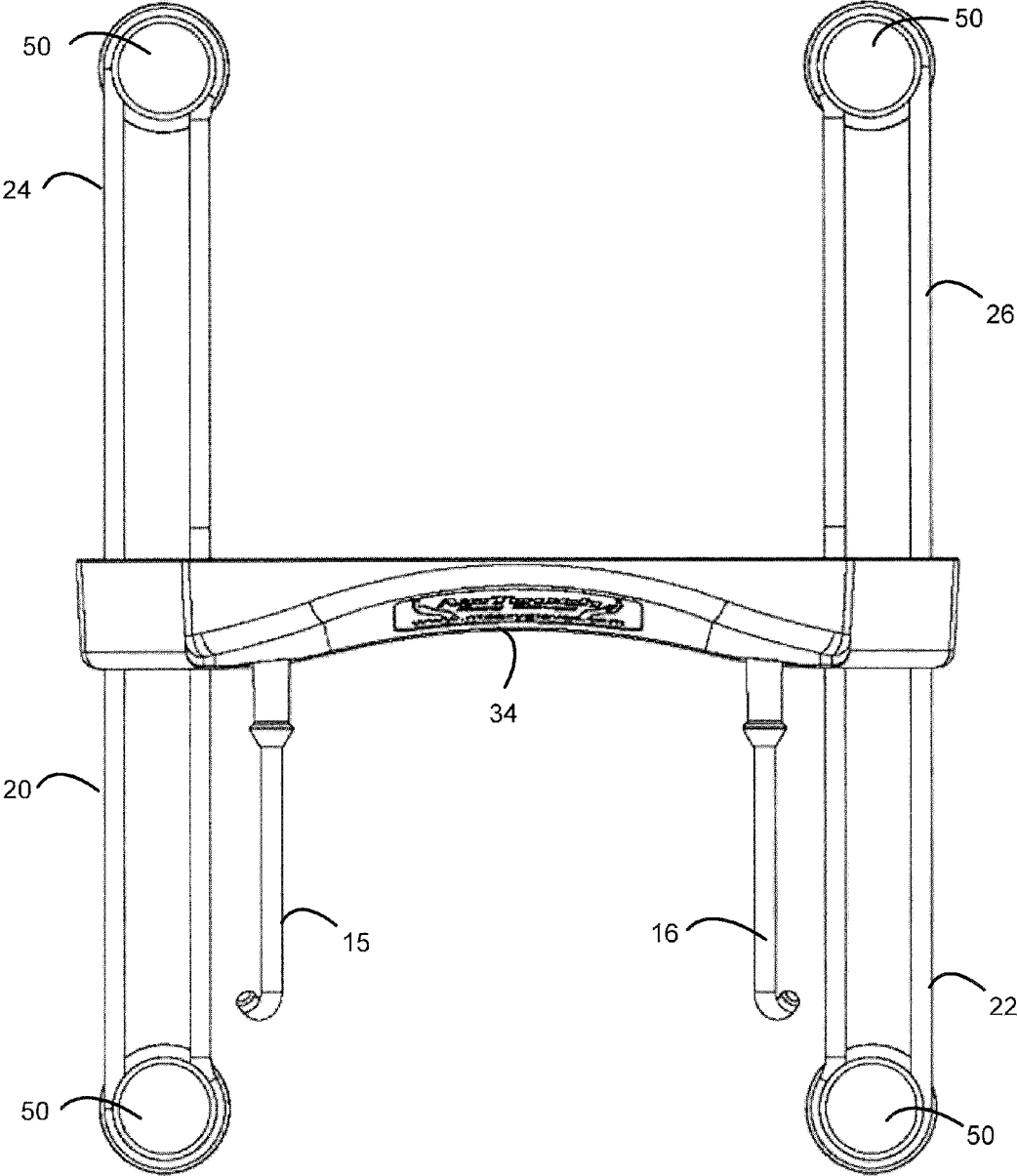

FIG. 6A

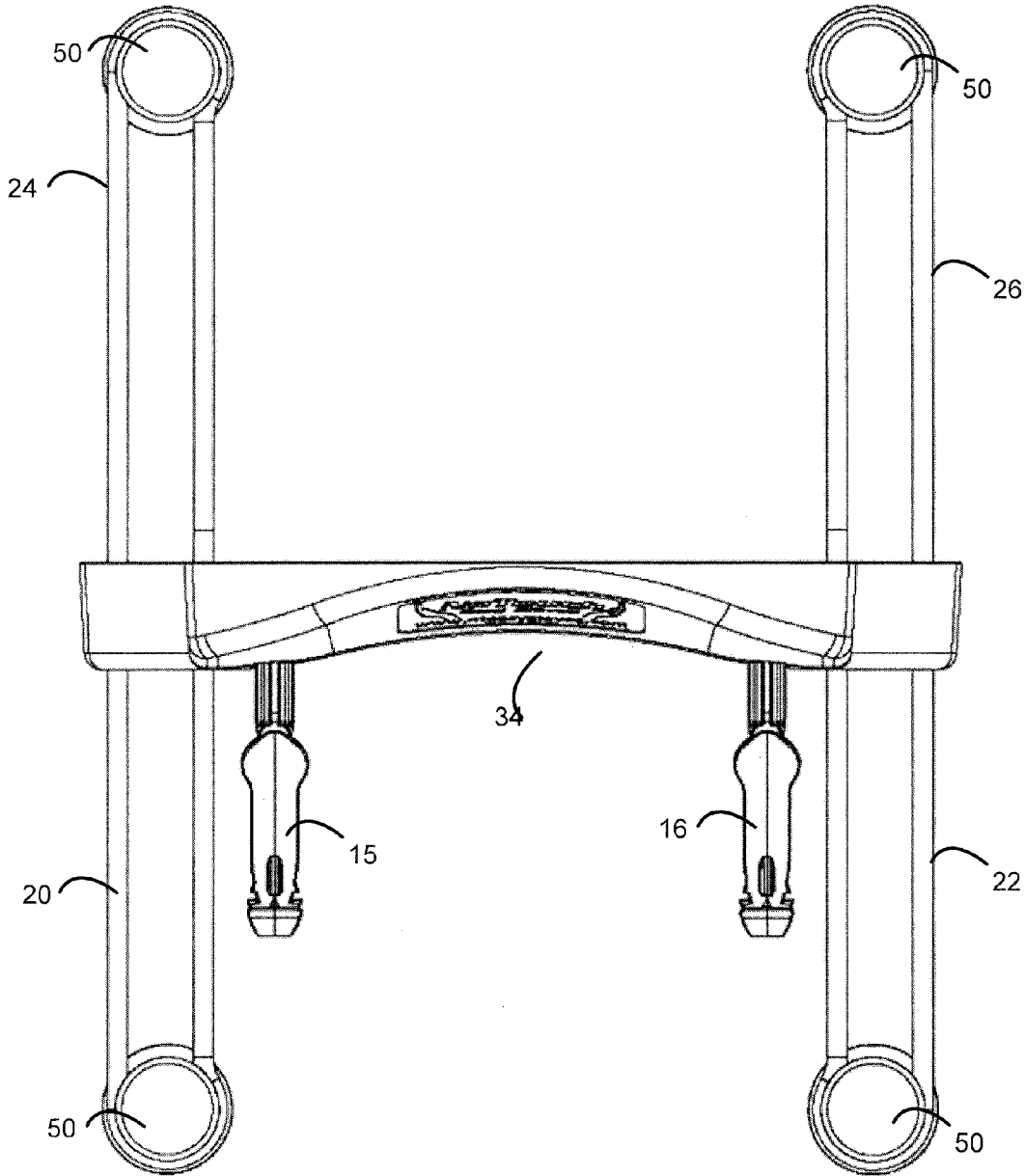

FIG. 6B

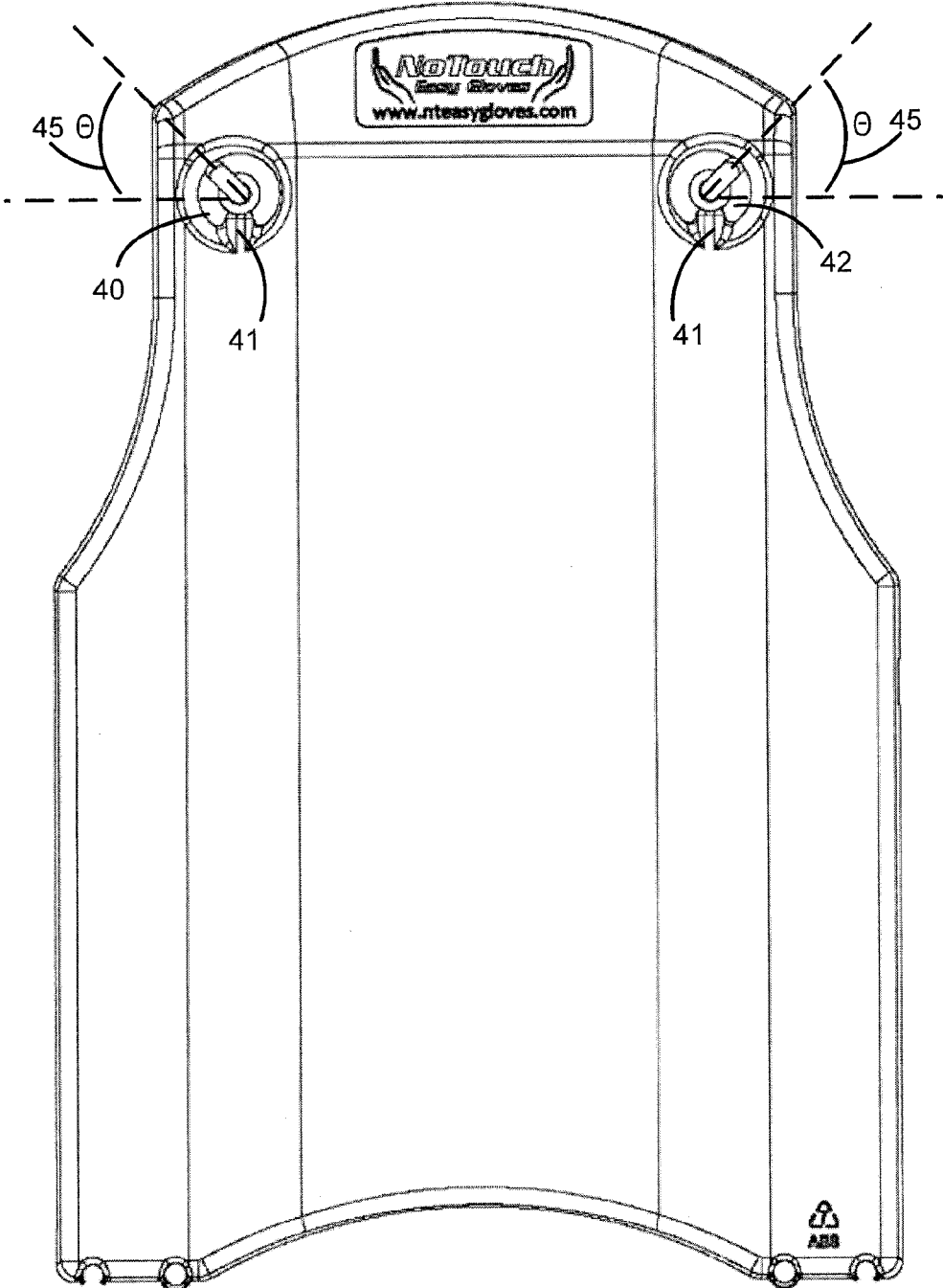

FIG. 7A

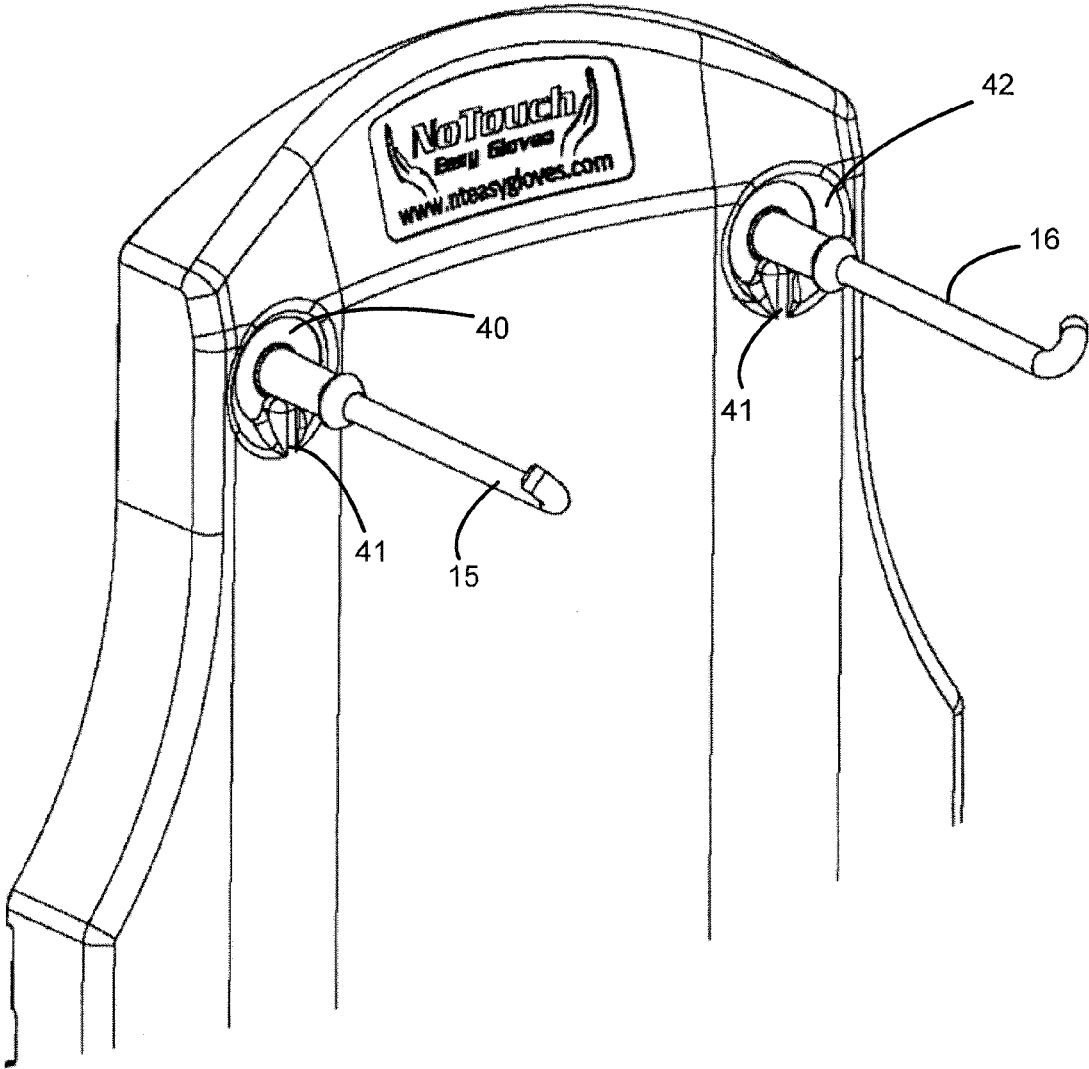

FIG. 7B

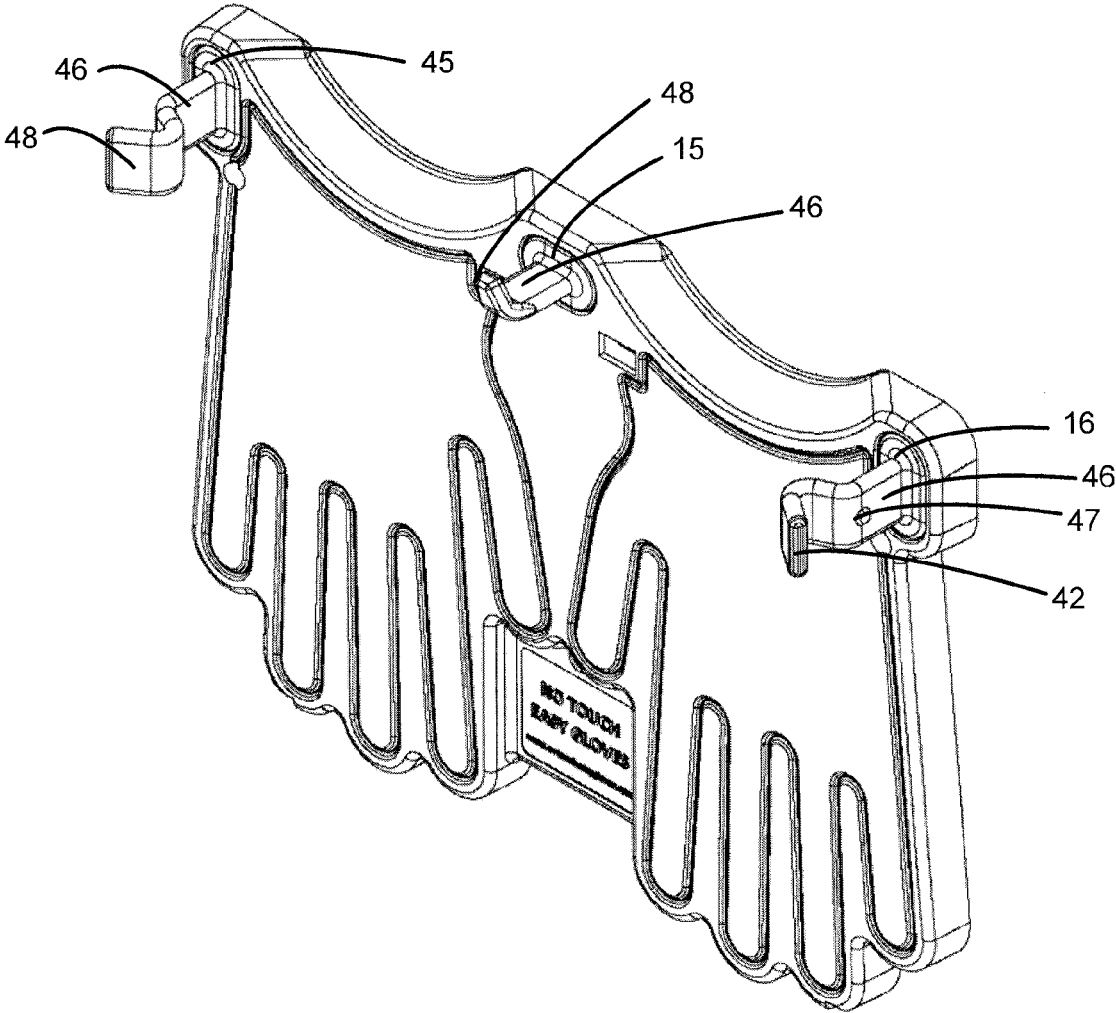

FIG. 7C

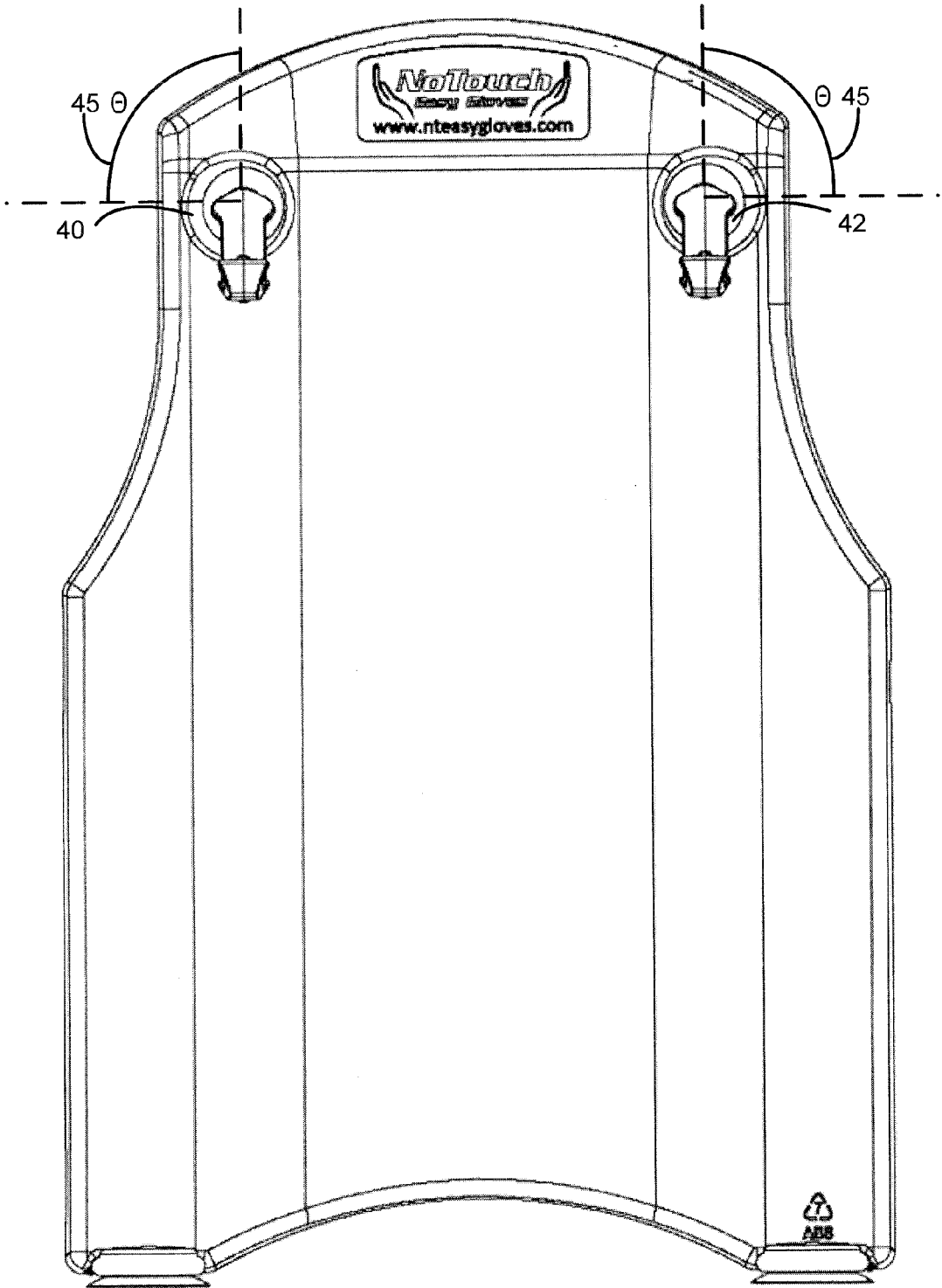

FIG. 7D

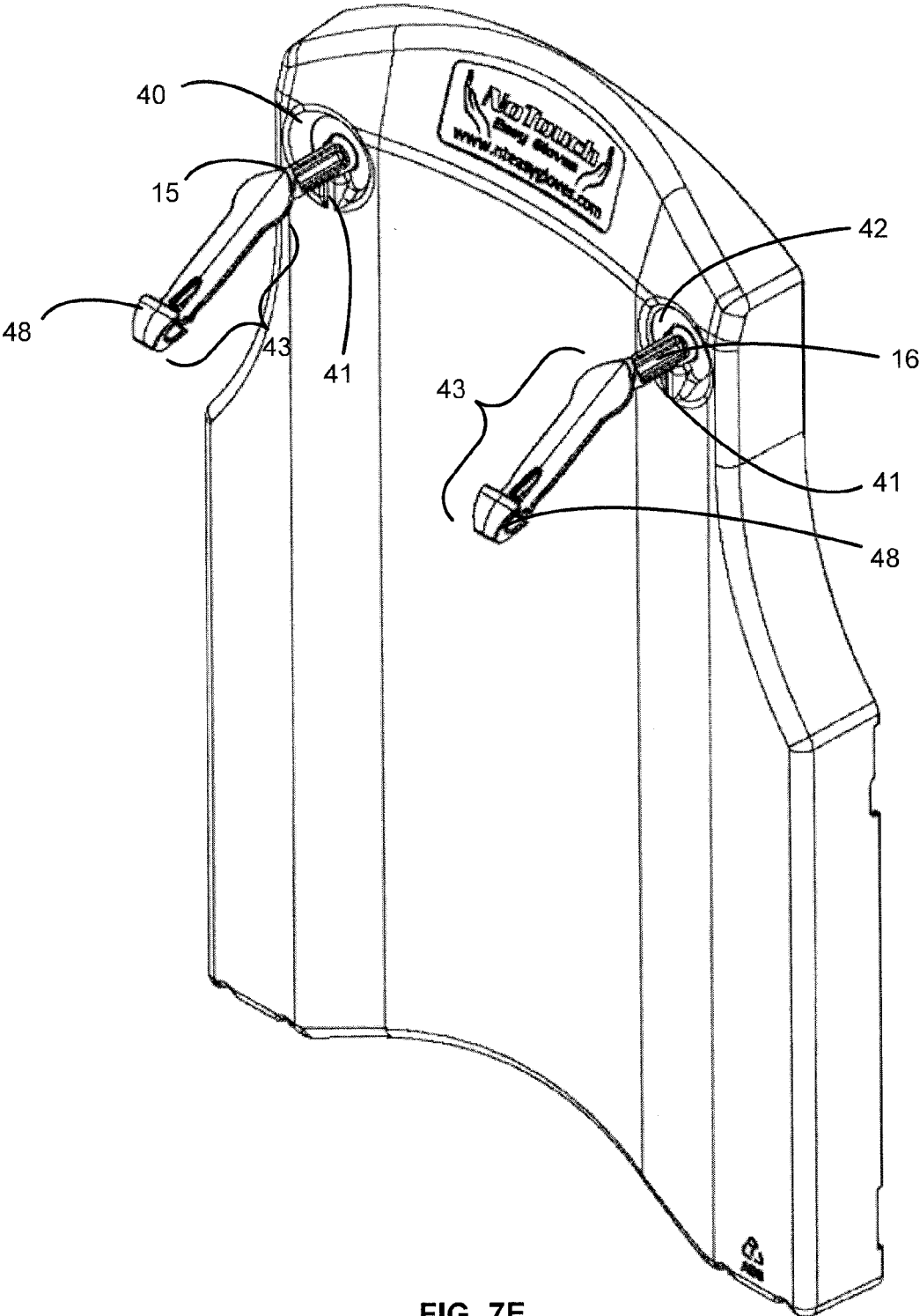

FIG. 7E

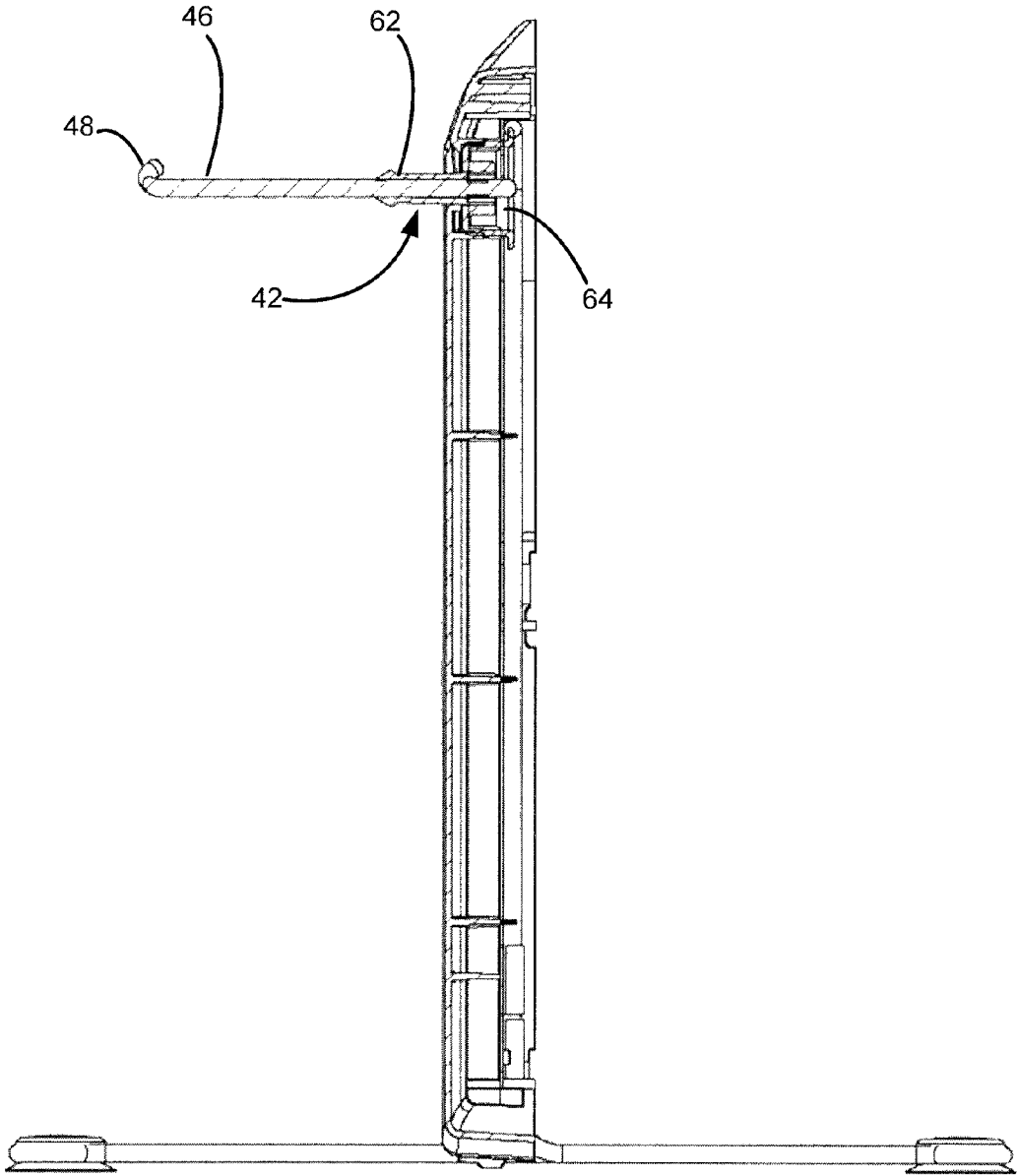

FIG. 8A

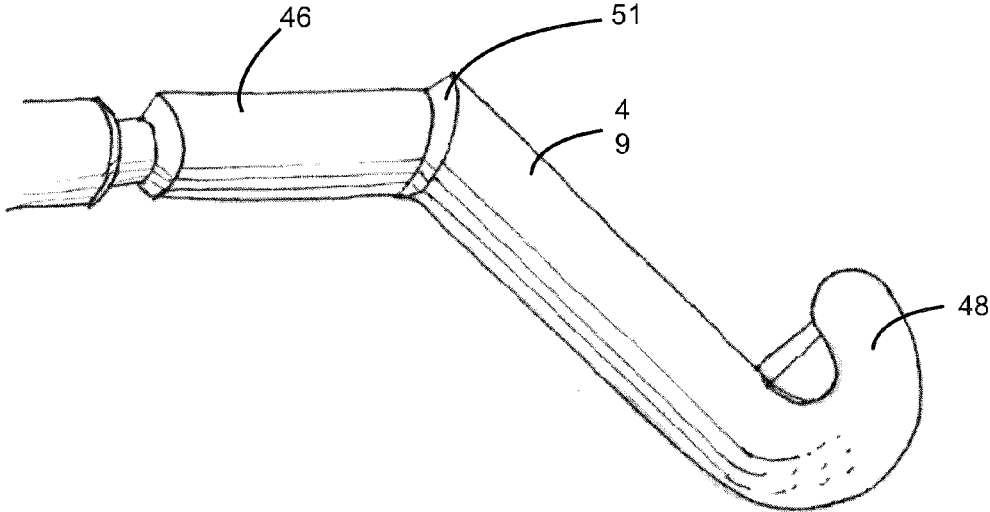

FIG. 8B

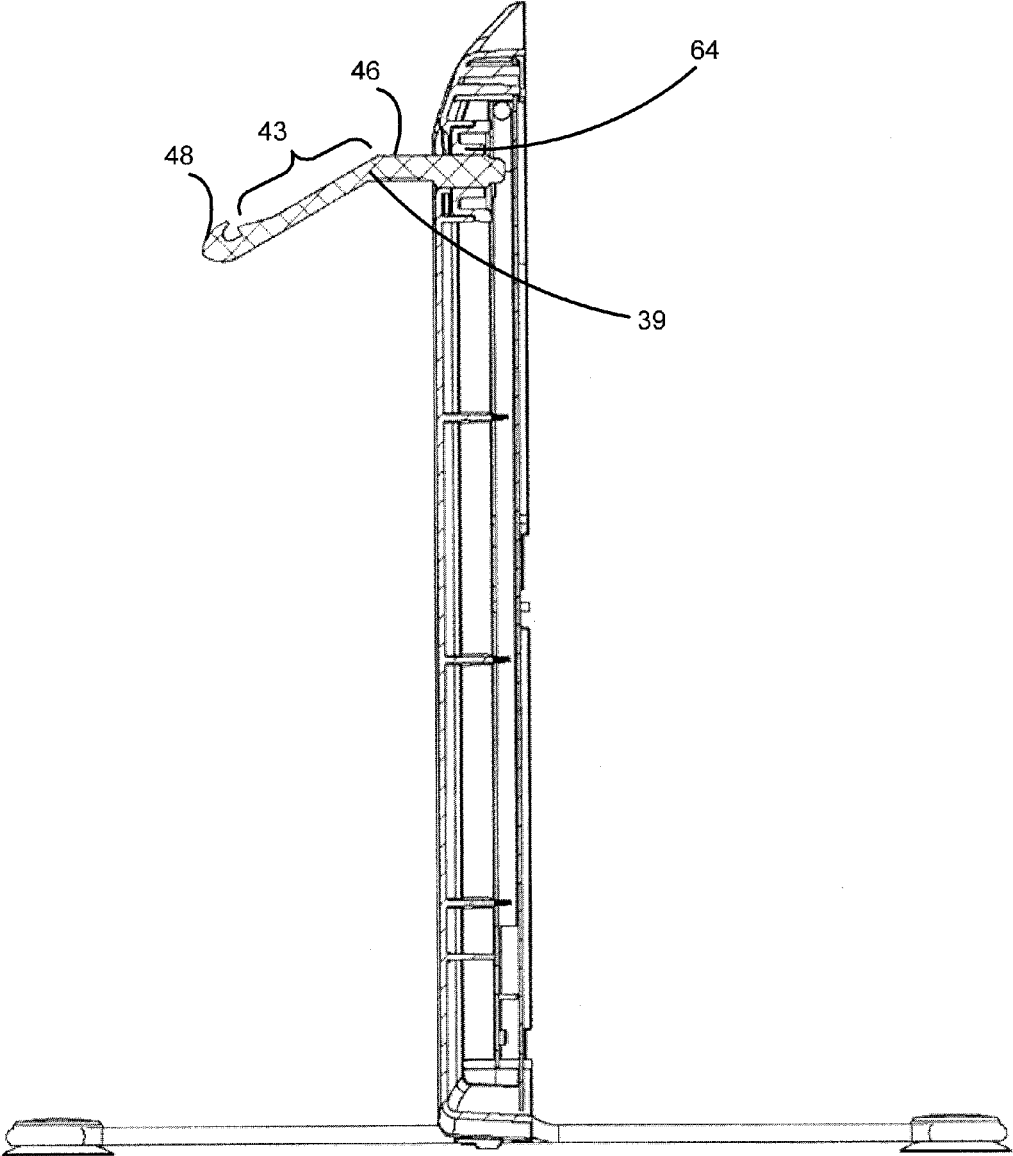

FIG. 8C

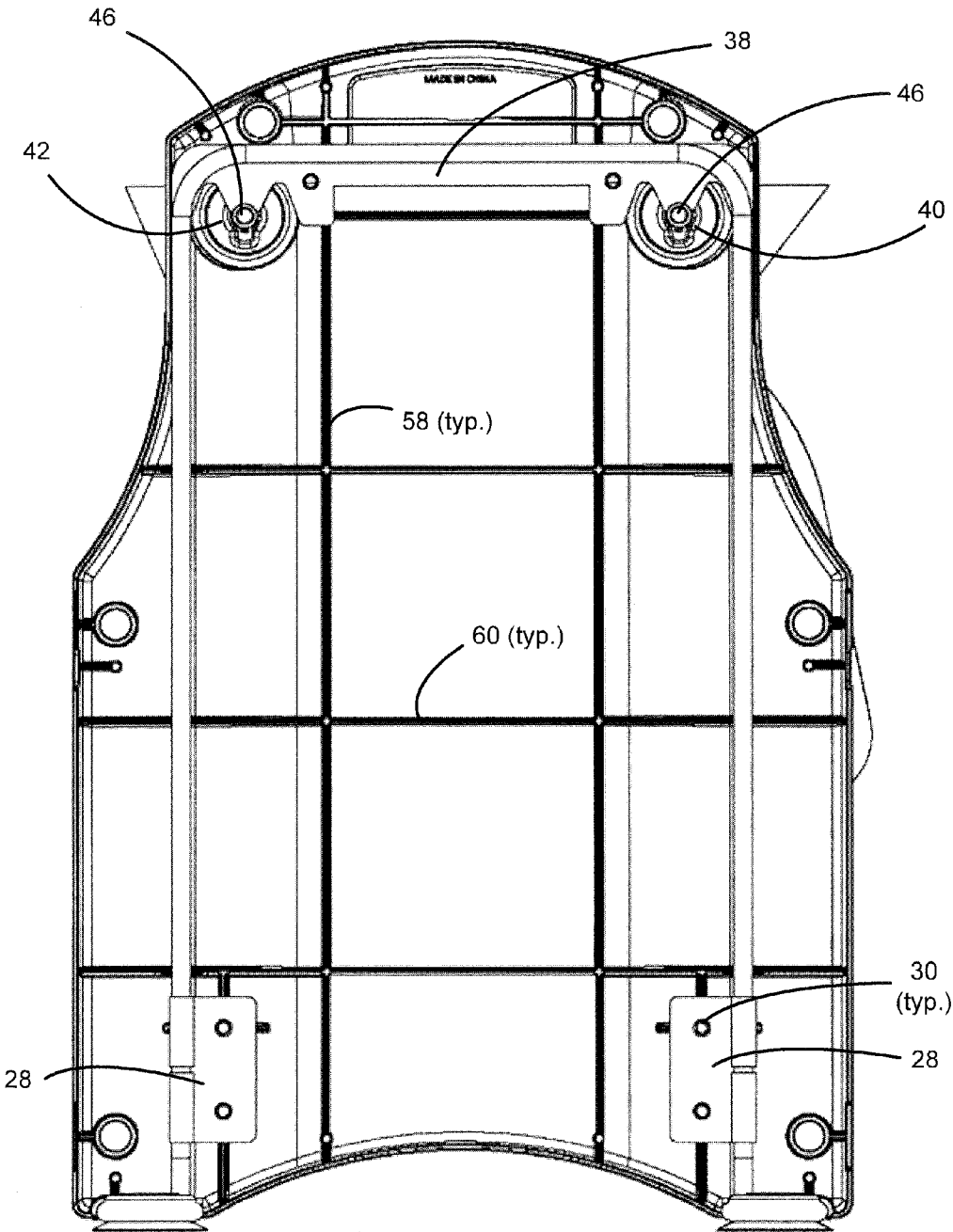

FIG. 9

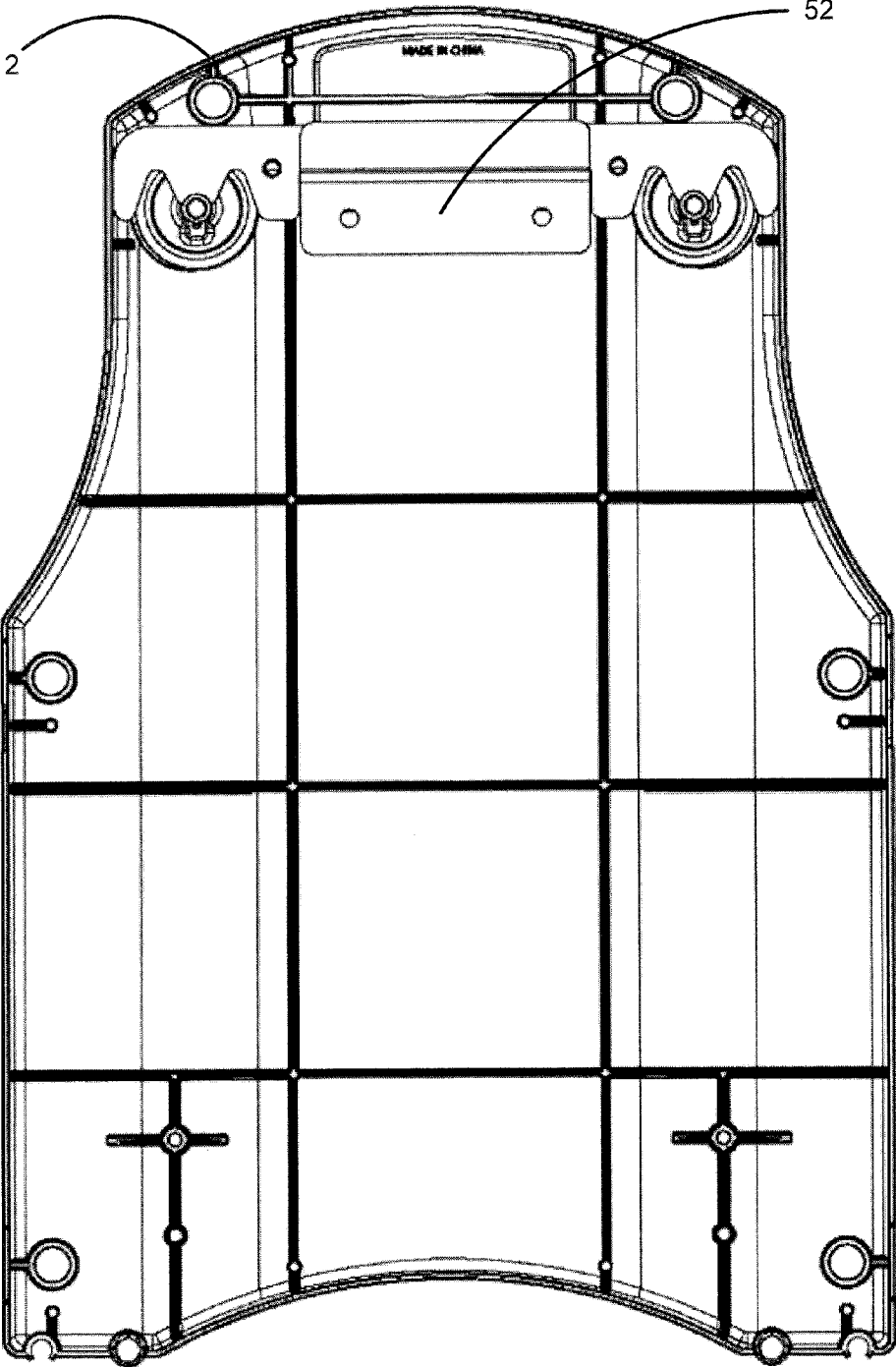

FIG. 10

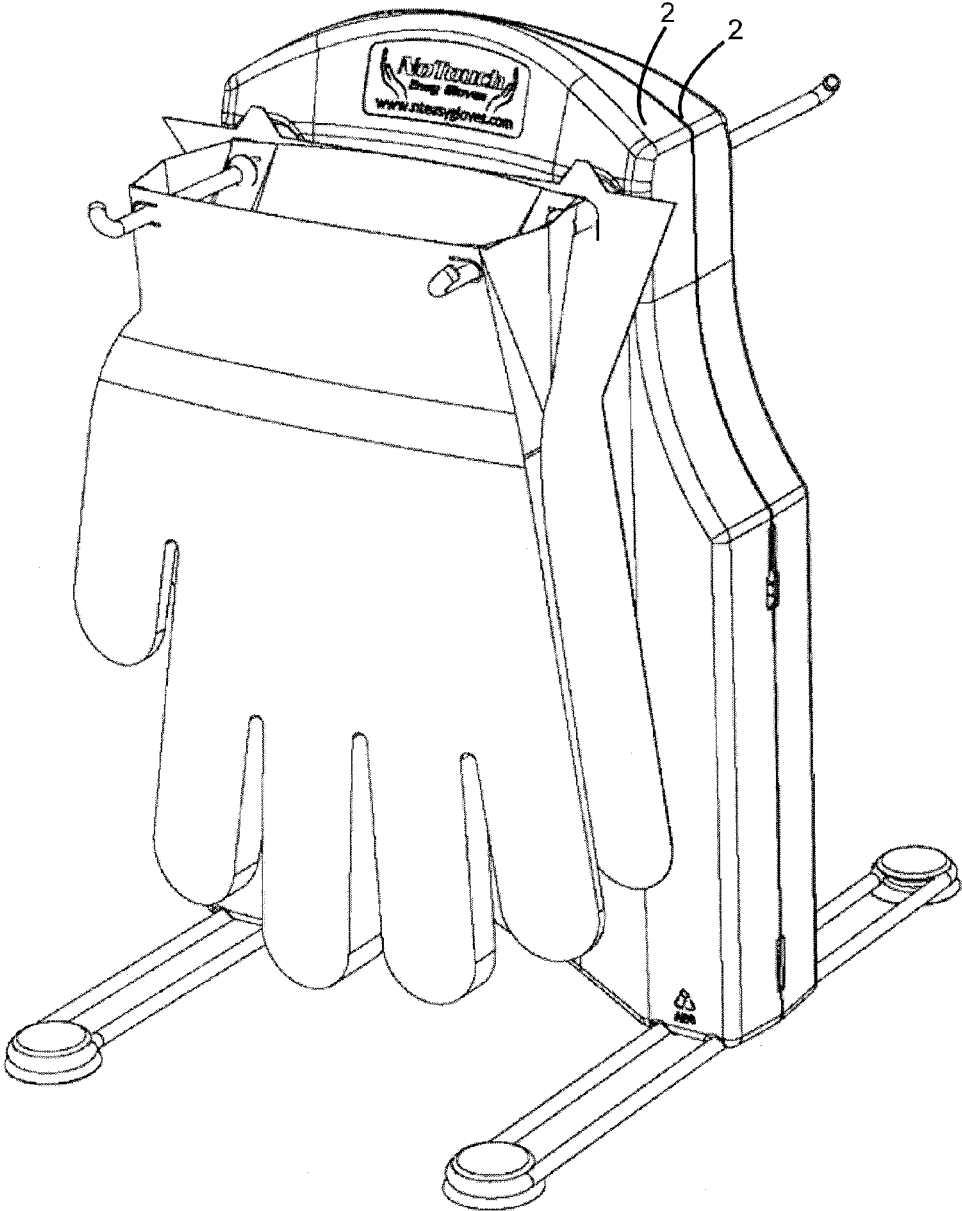

FIG. 11A

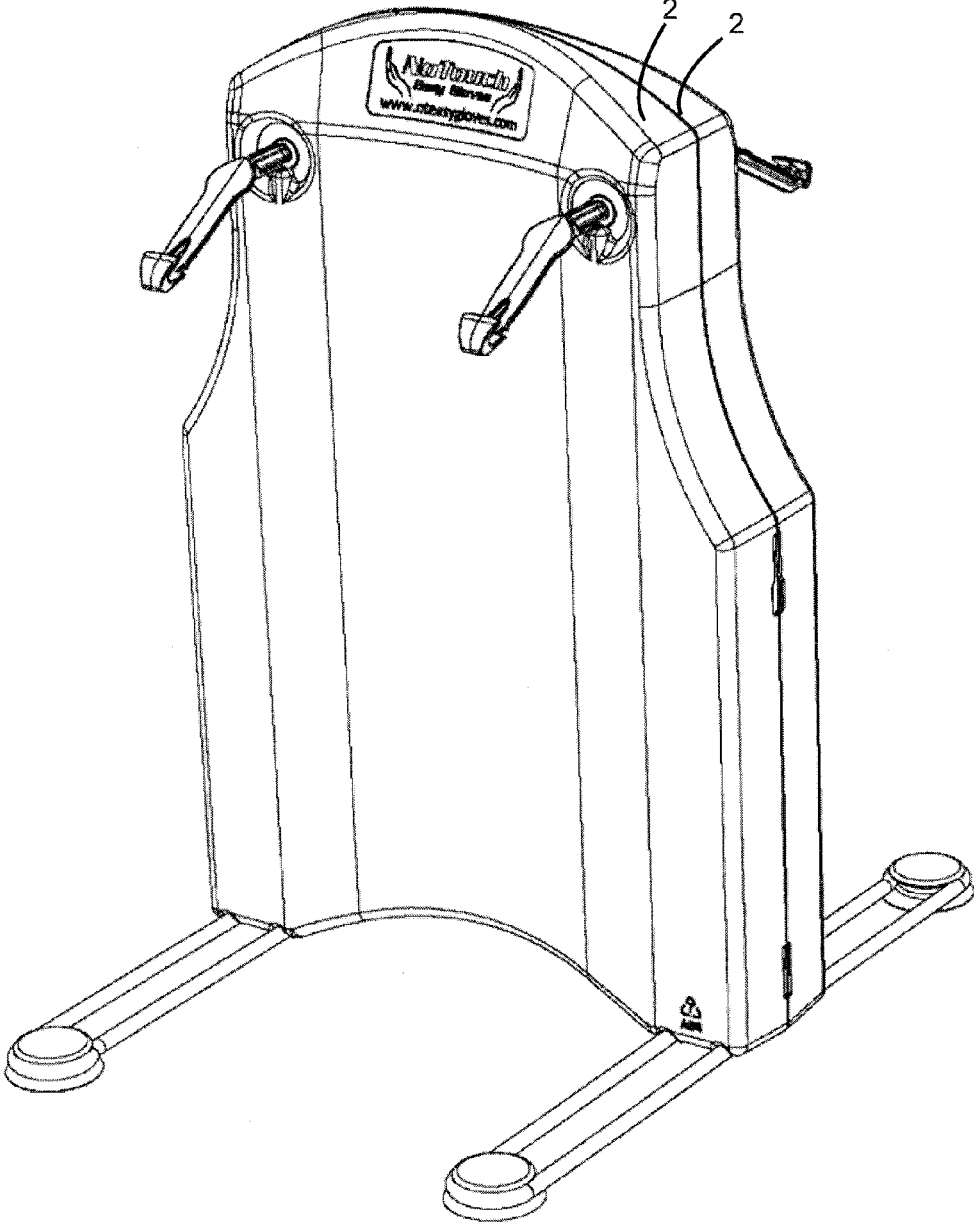

FIG. 11B

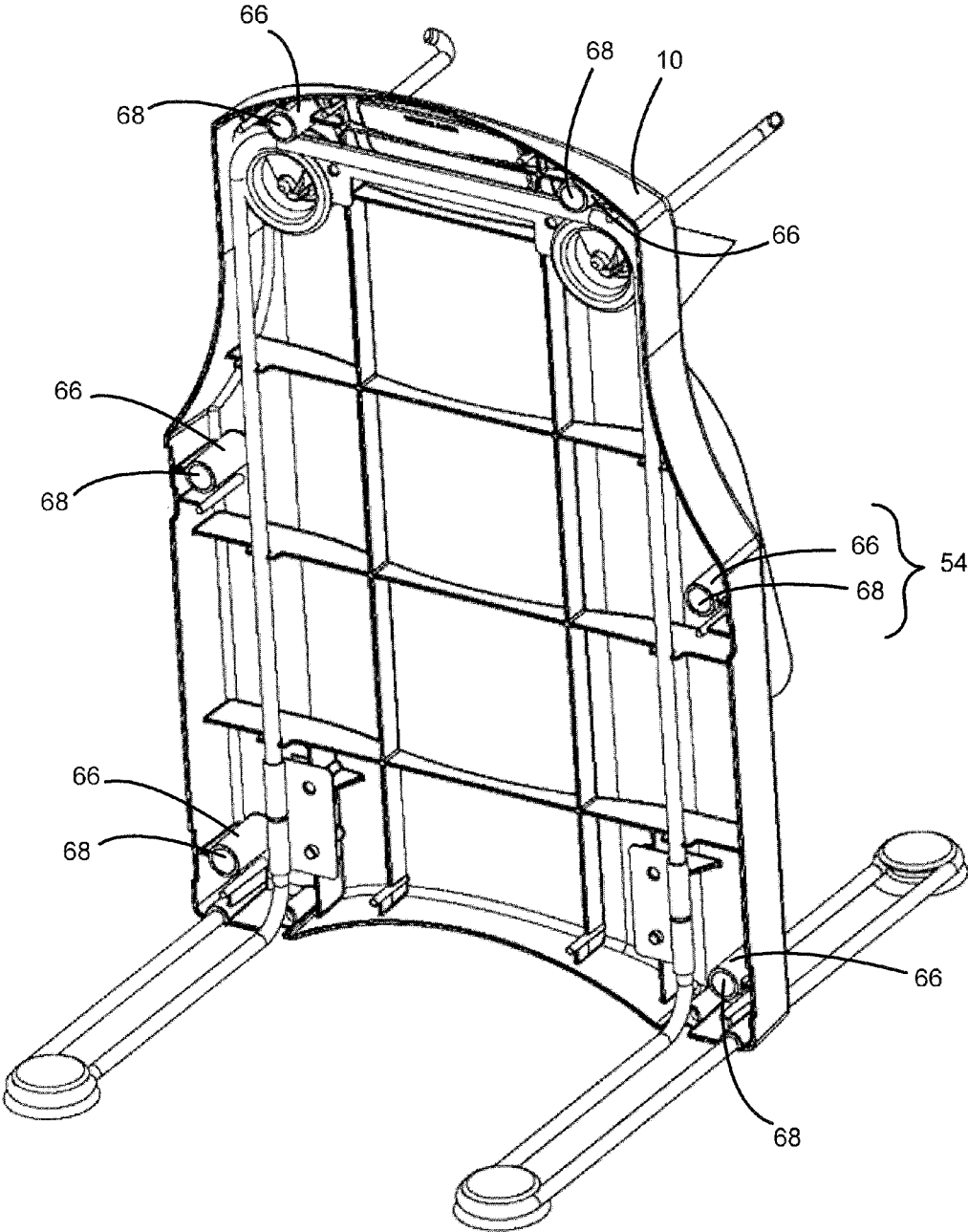

FIG. 12

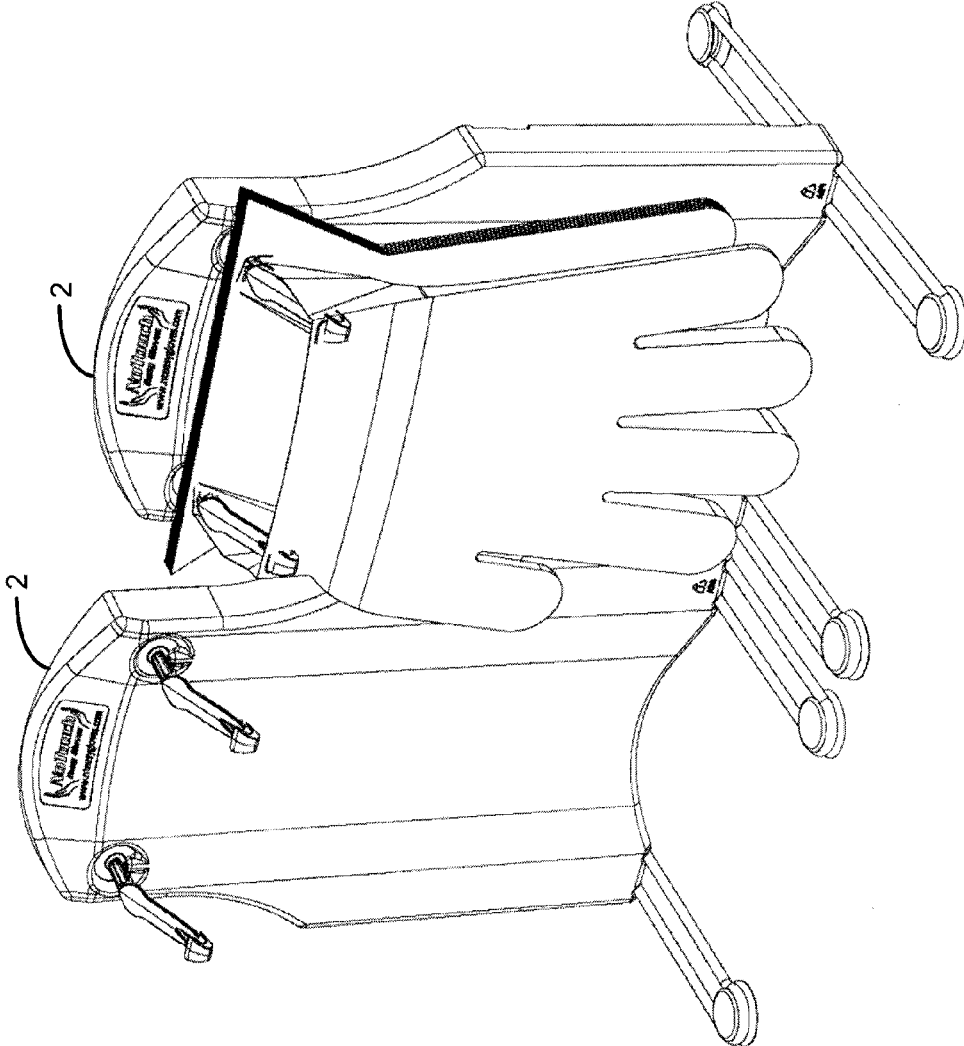

FIG. 13B

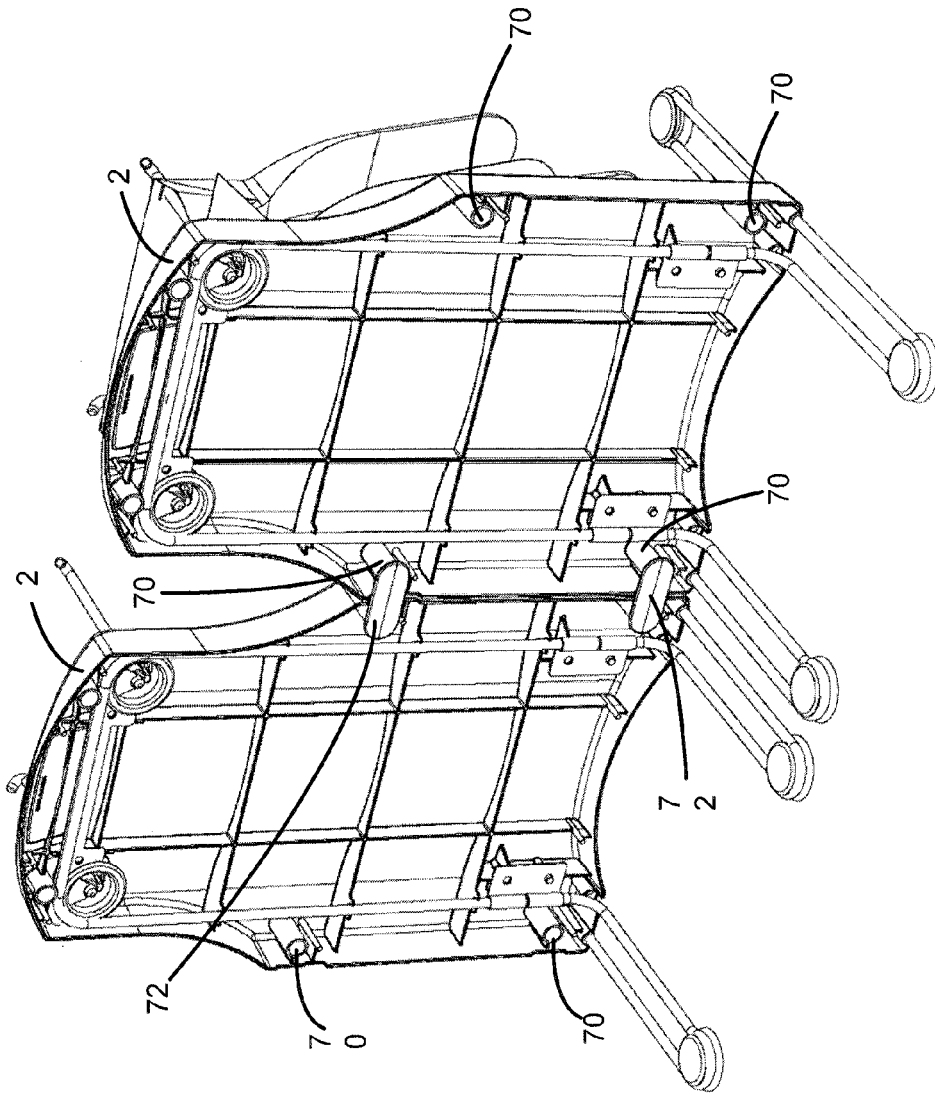

FIG. 14A

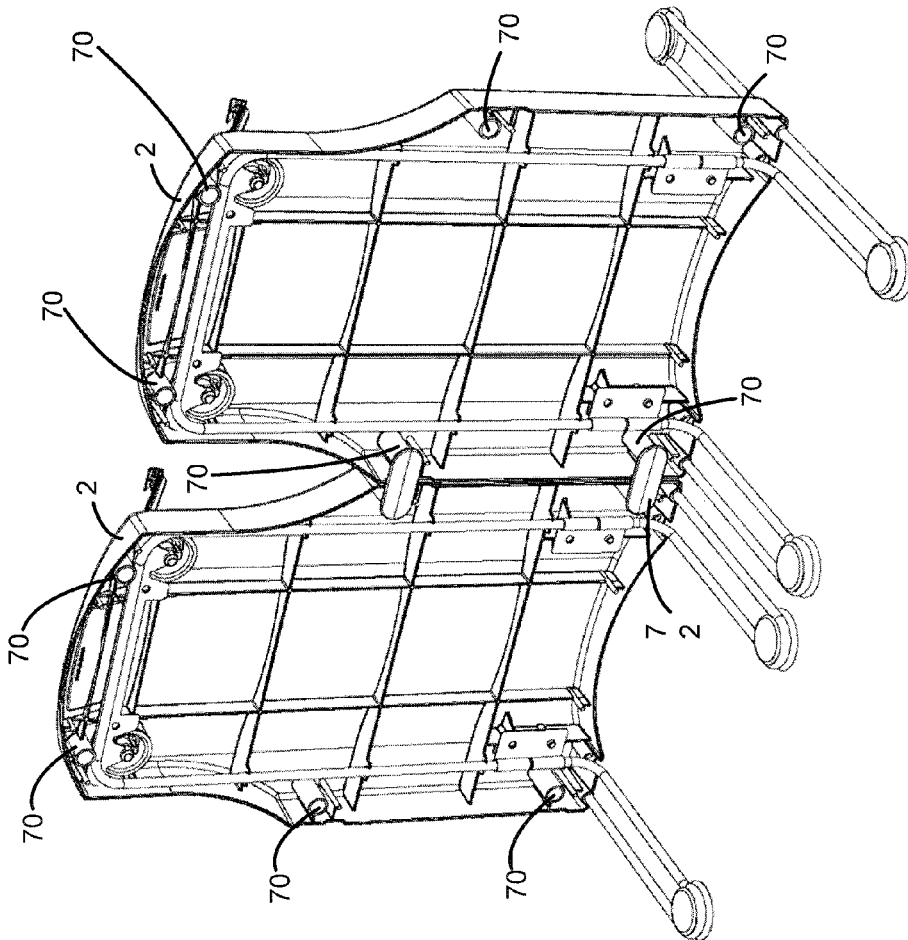

FIG. 14B

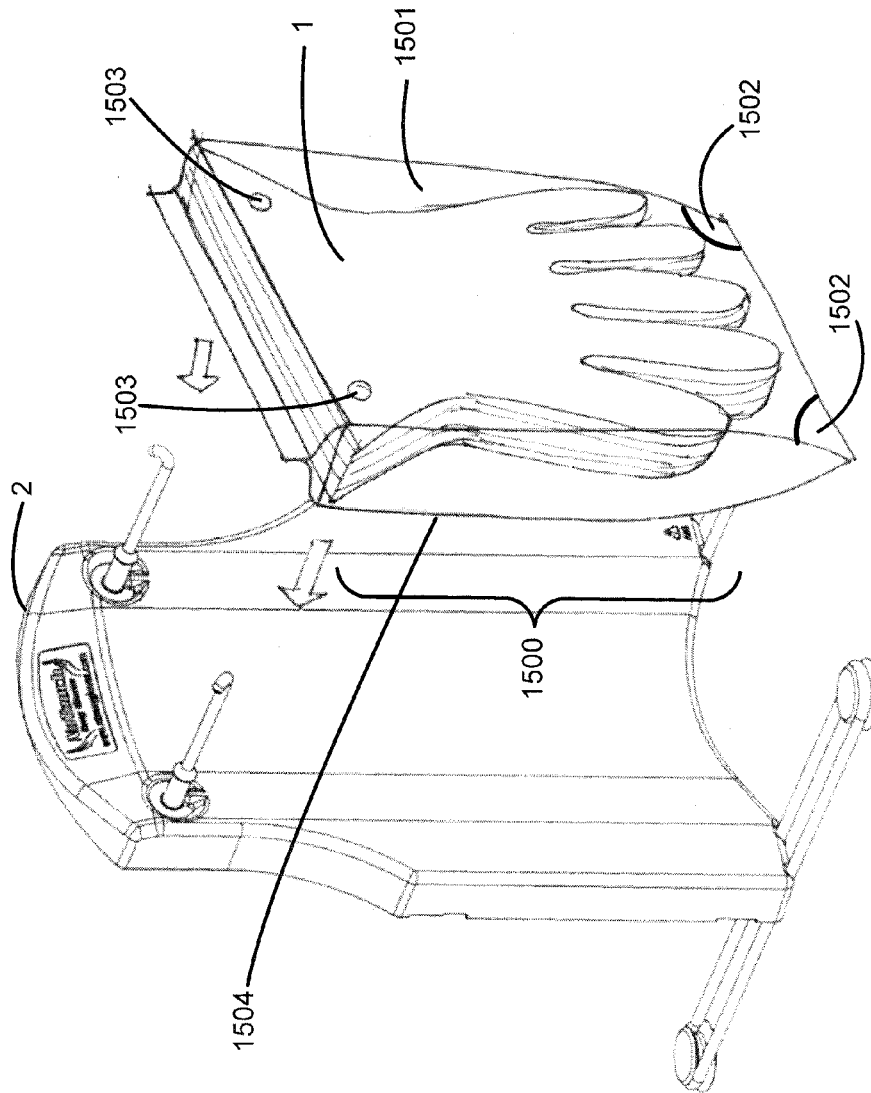

FIG. 15A

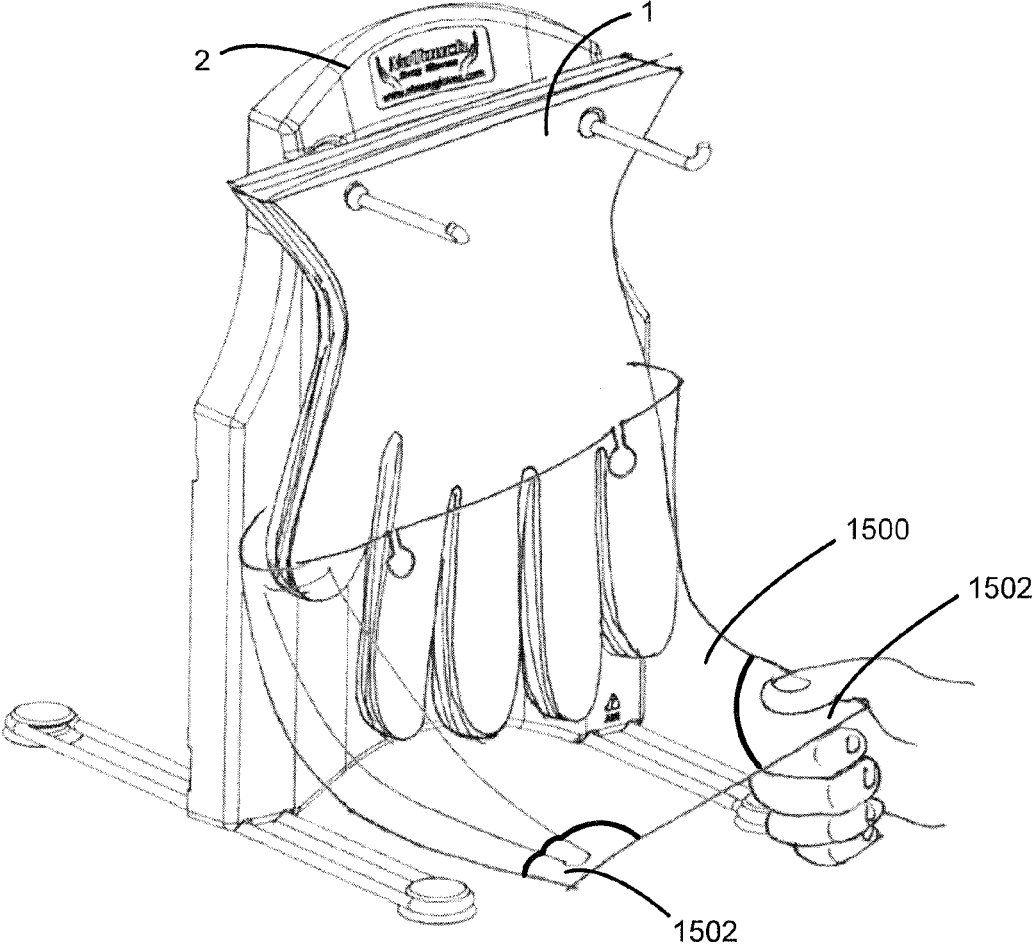

FIG. 15B

1

**METHOD AND APPARATUS FOR
DISPOSABLE GLOVE DISPENSING**

CLAIM OF PRIORITY

This application is a continuation of U.S. Non-Provisional patent application Ser. No. 14/332,119, filed Jul. 15, 2014, entitled "METHOD AND APPARATUS FOR DISPOSABLE GLOVE DISPENSING," which claims priority to U.S. Non-Provisional patent application Ser. No. 14/331,061, filed Jul. 14, 2014, now U.S. Pat. No. 8,960,493, entitled "METHOD AND APPARATUS FOR DISPOSABLE GLOVE DISPENSING," which claims the benefit of U.S. Provisional Patent Application Ser. No. 61/870,223, filed Aug. 26, 2013, entitled "METHOD AND APPARATUS FOR DISPOSABLE GLOVE DISPENSING," which are each hereby incorporated by reference in the entirety for all purposes.

BACKGROUND

Medical professionals, restaurant employees, and any other individual that handles food, chemicals, samples, or in any way is attempting to prevent the spread of germs cannot be sure they are operating effectively if the outside of a glove is touched prior to the user putting the gloves on their hands. Thus, it is desirable to have a delivery method and apparatus for allowing the user to insert their hands directly into an open glove without contaminating the glove outer surface.

SUMMARY

A disposable glove dispensing system may allow for a user to efficiently put on a disposable glove without touching the outside of the glove. In various embodiments, a disposable glove may comprise an opening for hand entry having a first opening edge and a second opening edge, a first interconnection point located near the first opening edge, wherein the first interconnection point attaches the disposable glove to a first adjacent disposable glove, and a second interconnection point located near the second opening edge. The second interconnection point may attach the disposable glove to a second adjacent disposable glove, wherein the disposable glove is positioned between the first adjacent disposable glove and the second adjacent disposable glove.

Furthermore, in various embodiments, a disposable glove dispensing system may comprise a pack of disposable gloves, where an individual disposable glove of the pack of disposable gloves is interconnected to adjacent disposable gloves, and a glove dispenser comprising a first glove hanger and a second glove hanger, where the pack of disposable gloves hang from the first glove hanger and the second glove hanger. Moreover, the glove dispenser may further comprise a main body connected to the first glove hanger and the second glove hanger, and further comprise a support member connected to the main body.

Moreover, in various embodiments, a method of dispensing a disposable glove is provided. A method of dispensing a disposable glove may include opening a disposable glove having a first opening edge and a second opening edge. The disposable glove may hang from a glove dispenser having a first glove hanger and a second glove hanger. The disposable glove also may be attached to an adjacent disposable glove by an interconnection point located near one of the first opening edge or the second opening edge. The method may further include inserting a hand into the disposable glove,

2

tearing the interconnection point, and removing the disposable glove from the glove dispenser.

BRIEF DESCRIPTION OF THE DRAWINGS

5

The subject matter of the present disclosure is particularly pointed out and distinctly claimed in the concluding portion of the specification. A more complete understanding of the present disclosure, however, may best be obtained by referring to the detailed description and claims when considered in connection with the drawing figures, wherein like numerals denote like elements.

10

FIG. 1 illustrates a perspective view of a disposable glove pack and a glove dispenser, in accordance with various embodiments;

15

FIG. 2 illustrates a close-up perspective view of a disposable glove pack and interconnection point(s), in accordance with various embodiments;

20

FIGS. 3A-B illustrate front views of exemplary disposable gloves, in accordance with various embodiments;

FIG. 4 illustrates a block figure of an exemplary view of a glove dispenser, in accordance with various embodiments;

25

FIG. 5A illustrates a perspective view of a disposable glove pack and a glove dispenser, in accordance with various embodiments;

30

FIG. 5B illustrates a perspective view of a disposable glove pack and a side-by-side glove dispenser, in accordance with various embodiments;

FIG. 5C illustrates a perspective view of a glove dispenser with glove hangers having a widened retention portion, in accordance with various embodiments;

FIGS. 6A-B illustrate top-down views of dispensing stands, in accordance with various embodiments;

35

FIG. 7A illustrates a front view of a glove dispenser, in accordance with various embodiments;

FIG. 7B illustrates a close-up perspective view of a glove dispenser and glove hangers, in accordance with various embodiments;

40

FIG. 7C illustrates a perspective view of a side-by-side glove dispenser and glove hangers, in accordance with various embodiments;

FIG. 7D illustrates a front view of a glove dispenser with glove hangers having a widened retention portion, in accordance with various embodiments;

45

FIG. 7E illustrates a close-up perspective view of a glove dispenser and glove hangers having a widened retention portion, in accordance with various embodiments;

FIG. 8A illustrates a side view of a glove dispenser and glove hangers, in accordance with various embodiments;

50

FIG. 8B illustrates a side view of a glove hanger, in accordance with various embodiments;

FIG. 8C illustrates a side view of a glove hanger having a widened retention portion, in accordance with various embodiments;

55

FIG. 9 illustrates a back view of a glove dispenser, in accordance with various embodiments;

FIG. 10 illustrates a back view of a hanging glove dispenser, in accordance with various embodiments;

60

FIG. 11A illustrates a perspective view of a back-to-back glove dispenser stand, in accordance with various embodiments;

FIG. 11B illustrates a perspective view of a back-to-back glove dispenser stand with glove hangers having a widened retention portion, in accordance with various embodiments;

65

FIG. 12 illustrates a perspective view of the back of a glove dispenser, in accordance with various embodiments;

3

FIG. 13A illustrates a perspective view of the front of a side-by-side glove dispenser, in accordance with various embodiments

FIG. 13B illustrates a perspective view of the front of a side-by-side glove dispenser with glove hangers having a widened retention portion, in accordance with various embodiments;

FIG. 14A illustrates a perspective view of the back of a side-by-side glove dispenser, in accordance with various embodiments.

FIG. 14B illustrates a perspective view of the back of a side-by-side glove dispenser with glove hangers having a widened retention portion, in accordance with various embodiments; and

FIGS. 15A-B illustrate perspective views of a disposable glove pack having a cover and a glove dispenser, in accordance with various embodiments.

DETAILED DESCRIPTION

The detailed description herein makes use of various exemplary embodiments to assist in disclosing the present invention. While these exemplary embodiments are described in sufficient detail to enable those skilled in the art to practice the invention, it should be understood that other embodiments may be realized and that modifications of structures, arrangements, applications, proportions, elements, materials, or components used in the practice of the instant invention, in addition to those not specifically recited, can be varied or otherwise particularly adapted to specific environments, manufacturing specifications, design parameters or other operating requirements without departing from the scope of the present invention and are intended to be included in this disclosure. Thus, the detailed description herein is presented for purposes of illustration only and not of limitation.

For the sake of brevity, conventional techniques for manufacturing and construction may not be described in detail herein. Furthermore, the connecting lines shown in various figures contained herein are intended to represent exemplary functional relationships and/or physical couplings between various elements. It should be noted that many alternative or additional functional relationships or physical connections may be present in a practical method of construction.

Disclosed herein are one or more apparatuses and methods for inserting hands into disposable gloves without touching the outside of the gloves. This is beneficial for use in different industries, such as restaurant or other food-related industries. Virtually every fast food chain in the world requires all employees coming into contact with ingredients or food to use multiple pairs of plastic gloves each and every day. Touching the outside of the gloves can contaminate the surface and reduce the effectiveness of using the gloves. The disclosure can also have applications in the medical industry, which includes medical hospitals/clinics, long-term care facilities, outpatient surgical centers, doctor offices, dental offices, laboratories, and veterinary clinics. Furthermore, the disclosed methods and apparatuses could also be used in the home.

The disposable gloves as discussed herein can include gloves made of latex, nitrile, polyethylene, polyvinyl chloride, vinyl, and other suitable materials. The disposable gloves may also have different thicknesses of the materials for reducing contamination. For example, gloves for medical applications can be thicker than gloves for food handling

4

applications. The disposable gloves can come in multiple packs of different sizes, such as small, medium, or large, and the like.

In accordance with various embodiments and with reference to FIG. 1, a disposable glove dispensing system may comprise a pack of disposable gloves 1 attached to a glove dispenser 2. The disposable glove pack can comprise several gloves. Each glove can be flat and connected between other adjacent disposable gloves 1 at one or more connection points. With reference to FIGS. 1 and 2, each glove may have a first opening edge 9 on a forward side of the disposable glove (see also, FIGS. 2, 5A, 11A, 13A, 14A, 15B) and a second opening edge 10 on an aft side of the disposable glove (see also, FIGS. 2, 5A, 11A, 13A, 14A, 15B). When the glove is opened, the first opening edge 9 and the second opening edge 10 are spread from one another so that a hand may be inserted between the first opening edge 9 and the second opening edge 10 and into the body of the glove 1.

In accordance with various embodiments, FIG. 5B illustrates two adjacent disposable gloves 1 connected by an inner support sheet 6. The inner support sheet 6 may provide strength and stability to the gloves when hanging from glove dispenser 2, yet also facilitate the easy removal of the gloves. For example, interconnection point(s) 4 may be spaced around the perimeter of inner support sheet 6, providing regions wherein the force of a user's hand when pulling the gloves away from the glove dispenser 2 may be concentrated, facilitating local tearing at interconnection point(s) 4 and easy removal of the gloves from the glove dispenser 2.

In accordance with various embodiments, FIG. 2 illustrates a close-up view of exemplary interconnection point(s) between multiple gloves. As shown in FIG. 2, in various embodiments, a first disposable glove 1A may have an interconnection point 4 to an adjacent second disposable glove 1B, and the second disposable glove 1B may have an interconnection point 4 to an adjacent third disposable glove 1C. As the first disposable glove 1A is drawn away from the glove pack, the interconnection point(s) 4 pull the adjacent second glove 1B open, staging the adjacent second glove 1B ready to receive the next hand. In this manner, a disposable glove remains ready and available for a person to put on the disposable gloves without having to touch the outside of the gloves.

The interconnection point 4 may be located near a hanging point on a glove hanger, for example, as illustrated in FIGS. 2, 3A-B, and 5B. In various embodiments, the gloves may be separated, and thereby the interconnection point(s) 4 separated, by pulling the top edge of the glove along the axis of each glove hanger. As shown in FIGS. 2 and 3A-B, in various embodiments, the interconnection point 4 may be connected tabs from a punch-out of a hole for the glove hanger. In various embodiments, a glove hanger may be inserted into the punch-out hole, and the resulting tabs from the punch-out are retained and formed into the interconnection point(s). Alternatively, in various embodiments, an interconnection point 4 may occur anywhere along the top edge of the gloves. Furthermore, in various embodiments, the interconnection point(s) 4 can be perforated and have thinner plastic areas, with small connection points that may be easily broken. Additionally, the interconnection point(s) 4 may be connected via heat sealing, an adhesive, an interlock tab, or a combination thereof. When the interconnection point(s) 4 are pulled, the interconnection point(s) 4 may separate by introducing sheer force to separate the adhesive or weld dots on each interconnection point 4.

5

With momentary reference to FIG. 3B, in various embodiments, the gloves may individually further comprise one or more tear points **8** near the top edge. A tear point **8** may comprise an aperture through the glove **1**, or thinner regions, or perforations or other like structures for removably coupling gloves to a sanitary sealed film glove package **1500** (see FIG. 15A-B). This aperture may permit a sanitary sealed film glove package **1500** (see FIGS. 15A-B) to interface with the gloves. For example, a portion of the glove package that is disposed in contact with the outermost glove may be attached to a portion of the glove package that is disposed in contact with the innermost glove. For example, the glove package may comprise a metallic material aligned with the tear point **8**. The metallic material may be warmed by RF welding so that the portion of the glove package disposed in contact with the outermost glove melts to the portion of the glove package disposed in contact with the inner most glove, through the tear point **8**. Other embodiments may comprise tear point(s) **8** located anywhere proximate the top edge, e.g., a glove **1** may individually comprise two tear points **8** disposed along the top edge, although a glove **1** may comprise any number of tear points **8** disposed at any position to facilitate removably coupling gloves to a sanitary sealed film glove package **1500** (see FIGS. 15A-B).

With continued reference to FIGS. 2 and 3A, the disposable gloves **1A**, **1B**, **1C** may individually further comprise a pull tab **5** on the top edge. The pull tab **5** may be used to facilitate further opening of a disposable glove by pulling of the pull tab **5**. A user may be able to pull the pull tab **5** to open the glove with minimal contact between the glove and the user. With reference to FIG. 3C, further embodiments may omit the pull tab **5**.

In accordance with various embodiments and with renewed reference to FIGS. 1 and 3A-B, the disposable glove **1** may further comprise one or more gussets **3** located on one or more sides of the first opening edge **9** and the second opening edge **10** making up the glove opening. The extra material of the gusset **3** may allow easier separation of the opening by facilitating expansion of the glove opening when the glove is hanging. Specifically, the gussets **3** can provide additional slack to the glove opening such that the glove may be opened with little or no resistance and allowing an opening that is sufficiently wide for hand insertion. The gussets **3** may provide additional linear edge to the opening of the glove thereby allowing the distance from the first opening edge **9** and the second opening edge **10** to increase as the glove is opened. In various embodiments, the gussets **3** are triangular in shape though other shapes, such as rhomboid or parabolic, may be used. Additionally, the gusset **3** may be in-board or out-board of the hanging points of the glove hanger. An out-board gusset results in the extra gusset material being outside of the glove opening, creating a flared glove opening. Similarly, the in-board gusset results in the extra gusset material being folded inside the glove opening.

Though the gloves may come in different sizes (small, medium, large, etc.) as previously mentioned and with reference to FIG. 3B, a disposable glove **1** may also be designed to better fit a user's hand. In various embodiments, the disposable glove **1** may comprise tack points **7** around the inside perimeter. For example, the glove may have tack points near the wrist area and/or around the perimeter of the fingers. The tack points **7** may be formed using light tack adhesion to create a series of interconnected points. As the user inserts a hand, the tack points **7** break to accommodate the size of the user's hand. Any unbroken tack points **7** provide a more snug fit around the hand.

6

In accordance with various embodiments, and with reference to FIGS. 4 and 5A-C, a glove dispenser **2** may comprise a main body **14**, a support member **13**, and a glove retention member **12**. In various embodiments, the glove dispenser **2** is a unitary body, or an assembly of different pieces, or may comprise any arrangement of elements whereby gloves may be dispensed.

The glove dispenser **2** may comprise a main body **14** standing upright and an attached support member **13** to stabilize the main body **14**. Alternatively, the glove dispenser **2** may comprise a self-supporting unitary body joined with a glove retention member **12**. As discussed further herein, the glove retention member **12** may be connected to the main body **14** and may support gloves to be dispensed. In this manner, the main body **14** may be sufficiently tall that it may hold the gloves vertically. In various embodiments, the main body **14** may comprise a molded plastic body, may comprise metal or ceramic, may be a bent metal channel, may comprise a machined part, or may be any structure adapted to support the glove retention member **12**.

Furthermore, in various embodiments and with reference to FIGS. 5A and 5C, the glove retention member **12** may comprise a pair of glove hangers, for example, a first glove hanger **15** and a second glove hanger **16**. For example, a pair of glove hangers may extend normal to a face of the main body **14**. In this manner, gloves may be connected to the glove hangers and supported thereby. In one embodiment, the first glove hanger **15** is parallel to the second glove hanger **16**. In another embodiment, the first glove hanger **15** and the second glove hanger **16** may be angled towards each other, with the hangers narrowing towards each other away from the main body **14**. In this manner, the gloves may be taut near the main body **14** and have more slack near the hanger ends to be easier to insert a hand. In various embodiments, the glove retention member **12** may comprise one glove hanger, three glove hangers, or any number of glove hangers configured to support gloves. Moreover, the glove retention member **12** may comprise tabs, or clips, or hooks, or any other apparatus or combination of apparatuses designed to support at least one glove. In various embodiments, the glove dispenser **2** may comprise a single glove retention member **12** comprising a pair of glove hangers. However, in various other embodiments, the glove dispenser **2** may comprise two to four glove retention members **12**, or any other suitable number of glove retention members **12**, so that multiple gloves may be separately supported by the glove dispenser **2**.

In various embodiments and with reference to FIG. 5B, the glove dispenser **2** may comprise two glove retention members **12**, which may comprise various combinations of glove hangers. For example, the two glove retention members **12** may share a second glove hanger **16**. Thus, one glove retention member **12** may comprise a left side first glove hanger **15**, a centrally positioned second glove hanger **16**. The other glove retention member **12** may comprise a right side first glove hanger **15** and the centrally disposed second glove hanger **16** which is shared by the two glove retention members **12**. In other embodiments, the glove retention member **12** comprises two complete pairs of glove hangers, so that a first glove hanger **15** and a second glove hanger **16** support each disposable glove **1**. The glove hangers may extend normal to a face of the main body **14**. In this manner, disposable gloves **1** may be connected to the glove hangers and supported thereby. In one embodiment, the glove hangers are parallel. In another embodiment, the first glove hanger **15** may be angled outwardly from the main body **14** and the second glove hanger **16** may be angled upwardly

from the main body **14**. In this manner, the gloves may be prevented from sliding off of the glove retention hangers. In various embodiments, the glove retention member **12** may comprise one glove hanger, three glove hangers, or any number of glove hangers configured to support gloves. Moreover, the glove retention member **12** may comprise tabs, or clips, or hooks, or any other apparatus or combination of apparatuses designed to support at least one glove. In various embodiments, the glove dispenser **2** may comprise a single glove retention member **12** comprising a pair of glove hangers. However, in various other embodiments, the glove dispenser **2** may comprise two to four glove retention members **12**, or any other suitable number of glove retention members **12**, so that multiple gloves may be separately supported by the glove dispenser **2**. In still other embodiments, as illustrated in FIG. 5B, the glove dispenser **2** may comprise two glove retention members **12** sharing a centrally positioned second glove hanger **16**, so that multiple gloves may be supported by the glove dispenser **2**.

In various embodiments, and with reference to FIGS. 5A and 5C, the support member **13** may comprise four supporting legs disposed perpendicular to a Y-Z plane intersecting the main body **14**, or in any direction whereby the glove dispenser **2** may be supported. For example, if the main body **14** may be said to be standing upright (e.g., vertically), the support member **13** may be said to be lying beneath the main body **14** (e.g., horizontally). If the Y-Z plane may be said to intersect the main body **14**, the legs may be said to lie in the X-Z plane, and the X-Y plane may be said to bisect the main body **14** as referenced in FIG. 5. In various embodiments, the support member **13** prevents the main body **14** from toppling. In various embodiments, the support member **13** may comprise any number of legs, or may not comprise legs but may comprise a singular leg, for example, a large planar leg, or may comprise three legs, for example a tripod. In various embodiments, and with reference to FIG. 5B, the support member **13** may comprise two supporting legs disposed perpendicular to a Y-Z plane intersecting the main body **14**, or in any direction whereby the glove dispenser **2** may be supported. The support member **13** may be removable, for instance, to permit compact shipping and storage.

The main body **14** may comprise a unitary plastic body, for example, a main body **14** may support the glove retention member **12**. A main body **14** may comprise a rectangular body, or a triangular body, or a wire frame body, or may comprise any arrangement of elements whereby the glove retention member **12** may be disposed at a position whereby gloves may be supported without unwanted interference from surrounding objects or environments.

Having described various aspects of the main body **14** of the glove dispenser **2**, the glove dispenser **2** also may comprise a glove retention member **12**. With reference to FIGS. 5A, 5C, 6A, and 6B, the glove retention member **12** may comprise a first glove hanger **15** and a second glove hanger **16**. In various embodiments, the first glove hanger **15** and/or the second glove hanger **16** are each disposed extending normal (e.g., perpendicularly) from a face of the main body **14**. While various embodiments are depicted herein having a first glove hanger **15** and a second glove hanger **16**, it may be appreciated that one glove hanger, or three glove hangers, or four glove hangers, or any number of glove hangers may be implemented. In various embodiments, the first glove hanger **15** and the second glove hanger **16** are spaced equidistant from a line passing through the center of the main body **14** of the base (i.e., the X-Y plane). Moreover, the first glove hanger **15** and the second glove hanger **16** may be mirrors of one another, for example, as discussed

further wherein, each glove hanger may have a hanger angle **45** (FIG. 7A) whereby the glove hangers are both angled outward from a line passing through the center of the main body **14**, or whereby the glove hangers are angled at a hanger angle **45** (FIG. 7D) approximating a right angle from a line passing through the center of the main body **14**. In further embodiments, with reference to FIG. 5B, multiple glove retention members **12** may be positioned so that they share one or more glove hangers. For example, with momentary emphasis on FIG. 5B, two glove retention members **12** may share a centrally positioned second glove hanger **16**.

With reference now to FIGS. 4, 5A and C, and 6A-B, the support member **13** may comprise legs. For example, the support member **13** may comprise a first forward leg **20**, a second forward leg **22**, a first aft leg **24**, and a second aft leg **26**. The first forward leg **20** and the second forward leg **22** may be spaced along one face of the main body **14**, and the first aft leg **24** and the second aft leg **26** may be spaced along a second face of the main body **14**. These faces may be parallel, for example, parallel opposite sides of the main body **14**. With momentary reference to FIG. 9, in various embodiments, legs may be made in pairs, for example, the first forward leg **20** and the second forward leg **22** may be a pair, and the first aft leg **24** and the second aft leg **26** may be a pair. Each pair may comprise a single bent piece of metal, for example, a stiff metal wire. In various embodiments, each leg has a foot **50**. Alternatively, with reference to FIG. 5B, the support member **13** may comprise a first forward leg **20** and a second forward leg **22**. The support member **13** may further comprise an aft support bar **21** extending perpendicular to the first forward leg **20** and the second forward leg **22** and behind the main body **14**, eliminating the need for aft legs. The various legs may be removable, for instance, to permit compact shipping and storage.

In various embodiments, the foot **50** may comprise a circular disc. In one example, the foot **50** may be a suction cup to attach the legs to a flat surface. In another example, the foot **50** may be the same suction cup but may be reversible to provide a friction connection between the legs and the flat surface. Alternatively, the foot **50** may comprise an integral portion of a leg, for example the first forward leg **20**, the second forward leg **22**, the first aft leg **24** or the second aft leg **26**. Furthermore, in various embodiments, the foot **50** may be circular, or square, or oval, or trapezoidal, or may comprise any shape or combination of shapes configured to provide stability. The foot **50** may extend below the leg, for example, to diminish wobble caused by dimensional overconstraint of the support member **13** when resting on a surface, for example, a countertop. In various embodiments, the foot **50** is rubber, though it may be plastic or any other material suitable to provide support to the glove dispenser **2** and friction resistance to the surface on which it rests.

With continuing reference to FIGS. 4 and 6A-B and with additional reference to FIG. 9, the support member **13** may also comprise a support member base attachment element **28**. The support member base attachment element **28** may comprise a tab attached to a portion of the support member **13**. Further, the support member base attachment element **28** being a tab may comprise one or more holes **30** to facilitate connecting the tab to the main body **14**. In various embodiments, the one or more holes **30** correspond to an aperture disposed within the support member base attachment element **28**. In this manner, a fastener may be inserted to hold the two elements in mechanical communication. Alternatively, the support member base attachment element **28** may

comprise a plug, a stake, a glue pad, or any other mechanism intended to interface with the main body **14**.

In some embodiments, the support member base attachment element **28** may be a tab connected to the wire comprising a leg. In some embodiments, the legs are made in pairs, for example, the first forward leg **20** and the second forward leg **22** may be a pair comprising a single piece of bent wire, and the support member base attachment element **28** may be a tab connected to the wire proximate to one of the legs. In various embodiments, the support member base attachment element **28** comprises a pair of metal tabs each attached to a different portion of the support member **13**. For example, the support member base attachment element **28** may comprise a first tab attached to a first portion of the support member **13** and a second tab attached to a second portion of the support member **13**. Thus, a tab may be positioned near each of the legs, for example, the first portion may be proximate to the first forward leg **20** and the second portion may be proximate to the second forward leg **22**. Alternatively, the first portion may be proximate to the first aft leg **24** and the second portion may be proximate to the second aft leg **26**. Moreover, one or more support member base attachment element **28** may be associated with each leg or pair of legs.

With reference to FIGS. **5A-C**, **6A-B**, and **9**, in various embodiments, the main body **14** comprises a hanger interface plate **38** on the backside of the main body **14**. The hanger interface plate **38** may comprise a metal plate disposed in contact with the first glove hanger **15** and the second glove hanger **16**. The plate may limit the movement of the first glove hanger **15** and the second glove hanger **16**. For example, each glove hanger may be articulable through a plane parallel to a face of the main body **14**, for example, as discussed herein, a glove backstop face **34** of the main body **14**. However, the hanger interface plate **38** may restrict the movement of the glove hangers, for example, preventing downward movement of the glove hanger (e.g., movement in the negative Y direction). As a result, the hanger may be rigid in the downward direction, but when struck by hands or with a body part, the hangers may flex to reduce the risk of injury. Moreover, the flexing may reduce the risk that such inadvertent contact would break the glove dispenser **2**. The hanger interface plate **38** may be disposed in contact with both the first glove hanger **15** and the second glove hanger **16**, or with just one glove hanger, or with any number of glove hangers.

With reference to FIGS. **5A-C** and **6A-B**, in various embodiments, the glove backstop face **34** may provide a surface against which gloves may rest as they hang from the glove retention member **12**. The glove backstop face **34** may comprise a concave surface, for example at a top portion of the main body **14**. For example, the glove backstop face **34** may comprise a chamfered and/or curved face resembling a curve of the back of a human hand. In this manner, the glove backstop face **34** may enhance the ease with which a hand may be inserted into a glove attached to the glove retention member **12**. In various embodiments, glove backstop face **34** is planar. However, the glove backstop face **34** may comprise any shape whereby the user's hand may be more readily guided to access the glove attached to the glove retention member **12**.

Additionally, in various embodiments and with reference to FIGS. **5A-C** and **9**, the main body **14** may comprise vertical strengthening ribs **58** and horizontal strengthening ribs **60** for providing support and strength. The main body **14** may comprise two vertical strengthening ribs **58**, though any number of vertical strengthening ribs **58** may be imple-

mented. Further, the main body **14** may comprise three horizontal strengthening ribs **60**, though any number of horizontal strengthening ribs **60** may be implemented. The vertical strengthening rib **58** may comprise a unitary piece of material integral with the main body **14** and traversing a substantial length of the main body **14** parallel to the Y-axis. Similarly, the horizontal strengthening rib **60** may comprise a unitary piece of material integral with the main body **14** and traversing a length of the main body **14** parallel to the X-axis. At least one of the vertical strengthening ribs **58** and the horizontal strengthening ribs **60** may extend in the negative Z-direction, so that it forms a stringer running along a face of the main body **14**. In this manner, the ribs may ameliorate bending and may provide reinforcement to the glove dispenser **2**. The strengthening ribs **58**, **60** may comprise any element adapted to ameliorate bending so as to strengthen the main body **14** and enhance rigidity in the Y-Z plane.

With reference to FIGS. **5A-C**, **7A-B**, **7D-E**, and **9**, the glove retention member **12** may further comprise a first glove hanger aperture **40** connected to the first glove hanger **15** and a second glove hanger aperture **42** connected to the second glove hanger **16**. The first glove hanger aperture **40** and second glove hanger aperture **42** may individually comprise an aperture disposed in the glove backstop face **34** of the main body **14**. For example, an aperture may be disposed linearly outward and upward of a geometric center point of the glove backstop face **34**. In other words, the first and second glove hanger apertures **40**, **42** may be disposed in the upper left corner and upper right corner, respectively, of the glove backstop face **34**.

With reference to FIGS. **7A-B** and **7D-E**, in various embodiments, the first glove hanger aperture **40** may comprise a stop tab **41**. Similarly, the second glove hanger aperture **42** may also comprise a stop tab **41**. The stop tab **41** may be designed to resist motion of the hanger shaft **46** in the direction of the stop tab **41**. The stop tab **41** may be any structure by which movement of a hanger shaft **46** extending from the aperture may be constrained. For example, the stop tab **41** may comprise a boss extending from the circumference of the aperture toward the center of the aperture. The boss may be located at the negative most point of the aperture with respect to the Y-axis. Thus, the boss may be said to be located at the bottom of the aperture. The boss may be unitary with the main body **14** as illustrated in FIG. **5A-C**, or may be glued, sonically welded, or otherwise fixed in position. The boss may comprise a separate piece of material, for example, an insert configured to be placed in the aperture or may comprise a piece unitary with the main body **14** as illustrated in FIGS. **7B** and **7E**.

With reference to FIGS. **5A**, **6A-9**, the first glove hanger **15** and the second glove hanger **16** each may comprise a flexible base **44**, a hanger shaft **46**, and an end hook **48**. The flexible base **44** may be positioned within the first glove hanger aperture **40** of the main body **14**. The hanger shaft **46** may be inserted through the flexible base **44** and may extend outward in an X-axis direction. Further, the end hook **48** may comprise a bent portion of the hanger shaft **46** disposed at a distal end of the hanger shaft **46** with respect to the main body **14**. A proximate end of the hanger shaft **46**, with respect to the main body **14**, may be disposed within the flexible base **44**. In this manner, the hanger shaft **46** may be retained securely in connection to the main body **14** via the flexible base **44** inserted within the first glove hanger aperture **40** and/or the second glove hanger aperture **42**. However, the flexible base **44** may also be flexible so that the hanger shaft **46** is movable in response to external forces

11

exerted on the hanger shaft **46**, for example, by the user's hand. In various embodiments, the flexible base **44** permits the hanger shaft **46** to translate in the Y and Z directions, but not in the X direction.

With reference to FIG. **5B**, the first glove hanger **15** and the second glove hanger **16** each may comprise a hanger shaft **46**, and an end hook **48**. Thus, in various embodiments, the flexible base is omitted. The hanger shaft **46** may be inserted into the main body **14**, and may extend outward in an X-axis direction. Further, the end hook **48** may comprise a bent portion of the hanger shaft **46** disposed at a distal end of the hanger shaft **46** with respect to the main body **14**. A proximate end of the hanger shaft **46**, with respect to the main body **14**, may be disposed within the main body **14**, and/or may abut against a face of the main body **14** where it is secured by welding, gluing, bonding, or any other method. In this manner, the hanger shaft **46** may be retained securely in connection to the main body **14**.

In various embodiments and with specific reference to FIG. **8A**, the flexible base **44** may comprise a sleeve **62** and a shock absorber **64**. With specific reference to FIG. **8C**, the flexible base **44** may comprise a shock absorber **64**, but omit a sleeve **62** (compare FIG. **8A**). The shock absorber **64** may comprise a disc made from a flexible material, for example, rubber. Alternatively, the shock absorber **64** may comprise any shape adapted to fit in the aperture comprising the first glove hanger **15** and/or the second glove hanger **16**. The shock absorber **64** may comprise any material suitable to retain the hanger shaft **46**, yet permit flexibility. The sleeve **62** may comprise a hollow cylinder extending axially from the shock absorber **64**, for example, at its center and extending in the positive X direction. The sleeve **62** may comprise any element configured so that the hanger shaft **46** may extend through the sleeve **62**, terminating inside the shock absorber **64**. Thus, the flexible base **44** may permit movement of the hanger shaft **46** as discussed herein in response to flexing of the shock absorber **64**, yet may prevent the hanger shaft **46** from translating in the X direction via the frictional interaction between the sleeve **62** and the hanger shaft **46**.

In various embodiments and with specific reference to FIGS. **8B** and **8C**, the hanger shaft **46** may be bent or otherwise configured to facilitate feeding or dispensing of gloves. For example, a hanger shaft **46** may bend downwardly in order to facilitate gravitational feeding of gloves as the gloves are pulled from the hanger. Moreover, the bend of the shaft may cause a glove that is being dispensed to open so that a user's hand is more easily insertable. Furthermore, because of the bend in the hanger shaft **46**, the user is permitted significant latitude in how the user tugs on the glove when dispensing the glove. For instance, the user may pull downward or pull away from the dispenser or may pull in a variety of directions. Because the hanger shaft is bent, a tug in a variety of directions causes a force having a vector component substantially perpendicular to the main body **14**. In this manner, the bend in the hanger shaft **46** allows the glove to be torn away and the next glove staged in response to a variety of different tugs in different directions, by the user.

Moreover, the hanger shaft **46** may further comprise an upper retainer **51**. The upper retainer **51** may comprise an abrupt change in the diameter of the hanger shaft **46** whereby stored gloves may be prevented from gravity feeding until a force is exerted on them sufficient to translate them past this abrupt change in diameter of the hanger shaft **46**, for example by a user's hand. The hanger shaft **46** may further comprise a shaft sleeve **49**. Upper retainer **51** may be

12

integrally formed with shaft sleeve **49** and may be an edge of the shaft sleeve **49**. In this manner, the abrupt change in diameter of the hanger shaft **46** continues from the upper retainer **51** to the end hook **48**. As a result, the increased diameter may ameliorate unwanted movement of gloves by increasing the friction between the glove and the portion of the hanger shaft **46** covered by the shaft sleeve **49**. In other embodiments, no shaft sleeve **49** is present, for example, in embodiments wherein the hanger shaft **46** is formed from stamped sheet metal, or in embodiments according to FIG. **8C**.

With reference to FIG. **8C**, the hanger shaft **46** may comprise a widened retention portion **43**. The widened retention portion **43** may comprise a gradual change in the diameter of the hanger shaft **46** and may comprise a flattening of the shaft or otherwise comprise a change in the cross-sectional profile of the shaft. The widened retention portion **43** may be disposed between the shaft angle **39** and the end hook **48**. In this manner, stored gloves may be prevented from gravity feeding until a force is exerted on them sufficient to translate them past this change in shape and/or diameter of the hanger shaft **46**, for example by a user's hand. As a result, the change in shape and/or diameter may ameliorate unwanted movement of gloves by increasing the friction between the glove and the widened retention portion **43** of the hanger shaft **46**. Moreover, when multiple gloves **1** are suspended from the hanger shaft **46**, such as when an entire package of gloves **1** is suspended, the bulk of the multiple gloves may cause them to expand as a group over the widened retention portion **43**. The distribution of the gloves may be enhanced by the gradual change in the cross-sectional profile of the shaft along the length of the widened retention portion **43**.

As briefly mentioned above, the hanger shaft **46** may comprise a shaft angle **39**. A shaft angle **39** may comprise a bend in the hanger shaft **46**. For example, a hanger shaft **46** may extend away from the main body **14** substantially perpendicular to a face of the main body **14**. At the shaft angle **39**, the hanger shaft **46** may transition to also extend downwardly and away from the face of the main body **14**.

Returning focus to the glove hanger and referencing FIGS. **5A-9**, the first glove hanger **15** and the second glove hanger **16** may each comprise an end hook **48** disposed at the distal end of the hanger shaft **46**. The end hook **48** may comprise a C-shape bent portion of the hanger shaft **46**. Alternatively, the end hook **48** may comprise a U-shaped bent portion of the hanger shaft **46**. Furthermore, the end hook **48** may comprise an upturned bent portion of the hanger shaft **46**. In various embodiments, the end hook **48** may further comprise a retention bump **47** (FIG. **7C**) extending from a surface of the hanger shaft **46** and enhancing frictional engagement between the hanger shaft **46** and an item to be hanged from the hanger shaft **46**, for example, a glove. In various embodiments, the end hook is shaped to resemble a triangle so that the end hook **48** is wider at the outermost edge than where it unites with the hanger shaft **46**. In this manner, the frictional engagement may be increased between the hanger shaft **46** and an item to be hanged from the hanger shaft **46**, for example, a glove. As a result, the item to be hanged from the hanger shaft **46** may be prevented from inadvertently falling off of the end hook **48**, for example, in response to a wind or inadvertent brushing by a person. The end hook **48** may comprise a thickened portion of the hanger shaft **46**, or may comprise any shape configured to provide increased frictional engagement between the hanger shaft **46** and an item to be hanged from the hanger shaft **46**, for example, a glove.

13

Moreover, with reference to FIGS. 7A and 7D, the end hook 48 may be set at a selected angle, referred to herein as a hanger angle 45, which may be set directly upward, outward, or inward relative to the center of the main body 14. The hanger angle 45 may comprise an angle between the Z-axis and a line extending through and parallel to the end hook 48 of the hanger shaft 46. For example, the hanger shaft 46 may be positioned so that the end hook 48 extends coincident with a line disposed at the hanger angle 45 above the X-axis. In this manner, the end hook 48 may extend upward and outward (e.g., in the Y and Z direction) from the center of the main body 14.

In various embodiments, the first glove hanger 15 has a hanger angle 45 and the second glove hanger 16 also has a separate hanger angle 45. In various embodiments, each hanger angle 45 may comprise an angle having the same angular magnitude. The first glove hanger 15 may have an hanger angle 45 comprising an angle between the Z-axis and a line extending through the end hook 48 of the hanger shaft 46 wherein the line is oriented above (in the positive Y direction) the Z-axis at the angle. Similarly, the second glove hanger 16 may have a hanger angle 45 comprising an angle between the Z-axis and a line extending through the end hook 48 of the hanger shaft 46 wherein the line is oriented above (in the positive Y direction) the Z-axis at the angle. In this manner, each end hook 48 may point upward and outward from the center of the main body 14. The hanger angle 45 may comprise a 45 degree angle (FIG. 7A), or a 90 degree angle (FIG. 7D) or any desired angle.

Now, having discussed various aspects of the glove dispenser 2, the main body 14 may be configured in various ways to permit the glove dispenser 2 to be mounted and oriented differently, or for multiple glove dispensers 2 to be joined together. For example, in various embodiments and with reference to FIGS. 10-14, the glove dispenser 2 may be configured to hang from a surface, such as a wall (illustrated in FIG. 10), the glove dispenser 2 may be configured to be joined together back-to-back with an opposite facing a glove dispenser 2 (illustrated in FIG. 11A-B), the glove dispenser 2 may be singular and have legs (illustrated in FIG. 12), or the glove dispenser 2 may be configured to be joined side to side with a similarly facing glove dispenser 2 (illustrated in FIGS. 13A-B and 14A-B). As one may appreciate, the glove dispenser 2 may be reconfigurable to be mounted or oriented in a variety of ways and aspects of various embodiments and configurations may be combined. For example, a kit of parts may be provided to permit the glove dispenser 2 to be reconfigured variously.

For example, in various embodiments, with reference to FIG. 10, the main body 14 may comprise a hanging bracket 52. The hanging bracket 52 may be disposed in the Y-Z plane along a face of the main body 14, for example, along the back side of main body 14 opposite the glove retention member 12. In various embodiments, the hanging bracket 52 is a metal tab, although the hanging bracket 52 may be any element adapted to enable the main body 14 to be attached to a surface, for example, screwed, nailed, adhered, suctioned, or otherwise fastened to a wall.

To facilitate the back-to-back variation, in various embodiments, with reference to FIGS. 11A, 11B, and 12, the main body 14 may comprise a back-to-back stand attachment member 54. For example, the glove dispenser 2 may have a member that permits the glove dispenser 2 to be joined with another glove dispenser 2 wherein the glove retention member 12 of each glove dispenser 2 is oriented in an opposite direction. In this manner, the glove dispensers 2

14

may be said to be back to back and a user may put gloves on both hands simultaneously.

As shown in the backside view of FIG. 12, in various embodiments, a back-to-back stand attachment member 54 comprises an aperture 66 and a back-to-back connector 68. The aperture 66 may be positioned on the backside of the main body 14. In various embodiments, more than one aperture 66 is positioned around a perimeter of the main body 14. A back-to-back connector 68 may comprise a plug adapted to fit in the aperture 66, being retained by friction to the aperture, and extend therefrom. For example, the back-to-back connector 68 may be a cylinder. In various embodiments, a second glove dispenser 2 also having similarly spaced apertures 66 may be positioned so that the back-to-back connectors 68 align with corresponding similarly spaced apertures 66. Thus, the two glove dispensers 2 may be joined together by the insertion of back-to-back connectors 68 into the apertures 66 of both the glove dispensers 2.

To facilitate the side-by-side variation, with reference to FIGS. 13A-B and 14A-B, in various embodiments, a side-by-side stand attachment member 56 comprises an aperture 70 and a side-by-side tab 72. The aperture 70 may be positioned on the backside of the main body 14. In various embodiments, more than one aperture 70 is positioned around a perimeter of the main body 14. In various embodiments, the locations of aperture 70 may be the same as the locations of aperture 66. The side-by-side tab 72 may comprise a pair of plugs (a first plug and a second plug) joined together and each adapted to fit in an aperture 70, being retained by friction to the aperture, and extend therefrom. For example, the side-by-side tab 72 may comprise a planar member comprising a face with two cylindrical plugs projecting outward in the same direction. One such plug may be inserted in an aperture 70 of a first glove dispenser 2 and the other plug may be inserted into an aperture 70 of a second glove dispenser 2. Thus, in various embodiments, the second glove dispenser 2 also having similarly spaced apertures 70 may be positioned so that the side-by-side tabs 72 align with the corresponding similarly spaced apertures 70. Thus, the two glove dispensers 2 may be joined together by the insertion of side-by-side tabs 72 into the apertures 70 of both glove dispensers 2. The glove dispensers 2 may be positioned adjacently with the face of each glove dispenser 2 facing in the same direction. In this manner, the glove dispensers 2 may be positioned so that a user may put gloves on both hands simultaneously.

Now, having described various components of various exemplary embodiments of the glove dispenser 2, the glove dispenser 2 may be manufactured from various materials. In one exemplary embodiment, the glove dispenser 2 may comprise metal, plastic, or a combination thereof. For example, the glove dispenser 2 may comprise metal, such as aluminum. Alternatively, the glove dispenser 2 may comprise metal, such as titanium, steel, or stainless steel, though it may alternatively comprise numerous other materials configured to provide support, such as, for example, fiber-glass composite, ceramic, ceramic matrix composite, plastics, polymers, alloys, austenitic nickel-chromium-based alloys, glass, binder, epoxy, polyester, acrylic or any material or combination of materials having a desired strength, stiffness, density, weight, or flexibility sufficient to maintain resiliency during use. In various embodiments, various portions of the glove dispenser 2 as disclosed herein are made of different materials or combinations of materials, and/or may comprise coatings.

In various embodiments, the glove dispenser 2 may comprise multiple materials, or any material configuration

15

suitable to enhance or reinforce the resiliency and/or support of the glove dispenser **2** when subjected to wear in an operating environment or to satisfy other desired weight, size, cost, chemical, physical, or biological properties, for example nonreactivity, light weight, load capacity, and heat tolerance. For example, various components may comprise metal while other components may comprise plastics and/or rubber.

In various embodiments, while the glove dispensers **2** described herein have been described in the context of glove support; however, one will appreciate in light of the present disclosure, that the apparatuses described herein, for example, the glove dispensers **2** may be used in connection with various other applications, for example in connection with various glove applications and dispensing applications.

In various embodiments, the disposable gloves **1** described herein may be packaged for shipping. For example, with reference to FIGS. **15A-B**, a set of multiple disposable gloves **1** may be packaged within a sanitary sealed film glove package **1500**. The sanitary sealed film glove package **1500** may comprise a forward face **1501** and an aft face **1504**. The forward face **1501** may comprise a film that is aligned to the outermost glove in the set and the aft face **1504** may comprise a film that is aligned to the innermost glove in the set. With momentary reference to FIG. **3B**, the gloves **1** in the set may each comprise tear points **8**, as previously discussed. At least one of the forward face **1501** and the aft face **1504** may comprise a metallic ink printed on a position that is aligned with a tear point **8** when the gloves are packaged within the sanitary sealed film glove package **1500**. The forward face **1501** and the aft face **1504** may be pressed together so that they contact at the tear point **8**, for example, through an aperture of the tear point **8**. The sanitary sealed film glove package **1500** and gloves **1** may be exposed to RF energy, for example, during RF welding, so that the metallic ink heats and causes the forward face **1501** and the aft face **1504** to weld and/or melt together through the tear point **8**. In this manner, the sanitary sealed film glove package **1500** may be secured around the gloves **1** and may be retained in position relative to them.

The sanitary sealed film glove package **1500** may further comprise hanger slits **1503** comprising cuts, perforations, and/or apertures disposed within the sanitary sealed film glove package **1500** and aligned to the interconnection points **4** of the gloves **1**. Thus, the entire package may hang on the glove dispenser **2**. The sanitary sealed film glove package **1500** may further comprise grip points **1502** where the user may grasp the sanitary sealed film glove package **1500** and compress the sanitary sealed film glove package **1500** between one's fingers, without grasping the gloves **1** disposed inside the sanitary sealed film glove package **1500**. In various embodiments, the grip points **1502** comprise the lower corners of the package nearest the fingers of the gloves **1**. The package may be torn away by pulling the package downward after grasping a grip point **1502**. A strategic perforation may be disposed along the upper edge of the package, or alternatively, the upper edge of the package may be open. The package may tear along this perforation, if present, so that the package may be torn away.

The gloves **1** and/or sanitary sealed film glove package **1500** may be manufactured from various materials. In one exemplary embodiment, the gloves **1** and/or sanitary sealed film glove package **1500** may comprise plastics, silicones, latex, or a combination thereof. For example, the gloves **1** and/or sanitary sealed film glove package **1500** may comprise thermoplastic aliphatic polyester, such as polylactide (PLA), or may comprise other thermoplastics, such as

16

acrylonitrile butadiene styrene (ABS) plastic, or may comprise any plastic. The gloves **1** and or sanitary sealed film glove package **1500** may comprise a PLA material made from corn-based resin, or starch-based resin, or resin derived from petroleum or non-petroleum sources. The gloves **1** and/or sanitary sealed film glove package **1500** may comprise polyethylene, nitrile, vinyl, latex, and/or any other suitable material. The gloves **1** and/or sanitary sealed film glove package **1500** may comprise numerous other materials configured to provide support, such as, for example, fiber-glass composite, ceramic, ceramic matrix composite, plastics, polymers, glass, binder, epoxy, polyester, acrylic or any material or combination of materials having a desired strength, stiffness, density, weight, or flexibility sufficient to maintain resiliency during use. In various embodiments, various portions of the gloves **1** and/or sanitary sealed film glove package **1500** as disclosed herein are made of different materials or combinations of materials, and/or may comprise coatings.

In various embodiments, the gloves **1** and or sanitary sealed film glove package **1500** may comprise multiple materials, or any material configuration suitable to enhance or reinforce the resiliency and/or support of the gloves **1** and/or sanitary sealed film glove package **1500** when subjected to wear in an operating environment or to satisfy other desired weight, size, cost, chemical, physical, or biological properties, for example nonreactivity, light weight, load capacity, and heat tolerance. For example, various components may comprise plastic while other components may comprise rubber.

Benefits, other advantages, and solutions to problems have been described herein with regard to specific embodiments. Furthermore, the connecting lines shown in the various figures contained herein are intended to represent exemplary functional relationships and/or physical couplings between the various elements. It should be noted that many alternative or additional functional relationships or physical connections may be present in a practical system. However, the benefits, advantages, solutions to problems, and any elements that may cause any benefit, advantage, or solution to occur or become more pronounced are not to be construed as critical, required, or essential features or elements of the inventions. Furthermore, any reference to singular includes plural embodiments, and any reference to more than one component or step may include a singular embodiment or step. Also, any reference to attached, fixed, connected or the like may include permanent, removable, temporary, partial, full and/or any other possible attachment option. Additionally, any reference to without contact (or similar phrases) may also include reduced contact or minimal contact. The scope of the inventions is accordingly to be limited by nothing other than the appended claims, in which reference to an element in the singular is not intended to mean "one and only one" unless explicitly so stated, but rather "one or more." Moreover, where a phrase similar to "at least one of A, B, or C" is used in the claims, it is intended that the phrase be interpreted to mean that A alone may be present in an embodiment, B alone may be present in an embodiment, C alone may be present in an embodiment, or that any combination of the elements A, B and C may be present in a single embodiment; for example, A and B, A and C, B and C, or A and B and C. Different cross-hatching is used throughout the figures to denote different parts but not necessarily to denote the same or different materials.

Systems, methods and apparatus are provided herein. In the detailed description herein, references to "one embodi-

17

ment”, “an embodiment”, “various embodiments”, etc., indicate that the embodiment described may include a particular feature, structure, or characteristic, but every embodiment may not necessarily include the particular feature, structure, or characteristic. Moreover, such phrases are not necessarily referring to the same embodiment. Further, when a particular feature, structure, or characteristic is described in connection with an embodiment, it is submitted that it is within the knowledge of one skilled in the art to affect such feature, structure, or characteristic in connection with other embodiments whether or not explicitly described. After reading the description, it will be apparent to one skilled in the relevant art(s) how to implement the disclosure in alternative embodiments.

Furthermore, no element, component, or method step in the present disclosure is intended to be dedicated to the public regardless of whether the element, component, or method step is explicitly recited in the claims. No claim element herein is to be construed under the provisions of 35 U.S.C. 112(f), unless the element is expressly recited using the phrase “means for.” As used herein, the terms “comprises,” “comprising,” or any other variation thereof, are intended to cover a non-exclusive inclusion, such that a process, method, article, or apparatus that comprises a list of elements does not include only those elements but may include other elements not expressly listed or inherent to such process, method, article, or apparatus.

The invention claimed is:

1. A disposable glove comprising:
 - a opening for hand entry having a first opening edge and a second opening edge;
 - a first interconnection point located near the first opening edge and comprising a tab from a punch-out of a hole, wherein the first interconnection point attaches the disposable glove to a first adjacent disposable glove; and
 - a second interconnection point located near the second opening edge and comprising a tab from a punch-out of a hole, wherein the second interconnection point attaches the disposable glove to a second adjacent disposable glove, wherein the disposable glove is positioned between the first adjacent disposable glove and the second adjacent disposable glove.
2. The disposable glove of claim 1, further comprising at least one gusset configured to increase a size of the opening for hand entry.
3. The disposable glove of claim 1, further comprising two tear points.
4. The disposable glove of claim 1, further comprising a plurality of tack points along an inside perimeter of the disposable glove.
5. The disposable glove of claim 1, wherein the first interconnection point and the second interconnection point attaches via heat sealing, an adhesive, an interlock tab, or a combination thereof.
6. The disposable glove of claim 1, wherein the disposable glove hangs from a glove dispenser, and wherein the glove dispenser comprises a first glove hanger and a second glove hanger.
7. The disposable glove of claim 6, wherein the first glove hanger and the second glove hanger each pass through a hanger opening in the disposable glove.
8. The disposable glove of claim 7, wherein the hanger opening is formed by the punch-out of the hole.
9. A disposable glove dispensing system comprising:
 - a glove dispenser comprising a main body connected to a first glove hanger and a second glove hanger, the main

18

body further comprising a first glove hanger aperture and a second glove hanger aperture wherein the first glove hanger comprises a flexible base comprising a shock absorber disposed within the first glove hanger aperture and the second glove hanger comprises a flexible base comprising a shock absorber disposed within the second glove hanger aperture.

10. The disposable glove dispensing system of claim 9, the glove dispenser further comprising a main body connected to the first glove hanger and the second glove hanger, and further comprising a support member connected to the main body.

11. The disposable glove dispensing system of claim 10, wherein the first glove hanger and the second glove hanger extend outwardly from a face of the main body.

12. The disposable glove dispensing system of claim 9, the glove dispenser further comprising a main body connected to the first glove hanger and the second glove hanger, the main body further comprising a hanging bracket configured to be attached to a surface.

13. The disposable glove dispensing system of claim 10, wherein the support member comprises:

a first forward leg and a second forward leg spaced along a first face of the main body, and

a first aft leg and a second aft leg spaced along a second face of the main body,

wherein the first face of the main body and the second face of the main body comprise parallel opposite faces.

14. The disposable glove dispensing system of claim 10, wherein the main body further comprises a first glove hanger aperture and a second glove hanger aperture, and

wherein the first glove hanger is disposed within the first glove hanger aperture and the second glove hanger is disposed within the second glove hanger aperture.

15. The disposable glove dispensing system of claim 14, wherein the first glove hanger aperture comprises a first stop tab comprising a boss extending from a circumference of the first glove hanger aperture toward a center of the first glove hanger aperture whereby movement of the first glove hanger is constrained, and

wherein the second glove hanger aperture comprises a second stop tab comprising a boss extending from a circumference of the second glove hanger aperture toward the center of the second glove hanger aperture whereby movement of the second glove hanger is constrained.

16. The disposable glove dispensing system of claim 15, wherein the first glove hanger is constrained from moving in a downward direction and wherein the second glove hanger is constrained from moving in the downward direction.

17. The disposable glove dispensing system of claim 15, wherein the first glove hanger comprises:

a flexible base comprising:

a shock absorber disposed within the first glove hanger aperture; and

a sleeve comprising a hollow cylinder extending axially from the shock absorber;

wherein a hanger shaft is disposed within the sleeve and extending axially from the shock absorber; and an end hook comprising a bent portion of the hanger shaft disposed at a distal end of the hanger shaft.

18. The disposable glove dispensing system of claim 15, wherein the first glove hanger comprises:

a flexible base comprising a shock absorber disposed within the first glove hanger aperture;

a hanger shaft disposed within the shock absorber and extending axially from the shock absorber; and

19

an end hook comprising a bent portion of the hanger shaft disposed at a distal end of the hanger shaft.

19. The disposable glove dispensing system of claim 10, wherein the main body comprises a contoured face.

20. The disposable glove dispensing system of claim 10, wherein the main body comprises a back-to-back stand attachment member comprising:

an aperture positioned on a backside of the main body; and

a back-to-back tab comprising a plug inserted into the aperture and extending outward from the aperture and adapted to join a second glove dispenser having a similar aperture.

21. The disposable glove dispensing system of claim 10, wherein the main body comprises a side-to-side stand attachment member comprising:

an aperture positioned on a backside of the main body; and

a side-to-side tab comprising a planar member comprising a face with a first plug and a second plug projecting outward in the same direction,

wherein the first plug is positioned in the aperture, and wherein the second plug is configured to be positioned in a similar aperture of a second glove dispenser.

22. The disposable glove dispensing system of claim 17, wherein the hanger shaft comprises a retention bump whereby a first opening edge of a glove may be retained aft of the retention bump and a second opening edge of the glove may be disposed forward of the retention bump.

23. The disposable glove dispensing system of claim 17, wherein the hanger shaft comprises a first retention bump disposed on the hanger shaft and a second retention bump disposed on the hanger shaft axially outward of the first retention bump whereby a first opening edge of a glove may be retained aft of the first retention bump and a second opening edge of the glove may be disposed forward of the second retention bump.

24. The disposable glove dispensing system of claim 18, wherein the hanger shaft comprises:

20

a shaft angle transition comprising a downward bend in the hanger shaft; and

a widened retention portion disposed between the shaft angle transition and the end hook,

wherein a first opening edge of a glove may be retained aft of the widened retention portion and a second opening edge of the glove may be disposed forward of the widened retention portion.

25. A method of dispensing a disposable glove comprising:

opening the disposable glove comprising:

a first opening edge;

a second opening edge;

a first interconnection point located near the first opening edge, wherein the first interconnection point is configured to attach the disposable glove to a first adjacent disposable glove; and

a second interconnection point located near the second opening edge, wherein the second interconnection point attaches the disposable glove to a second adjacent disposable glove;

inserting a hand into the disposable glove;

tearing the second interconnection point; and

removing the disposable glove from the glove dispenser.

26. The method of dispensing a disposable glove according to claim 25, wherein the first interconnection point and the second interconnection point each comprise a tab from a punch-out of a hole.

27. A disposable glove comprising:

an opening for hand entry having a first opening edge and a second opening edge; and

a first interconnection point located near the first opening edge and comprising a tab from a punch-out of a hole configured to receive a first glove hanger, wherein the first interconnection point is configured to attach the disposable glove to a first adjacent disposable glove.

* * * * *