



US009523962B2

(12) **United States Patent**
Maruyama et al.

(10) **Patent No.:** **US 9,523,962 B2**

(45) **Date of Patent:** **Dec. 20, 2016**

(54) **ELECTRONIC TIMEPIECE**

(56) **References Cited**

(71) Applicant: **CASIO COMPUTER CO., LTD.**,
Shibuya-ku, Tokyo (JP)

(72) Inventors: **Hirohisa Maruyama**, Fuchu (JP);
Jyunichi Hirokawa, Akishima (JP)

(73) Assignee: **CASIO COMPUTER CO., LTD.**,
Tokyo (JP)

(*) Notice: Subject to any disclaimer, the term of this
patent is extended or adjusted under 35
U.S.C. 154(b) by 0 days.

U.S. PATENT DOCUMENTS

4,681,460	A *	7/1987	Nishimura	G04G 9/0076
					368/21
5,007,033	A *	4/1991	Kubota	G04G 9/0076
					368/21
5,319,581	A *	6/1994	Sakata	G06F 1/14
					708/111
8,817,579	B2 *	8/2014	Scott	G04G 21/04
					368/21
2003/0081507	A1 *	5/2003	Kitazawa	G04G 9/0076
					368/21

FOREIGN PATENT DOCUMENTS

JP 2009118403 A 5/2009

* cited by examiner

Primary Examiner — Vit W Miska

(74) *Attorney, Agent, or Firm* — Holtz, Holtz & Volek PC

(21) Appl. No.: **15/046,117**

(22) Filed: **Feb. 17, 2016**

(65) **Prior Publication Data**

US 2016/0252885 A1 Sep. 1, 2016

(30) **Foreign Application Priority Data**

Feb. 27, 2015 (JP) 2015-037853

(51) **Int. Cl.**

G04G 9/00 (2006.01)

G04R 20/14 (2013.01)

(52) **U.S. Cl.**

CPC **G04G 9/0076** (2013.01); **G04R 20/14**
(2013.01)

(58) **Field of Classification Search**

CPC G04G 5/00; G04G 5/007; G04G 9/0076;
G04R 20/14

See application file for complete search history.

(57) **ABSTRACT**

An electronic timepiece that displays time based on city data related to the time of a city includes: a second home time storage area and a third world time storage area that store additional city data related to the time of an additional city transmitted from an external device; a storage area other than the second home time storage area and the third world time storage area; and a processing unit that clears the additional city data stored in the second home time storage area and the third world time storage area when selected data is switched from the additional city data stored in the second home time storage area and the third world time storage area to the city data stored in the storage area.

16 Claims, 11 Drawing Sheets

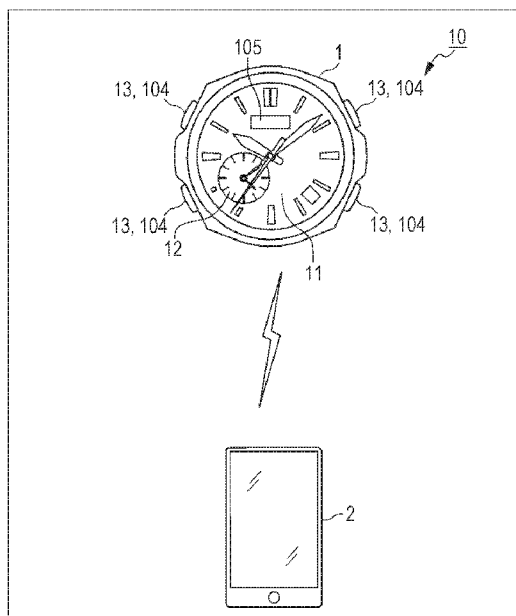

FIG. 1

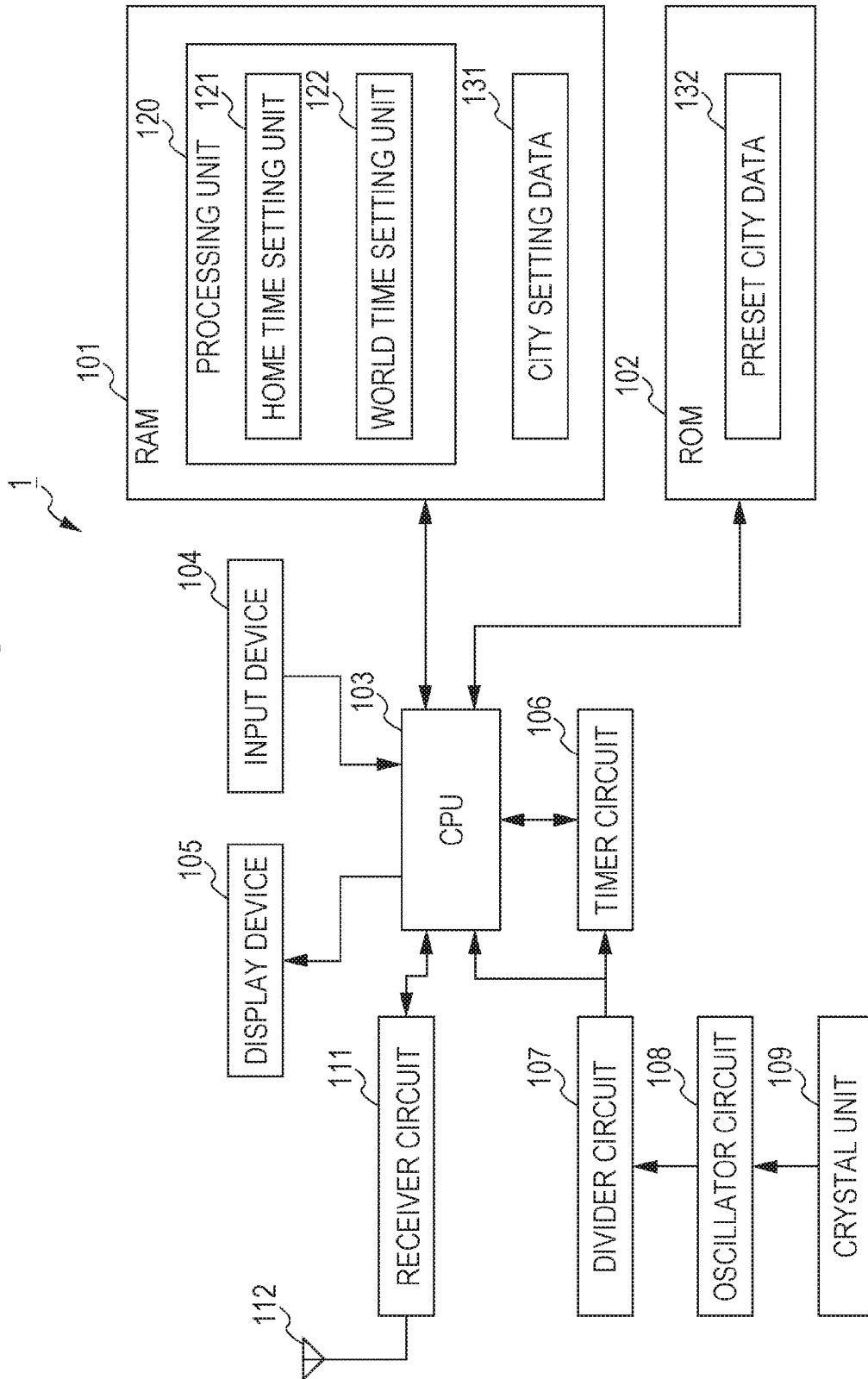

FIG. 2

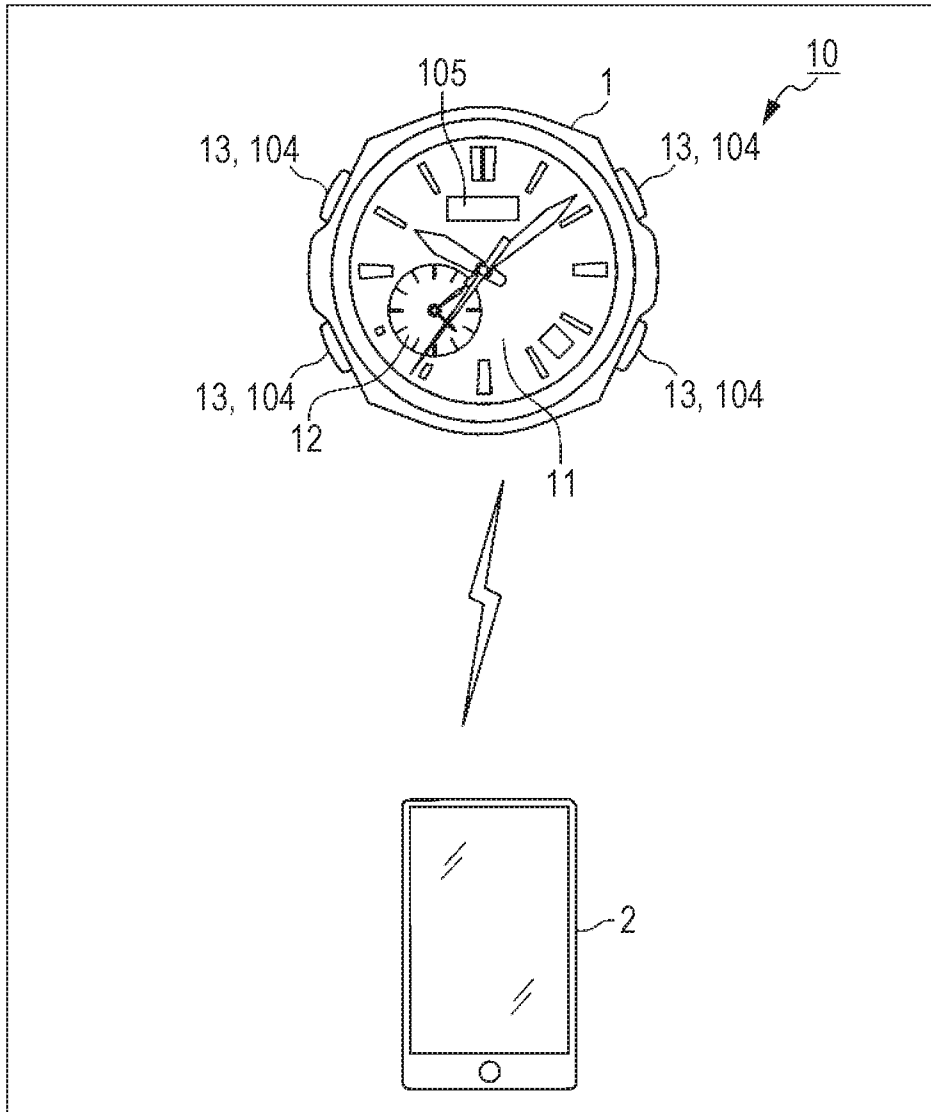

FIG. 3

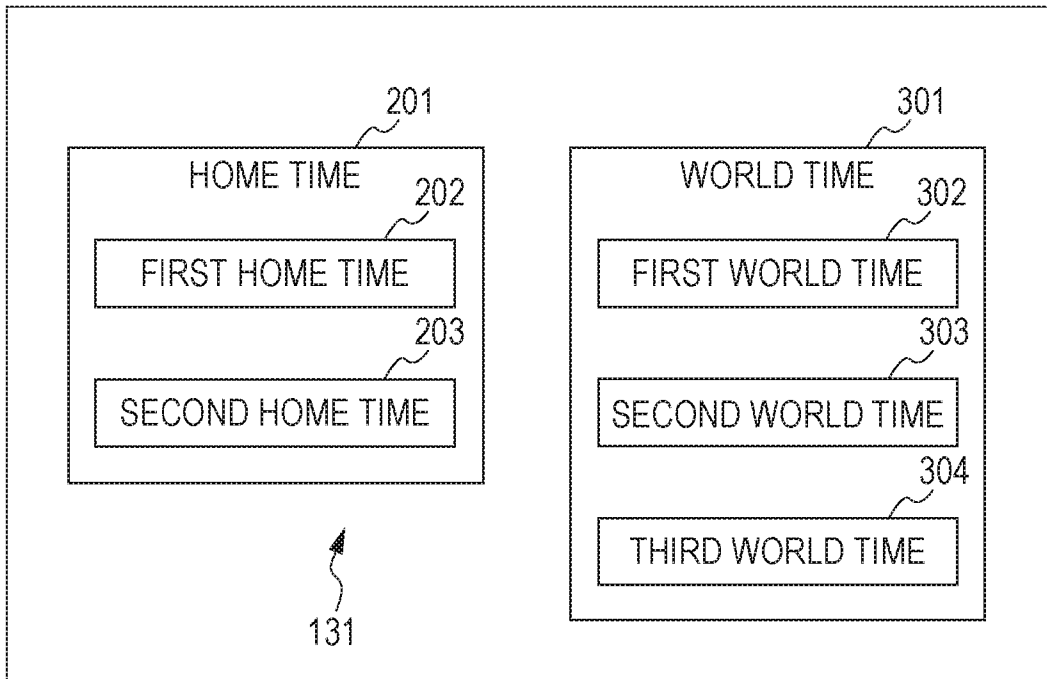

FIG. 4

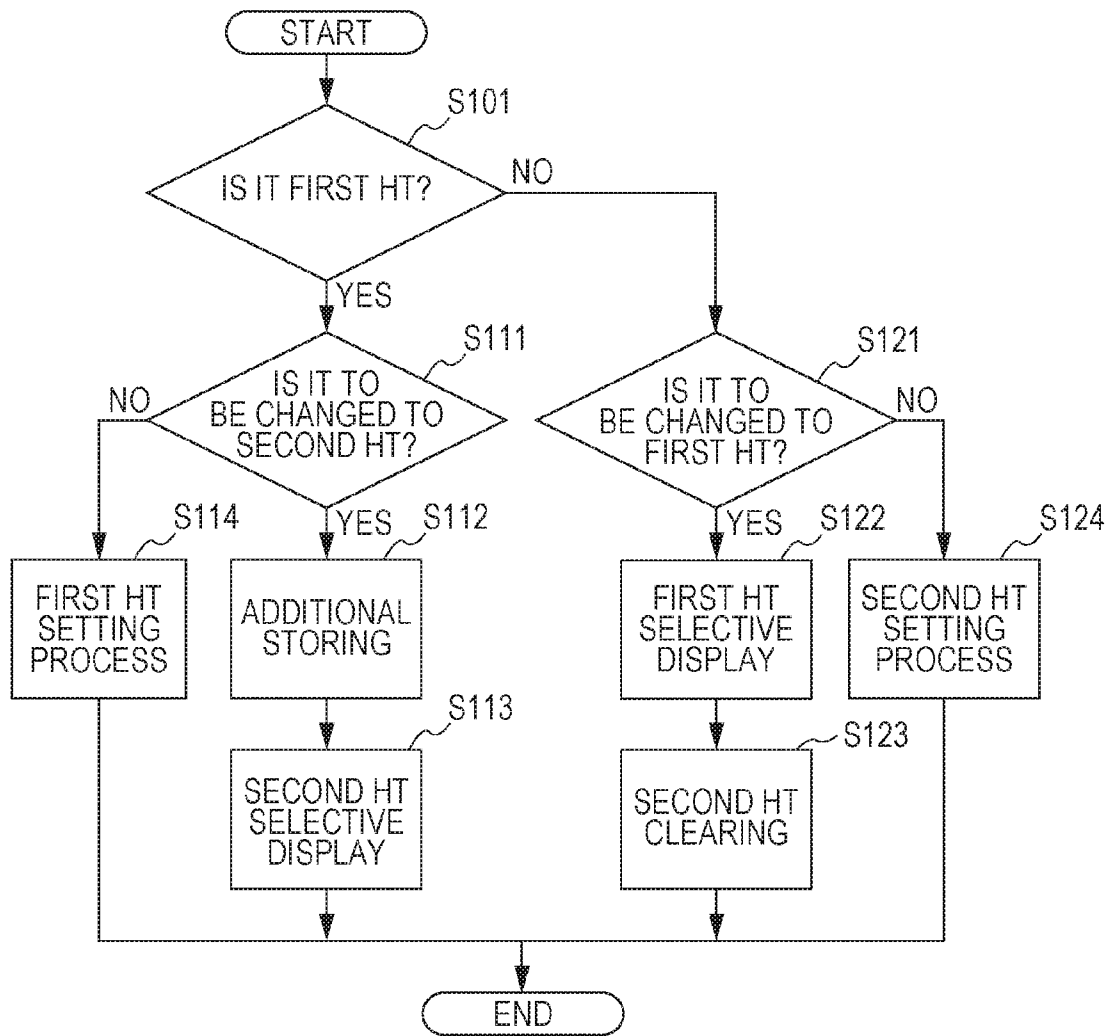

FIG. 5

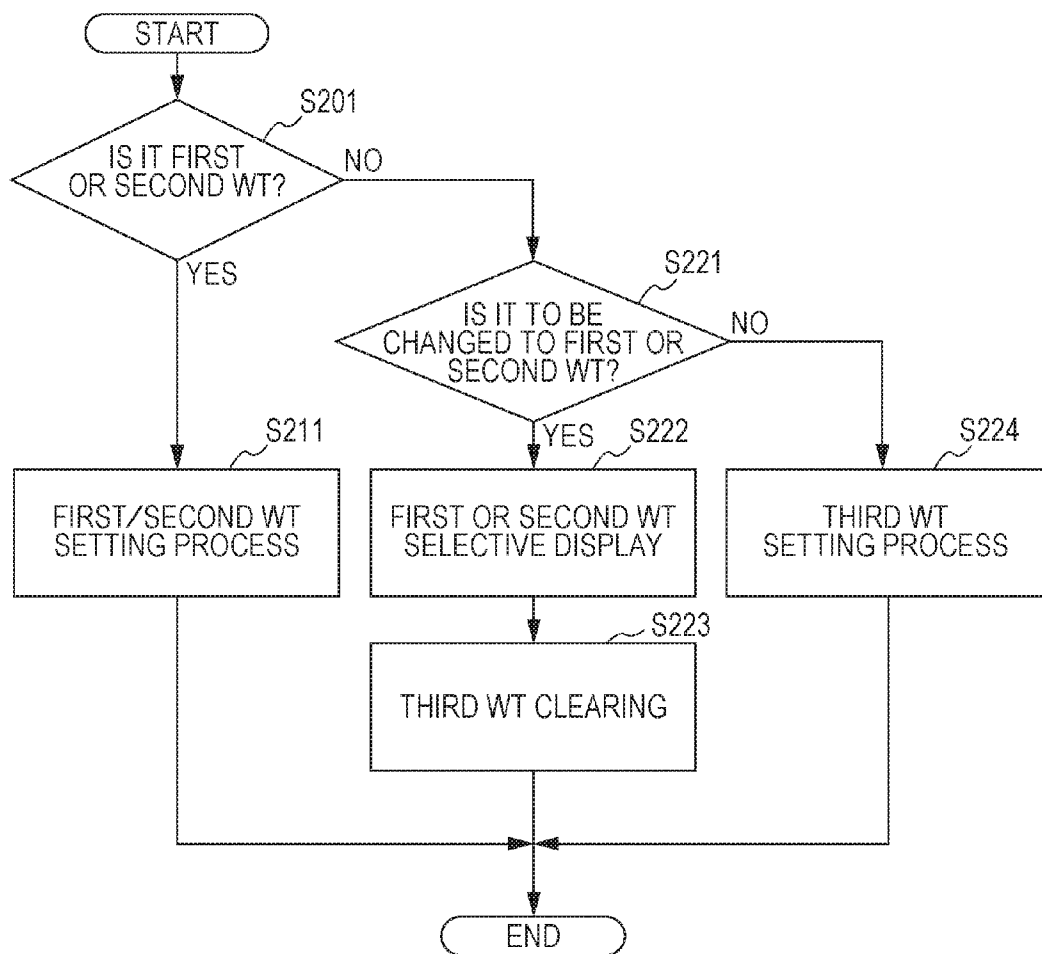

FIG. 6A

FIRST HOME TIME	SECOND HOME TIME
(UNDETERMINED)	◆ CITY C

FIG. 6B

FIRST HOME TIME	SECOND HOME TIME
CITY A	(CLEARED)

FIG. 7A

FIRST WORLD TIME	SECOND WORLD TIME	THIRD WORLD TIME
(UNDETERMINED)	◆ CITY B	◆ CITY C

FIG. 7B

FIRST WORLD TIME	SECOND WORLD TIME	THIRD WORLD TIME
CITY A	◆ CITY B	(CLEARED)

FIG. 8A

FIRST WORLD TIME	SECOND WORLD TIME	THIRD WORLD TIME
(UNDETERMINED)	◆ CITY B	◆ CITY C

FIG. 8B

FIRST WORLD TIME	SECOND WORLD TIME	THIRD WORLD TIME
(UNDETERMINED)	◆ CITY B	(CLEARED)

FIG. 9

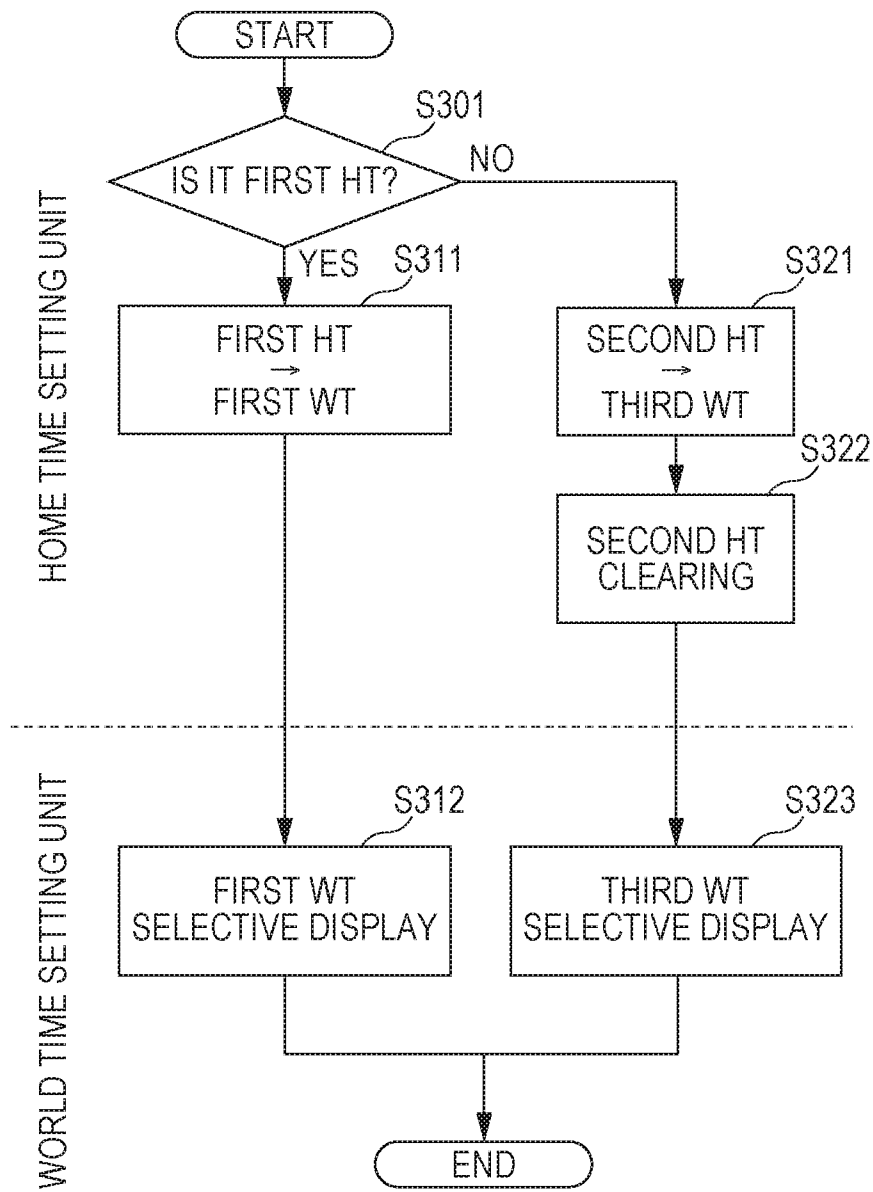

FIG. 10

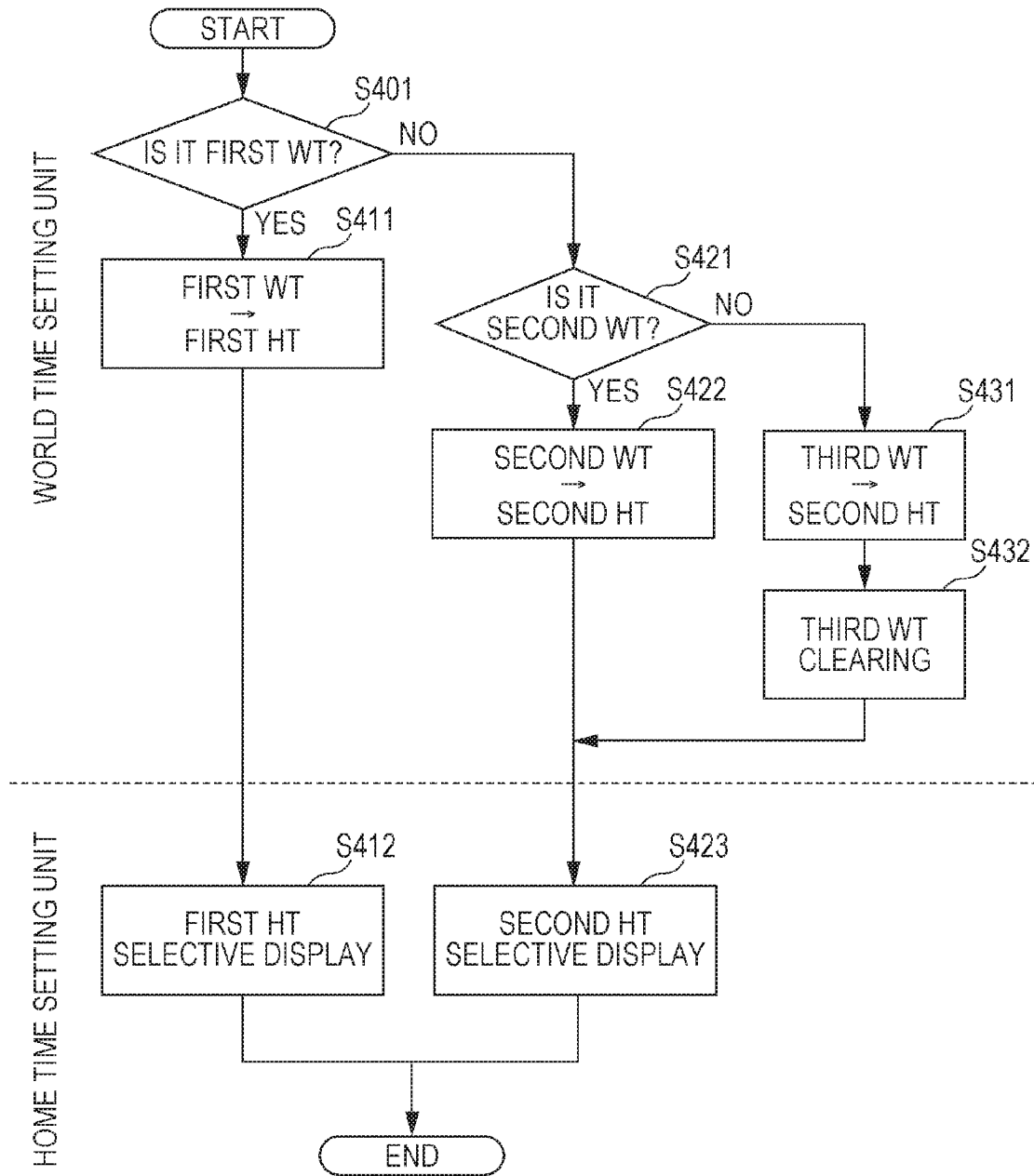

FIG. 11A

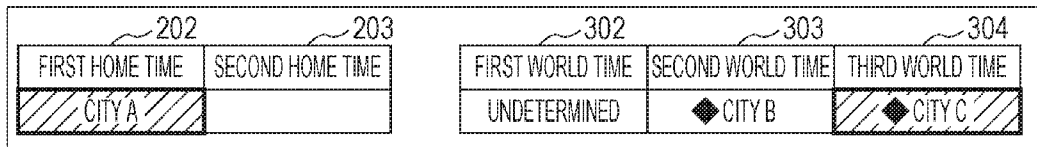

FIG. 11B



FIG. 12A

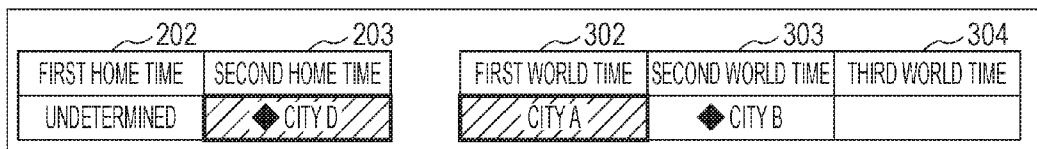

FIG. 12B

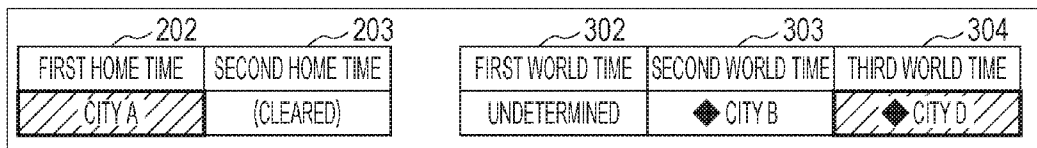

FIG. 13A

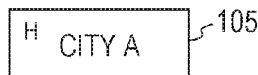

FIG. 13B

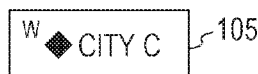

FIG. 14

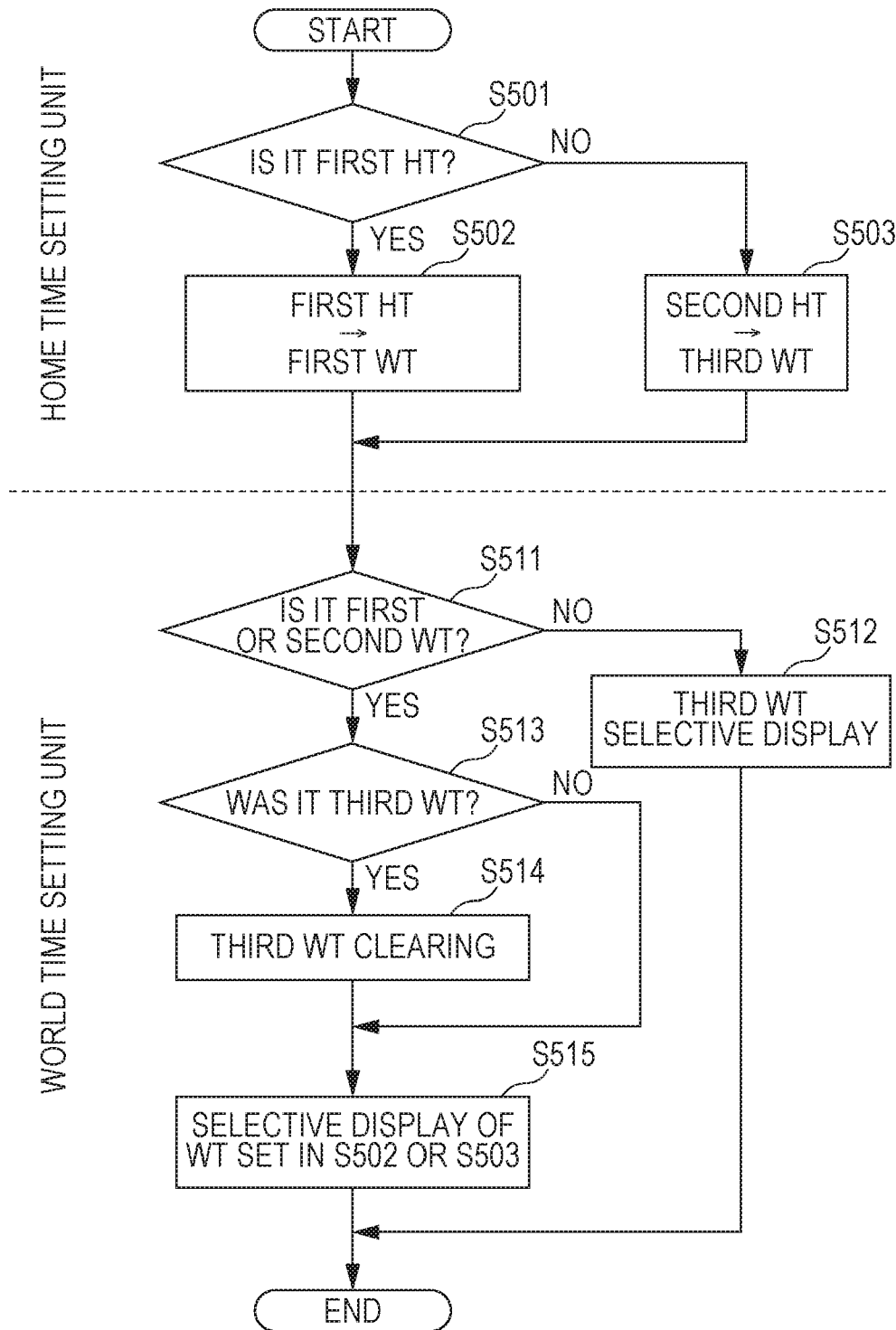
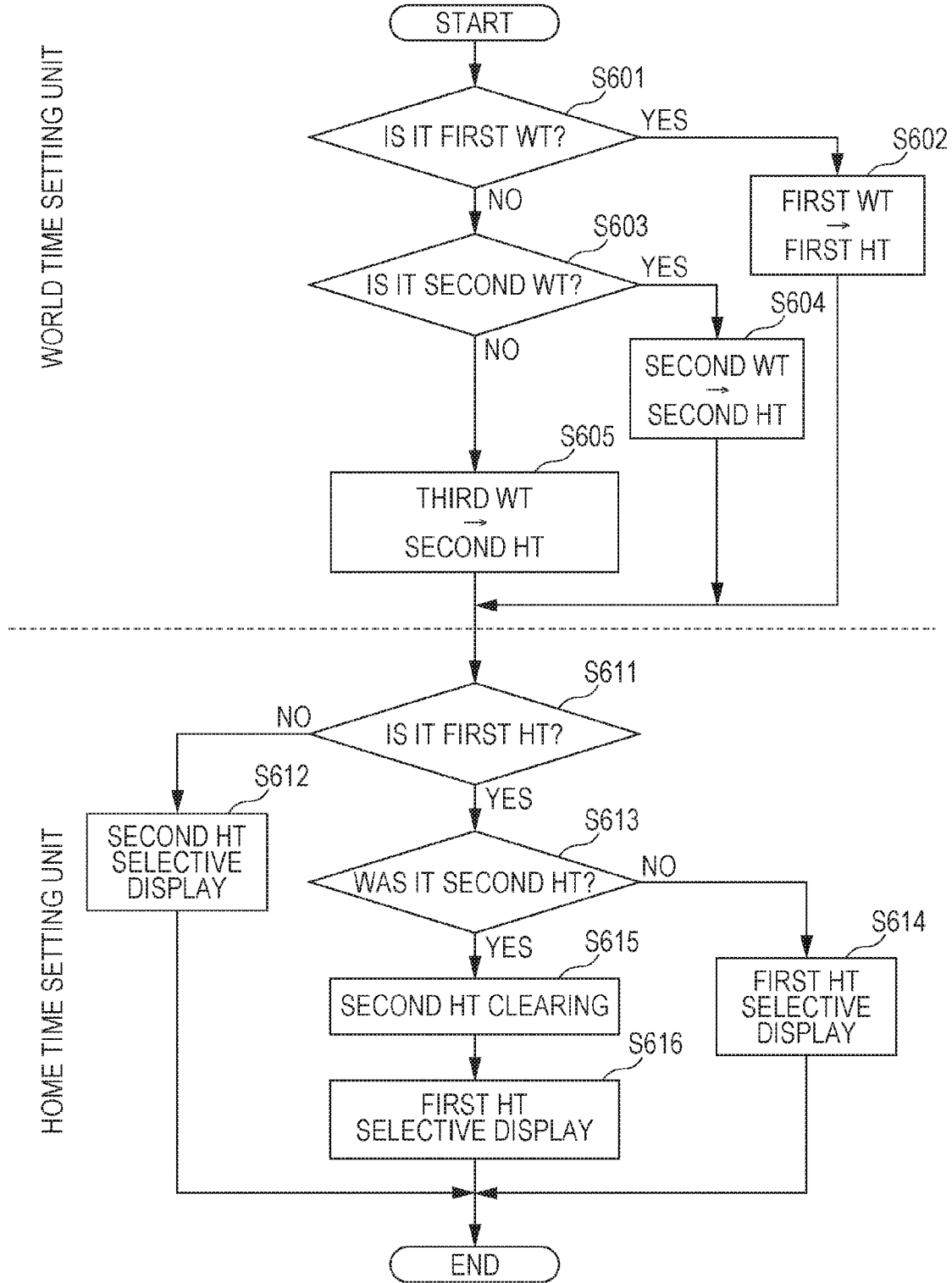

FIG. 15



ELECTRONIC TIMEPIECE

BACKGROUND OF THE INVENTION

The present invention relates to an electronic timepiece. 5

In recent years, electronic timepieces have developed to have multiple functions. For example, it is known that some electronic timepieces have a world time function that can display the times of various cities in the world. A world time function of an electronic timepiece is a function of measuring the time in a predetermined time zone (Japan, for example) where standard electronic waves can be received as the home time, calculating the time of a selected city from the time difference information about the selected city stored in a storage unit and the measured home time when the selected city is selected from among the various cities in the world through a user operation, and displaying and outputting the calculated time of the selected city, for example.

JP 2009-118403 A, for example, discloses an electronic timepiece that is connected to an external device such as a smartphone through short-range wireless communication such as Bluetooth (a registered trade name), and corrects time in accordance with time information received from the external device.

Also, there is a known electronic timepiece that has a function of adding a city (called an additional city) other than the cities preset from an external device.

Meanwhile, some electronic timepieces having a world time function can perform switching between a home time and a world time. When the home time or the world time is changed from an additional city to a preset city in such an electronic timepiece, the additional city remains in a storage area, resulting in unnecessary memory.

The home time city switching and the world time city switching are performed by a user looking at a small display window formed on the clock face of the electronic timepiece. Therefore, if the number of additional cities becomes larger, the switching process becomes much more troublesome.

Further, if city switching from the home time to the world time is performed in a case where the time of an additional city is set as the home time, for example, the city whose time was added as the home time is changed to the city whose time is set as the world time. Here, "city switching" means switching the cities displayed on the main time display unit **11** and the sub time display unit **12**.

From a viewpoint of a user, the city whose time was added as the home time is set as the world time, and therefore, it is not clear what has happened to the time of the city added as the home time. 50

SUMMARY OF THE INVENTION

To achieve the above object, the present invention provides an electronic timepiece that displays time based on city data related to the time of a city, 55

the electronic timepiece including:

a storage device including: a first storage area storing additional city data among the city data, the additional city data being related to the time of an additional city transmitted from an external device; and a second storage area storing the city data other than the additional city data stored in the first storage area, the second storage area being a storage area other than the first storage area; and 60

a processor that clears the additional city data stored in the first storage area when selected data is switched from the 65

additional city data stored in the first storage area to the city data stored in the second storage area.

BRIEF DESCRIPTION OF THE DRAWINGS

FIG. 1 is a functional block diagram showing the structure of an electronic timepiece according to an embodiment of the present invention;

FIG. 2 is a diagram showing an example configuration of an electronic timepiece system according to the embodiment; 10

FIG. 3 is a diagram showing an example of city setting data according to the embodiment;

FIG. 4 is a flowchart showing the procedures in a city change process in the home time; 15

FIG. 5 is a flowchart showing the procedures in a city change process in the world time;

FIGS. 6A and 6B are diagrams showing an example of data in a case where selective display is changed from a second home time to a first home time;

FIGS. 7A and 7B are diagrams showing an example of data in a case where selective display is changed from a third world time to a first world time;

FIGS. 8A and 8B are diagrams showing an example of data in a case where selective display is changed from the third world time to a second world time;

FIG. 9 shows the process to be performed when the city selectively displayed as the home time is selectively displayed as the world time in a city switching process; 30

FIG. 10 shows the process to be performed when the city selectively displayed as the world time is selectively displayed as the home time in a city switching process;

FIGS. 11A and 11B are diagrams showing an example of data in a process of switching between the first home time and the third world time; 35

FIGS. 12A and 12B are diagrams showing an example of data in a process of switching between the second home time and the first world time; 40

FIGS. 13A and 13B are diagrams showing display examples of city names according to the embodiment;

FIG. 14 shows the process to be performed when the city selectively displayed as the home time is selectively displayed as the world time in a city switching process; and

FIG. 15 shows the process to be performed when the city selectively displayed as the world time is selectively displayed as the home time in a city switching process. 45

DETAILED DESCRIPTION

The following is a detailed description of modes for carrying out the present invention (the modes will be hereinafter referred to as "embodiments"), with reference to the accompanying drawings.

<<Structure of an Electronic Timepiece>>

FIG. 1 is a functional block diagram showing the structure of an electronic timepiece according to this embodiment.

An electronic timepiece **1** includes a RAM (Random Access Memory) **101**, a ROM (Read Only Memory) **102**, a CPU (Central Processing Unit) **103**, a display device **105**, and an input device **104**.

A program (not shown) stored in the ROM **102** is loaded into the RAM **101** that provides the CPU **103** with a work memory space, and is executed by the CPU **103**, to embody a processing unit **120**, and a home time setting unit **121** and a world time setting unit **122** that constitute the processing unit **120**. 65

The home time setting unit **121** performs a process related to home time setting. Here, the “home time” is the time displayed on a main time display unit **11** (FIG. 2) of the electronic timepiece **1**.

The world time setting unit **122** performs a process related to world time setting. Here, the “world time” is the time of a different city from the city of the home time, and is set by a user operation or the like.

The processing unit **120**, and the home time setting unit **121** and the world time setting unit **122**, which constitute the processing unit **120**, may be included in the CPU **103**, or each may have an independent CPU or RAM to perform respective operations.

Further, city setting data **131** is stored (registered) in the RAM **101**. The city setting data **131** is data about the cities whose times are set as the home time and the world time. The city setting data **131** will be described later.

Preset city data **132** is stored in the ROM **102** that also stores the control program to be executed by the CPU **103** and control data. The preset city data **132** is data stored beforehand (at the time of shipment from the factory, for example) in the ROM **102**, and is about the cities whose times can be selected as the home time and the world time. As will be described later, a user can set the times of cities stored in the preset city data **132** as the home time and the world time, and can also set an additional city transmitted from an external device **2** (FIG. 2).

In this embodiment, a table or the like that holds temperature correction values for a crystal unit **109** is stored in the ROM **102**. However, this table is not shown in the drawings, and is not described in detail herein. Also, the table may be stored in a different memory (such as an EEPROM) from the ROM **102**.

The display device **105** is a liquid crystal panel placed on the clock face, and displays the names of the cities that are set as the home time and the world time.

Information about home time setting and world time setting is input to the input device **104**, and the processing unit **120** performs home time setting and world time setting in accordance with the information input to the input device **104**.

The electronic timepiece **1** also includes the crystal unit **109**, and an oscillator circuit **108** and a divider circuit **107** that generate a clock for measuring the current time. The electronic timepiece **1** further includes a timer circuit **106** that performs timing in accordance with a signal from the oscillator circuit **108** and the divider circuit **107**.

The electronic timepiece **1** further includes an antenna **112** and a receiver circuit **111**.

The antenna **112** receives a GPS (Global Positioning System) signal, and receives data transmitted from the external device **2**. The receiver circuit **111** is a filter, a detector circuit, or the like.

Here, a time counter that measures time and date is provided in the timer circuit **106**, and the value of the time counter is incremented by the clock from the divider circuit **107**, so that the current time is measured. The GPS signal received by the receiver circuit **111** contains time information. If the value of the time information does not match the value of the time counter in the timer circuit **106**, the counter value (the current time) is corrected. In this manner, accurate time display can be realized.

<<Configuration of an Electronic Timepiece System>>

FIG. 2 is a diagram showing an example configuration of an electronic timepiece system according to this embodiment.

An electronic timepiece system **10** includes the electronic timepiece **1** and the external device **2**. Here, the external device **2** is a smartphone, a portable telephone, a PC (Personal Computer), or the like.

The electronic timepiece **1** and the external device **2** are connected by short-range wireless communication with Bluetooth (a registered trade name) or the like. Through this short-range wireless communication, city data other than the preset city data **132** (FIG. 1) is additionally supplied to the electronic timepiece **1** from the external device **2**. The added city is called the “additional city”, and the data about the added city is called the “additional city data”.

The electronic timepiece **1** includes a main time display unit **11** that displays the home time, and a sub time display unit **12** that displays a world time. The electronic timepiece **1** has the display device **105** set on the clock face. The electronic timepiece **1** further includes push buttons **13** as the input device **104** at outer peripheral portions.

<<City Setting Data>>

FIG. 3 is a diagram showing an example of city setting data according to this embodiment. In the description below, FIGS. 1 and 2 will also be referred to as necessary.

The city setting data **131** is formed with a home time storage area **201** and a world time storage area **301**. The home time storage area **201** includes a first home time storage area **202** (a second storage area) and a second home time storage area **203** (a first storage area and a third storage area). Further, the world time storage area **301** includes a first world time storage area **302** (a second storage area), and a second world time storage area **303** and a third world time storage area **304** (a first storage area and a third storage area).

The first home time storage area **202** stores city data that has been selected from the preset city data **132** and been set. The city data stored in the first home time storage area **202** is set by a user mainly when communication with the external device **2** is not established.

The second home time storage area **203** stores additional city data. Additional city data is stored into the second home time storage area **203** in one of the manners described below.

(A1) When the electronic timepiece **1** is connected to the external device **2**, the external device **2** senses the current position with a GPS or the like. The external device **2** then transmits additional city data about the current position to the electronic timepiece **1**. The home time setting unit **121** of the electronic timepiece **1** stores the received additional city data as the second home time storage area **203**, and causes the main time display unit **11** to display the time indicated by the additional city data stored in the second home time storage area **203**.

(A2) A user manually causes the external device **2** to transmit additional city data. After the transmission of the additional city data, the same processing as that in (A1) is performed.

The first world time storage area **302** stores city data that has been selected from the preset city data **132** and been set.

The second world time storage area **303** and the third world time storage area **304** store additional city data. Unlike the additional city data stored in the third world time storage area **304** described later, the additional city data stored in the second world time storage area **303** can be changed or updated, but is preferably not to be cleared. With this, world time setting options can be maintained. The home time is normally the current time at the current location of the user. City data that was added in the past is basically unnecessary. If past city data remains, confusion might be caused. On the other hand, the world time is normally not the

time at the current location of the user, and city data that was added in the past can remain without causing any problem.

In the initial state of the electronic timepiece 1, additional city data may be already stored in the second world time storage area 303. With this, the second world time storage area 303 is prevented from becoming “null”, and it can be made clear that city data other than the preset city data 132 is stored in the second world time storage area 303.

In the third world time storage area 304, the additional city data that was stored in the second home time storage area 203 prior to a city switching process is stored.

Here, “city switching” means switching the cities displayed on the main time display unit 11 and the sub time display unit 12.

Each set of city data preferably includes a city number, a city code, a time difference, a summer time rule, data related to automatic switching on/off of daylight saving and utilization of daylight-saving time, and the like, but is not limited to such data content.

<<City Change>>

Referring now to FIGS. 4 through 8, a city change is described. In the description below, FIGS. 1 through 3 will also be referred to as necessary.

A city change means changing cities in the home time or world time.

[Flowcharts]

(Home Time Change Process)

FIG. 4 is a flowchart showing the procedures in a city change process in the home time.

In each of the flowcharts in FIGS. 4, 5, 9, 10, 14, and 15, each home time is referred to as “HT”, and each world time is referred to as “WT”.

When the electronic timepiece 1 senses a connection to an external device, or a user inputs a home time change instruction through the input device 104, the process shown in FIG. 4 is started. Here, “a user inputs a home time change instruction through the input device 104” means that a user inputs a home time change instruction by operating one or more of the push buttons 13.

First, the home time setting unit 121 determines whether the selective display on the main time display unit 11 indicates a first home time (first HT) (S101). Here, the “selective display” is the data displayed as a time on the main time display unit 11 or the sub time display unit 12 among the data about the cities set in the city setting data 131. For example, in a case where the time of “city C”, which is a second home time, is displayed on the main time display unit 11, it is described as “the second home time is selectively displayed as the home time”. Likewise, in a case where the time of “city C”, which is a third world time, is displayed on the sub time display unit 12, it is described as “the third world time is selectively displayed as the world time”.

If the result of step S101 indicates that the selective display on the main time display unit 11 indicates the first home time (Yes in S101), the home time setting unit 121 determines whether the selective display on the main time display unit 11 is to be changed to the second home time (second HT) (S111).

If the result of step S111 indicates that the selective display on the main time display unit 11 is to be changed to the second home time (Yes in S111), the home time setting unit 121 additionally stores additional city data into the second home time storage area 203 (S112). The additional city data is additionally stored, as the additional city data is transmitted from the external device 2 to the electronic timepiece 1. It should be noted that the result of step S111

becomes “Yes” when the electronic timepiece 1 senses a connection to the external device 2, for example.

The home time setting unit 121 then selectively displays the additional city data additionally stored into the second home time storage area 203 (second HT selective display: S113). That is, the time displayed on the main time display unit 11 is changed to the time of the additional city indicated by the additional city data stored in the second home time storage area 203.

At this point, the home time setting unit 121 may put the first home time storage area 202 into an “undetermined” or “null” state.

As the first home time storage area 202 that is not selectively displayed is put into an “undetermined” state, memory can be saved.

If the result of step S111 indicates that the selective display on the main time display unit 11 is not to be changed to the second home time (No in S111), the home time setting unit 121 performs a first home time setting process (S114).

The first home time setting process includes the processes described below.

(B1) The home time setting unit 121 updates the city data in the first home time storage area 202. After that, the home time setting unit 121 selectively displays, on the main time display unit 11, the time of the city indicated by the city data stored in the first home time storage area 202. If the first home time storage area 202 is “undetermined” at this point, the user selects the city of the first home time through the input device 104 (by operating the push buttons 13).

(B2) The home time setting unit 121 ends the city change process while maintaining the current city data in the first home time storage area 202. In this case, the time selectively displayed on the main time display unit 11 does not change.

If the result of step S101 indicates that the selective display on the main time display unit 11 is not the first home time (No in S101), or if the selective display on the main time display unit 11 indicates the second home time, the home time setting unit 121 determines whether the selective display on the main time display unit 11 is to be changed to the first home time (S121).

If the result of step S121 indicates that the selective display on the main time display unit 11 is to be changed to the first home time (Yes in S121), the home time setting unit 121 selectively displays the city data stored in the first home time storage area 202 (first HT selective display: S122). That is, the time displayed on the main time display unit 11 is changed to the time of the city indicated by the city data stored in the first home time storage area 202. If the city data in the first home time storage area 202 is “undetermined” at the point of step S122, the home time setting unit 121 selects the city of the first home time based on the current location or the like.

The home time setting unit 121 then clears the additional city data stored in the second home time storage area 203 (second HT clearing: S123). It should be noted that “clearing” means freeing the corresponding memory area in the RAM 101 (FIG. 1).

In this manner, generation of an unnecessary memory area can be prevented. Also, as the selection of world times can be narrowed, user friendliness can be increased.

If the result of step S121 indicates that the selective display on the main time display unit 11 is not to be changed to the first home time (No in S121), the home time setting unit 121 performs a second home time setting process (S124).

The second home time setting process includes the processes described below.

(C1) The home time setting unit **121** updates the additional city data in the second home time storage area **203**. After that, the home time setting unit **121** selectively displays, on the main time display unit **11**, the time of the additional city indicated by the additional city data stored in the second home time storage area **203**. If the second home time storage area **203** is “null” at this point, the additional city data is transmitted from the external device **2** to the electronic timepiece **1**.

(C2) The home time setting unit **121** ends the city change process while maintaining the current additional city data in the second home time storage area **203**. In this case, the time selectively displayed on the main time display unit **11** does not change.

(World Time Change Process)

FIG. **5** is a flowchart showing the procedures in a city change process in the world time.

When the electronic timepiece **1** senses a connection to an external device, or a user inputs a world time change instruction through the input device **104**, the process shown in FIG. **5** is started. Here, “a user inputs a world time change instruction through the input device **104**” means that a user inputs a world time change instruction by operating the push buttons **13**.

First, the world time setting unit **122** determines whether the selective display on the sub time display unit **12** indicates a first world time (first WT) or a second world time (second WT) (S201).

If the result of step S201 indicates that the selective display on the sub time display unit **12** indicates the first world time or the second world time (Yes in S201), the world time setting unit **122** performs a first/second world time setting process (S211).

The first/second world time setting process includes the processes described below.

(D1) The world time setting unit **122** updates the city data in the first world time storage area **302**. After that, the world time setting unit **122** selectively displays, on the sub time display unit **12**, the time of the city indicated by the city data stored in the first world time storage area **302**. If the city data in the first world time storage area **302** is “undetermined” at this point, the world time setting unit **122** selects the city of the first world time based on the current location or the like.

(D2) The world time setting unit **122** additionally stores additional city data into the second world time storage area **303**. After that, the world time setting unit **122** selectively displays, on the sub time display unit **12**, the time of the additional city indicated by the additional city data stored in the second world time storage area **303**. If the second world time storage area **303** is “null” at this point, the additional city data is transmitted from the external device **2** to the electronic timepiece **1**.

(D3) The world time setting unit **122** ends the city change process while maintaining the current city data in the first world time storage area **302**.

(D4) The world time setting unit **122** ends the city change process while maintaining the current additional city data in the second world time storage area **303**.

(D5) The world time setting unit **122** changes the selective display on the sub time display unit **12** from the first world time to the second world time. That is, the world time setting unit **122** changes the time displayed on the sub time display unit **12** from the time of the city indicated by the city data stored in the first world time storage area **302** to the time of the additional city indicated by the additional city data stored in the second world time storage area **303**. At this point, the world time setting unit **122** may put the first world

time storage area **302** into an “undetermined” state. As the first world time storage area **302** that is not selectively displayed is put into an “undetermined” state, memory can be saved. If the second world time storage area **303** is “null” at this point, the additional city data is transmitted from the external device **2** to the electronic timepiece **1**.

(D6) The world time setting unit **122** additionally stores the transmitted additional city data into the second world time storage area **303**, and changes the selective display on the sub time display unit **12** from the first world time to the second world time. That is, the world time setting unit **122** changes the time displayed on the sub time display unit **12** from the time of the city indicated by the city data stored in the first world time storage area **302** to the time of the additional city indicated by the additional city data stored in the second world time storage area **303**. At this point, the world time setting unit **122** may put the first world time storage area **302** into an “undetermined” state. As the first world time storage area **302** that is not selectively displayed is put into an “undetermined” state, memory can be saved. If the second world time storage area **303** is “null” at this point, the external device **2** transmits the additional city data to the electronic timepiece **1**.

(D7) The world time setting unit **122** changes the selective display on the sub time display unit **12** from the second world time to the first world time. That is, the world time setting unit **122** changes the time displayed on the sub time display unit **12** from the time of the additional city indicated by the additional city data stored in the second world time storage area **303** to the time of the city indicated by the city data stored in the first world time storage area **302**. If the city data in the first world time storage area **302** is “undetermined” at this point, the world time setting unit **122** selects the city of the first world time based on the current location or the like.

If the result of step S201 indicates that the selective display on the sub time display unit **12** indicates neither the first world time nor the second world time (No in S201), the selective display on the sub time display unit **12** indicates the third world time. The world time setting unit **122** then determines whether the selective display on the sub time display unit **12** is to be changed to the first world time or the second world time (S221).

If the result of step S221 indicates that the selective display on the sub time display unit **12** is to be changed to the first world time or the second world time (Yes in S221), the world time setting unit **122** selectively displays the city data stored in the first world time storage area **302** or the additional city data stored in the second world time storage area **303** (first WT or second WT selective display: S222). That is, the time displayed on the sub time display unit **12** is changed to the time of the city indicated by the city data stored in the first world time storage area **302** or to the time of the additional city indicated by the additional city data stored in the second world time storage area **303**. In a case where the first world time is selectively displayed in step S222, if the city data in the first world time storage area **302** is undetermined, the user selects the city of the first world time through the input device **104** (by operating the push buttons **13**). Likewise, in a case where the second world time is selectively displayed in step S222, if the second world time storage area **303** is “null”, the external device **2** transmits additional city data to the electronic timepiece **1**. The world time setting unit **122** then additionally stores the transmitted additional city data into the second world time storage area **303**.

The world time setting unit **122** then clears the additional city data stored in the third world time storage area **304** (third WT clearing: **S223**).

In this manner, generation of an unnecessary memory area can be prevented. Also, as the selection of world times can be narrowed, user friendliness can be increased.

If the result of step **S221** indicates that the selective display on the sub time display unit **12** is not to be changed to the first world time or the second world time (No in **S221**), a third world time setting process is performed (**S224**).

The third world time setting process includes the processes described below.

(E1) The world time setting unit **122** updates the additional city data in the third world time storage area **304**. After that, the world time setting unit **122** selectively displays, on the sub time display unit **12**, the time of the additional city indicated by the additional city data stored in the third world time storage area **304**. If the third world time storage area **304** is “null” at this point, the additional city data is transmitted from the external device **2** to the electronic timepiece **1**.

(E2) The world time setting unit **122** ends the city change process while maintaining the current additional city data in the third world time storage area **304**. In this case, the time selectively displayed on the sub time display unit **12** does not change.

[Specific Examples of City Data Changes]

Referring now to FIGS. **6A** through **8B**, specific examples of data in city change processes are described. The description below concerns example cases where the additional city data in the second home time storage area **203** and the third world time storage area **304**, which is the feature of this embodiment, is cleared, and other examples will not be described.

In FIGS. **6A** through **8B**, the data indicated by shaded portions is data that is selectively displayed.

The unfilled data indicates that the data is “null”. Also, “(undetermined)” means “not selected”, or “null”. Here, an “undetermined” state is a state where any preset city data **132** is not selected for the first home time or the first world time. An “undetermined” state is the same as a “null” state. In the first home time storage area **202** or the first world time storage area **302**, the term “undetermined” is used to emphasize that the already stored preset city data **132** is to be input thereto. On the other hand, the additional city data to be stored into the second home time storage area **203**, the second world time storage area **303**, and the third world time storage area **304** are not necessarily stored in the electronic timepiece **1**, and therefore, the term “null” is used therein.

FIGS. **6A** and **6B** are diagrams showing an example of data in a case where selective display is changed from the second home time to the first home time.

Prior to the switching, the city setting state is as shown in FIG. **6A**. Specifically, the “city C” stored in the second home time storage area **203** is selectively displayed, and the first home time storage area **202** is in an “undetermined” state. It should be noted that the “◆” displayed beside “city C” means that this city data is additional city data.

FIG. **6A** shows the home time storage area **201** in a situation where the result of step **S101** is “No” and the result of step **S121** is “Yes” in FIG. **4**.

If “city A” is selectively displayed as the first home time in this situation, the data changes as shown in FIG. **6B**.

FIG. **6B** shows the home time storage area **201** in a situation where the result of step **S101** is “No”, the result of step **S121** is “Yes”, and steps **S122** and **S123** have been completed in FIG. **4**.

In FIG. **6B**, the city data of the “city A” is stored into the first home time storage area **202**, and the first home time is selectively displayed. The additional city data of the “city C” in the second home time storage area **203** is then cleared. Here, “clearing” means freeing the corresponding memory area in the RAM **101** (FIG. **1**).

FIGS. **7A** and **7B** are diagrams showing an example of data in a case where selective display is changed from the third world time to the first world time.

Prior to the switching, the city setting state is as shown in FIG. **7A**. Specifically, the “city C” stored in the third world time storage area **304** is selectively displayed, and the first world time storage area **302** is in an “undetermined” state. In the second world time storage area **303**, “city B” is stored as additional city data.

FIG. **7A** shows the world time storage area **301** in a situation where the result of step **S201** is “No” and the result of step **S221** is “Yes” (a change to the first world time) in FIG. **5**.

If “city A” is selectively displayed as the first world time in this situation, the data changes as shown in FIG. **7B**.

FIG. **7B** shows the world time storage area **301** in a situation where the result of step **S201** is “No”, the result of step **S221** is “Yes” (a change to the first world time), and steps **S222** and **S223** have been completed in FIG. **5**.

In FIG. **7B**, the city data of the “city A” is stored into the first world time storage area **302**, and the first world time is selectively displayed. The additional city data of the “city C” in the third world time storage area **304** is then cleared.

FIGS. **8A** and **8B** are diagrams showing an example of data in a case where selective display is changed from the third world time to the second world time.

Prior to the switching, the city setting state is as shown in FIG. **8A**. Specifically, the “city C” stored in the third world time storage area **304** is selectively displayed, and the first world time storage area **302** is in an “undetermined” state. In the second world time storage area **303**, “city B” is stored as additional city data.

FIG. **8A** shows the world time storage area **301** in a situation where the result of step **S201** is “No” and the result of step **S221** is “Yes” (a change to the second world time) in FIG. **5**.

FIG. **8B** shows the world time storage area **301** in a situation where the result of step **S201** is “No”, the result of step **S221** is “Yes” (a change to the second world time), and steps **S222** and **S223** have been completed in FIG. **5**.

If “city B” is selectively displayed as the second world time in FIG. **8A**, the data changes as shown in FIG. **8B**.

That is, the “city B” stored in the second world time storage area **303** is selectively displayed, and the additional city data of the “city C” in the third world time storage area **304** is cleared.

<<City Switching>>

[Flowcharts]

Referring now to FIGS. **9** and **10**, the procedures in city switching processes according to this embodiment are described. Although the city switching processes described below are divided into the process shown in FIG. **9** and the process shown in FIG. **10** in this embodiment, the process shown in FIG. **9** and the process shown in FIG. **10** are processes to be performed in parallel, with the use of a temporary file or the like. In the description below, FIGS. **1** and **3** will also be referred to as necessary.

(Switching from Home Time to World Time)

FIG. **9** shows the process to be performed when the city selectively displayed as the home time is selectively displayed as the world time in a city switching process.

11

When a user inputs a city switching instruction through the input device **104**, the process shown in FIG. **9** is started. Here, “a user inputs a city switching instruction through the input device **104**” means that a user inputs a city switching instruction by operating the push buttons **13**.

First, the home time setting unit **121** determines whether the home time currently displayed as selective display on the main time display unit **11** is the first home time (first HT) (S**301**).

If the result of step S**301** indicates that the current selective display on the main time display unit **11** indicates the first home time (Yes in S**301**), the home time setting unit **121** stores the city data stored in the first home time storage area **202** (first HT) into the first world time storage area **302** (first WT) (first HT to first WT: S**311**). At this point, the home time setting unit **121** may put the first home time storage area **202** into an “undetermined” state.

As the first home time storage area **202** that is not selectively displayed is put into an “undetermined” state, memory can be saved. The “undetermined” state will be described later.

The world time setting unit **122** then selectively displays the city data stored in the first world time storage area **302** as the world time (first WT selective display: S**312**). That is, the time displayed on the sub time display unit **12** is changed to the time of the city indicated by the city data stored in the first world time storage area **302**.

If the result of step S**301** indicates that the selective display on the main time display unit **11** does not indicate the first home time (No in S**301**), the home time setting unit **121** stores the additional city data stored in the second home time storage area **203** (second HT) into the third world time storage area **304** (third WT) (second HT to third WT: S**321**). The home time setting unit **121** then clears the additional city data stored in the second home time storage area **203** (second HT clearing: S**322**).

In this manner, generation of an unnecessary memory area can be prevented. Also, as the selection of world times can be narrowed, user friendliness can be increased.

The world time setting unit **122** then selectively displays the additional city data stored in the third world time storage area **304** as the world time (third WT selective display: S**323**). That is, the time displayed on the sub time display unit **12** is changed to the time of the additional city indicated by the additional city data stored in the third world time storage area **304**.

(Switching from World Time to Home Time)

FIG. **10** shows the process to be performed when the city selectively displayed as the world time is selectively displayed as the home time in a city switching process.

When a user inputs a city switching instruction through the input device **104**, the process shown in FIG. **10** is started. The “a user inputs a city switching instruction through the input device **104**” means that a user inputs a city switching instruction by operating the push buttons **13**.

First, the world time setting unit **122** determines whether the current selective display on the sub time display unit **12** indicates the first world time (first WT) (S**401**).

If the result of step S**401** indicates that the current selective display on the sub time display unit **12** indicates the first world time (Yes in S**401**), the world time setting unit **122** stores the city data stored in the first world time storage area **302** (first WT) into the first home time storage area **202** (first HT) (first WT to first HT: S**411**). At this point, the world time setting unit **122** may put the first world time storage area **302** into an “undetermined” state.

12

As the first world time storage area **302** that is not selectively displayed is put into an “undetermined” state, memory can be saved.

The home time setting unit **121** then selectively displays the city data stored in the first home time storage area **202** as the home time (first HT selective display: S**412**). That is, the time displayed on the main time display unit **11** is changed to the time of the city indicated by the city data stored in the first home time storage area **202**.

If the result of step S**401** indicates that the current selective display on the sub time display unit **12** does not indicate the first world time (No in S**401**), the world time setting unit **122** determines whether the current selective display on the sub time display unit **12** indicates the second world time (second WT) (S**421**).

If the result of step S**421** indicates that the current selective display on the sub time display unit **12** indicates the second world time (Yes in S**421**), the world time setting unit **122** stores the additional city data stored in the second world time storage area **303** (second WT) into the second home time storage area **203** (second HT) (second WT to second HT: S**422**).

The home time setting unit **121** then selectively displays the additional city data stored in the second home time storage area **203** as the home time (second HT selective display: S**423**). That is, the time displayed on the main time display unit **11** is changed to the time of the additional city indicated by the additional city data stored in the second home time storage area **203**.

If the result of step S**421** indicates that the current selective display on the sub time display unit **12** does not indicate the second world time (No in S**421**), the world time currently displayed as selective display is the third world time. Therefore, the world time setting unit **122** stores the additional city data stored in the third world time storage area **304** (third WT) into the second home time storage area **203** (second HT) (third WT to second HT: S**431**).

The world time setting unit **122** then clears the additional city data stored in the third world time storage area **304** (third WT clearing: S**432**).

In this manner, generation of an unnecessary memory area can be prevented. Also, as the selection of world times can be narrowed, user friendliness can be increased.

The home time setting unit **121** then selectively displays the additional city data stored in the second home time storage area **203** as the home time (second HT selective display: S**423**). That is, the time displayed on the main time display unit **11** is changed to the time of the additional city indicated by the additional city data stored in the second home time storage area **203**.

[Specific Examples of Data in City Switching]

FIGS. **11A** through **12B** are diagrams showing specific examples of data in city switching processes. The description below concerns example cases where the additional city data in the second home time storage area **203** and the third world time storage area **304**, which is the feature of this embodiment, is cleared, and other examples will not be described.

In FIGS. **11A** through **12B**, the data indicated by shaded portions is data that is selectively displayed. Also, in FIGS. **11A** through **12B**, the reference numerals are the same as those used in FIG. **3**, and therefore, explanation of them is not repeated herein.

FIGS. **11A** and **11B** are diagrams showing an example of data in a process of switching between the first home time and the third world time.

Prior to the switching, the city setting state is as shown in FIG. 11A.

FIG. 11A shows the home time storage area 201 and the world time storage area 301 in a situation where the result of step S401 is "No" and the result of step S421 is "No" in FIG. 10.

Here, the data indicated by shaded portions is data that is selectively displayed. That is, on the electronic timepiece 1, the time displayed as the home time is the time of "city A", and the time displayed as the world time is the time of "city C". Also, "◆" that is displayed beside each city name is the symbol indicating an additional city.

The unfilled data indicates that the data is "null". Also, "(undetermined)" means "not selected".

When switching between the home time and the world time is performed in this situation, the city setting data 131 changes as shown in FIG. 11B.

FIG. 11B shows the home time storage area 201 and the world time storage area 301 in a situation where the result of step S401 is "No", the result of step S421 is "No", and steps S431, S432, and S423 have been completed in FIG. 10.

That is, the city data of "city A" that is stored in the first home time storage area 202 in FIG. 11A is stored into the first world time storage area 302. This is because "city A" is a preset city.

Also, "city C" that is stored in the third world time storage area 304 in FIG. 11A is an additional city, and therefore, the additional city data of "city C" is stored into the second home time storage area 203.

The additional city data stored in the third world time storage area 304 prior to the city switching (FIG. 11A) is then cleared.

FIGS. 12A and 12B are diagrams showing an example of data in a process of switching between the second home time and the first world time.

Prior to the switching, the city setting state is as shown in FIG. 12A.

FIG. 12A shows the home time storage area 201 and the world time storage area 301 in a situation where the result of step S301 is "No" in FIG. 9.

On the electronic timepiece 1, the time displayed as the home time is the time of "city D", and the time displayed as the world time is the time of "city A".

When switching between the home time and the world time is performed in this situation, the city setting data 131 changes as shown in FIG. 12B.

FIG. 12B shows the home time storage area 201 and the world time storage area 301 in a situation where the result of step S301 is "No", and steps S321, S322, and S323 have been completed in FIG. 9.

That is, the additional city data of "city D" that is stored in the second home time storage area 203 in FIG. 12A is stored into the third world time storage area 304.

Also, "city A" that is stored in the first world time storage area 302 is a preset city, and therefore, the city data of "city A" is stored into the first home time storage area 202.

The additional city data stored in the second home time storage area 203 prior to the city switching (FIG. 12A) is then cleared.

[Display Examples]

FIGS. 13A and 13B are diagrams showing display examples of city names according to this embodiment.

As shown in FIGS. 13A and 13B, either "H" or "W" is displayed on the display device 105. "H" shown in FIG. 13A means the home time, and the city currently displayed in the display window is the city that is set as the city of the home time.

Likewise, "W" shown in FIG. 13B means the world time, and the city currently displayed in the display window is the city that is set as the city of the world time.

When "◆" is displayed beside the city name as shown in FIG. 13B, the city is an additional city.

[Other Embodiments]

Referring now to FIGS. 14 and 15, city switching processes according to another embodiment are described. In the description below, FIGS. 1 and 3 will also be referred to as necessary. Although the processes in FIGS. 14 and 15 are shown in separate flowcharts, but these processes are preferably performed in parallel.

(Switching from Home Time to World Time)

FIG. 14 shows the process to be performed when the city selectively displayed as the home time is selectively displayed as the world time in a city switching process.

When a user inputs a city switching instruction through the input device 104, the process shown in FIG. 14 is started. The "a user inputs a city switching instruction through the input device 104" means that a user inputs a city switching instruction by operating the push buttons 13.

First, the home time setting unit 121 determines whether the current selective display on the main time display unit 11 indicates the first home time (S501).

If the result of step S501 indicates that the current selective display on the main time display unit 11 indicates the first home time (Yes in S501), the home time setting unit 121 stores the city data stored in the first home time storage area 202 into the first world time storage area 302 (first HT to first WT: S502). After that, the processing unit 120 moves on to step S511.

If the result of step S501 indicates that the current selective display on the main time display unit 11 does not indicate the first home time (No in S501), the home time currently displayed as the selective display is the second home time. Therefore, the home time setting unit 121 stores the additional city data stored in the second home time storage area 203 into the third world time storage area 304 (second HT to third WT: S503). After that, the processing unit 120 moves on to step S511.

The world time setting unit 122 then determines whether the time of the city designated to be selectively displayed on the sub time display unit 12 through the input device 104 is set as the first world time or the second world time (S511). That is, the world time setting unit 122 determines whether the city data of the city designated to be selectively displayed on the sub time display unit 12 is stored in the first world time storage area 302 or the second world time storage area 303.

If the result of S511 indicates that time of the designated city is not set as the first world time or the second world time (No in S511), the time of the city designated to be selectively displayed is the time of the city set as the third world time. Therefore, the world time setting unit 122 selectively displays the time of the city set as the third world time (third WT selective display: S512). That is, the time displayed on the sub time display unit 12 is changed to the time of the additional city indicated by the additional city data stored in the third world time storage area 304.

If the result of step S511 indicates that the time of the designated city is set as the first world time or the second world time (Yes in S511), the world time setting unit 122 determines whether the world time displayed before the city switching instruction was issued is the third world time (S513). That is, the world time setting unit 122 determines

15

whether the selective display on the sub time display unit **12** before the city switching instruction was issued indicated the third world time.

If the result of step **S513** indicates that the world time displayed before the city switching instruction was issued is not the third world time (No in **S513**), the world time setting unit **122** selectively displays the world time that has been set in step **S502** or **S503** (**S515**). That is, in a case where step **S502** has been carried out, the time displayed on the sub time display unit **12** is changed to the time of the city indicated by the city data stored in the first world time storage area **302**. In a case where step **S503** has been carried out, the time displayed on the sub time display unit **12** is changed to the time of the additional city indicated by the additional city data stored in the third world time storage area **304**.

If the result of step **S513** indicates that the world time displayed before the city switching instruction was issued is the third world time (Yes in **S513**), the world time setting unit **122** clears the third world time storage area **304** (third WT clearing: **S514**).

In this manner, generation of an unnecessary memory area can be prevented. Also, as the selection of world times can be narrowed, user friendliness can be increased.

The world time setting unit **122** then selectively displays the world time that has been set in step **S502** or **S503** (**S515**). That is, in a case where step **S502** has been carried out, the time displayed on the sub time display unit **12** is changed to the time of the city indicated by the city data stored in the first world time storage area **302**. In a case where step **S503** has been carried out, the time displayed on the sub time display unit **12** is changed to the time of the additional city indicated by the additional city data stored in the third world time storage area **304**.

(Switching from Home Time to World Time)

FIG. **15** shows the process to be performed when the city selectively displayed as the world time is selectively displayed as the home time in a city switching process.

When a user inputs a city switching instruction through the input device **104**, the process shown in FIG. **15** is started. The "a user inputs a city switching instruction through the input device **104**" means that a user inputs a city switching instruction by operating the push buttons **13**.

First, the world time setting unit **122** determines whether the current selective display on the sub time display unit **12** indicates the first world time (**S601**).

If the result of step **S601** indicates that the current selective display on the sub time display unit **12** indicates the first world time (Yes in **S601**), the world time setting unit **122** stores the city data currently stored in the first world time storage area **302** into the first home time storage area **202** (first WT to first HT: **S602**). After that, the processing unit **120** moves on to step **S611**.

If the result of step **S601** indicates that the current selective display on the sub time display unit **12** does not indicate the first world time (No in **S601**), the world time setting unit **122** determines whether the current selective display on the sub time display unit **12** indicates the second world time (**S603**).

If the result of step **S603** indicates that the current selective display on the sub time display unit **12** indicates the second world time (Yes in **S603**), the world time setting unit **122** stores the additional city data stored in the second world time storage area **303** into the second home time storage area **203** (second WT to second HT: **S604**). After that, the processing unit **120** moves on to step **S611**.

If the result of step **S603** indicates that the current selective display on the sub time display unit **12** does not

16

indicate the second world time (No in **S603**), the world time currently displayed as selective display is the third world time. Therefore, the world time setting unit **122** stores the additional city data stored in the third world time storage area **304** into the second home time storage area **203** (third WT to second HT: **S605**). After that, the processing unit **120** moves on to step **S611**.

The home time setting unit **121** then determines whether the time of the city designated to be selectively displayed as the home time on the main time display unit **11** through the input device **104** is set as the first home time (**S611**). That is, the home time setting unit **121** determines whether the city data of the city designated to be selectively displayed as the home time on the main time display unit **11** through the input device **104** is stored in the first home time storage area **202**. It should be noted that "through the input device **104**" means that "the user operating the push buttons **13**", for example.

If the result of step **S611** indicates that the time of the designated city is not set as the first home time (No in **S611**), the time of the city designated to be selectively displayed is the time that is set as the second home time. Therefore, the home time setting unit **121** selectively displays the time of the city set as the second home time (second HT selective display: **S612**). That is, the time displayed on the main time display unit **11** is changed to the time of the additional city indicated by the additional city data stored in the second home time storage area **203**.

If the result of step **S611** indicates that the time of the designated city is set as the first home time (Yes in **S611**), the home time setting unit **121** determines whether the home time selectively displayed before the city switching instruction was issued is the second time (**S613**). That is, the home time setting unit **121** determines whether the city data of the city designated to be selectively displayed as the home time on the main time display unit **11** through the input device **104** is stored in the second home time storage area **203**. It should be noted that "through the input device **104**" means that "the user operating the push buttons **13**", for example.

If the result of step **S613** indicates that the home time displayed before the city switching instruction was issued is not the second home time (No in **S613**), the home time setting unit **121** selectively displays the home time that is set as the first home time (first HT selective display: **S614**). That is, the time displayed on the main time display unit **11** is changed to the time of the city indicated by the city data stored in the first home time storage area **202**.

If the result of step **S613** indicates that the home time displayed before the city switching instruction was issued is the second home time (Yes in **S613**), the home time setting unit **121** clears the second home time storage area **203** (second HT clearing: **S615**).

In this manner, generation of unnecessary memory area can be prevented. Also, as the selection of home times can be narrowed, user friendliness can be increased.

The home time setting unit **121** then selectively displays the time of the city that is set as the first home time (first HT selective display: **S616**). That is, the time displayed on the main time display unit **11** is changed to the time of the city indicated by the city data stored in the first home time storage area **202**.

According to this embodiment, when selective display is switched from the second home time storage area **203** or the third world time storage area **304** to another storage area, the second home time storage area **203** or the third world time storage area **304**, whichever has been selectively displayed, is cleared. In this manner, generation of an unnecessary memory area can be eliminated. Also, as the selection of

17

home times can be narrowed, user friendliness at a time when the city is checked with the small display device **105** can be increased.

It should be noted that additional city data may not be transmitted through the external device **2**. Instead, additional city data may be transmitted from a server of a company or the like via a telephone line or the like.

Communication between the electronic timepiece **1** and the external device **2** may be established not necessarily with short-range wireless communication such as Bluetooth (a registered trade name), but with a cable connection such as a USB (Universal Serial Bus) or with a wireless LAN (Local Area Network).

The second world time storage area **303** may be eliminated.

On the contrary, two or more second world time storage areas **303** may be provided.

Further, in this embodiment, the city whose time is set as the second world time may be updated but is not to be cleared. However, the second world time may function like the second home time. That is, the second world time storage area **303** may store not only additional city data transmitted from the external device **2** but also the data of the additional city whose time is set as the second home time in a city switching process.

The electronic timepiece **1** may display only the home time. In such a case, only the process shown in FIG. **4** is performed.

When disconnected from the external device **2**, the processing unit **120** may immediately conduct selective display of the first home time as the home time and the first world time as the world time, and clear the second home time storage area **203** and the third world time storage area **304**. By doing so, the processing unit **120** can narrow down the selectable city data to the preset city data **132** when disconnected from the external device **2**.

The invention claimed is:

1. An electronic timepiece that displays time based on city data related to time of a city, the electronic timepiece comprising:

a storage device including: a first storage area storing additional city data among the city data, the additional city data being related to a time of an additional city transmitted from an external device; and a second storage area storing the city data other than the additional city data stored in the first storage area, the second storage area being a storage area other than the first storage area; and

a processor configured to clear the additional city data stored in the first storage area when selected data is switched from the additional city data stored in the first storage area to the city data stored in the second storage area.

2. The electronic timepiece according to claim **1**, wherein the additional city data stored in the first storage area is related to a home time, the home time being a time in a region where the electronic timepiece is located, the city data stored in the second storage area is related to the home time, and

the processor controls the additional city data and the city data related to the home time, and clears the additional city data stored in the first storage area when selected data is switched from the additional city data stored in the first storage area to the city data stored in the second storage area.

18

3. The electronic timepiece according to claim **1**, wherein the additional city data stored in the first storage area is related to a world time, the world time being a time outside a region where the electronic timepiece is located,

the city data stored in the second storage area is related to the world time, and

the processor controls the additional city data and the city data related to the world time, and clears the additional city data stored in the first storage area when selected data is switched from the additional city data stored in the first storage area to the city data stored in the second storage area.

4. The electronic timepiece according to claim **2**, wherein the additional city data stored in the first storage area is related to a world time, the world time being a time outside the region where the electronic timepiece is located,

the city data stored in the second storage area is related to the world time, and

the processor controls the additional city data and the city data related to the world time, and clears the additional city data stored in the first storage area when selected data is switched from the additional city data stored in the first storage area to the city data stored in the second storage area.

5. The electronic timepiece according to claim **1**, wherein a third storage area is formed in the storage device, additional city data related to a time of an additional city being stored into the third storage area at a world time, the additional city data being transmitted from the external device, and

the processor moves the additional city data stored in the first storage area at a home time indicating a time in a region where the electronic timepiece is located into the third storage area at the world time, and clears the additional city data stored in the first storage area.

6. The electronic timepiece according to claim **2**, wherein a third storage area is formed in the storage device, additional city data related to a time of an additional city being stored into the third storage area at a world time, the additional city data being transmitted from the external device, and

the processor moves the additional city data stored in the first storage area at the home time indicating the time in the region where the electronic timepiece is located into the third storage area at the world time, and clears the additional city data stored in the first storage area.

7. The electronic timepiece according to claim **3**, wherein a third storage area is formed in the storage device, additional city data related to a time of an additional city being stored into the third storage area at the world time, the additional city data being transmitted from the external device, and

the processor moves the additional city data stored in the first storage area at a home time indicating the time in the region where the electronic timepiece is located into the third storage area at the world time, and clears the additional city data stored in the first storage area.

8. The electronic timepiece according to claim **4**, wherein a third storage area is formed in the storage device, additional city data related to a time of an additional city being stored into the third storage area at the world time, the additional city data being transmitted from the external device, and

the processor moves the additional city data stored in the first storage area at the home time indicating the time

