



US009519820B2

(12) **United States Patent**  
**Sezille**

(10) **Patent No.:** **US 9,519,820 B2**

(45) **Date of Patent:** **\*Dec. 13, 2016**

(54) **METHODS AND SYSTEMS FOR AUTHENTICATING USERS**

(71) Applicant: **Daon Holdings Limited**, George Town (KY)

(72) Inventor: **Nicolas Jacques Jean Sezille**, Dublin (IE)

(73) Assignee: **DAON HOLDINGS LIMITED**, George Town (KY)

(\* ) Notice: Subject to any disclaimer, the term of this patent is extended or adjusted under 35 U.S.C. 154(b) by 171 days.

This patent is subject to a terminal disclaimer.

(21) Appl. No.: **13/887,395**

(22) Filed: **May 6, 2013**

(65) **Prior Publication Data**

US 2013/0243267 A1 Sep. 19, 2013

**Related U.S. Application Data**

(63) Continuation of application No. 13/010,443, filed on Jan. 20, 2011, now Pat. No. 8,457,370.

(51) **Int. Cl.**  
**G06K 9/00** (2006.01)  
**G06K 9/32** (2006.01)

(52) **U.S. Cl.**  
CPC ..... **G06K 9/00087** (2013.01); **G06K 9/00013** (2013.01); **G06K 9/3216** (2013.01)

(58) **Field of Classification Search**  
None  
See application file for complete search history.

(56) **References Cited**

U.S. PATENT DOCUMENTS

5,483,601 A 1/1996 Faulkner  
5,493,621 A 2/1996 Matsumura  
(Continued)

FOREIGN PATENT DOCUMENTS

EP 0 930 580 A2 7/1999  
EP 0 930 580 A3 7/1999  
(Continued)

OTHER PUBLICATIONS

Amit Jain et al.: "A Multiscale Representation Including Opponent Color Features for Texture Recognition," IEEE Trans. on Image Pro., vol. 7, No. 1, Jan. 1998, pp. 124-128.

(Continued)

*Primary Examiner* — Jayesh A Patel

(74) *Attorney, Agent, or Firm* — Kevin McDermott, Esq.

(57) **ABSTRACT**

A method of authenticating users is provided that includes capturing biometric authentication data of a user and processing the captured biometric data into an image. Moreover, the method includes determining a region of interest of the image and a gray scale image from the image, determining an optimum transformation parameter set within the region of interest, and aligning the gray scale image with an enrollment gray scale image generated during enrollment of the user using results of the optimum transformation parameter set determination. Furthermore, the method includes extracting biometric feature data from the gray scale image and verifying an identity of the user with extracted biometric feature data included in a region of agreement.

**6 Claims, 8 Drawing Sheets**

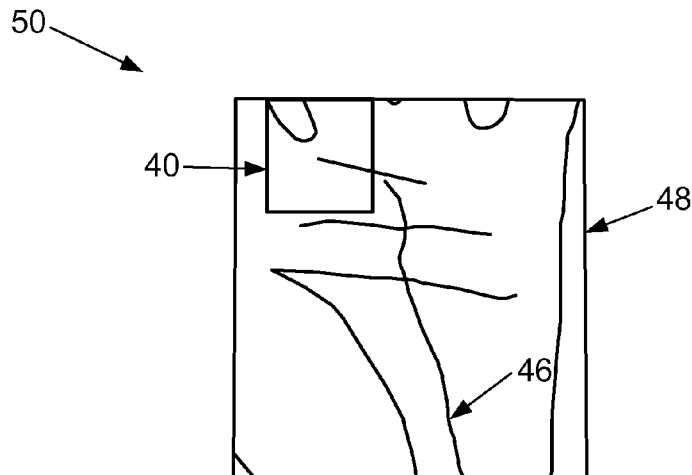

(56)

References Cited

U.S. PATENT DOCUMENTS

5,862,249 A 1/1999 Jang et al.  
 5,991,429 A 11/1999 Coffin et al.  
 6,128,398 A 10/2000 Kuperstein et al.  
 6,185,316 B1\* 2/2001 Buffam ..... 382/115  
 6,314,197 B1 11/2001 Jain et al.  
 6,487,306 B1 11/2002 Jain et al.  
 6,546,122 B1 4/2003 Russo  
 6,836,554 B1\* 12/2004 Bolle et al. .... 382/116  
 6,901,155 B2 5/2005 Xia et al.  
 6,952,489 B1 10/2005 Angelo et al.  
 7,110,581 B2 9/2006 Xia et al.  
 7,124,300 B1 10/2006 Lemke  
 7,136,514 B1 11/2006 Wong  
 7,151,846 B1 12/2006 Fujii  
 7,233,686 B2 6/2007 Hamid  
 7,236,617 B1 6/2007 Yau et al.  
 7,327,859 B1 2/2008 Chau  
 7,369,688 B2 5/2008 Ser et al.  
 7,382,906 B2 6/2008 Meier  
 7,391,891 B2 6/2008 Hillhouse  
 7,400,749 B2 7/2008 Hillhouse  
 7,474,769 B1\* 1/2009 McAfee et al. .... 382/115  
 7,474,773 B2 1/2009 Chau  
 7,508,969 B2 3/2009 Shinbata  
 7,676,068 B2 3/2010 Cervantes  
 7,692,165 B2 4/2010 Winkler  
 7,697,730 B2 4/2010 Okamura et al.  
 7,742,626 B2 6/2010 Kamata et al.  
 7,773,870 B2 8/2010 Naruse  
 7,797,549 B2 9/2010 Main et al.  
 7,899,217 B2 3/2011 Uludag et al.  
 8,085,992 B1 12/2011 Sahin et al.  
 8,457,370 B2\* 6/2013 Sezille ..... G06K 9/00013  
 340/5.82  
 2001/0026632 A1 10/2001 Tamai  
 2002/0035542 A1 3/2002 Tumey et al.  
 2002/0056043 A1 5/2002 Glass  
 2002/0146169 A1 10/2002 Sukthakar et al.  
 2003/0169334 A1 9/2003 Braithwaite et al.  
 2004/0052405 A1 3/2004 Walfridsson  
 2004/0057604 A1 3/2004 David et al.  
 2004/0193893 A1 9/2004 Braithwaite et al.  
 2004/0264742 A1 12/2004 Zhang et al.  
 2005/0100199 A1\* 5/2005 Boshra ..... 382/124  
 2005/0175225 A1\* 8/2005 Shinzaki ..... 382/124  
 2006/0078170 A1 4/2006 Kamata et al.  
 2006/0182318 A1 8/2006 Shigeta  
 2007/0201694 A1\* 8/2007 Bolle et al. .... 380/205  
 2007/0201727 A1 8/2007 Birrell et al.  
 2008/0063244 A1 3/2008 Tanaka et al.  
 2008/0065901 A1 3/2008 Takaku et al.  
 2008/0101663 A1 5/2008 Lo et al.  
 2008/0148059 A1 6/2008 Shapiro  
 2008/0192988 A1 8/2008 Uludag et al.  
 2008/0226136 A1 9/2008 Takaku et al.  
 2008/0298642 A1 12/2008 Meenen  
 2009/0160609 A1 6/2009 Lin et al.

2009/0169072 A1 7/2009 Lo et al.  
 2009/0175506 A1\* 7/2009 Polcha et al. .... 382/116  
 2009/0208064 A1\* 8/2009 Cambier ..... G06K 9/0061  
 382/110  
 2009/0243798 A1 10/2009 Fukuda et al.  
 2009/0245585 A1 10/2009 Manabe et al.  
 2009/0304237 A1 12/2009 Yoshikawa et al.  
 2009/0310831 A1 12/2009 Zhang et al.  
 2010/0002927 A1 1/2010 Kalayeh  
 2010/0008545 A1 1/2010 Ueki et al.  
 2010/0030696 A1 2/2010 Naccache  
 2010/0033302 A1 2/2010 Yamamoto  
 2010/0135540 A1 6/2010 Cervantes  
 2010/0161488 A1 6/2010 Evans et al.  
 2010/0202665 A1 8/2010 Mohammad et al.  
 2010/0253471 A1 10/2010 Abe  
 2010/0316264 A1 12/2010 Ferren et al.  
 2010/0322484 A1 12/2010 Hama et al.  
 2010/0329568 A1 12/2010 Gamliel et al.  
 2011/0016317 A1 1/2011 Abe

FOREIGN PATENT DOCUMENTS

EP 1 562 134 A2 8/2005  
 EP 1 562 134 A3 8/2005  
 EP 1 903 509 A1 3/2008  
 EP 2 107 499 A1 10/2009  
 EP 2 244 224 A1 10/2010  
 JP 2001-273498 A 10/2001  
 JP 2005242908 A \* 9/2005  
 JP 2007-334659 12/2007  
 JP 2008-070926 A 3/2008  
 JP 2008-071030 3/2008  
 JP 2009-205576 9/2009  
 JP 2009-211357 9/2009  
 JP 2010-146158 A 7/2010  
 JP 2010-152706 A 7/2010  
 WO WO 2004/111919 A1 12/2004

OTHER PUBLICATIONS

Dennis Dunn et al.: "Optimal Gabor Filters for Texture Segmentation," IEEE Transactions on Image Processing, vol. 4, No. 7, Jul. 1995, pp. 947-964.  
 Extended European Search Report for EPO Application No. 12151316.2, dated May 22, 2012, pp. 1-12.  
 Xiang-Quin et al. "Fusion of Multiple Features for Palmprint Authentication," Machine Learning and Cybernetics, 2006 International Conference on, Aug. 13-16, 2006, p. 3260.  
 Zheng Liu et al.: "Using multiple orientational filters of steerable pyramid for image registration," vol. 3, No. 3, Sep. 1, 2002, pp. 203-214.  
 Bernd Jahne et al.: "Principles of Filter Design" In: Handbook of Computer Visions and Applications, vol. 2, Jul. 1, 1999, pp. 125-151.  
 Extended European Search Report for EPO Application No. 12151317.0, dated May 14, 2012, pp. 1-11.

\* cited by examiner

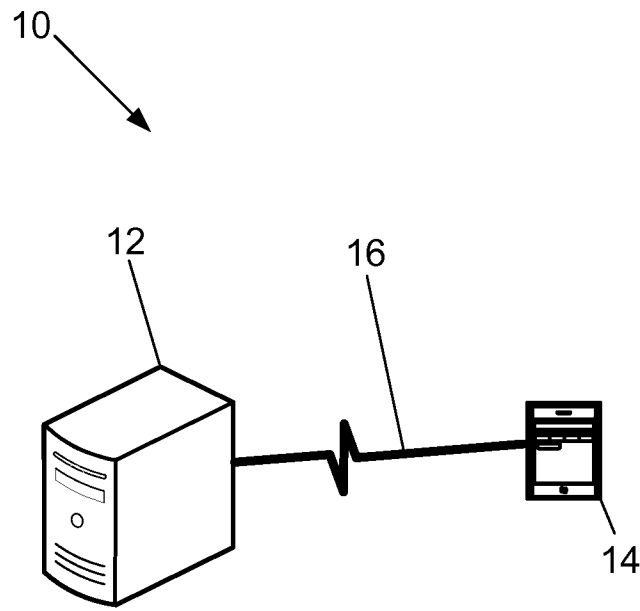

FIG. 1

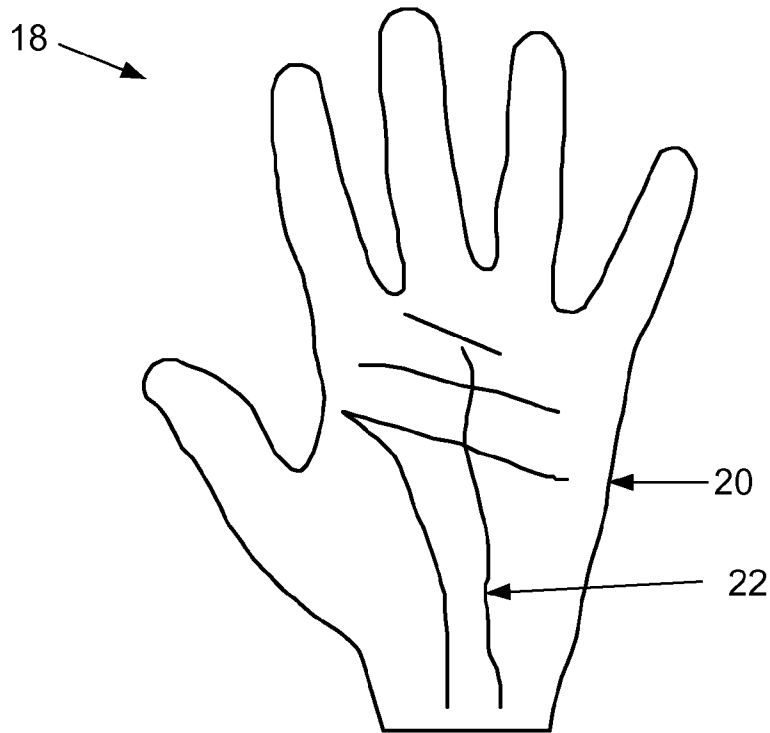

FIG. 2

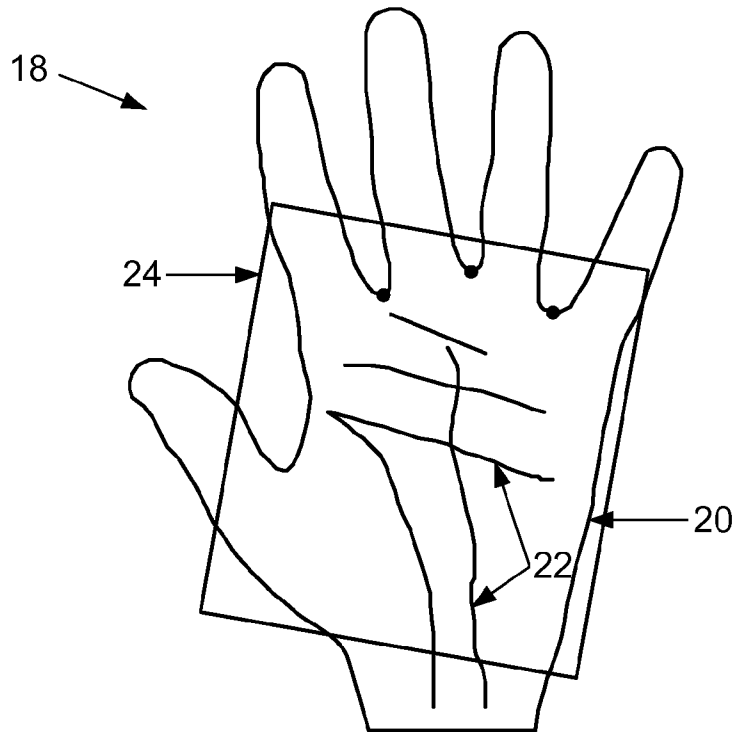

FIG. 3

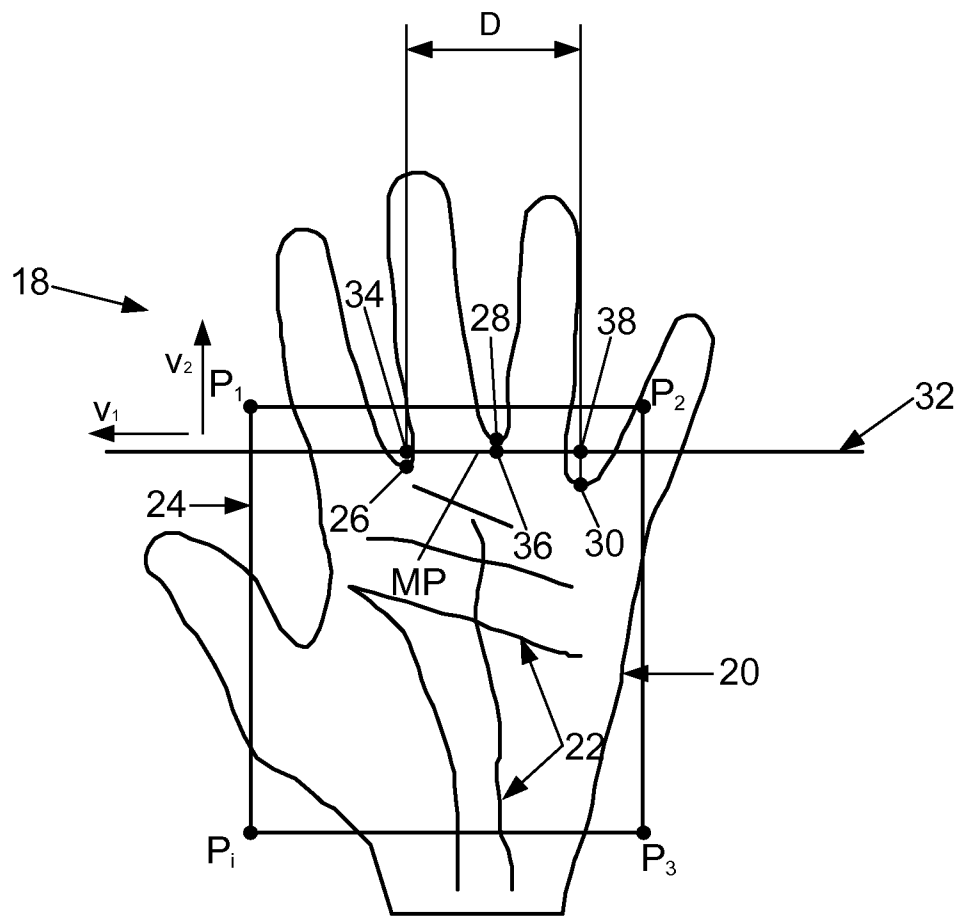

FIG. 4

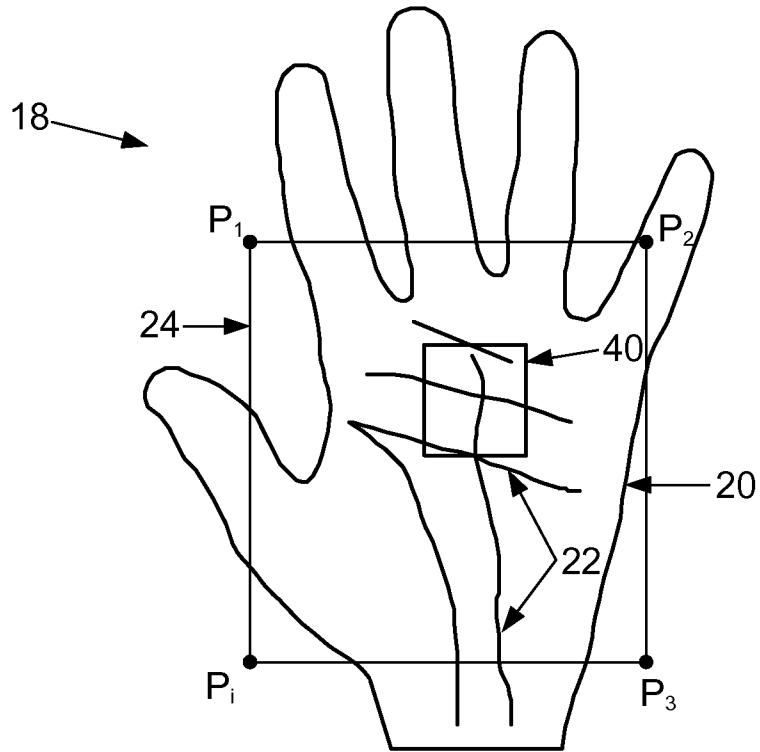

FIG. 5

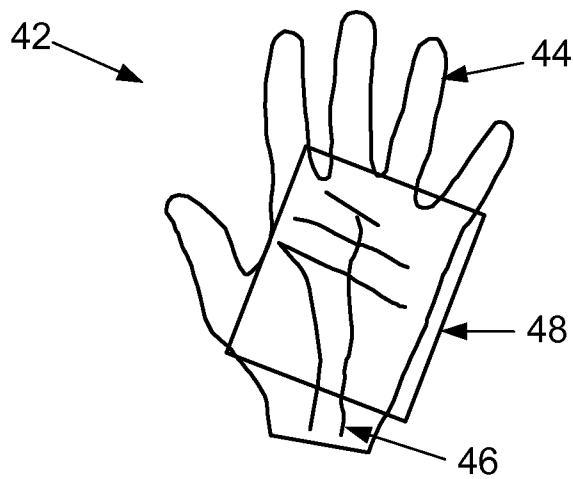

FIG. 6

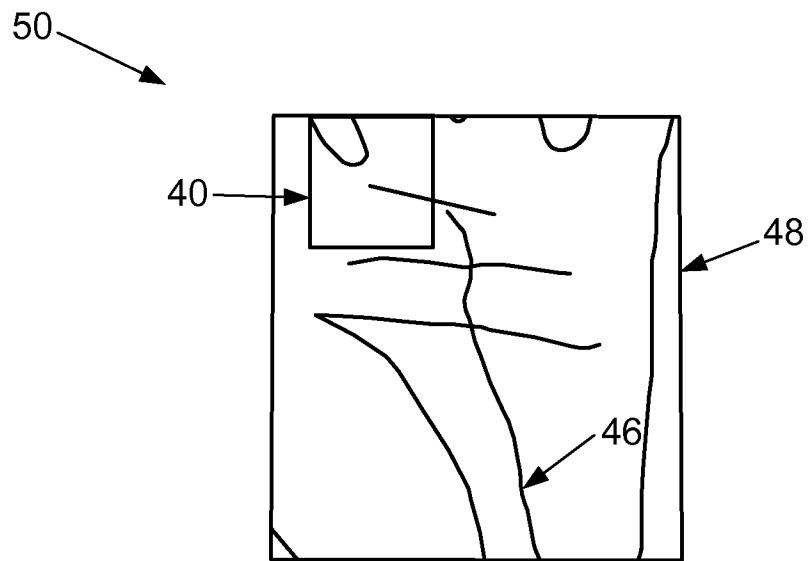

FIG. 7

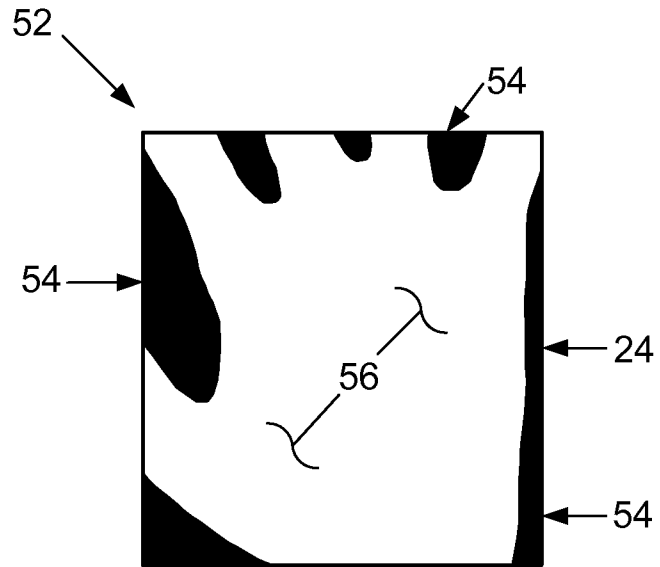

FIG. 8

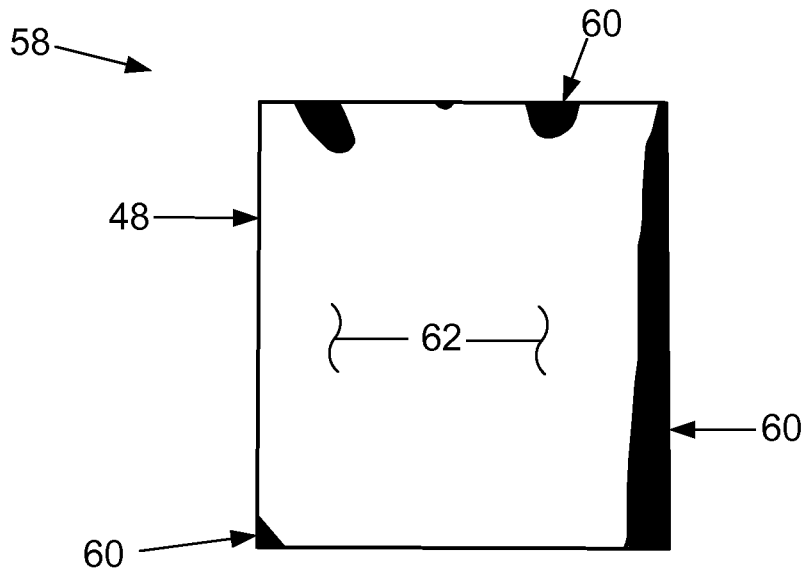

FIG. 9



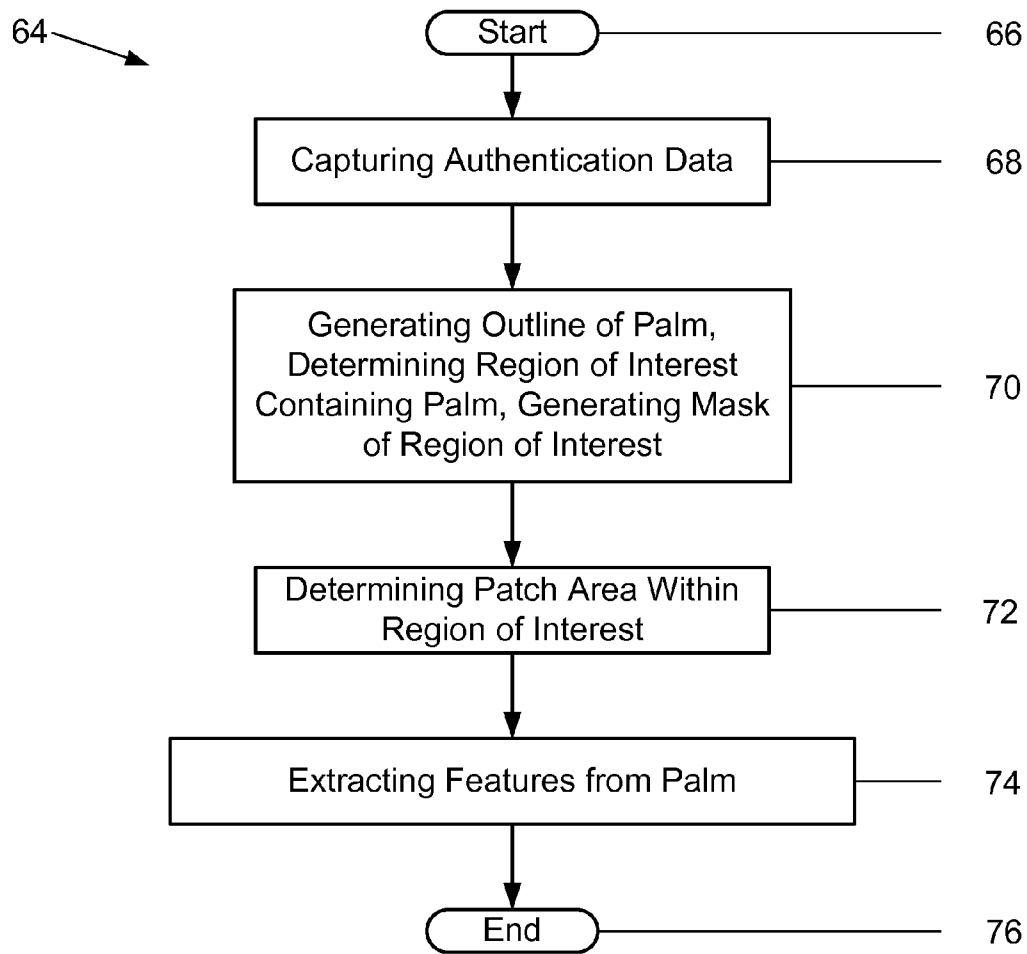

FIG. 10

78 ↘

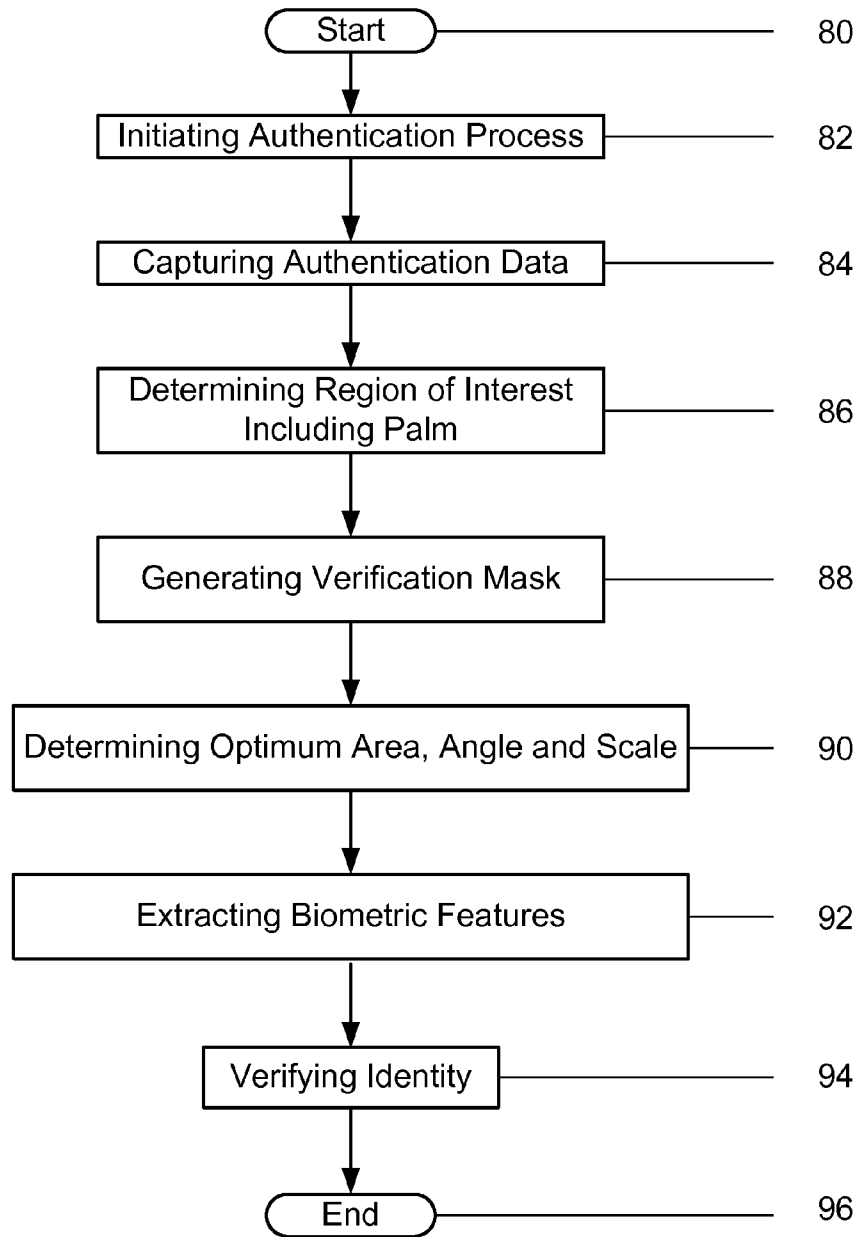

FIG. 11

1

## METHODS AND SYSTEMS FOR AUTHENTICATING USERS

### CROSS-REFERENCE TO RELATED APPLICATIONS

This is a continuation application of U.S. patent application Ser. No. 13/010,443, filed Jan. 20, 2011, now U.S. Pat. No. 8,457,370, issued Jun. 4, 2013.

### BACKGROUND OF THE INVENTION

This invention relates generally to methods and systems for authenticating users over networks, and more particularly, to methods and systems of authenticating users with palm biometric data captured with devices readily available to users.

Known palm print biometric data capture devices are generally very high quality optical devices that capture images at resolutions ranging from about five hundred to one thousand dots per inch. Such palm print data capture devices typically include a platen and an instrument positioned a fixed distance from the platen. During operation, a palm is placed on the platen in a known orientation and the instrument captures an image of the palm. Because the palm is placed on the platen, the orientation and size of the palm print may be accurately determined during operation. Such palm print capture devices are known to capture very high quality images that include biometric features such as, but not limited to, ridge lines and minutia points. Minutia points and ridge lines are also present in fingerprint biometric data. Consequently, police departments and other similar law enforcement agencies typically have access to palm print biometric data capture devices because such agencies prefer to capture palm print biometric data as well as fingerprint biometric data when booking suspects.

However, existing palm print capture devices are generally large and cumbersome, and include complex sensitive components that may be damaged when moved. Thus, known palm print data capture devices are not typically portable. Moreover, palm print capture devices are not available to the general public because they are typically located at law enforcement agencies. Furthermore, by requiring palm placement on the platen in a known orientation, existing palm print capture devices do not allow for moving a hand freely in space while capturing the palm biometric data. Thus, palm print biometric data may not be captured for physically handicapped individuals incapable of placing their palms on the platen in the required orientation. Additionally, known palm print capture devices are expensive.

As a result, capturing palm print biometric data with known palm print biometric capture devices may be inconvenient or impossible for members of the general public, and may be expensive.

### BRIEF DESCRIPTION OF THE INVENTION

In one aspect, a method of authenticating users is provided that includes capturing biometric authentication data of a user and processing the captured biometric data into an image. Moreover, the method includes determining a region of interest of the image and a gray scale image from the image, determining an optimum transformation parameter set within the region of interest, and aligning the gray scale image with an enrollment gray scale image generated during enrollment of the user using results of the optimum trans-

2

formation parameter set determination. Furthermore, the method includes extracting biometric feature data from the gray scale image and verifying an identity of the user with extracted biometric feature data included in a region of agreement.

In another aspect, a system for authenticating a user is provided that includes an authentication system including an authentication database. The authentication system is configured to communicate with devices and to store within the authentication database authentication data for a plurality of users. Moreover, the system includes a device configured to communicate with at least the authentication system and to capture authentication data. The authentication system is further configured to determine a region of interest of authentication data captured by the device, and calculate a transformation for aligning the region of interest with an enrollment region of interest determined during enrollment of the user in the authentication system.

In yet another aspect, a method for authenticating a user is provided that includes capturing authentication data from the user and processing the captured authentication data into an image, determining a region of interest of the image, and calculating a transformation for aligning the region of interest with an enrollment region of interest determined during enrollment of the user.

### BRIEF DESCRIPTION OF THE DRAWINGS

FIG. 1 is a block diagram of an exemplary embodiment of an Authentication Computer (AC) System for authenticating users;

FIG. 2 is a plan view of an exemplary palm image captured during enrollment;

FIG. 3 is the plan view of the exemplary palm image as shown in FIG. 2 including a region of interest;

FIG. 4 is the plan view of the exemplary palm image as shown in FIG. 3, further including a best fit line;

FIG. 5 is the plan view of the exemplary palm image as shown in FIG. 3 including a patch area;

FIG. 6 is a plan view of an exemplary palm image captured during identity authentication;

FIG. 7 is a plan view of the region of interest shown in FIG. 6 including the patch area;

FIG. 8 is a plan view of an exemplary mask of the palm image captured during enrollment;

FIG. 9 is a plan view of an exemplary mask of a palm image captured during authentication;

FIG. 10 is a flowchart illustrating an exemplary enrollment process; and

FIG. 11 is a flowchart illustrating an exemplary authentication process.

### DETAILED DESCRIPTION OF THE INVENTION

FIG. 1 is an expanded block diagram of an exemplary embodiment of a system architecture of an Authentication Computer (AC) System 10 for authenticating the identity of a user. More specifically, the AC system 10 includes a Biometric Authentication Computer (BAC) System 12 and a device 14.

The BAC system 12 includes components such as, but not limited to, a web server, a disk storage device, a database management server and an authentication server arranged to be combined into a single structure. Although these components are combined into a single structure in the exemplary embodiment, it should be appreciated that in other

embodiments these components may be separately positioned at different locations and operatively coupled together in a network such as, but not limited to, a local area network (LAN), a wide area network (WAN) and the Internet. The disk storage device may be used for storing any kind of data including, but not limited to, enrollment data records of individuals, rotation angles, scale factors, coordinates and correlation factors. The database management server may be used to facilitate transferring data to and from the disk storage device. The authentication server is configured to perform matching of any feature or information associated with individuals to authenticate the identity of individuals as described herein.

The BAC system **12** is configured to wirelessly communicate with the device **14** over a communications network **16** in the exemplary embodiment. Moreover, the BAC system **12** is operable to facilitate authenticating identities of users operating the device **14**. In the exemplary embodiment, the communications network **16** is a 3G communications network. However, it should be appreciated that in other embodiments the communications network **16** may be any network that facilitates authentication as described herein, such as, but not limited to, W-Fi, Global System for Mobile (GSM), Enhanced Data for GSM Environment (EDGE), a LAN, a WAN and the Internet. The BAC system **12** is also operable to calculate transformations, apply the transformations to biometric data and images, determine coordinates of points, apply rotation angles and scale factors to biometric data and images, and calculate correlation factors.

The BAC system **12** is operable to store authentication data. In the exemplary embodiment, the authentication data is palm biometric data. In other embodiments, biometric authentication data corresponding to any biometric type may be used as the basis of authentication. Such biometric types include, but are not limited to, foot, face, fingerprint, iris, voice, vascular patterns and hand signatures. Thus, the BAC system **12** is operable to store biometric authentication data and is operable to use the biometric authentication data to authenticate identities of users. Using biometrics as the basis for authentication facilitates enhancing trust in the authentication result. In order to facilitate properly authenticating users, in the exemplary embodiment the BAC system **12** stores biometric authentication data in the form of enrollment data records for each of a plurality of enrolled users. Biometric data to be used as the basis of authentication is captured from users during enrollment and is stored as enrollment data records in the BAC system **12**. Moreover, the biometric data may take any form such as, but not limited to, images, photographs, templates and electronic data representations.

Although the enrollment data records include biometric data in the exemplary embodiment, it should be appreciated that in other embodiments the enrollment data records may include any kind of authentication data including, but not limited to, biographic data, and may include any combination of authentication data for each authorized user. Moreover, it should be appreciated that in other embodiments the enrollment data records may include biographic data, in addition to the biometric data, for each enrolled user that is associated with the enrolled user's biometric data.

The BAC system **12** may store authentication policies therein which are used to determine data that is to be obtained from a user attempting to enroll in the BAC system **12**. Moreover, additional authentication policies may be used to determine data to be obtained from a user requesting biometric authentication with the device **14**.

The term "biographic data" as used herein includes any demographic information regarding an individual as well as contact information pertinent to the individual. Such demographic information includes, but is not limited to, an individual's name, age, date of birth, address, citizenship and marital status. Contact information collected in the exemplary embodiment includes devices and methods for contacting the enrolled user.

The device **14** is configured to wirelessly communicate with at least the BAC system **12** over the network **16**. Moreover, in the exemplary embodiment, the device **14** is operable to capture authentication data from users. The device **14** includes at least one of buttons and icons operable to at least enter commands, enter data and invoke applications stored therein. Moreover, the device **14** includes a display screen such as, but not limited to, a Liquid Crystal Display (LCD), and is operable to display any text or image on the display screen. In the exemplary embodiment, the device **14** is a smart phone operable to at least display messages and images, capture authentication data from a user, and transmit the captured authentication data to the BAC system **12**.

Although the device **14** is a smart phone in the exemplary embodiment, it should be appreciated that in other embodiments the device **14** may be any device capable of at least communicating with the BAC system **12**, displaying messages and images, and capturing and transmitting data. Such other devices **14** include, but are not limited to, a tablet computer, a television, a camera, a personal desktop computer, a laptop computer, and a personal digital assistant (PDA). The device **14** may be used to obtain the authentication data stored as enrollment data records in the BAC system **12**. Furthermore, authentication data obtained during authentication is captured using the device **14** in the exemplary embodiment. It should be appreciated that in other embodiments the enrollment data records may be obtained in any manner that facilitates authenticating the identity of users as described herein, including, but not limited to, loading the required authentication data into the BAC system **12** from external identity management systems or human resource management systems.

The memories (not shown) in the BAC **12** and the device **14** can be implemented using any appropriate combination of alterable, volatile or non-volatile memory or non-alterable, or fixed, memory. The alterable memory, whether volatile or non-volatile, can be implemented using any one or more of static or dynamic RAM (Random Access Memory), a floppy disc and disc drive, a writeable or re-writeable optical disc and disc drive, a hard drive, flash memory or the like. Similarly, the non-alterable or fixed memory can be implemented using any one or more of ROM (Read-Only Memory), PROM (Programmable Read-Only Memory), EPROM (Erasable Programmable Read-Only Memory), EEPROM (Electrically Erasable Programmable Read-Only Memory), an optical ROM disc, such as a CD-ROM or DVD-ROM disc, and disc drive or the like.

Each memory (not shown) can be a computer-readable recording medium used to store data in the BAC system **12** and the device **14**, and store computer programs or executable instructions that are executed by the BAC system **12** and the device **14**. Moreover, the memory (not shown) may include smart cards, SIMs or any other medium from which a computing device can read computer programs or executable instructions. As used herein, the term "computer program" is intended to encompass an executable program that exists permanently or temporarily on any computer-readable

5

recordable medium that causes the computer or computer processor to execute the program.

FIG. 2 is a plan view of an exemplary palm image 18, including an outline 20 of the palm and biometric features 22, captured during enrollment in the BAC system 12. The palm image 18 constitutes biometric data captured from a user with the device 14. In the exemplary embodiment, the biometric features 22 are lines and wrinkles. In other embodiments the biometric features 22 may be any biometric feature including, but not limited to, ridge lines and minutia points. The lines and wrinkles within the palm image 18 are determined and are included as data points in a generated biometric feature template. In the exemplary embodiment, the biometric features are extracted from the captured biometric data by the BAC system 12 and are included as data in a biometric feature template generated by the BAC system 12. Biometric feature templates are usually a compact representation of the biometric features included in the captured biometric data, and are used for authenticating individuals. The raw captured biometric data may be stored in the BAC system 12 or in a server system different than the BAC system 12.

Although the captured biometric data is from a palm in the exemplary embodiment, it should be appreciated that in other embodiments biometric data of different biometric types may be captured. Such different biometric types include, but are not limited to, face, voice, iris, and foot. Moreover, it should be appreciated that such different biometric types may have biometric features, different than wrinkles and lines, that can be extracted from the captured biometric data and included in a biometric feature template. For example, when iris biometric data is captured during authentication, phase information and masking information of the iris may be extracted from the captured iris biometric data and included in a biometric feature template. Although the captured biometric data is processed into a biometric feature template in the exemplary embodiment, it should be appreciated that in other embodiments the captured biometric data may be processed into any form that facilitates authenticating the individual, such as, but not limited to, photographs, images and electronic data representations.

FIG. 3 is the plan view of the exemplary palm image 18 as shown in FIG. 2, further including an enrollment region of interest 24. In the exemplary embodiment, the enrollment region of interest 24 is square-shaped. However, in other embodiments the enrollment region of interest 24 may have any shape including, but not limited to, rectangle and circle. The enrollment region of interest 24 includes the palm of the hand.

FIG. 4 is the plan view of the palm image as shown in FIG. 3, further including a best fit line for use in constructing the enrollment region of interest 24. In the exemplary embodiment, the enrollment region of interest is constructed by first establishing coordinates of points 26, 28, 30. Points 26, 28, 30 are each positioned at the base between different fingers. Next, constructing the enrollment region of interest 24 continues by determining a line 32 that constitutes a best fit between points 26, 28, 30, and determining a normal projection from each point 26, 28, 30 to the best fit line 32. Each normal projection intersects the best fit line to define further points 34, 36, 38, respectively. The coordinates of points 34, 36, 38 are determined. A distance D is determined between points 34 and 38 that may be referred to as a scale identifying number or a scale factor. Next, the coordinates of a midpoint MP between points 34 and 38 are determined, and a vector  $v_1$  parallel to the best fit line and a vector  $v_2$  normal to the best fit line 32 are determined. The scale

6

identifying number D, the coordinates of the midpoint MP, and the vectors  $v_1$  and  $v_2$  are then substituted into the equation  $P_i = MP + a_1 D v_1 + b_1 D v_2$  to determine the coordinates of each corner of the region of interest 24. The designation “i” as used in conjunction with the corner points  $P_i$ , is intended to indicate that any number “i” of corner points, appropriate for any geometric shape, may be used that facilitates authenticating the identity of a user as described herein. It should be appreciated that  $a_1$  and  $b_1$  designate coefficients that facilitate determining the coordinates of corner points  $P_i$ . By virtue of determining the coordinates of points  $P_i$  it should be appreciated that the enrollment region of interest 24 is defined.

Although the exemplary embodiment determines the enrollment region of interest 24 by calculating the coordinates of each corner using an equation, it should be appreciated that differently shaped enrollment regions of interest 24 may be determined using other methods, equations or mathematical relationships. It should be understood that the palm image 18 includes a first Cartesian coordinate system and that the coordinates calculated during construction of the enrollment region of interest 24 are from the first Cartesian coordinate system. It should also be understood that the enrollment region of interest 24 includes a second Cartesian coordinate system.

FIG. 5 is the plan view of the palm image 18 as shown in FIG. 3, further including a patch area 40. In the exemplary embodiment, the patch area 40 is rectangular-shaped, has a fixed size that is smaller than the enrollment region of interest 24, and is positioned at a center of gravity of the palm. It should be understood that the patch area 40 is not merely a rectangular geometric shape superimposed on the palm. Rather, the patch area 40 represents a copy of a portion of the palm image 18 within the bounds of the patch area 40. The coordinates of the center of gravity of the palm are calculated in accordance with the second Cartesian coordinate system. Next, the center of the patch area 40 is positioned to be coincident with the center of gravity. Thus, after positioning the patch area 40 on the center of gravity, the center of the patch area 40 has the same coordinates as the center of gravity. In the exemplary embodiment sides of the patch area 40 are parallel to the sides of the enrollment region of interest 24. However, in other embodiments the sides of the patch area 40 are not parallel to the sides of the enrollment region of interest 24.

It should be understood that the position of the enrollment region of interest 24 and the position of the patch area 40 are not related. However, the patch area 40 is to be positioned completely within the enrollment region of interest 24. Although the patch area is rectangular-shaped in the exemplary embodiment, in other embodiments the patch area 40 may have any shape including, but not limited to, square and circle. Moreover, in other embodiments instead of positioning the center of the patch area 40 coincident with the center of gravity, the patch area 40 may be positioned at areas on the palm image 18 that have a higher density of biometric features than other areas of the palm image 18. A template of the patch area 40 and a template of the enrollment region of interest 24 are generated by the BAC system 12 and stored therein.

FIG. 6 is a plan view of an exemplary palm image 42, including an outline 44 of the palm and biometric features 46, captured during authentication. It should be appreciated that the biometric data captured during authentication is captured at a different, but similar, orientation as the biometric data captured during enrollment in the BAC system 12. Moreover, the size of an image processed from the

biometric data captured during authentication may be different than the size of an image processed from biometric data captured during enrollment in the BAC system 12. Thus, in order to properly align differently oriented and differently sized images of the same biometric type, in the exemplary embodiment, a region of interest associated with one of the images is selected to be manipulated. Specifically, the size of the selected region of interest is increased or decreased by a scale factor such that the selected region of interest size is substantially similar to the size of a region of interest of the non-selected image. Furthermore, the selected region of interest is rotated to have substantially the same orientation as the non-selected region of interest. By thus manipulating the selected region of interest, the selected image and the non-selected image may be substantially aligned with each other.

For example, the palm image 42 of FIG. 6 is smaller than, and has a different orientation than, the palm image 18 of FIG. 5. By increasing the size of an authentication region of interest 48 associated with the palm image 42 and rotating the region of interest 48 counterclockwise, palm image 42 may be manipulated to be substantially the same size as the palm image 18 and to have substantially the same orientation as the palm image 18. By virtue of having substantially the same size and orientation, the palm images 18 and 42 may be substantially aligned with each other.

The biometric features 46 are lines and wrinkles in the exemplary embodiment. However, in other embodiments the biometric features 46 may be any biometric feature including, but not limited to, ridge lines and minutia points. The authentication region of interest 48 is determined in a substantially identical way as the enrollment region of interest 24. The authentication region of interest 48 has the same coordinate system as the enrollment region of interest 24. Thus, the authentication region of interest 48 includes the second Cartesian coordinate system.

FIG. 7 is a plan view of the palm image 42 located within the authentication region of interest 48. The palm image located within the authentication region of interest 48 is referred to herein as a gray scale image 50. The patch area 40 determined during enrollment in the BAC system 12 is used to facilitate determining an optimum area of the gray scale image 50 that best correlates to the patch area 40. Specifically, the patch area 40 is incrementally positioned over the entire gray scale image 50. At each position, the patch area 40 is compared against the palm biometric data encompassed by the patch area 40 such that a correlation score is determined for each position. The correlation score indicates the correlation between the patch area 40 and a corresponding matching area of the gray scale image 50. Comparing the patch area 40 against the gray scale image 50 and generating the correlation scores is referred to herein as applying the patch area 40 against the gray scale image 50. It should be understood that the gray scale image 50 is rotated through a series of angles and at the same time is scaled through a series of scale factors. For each rotation angle and scale factor combination, the patch area 40 is applied against the gray scale image 50.

After calculating the correlation scores for each desired rotation angle and scale factor combination, the best correlation score is determined. Optimum transformation parameters are determined to be the rotation angle and the scale factor that correspond to the best correlation score, as well as the center point coordinates of the matching area that corresponds to the best correlation score. The matching area that corresponds to the patch area 40 at the best correlation score is the optimum area of the gray scale image 50. The

gray scale image 50 is then adjusted by the rotation angle and scale factor corresponding to the best correlation score, and the coordinates of the matching area in the gray scale image 50 are calculated using the second Cartesian coordinate system. The rotation angle and the scale factor of the optimum area are also referred to as the optimum rotation angle and the optimum scale factor. The optimum rotation angle, optimum scale factor and the coordinates of the optimum area, together constitute an optimum transformation parameter set. It should be understood that the authentication region of interest 48 may also be used to generate an authentication mask. Thus, by virtue of knowing the coordinates of the patch area 40 in the enrollment region of interest 24, the optimum rotation angle, the optimum scale factor, and the coordinates of the optimum area center point, a transformation necessary for substantially aligning the authentication region of interest 48 with the enrollment region of interest 24 may be calculated. Likewise, the transformation may be calculated for substantially aligning the authentication mask with an enrollment mask generated during enrollment, and for substantially aligning the gray scale image 50 with an enrollment gray scale image generated during enrollment. Thus, the transformation is applied against the authentication mask to substantially align the authentication and enrollment masks. The transformation is also applied against the gray scale image 50 to substantially align the gray scale image 50 with the enrollment gray scale image.

After aligning the authentication and enrollment masks, and aligning the gray scale image 50 and the enrollment gray scale image, a biometric template is generated from the aligned gray scale image 50. The authentication and enrollment masks are compared to determine a region common to both masks. Biometric template data generated from the aligned gray scale image 50 that is also within the common region is used to conduct a biometric authentication matching transaction. The common region may also be referred to as a region of agreement.

In the exemplary embodiment the authentication region of interest 48 is rotated, from its original orientation, through angles ranging from ten degrees clockwise to ten degrees counterclockwise. However, in other embodiments the authentication region of interest 48 may be rotated by angles greater than ten degrees in either the clockwise or counterclockwise directions. Moreover, scale factors are applied to the authentication region of interest 48 that increase and decrease the size of the region of interest 48 by up to twenty percent. However, in other embodiments other scale factors may be applied that increase or decrease the size of the authentication region of interest 48 by greater than twenty percent.

It should be understood that the authentication mask and the gray scale image 50 each include the authentication region of interest 48. Thus, all information or data included in the authentication mask and the gray scale image 50 are rotated and scaled as described above for the authentication region of interest 48. Computations relating to determination of the optimum area are conducted in the second Cartesian coordinate system.

FIG. 8 is a plan view of an enrollment mask 52 generated from the enrollment region of interest 24 during enrollment. The enrollment mask 52 includes shaded areas that represent areas not containing valid biometric data within the enrollment region of interest 24. The mask 52 also includes another area 56 that represents areas containing valid biometric data within the enrollment region of interest 24.

FIG. 9 is a plan view of an authentication mask 58 generated from the authentication region of interest 48 during authentication. The mask 58 includes shaded areas 60 that represent areas not containing valid biometric data within the authentication region of interest 48. The authentication mask 58 also includes another area 62 that represents areas containing valid biometric data within the authentication region of interest 48. During authentication, the enrollment mask 52 and the authentication mask 58 are compared to define a region common to both masks 52, 58. Biometric data within the common region is used for matching during authentication.

FIG. 10 is a flowchart 64 illustrating an exemplary process for enrolling users in the BAC system 12. The enrolling process starts 66 by activating a security application stored in the device 14. The user activates the device 14. The security application causes the device 14 to display a message prompting the user to capture requested biometric data. The requested biometric data is an image of a palm of the user, including fingers. Next, processing continues by capturing biometric authentication data 68 in accordance with the message from the user with the device 14. Specifically, in the exemplary embodiment the biometric authentication data is captured by taking a picture of the user's palm, including fingers, with the device 14. Thus, the biometric data is captured and processed into an image. In the exemplary embodiment a single picture is taken during enrollment. However, in other embodiments any number of pictures may be taken that facilitate authenticating the identity of a user as described herein. The captured biometric data is communicated to the BAC system 12.

Next, processing continues by generating an outline of the palm 70, determining 70 the enrollment region of interest 24, and generating 70 the enrollment mask 52. The palm outline, enrollment region of interest 24, and enrollment mask 52 are stored in the enrollment data record of the user in the BAC system 12.

Processing continues by determining 72 the patch area 40 within the enrollment region of interest 24. Each patch area 40 is processed into a patch area template and is stored in the enrollment data record of the user. After determining 72 the patch area 40, processing continues by extracting biometric features 74 from the palm included in the enrollment region of interest 24. The extracted biometric features are processed into a biometric template which is stored in the enrollment data record of the user. After extracting the biometric features 74, a message is communicated to, and displayed on, the device 14 notifying the user that enrollment is complete. Next, enrollment processing ends 76.

FIG. 11 is a flowchart 78 illustrating an exemplary authentication process used by the AC system 10 for authenticating the identity of a user. For AC system 10, the process starts 80 by initiating an authentication process 82. Specifically, a user initiates the authentication process by activating the security application in the device 14 when the user desires to be authenticated. It should be appreciated that the user may desire to be authenticated in many different circumstances including, but not limited to, when remotely conducting a transaction and when requested by security personnel to prove a claim of identity.

The security application causes the device 14 to display a message prompting the user to capture requested biometric data. As during enrollment, the requested biometric data is an image of the palm of the user, including fingers. Processing continues by capturing authentication data in accordance

with the message by taking a picture of the user's palm with the device 14. Thus, the biometric authentication data is captured and processed into an image. The captured biometric data is communicated to the BAC system 12. In the exemplary embodiment a single picture is taken during authentication. However, in other embodiments any number of pictures may be taken.

Next, processing continues by determining 86 the authentication region of interest 48 including the palm from the captured biometric data, and generating 88 the authentication mask 58 and the gray scale image 50 for the captured biometric data. Processing continues by determining the optimum area 90 within the authentication region of interest 48, and adjusting the scale and angle of the authentication region of interest 48 such that the adjusted authentication region of interest 48 substantially aligns with the enrollment region of interest 24. The authentication and enrollment masks, and the gray scale image 50 and enrollment gray scale image are similarly substantially aligned with each other. Next, processing continues by extracting biometric features 92 from the aligned gray scale image 50 and generating biometric template data from the extracted data. The aligned authentication and enrollment masks are compared to determine the region of agreement. Biometric template data that is within the region of agreement is used to conduct a biometric verification matching transaction.

Processing continues by verifying the identity 94 of the user. Specifically, the biometric template data within the region of agreement is compared against corresponding template data of the enrollment template data record and a matching score is generated. The matching score is compared against a predetermined threshold to determine whether the identity of the user is verified. When the identity of the user is verified a message is communicated to, and displayed on, the device 14 notifying the user of the verification, and processing ends 96. When the identity of the user is not verified, a message is communicated to, and displayed on, the device 14 notifying the user that his identity was not verified, and processing ends 96.

In each embodiment, the above-described processes facilitate aligning biometric data captured during authentication with enrollment biometric data. More specifically, a transform is calculated and is applied to the biometric data captured during authentication. The transform causes the captured biometric data to have substantially the same size and orientation as the enrollment biometric data. As a result, biometric authentication data capture devices readily available to users may be used for accurate and proper authentication.

Exemplary embodiments of processes and systems that facilitate convenient, flexible and inexpensive biometric authentication based on palm biometric data are described herein. The processes are not limited to use with the specific computer system embodiments described herein, but rather, the processes can be utilized independently and separately from other processes described herein. Moreover, the invention is not limited to the embodiments of the processes and systems described above in detail. Rather, other variations of the processes may be utilized within the spirit and scope of the claims.

While the invention has been described in terms of various specific embodiments, those skilled in the art will recognize that the invention can be practiced with modification within the spirit and scope of the claims.

11

What is claimed is:

- 1. A method of authenticating users comprising:
  - generating, by a processor, an authentication mask from captured biometric data, the biometric data being captured from a user during an authentication matching transaction;
  - generating a gray scale image from the captured biometric data;
  - aligning the authentication mask with a user enrollment mask and the gray scale image with a second user gray scale image;
  - generating a biometric template from the aligned gray scale image;
  - comparing, by the processor, the authentication mask against the user enrollment mask to determine a region common to both; and
  - authenticating, by the processor, the user with biometric data, included in the biometric template, within the common region.
- 2. A method of authenticating users in accordance with claim 1 said aligning step further comprising applying a transformation against the authentication mask and the gray scale image.
- 3. A computing device for authenticating users comprising:
  - a processor; and
  - a memory configured to store at least enrollment masks and gray scale images, said computing device being associated with a network and said memory being in communication with said processor and having instructions stored thereon which, when executed by said processor, cause said computing device to:
    - generate an authentication mask from captured biometric data, the biometric data being captured from a user during an authentication matching transaction;
    - generate a gray scale image from the captured biometric data;
    - align the authentication mask with a user enrollment mask and the generated gray scale image with a user gray scale image;

12

- generate a biometric template from the aligned gray scale image;
- compare the authentication mask against the user enrollment mask to determine a region common to both; and authenticate the user with biometric data, included in the biometric template, within the common region.
- 4. A computing device for authenticating users in accordance with claim 3, wherein when executed by said processor, the instructions further cause said computing device to apply a transformation against the authentication mask and the generated gray scale image to align the masks and gray scale images.
- 5. A computer program recorded on a non-transitory computer-readable recording medium included in a computing device for authenticating users, the computer program being comprised of instructions, which when read and executed by the computing device, cause the computing device to:
  - generate an authentication mask from captured biometric data, the biometric data being captured from a user during an authentication matching transaction;
  - generate a gray scale image from the captured biometric data;
  - align the authentication mask with a user enrollment mask and the generated gray scale image with a user gray scale image;
  - generate a biometric template from the aligned gray scale image;
  - compare the authentication mask against the user enrollment mask to determine a region common to both; and authenticate the user with biometric data, included in the biometric template, within the common region.
- 6. A computer program in accordance with claim 5 further comprising instructions, which when read and executed by the computing device, cause the computing device to apply a transformation against the authentication mask and the generated gray scale image to align the masks and gray scale images.

\* \* \* \* \*