



US009519002B2

(12) **United States Patent**
Nordberg et al.

(10) **Patent No.:** **US 9,519,002 B2**
(45) **Date of Patent:** **Dec. 13, 2016**

(54) **DEVICE, SYSTEM, AND METHOD FOR SELECTING A TARGET ANALYTE**

USPC 422/508, 509, 511, 515, 524, 525
See application file for complete search history.

(71) Applicant: **RareCyte, Inc.**, Seattle, WA (US)

(56) **References Cited**

(72) Inventors: **Joshua Nordberg**, Bainbridge Island, WA (US); **Steve Quarre**, Woodinville, WA (US)

U.S. PATENT DOCUMENTS

(73) Assignee: **RareCyte, Inc.**, Seattle, WA (US)

(*) Notice: Subject to any disclaimer, the term of this patent is extended or adjusted under 35 U.S.C. 154(b) by 154 days.

- 2,610,541 A * 9/1952 Rowland, Jr. G01N 21/51
250/214 R
- 5,525,302 A * 6/1996 Astle B01L 3/0279
422/511
- 5,639,426 A * 6/1997 Kerr B01L 3/0275
422/501
- 5,705,814 A * 1/1998 Young B82Y 35/00
250/307
- 7,343,724 B1 * 3/2008 Williams A61J 3/074
53/281
- 2002/0153909 A1 * 10/2002 Petersen G01R 1/073
324/755.01

(21) Appl. No.: **14/248,510**

(22) Filed: **Apr. 9, 2014**

(Continued)

(65) **Prior Publication Data**

US 2014/0308163 A1 Oct. 16, 2014

FOREIGN PATENT DOCUMENTS

Related U.S. Application Data

JP 2012522610 A 9/2012

(60) Provisional application No. 61/810,834, filed on Apr. 11, 2013, provisional application No. 61/922,931, filed on Jan. 2, 2014.

Primary Examiner — Jill Warden

Assistant Examiner — Brittany Fisher

(51) **Int. Cl.**

- B01L 3/02** (2006.01)
- G01N 35/10** (2006.01)
- G01N 15/10** (2006.01)

(57) **ABSTRACT**

This disclosure is directed to a device and a system for picking a target analyte of a suspension. A picker introduces at least one force, such as by a magnetic gradient and/or by a pressure gradient, to extract the target analyte from a specimen. The magnetic gradient may be introduced by a magnet, such as a permanent magnet or an electromagnet, and the pressure gradient may be introduced by a pump which moves within a fluid-primed cannula to create the pressure gradient, thereby drawing the target analyte into the cannula. The picker may also expel the target analyte onto or into a substrate, such as a well plate, after the target analyte has been drawn into the picker by reversing the pressure gradient or removing the magnetic gradient.

(52) **U.S. Cl.**

CPC **G01N 35/1009** (2013.01); **B01L 3/0217** (2013.01); **B01L 2200/0657** (2013.01); **B01L 2200/0668** (2013.01); **B01L 2400/0487** (2013.01); **G01N 2015/1006** (2013.01); **G01N 2015/1081** (2013.01)

(58) **Field of Classification Search**

CPC G01N 35/10; G01N 35/1002; G01N 35/1009; B01L 3/0217

6 Claims, 11 Drawing Sheets

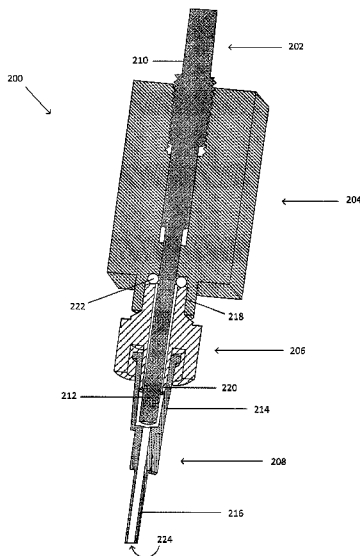

(56)

References Cited

U.S. PATENT DOCUMENTS

2003/0039589 A1* 2/2003 Smith B01L 3/0275
422/513
2006/0183217 A1* 8/2006 Yanagida B01L 3/50851
435/287.2
2008/0227663 A1* 9/2008 Tisone B01J 19/0046
506/39
2008/0296157 A1* 12/2008 Bauer B03C 1/288
204/557
2009/0017554 A1* 1/2009 Vann B01F 11/0071
436/172
2009/0177192 A1* 7/2009 Rioux A61C 7/08
606/33
2010/0043575 A1 2/2010 Tajima
2010/0119416 A1 5/2010 Tajima
2010/0140182 A1 6/2010 Chapman
2012/0091008 A1* 4/2012 Muir G01N 27/333
205/316
2012/0291567 A1* 11/2012 Homberg B01L 3/0237
73/864.13
2013/0074614 A1 3/2013 Holmes

* cited by examiner

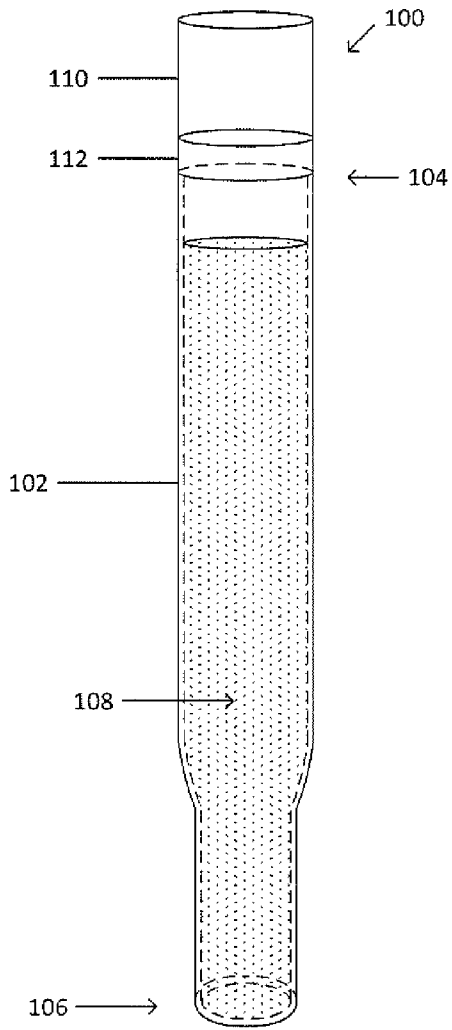

Fig. 1A

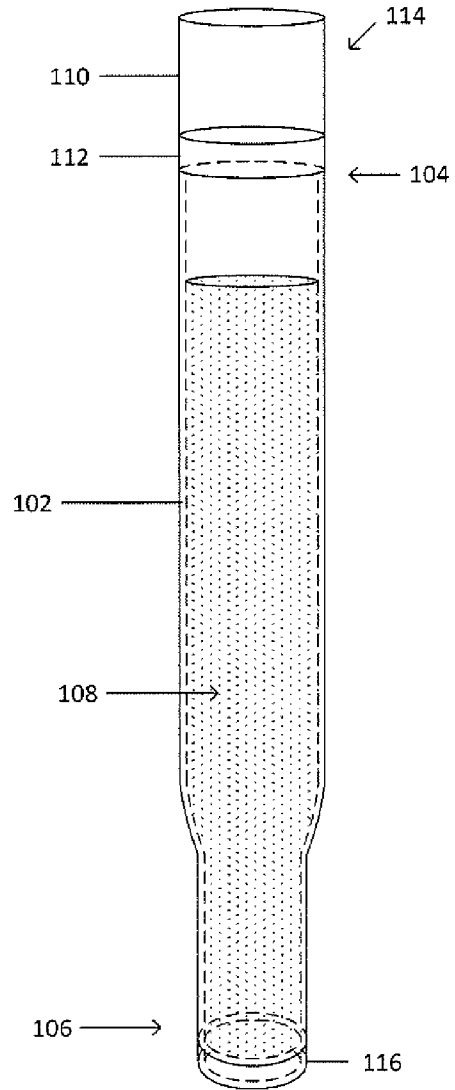

Fig. 1B

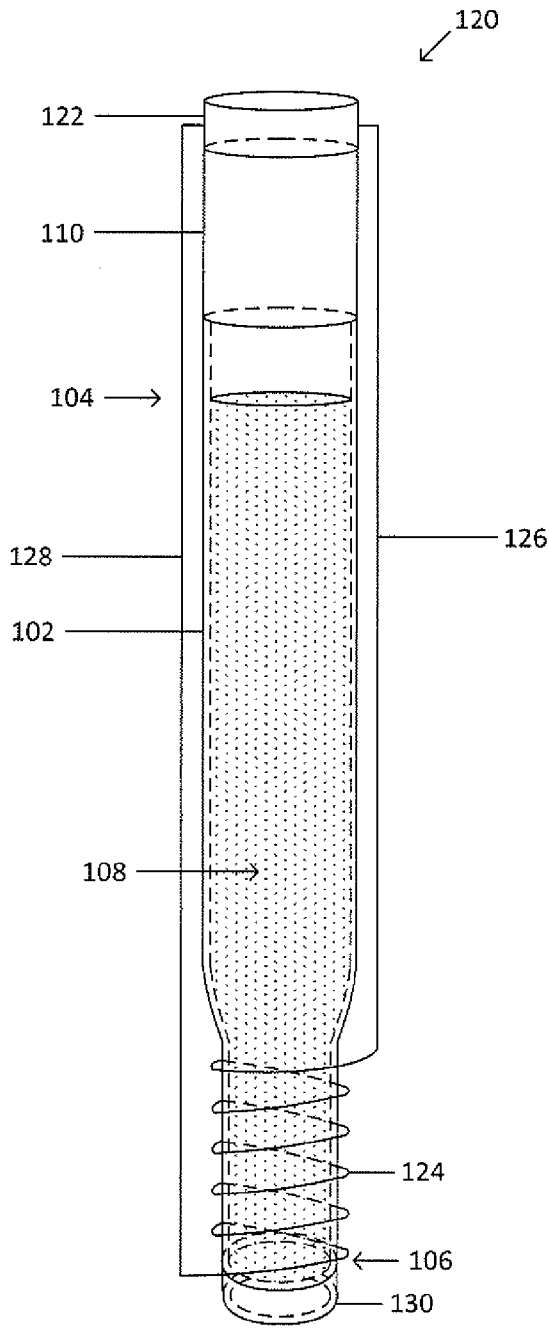

Fig. 1C

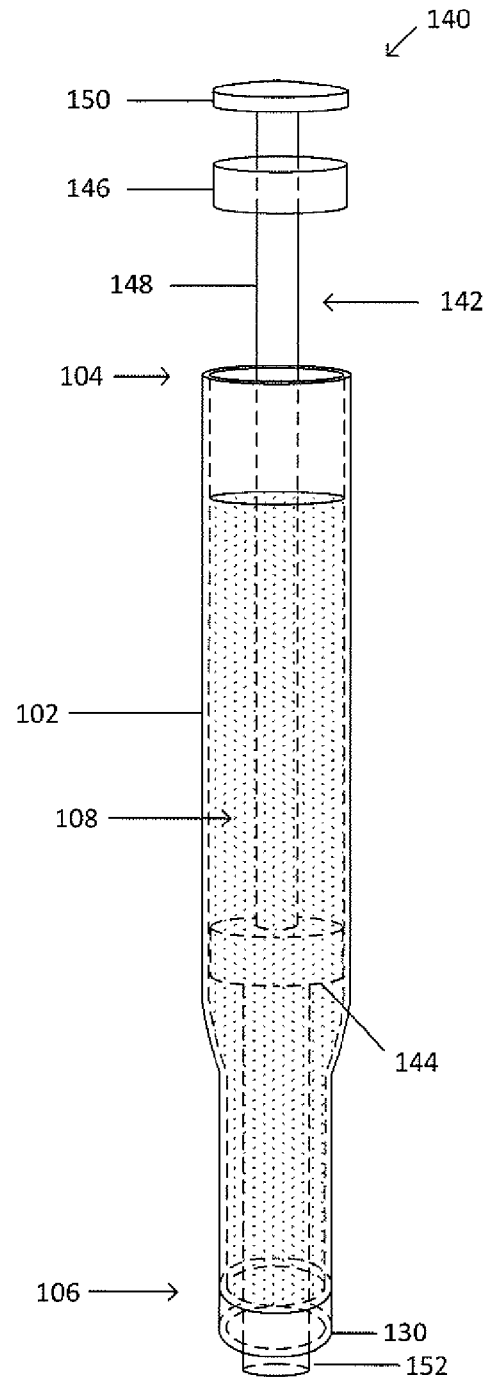

Fig. 1D

Fig. 2A

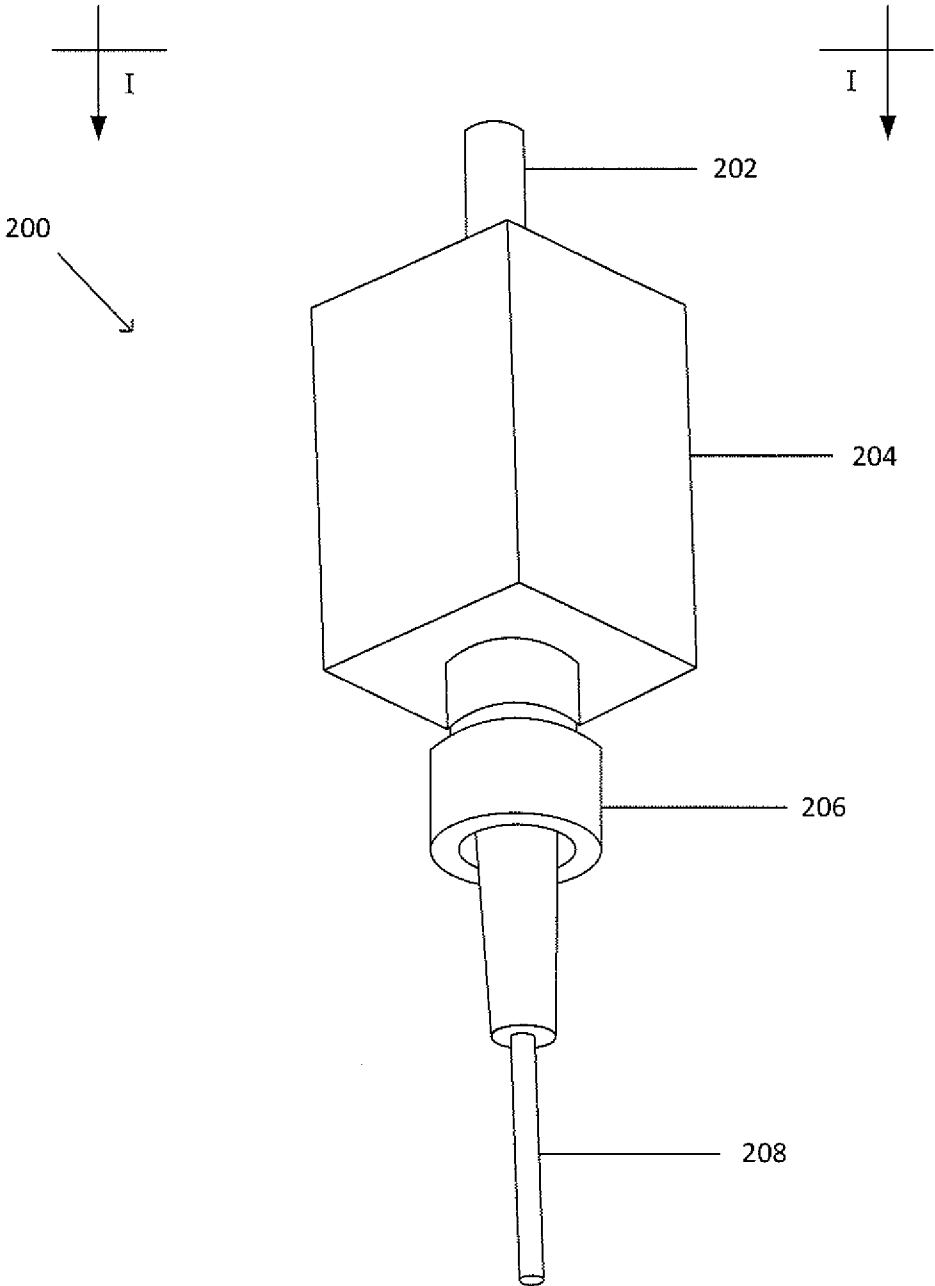

Fig. 2B

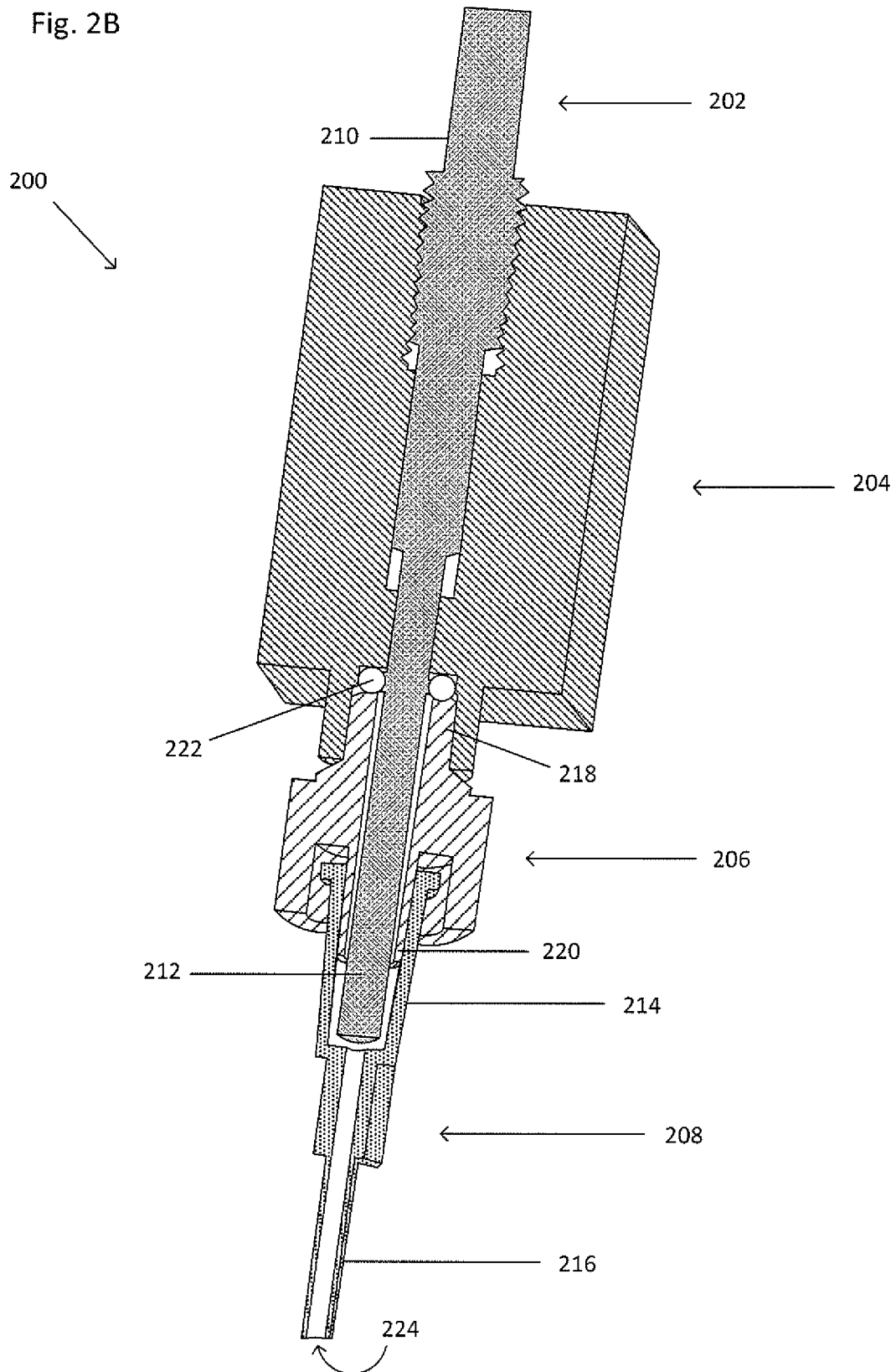

Fig. 2C

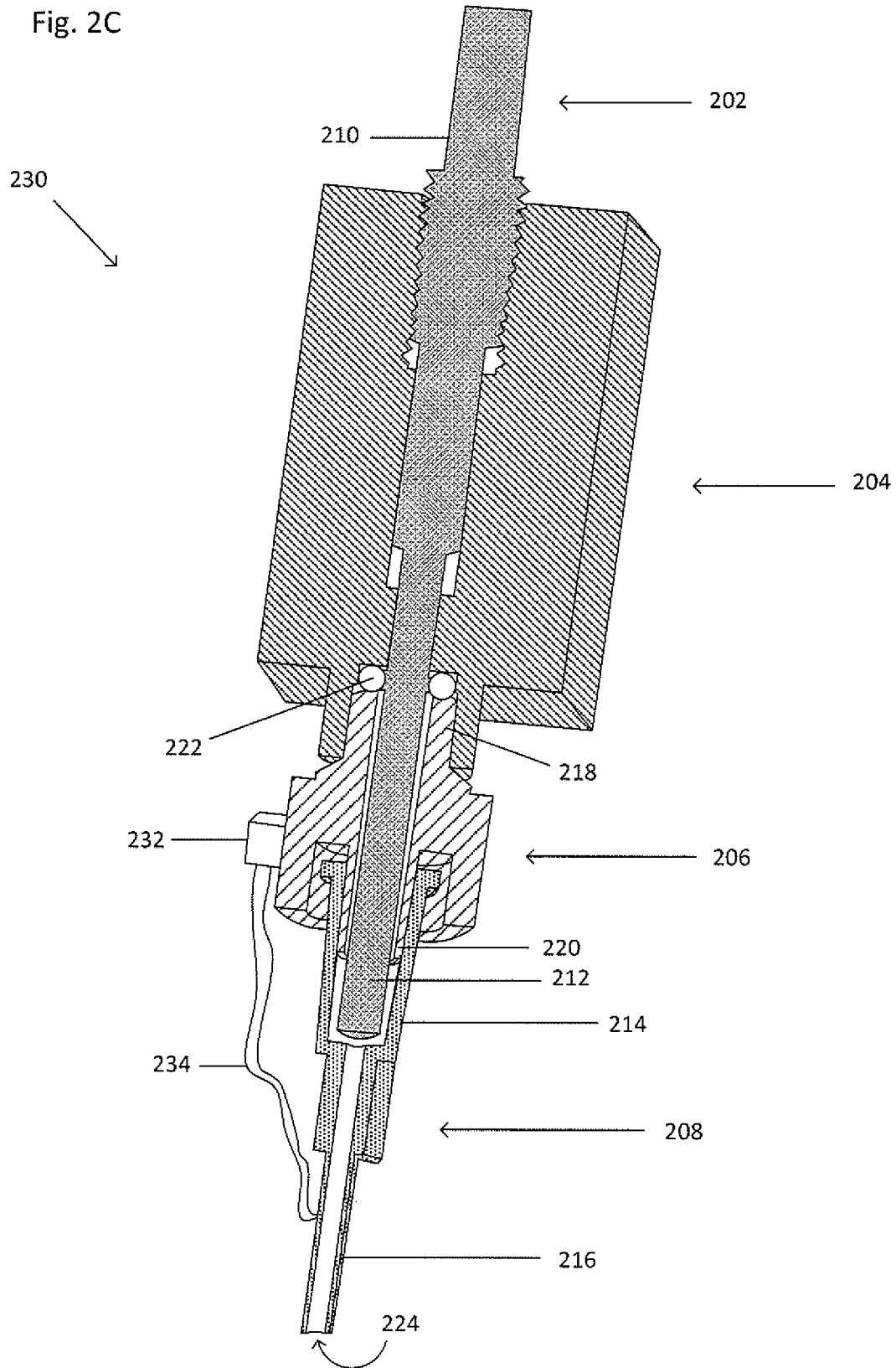

Fig. 3

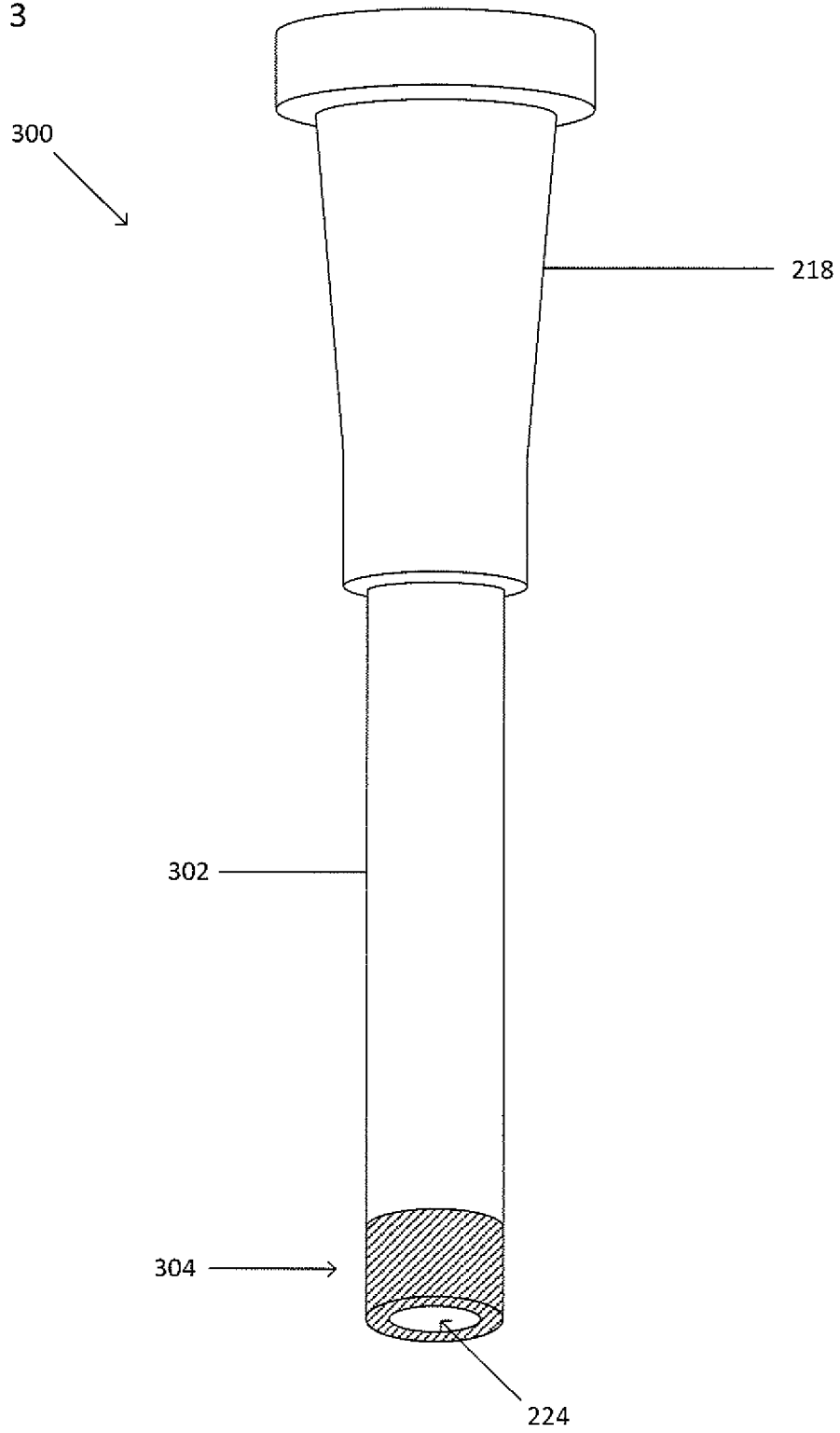

Fig. 4B

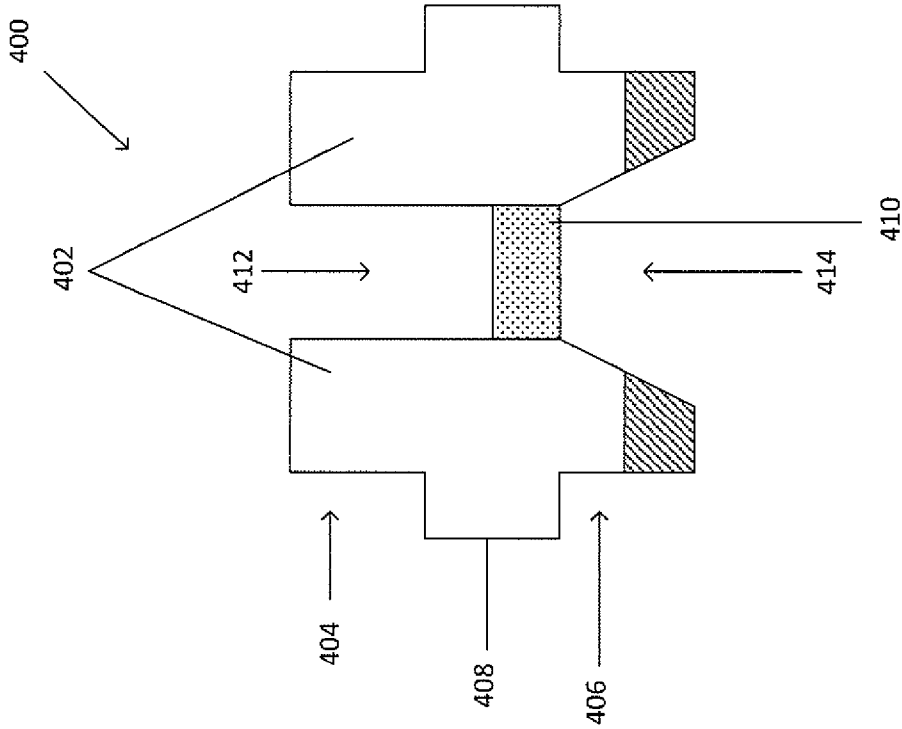

Fig. 4A

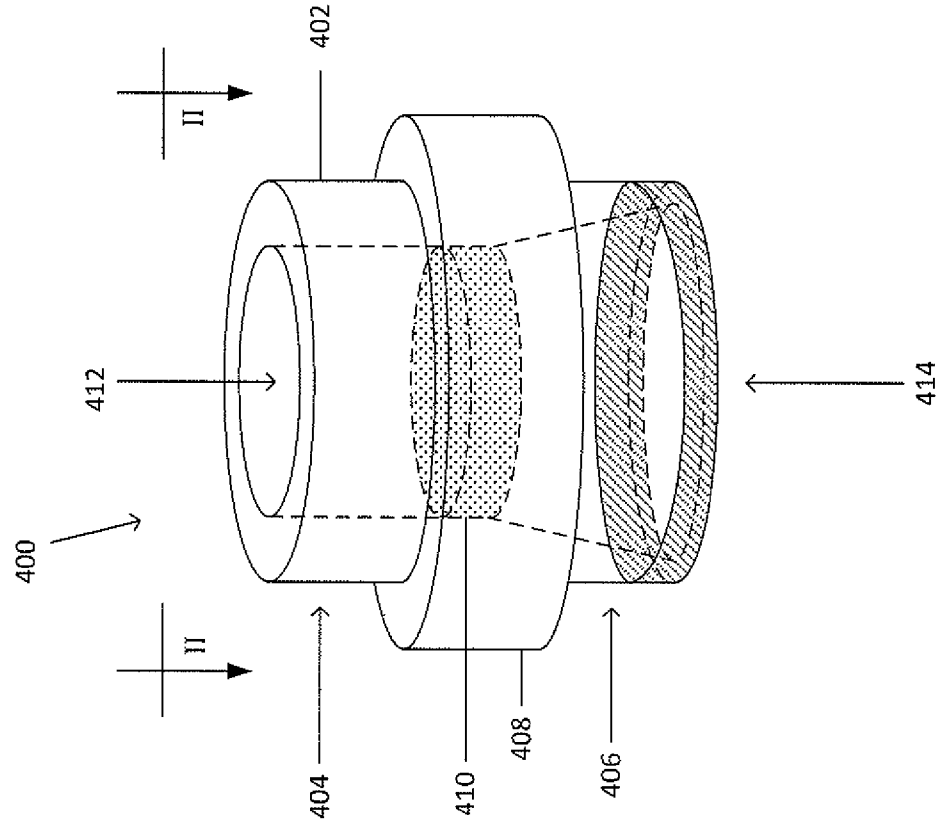

Fig. 5

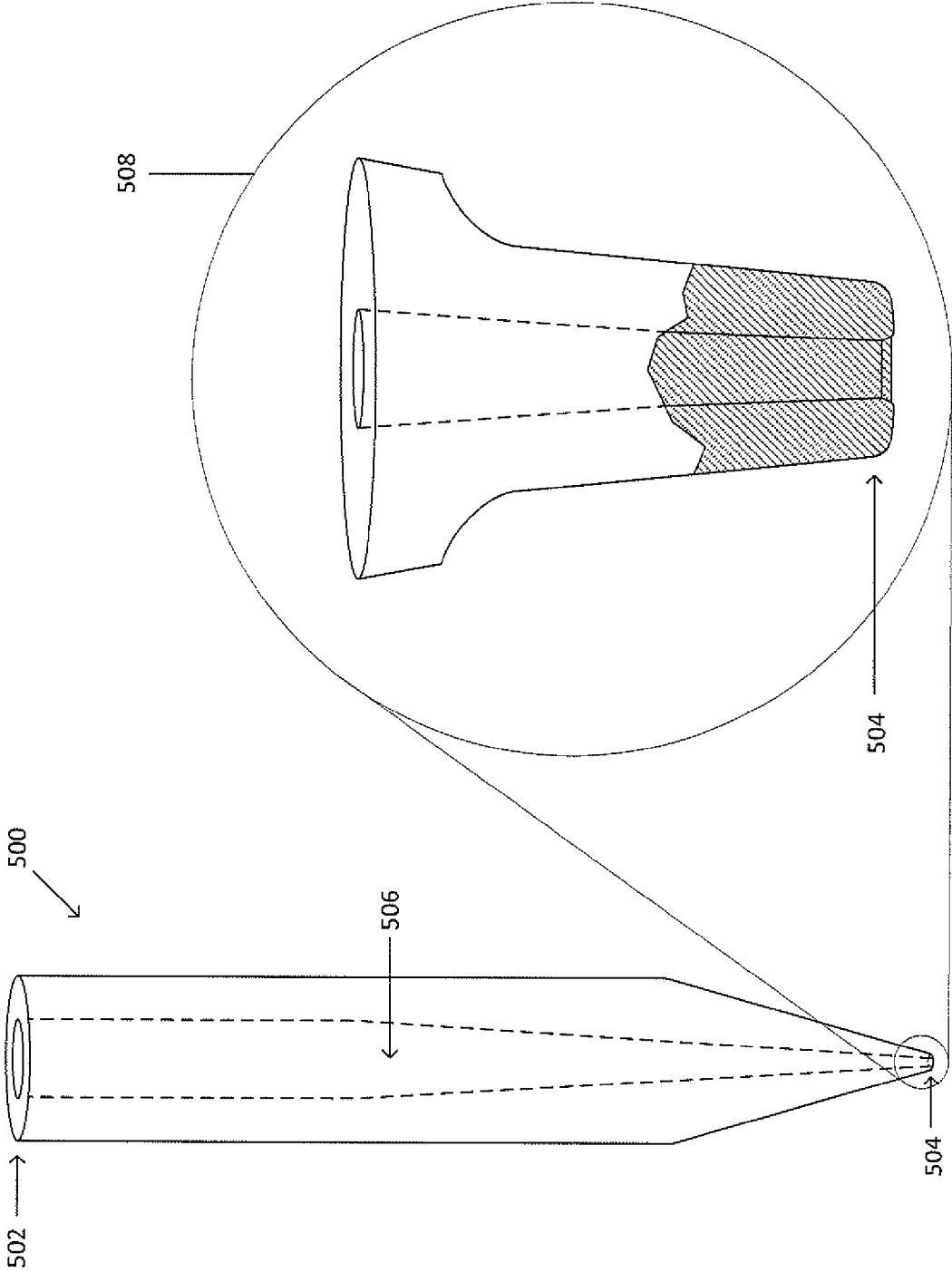

Fig. 6A

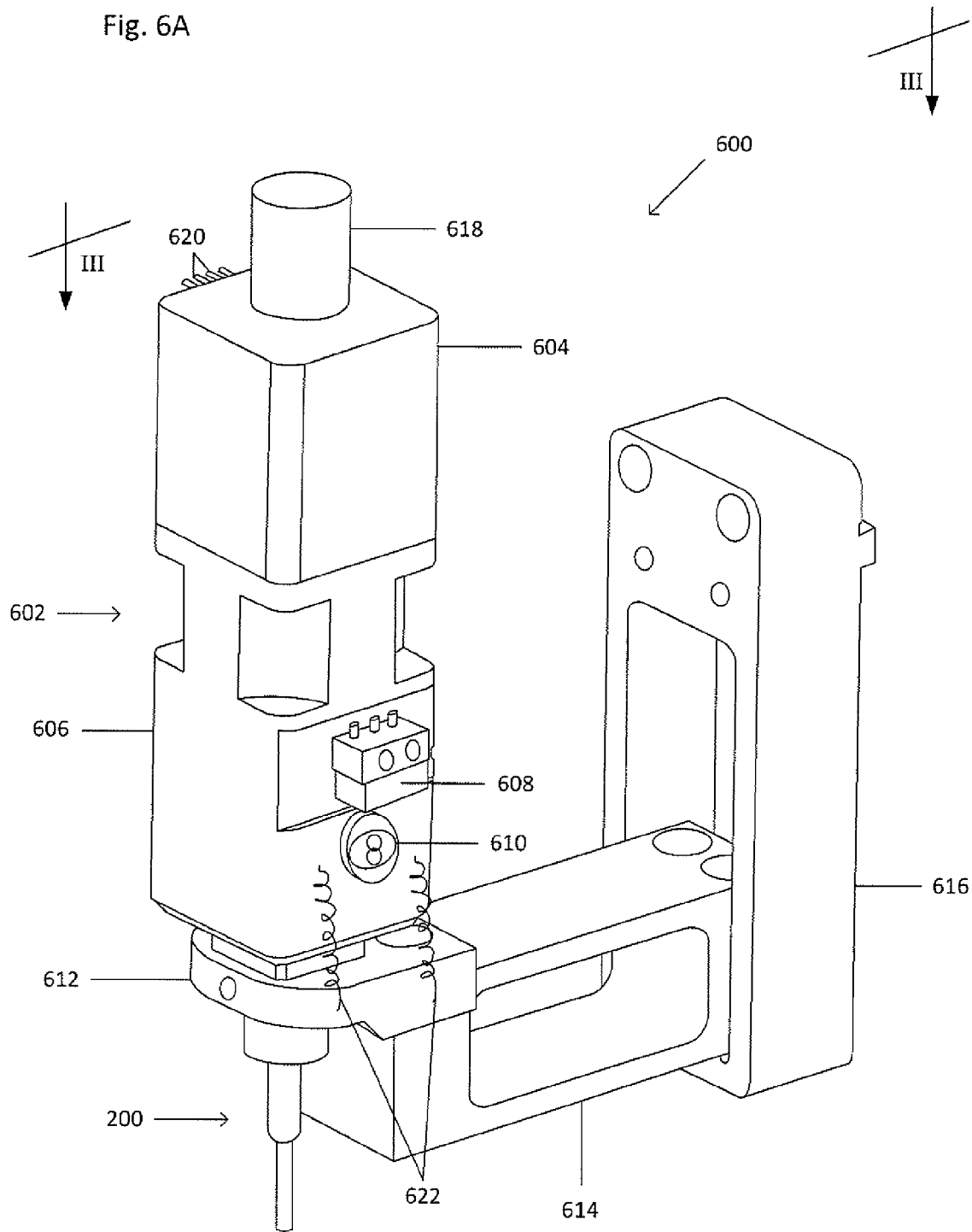
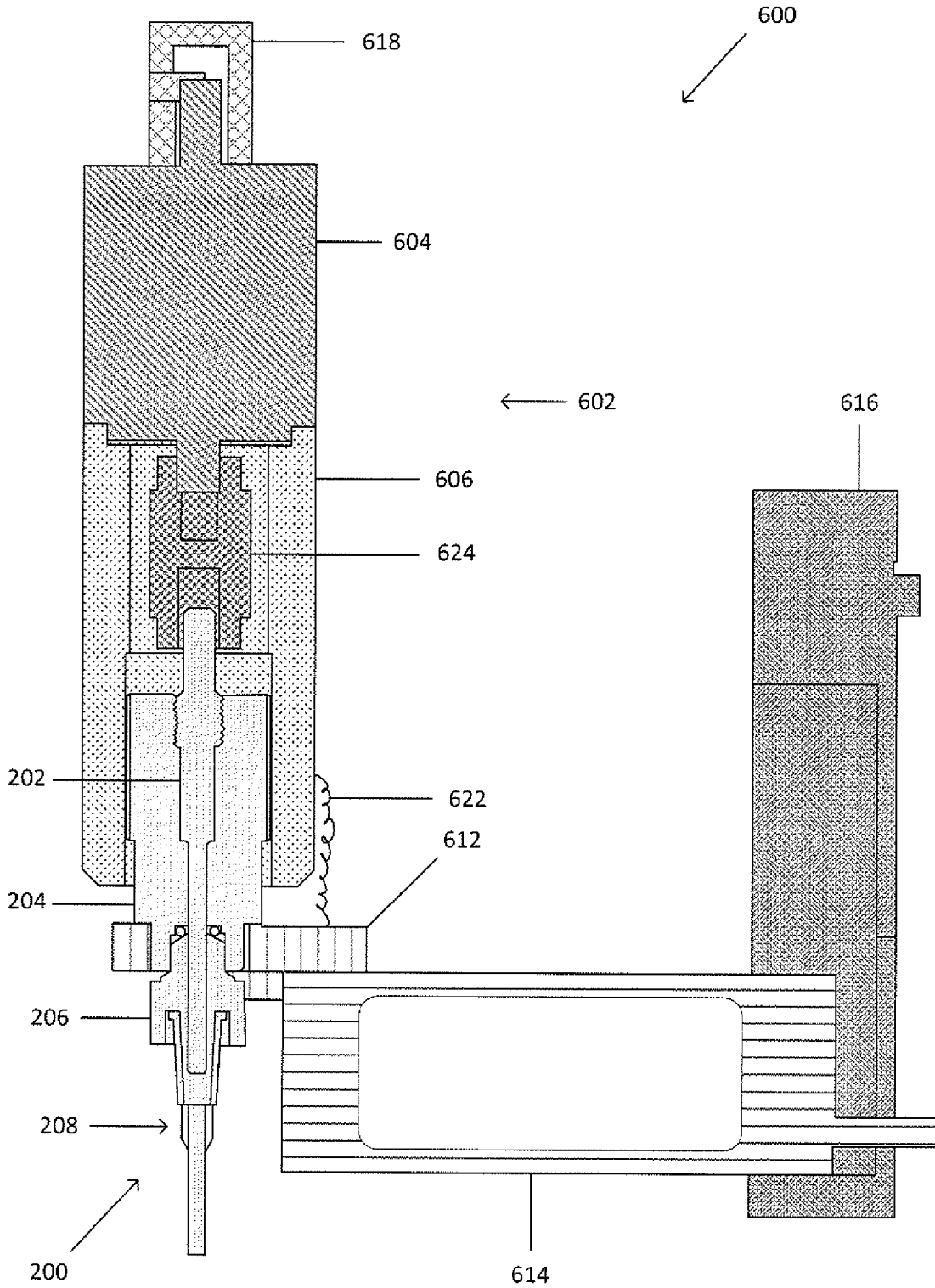

Fig. 6B



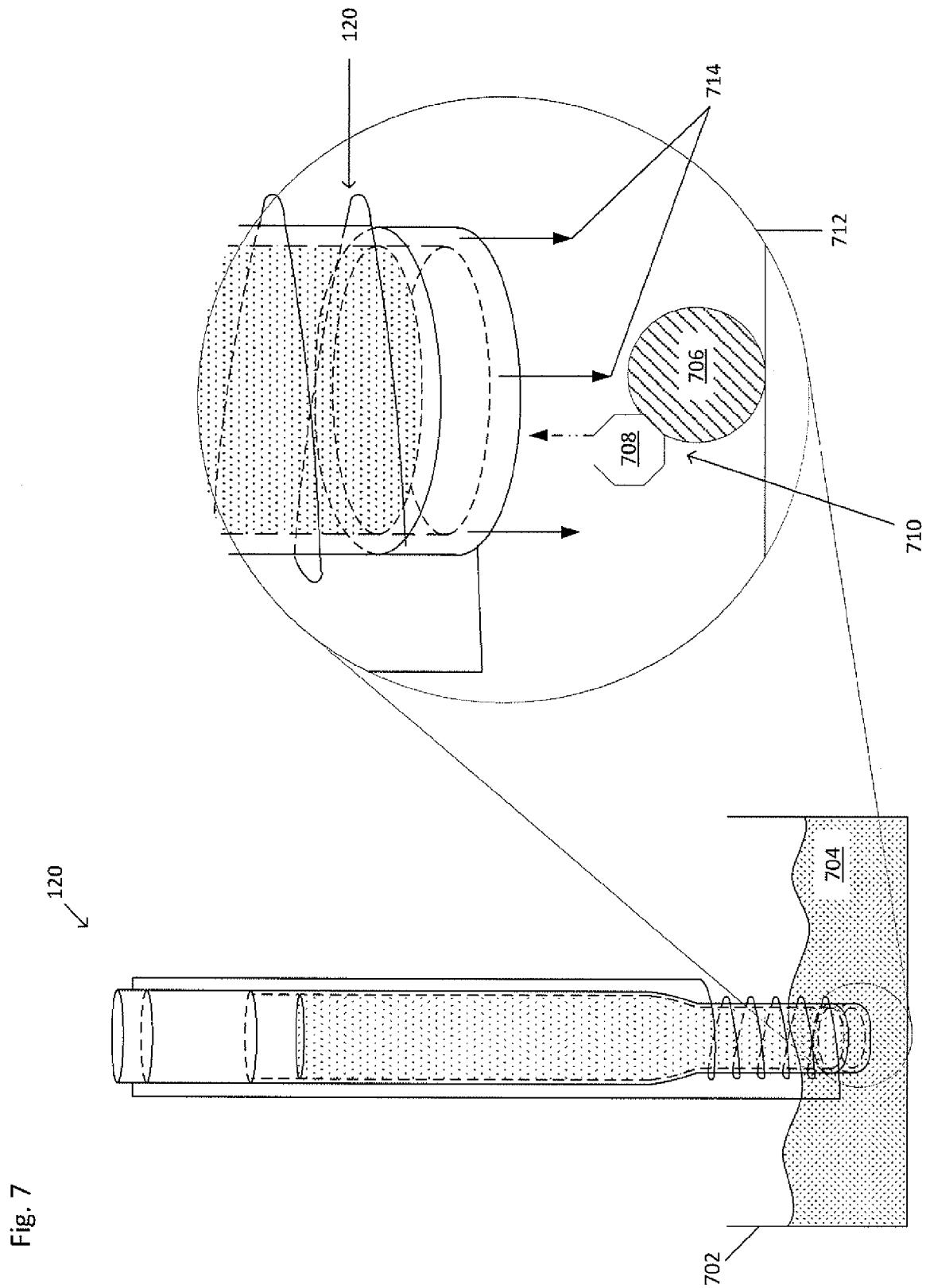

Fig. 7

1

DEVICE, SYSTEM, AND METHOD FOR SELECTING A TARGET ANALYTE

CROSS-REFERENCE TO A RELATED APPLICATION

This application claims the benefit of Provisional Application No. 61/810,834, filed Apr. 11, 2013, and Provisional Application No. 61/922,931, filed Jan. 2, 2014.

TECHNICAL FIELD

This disclosure relates generally to micromanipulation of a target analyte, though more specifically, to picking and isolating the target analyte.

BACKGROUND

Suspensions often include materials of interest that are difficult to detect, extract and isolate for analysis. For instance, whole blood is a suspension of materials in a fluid. The materials include billions of red and white blood cells and platelets in a proteinaceous fluid called plasma. Whole blood is routinely examined for the presence of abnormal organisms or cells, such as fetal cells, endothelial cells, epithelial cells, parasites, bacteria, and inflammatory cells, and viruses, including HIV, cytomegalovirus, hepatitis C virus, and Epstein-Barr virus, and nucleic acids. Currently, practitioners, researchers, and those working with blood samples try to separate, isolate, and extract certain components of a peripheral blood sample for examination. Typical techniques used to analyze a blood sample include the steps of smearing a film of blood on a slide and staining the film in a way that enables certain components to be examined by bright field microscopy.

On the other hand, materials of interest composed of particles that occur in very low numbers are especially difficult if not impossible to detect and analyze using many existing techniques. Consider, for instance, circulating tumor cells (“CTCs”), which are cancer cells that have detached from a tumor, circulate in the bloodstream, and may be regarded as seeds for subsequent growth of additional tumors (i.e., metastasis) in different tissues. The ability to accurately detect and analyze CTCs is of particular interest to oncologists and cancer researchers, but CTCs occur in very low numbers in peripheral whole blood samples. For instance, a 7.5 ml sample of peripheral whole blood that contains as few as 3 CTCs is considered clinically relevant in the diagnosis and treatment of a cancer patient. However, detecting even 1 CTC in a 7.5 ml blood sample may be clinically relevant and is equivalent to detecting 1 CTC in a background of about 50 billion red and white blood cells. Using existing techniques to find, isolate and extract as few as 3 CTCs of a whole blood sample is extremely time consuming, costly and is extremely difficult to accomplish.

As a result, practitioners, researchers, and those working with suspensions continue to seek systems and methods to more efficiently and accurately detect, isolate and extract target materials of a suspension.

DESCRIPTION OF THE DRAWINGS

FIGS. 1A-1D show examples of a picker.
FIG. 2A-2B show an example picker.
FIG. 2C shows an example picker.
FIG. 3 shows an example cannula with a fluorescent tip.
FIGS. 4A-4B show an example fluorescent picker tip.

2

FIG. 5 shows an example picker tip.
FIGS. 6A-6B show an example picking system.
FIG. 7 shows isolation of target analyte using a picker.

5

DETAILED DESCRIPTION

This disclosure is directed to a device and a system for picking a target analyte of a suspension. A picker introduces at least one force, such as by a magnetic gradient and/or by a pressure gradient, to extract the target analyte from a specimen. The magnetic gradient may be introduced by a magnet, such as a permanent magnet or an electromagnet, and the pressure gradient may be introduced by a piston which moves within a fluid-primed cannula to create the pressure gradient, thereby drawing the target analyte into the cannula. The picker may also expel the target analyte onto or into a substrate, such as a well plate, after the target analyte has been drawn into the picker by reversing the pressure gradient. A tip of the cannula may be fluorescent or may include a fluorescent insert to be visualized when extracting and/or expelling the target analyte under fluorescent microscopy. The system includes a drive assembly to drive the piston and may also include an actuator to move the picker.

General Description of Slide and Picker Systems

FIG. 1A shows an example picker **100**. The picker **100** includes a main body **102**, a back end **104**, and a tip **106**. The picker **100** may be solid or may be a hollow tube having an inner chamber for holding a liquid, target analyte, or any other appropriate material. When the picker **100** is a hollow tube, the picker **100** may also include a liquid **108** within the inner chamber of the picker **100**, where the liquid may be a solution, a buffer, a ferrofluid, or the like. The picker **100** may be used to manipulate a target analyte. The target analyte may be manipulated, such as by moving, removal, or isolation, when the specific target analyte is in a vessel, such as a tube or a well, or on a slide. The target analyte can be isolated through the introduction of a force, thereby attracting or pulling the target analyte. The tip **106** engages the target analyte for moving, removal, or isolation. The force may be created with suction or a pressure gradient, such as a vacuum. The back end **104** may be connected to a pump **110**, such as a vacuum pump, a lead screw, or a hand pump with a wheel, to aid in providing the force for moving, removal, or isolation. The picker **100** may also include a light source **112**, such as an LED, to illuminate an area in which the target analyte may be present. The light source **112** may be located anywhere along the main body **102**, including the back end **104** and the tip **106**. When the light source **112** is located at the back end **104**, the main body **102** may be composed of a material capable of propagating or transmitting a light signal produced by the light source **112**, such that the light signal exits at the tip **106** to illuminate the desired area. The light source **112** may be connected to a power supply (not shown), such as a battery, to supply current or power.

FIG. 1B shows an example picker **114**. The picker **114** is similar to the picker **100**, except that picker **114** includes a permanent magnet **116**, such as a donut-shaped magnet. The permanent magnet **116** generates a magnetic field for attracting a particle of a target analyte-particle complex, a target analyte having been previously conjugated with the particle to form the target analyte-particle complex. The picker **114** may also include a magnetizable material to extend or transmit the magnetic field produced by the magnet. The

permanent magnet **116** may be located at the tip **106** or at or near the back end **104**. The permanent magnet **116** may be removable. Alternatively, the fluid, such as a ferrofluid, within the picker **114** may be used to generate the magnetic field or magnetic gradient.

FIG. 1C shows an example picker **120**. The picker **120** is similar to the picker **100**, except that picker **120** includes an electromagnet. The electromagnet includes a power source **122**, a first lead **126**, a second lead **128**, and a coil **124**. The power source **122** may be, but is not limited to, a battery, a DC supply, or an AC supply. The electromagnet generates a magnetic field for attracting a particle of a target analyte-particle complex, a target analyte having been previously conjugated with the particle to form the target analyte-particle complex. The picker **120** may be composed of a magnetizable material to extend or transmit the magnetic field produced by the magnet. The first lead **126**, the second **128**, and the coil **124** may be located outside of a wall of the picker **120**, may be embedded with the wall of the picker **120**, or may be located inside of the picker **120**. The picker **120** may also include a light source **130**, such as an LED, to illuminate an area in which the target analyte may be present. The light source **130** may be located anywhere along the main body **102**, including the back end **104** and the tip **106**. When the light source **130** is located at the back end **104**, the main body **102** may be composed of a material capable of propagating or transmitting a light signal produced by the light source **130**, such that the light signal exits at the tip **106** to illuminate the desired area. The light source **130** may be connected to a power supply (not shown), such as a battery, to supply current or power.

FIG. 1D shows an example picker **140**. The picker **140** includes a retractable shaft **142**, the retractable shaft **142** being thinner than the main body **102** and being extendable from the tip **106**. The retractable shaft **142** can be located within the main body **102**, can be extended out of the tip **106** to engage a target analyte, and can be retracted into the main body **102**. When the target analyte attaches to the retractable shaft **142**, the target analyte can be drawn into the main body **102**. The retractable shaft **142** may include an engagement portion **152**, a stopper **144**, a grip **150**, and a rod **148**. The engagement portion **152** may be extended out of the tip **106** to engage the target analyte. The stopper **144** may be sized to fit within the main body **102**, but be larger than the tip **106** or a taper from the main body **102** to the tip **106**, thereby preventing the retractable shaft **142** from extending too far from the tip **106**. The grip **150** may allow for engagement of the retractable shaft **142**, so as to properly move the retractable shaft **142**. The rod **148** may connect the stopper **144** or the engagement portion **146** to the grip **140**. The retractable shaft **142** may also be made magnetizable by including a magnet **146** disposed on or within the retractable shaft **142**. The magnetic field or magnetic gradient may be removed or deactivated, such as by removing the magnet **146** or turning off an electromagnet. The target analyte-particle complex is no longer attracted and held to the retractable shaft **142** causing the target analyte-particle complex to remain within the liquid in the main body **102**. The picker **140** may also include a light source **130**, such as an LED, to illuminate an area in which the target analyte may be present. The light source **130** may be located anywhere along the main body **102**, including the back end **104** and the tip **106**. When the light source **130** is located at the back end **104**, the main body **102** may be composed of a material capable of propagating or transmitting a light signal produced by the light source **130**, such that the light signal exits at the tip **106**

to illuminate the desired area. The light source **130** may be connected to a power supply (not shown), such as a battery, to supply current or power.

Alternatively, the retractable shaft **142** may be magnetized by an electromagnet, such as a coil wrapped around a segment of or the entire retractable shaft **142**. Alternatively, the picker **140** may include a pump (not shown), such as a vacuum pump, a lead screw, or a hand pump with a wheel, to aid in providing the force for moving, removal, or isolation.

FIG. 2A shows an example picker **200**. FIG. 2B shows a cross-sectional view of the example picker **200** taken along the line I-I. The picker **200** includes a piston **202**, a pump block **204**, and a cannula **208**. The picker **200** may also include a fitting **206** with a first side **218** and a second side **220**. The piston **202** includes a first end **210** and a second end **212**. The cannula **208** includes an adapter **214** and a tube end **216**, the tube end **216** including an opening **224**. The first side **218** of the fitting **206** mates with the pump block **204**, such as by a press-fit, detents, notches, complementary threads, or the like. A seal **222** may be formed between the first side **218** of the fitting **206** or the adapter **214** of the cannula **208** and the pump block **204**, such as by an O-ring or silicone grease, to close the picker **200**. The adapter **214** of the cannula **208** may mate with the second side **220** of the fitting **206** or a side of the pump block **204**, such as by a press-fit, detents, notches, complementary threads, or the like.

The piston **202** may be any appropriate length. The second end **212** of the piston **202** may be located within the pump block **204**, within the fitting **206**, or may extend through the pump block **204** and into the adapter **214** of the cannula or past the adapter **214** of the cannula **208** and into the tube end **216** of the cannula. The first end **210** of the piston **202** may be located within the pump block **204** or extend out of a side of the pump block **204** opposite a side of the pump block **204** that connects to the adapter **214**. The piston **202** and the cannula **208** may substantially share a central axis. The positioning of the piston **202** relative to the cannula **208** reduces or eliminates dead volume. Alternatively, the cannula **208**, without the inclusion of the fitting **206**, may be connected directly to the pump block **204**. The adapter **214** may be connected to the first end of the pump block **204**.

The pump block **204** at least partially houses the piston **202** and allows for translation of the piston **202** relative to the pump block **204**. The piston **202**, such as a lead screw or rod, translates within the pump block **204** to create a pressure differential at the tube end **216** of the cannula **208** so as to draw a target analyte into or expel the target analyte from the tube end **216** of the cannula **208**. Moving the piston **202** upwards within the pump block **204** may create a negative pressure at the tube end **216** so as to draw a target analyte from the suspension into the cannula **208** or may create a positive pressure to expel a target analyte located within the cannula **208** from the tube end **216**. The piston **202** may be connected to a motor or an actuator to drive the piston **202** up and down, thereby creating the desired pressure differential. The pump block **204** may include a complementary mating feature, such as threads or a bore, to accept and mate with the piston **202**. When the piston **202** and the pump block **204** include complementary threads, the piston **202** may be rotated to cause the desired translation. A full rotation of the piston **202** may include any number of steps, including 1-10,000 steps. Those steps may then include any number of micro-steps, including 1-10,000 micro-steps. Each step or micro-step may draw in a volume

5

approximately equal to or less than 1 picoliter, 10 picoliters, 100 picoliters, 1 nanoliter, 1 microliter, or 1 milliliter.

The cannula 208 may be primed with a fluid, such as a solution, an oil, a liquid metal, a buffer, or the like. Priming the picker 200 with the fluid provides better control than a picker that is not primed (i.e. filled with air). The air in a non-primed picker provides more disconnect between the piston 202 and a sample or the target analyte because of the greater compressibility of the air relative to the fluid. The greater compressibility leads to greater lag or delay, thereby providing less control and/or volume resolution. Furthermore, the opening 224 may be less than or equal to 1 micrometer or less than or equal to 1 millimeter.

The picker 200 may introduce a magnetic gradient as well, such as by a permanent magnet or an electromagnet, as shown in FIGS. 1B and 1C, respectively, whereby the cannula 208, the priming fluid, or a tip is magnetizable so as to propagate the magnetic gradient. The permanent magnet may be located along the tube end of the cannula, on the piston, or anywhere on the picker tip. When a ferrofluid primes the cannula, the permanent magnet may be located near the adapter. The electromagnet includes a coil, a first lead, a second lead, and a power supply, such as a battery. The coil wraps around the tube end of the cannula or the picker tip. A first end of the first lead is connected to the power supply and a second end of the first lead is connected to a first end of the coil. A first end of the second lead is connected to the power supply and a second end of the second lead is connected to a second end of the coil. The power supply is disposed outside of the pump block.

FIG. 2C shows a picker 230. The picker 230 is similar to the picker 200 except that the picker 230 includes a light source 232. The light source 232 produces a light signal that is propagated or transmitted by the cannula 208 or picker tip inserted into the cannula 208. The cannula 208 or the picker tip may be composed of a material capable of propagating or transmitting the light signal produced by the light source 232, such that the light signal exits at the tube end 216 of the cannula 208 or the end of the picker tip furthest away from the pump block 204 to illuminate the desired area and/or stimulate a fluorescent probe bound to a target analyte. When the light source 232, such as an LED, originates at a location other than the tube end 216 of the cannula 208 or the end of the picker tip furthest away from the pump block 204, a cable 234, such as a fiber optic cable, may transmit the light signal to the tube end 216 of the cannula 208 or the end of the picker tip furthest away from the pump block 204 for illumination and/or stimulation purposes. The light source 232 may provide oblique illumination. The light source 232 may be connected to a power supply (not shown), such as a battery, to supply current or power. Alternatively, the light source 232 may be between the top of the adapter of the cannula 208 and the fitting 206. Alternatively, at least one light source may be embedded in the tube end of the cannula 208. Alternatively, the light source 232 may be located on the adapter 214 or the pump block 204.

FIG. 3 shows a cannula 300. The cannula 300 is similar to the cannula 208, except that a tube end 302 of the cannula 300 includes a fluorescent tip 304. The fluorescent tip 304 emits light in a particular wavelength when excited or stimulated by a stimulus, such as light with a first wavelength. The fluorescent tip 304 may be used to emit light that improves visualization of the cannula 300 for better placement over the desired target analyte during collection. Alternatively, the entire tube end 302 of the cannula 300 may be composed of a fluorescent material.

6

FIG. 4A shows a picker tip 400. FIG. 4B shows a cross-sectional view of the picker tip 400 taken along the line II-II. The picker tip 400 may be inserted into the tube end 216 of the cannula 208. The picker tip 400 includes a main body 402 and a permeable membrane 410. The main body 402 includes a first end 404 with a first bore 412 having a first diameter and a second end 406 with a tapered bore 414 having a second diameter which tapers to the same diameter as the first diameter of the first bore 412. The second end 406 may be entirely fluorescent or a portion thereof may be fluorescent, or the second end 406 may not be fluorescent. The second diameter may be larger or smaller than the first diameter. Furthermore, the widest part of the tapered bore 414 may be less than or equal to 1 micrometer or less than or equal to 1 millimeter.

The first end 404 is inserted within the tube end 216 of the cannula 208. The permeable membrane 410 may be located within the first bore 412 or the second bore 414 and is composed of a material including at least one pore. The permeable membrane 410 permits the target analyte to be drawn a distance into the picker. The picker tip 400 may also include a ridge 408 extending circumferentially from the main body 402 to prevent the picker tip 400 from translating further into the tube end 216 of the cannula 208.

FIG. 5 shows a picker tip 500. The picker tip 500 may be inserted into the tube end 216 of the cannula 208. The picker tip 500 includes a first end 502, a second end 504, and a central bore 506. The first end 502 is the portion of the picker tip 500 to be inserted into the tube end 216 of the cannula 208. The picker tip 500 may be straight, tapered, or a combination thereof. The central bore 506 extends from the first end 502 to the second end 504 and may be straight, tapered, or a combination thereof. Furthermore, the portion of the central bore 506 at the second end 504 may be less than or equal to 1 micrometer or less than or equal to 1 millimeter.

Magnified view 508 shows the second end 504 with an outer segment removed to reveal the inner configuration of the second end 504. The second end 504 may be flat or angled. The second end 504 may also include a counter-sink, as shown in FIG. 5.

FIG. 6A shows picking system 600 including a drive assembly 602, the picker 200 as shown in FIGS. 2A-2B, and an actuator 614. FIG. 6B shows a cross-sectional view of the picking system 600. The drive assembly 602 includes a driver 604 including a first end and second end, a coupling 624 including a first end and a second end, and a housing 606. The first end of the coupling 624 mates with the second end of the driver 604, and the second end of the coupling 624 mates with the piston 202. When the second end of the driver 604 rotates, the coupling 624 rotates, thereby causing the piston 202 to rotate and translate within the pump block 204, the fitting 206, and the cannula 208. Alternatively, the second end of the driver 604 translates along a central axis, the coupling 624 translates along the central axis, thereby causing the piston 202 to translate within the pump block 204, the fitting 206, and the cannula 208.

The housing 606 is a piece which encases and protects at least the second end of the driver 604, the coupling 624, the first end 210 of the piston 202, and at least a portion of the pump block 204. The housing 606 may inhibit rotation of the driver 604 relative to the pump block 204. The housing 606 also supports the driver 604. The housing 606 may be fixedly attached to the driver 604. The housing 606 may include a travel slot (not shown) and a screw 610, such as a shoulder screw, to set the maximum permissible travel of the pump block 204 relative to the housing 604. The screw 610 is

inserted through the travel slot (not shown) and screwed into a threaded hole on a side of the pump block 204. Alternatively, the screw 610 may be inserted through the travel slot (not shown) and compressed against a side of the pump block 204.

At least one side of the pump block 204 may be biased against at least one side of the housing 606 to inhibit rotational motion between the pump block 204 and the housing 606 so as to reduce or eliminate backlash. For example, a spring (not shown) may be placed between the pump block 204 and the housing 606 below the screw head of the screw 610.

The driver 604 may be a motor, such as a servomotor or a stepper motor, a piezo-electric actuator, a solenoid, or the like. The driver 604 provides high resolution control of the picker 200. The coupling 624 provides zero backlash and may be axially stiff and torsionally stiff. For example, the coupling 624 may be a non-expanding bellows or split-beam drive assembly, or the like.

The housing 606, by supporting the driver 604 and only encasing a portion of the driver 604, may reduce or eliminate expansion of the picker 200 that may result from the heat generated by the driver 604. Decoupling or separating the picker 200 and the driver 604 may reduce or eliminate expansion of the components of the picker 100. Furthermore, the weight of the driver 604 and external constraints 622, such as springs or weights, bias and preload the threads of the piston 202 to reduce or eliminate change or backlash. When the external constraints 622 are springs, the springs may extend from the housing 606 to a base 612. When the external constraints 622 are weights, the weights may be placed on top of the driver 604 or the housing 606.

The drive assembly 602 may also include a home switch 608 to return the picker 200 to the home or original position. The drive assembly 602 may also include a driver knob 618 for manual operation and/or wire leads 620 for automated operation. Manual operation may include adjustments or movements to the picker or picking system by hand or may include motorized adjustments or movements to the picker or picking by an operator via a manual controller, such as a touch screen, a joystick, a directional pad or the like.

The picking system 600 also includes the actuator 614, such as a piezo-electric actuator, a lead screw, or a stage. The actuator 614 may be connected to the picker 200, such as by the base 612, or may be connected to the drive assembly 602. The base 612 supports the picker 200 and may connect the actuator 614 to the picker 200. The base 612 may include a light source (not shown), such as a LED, to provide oblique illumination of the picker tip or tube end of the cannula.

The actuator 614 provides high resolution location control of the picker 200, has a rapid response (for example, to allow for oscillation), and may be operated in an open or closed loop. The actuator 614 may provide motion along the x, y, and z axes or may provide motion along only one axis. The actuator 614 may have a travel range of 1 nanometer to more than 50 millimeters along each axis. The lower end of the travel range permits the actuator 614 to make finer adjustments (approximately 0.001-500 μm) for the picker 200 so as to better locate and pick a target analyte. The upper end of the travel range permits the actuator to make coarser adjustments (approximately 10-50 mm) for the picker 200, such as to move the picker to different wells to draw up or expel different fluids from the different wells or receptacles, to change cannulas or replace parts when it is desirable to do so. The cannula or picker tip, for example, may be replaced by manual operation (i.e. changing out by hand) or by

automated operation (i.e. by expelling the used cannula or picker tip, moving the picker over a cartridge containing at least one new cannula or picker tip, lowering the picker to mate with the new cannula or picker tip, raising the picker, and returning to a desired position). When the actuator 614 provides motion along only one axis, a second actuator (not shown) may be used to provide motion along all three axes. Furthermore, when the actuator 614 provides motion along only one axis, the second actuator (not shown) may be used for coarser adjustments, whereas the actuator 614 may be used for finer adjustments.

The picking system 600 may also include a mount 616 to attach the picker 200, the drive assembly 602, and the actuator 614 to an imaging or detection system, such as a scanner or a microscope. The mount 616 may be stationary within the imaging or detection system or may be attached to the second actuator (not shown) within the imaging or detection system.

The picker can be composed of a variety of different materials including, but not limited to, ceramics; glass; metals; organic or inorganic materials; plastic materials; and combinations thereof. The picker tip can also be composed of a variety of different materials including, but not limited to, ceramics; glass; metals; organic or inorganic materials; plastic materials; and combinations thereof. Furthermore, the cannula or the picker tip may be composed of a material that is fluorescent. Additionally, the tube end of the cannula or the picker tip may be impact-resistant, hard, and dimensionally stable (i.e. axially and/or torsionally stiff).

The permanent magnet includes, but is not limited to, a ring magnet, a bar magnet, a horseshoe magnet, a donut-shaped magnet, a spherical magnet, a polygon-shaped magnet, a polyhedral shape, a wand magnet, a kidney-shaped magnet, a trapezoidal magnet, a disk magnet, a cow magnet, a block or brick magnet, or combinations thereof. The magnetizable material includes, but is not limited to, metals, organic materials, inorganic materials, minerals, ferrofluids, and combinations thereof.

The cannula, tip and engagement portion may be stiff, flexible or formable. The cannula, tip and engagement portion may be straight, angled, curved, hooked, or any appropriate shape or configuration. The cannula, tip, and engagement portion may be non-clogging.

Methods for Using a Picker

A picker may be used to isolate a target analyte from a suspension. For example, FIG. 7 shows the picker 120 isolating a target analyte 706 from a suspension 704. A solution containing a particle 708 to conjugate with the target analyte 706 to form a target analyte-particle complex 710 may be added to the suspension 704. The target analyte-particle complex 710, including the particle 708 and the target analyte 706, being attracted by a magnetic field introduced by the picker 120, moves upwards within a vessel 702. The particle 708 which is bound to the target analyte 706 causes the target analyte 706 to move upwards toward the picker 120. The target analyte 706 may then be held, via the particle 708 to which the target analyte 706 is bound, to the picker 120 due to the magnetic field. Alternatively, the target analyte-particle complex 210 may be attracted to the picker 120 via the magnetic force and then sucked into the picker 120 via a suction device on the picker 120.

The particle may come in any form, including, but not limited to, a bead, a nanoparticle (such as a quantum dot), a shaving, a filing, or the like, such that the particle is capable of being attracted by a magnetic field or magnetic gradient

introduced by a magnet. The particle may itself be magnetic, diamagnetic, ferromagnetic, or paramagnetic.

The picker may be used in conjunction with a vessel 702, such as a well, a well plate, a slide, or the like. For example, to isolate the target analyte 706, the suspension 704 suspected of containing the target analyte 706 can be placed in the vessel 702. Alternatively, a fraction of the suspension 704, the fraction suspected of containing the target analyte 706, can be placed in the vessel 702. The vessel 702 may be imaged to detect the target analyte 706 and determine the location of the target analyte 706. After determining the location of the target analyte 706, the target analyte 706 may be manipulated and/or isolated by the introduction of a force to draw the target analyte 706 to or into a picker, such as a manipulator 120. The picker 120 can be brought into close proximity to the specific target analyte. The force produced by the picker 120 attracts, moves, or holds specific target analyte, so that the target analyte may be manipulated as desired. For example, the picker 120 produces the force by electromagnetism. When a suction or vacuum force is used, the target analyte 706 may be pulled out of the vessel 702. The solid arrows 714 show the light signal produced by the light source 130 illuminating the area in which the target analyte 706 is located.

To remove the target analyte from a wet mount or a suspension, a pressure gradient may be introduced by the picker 200 after the cannula 208 is placed near, over, or above the target analyte. The pressure gradient causes the target analyte to move into the cannula 208. To remove the target analyte from a dry mount (i.e. a dry slide), the cannula 208 is placed over the target analyte. The cannula 208 may then be moved horizontally or orthogonally to detach the target analyte from the mount. The pressure gradient may then be introduced to draw the target analyte into the cannula 208. Alternatively, the cannula 208, after being placed over the target analyte, may oscillate up and down at any appropriate frequency to detach the target analyte from the mount, such as, for example, less than or equal to approximately 10 kHz. The pressure gradient may then be introduced to draw the target analyte into the cannula 208. Alternatively, the cannula 208 may be placed over the target analyte and the target analyte may be held within the cannula without actively applying the pressure gradient. Alternatively, the cannula 208 may be placed over the target analyte and dragged across the surface of the slide, thereby dislodging the target analyte and causing the target analyte to be held within the cannula without actively applying the pressure gradient. Alternatively, the permanent magnet or electromagnet may be engaged and/or activated so as to remove a target analyte bound to a magnetic particle.

The target analyte may be collected, and once collected, the target analyte may be analyzed using any appropriate analysis method or technique, though more specifically intracellular analysis including intracellular or extracellular protein labeling; nucleic acid analysis, including, but not limited to, protein or nucleic acid microarrays; FISH; or bDNA analysis. These techniques require isolation, permeabilization, and fixation of the target analyte prior to analysis. Some of the intracellular proteins which may be labeled include, but are not limited to, cytokeratin ("CK"), actin, Arp2/3, coronin, dystrophin, FtsZ, myosin, spectrin, tubulin, collagen, cathepsin D, ALDH, PBGD, Akt1, Akt2, c-myc, caspases, survivin, p27^{kip}, FOXC2, BRAF, Phospho-Akt1 and 2, Phospho-Erk1/2, Erk1/2, P38 MAPK, Vimentin, ER, PgR, PI3K, pFAK, KRAS, ALKH1, Twist1, Snail1, ZEB1, Slug, Ki-67, M30, MAGEA3, phosphorylated receptor kinases, modified histones, chromatin-associated proteins,

and MAGE. In order to fix, permeabilize, or label, fixing agents (such as formaldehyde, formalin, methanol, acetone, paraformaldehyde, or glutaraldehyde), detergents (such as saponin, polyoxyethylene, digitonin, octyl β -glucoside, octyl β -thioglucoside, 1-S-octyl- β -D-thioglucopyranoside, polysorbate-20, CHAPS, CHAPSO, (1,1,3,3-Tetramethylbutyl)phenyl-polyethylene glycol or octylphenol ethylene oxide), or labeling agents (such as fluorescently-labeled antibodies, Pap stain, Giemsa stain, or hematoxylin and eosin stain) may be used.

It should be understood that the method and system described and discussed herein may be used with any appropriate suspension or biological sample, such as blood, bone marrow, cystic fluid, ascites fluid, stool, semen, cerebrospinal fluid, nipple aspirate fluid, saliva, amniotic fluid, vaginal secretions, mucus membrane secretions, aqueous humor, vitreous humor, vomit, and any other physiological fluid or semi-solid. It should also be understood that a target analyte can be a cell, such as ova or a circulating tumor cell ("CTC"), a nucleated red blood cell, a fetal cell, a circulating endothelial cell, a vesicle, a liposome, a protein, a nucleic acid, a biological molecule, a naturally occurring or artificially prepared microscopic unit having an enclosed membrane, a parasite, a microorganism, or an inflammatory cell.

The foregoing description, for purposes of explanation, used specific nomenclature to provide a thorough understanding of the disclosure. However, it will be apparent to one skilled in the art that the specific details are not required in order to practice the systems and methods described herein. The foregoing descriptions of specific embodiments are presented by way of examples for purposes of illustration and description. They are not intended to be exhaustive of or to limit this disclosure to the precise forms described. Many modifications and variations are possible in view of the above teachings. The embodiments are shown and described in order to best explain the principles of this disclosure and practical applications, to thereby enable others skilled in the art to best utilize this disclosure and various embodiments with various modifications as are suited to the particular use contemplated. It is intended that the scope of this disclosure be defined by the following claims and their equivalents:

We claim:

1. A system comprising:

a picker including

a pump block including a first end and a second end including a seal;

a piston at least partially housed within the pump block and partially extending through the seal, the pump block to allow translation of the piston relative to the pump block;

a cannula including an adapter end and a tube end, wherein the adapter end connects to the pump block with the tube end extended away from the pump block;

a driver;

a coupling to mate the driver to the piston;

an actuator to move the picker along at least one of the x-, y-, or z-axes; and

a mount to connect to the actuator to attach the picker and the driver to an imaging or detection system.

2. The system of claim 1, wherein the actuator has a travel range of 1 nanometer to more than 50 millimeters along the at least one axis.

3. A system comprising:

a picker including

11

a pump block including a first end and a second end including a seal;

a piston at least partially housed within the pump block and partially extending through the seal, the pump block to allow translation of the piston relative to the pump block; 5

a cannula including an adapter end and a tube end, wherein the adapter end connects to the pump block with the tube end extended away from the pump block; 10

a driver;

a coupling to mate the driver to the piston; and

a housing including a travel slot and a screw, the screw to be inserted through the travel slot and screwed into a threaded hole on a side of the pump block to set the maximum permissible travel of the pump block relative to the housing, 15

wherein the housing supports the driver.

4. A system comprising: 20

a picker including

a pump block including a first end and a second end including a seal;

a piston at least partially housed within the pump block and partially extending through the seal, the pump block to allow translation of the piston relative to the pump block; 25

a cannula including an adapter end and a tube end, wherein the adapter end connects to the pump block with the tube end extended away from the pump block; 30

a driver;

a coupling to mate the driver to the piston; and

a housing including a travel slot and a screw, the screw to be inserted through the travel slot and the screw to be inserted through the travel slot and compressed against a side of the pump block to set the maximum permissible travel of the pump block relative to the housing, 35

wherein the housing supports the driver.

12

5. A system comprising:

a picker including

a pump block including a first end and a second end including a seal;

a piston at least partially housed within the pump block and partially extending through the seal, the pump block to allow translation of the piston relative to the pump block;

a cannula including an adapter end and a tube end, wherein the adapter end connects to the pump block with the tube end extended away from the pump block;

a driver;

a coupling to mate the driver to the piston;

an actuator to move the picker along at least one of the x-, y-, or z-axes;

a base to at least partially support the picker; and

a light source on the base to illuminate the tube end of the cannula.

6. A system comprising: 20

a picker including

a pump block including a first end and a second end including a seal;

a piston at least partially housed within the pump block and partially extending through the seal, the pump block to allow translation of the piston relative to the pump block;

a cannula including an adapter end and a tube end, wherein the adapter end connects to the pump block with the tube end extended away from the pump block; 30

a driver;

a coupling to mate the driver to the piston;

a base to at least partially support the picker; and

a housing including at least one spring extending to the base to bias and preload threads of the piston to reduce or eliminate change or backlash. 35

* * * * *