



US009494365B2

(12) **United States Patent**
McMahon et al.

(10) **Patent No.:** **US 9,494,365 B2**

(45) **Date of Patent:** **Nov. 15, 2016**

(54) **SELF-CLEANING JET TUBE**

(71) Applicant: **USNR, LLC**, Woodland, WA (US)

(72) Inventors: **Irven J. McMahon**, Painesville, OH (US); **Clinton Spangler**, Mentor, OH (US)

(73) Assignee: **USNR, LLC**, Woodland, WA (US)

(*) Notice: Subject to any disclaimer, the term of this patent is extended or adjusted under 35 U.S.C. 154(b) by 0 days.

(21) Appl. No.: **14/875,551**

(22) Filed: **Oct. 5, 2015**

(65) **Prior Publication Data**

US 2016/0102913 A1 Apr. 14, 2016

Related U.S. Application Data

(60) Provisional application No. 62/062,037, filed on Oct. 9, 2014.

(51) **Int. Cl.**

F26B 13/00 (2006.01)
F26B 21/00 (2006.01)
B05B 1/20 (2006.01)
B05B 15/02 (2006.01)
B23P 15/00 (2006.01)

(52) **U.S. Cl.**

CPC **F26B 21/004** (2013.01); **B05B 1/205** (2013.01); **B05B 15/0208** (2013.01); **F26B 13/008** (2013.01); **B23P 15/00** (2013.01); **F26B 2210/14** (2013.01)

(58) **Field of Classification Search**

CPC B05B 1/02; B05B 1/14; B05B 1/20; B05B 1/205; B05B 9/002; B05B 15/02; B05B 15/0208; B05B 17/0638; F26B 13/008; F26B 21/004; F26B 2210/14

See application file for complete search history.

(56) **References Cited**

U.S. PATENT DOCUMENTS

4,021,931 A 5/1977 Russ et al.
4,132,363 A * 1/1979 Kruger B05B 1/044
239/455

(Continued)

FOREIGN PATENT DOCUMENTS

CA 1181235 1/1985
JP 2008302309 A 12/2008
JP 2013007532 A 1/2013

OTHER PUBLICATIONS

Canadian Patent Application No. 2,909,023 Office Action dated Jan. 13, 2016, 5 pages.

(Continued)

Primary Examiner — Ryan Reis

(74) *Attorney, Agent, or Firm* — Schwabe Williamson & Wyatt, P.C.

(57) **ABSTRACT**

Embodiments of a self-cleaning jet tube may include an elongate hollow body that is generally rectangular in cross-section and tapered from an open first end to a second end generally opposite the first end. The elongate hollow body may have an upper wall, a lower wall, side walls, a plurality of apertures arranged along the upper wall, an end plate coupled with the walls at the second end, and at least one through-slot. A through-slot may be disposed through the end plate or a wall, between the end plate and a wall, or between two walls. The jet tube may be configured for use with the through-slot(s) open and unblocked, thereby allowing debris to be expelled from the jet tube during operation of the jet veneer dryer. Corresponding systems and method are also provided herein.

30 Claims, 9 Drawing Sheets

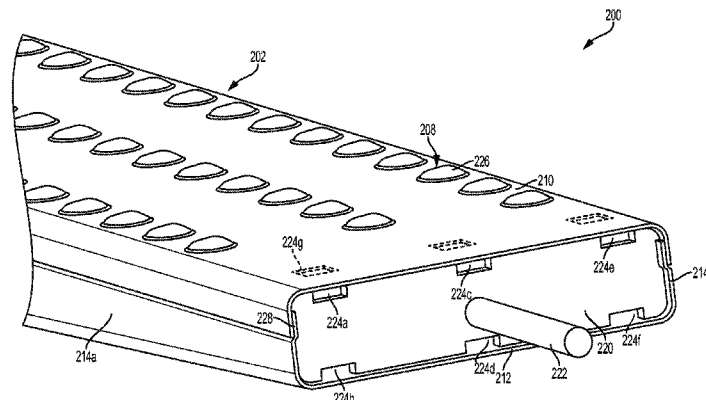

(56)

References Cited

U.S. PATENT DOCUMENTS

4,155,178 A * 5/1979 Weldon F26B 21/004
239/557
4,782,600 A 11/1988 Coulson
4,919,336 A * 4/1990 Hudon D21F 1/34
162/275
5,850,841 A * 12/1998 Han H01L 21/67051
134/198
6,250,318 B1 * 6/2001 Kiat B05B 1/20
134/122 R
7,254,902 B2 8/2007 Kayasaka et al.
7,650,897 B2 * 1/2010 Kopp B05B 1/205
134/198

OTHER PUBLICATIONS

PCT Application No. PCT/US2015/0584078 International Search Report and Written Opinion dated Jan. 12, 2016, 20 pages.

“Anti-Plug Retrofit Veneer Jet Dryer Tube,” Web page <<http://northwestdryer.com/plywood/dryer-parts/jet-tubes>>, 3 pages, Sep. 9, 2012, retrieved from Internet Archive Wayback Machine <<https://web.archive.org/web/20131102090155/http://northwestdryer.com/2013-04-19-21-39-39/plywood/dryer-parts/2012-09-09-22-37-30/jet-tubes>> on May 6, 2016.

“Anti-Plug Retrofit Veneer Jet Dryer Tube,” Web page <<http://www.northwestdryer.com/jettubes.htm>>, 3 pages, Mar. 29, 2009, retrieved from Internet Archive Wayback Machine <<https://web.archive.org/web/20090329235235/http://www.northwestdryer.com/jettubes.htm>> on May 6, 2016.

“WestmillParts.pdf,” Web page <<http://www.westmillindustries.com/parts.php>>, 24 pages, Jul. 19, 2013, retrieved from Internet Archive Wayback Machine <<https://web.archive.org/web/20130719202428/http://www.westmillindustries.com/parts.php>> on May 6, 2016.

Canadian Patent Application No. 2,909,023 Office Action dated Apr. 21, 2016, 4 pages.

* cited by examiner

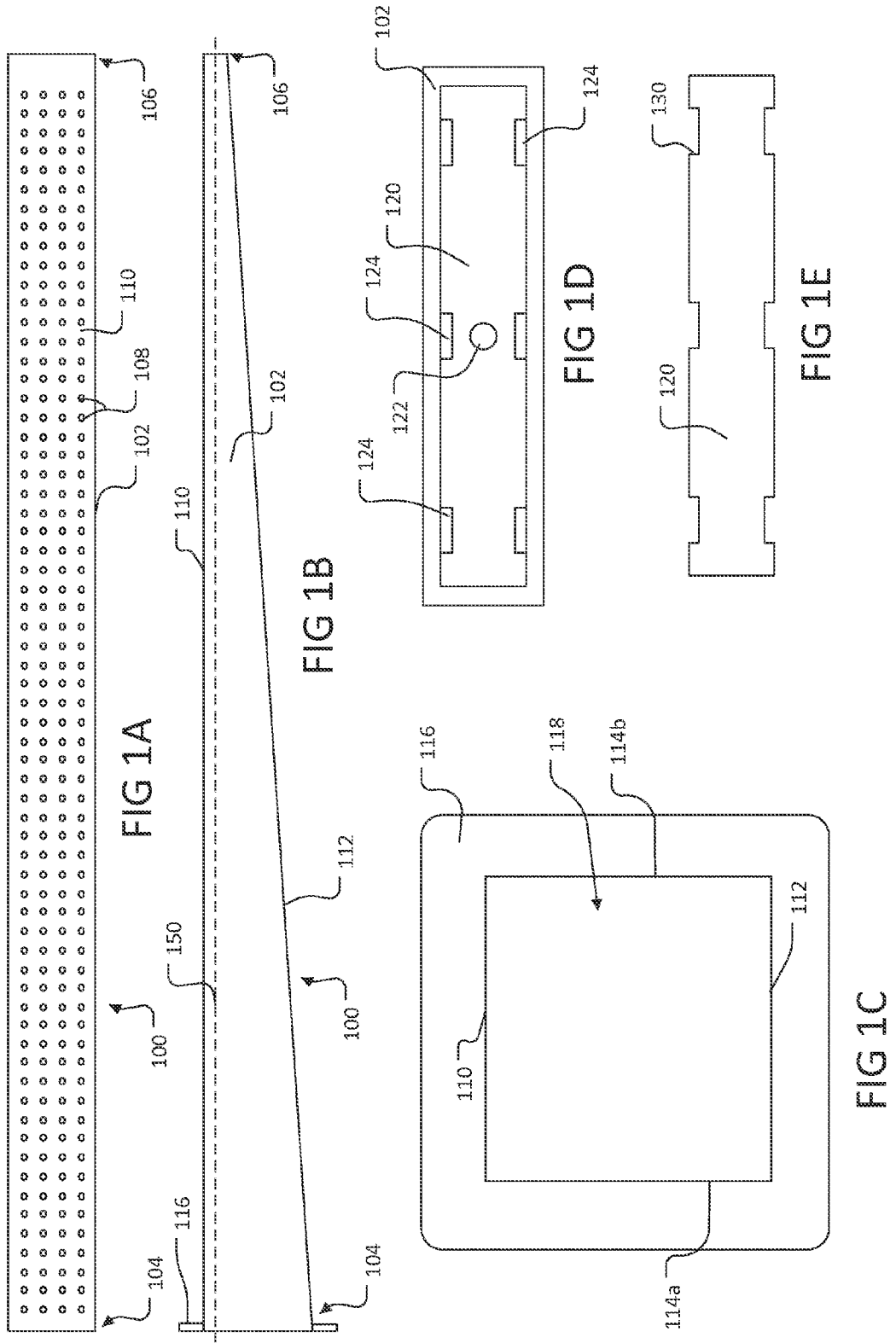

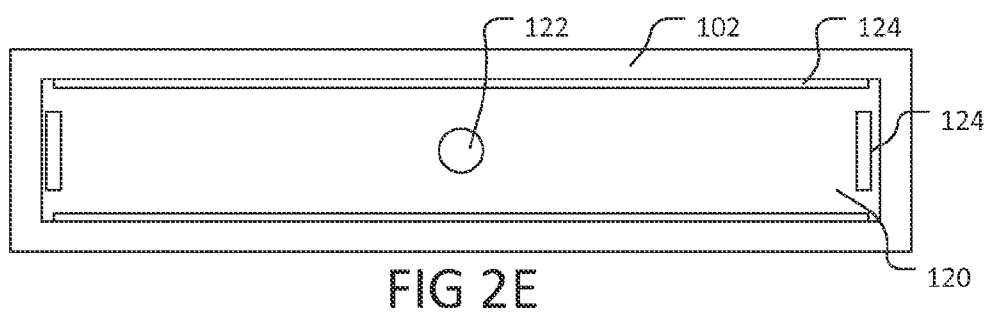
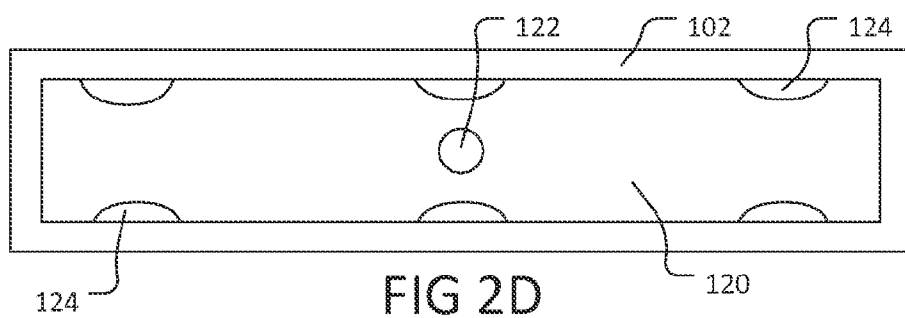
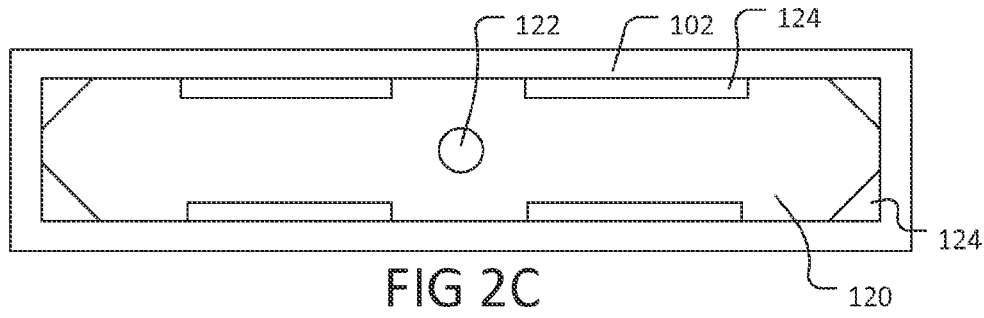
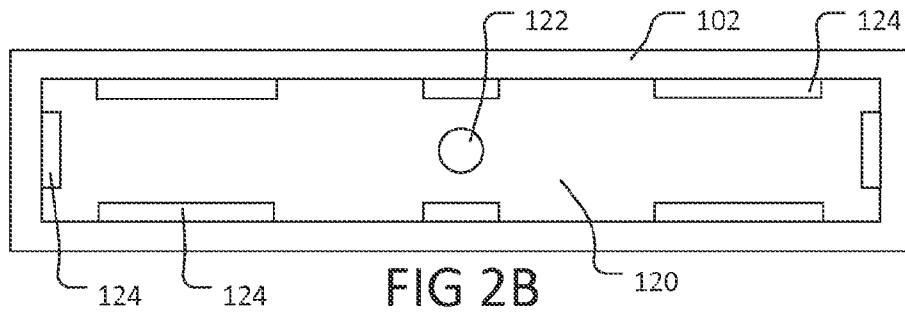
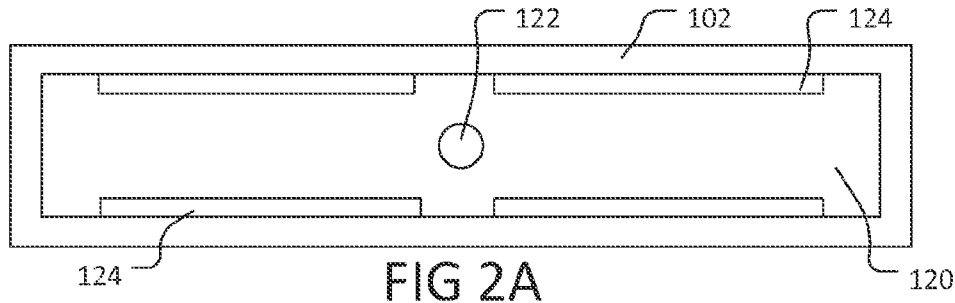

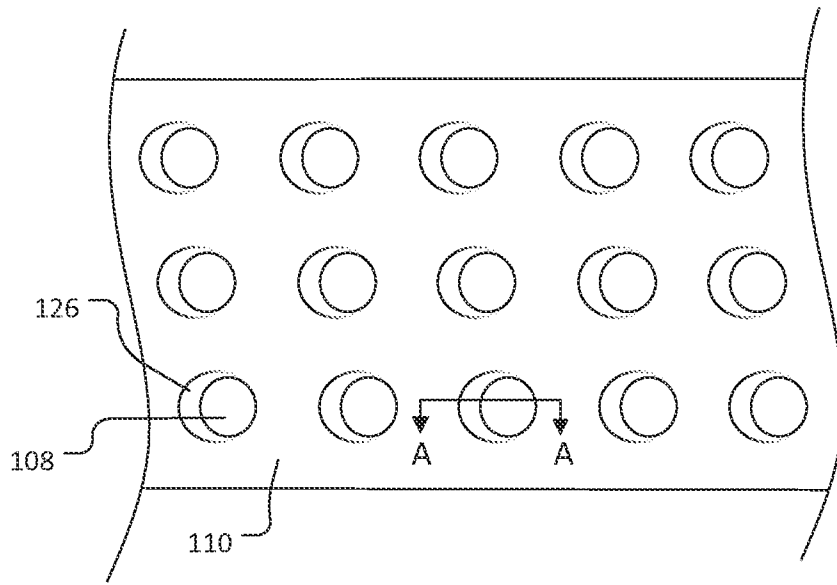

FIG 3A

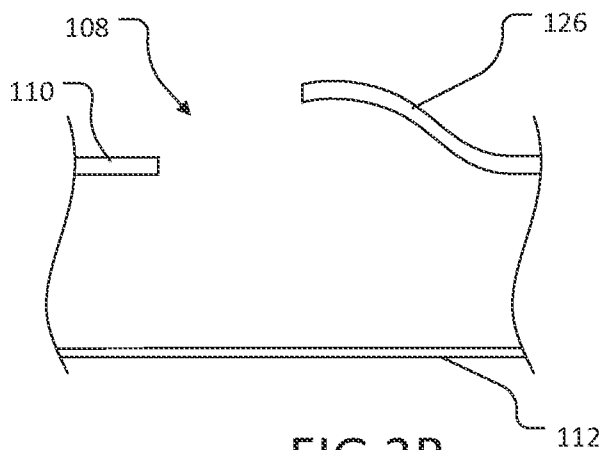

FIG 3B

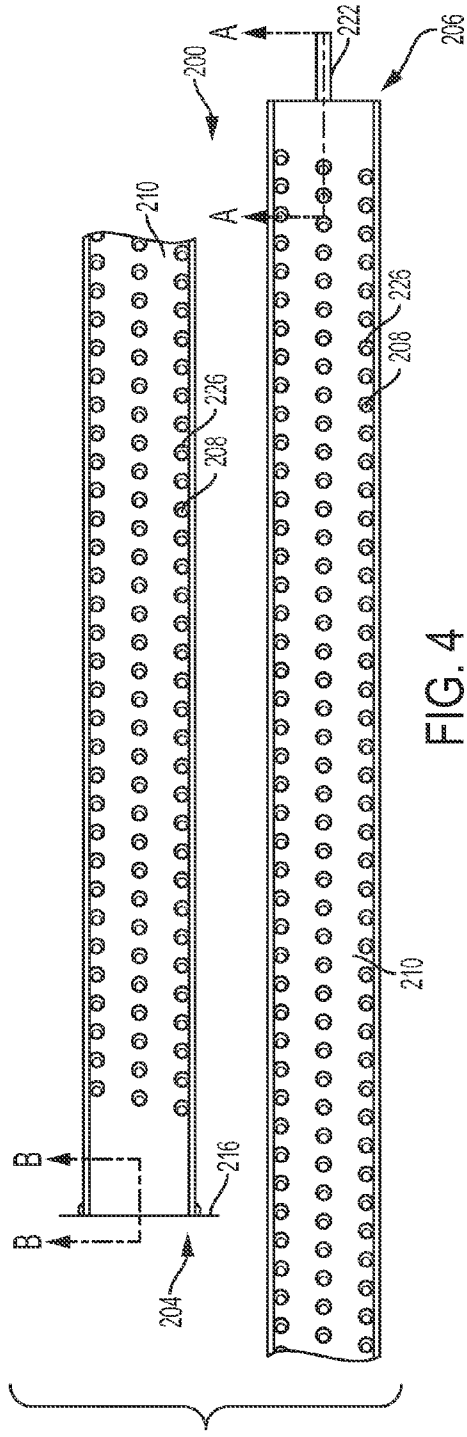

FIG. 4

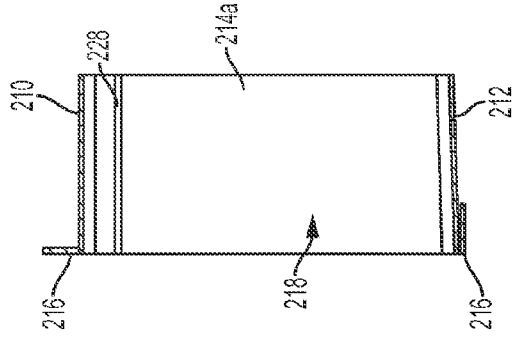

FIG. 5B

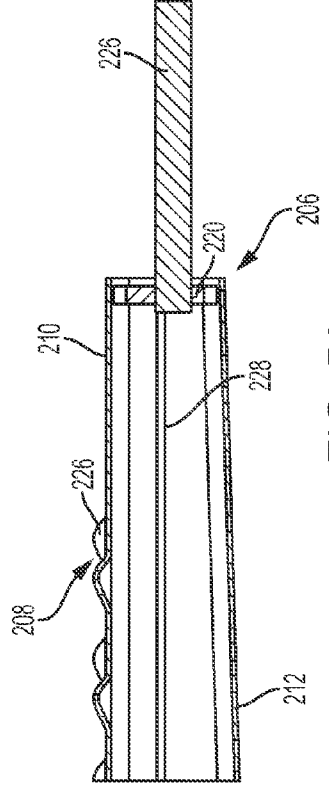

FIG. 5A

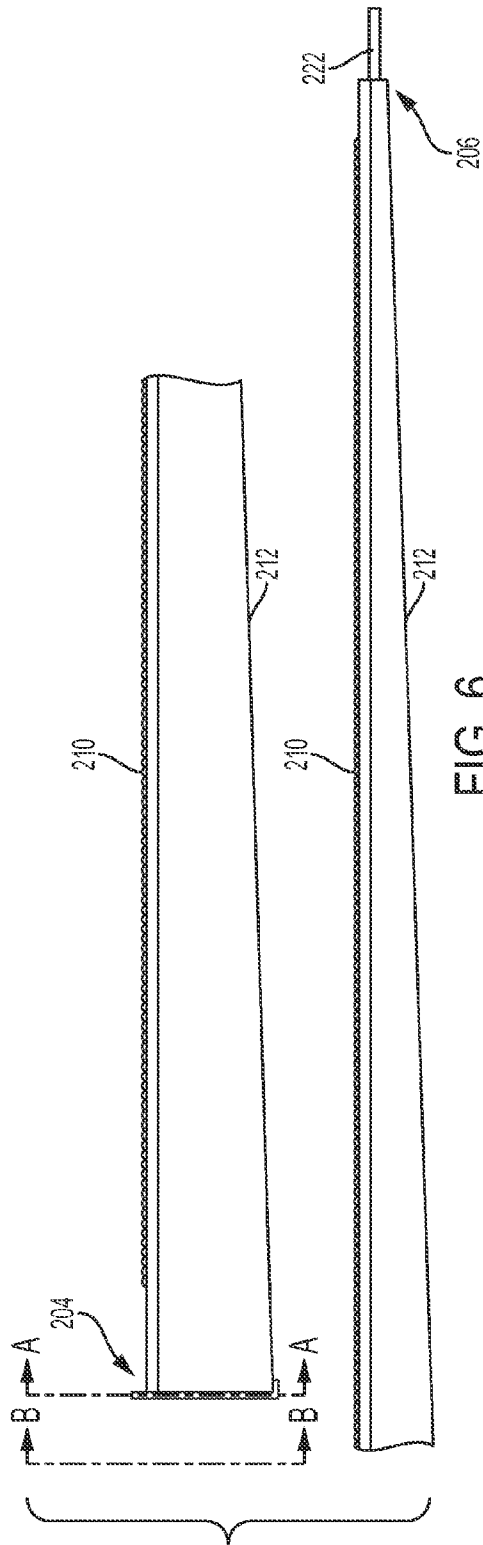

FIG. 6

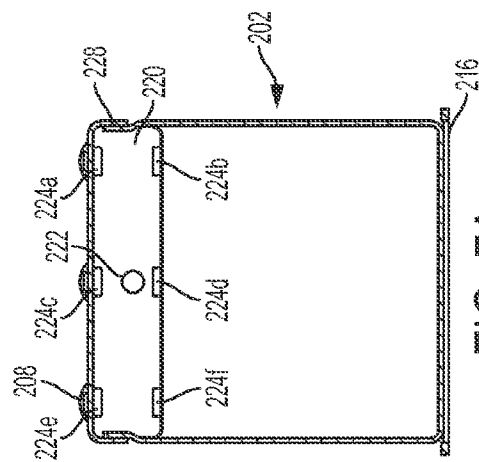

FIG. 7A

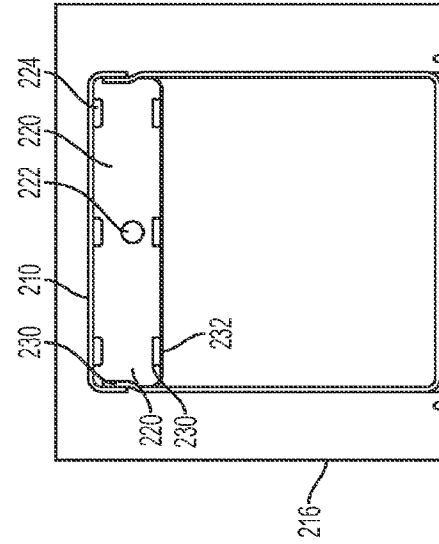

FIG. 7B

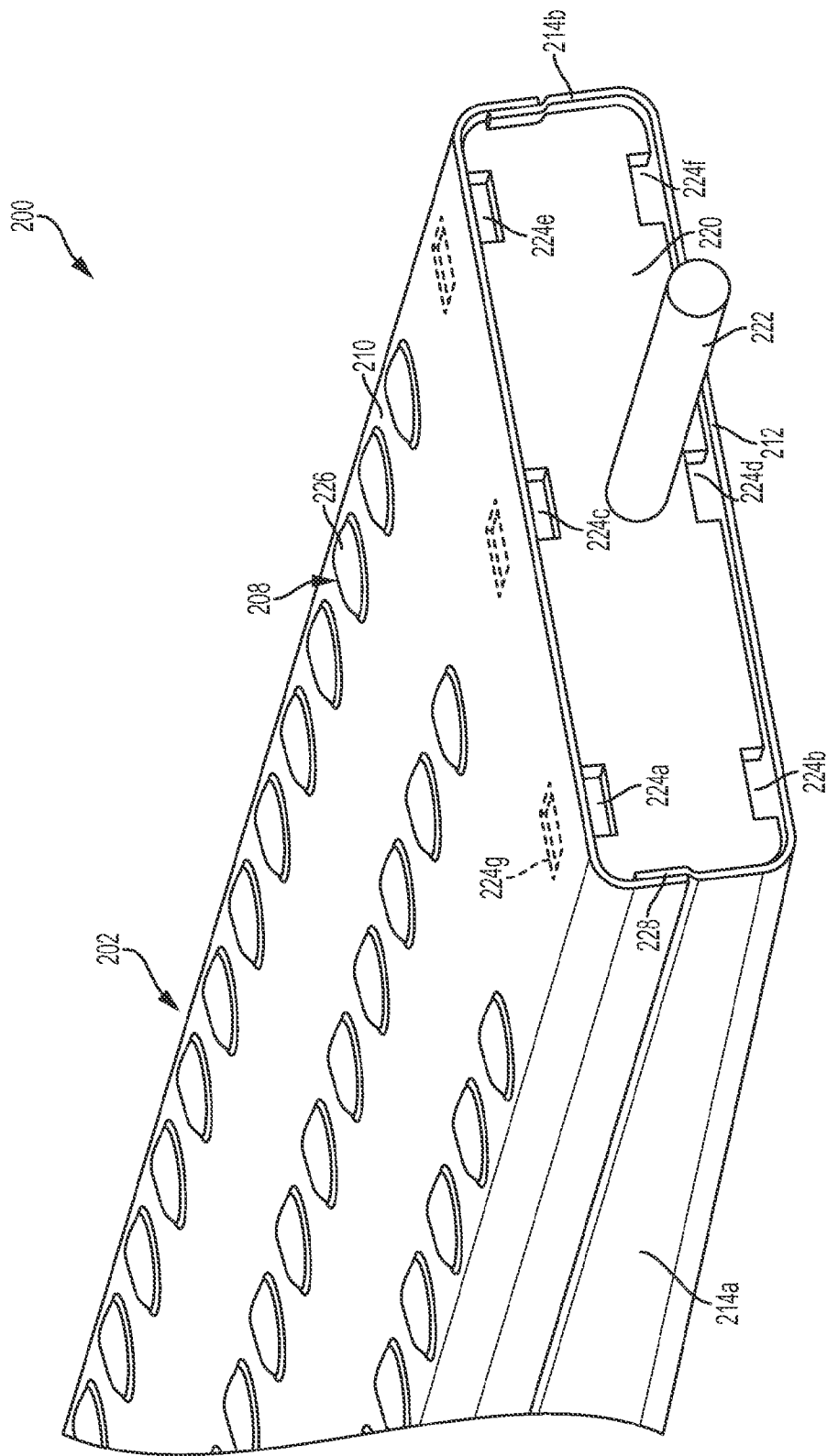

FIG. 8

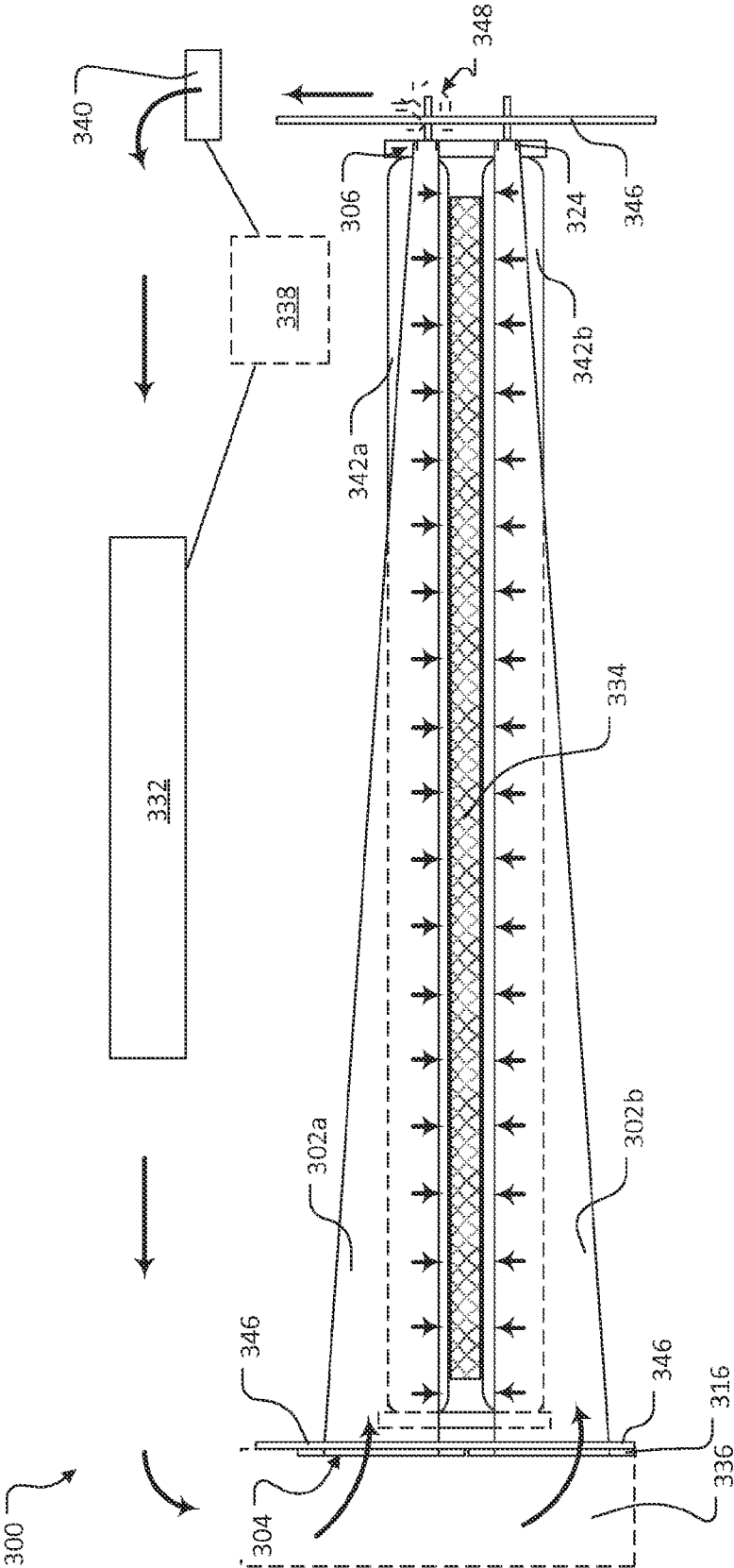

FIG 9

400

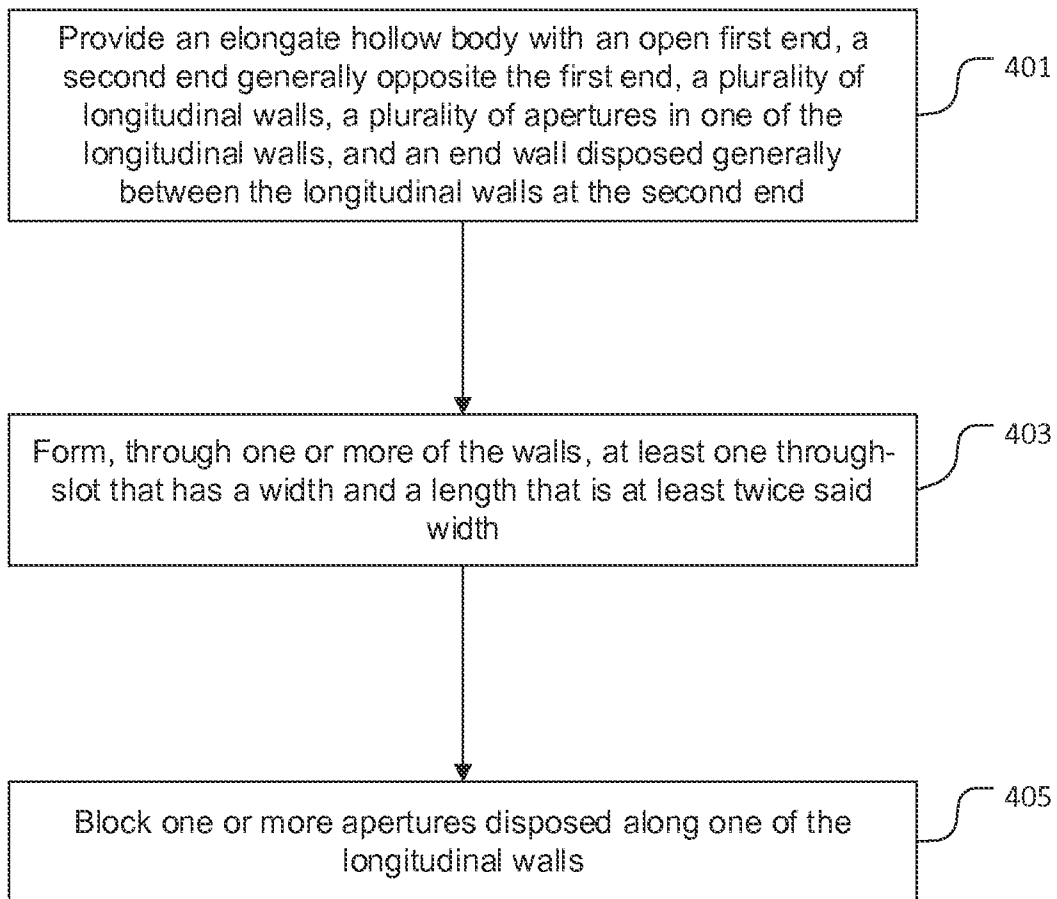

FIG 10

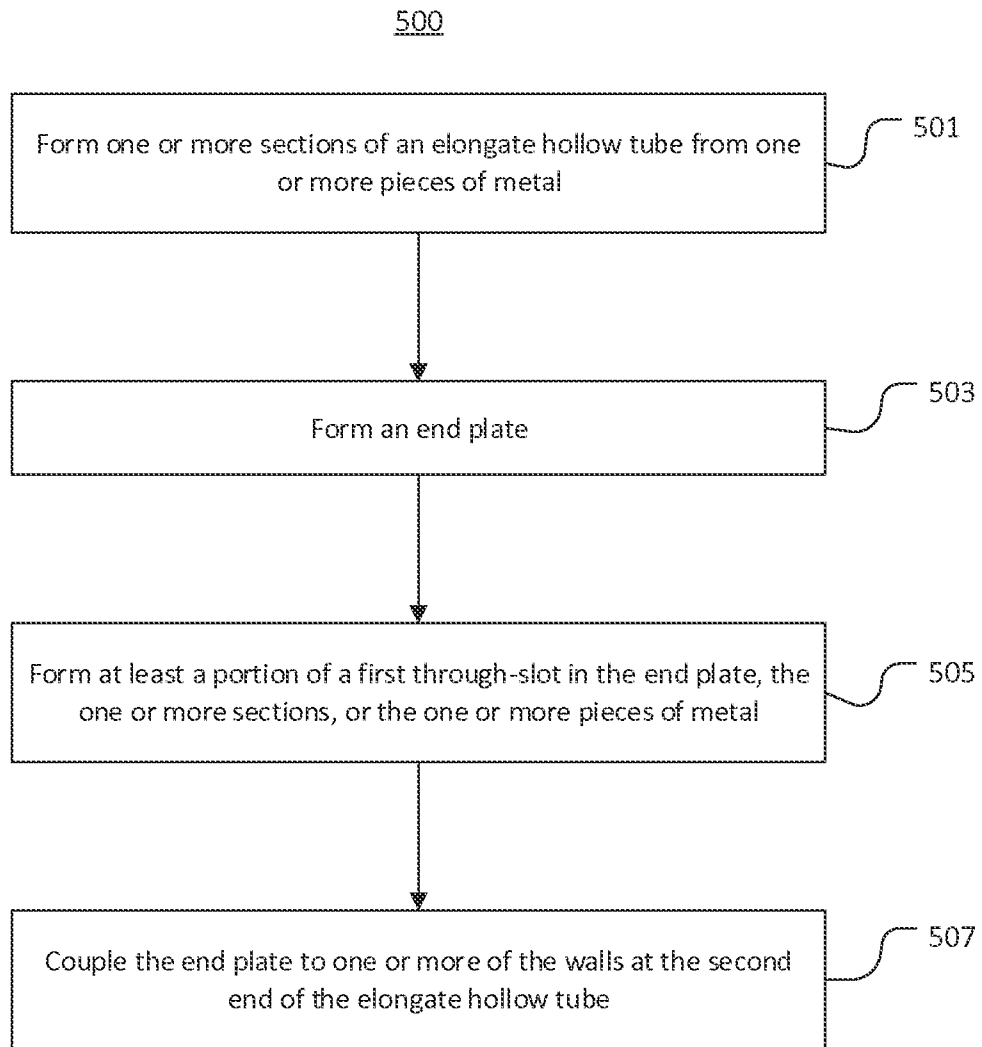

FIG 11

SELF-CLEANING JET TUBE**CROSS REFERENCE TO RELATED APPLICATIONS**

The present application claims priority to U.S. Patent Application No. 62/062,037 filed Oct. 9, 2014 and titled "Self-Cleaning Jet Tube," the entire disclosure of which is hereby incorporated by reference.

BACKGROUND

Veneer dryers are commonly used in the wood products industry to lower the moisture content of veneer for plywood manufacturing and other applications. Logs are peeled or sliced to produce sheets of "wet" veneer, which is then loaded into a veneer dryer for drying. If the veneer is not dried to a particular moisture content, further processing stages may be adversely affected. For example, if the veneer will be glued to another layer of wood, too much residual moisture may prevent proper adhesion. Conversely, veneer that is too dry may absorb more glue, resulting in higher processing costs.

Jet veneer dryers have become increasingly popular. Jet veneer dryers are designed to dry veneer by directing air to impinge on the veneer surface at high velocities, commonly 2,000-10,000 feet per minute. Veneer jet dryers may be either direct-fired or indirect-heated. In direct-fired dryers, hot combustion gases from a direct fired air heater are blended with recirculated air from the dryer to reduce the combustion gas temperature. The blended gases are then circulated over the veneer. In contrast, indirect-heated veneer dryers use steam or circulated hot oil coils to heat the recirculated air before it passes over the veneer.

A typical jet veneer dryer is an elongate chamber with an upstream drying section, a downstream cooling section, and 1-6 vertically stacked "decks" extending from the input end of the drying section to the output end of the cooling section. Within the drying section, each deck has upper and lower driven rollers or belts for conveying the sheets of veneer along a corresponding flow path through the drying section. Between adjacent pairs of veneer rollers or belt supporting rollers are positioned pairs of elongated vertically-opposed jet tubes that extend horizontally across the deck from an air-delivery side to a generally opposite air return side. The drying section also includes an air circulation system with air-delivery side plenum, a return side plenum, heaters, and fans.

The jet tubes are generally rectangular in cross-section and tapered longitudinally from a large open end at the air-delivery side to a small closed end with a mounting bracket at the return side. The large open end is usually sealed against the framework of the drying section by a plate or other such feature. A plurality of apertures are provided along one surface of the jet tubes. Some of the jet tubes are mounted below the veneer flow path in an aperture-side-up orientation, and others are mounted above the veneer flow path in an aperture-side-down orientation. Heated air moves under pressure from the air-delivery side plenum into the open end of the jet tubes, flowing through the holes in the veneer-facing surfaces of the jet tubes and against the veneer moving along the flow path.

Jet dryers have some disadvantages. One drawback is that the narrow ends of the jet tubes tend to become plugged with accumulated debris. The accumulated debris reduces the flow of heated air at the return side of the decks, and can also cause a fire within the drying section. Conventional jet

dryers must be cleaned typically at three week intervals to remove condensed volatile organic compounds (VOC's) and wood debris. A common method of removing debris from jet tubes involve using a flood of water that back washes and floats the debris from the tube as it drains. Another method uses a water or air lance which is activated after the lance is inserted from the large end of the tube to the small end and then is slowly backed out removing the debris as the lance is removed. Some jet tubes have a small aperture at the narrow end and a movable or removable cap or plug fitted over the opening to allow air or water to be introduced through the opening in the narrow end. A fourth method is to remove each jet tube from the dryer, position the jet tube vertically with the tapered end up, and pound the open end of the jet tube against the floor to dislodge debris. These cleaning methods are time-consuming, labor-intensive, and costly, and can present a risk to personnel.

BRIEF DESCRIPTION OF THE DRAWINGS

Embodiments will be readily understood by the following detailed description in conjunction with the accompanying drawings. Embodiments are illustrated by way of example and not by way of limitation in the figures of the accompanying drawings.

FIGS. 1A-E illustrate schematic views of an embodiment of a self-cleaning jet tube;

FIGS. 2A-2E illustrate block diagrams of embodiments of a self-cleaning jet tube;

FIGS. 3A-B illustrate an example configuration of apertures for a self-cleaning jet tube;

FIG. 4 illustrates a plan view of an embodiment of a self-cleaning jet tube;

FIGS. 5A-B illustrate sectional views taken along lines A-A and B-B, respectively, of FIG. 4;

FIG. 6 illustrates a side elevational view of the jet tube of FIG. 5;

FIGS. 7A-B illustrate sectional views taken along lines A-A and B-B, respectively, of FIG. 6;

FIG. 8 illustrates a partial perspective view of the embodiment of FIGS. 5A-7B;

FIG. 9 illustrates a block diagram of a jet veneer dryer system;

FIG. 10 illustrates a method of forming a self-cleaning jet tube; and

FIG. 11 illustrates another method of forming a self-cleaning jet tube, all in accordance with various embodiments.

DETAILED DESCRIPTION OF DISCLOSED EMBODIMENTS

In the following detailed description, reference is made to the accompanying drawings which form a part hereof, and in which are shown by way of illustration embodiments that may be practiced. It is to be understood that other embodiments may be utilized and structural or logical changes may be made without departing from the scope. Therefore, the following detailed description is not to be taken in a limiting sense, and the scope of embodiments is defined by the appended claims and their equivalents.

Various operations may be described as multiple discrete operations in turn, in a manner that may be helpful in understanding embodiments; however, the order of description should not be construed to imply that these operations are order dependent.

The description may use perspective-based descriptions such as up/down, back/front, and top/bottom. Such descriptions are merely used to facilitate the discussion and are not intended to restrict the application of disclosed embodiments.

The terms “coupled” and “connected,” along with their derivatives, may be used. It should be understood that these terms are not intended as synonyms for each other. Rather, in particular embodiments, “connected” may be used to indicate that two or more elements are in direct physical or electrical contact with each other. “Coupled” may mean that two or more elements are in direct physical or electrical contact. However, “coupled” may also mean that two or more elements are not in direct contact with each other, but yet still cooperate or interact with each other.

As used herein, the term “through-slot” means a passage through a generally solid structure, such as a plate or a wall of a hollow body, or a passage between two such structures. Unless otherwise indicated, a given through-slot can have any shape (e.g., square, rectangular, triangular, circular, semicircular, ovoid, trapezoidal) or size. A through-slot may be formed by removing material from a solid structure or a component thereof (e.g., by cutting), by forming the solid structure and the through-slot simultaneously (e.g., by molding), by coupling the solid structure to another structure in a manner that leaves a gap between the structures that serves as a through-slot, by coupling the solid structure to another structure and moving (e.g., bending) a portion of the solid structure away from the other structure to create a gap that serves as a through-slot, and/or by any other suitable method.

For the purposes of the description, a phrase in the form “NB” or in the form “A and/or B” means (A), (B), or (A and B). For the purposes of the description, a phrase in the form “at least one of A, B, and C” means (A), (B), (C), (A and B), (A and C), (B and C), or (A, B and C). For the purposes of the description, a phrase in the form “(A)B” means (B) or (AB) that is, A is an optional element.

The description may use the terms “embodiment” or “embodiments,” which may each refer to one or more of the same or different embodiments. Furthermore, the terms “comprising,” “including,” “having,” and the like, as used with respect to embodiments, are synonymous.

In exemplary embodiments, a computing device may be endowed with one or more components of the disclosed apparatuses and/or systems and may be employed to perform one or more methods as disclosed herein.

Embodiments described provide self-cleaning jet tubes suitable for use in both direct-fired and indirect-heated jet veneer dryers. In direct-fired dryers, hot combustion gases from direct fired air heaters are blended with recirculated air from the dryer to reduce the combustion gas temperature. The blended gases are then circulated over the veneer. In contrast, indirect-heated veneer dryers use steam or circulated hot oil coils to heat air before circulating the heated air over the veneer. In these dryers, debris must pass through the heating coils to get into the jet tubes. Due in part to factors such as fin spacing and veneer thickness, most of the pieces of debris that collect in the jet tubes of indirect-heated veneer dryers are less than $\frac{1}{2}'' \times \frac{1}{2}'' \times \frac{1}{16}''$. Moreover, they tend to collect primarily on the bottom of the jet tube toward the narrow end where the conveying velocity approaches zero. While it is theoretically possible for larger debris to enter the jet tubes in a direct-fired veneer dryer, a substantial percentage of the pieces of debris are likely to be smaller, as in indirect-heated veneer dryers.

In various embodiments, a self-cleaning jet tube may be provided with one or more through-slots configured to provide a passage through which debris can be blown from the interior of the jet tube during normal drying operations of the jet veneer dryer. A self-cleaning jet tube may be configured to be used with the through-slot(s) open and unblocked while in use. Thus, a self-cleaning jet tube may lack plugs or caps configured to block air loss through the through-slots. The dimensions, placement, and/or number of through-slots may vary among embodiments. However, in some embodiments a through-slot may be configured to provide continuous evacuation of debris from the jet tube without substantially reducing the air pressure at the apertures.

In various embodiments, a self-cleaning jet tube may include an elongate hollow body with a generally open first end, a generally closed second end, and one or more through-slots. The elongate hollow body may be generally rectangular in cross-section, with four sides and a plurality of apertures arranged along one of the sides. For ease of reference, the description below refers to the side with the apertures as the “top” or “upper” wall, and refers to the other sides as the “lower” or “bottom” wall and “side” walls. However, other embodiments may have different cross-sectional shapes and/or numbers of sides (e.g., round, ovoid, semi-circular, three-sided, five-sided, six-sided, etc.).

Similarly, it is to be understood that the term “wall” is used in reference to a corresponding portion of the elongate hollow body. As such, a wall can be either a discrete structure or an area of a larger structure. For example, an elongate hollow body with a generally rectangular cross-section may be constructed by bending or shaping one piece of material such that it forms all of the walls, or by joining four separate and generally planar pieces of material, or by bending and shaping one piece of material and joining that piece of material to another, or the like. As another example, an elongate hollow body with a semi-circular cross-sectional shape may have one generally planar wall and one curved wall, and the side walls and the upper or lower wall are corresponding portions of the curved wall. Similarly, in a hollow body with a round or ovoid cross-sectional shape, the upper, lower, and/or side walls may be corresponding portions of a single wall. Regardless of the cross-sectional shape or the manner of construction, the portions of the elongate hollow body that correspond to the top (i.e., portion with the apertures), bottom, and sides of the elongate hollow body are referred to herein as the top or upper wall, the bottom or lower wall, and the side walls.

The generally closed second end may include an end plate coupled with the upper, lower, and/or side walls. The end plate may be formed as a separate component and coupled with the upper, lower, and/or side walls by welding or other suitable means. Alternatively, the end plate may be formed as an integral portion of the elongate hollow body. For example, in some embodiments the end plate may be formed by bending a distal end of one or more of the walls toward a longitudinal centerline that extends through the elongate hollow body.

One or more through-slots may be disposed in the end plate, in one or more of the walls, between two of the walls, or between the end plate/wall and one or more of the other walls. Optionally, some or all of the through-slots may be at or near the second end of the elongate hollow body.

In some embodiments, with the exception of the through-slot(s), a self-cleaning jet tube may otherwise have the same or similar configuration as a conventional jet tube. In other embodiments, a self-cleaning jet tube may have a configu-

ration that differs from that of a conventional jet tube in other respects, such as in the number of apertures.

In various embodiments, the size, shape, location, and/or number of through-slots may be configured to optimize the evacuation of debris from the jet tube. For example, in some embodiments a through-slot may be generally oblong in shape. Optionally, the greatest length of the through-slot may be at least twice the greatest width of the through-slot. In other embodiments, the length of the through-slot may be 1.5-3 times, 2-4 times, 3-5 times, or more than 5 times the width of the through-slot.

In some embodiments, the apertures may be arranged in rows along a wall or surface of the jet tube, and a through-slot may be positioned in alignment with one of the rows. The airflow along or near a row of apertures may be greater than in other areas (e.g., between the rows), which may enhance the evacuation of debris through the through-slot that is aligned.

In some embodiments, one or more through-slots may be positioned along or near the top wall and/or bottom wall of the jet tube. This may help to evacuate more debris due to the effect of gravity, which may cause debris to settle downward onto the interior side of the top wall (if the jet tube is in the top-side-down orientation) or bottom wall (if the jet tube is in the top-side-up orientation) within the jet tube. Thus, in some embodiments, through-slots may be provided along generally opposite walls of the jet tube to accommodate the use of the jet tube in two orientations. For example, a first through-slot may be positioned along or near the top wall and a second through-slot may be positioned along or near the bottom wall. Optionally, the first and second through-slots may be vertically aligned with one another and/or with a row of apertures.

In addition, the size, shape, and/or number of apertures may be adjusted to offset the effect of airflow through the through-slots. For example, some prior jet tubes include a particular number of apertures (e.g., 303 apertures) arranged in rows of a particular length to provide airflow across an area slightly wider than the typical veneer path. A corresponding embodiment of a self-cleaning jet tube may include a slightly reduced number of apertures (e.g., 300 apertures) arranged in slightly shorter rows to provide airflow across an area substantially the same width as the typical veneer path. The elimination of a small number of apertures may offset the loss of air through the through-slot(s) at the narrow end of the jet tube. Alternatively, the apertures may be reduced in size and/or arranged in other configurations to offset air loss through the through-slot(s).

In a particular embodiment, a jet tube may have three rows of apertures (e.g., 100 apertures per row), and the end plate may have six through-slots approximately $\frac{3}{16}$ " by $\frac{5}{8}$ " in size. Three of the through-slots may be disposed along the upper edge of the end plate in vertical alignment with corresponding ones of the rows of apertures. Likewise, the other three through-slots may be disposed along the bottom edge of the plate in vertical alignment with corresponding ones of the rows of apertures, such that two through-slots (one upper and one lower) are vertically aligned with each row of apertures.

In some embodiments, a self-cleaning jet tube may be formed by forming one or more through-slots in an existing jet tube. In other embodiments, a self-cleaning jet tube may be formed by constructing an elongate hollow body from one or more sheets of metal (e.g., steel) and forming the through-slot(s) in the sheets of metal before, during, or after construction of the elongate hollow body. In a particular embodiment, the elongate hollow body may be constructed

by forming an upper portion, a lower portion, and an end plate, forming the through-slot(s) in one or more of those components, and coupling the components together (e.g., by welding). In another embodiment, the elongate hollow body may be constructed by forming an upper portion, a lower portion, and an end plate, forming a recess in one or more of those components, and coupling the components together to form a through-between adjacent components.

FIGS. 1A-E illustrate schematic views of an embodiment of a self-cleaning jet tube **100**, in accordance with various embodiments. In embodiments, a jet tube **100** may include an elongate hollow body **102** that is generally rectangular in cross-section and tapers from a generally open first end **104** to a generally opposite second end **106**. Elongate hollow body **102** may have an upper wall **110** with a plurality of apertures **108** (FIG. 1A), a lower wall **112** (FIG. 1B), generally opposite side walls **114a**, **114b** (FIG. 1C), end plate **120**, and one or more through-slots **124**.

In some embodiments, jet tube **100** may further include a flange **116** coupled with the first end **104** of elongate hollow body **102**. Flange **116** may be configured to block air leakage around first end **104** when the jet tube is mounted in a use position within a jet veneer dryer. Optionally, jet tube **100** may include a post **122** coupled with the end plate **120** and/or other portion of elongate hollow body **102**. Post **122** may be configured for use in mounting the jet tube to a frame of a jet veneer dryer.

End plate **120** may be coupled with the upper, lower, and/or side walls of elongate hollow body **102** at the second end **106** (FIG. 1D). In some embodiments, the walls of elongate hollow body **102** may be formed from one or more sheets of metal, and end plate **120** may be formed from a separate sheet of metal and coupled with the walls (e.g. by welding). In other embodiments, end plate **120** may be integral to elongate hollow body **102** or some portion thereof. For example, in some embodiments end plate **120** may be formed by bending a distal end of one or more of the walls **110/112/114a/114b** toward a longitudinal centerline **150** of the elongate hollow body.

In operation, jet tube **100** may be mounted to a jet veneer dryer frame, and heated air may be moved under pressure into the generally open first end **104**. The heated air may flow through the elongated hollow body **102** toward the second end **106**, exiting through apertures **108**. Jet tube **100** may be configured such that the heated air flows from apertures **108** near second end **106** at substantially the same pressure as from apertures **108** near first end **104**. Debris may be pushed into jet tube **100** by the heated air. As the heated air pushes the debris toward the second end **106**, the debris may be blown through one or more through-slots **124**.

The number, size, placement, and configuration of through-slot(s) **124** may vary among embodiments. In some embodiments, end plate **120** may have an outer edge that defines one or more recesses **130** (FIG. 1E). The outer edge of the end plate **120** may be coupled with a wall of the elongate hollow body **102** (e.g., upper wall **110**, lower wall **112**, side **114a** or **114b**) such that the portion extends across an open end of the recess **130** (FIG. 1E). The recess **130** in end plate **120** may define or form part of a through-slot **124**, and the corresponding wall portion may define or form another part of the through-slot **124**, which is thus disposed between the end plate **120** and the corresponding wall(s). Additional examples of end plate and through-slot configurations are illustrated in FIGS. 2A-2E.

The dimensions and shape of recess(es) **130** may vary among embodiments. Although recesses **130** are shown in FIG. 1E as being generally rectangular in shape, in other

embodiments a recess **130** may instead be triangular, semi-circular, ovoid, or any other suitable shape. Likewise, the number and locations of recesses **130** may vary among embodiments. While recesses **130** are shown along the outer edge of the end plate **120** in FIG. 1E, recesses **130** may instead be disposed in an outer edge of one or more of the walls. For example, in some embodiments, recesses **130** may be provided along an edge of upper wall **110**, lower wall **112**, and/or either or both of side walls **114a**, **114b**. Thus, a recess may be formed in an outer edge of any of walls **110**, **120**, **114a**, or **114b**, and the recess and end plate **120** may collectively define a through-slot **124**.

The number and locations of through-slot(s) **124** may also vary among embodiments. In some embodiments, a jet tube **100** may have one or more through-slots along or near upper wall **110** or lower wall **112**. In various embodiments, one or more through-slots **124** may be disposed along a bottom half of jet tube **100** (e.g., between lower wall **112** and a longitudinal center axis **150** of the jet tube) and another one or more through-slots **124** may be disposed along an upper half of each jet tube (e.g., between upper wall **110** and the longitudinal center axis **150**). For example, one or more through-slots **124** may be disposed between end plate **120** and upper wall **110**, and another one or more through-slots **124** may be disposed between end plate **120** and lower wall **112** (see e.g., FIGS. 1D, 2A-2E). Alternatively, one or more through-slots **124** may be disposed between end plate **120** and side wall **114a** or **114b** (see e.g., FIGS. 2B, 2C). Other embodiments may include one or more through-slots **124** formed by two of the walls and the end plate **120** (see e.g., FIG. 2C).

In still other embodiments a through-slot **124** may be disposed in end plate **120** or any one or more of walls **110**, **120**, **114a**, and/or **114b**, rather than between the end plate and a wall. For example, some or all of the through-slots **124** may be disposed through end plate **120** (see e.g., FIG. 2E) or through elongate hollow body **102** (see e.g., **224g** of FIG. 8).

The dimensions of through-slots **124** may vary among embodiments. Optionally, through-slot **124** may be generally oblong, with a length (i.e., longest dimension) that exceeds the width of the through-slot. In some embodiments, the length of through-slot **124** may be at least twice the width. In other embodiments, the length of through-slot **124** may be at least three times the width. In still other embodiments, the length may 1.5-2 times the width. In any case, the depth of a through-slot **124** may be the thickness of the wall or plate through which the through-slot extends. Again, through-slot **124** may have any suitable shape including, but not limited to, rectangular, trapezoidal, ovoid, and semi-circular.

The number and arrangement of apertures **108** may vary among embodiments. FIG. 3A illustrates an example configuration of apertures for a self-cleaning jet tube, and FIG. 3B illustrates a view taken along line A-A of FIG. 3A, all in accordance with various embodiments. Optionally, in some embodiments upper wall **110** may have a plurality of convex or concave dimples **126**, and apertures **108** may be arranged along upper wall **110** to at least partially overlap the dimples **126**. Such configurations may help to direct heated air against a sheet of veneer at a desired angle. Other embodiments may lack dimples **126** or other such surface features, and apertures **108** may be arranged along a generally flat plane. While the apertures **108** are shown arranged in three rows, in other embodiments the apertures may be arranged

in 1-2 rows, more than three rows, or in another pattern such as a grid, staggered, non-linear rows, concentric circles, or in any other manner.

FIGS. 4 and 6 illustrate plan and side elevational views, respectively, of an embodiment of a self-cleaning jet tube **200**. FIGS. 5A-B illustrate sectional views taken along lines A-A and B-B of FIG. 4, and FIGS. 7A-B illustrate sectional views taken along lines A-A and B-B of FIG. 6. FIG. 8 illustrates a partial perspective view of a self-cleaning jet tube, all in accordance with various embodiments.

Jet tube **200** may have an elongate hollow body **202** with an upper wall **210**, a lower wall **212**, side walls **214a**, **214b**, and an end plate **220** coupled with some or all of the walls. Apertures **208** may be arranged in three rows along upper wall **210** to overlap corresponding dimples **226**. End plate **220** may have an upper edge with recesses **230** defined therein and a lower edge with additional recesses **230** defined therein (FIG. 8B). Each of the recesses may be aligned with a corresponding one of the rows of apertures. Thus, as illustrated, jet tube **200** may have three through-slots **224a**, **224c**, **224e** between end plate **220** and upper wall **110**, and another three through-slots **224b**, **224d**, **224f** between end plate **220** and lower wall **212**.

In some embodiments, end plate **220** may have a one or more additional recesses **230** along its lateral edges. In some embodiments, an additional recess **230** may be provided along one or both lateral edges of end plate **220** to form a corresponding through-slot **224** between end plate **220** and one of the side walls **214a** or **214b**.

In other embodiments, an additional recesses **230** may be configured to accommodate a seam **228** (FIG. 5A) along one or more of the walls. Referring to FIG. 8 by way of example, jet tube **200** may have a first section that forms the upper wall **210** and an upper portion of side walls **214a**, **214b**, and a second section that forms the lower wall **212** and a lower portion of side walls **214a**, **214b**. The sections may be cut/shaped or otherwise constructed from one piece of metal (e.g., a sheet of steel) or two or more pieces of metal. When fitted together, the corresponding edges of the sections may overlap at seam **228**. Optionally, the corresponding edges may be coupled together at seam **228** by welding or other suitable techniques. However, the number and configuration of sections may vary among embodiments, and some embodiments may have only one section, one section and an end plate, more than two sections and an end plate, or any other number of sections coupled together in any suitable manner.

Optionally, some or all of the through-slots **224** may be approximately $\frac{3}{16}$ " wide and $\frac{3}{8}$ " long. Alternatively, some or all of the through-slots may be approximately $\frac{1}{16}$ " to $\frac{5}{16}$ " wide and $\frac{3}{8}$ " to $\frac{7}{8}$ " long. In other embodiments, through-slots **224** may vary in number, size, shape, and/or location.

Upper through-slots **224a**, **224c**, and **224e** may be positioned substantially in vertical alignment with corresponding ones of the rows of apertures. Likewise, lower through-slots **224b**, **224d**, and **224f** may be positioned substantially in vertical alignment with corresponding ones of the rows of apertures, such that through-slots **224a** and **224b** are vertically aligned with a first row of apertures, through-slots **224c** and **224d** are vertically aligned with a second row of apertures, and through-slots **224e** and **224f** are vertically aligned with the third row of apertures.

In other embodiments, one or more of the through-slots may be disposed through the end plate **220**. In still other embodiments, one or more of the through-slots may be disposed through the upper, lower, and/or side walls (see e.g., FIG. 8, alternative through-slots **224g** shown in dotted

lines). Various embodiments may have a through-slot disposed through the end plate, and/or a through-slot disposed through one or more walls of the elongate hollow body, and/or a through-slot disposed between the end plate and a wall of the elongate hollow body.

Optionally, some or all of the through-slots may be located near the narrower second end **206** of the jet tube. For example, in some embodiments some or all of the through-slots may be positioned at or near an intersection between the end plate and one or more of the walls of the elongate hollow body. In other embodiments, some or all of the through-slots may be positioned between the end plate and the rows of apertures. In still other embodiments, through-slots may be provided between apertures or between the rows of apertures.

In various embodiments, jet tube **200** may have **300** apertures **308** arranged in three rows (**100** apertures per row). In other embodiments, jet tube **200** may have fewer than **300** apertures or more than **300** apertures. In some embodiments, jet tube **200** may have a reduced number of apertures in comparison to a conventional jet tube. Optionally, jet tube **200** may have the same number of rows of apertures as a conventional jet tube, but with one or two fewer apertures per row than the conventional jet tube. For example, where a conventional jet tube has a number of apertures (**N**) that are arranged in a number of rows (**R**), jet tube **200** may have **N-R** apertures arranged in **R** rows or **N-2R** apertures arranged in **R** rows.

FIG. **9** illustrates an embodiment of a jet veneer dryer system **300**, in accordance with various embodiments.

System **300** may include a frame **346**, a conveyor system with paired upper and lower rollers **342a**, **342b**, and self-cleaning jet tubes **302a**, **302b**. System **300** may also include one or more of a fan **340**, a heater **332**, a plenum space **336**, and/or a computer system **338**. In some embodiments, computer system **338** may be configured to control various operations of heater **332**, fan **340**, rollers **342a**, **342b**, and/or other components of system **300**.

Frame **346** may have a proximal end, a distal end, and generally opposite first and second sides. Rollers **342a**, **342b** may be coupled at a first end with the first side of frame **346** and coupled at an opposite second end with the second side of frame **346**. Thus, rollers **342a**, **342b** may extend transverse to a path of flow that extends through the frame between the rollers. Rollers **342a**, **342b** may be rotatable in opposite rotary directions to convey a piece of veneer **334** along the flow path through frame **346**.

Jet tubes **302a**, **302b** may be generally as described herein with reference to jet tubes **100** and/or **200**. For example, jet tubes **302a**, **302b** may be substantially rectangular in cross section and tapered from an open first end to a generally closed second end, each with upper and lower surfaces, a plurality of apertures in one of the surfaces, and one or more through-slots **324**. Optionally, the length of the through-slot(s) may be at least twice the width. In some embodiments, one or more through-slots **324** may be disposed along a bottom half of each jet tube (e.g., below a longitudinal center axis of the jet tube). Another one or more through-slots **324** may be disposed along an upper half of each jet tube (e.g., above a longitudinal center axis of the jet tube). Some or all of the through-slots **324** may be positioned at or near the second end **306**.

Jet tubes **302a**, **302b** may have a generally open first end **304** with a flange **316** and a generally opposite second end **306**. First end **304** may be mounted to the first side of frame **346** with flange **316** positioned to block or reduce airflow between frame **346** and the corresponding jet tube **302a/**

302b. Second end **306** may be mounted to the second side of frame **346**. Jet tube **302a** may be mounted to frame **346** above the flow path in a top-side-down orientation, and jet tube **302b** may be mounted to frame **346** below the flow path in a top-side-up orientation. Jet tubes **302a**, **302b** may be positioned between adjacent pairs of rollers **342a**, **342b** and oriented generally transverse to the path of flow.

In operation, air may be circulated to heater **332** and from heater **332** to input plenum **336** by one or more fans **340**. The fan(s) **340** may be configured to direct heated air to the input plenum **336** which may result in an increased air pressure within input plenum **336**. The heated air may flow from input plenum **336** into the open first ends **304** of the jet tubes **302a**, **302b**. The heated air may then exit the jet tubes through the apertures. Debris **348** may be carried by the heated air into the jet tubes **302a**, **302b** and toward the second ends **306** to one or more of the through-slots **324**. The debris **348** may be pushed into and through one or more of the through-slots **324** to exit the jet tube **302a** or **302b**.

FIG. **10** illustrates a method of forming a self-cleaning jet tube, in accordance with various embodiments

In various embodiments, method **400** may begin at block **401**. At block **401**, an elongate hollow body (e.g., elongate hollow body **102/202**) may be provided. The elongate hollow body may have an open first end (e.g., first end **104** or **204**), a second end (e.g., second end **106** or **206**) generally opposite the first end, a plurality of longitudinal walls (e.g., upper wall **110** or **210**, lower wall **112** or **212**, side walls **114a**, **114b** or **214a**, **214**), and an end wall (e.g., end plate **120** or **220**) disposed generally between the longitudinal walls at the second end. The elongate hollow body may also have a plurality of apertures (e.g., apertures **108** or **208**) in one of the longitudinal walls.

In some embodiments, providing the elongate hollow body may include constructing one or more sections of the elongate hollow body from one or more pieces of metal. Some or all of the sections may be coupled together at block **401**. Alternatively, one of the sections may be coupled to another of the sections at block **403** or thereafter. In other embodiments, the elongate hollow body may be an existing jet tube (e.g., a conventional jet tube) or some portion thereof.

At block **403**, at least one through-slot (e.g., through-slot **124** or **224**) may be formed through one or more of the walls. The through-slot(s) may have a width and a length that is at least twice the width.

In some embodiments, the through-slot(s) may be formed in an existing jet tube by using a cutting device (e.g., a laser/plasma cutting device, a cutting blade, a grinder, a cutting torch, etc.).

In other embodiments, the through-slot(s) may be formed in an existing jet tube by removing a portion of the existing jet tube, such as an end plate or a wall section, forming a recess (e.g., recess **130** or **230**) or through-slot in the removed portion or a replacement portion, and coupling the removed/replacement portion with the remaining portion of the existing jet tube. Again, the through-slot(s) may be formed through one plate/wall, between the end plate and a wall, and/or between adjacent walls. In some embodiments, the through-slot(s) may be formed along or near the upper wall, the lower wall, or both.

Optionally, at block **405** one or more of the apertures may be blocked. Blocking one or more of the apertures may at least partially offset the loss of air through the through-slot(s), which may help to maintain a desired air pressure at the remaining apertures. In some embodiments, the apertures nearest to the second end may be blocked. For example, if

the apertures are arranged in three rows that extend longitudinally from the first end to the second end, the end-most aperture in each row may be blocked.

Blocking the aperture(s) may involve welding a metal plate over the aperture(s), replacing a portion of the wall with a plate that has fewer or no apertures, or any other suitable technique. In some embodiments block 405 may be omitted.

Alternatively, in some embodiments the through-slot(s) may be formed before or during construction of the elongate hollow body. For example, a through-slot may be formed in one or more components of the jet tube before coupling some or all of the components together. An example of such an embodiment is illustrated in FIG. 11.

Referring now to FIG. 11, method 500 may begin at block 501. At block 501, one or more sections of an elongate hollow tube may be formed from one or more pieces of metal. The section(s) may be configured to be coupled together to form an elongate hollow tube that is generally rectangular in cross-section and tapered from a generally open first end to a second end. In some embodiments, the one or more pieces of metal may be sheets of metal, and two or more sections may be formed (e.g., cut and/or shaped) from the sheets of metal. Optionally, apertures (e.g., apertures 108 or 208) may be formed in one of the sections at block 501.

At block 503, an end plate (e.g., end plate 120 or 220) may be formed. The end plate may be formed, for example, by cutting or shaping a separate piece of metal to fit the opening at the second end of the elongate hollow body. Alternatively, the end plate may be formed by bending an end of one or more of the sections such that the end(s) will be oriented transverse to the longitudinal walls in the assembled jet tube.

At block 505, at least a portion of a first through-slot may be formed in the end plate or in one of the sections. Alternatively, the first through-slot or a portion thereof may be formed in the one or more pieces of metal at block 505, and method 500 may begin at block 505 before proceeding to block 501. In some embodiments, forming at least a portion of the first through-slot may include forming a recess (e.g., recess 130) in an outer edge of any of the above components. The recess may be positioned such that formation of the first through-slot (e.g., between two sections or between an end wall and a section) can be completed by coupling the sections and/or end plate together.

In other embodiments, the entire through-slot may be formed at block 505 by removing a corresponding portion of material (e.g., by cutting) from any one of the components. Optionally, the aperture or first through-slot may be positioned such that the first through-slot will be disposed along or proximal to an upper or lower longitudinal wall of the assembled jet tube.

At block 507, the end plate may be coupled to one or more of the walls at the second end of the elongate hollow tube. In some embodiments, the end plate and one of the sections may be coupled together before adding the other section(s), if any. In other embodiments, some or all of the sections may be coupled together before adding the end plate.

Various operations are described above as multiple discrete actions or operations in turn, for the purpose of clarity and to aid explanation of the subject matter. However, the operations are not necessarily order dependent. In particular, any or all of the operations may be performed in a different order than in the described embodiments. Additional operations may be performed in some embodiments, and one or more of the operations may be omitted in other embodiments.

In accordance with various embodiments, self-cleaning jet tubes with one or more through-slots may provide an opportunity to extend operating/production time between dryer cleaning outages. For example, in regions with relatively low fiber moisture, jet tubes experience comparatively more acute fiber accumulation (e.g., North American west coast and cold climates), the use of such self-cleaning jet tubes may increase production by 20-30 shifts annually.

In addition, self-cleaning jet tubes may significantly reduce overhead costs by reducing or eliminating the need to staff 20-30 shifts annually with 4-6 man cleaning crews. Such jet tubes may also reduce the loss production that is typically experienced during the last shifts prior to cleaning as a result of fiber accumulation in the narrow ends of the jet tubes.

Although certain embodiments have been illustrated and described herein, it will be appreciated by those of ordinary skill in the art that a wide variety of alternate and/or equivalent embodiments or implementations calculated to achieve the same purposes may be substituted for the embodiments shown and described without departing from the scope. Those with skill in the art will readily appreciate that embodiments may be implemented in a very wide variety of ways. This application is intended to cover any adaptations or variations of the embodiments discussed herein. Therefore, it is manifestly intended that embodiments be limited only by the claims and the equivalents thereof.

What is claimed is:

1. A jet tube for use in a veneer dryer, the jet tube comprising:

an elongate hollow body that is tapered from an open first end to a generally opposite second end, the elongate hollow body having an upper wall with a plurality of apertures, a lower wall, side walls, a longitudinal center axis, and an end plate at the second end, wherein the end plate is disposed generally between the walls and oriented transverse to the longitudinal center axis and the walls; and

a first through-slot disposed at the second end, wherein a first portion of the first through-slots is defined by the end plate, and a second portion of the first through-slot is defined by one of the walls, such that the first through-slot extends through the end plate or through said one of the walls.

2. The jet tube of claim 1, wherein the first through-slot is generally oblong in shape.

3. The jet tube of claim 1, wherein the first through-slot has a length and a width, and the length is at least twice the width.

4. The jet tube of claim 1, wherein the end plate has an outer edge portion that defines a recess, and the first portion of the first through-slot is formed by said outer edge portion, such that the first through-slot extends through the end plate.

5. The jet tube of claim 1, wherein the first through-slot is $\frac{1}{16}$ " to $\frac{5}{16}$ " in width and $\frac{3}{8}$ " to $\frac{7}{8}$ " in length.

6. The jet tube of claim 1, wherein said one of the walls has an outer edge portion that defines a recess, and the second portion of the first through-slot is formed by said outer edge portion, such that the first through-slot extends through said one of the walls.

7. The jet tube of claim 5, wherein the first through-slot is $\frac{1}{8}$ " to $\frac{1}{4}$ " in width and $\frac{1}{2}$ " to $\frac{3}{4}$ " in length.

8. The jet tube of claim 1, wherein said one of the walls is the upper wall or the lower wall.

9. The jet tube of claim 1, further including a second through-slot, wherein one of said through-slots is disposed

13

between the end plate and the upper wall, and the other of said through-slots is disposed between the end plate and the lower wall.

10. The jet tube of claim 9, wherein the apertures are arranged longitudinally along the upper wall in one or more rows, and at least one of the through-slots is positioned in alignment with a first one of the one or more rows.

11. The jet tube of claim 1, further including a second through-slot, wherein at least one of the through-slots is disposed between the end plate and one of the side walls.

12. The jet tube of claim 1, further including additional through-slots, wherein the first through-slot and one or more of the additional through-slots are disposed between the end plate and the upper wall and another one or more of the additional through-slots are disposed between the end plate and the lower wall.

13. A jet tube for use in a veneer dryer, the jet tube comprising:

an elongate hollow body that is tapered from an open first end to a generally opposite second end, the elongate hollow body having an upper wall with a plurality of apertures, a lower wall, generally opposite side walls, a longitudinal center axis, and an end plate disposed at the second end, wherein the end plate is positioned generally between the walls and oriented transverse to the longitudinal center axis and the walls; and

a first through-slot disposed through the end plate or at least one of the walls, wherein the jet tube is configured to maintain a veneer drying air pressure at the apertures with the first through-slot unblocked to thereby evacuate debris through the first through-slot while directing air against a sheet of veneer.

14. The jet tube of claim 13, wherein at least a portion of the first through-slot is disposed through the upper wall or the lower wall of the elongate hollow body at or near the second end.

15. The jet tube of claim 13, wherein the length of the opening defined by the first through-slot is at least twice the width of the opening.

16. The jet tube of claim 13, wherein the first through-slot is $\frac{1}{8}$ " to $\frac{1}{4}$ " in width and $\frac{1}{2}$ " to $\frac{3}{4}$ " in length.

17. The jet tube of claim 13, wherein a first portion of the first through-slot is defined by one or more of the walls and a second portion of the first through-slot is defined by the end plate.

18. The jet tube of claim 17, wherein the end plate or at least one of the walls has an outer edge that defines a recess, and the first through-slot is at least partially defined by the recess.

19. The jet tube of claim 18, wherein the recess is $\frac{1}{8}$ " to $\frac{1}{4}$ " in width and $\frac{1}{2}$ " to $\frac{3}{4}$ " in length.

20. The jet tube of claim 13, further including one or more additional through-slots, wherein at least some of the apertures are arranged longitudinally in a row along the upper wall and the first through-slot is substantially aligned with the row.

21. The jet tube of claim 20, wherein the first through-slot is disposed proximal to an intersection of the end plate and

14

the upper wall, and at least one of the additional through-slots is disposed proximal to an intersection of the end plate and the lower wall.

22. A method of forming a self-cleaning jet tube for use in a jet veneer dryer, the method comprising:

providing an elongate hollow body that is tapered from an open first end to a generally opposite second end, wherein the elongate hollow body has a plurality of longitudinal walls, a plurality of apertures along one of the longitudinal walls, and an end wall disposed at the second end, wherein the end wall is transverse to the longitudinal walls; and

forming a first through-slot through at least one of the walls of the elongate hollow body,

wherein the first through-slots defines an opening at or near the second end, and the opening is $\frac{1}{16}$ " to $\frac{5}{16}$ " wide and $\frac{3}{8}$ " to $\frac{7}{8}$ " long.

23. The method of claim 22, wherein the elongate hollow body is an existing jet tube, and forming the first through-slot includes removing a portion of material from the elongate hollow body.

24. The method of claim 22, wherein forming the first through-slot includes forming a recess in a plate member, and providing the elongate hollow body includes coupling the plate member to the longitudinal walls at the second end to form the end wall, such that the first through-slot is at least partially defined by the recess.

25. The method of claim 22, wherein the elongate hollow body has a plurality of apertures arranged along a first one of the longitudinal walls, and the first through-slot is disposed along or proximal to the first one of the longitudinal walls.

26. The method of claim 22, wherein providing the elongate hollow body includes forming the longitudinal walls from one or more pieces of metal, forming an end plate, and coupling the end plate to one or more of the longitudinal walls to form the end wall.

27. The method of claim 26, wherein forming the first through-slot includes forming a recess in an edge of the end plate before coupling the end plate to the one or more of the longitudinal walls, such that the first through-slot is at least partially defined by the recess.

28. The method of claim 26, wherein forming the first through-slot includes forming a recess in an edge of the one or more pieces of metal before coupling the end plate to the one or more of the longitudinal walls, such that the first through-slot is at least partially defined by the recess.

29. The method of claim 26, wherein forming the first through-slot includes forming the first through-slot through the end plate or the one or more pieces of metal before coupling the end plate to the one or more of the longitudinal walls.

30. The method of claim 22, wherein the length of the opening defined by the first through-slot is at least twice the width of the opening.

* * * * *