



US009465194B2

(12) **United States Patent**
Jo

(10) **Patent No.:** **US 9,465,194 B2**
(45) **Date of Patent:** **Oct. 11, 2016**

(54) **OPTICAL SYSTEM**

(71) Applicant: **SAMSUNG ELECTRO-MECHANICS CO., LTD.**, Suwon-Si (KR)

(72) Inventor: **Yong Joo Jo**, Suwon-Si (KR)

(73) Assignee: **Samsung Electro-Mechanics Co., Ltd.**, Suwon-si (KR)

(*) Notice: Subject to any disclaimer, the term of this patent is extended or adjusted under 35 U.S.C. 154(b) by 0 days.

(21) Appl. No.: **14/644,737**

(22) Filed: **Mar. 11, 2015**

(65) **Prior Publication Data**

US 2016/0065812 A1 Mar. 3, 2016

(30) **Foreign Application Priority Data**

Sep. 2, 2014 (KR) 10-2014-0116392

(51) **Int. Cl.**
G02B 9/60 (2006.01)
H04N 5/225 (2006.01)
G02B 13/00 (2006.01)

(52) **U.S. Cl.**
CPC **G02B 9/60** (2013.01); **G02B 13/0045** (2013.01); **H04N 5/2254** (2013.01)

(58) **Field of Classification Search**
CPC G02B 9/60; G02B 9/62; G02B 9/64; G02B 13/0045
USPC 359/714, 713, 753, 754, 755, 756
See application file for complete search history.

(56) **References Cited**

U.S. PATENT DOCUMENTS

2014/0029116 A1* 1/2014 Tsai G02B 13/0045 359/714
2014/0085735 A1* 3/2014 Shih G02B 13/0045 359/714
2015/0036045 A1 2/2015 Hsu et al.

FOREIGN PATENT DOCUMENTS

JP 2014-66993 A 4/2014
TW 201411181 A 3/2014

OTHER PUBLICATIONS

Korean Office Action issued on Jan. 1, 2016 in counterpart Korean Patent Application No. 10-2014-0116392 (8 pages in English; 6 pages in Korean).

* cited by examiner

Primary Examiner — Scott J Sugarman
Assistant Examiner — Alberto Betancourt
(74) *Attorney, Agent, or Firm* — NSIP Law

(57) **ABSTRACT**

An optical system includes a first lens having negative refractive power, of which an object-side surface is convex, a second lens having positive refractive power, a third lens having negative refractive power, of which an object-side surface is concave, a fourth lens having positive refractive power, of which an image-side surface is convex, and a fifth lens having negative refractive power and having a meniscus shape in which an object-side surface thereof is convex. The first to fifth lenses are sequentially disposed from an object side. An aberration improvement effect may be increased and high resolution and a wide angle may be implemented.

28 Claims, 12 Drawing Sheets

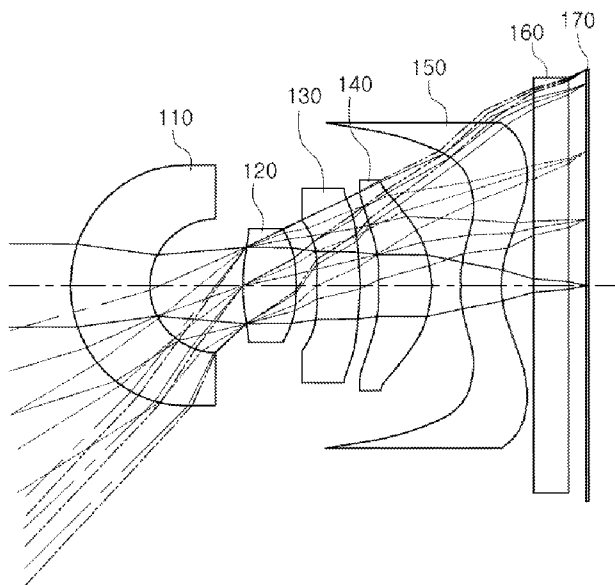

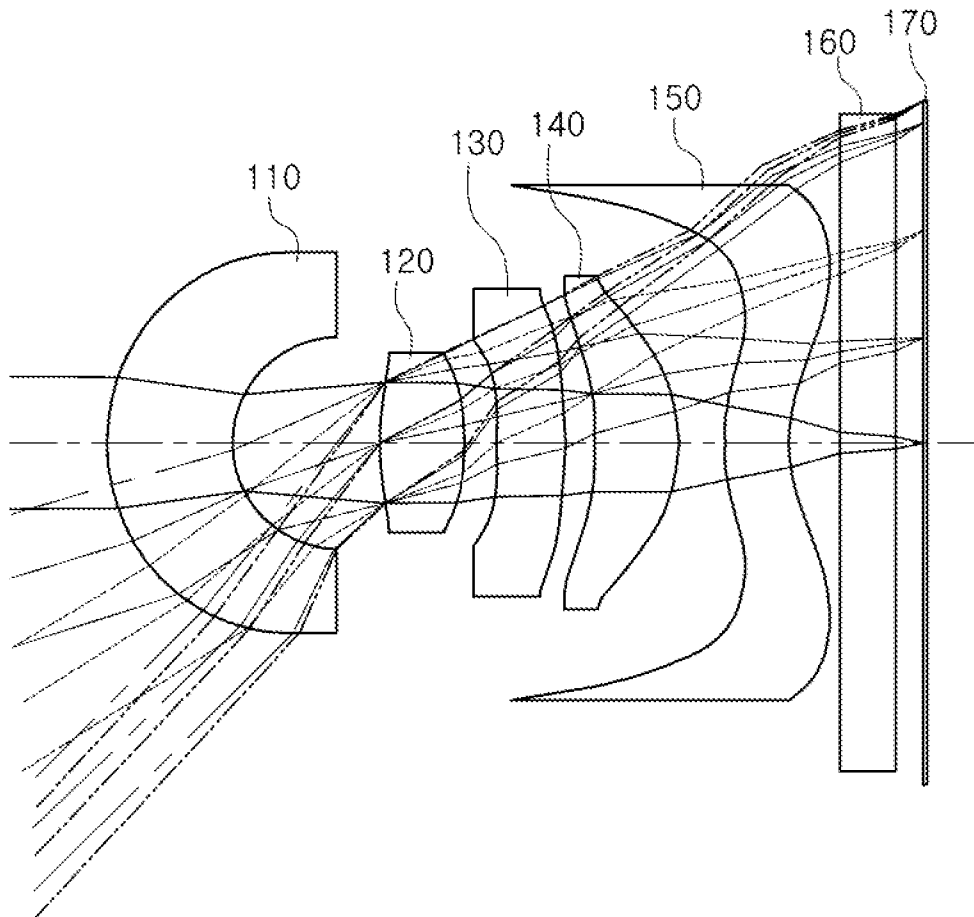

FIG. 1

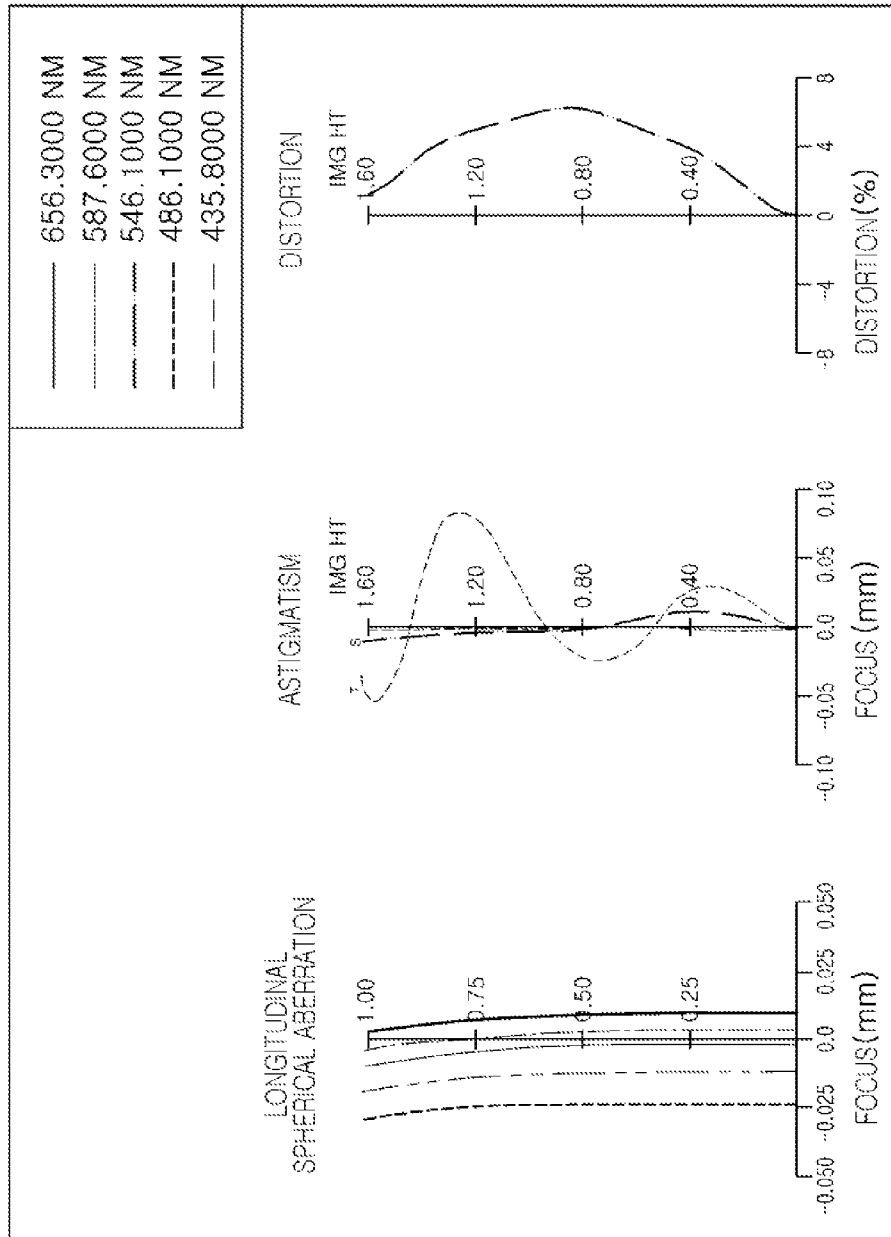

FIG. 2

Surface	Radius	Thickness	index	abbe
object	Infinity	Infinity		
1	Infinity	0.058983		
2	0.89623	0.58977	1.651	22
3	0.50588	0.703559		
4	1.6871	0.394181	1.5441	55
5	-1.51006	0.152747		
6	-6.05439	0.314795	1.651	22
7	-6.64308	0.14638		
8	-1.26325	0.390511	1.5441	55
9	-0.6236	0.222261		
10	1.04931	0.288979	1.5441	55
11	0.68449	0.250321		
12	Infinity	0.247727	1.517	64.2
13	Infinity	0.138998		
Image	Infinity	0.001293		

FIG. 3

surface#	2	3	4	5	6	7	8	9	10	11
Conic Constant (K)	0	0	-5.36767	5.46068	146.8408	0	1.344274	-0.69426	-0.79689	-2.79232
4th Order Coefficient (A)	0.00836	-0.10744	-0.0486	-1.04237	-1.97676	-0.95849	0.798248	0.948816	-0.75011	-0.47709
6th Order Coefficient (B)	-0.03024	1.75506	-0.77564	1.12735	3.96447	2.06925	-3.71444	-3.23699	0.15625	0.467742
8th Order Coefficient (C)	0.200043	-3.33883	-7.20967	-12.1177	-21.4173	-5.11115	6.40355	7.9134	-0.51851	0.523226
10th Order Coefficient (D)	-0.1754	-8.80711	-35.2477	35.0495	68.8301	17.1294	0.907119	-13.478	1.18968	0.32902
12th Order Coefficient (E)	0	0	237.314	-135.315	-111.193	-32.608	-21.5273	15.4029	-1.02029	-0.09023
14th Order Coefficient (F)	0	0	-794.332	-16.1763	80.7219	22.7294	20.9226	-5.73243	0.25553	0.002935

FIG. 4

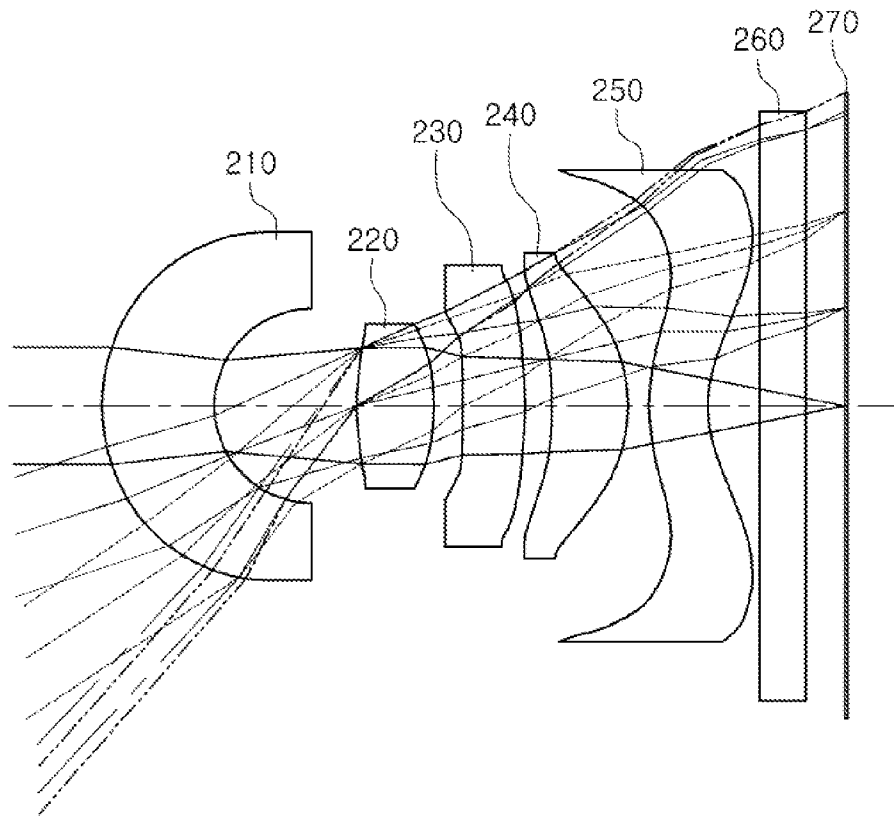

FIG. 5

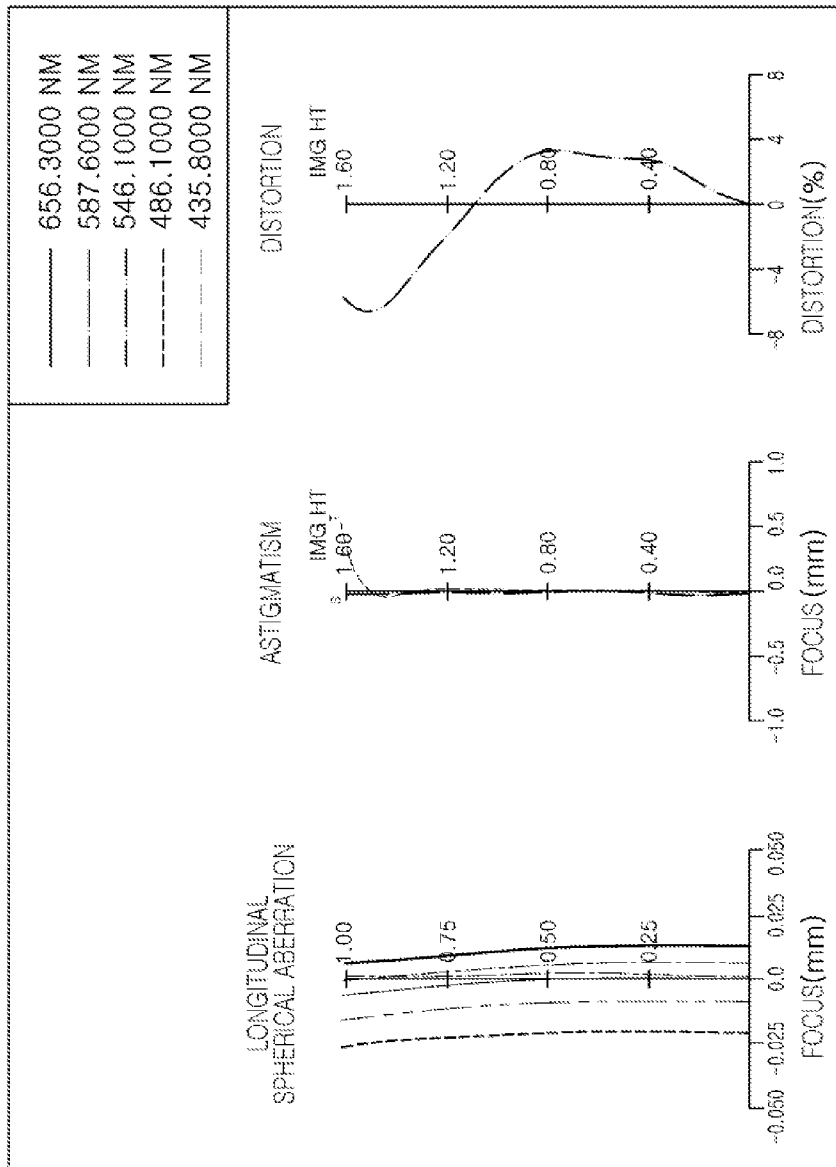

FIG. 6

Surface object	Radius	Thickness	index	abbe
1	Infinity	0.058983		
2	0.89411	0.591189	1.651	22
3	0.50357	0.73254		
4	1.67107	0.39363	1.5441	55
5	-1.52589	0.155306		
6	-10	0.311434	1.651	22
7	-12.28596	0.144267		
8	-1.26408	0.391234	1.5441	55
9	-0.62415	0.112651		
10	0.94263	0.301976	1.5441	55
11	0.61961	0.250321		
12	Infinity	0.247727	1.517	64.2
13	Infinity	0.212007		
Image	Infinity	-0.000867		

FIG. 7

surface#	2	3	4	5	6	7	8	9	10	11
Conic Constant (K)	0	0	-5.42962	5.411621	174.2131	0	1.347307	-0.69578	-0.78249	-2.92405
4th Order Coefficient (A)	0.009547	-0.11689	-0.04981	-1.04704	-1.97944	-0.95276	0.796438	0.950302	-0.75286	-0.44925
6th Order Coefficient (B)	-0.03187	1.76926	-0.75598	1.15728	3.8299	2.07925	-3.71796	-3.23468	0.193079	0.475827
8th Order Coefficient (C)	0.196775	-3.17545	-7.18113	-11.5685	-21.5731	-5.09196	8.33697	7.92215	-0.47737	-0.52629
10th Order Coefficient (D)	-0.17996	-7.79938	-35.6211	40.4032	68.2832	17.16	0.897241	-13.4716	1.21809	0.325162
12th Order Coefficient (E)	0	0	237.314	-135.315	-111.193	-32.608	-21.5273	15.4029	-1.02029	-0.09045
14th Order Coefficient (F)	0	0	-794.332	-16.1763	80.7219	22.7294	20.9228	-5.79243	0.25553	-0.00294

FIG. 8

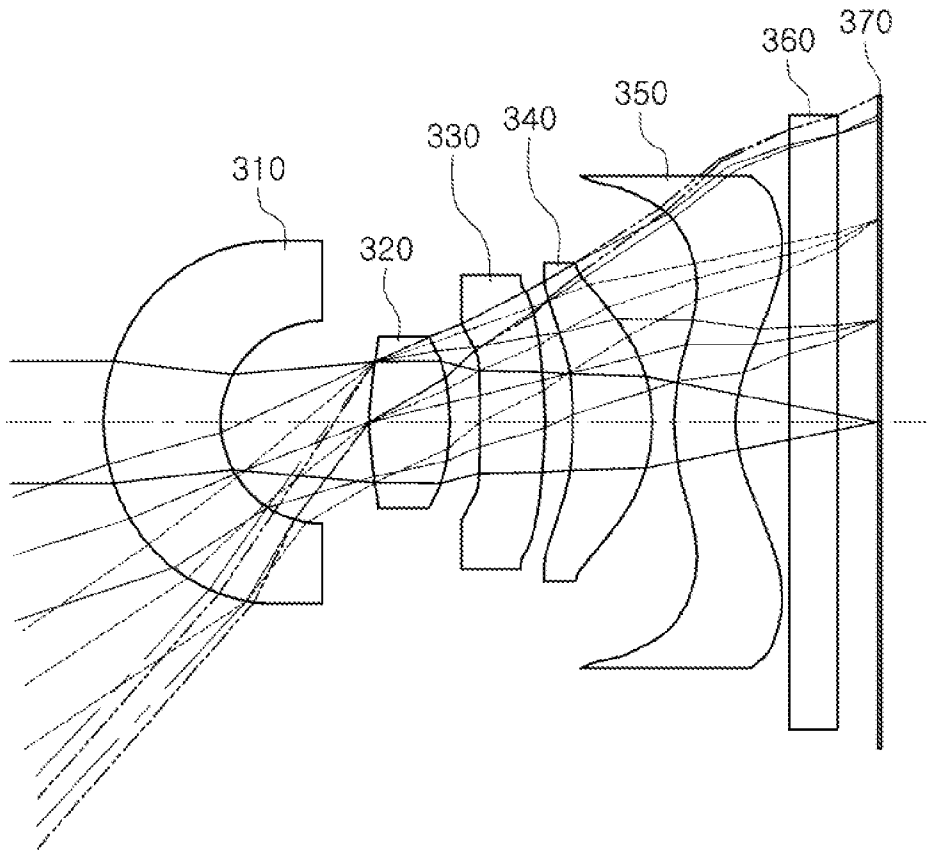

FIG. 9

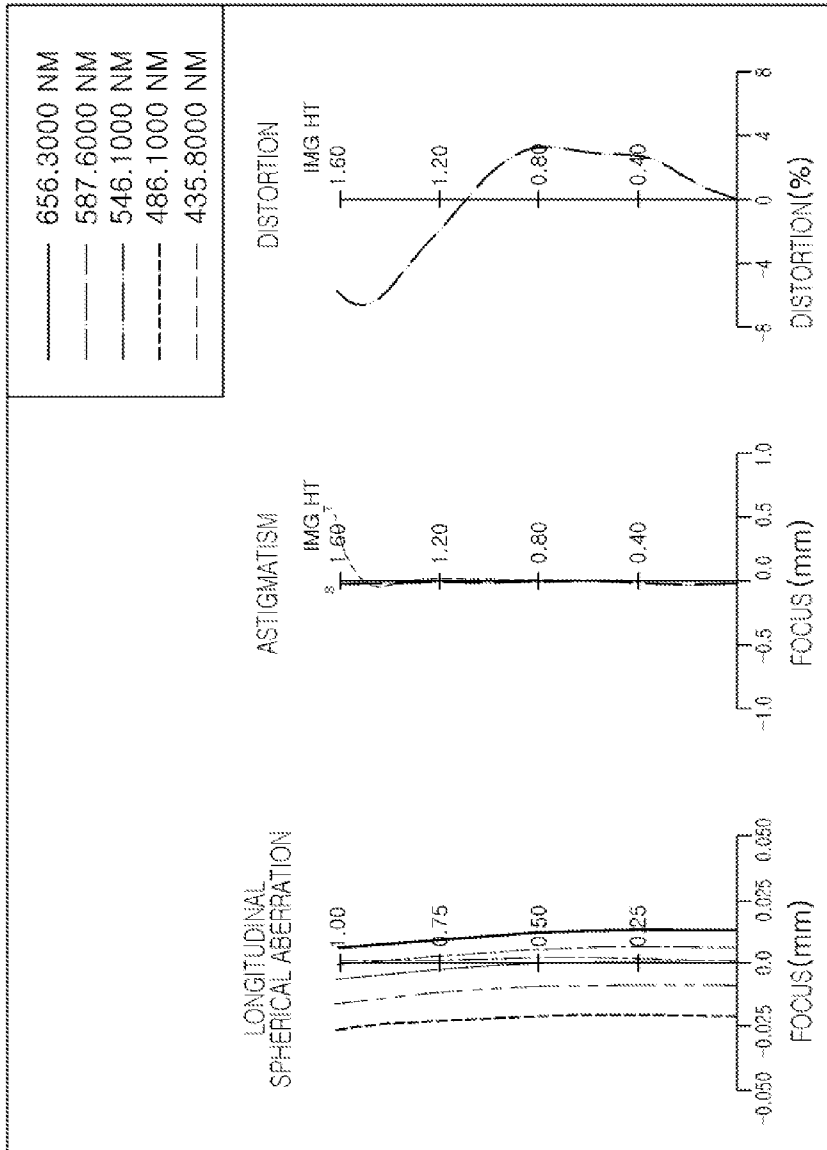

FIG. 10

Surface object	Radius	Thickness	index	abbe
1	Infinity	0.058983		
2	0.89423	0.591135	1.651	22
3	0.5035	0.733841		
4	1.66753	0.393604	1.5441	55
5	-1.52858	0.155197		
6	-20	0.310929	1.651	22
7	-32.20727	0.143494		
8	-1.26409	0.392143	1.5441	55
9	-0.62446	0.113167		
10	0.94239	0.302491	1.5441	55
11	0.61953	0.250321		
12	Infinity	0.247727	1.517	64.2
13	Infinity	0.204274		
Image	Infinity	-0.00106		

FIG. 11

surface#	2	3	4	5	6	7	8	9	10	11
Conic Constant (K)	0	0	-5.45943	5.421763	139.0984	0	1.347617	-0.69624	-0.78462	-2.9381
4th Order Coefficient (A)	0.009553	-0.11698	-0.05056	-1.04809	-1.97882	-0.95294	0.79602	0.950955	-0.75351	-0.44826
6th Order Coefficient (B)	-0.09197	1.77093	-0.76977	1.15441	3.93192	2.07883	-3.7182	-3.23408	0.193256	0.476514
8th Order Coefficient (C)	0.196593	-3.16526	-7.38661	-11.5667	-21.5672	-5.09283	8.39686	7.92275	-0.47633	-0.52627
10th Order Coefficient (D)	-0.18022	-7.75154	-38.4471	40.5026	68.3028	17.158	0.897357	-13.4709	1.21992	0.326039
12th Order Coefficient (E)	0	0	237.314	-135.315	-111.193	-32.608	-21.5273	15.4029	-1.02029	-0.09053
14th Order Coefficient (F)	0	0	-794.332	-16.1763	80.7219	22.7294	20.9226	-5.73243	0.25553	-0.00293

FIG. 12

1

OPTICAL SYSTEM

CROSS-REFERENCE TO RELATED APPLICATION

This application claims the priority and benefit of Korean Patent Application No. 10-2014-0116392 filed on Sep. 2, 2014, with the Korean Intellectual Property Office, the disclosure of which is incorporated herein by reference.

BACKGROUND

The present disclosure relates to an optical system.

Recent mobile communications terminals have commonly been provided with camera modules, allowing users to make video calls, as well as to capture still and moving images. In addition, as the degree of functionality of camera modules included in mobile communications terminals has gradually increased, camera modules for mobile communications terminals have come to be required to have high levels of resolution and high degrees of performance.

However, since there is a trend for mobile communications terminals to be miniaturized and lightened, there are limitations in implementing camera modules having the high levels of resolution and high degrees of performance.

In order to solve these problems, recently, lenses included in such camera modules have been formed of plastic, a material lighter than glass, and lens modules have been configured with five or more lenses, in order to implement high levels of resolution in images captured thereby.

SUMMARY

An aspect of the present disclosure may provide an optical system capable of improving an aberration improvement effect, implementing high resolution, and implementing a wide field of view.

According to an aspect of the present disclosure, an optical system may include: a first lens having negative refractive power, of which an object-side surface is convex, a second lens having positive refractive power, a third lens having negative refractive power, of which an object-side surface is concave, a fourth lens having positive refractive power, of which an image-side surface is convex, and a fifth lens having negative refractive power and having a meniscus shape in which an object-side surface of the fifth lens is convex, wherein the first to fifth lenses are sequentially disposed from an object side, whereby an aberration improvement effect may be increased and high resolution and a wide angle may be implemented.

BRIEF DESCRIPTION OF DRAWINGS

The above and other aspects, features and other advantages of the present disclosure will be more clearly understood from the following detailed description taken in conjunction with the accompanying drawings, in which:

FIG. 1 is a configuration diagram of an optical system according to a first exemplary embodiment of the present disclosure;

FIG. 2 is a curve showing aberration characteristics of the optical system shown in FIG. 1;

FIG. 3 is a table showing characteristics of each lens of the optical system shown in FIG. 1;

FIG. 4 is a table showing aspherical surface coefficients of each lens of the optical system shown in FIG. 1;

2

FIG. 5 is a configuration diagram of an optical system according to a second exemplary embodiment of the present disclosure;

FIG. 6 is a curve showing aberration characteristics of the optical system shown in FIG. 5;

FIG. 7 is a table showing characteristics of each lens of the optical system shown in FIG. 5;

FIG. 8 is a table showing aspherical surface coefficients of each lens of the optical system shown in FIG. 5;

FIG. 9 is a configuration diagram of an optical system according to a third exemplary embodiment of the present disclosure;

FIG. 10 is a curve showing aberration characteristics of the optical system shown in FIG. 9;

FIG. 11 is a table showing characteristics of each lens of the optical system shown in FIG. 9; and

FIG. 12 is a table showing aspherical surface coefficients of each lens of the optical system shown in FIG. 9.

DETAILED DESCRIPTION

Exemplary embodiments of the present disclosure will now be described in detail with reference to the accompanying drawings.

The disclosure may, however, be embodied in many different forms and should not be construed as being limited to the embodiments set forth herein. Rather, these embodiments are provided so that this disclosure will be thorough and complete, and will fully convey the scope of the disclosure to those skilled in the art.

In the drawings, the shapes and dimensions of elements may be exaggerated for clarity, and the same reference numerals will be used throughout to designate the same or like elements.

In the following lens configuration diagrams, thicknesses, sizes, and shapes of lenses have been slightly exaggerated for explanation. Particularly, a shape of a spherical surface or an aspherical surface shown in the lens configuration diagrams has been shown only by way of example. For example, the spherical surface or the aspherical surface is not limited to having the shown shape.

In addition, it is to be noted that a first lens refers to a lens that is the closest to an object side, and a fifth lens refers to a lens that is the closest to an image side.

Further, it is to be noted that the term 'front' refers to a direction from the optical system toward the object side, while the term 'rear' refers to a direction from the optical system toward an image sensor or the image side. Further, it is to be noted that a first surface of each lens refers to a surface close to the object side (or an object-side surface) and a second surface of each lens refers to a surface close to the image side (or an image-side surface). Further, in the present specification, it is to be noted that units of all of numerical values of radii of curvature, thicknesses, and the like, of lenses are taken in millimeters (mm).

An optical system according to an exemplary embodiment of the present disclosure may include five lenses.

For example, the optical system according to an exemplary embodiment of the present disclosure may include a first lens, a second lens, a third lens, a fourth lens, and a fifth lens.

However, the optical system according to an exemplary embodiment of the present disclosure is not limited to including only the five lenses, but may further include other components, if necessary. For example, the optical system may include an aperture stop controlling an amount of light. In addition, the optical system may further include an

infrared cut-off filter cutting off an infrared ray. Further, the optical system may further include an image sensor converting an image of a subject incident thereto into an electrical signal. Further, the optical system may further include a gap maintaining member adjusting a gap between lenses.

The first to fifth lenses configuring the optical system according to an exemplary embodiment of the present disclosure may be formed of plastic.

In addition, at least one of the first to fifth lenses may have an aspherical surface. Further, each of the first to fifth lenses may have at least one aspherical surface.

Here, the aspherical surfaces of the first to fifth lenses may be represented by Mathematical Expression 1.

[Mathematical Expression 1]

$$Z = \frac{cY^2}{1 + \sqrt{1 - (1 + K)c^2 Y^2}} + AY^4 + BY^6 + CY^8 + DY^{10} + EY^{12} + FY^{14} + \dots$$

Here, c is a curvature (inverse number of a radius of curvature) at an apex of the lens, K is a Conic constant, and Y is a distance in a direction perpendicular to an optical axis. In addition, constants A to F mean aspherical surface coefficients. In addition, Z indicates a distance from the apex of the lens in an optical axis direction.

The optical system including the first to fifth lenses may have negative refractive power/positive refractive power/negative refractive power/positive refractive power/negative refractive power sequentially from the object side.

The optical system configured as described above may implement a wide angle through widening of a field of view and improve optical performance through aberration improvement.

The optical system according to an exemplary embodiment of the present disclosure may satisfy Conditional Expression 1.

$$FOV \geq 80 \quad \text{[Conditional Expression 1]}$$

Here, FOV is a field of view of the optical system.

The optical system according to an exemplary embodiment of the present disclosure may satisfy Conditional Expression 2.

$$FOV/TTL > 20 \quad \text{[Conditional Expression 2]}$$

Here, FOV is the field of view of the optical system, and TTL is a distance from an object-side surface of the first lens to an imaging surface.

The optical system according to an exemplary embodiment of the present disclosure may satisfy Conditional Expression 3.

$$TTL/F < 2.7 \quad \text{[Conditional Expression 3]}$$

Here, TTL is the distance from the object-side surface of the first lens to the imaging surface, and F is an overall focal length of the optical system.

The optical system according to an exemplary embodiment of the present disclosure may satisfy Conditional Expression 4.

$$-3 < F1/F < -1 \quad \text{[Conditional Expression 4]}$$

Here, F1 is a focal length of the first lens, and F is the overall focal length of the optical system.

The optical system according to an exemplary embodiment of the present disclosure may satisfy Conditional Expression 5.

$$0.8 < F2/F < 1.1 \quad \text{[Conditional Expression 5]}$$

Here, F2 is a focal length of the second lens, and F is the overall focal length of the optical system.

The optical system according to an exemplary embodiment of the present disclosure may satisfy Conditional Expression 6.

$$-90 < F3/F < -55 \quad \text{[Conditional Expression 6]}$$

Here, F3 is a focal length of the third lens, and F is the overall focal length of the optical system.

The optical system according to an exemplary embodiment of the present disclosure may satisfy Conditional Expression 7.

$$1.0 < F4/F < 1.3 \quad \text{[Conditional Expression 7]}$$

Here, F4 is a focal length of the fourth lens, and F is the overall focal length of the optical system.

The optical system according to an exemplary embodiment of the present disclosure may satisfy Conditional Expression 8.

$$-3.4 < F5/F < -3.0 \quad \text{[Conditional Expression 8]}$$

Here, F5 is a focal length of the fifth lens, and F is the overall focal length of the optical system.

Next, the first to fifth lenses configuring the optical system according to an exemplary embodiment of the present disclosure will be described.

Shapes of each lens to be described below may be shapes in a paraxial region.

The first lens may have negative refractive power. In addition, the first lens may have a meniscus shape in which it is convex toward an object. In detail, first and second surfaces of the first lens may be convex toward the object.

At least one of the first and second surfaces of the first lens may be aspherical. For example, both surfaces of the first lens may be aspherical.

The second lens may have positive refractive power. In addition, both surfaces of the second lens may be convex.

At least one of first and second surfaces of the second lens may be aspherical. For example, both surfaces of the second lens may be aspherical.

The third lens may have negative refractive power. In addition, the third lens may have a meniscus shape in which it is convex toward an image. In detail, first and second surfaces of the third lens may be convex toward the image.

At least one of the first and second surfaces of the third lens may be aspherical. For example, both surfaces of the third lens may be aspherical.

The fourth lens may have positive refractive power. In addition, the fourth lens may have a meniscus shape in which it is convex toward the image. In detail, a first surface of the fourth lens may be concave toward the object, and a second surface thereof may be convex toward the image.

At least one of the first and second surfaces of the fourth lens may be aspherical. For example, both surfaces of the fourth lens may be aspherical.

The fifth lens may have negative refractive power. In addition, the fifth lens may have a meniscus shape in which it is convex toward the object. In detail, first and second surfaces of the fifth lens may be convex toward the object.

At least one of the first and second surfaces of the fifth lens may be aspherical. For example, both surfaces of the fifth lens may be aspherical.

In addition, the fifth lens may have at least one inflection point formed on the first surface thereof, and also have at least one inflection point formed on the second surface

5

thereof. For example, the second surface of the fifth lens may be concave in the paraxial region and become convex toward an edge thereof.

In the optical system configured as described above, a plurality of lenses perform an aberration correction function, whereby aberration improvement performance may be improved.

In addition, the optical system may implement a wide angle by widening a field of view (FOV).

In addition, in the optical system, all of the lenses are formed of plastic, whereby a cost required for manufacturing a lens module may be decreased and manufacturing efficiency of the lens module may be increased.

An optical system according to a first exemplary embodiment of the present disclosure will be described with reference to FIGS. 1 through 4.

The optical system according to a first exemplary embodiment of the present disclosure may include a first lens 110, a second lens 120, a third lens 130, a fourth lens 140, and a fifth lens 150, and may further include an infrared cut-off filter 160 and an image sensor 170.

Here, as shown in Table 1, a field of view (FOV) of the optical system may be 90 degrees, and a distance (TTL) of an object-side surface of the first lens 110 to a first surface (imaging surface) of the image sensor 170 may be 3.9 mm.

In addition, a focal length (F1) of the first lens 110 may be -4.42 mm, a focal length (F2) of the second lens 120 may be 1.52 mm, a focal length (F3) of the third lens 130 may be -134.04 mm, a focal length (F4) of the fourth lens 140 may be 1.85 mm, a focal length (F5) of the fifth lens 150 may be -5.07 mm, and an overall focal length (F) of the optical system may be 1.5 mm.

TABLE 1

FOV	90
TTL	3.9
F	1.5
F1	-4.42
F2	1.52
F3	-134.04
F4	1.85
F5	-5.07

Here, lens characteristics (radii of curvature, thicknesses of lenses or distances between the lenses, refractive indices, and Abbe's numbers) of each lens are shown in FIG. 3.

In a first exemplary embodiment of the present disclosure, the first lens 110 may have negative refractive power, and have a meniscus shape in which it is convex toward the object. The second lens 120 may have positive refractive power and have both surfaces that are convex. The third lens 130 may have negative refractive power and have a meniscus shape in which it is convex toward the image. The fourth lens 140 may have positive refractive power and have a meniscus shape in which it is convex toward the image. The fifth lens 150 may have negative refractive power and have a meniscus shape in which it is convex toward the object. In addition, the fifth lens 150 may have at least one inflection point formed on each of first and second surfaces thereof.

Meanwhile, the respective surfaces of the first to fifth lenses 110 to 150 may have aspherical surface coefficients as shown in FIG. 4. For example, all of the first surface of the first lens 110 to the second surface of the fifth lens 150 may be aspherical.

In addition, the optical system configured as described above may have aberration characteristics shown in FIG. 2.

6

An optical system according to a second exemplary embodiment of the present disclosure will be described with reference to FIGS. 5 through 8.

The optical system according to a second exemplary embodiment of the present disclosure may include a first lens 210, a second lens 220, a third lens 230, a fourth lens 240, and a fifth lens 250, and may further include an infrared cut-off filter 260 and an image sensor 270.

Here, as shown in Table 2, a field of view (FOV) of the optical system may be 90 degrees, and a distance (TTL) of an object-side surface of the first lens 210 to a first surface (imaging surface) of the image sensor 270 may be 3.9 mm.

In addition, a focal length (F1) of the first lens 210 may be -4.40 mm, a focal length (F2) of the second lens 220 may be 1.53 mm, a focal length (F3) of the third lens 230 may be -88.04 mm, a focal length (F4) of the fourth lens 240 may be 1.86 mm, a focal length (F5) of the fifth lens 250 may be -5.00 mm, and an overall focal length (F) of the optical system may be 1.5 mm.

TABLE 2

FOV	90
TTL	3.9
F	1.5
F1	-4.40
F2	1.53
F3	-88.04
F4	1.86
F5	-5.00

Here, lens characteristics (radii of curvature, thicknesses of lenses or distances between the lenses, refractive indices, Abbe's numbers) of each lens are shown in FIG. 7.

In a second exemplary embodiment of the present disclosure, the first lens 210 may have negative refractive power, and have a meniscus shape in which it is convex toward the object. The second lens 220 may have positive refractive power and have both surfaces that are convex. The third lens 230 may have negative refractive power and have a meniscus shape in which it is convex toward the image. The fourth lens 240 may have positive refractive power and have a meniscus shape in which it is convex toward the image. The fifth lens 250 may have negative refractive power and have a meniscus shape in which it is convex toward the object. In addition, the fifth lens 250 may have at least one inflection point formed on each of first and second surfaces thereof.

Meanwhile, the respective surfaces of the first to fifth lenses 210 to 250 may have aspherical surface coefficients as shown in FIG. 8. For example, all of the first surface of the first lens 210 to the second surface of the fifth lens 250 may be aspherical.

In addition, the optical system configured as described above may have aberration characteristics shown in FIG. 6.

An optical system according to a third exemplary embodiment of the present disclosure will be described with reference to FIGS. 9 through 12.

The optical system according to a third exemplary embodiment of the present disclosure may include a first lens 310, a second lens 320, a third lens 330, a fourth lens 340, and a fifth lens 350, and may further include an infrared cut-off filter 360 and an image sensor 370.

Here, as shown in Table 3, a field of view (FOV) of the optical system may be 80 degrees, and a distance (TTL) of an object-side surface of the first lens 310 to a first surface (imaging surface) of the image sensor 370 may be 3.9 mm.

In addition, a focal length (F1) of the first lens 310 may be -4.39 mm, a focal length (F2) of the second lens 320 may

be 1.53 mm, a focal length (F3) of the third lens 330 may be -82.65 mm, a focal length (F4) of the fourth lens 340 may be 1.86 mm, a focal length (F5) of the fifth lens 350 may be -5.01 mm, and an overall focal length (F) of the optical system may be 1.5 mm.

TABLE 3

FOV	80
TTL	3.9
F	1.5
F1	-4.39
F2	1.53
F3	-82.65
F4	1.86
F5	-5.01

Here, lens characteristics (radii of curvature, thicknesses of lenses or distances between the lenses, refractive indices, Abbe's numbers) of each lens are shown in FIG. 11.

In a third exemplary embodiment of the present disclosure, the first lens 310 may have negative refractive power, and have a meniscus shape in which it is convex toward the object. The second lens 320 may have positive refractive power and have both surfaces that are convex. The third lens 330 may have negative refractive power and have a meniscus shape in which it is convex toward the image. The fourth lens 340 may have positive refractive power and have a meniscus shape in which it is convex toward the image. The fifth lens 350 may have negative refractive power and have a meniscus shape in which it is convex toward the object. In addition, the fifth lens 350 may have at least one inflection point formed on each of first and second surfaces thereof.

Meanwhile, the respective surfaces of the first to fifth lenses 310 to 350 may have aspherical surface coefficients as shown in FIG. 12. For example, all of the first surface of the first lens 310 to the second surface of the fifth lens 350 may be aspherical.

In addition, the optical system configured as described above may have aberration characteristics shown in FIG. 10.

TABLE 4

	First Exemplary Embodiment	Second Exemplary Embodiment	Third Exemplary Embodiment
FOV/TTL	23.08	23.08	20.51
TTL/F	2.60	2.60	2.60
F1/F	-2.95	-2.93	-2.93
F2/F	1.02	1.02	1.02
F3/F	-89.36	-58.69	-55.10
F4/F	1.24	1.24	1.24
F5/F	-3.38	-3.34	-3.34
FOV	90	90	80

Meanwhile, it may be appreciated from Table 4 that the optical systems according to first to third exemplary embodiments of the present disclosure satisfy Conditional Equations 1 to 8 described above. Therefore, a wide angle may be implemented, and optical performance of the lens may be improved.

As set forth above, with the optical systems according to exemplary embodiments of the present disclosure, the field of view may be widened to implement the wide angle, and the aberration may be improved to improve the optical performance.

While exemplary embodiments have been shown and described above, it will be apparent to those skilled in the art that modifications and variations could be made without departing from the scope of the present invention as defined by the appended claims.

What is claimed is:

1. An optical system comprising:
 - a first lens having negative refractive power, of which an object-side surface is convex;
 - a second lens having positive refractive power;
 - a third lens having negative refractive power, of which an object-side surface is concave;
 - a fourth lens having positive refractive power, of which an image-side surface is convex; and
 - a fifth lens having negative refractive power and having a meniscus shape in which an object-side surface of the fifth lens is convex,
 wherein the first to fifth lenses are sequentially disposed from an object side,

and wherein Conditional Expression 6 is satisfied:

$$-90 < F3/F < -55 \quad \text{[Conditional Expression 6]}$$

where F3 is a focal length of the third lens, and F is an overall focal length of the optical system.

2. The optical system of claim 1, wherein the first lens has a meniscus shape.
3. The optical system of claim 1, wherein both surfaces of the second lens are convex.
4. The optical system of claim 1, wherein the third lens has a meniscus shape in which an image-side surface of the third lens is convex.
5. The optical system of claim 1, wherein the fourth lens has a meniscus shape.
6. The optical system of claim 1, wherein the fifth lens has at least one inflection point formed on an object-side surface of the fifth lens.
7. The optical system of claim 1, wherein the fifth lens has at least one inflection point formed on an image-side surface of the fifth lens.
8. The optical system of claim 1, wherein Conditional Expression 1 is satisfied:

$$FOV \geq 80 \quad \text{[Conditional Expression 1]}$$

where FOV is a field of view of the optical system.

9. The optical system of claim 1, further comprising an image sensor converting an image of a subject incident through the first to fifth lenses into an electrical signal, wherein Conditional Expression 2 is satisfied:

$$FOV/TTL > 20 \quad \text{[Conditional Expression 2]}$$

where FOV is a field of view of the optical system, and TTL is a distance from the object-side surface of the first lens to an imaging surface of the image sensor.

10. The optical system of claim 1, further comprising an image sensor converting an image of a subject incident through the first to fifth lenses into an electrical signal, wherein Conditional Expression 3 is satisfied:

$$TTL/F < 2.7 \quad \text{[Conditional Expression 3]}$$

where TTL is a distance from the object-side surface of the first lens to an imaging surface of the image sensor, and F is an overall focal length of the optical system.

11. The optical system of claim 1, wherein Conditional Expression 4 is satisfied:

$$-3 < F1/F < -1 \quad \text{[Conditional Expression 4]}$$

where F1 is a focal length of the first lens, and F is an overall focal length of the optical system.

12. The optical system of claim 1, wherein Conditional Expression 5 is satisfied:

$$0.8 < F2/F < 1.1 \quad \text{[Conditional Expression 5]}$$

where F2 is a focal length of the second lens, and F is an overall focal length of the optical system.

13. The optical system of claim 1, wherein Conditional Expression 7 is satisfied:

$$1.0 < F4/F < 1.3 \quad \text{[Conditional Expression 7]}$$

where F4 is a focal length of the fourth lens, and F is an overall focal length of the optical system.

14. The optical system of claim 1, wherein Conditional Expression 8 is satisfied:

$$-3.4 < F5/F < -3.0 \quad \text{[Conditional Expression 8]}$$

where F5 is a focal length of the fifth lens, and F is an overall focal length of the optical system.

15. The optical system of claim 1, wherein the first to fifth lenses are plastic lenses.

16. The optical system of claim 1, wherein all of the respective surfaces of the first to fifth lenses are aspherical.

17. An optical system comprising:

a first lens having refractive power and having a meniscus shape in which an object-side surface of the first lens is convex;

a second lens having positive refractive power;

a third lens having refractive power, of which an object-side surface is concave;

a fourth lens having refractive power and having a meniscus shape in which an image-side surface of the fourth lens is convex; and

a fifth lens having refractive power and having a meniscus shape in which an object-side surface of the fifth lens is convex,

wherein the first to fifth lenses are sequentially disposed from an object side, and

Conditional Expression 1 and Conditional Expression 6 are satisfied:

$$FOV \geq 80 \quad \text{[Conditional Expression 1]}$$

where FOV is a field of view of the optical system,

$$-90 < F3/F < -55 \quad \text{[Conditional Expression 6]}$$

where F3 is a focal length of the third lens, and F is an overall focal length of the optical system.

18. The optical system of claim 17, further comprising an image sensor converting an image of a subject incident through the first to fifth lenses into an electrical signal, wherein Conditional Expression 2 is satisfied:

$$FOV/TTL > 20 \quad \text{[Conditional Expression 2]}$$

where TTL is a distance from an object-side surface of the first lens to an imaging surface of the image sensor.

19. The optical system of claim 17, further comprising an image sensor converting an image of a subject incident through the first to fifth lenses into an electrical signal, wherein Conditional Expression 3 is satisfied:

$$TTL/F < 2.7 \quad \text{[Conditional Expression 3]}$$

where TTL is a distance from an object-side surface of the first lens to an imaging surface of the image sensor, and F is an overall focal length of the optical system.

20. The optical system of claim 17, wherein Conditional Expression 4 is satisfied:

$$-3 < F1/F < -1 \quad \text{[Conditional Expression 4]}$$

where F1 is a focal length of the first lens, and F is an overall focal length of the optical system.

21. The optical system of claim 17, wherein Conditional Expression 5 is satisfied:

$$0.8 < F2/F < 1.1 \quad \text{[Conditional Expression 5]}$$

where F2 is a focal length of the second lens, and F is an overall focal length of the optical system.

22. The optical system of claim 17, wherein Conditional Expression 7 is satisfied:

$$1.0 < F4/F < 1.3 \quad \text{[Conditional Expression 7]}$$

where F4 is a focal length of the fourth lens, and F is an overall focal length of the optical system.

23. The optical system of claim 17, wherein Conditional Expression 8 is satisfied:

$$-3.4 < F5/F < -3.0 \quad \text{[Conditional Expression 8]}$$

where F5 is a focal length of the fifth lens, and F is an overall focal length of the optical system.

24. The optical system of claim 17, wherein the first lens has negative refractive power.

25. The optical system of claim 17, wherein both surfaces of the second lens are convex.

26. The optical system of claim 17, wherein the third lens has negative refractive power, of which an image-side surface is convex.

27. The optical system of claim 17, wherein the fourth lens has positive refractive power.

28. The optical system of claim 17, wherein the fifth lens has negative refractive power and has at least one inflection point formed on each of an object-side surface and an image-side surface of the fifth lens.

* * * * *