



US009462640B2

(12) **United States Patent**
Fishman

(10) **Patent No.:** **US 9,462,640 B2**

(45) **Date of Patent:** **Oct. 4, 2016**

(54) **MELTING AND MIXING OF MATERIALS IN A CRUCIBLE BY ELECTRIC INDUCTION HEEL PROCESS**

(71) Applicant: **Inductotherm Corp.**, Rancocas, NJ (US)

(72) Inventor: **Oleg S. Fishman**, Maple Glen, PA (US)

(73) Assignee: **INDUCTOTHERM CORP.**, Rancocas, NJ (US)

(*) Notice: Subject to any disclaimer, the term of this patent is extended or adjusted under 35 U.S.C. 154(b) by 609 days.

(21) Appl. No.: **14/021,520**

(22) Filed: **Sep. 9, 2013**

(65) **Prior Publication Data**

US 2014/0010256 A1 Jan. 9, 2014

Related U.S. Application Data

(62) Division of application No. 12/268,846, filed on Nov. 11, 2008, now Pat. No. 8,532,158.

(60) Provisional application No. 60/988,783, filed on Nov. 17, 2007.

(51) **Int. Cl.**
H05B 6/34 (2006.01)
H05B 6/06 (2006.01)

(Continued)

(52) **U.S. Cl.**
CPC **H05B 6/34** (2013.01); **F27B 14/061** (2013.01); **F27B 14/14** (2013.01); **F27D 99/0006** (2013.01); **H05B 6/067** (2013.01); **H05B 6/24** (2013.01); **H05B 6/32** (2013.01); **H05B 6/367** (2013.01); **H05B 6/44** (2013.01); **H05B 2213/02** (2013.01)

(58) **Field of Classification Search**
CPC F27B 14/061; F27B 14/14; F27B 14/10;

F27B 14/20; H05B 6/04; H05B 6/06; H05B 6/30; H05B 6/32; H05B 6/40; H05B 6/44; H05B 6/067; H05B 6/34; H05B 6/367; H05B 6/24; H05B 6/22; H05B 6/101; H05B 6/105; H05B 2213/02; F27D 99/0006
USPC 373/146, 148, 156, 138, 139, 144, 150, 373/151, 152, 7, 59, 147, 142; 219/671, 219/662, 634, 661, 663; 266/233, 234
See application file for complete search history.

(56) **References Cited**

U.S. PATENT DOCUMENTS

3,396,229 A * 8/1968 Sundberg H05B 6/067
373/146
3,478,156 A * 11/1969 Segsworth G06K 9/60
373/146
4,238,637 A * 12/1980 Bingen H05B 6/067
373/146

(Continued)

Primary Examiner — Hung D Nguyen
(74) *Attorney, Agent, or Firm* — Philip O. Post

(57) **ABSTRACT**

Apparatus and method are provided for electric induction heating and melting of a transition material that is non-electrically conductive in the solid state and electrically conductive in the non-solid state in an electric induction heating and melting process wherein solid or semi-solid charge is periodically added to a heel of molten transition material initially placed in a refractory crucible. Induction power is sequentially supplied to a plurality of coils surrounding the exterior height of the crucible at high power level and high frequency with in-phase voltage until a crucible batch of transition material is in the crucible when the induction power is reduced in power level and frequency with voltage phase shifting to the induction coils along the height of the crucible to induce a unidirectional electromagnetic stir of the crucible batch of material.

10 Claims, 4 Drawing Sheets

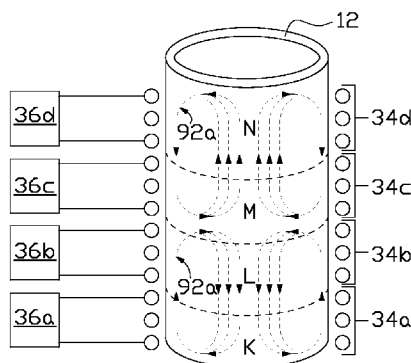

(51) **Int. Cl.**
H05B 6/22 (2006.01)
F27B 14/06 (2006.01)
F27B 14/14 (2006.01)
F27D 99/00 (2010.01)
H05B 6/32 (2006.01)
H05B 6/36 (2006.01)
H05B 6/24 (2006.01)
H05B 6/44 (2006.01)

(56) **References Cited**
U.S. PATENT DOCUMENTS
6,819,704 B2 * 11/2004 Fishman C22B 9/003
373/138
7,197,061 B1 * 3/2007 Fishman C30B 11/003
373/138
2004/0028111 A1 * 2/2004 Fishman H05B 6/04
373/146
* cited by examiner

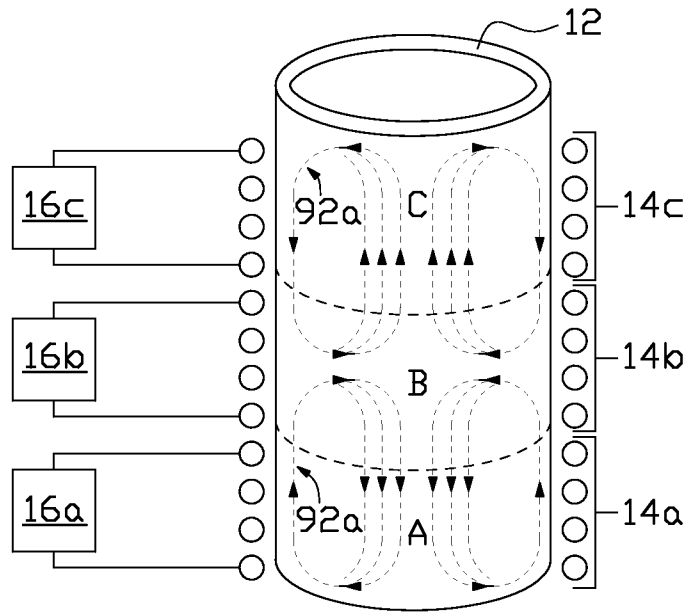

FIG. 1

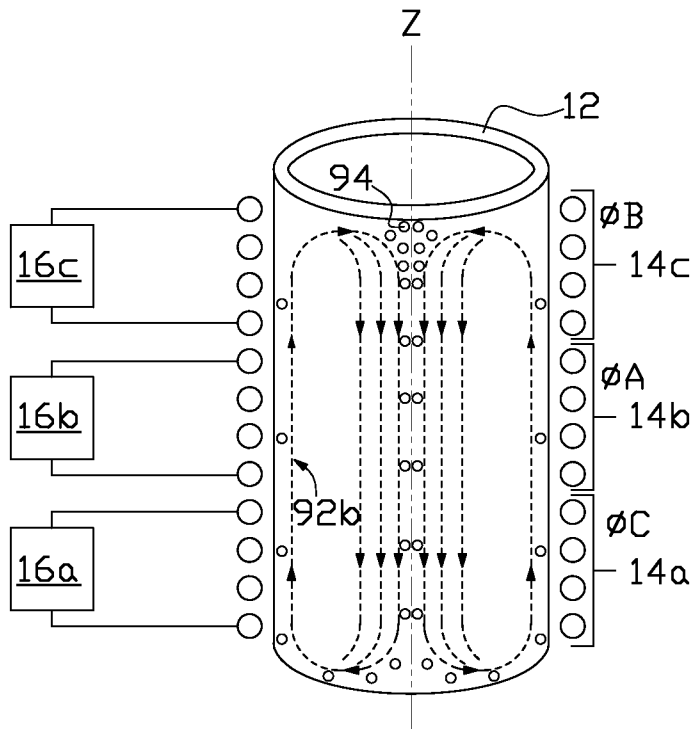

FIG. 2(a)

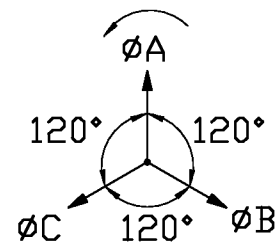

FIG. 2(b)

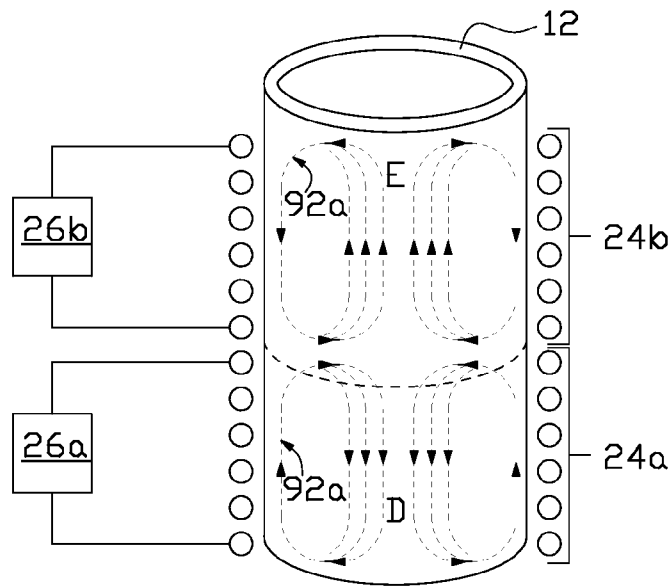

FIG. 3

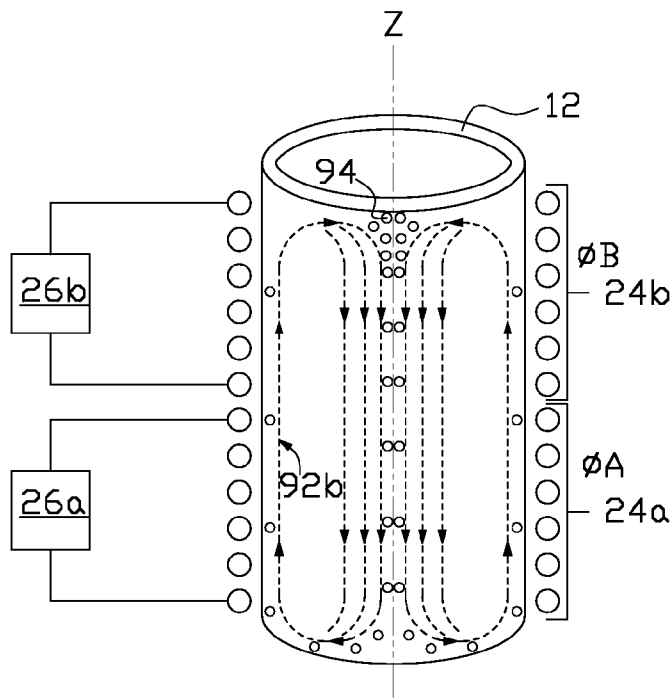

FIG. 4(a)

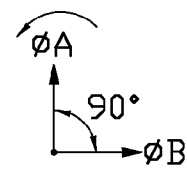

FIG. 4(b)

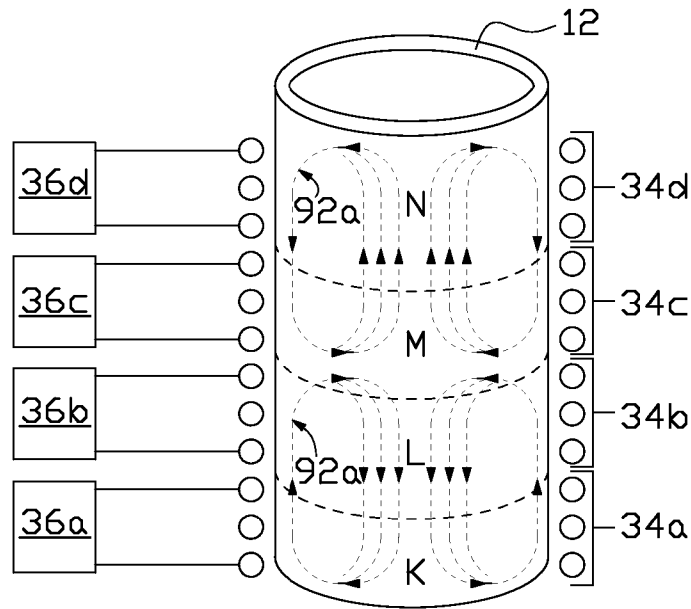

FIG. 5

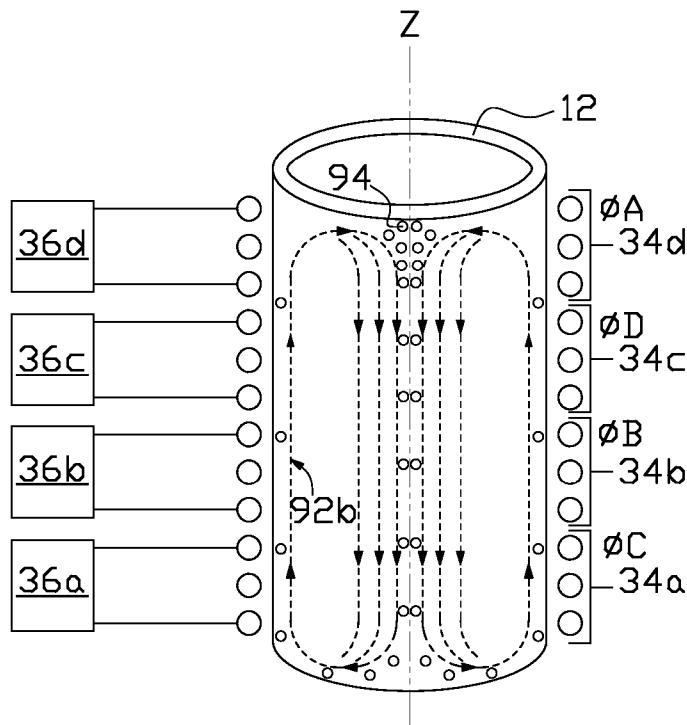

FIG. 6(a)

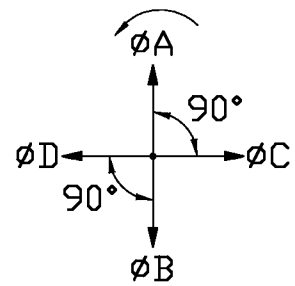

FIG. 6(b)

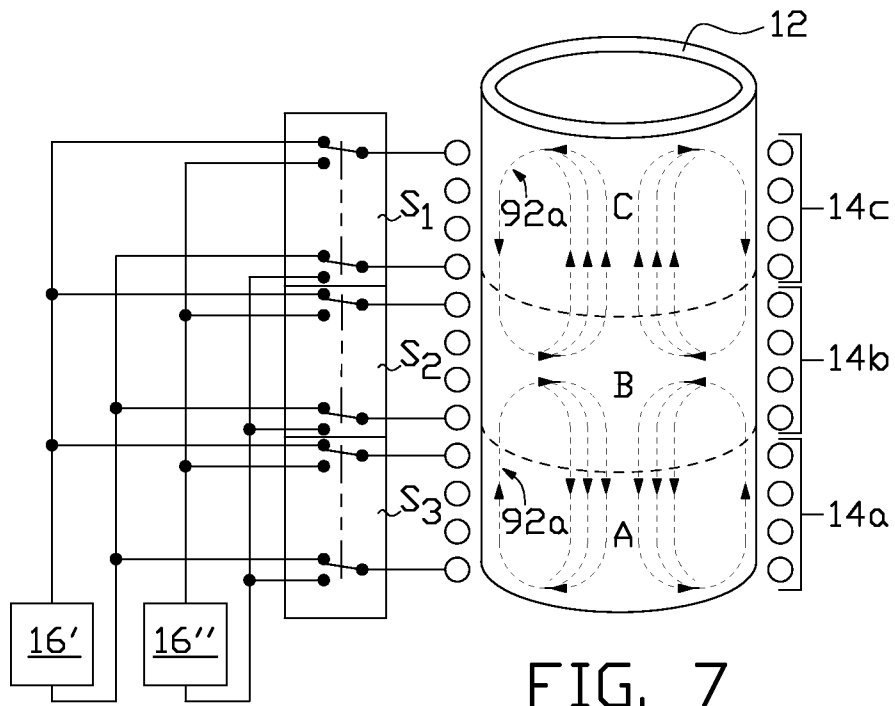

FIG. 7

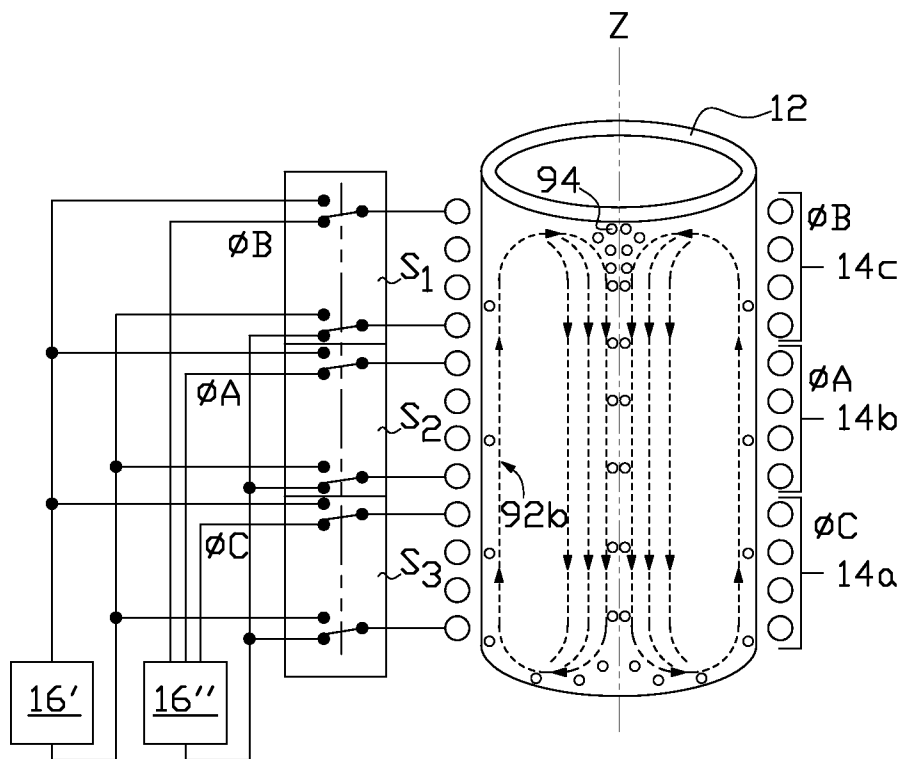

FIG. 8

1

MELTING AND MIXING OF MATERIALS IN A CRUCIBLE BY ELECTRIC INDUCTION HEEL PROCESS

CROSS REFERENCE TO RELATED APPLICATIONS

This is a divisional application of application Ser. No. 12/268,846, filed Nov. 11, 2008, which application claims the benefit of U.S. Provisional Application No. 60/988,783, filed Nov. 17, 2007, both of which applications are hereby incorporated herein by reference in their entireties.

FIELD OF THE INVENTION

The present invention relates to electric induction melting and mixing of materials that are in a non-electrically conductive state when gradually added to an induction refractory crucible initially holding a heel, or bottom layer, of electrically conductive molten material.

BACKGROUND OF THE INVENTION

Batch and heel are two types of electric induction processes for heating and melting of electrically conductive materials. In the batch process, a crucible is filled with a batch of electrically conductive solid charge that is melted by electric induction and then emptied from the crucible. In the heel process, a molten heel (bottom pool) of electrically conductive material is always maintained in the crucible while solid electrically conductive charge is added to the heel in the crucible and then melted by electric induction. Inductively heating and melting by the heel process when the material is non-electrically conductive in the solid state and electrically conductive in the molten state (referred to as a transition material), such as silicon, is problematic in that addition of solid non-electrically conductive charge to the molten heel must be adequately melted and mixed so that the added solid charge does not accumulate to form aggregate non-electrically conductive solid masses in, or over, the surface of the molten material.

It is one object of the present invention to provide apparatus for, and method of, heating and melting of a material that is non-electrically conductive in the solid state and electrically conductive in the molten state in a heel electric induction heating and melting process.

BRIEF SUMMARY OF THE INVENTION

In one aspect the present invention is apparatus for, and method of, electric induction heating and melting of a transition material that is non-electrically conductive in the solid state and is electrically conductive in the non-solid state in a heel electric induction heating and melting process. Multiple coils are provided around the height of the crucible, which contains a heel of molten transition material at the start of the melting process. Initially, relatively high magnitude, in-phase melting power at a relatively high frequency is sequentially supplied to each coil from one or more power supplies until the crucible is filled with transition material. When the crucible is substantially filled with transition material, the output frequency of the one or more power supplies is lowered to a stirring frequency along with the magnitude of the output power, while an out-of-phase relationship is established between the output voltages of the power supplies to achieve a preferred electromagnetic stir pattern.

2

The above and other aspects of the invention are set forth in this specification and the appended claims.

BRIEF DESCRIPTION OF THE DRAWINGS

The appended drawings, as briefly summarized below, are provided for exemplary understanding of the invention, and do not limit the invention as further set forth in this specification:

FIGS. 1 and 2(a) are simplified diagrams of one example of the present invention utilizing three separate induction coils (shown in cross section) wound around the exterior of a crucible, and FIG. 2(b) is a vector diagram illustrating phase relationships for voltage outputs of power supplies used in the example to achieve a preferred electromagnetic stir pattern.

FIGS. 3 and 4(a) are simplified diagrams of another example of the present invention utilizing two separate induction coils (shown in cross section) wound around the exterior of a crucible, and FIG. 4(b) is a vector diagram illustrating phase relationships for voltage outputs of power supplies used in the example to achieve a preferred electromagnetic stir pattern.

FIGS. 5 and 6(a) are simplified diagrams of another example of the present invention utilizing four separate induction coils (shown in cross section) wound around the exterior of a crucible, and FIG. 6(b) is a vector diagram illustrating phase relationships for voltage outputs of power supplies used in the example to achieve a preferred electromagnetic stir pattern.

FIG. 7 and FIG. 8 are simplified diagrams of another example of the present invention utilizing three separate induction coils (shown in cross section) wound around the exterior of a crucible.

DETAILED DESCRIPTION OF THE INVENTION

Referring to FIG. 1 and FIG. 2(a), in one non-limiting example of the present invention, refractory crucible 12 is exteriorly surrounded by lower volume induction coil 14a, central volume induction coil 14b and upper volume induction coil 14c. Interior lower volume A of the crucible is generally the interior region of the crucible surrounded by lower volume induction coil 14a; interior central volume B of the crucible is generally the interior region of the crucible surrounded by central volume induction coil 14b; and interior upper volume C of the crucible is generally the interior region of the crucible surrounded by upper volume induction coil 14c. The approximate boundaries of each interior volume are indicated by dashed lines in the figures. Lower volume induction coil 14a is disposed around at least the minimum level of operating heel of material to be generally maintained in the furnace. Separate power supplies 16a, 16b and 16c supply ac power to each of the lower, central and upper induction coils, respectively. Each power supply may comprise, for example, a converter/inverter that rectifies ac utility power to dc power, which dc power is converted to ac power with suitable characteristics for connection to one of the induction coils. In operation, starting with only the heel of molten transition material in the crucible, power supply 16a operates at a relatively high frequency, f_1 , for example 120 Hertz in this non-limiting example, and at a relatively high power output, for example full output voltage (power) rating (normalized as 1.0), as charge is added to the crucible. Charge of solid and/or semi-solid transition material is gradually added to the heel of material in the crucible. For example, the starting heel of molten transition material may

represent 20 percent of the full (100 percent) capacity of the crucible. If the transition material is silicon, added charge may be in the form of silicon granules, or other forms of metallurgical grade silicon, and the heel of molten silicon is kept at or above its melting temperature (nominally 1,450° C.) by flux coupling with the magnetic field created by current flow through induction coil **14a**. When sufficient charge has been added to at least partially occupy central volume B of the crucible, the output of power supply **16b** is applied to central volume induction coil **14b** at substantially the same frequency, f_1 , as the output of power supply **16a**, and at substantially the same relatively high power output as that for power supply **16a**. Voltage outputs for power supplies **16a** and **16b** are synchronized in-phase. The magnetic field created by current flow through induction coil **14b** couples with silicon in the central volume of the crucible to inductively heat the silicon primarily in the central volume. When sufficient charge has been added to at least partially occupy upper volume C of the crucible, the output of power supply **16c** is applied to upper volume induction coil **14c** at substantially the same frequency, f_1 , as the outputs of power supplies **16a** and **16b**, and at substantially the same relatively high power output as that for power supplies **16a** and **16b**, with the voltage outputs of the three power supplies operating in-phase. The magnetic field created by current flow through induction coil **14c** couples with silicon in the upper volume of the crucible to inductively heat the silicon primarily in the upper volume. The above operating conditions for this non-limiting example of the invention are summarized in the following table:

	output frequency	output power magnitude (normalized)	phase relationships of output voltages
power supply 16a	f_1	1.0	in-phase
power supply 16b	f_1	1.0	in-phase
power supply 16c	f_1	1.0	in-phase

With the operating conditions identified in the above table, the induced electromagnetic stir pattern can be represented by exemplary flow lines **92a** (shown in dashed lines) in FIG. 1, which is a double vortex ring, or toroidal vortex, flow pattern with separate vortex rings in the lower and upper halves of the crucible.

After the crucible is substantially filled with solid and/or semi-solid charge of transition material to a level that includes at least a part of upper crucible volume C, the output frequency of all three power supplies can be lowered to the same frequency, which is lower than f_1 , for example, $f_2=0.5f_1$ (60 Hertz in this non-limiting example) with all three power supplies operating at a reduced voltage (power) output, for example 0.5 normalized power output, with 120 degrees out-of-phase voltage orientations as illustrated by the vector diagram in FIG. 2(b). The above operating conditions for this non-limiting example of the invention are summarized in the following table:

	output frequency	output power magnitude (normalized)	phase relationships of output voltages
power supply 16a	$0.5f_1$	0.5	120 degrees phase shift
power supply 16b	$0.5f_1$	0.5	120 degrees phase shift
power supply 16c	$0.5f_1$	0.5	120 degrees phase shift

With the operating conditions identified in the above table, the induced electromagnetic stir pattern can be represented by exemplary flow lines **92b** (shown in dashed lines) in FIG. 2(a) to create a single vortex ring flow pattern in the crucible with a downward flow pattern about the poloidal (circular) axis Z of the ring, or counterclockwise poloidal rotation. With this flow pattern, remaining solid or semi-solid transition material from the charge in the crucible will be drawn downwards around the poloidal axis of the ring in the central vertical region of the interior of the crucible and upwards along the inner walls of the crucible to rapidly melt any of the remaining solid or semi-solid transition material **94** from the charge added to the heel of material in the crucible. The poloidal rotation may be reversed to clockwise by reversing the phase rotation of the power supplies; that is, the A-C-B phase rotation for counterclockwise poloidal rotation can be changed to A-B-C phase rotation for clockwise poloidal rotation. In some examples of the invention, alternating or jogging back and forth between the counterclockwise and clockwise directions may be preferable for at least some of the stirring time period to assist in melting and stirring of the added charge.

After melting all added transition charge material, molten transition material may be extracted from the crucible by any suitable extraction process, such as, but not limited to, bottom pour through a reclosable tap in the crucible, tilt pour by suitable crucible tilting apparatus, or pressure pour by enclosing the crucible and forcing molten material from the crucible out of a passage by applying positive pressure to the volume of molten material in the crucible, while leaving a required heel of molten transition material in the crucible to be used at the start of the next charge melting process.

Alternatively the molten transition material may be directionally solidified in the crucible by removing power sequentially from the lower, central and upper volume induction coils so that the mass of molten silicon in the crucible solidifies from bottom to top.

By way of example and not limitation, in some examples of the invention, power supplies **16a**, **16b** and **16c** may operate alternatively only: either with fixed output frequency f_1 , high output voltage (power) magnitude and phase synchronized for melting of transition material; or with fixed output frequency f_2 , low output voltage (power) magnitude and 120 degrees shift between phases for stirring of transition material. In other examples of the invention, the three power supplies may be replaced with a single three phase power supply with 120 degrees shift between phases and connection of each phase to one of the three coils for stirring. For the above example, since the stir frequency f_2 , is in the range of nominal utility frequency (50 to 60 Hertz), the stir power supply may be derived from a utility source with phase shifting, if required. A suitable switching arrangement may be provided for switching the outputs of the single three phase supply with a source of in-phase power to the three induction coils to transition from primarily stirring to melting. For example in FIG. 7 during the process step when charge is being added to the crucible, all three induction coils can be connected to the common single phase output of single high power, high frequency output power supply **16'** via switches S_1 , S_2 and S_3 . After a crucible batch of transition material has been added to the crucible, the positions of switches S_1 , S_2 and S_3 can be changed so that the three induction coils are connected to a three phase utility power source **16''** as shown in FIG. 8. In other examples of the invention, the power supplies may be arranged to alternate between the melting and stirring states.

In another example of the present invention, referring to FIG. 3 and FIG. 4(a), refractory crucible **12** is exteriorly surrounded by lower volume induction coil **24a** and upper

5

volume induction coil **24b**. Interior lower volume D of the crucible is generally the interior region of the crucible surrounded by lower volume induction coil **24a**, and interior upper volume E of the crucible is generally the interior region of the crucible surrounded by upper volume induction coil **24b**. The approximate boundaries of each interior volume are indicated by dashed lines in the figures. Lower volume induction coil **24a** is disposed around at least the minimum level of operating heel of material to be generally maintained in the furnace. Separate power supplies **26a** and **26b** supply ac power to each of the lower and upper induction coils, respectively. Each power supply may comprise, for example, a converter/inverter that rectifies ac utility power to dc power, which dc power is converted to ac power with suitable characteristics for connection to one of the induction coils. In operation, starting with only the heel of molten transition material in the crucible, power supply **26a** operates at a relatively high frequency, f_1 , for example 120 Hertz in this non-limiting example, and at a relatively high power output, for example full output voltage (power) rating (normalized as 1.0), as charge is added to the crucible. Charge of solid and/or semi-solid transition material is gradually added to the heel of material in the crucible. For example, the starting heel of molten transition material may represent 20 percent of the full (100 percent) capacity of the crucible. If the transition material is silicon, added charge may be in the form of silicon granules, or other forms of metallurgical grade silicon, and the heel of molten silicon is kept at or above its melting temperature (nominally 1,450° C.) by flux coupling with the magnetic field created by current flow through induction coil **24a**. When sufficient charge has been added to at least partially occupy upper volume E of the crucible, the output of power supply **26b** is applied to upper volume induction coil **24b** at substantially the same frequency, f_1 , as the output of power supply **26a**, and at substantially the same relatively high power output as that for power supply **26a**. Voltage outputs for power supplies **26a** and **26b** are synchronized in-phase. The magnetic field created by current flow through induction coil **24b** couples with silicon in the upper volume of the crucible to heat the silicon primarily in the upper zone. The above operating conditions for this non-limiting example of the invention are summarized in the following table:

	output frequency	output power magnitude (normalized)	phase relationships of output voltages
power supply 26a	f_1	1.0	in-phase
power supply 26b	f_1	1.0	in-phase

With the operating conditions identified in the above table, the induced electromagnetic stir pattern can be represented by exemplary flow lines **92a** (shown in dashed lines) in FIG. 3, which is a double vortex ring flow pattern with separate vortex rings in the lower and upper halves of the crucible.

After the crucible is filled with solid and/or semi-solid charge of transition material to a level that includes at least a part of upper crucible volume E, the output frequency of both power supplies can be lowered to the same frequency, which is lower than f_1 , for example, $f_2=0.5f_1$ (60 Hertz in this non-limiting example) with both power supplies operating at a reduced voltage (power) output, for example 0.5

6

FIG. 4(b). The above operating conditions for this non-limiting example of the invention are summarized in the following table:

	output frequency	output power magnitude (normalized)	phase relationships of output voltages
power supply 26a	$0.5f_1$	0.5	90 degrees phase shift
power supply 26b	$0.5f_1$	0.5	90 degrees phase shift

With the operating conditions identified in the above table, the induced electromagnetic stir pattern can be represented by exemplary flow lines **92b** (shown in dashed lines) in FIG. 4(a) to create a single vortex ring flow pattern in the crucible with a downward flow pattern about the poloidal (circular) axis Z of the ring, or counterclockwise poloidal rotation. With this flow pattern, remaining solid or semi-solid transition material from the charge in the crucible will be drawn downwards around the poloidal axis of the ring in the central vertical region of the interior of the crucible and upwards along the inner walls of the crucible to rapidly melt any of the remaining solid or semi-solid transition material **94** from the charge added to the heel in the crucible. The poloidal rotation may be reversed to clockwise by reversing the phase rotation of the power supplies; that is, the B-A phase rotation for counterclockwise poloidal rotation can be changed to A-B phase rotation for clockwise poloidal rotation. In some examples of the invention, alternating or jogging back and forth between the counterclockwise and clockwise directions may be preferable for at least some of the stirring time period to assist in melting and stirring of the added charge.

After melting all added transition charge material, molten transition material may be extracted from the crucible by any suitable extraction process, such as, but not limited to, bottom pour through a reclosable tap in the crucible, tilt pour by suitable crucible tilting apparatus, or pressure pour by enclosing the crucible and forcing molten material from the crucible out of a passage by applying positive pressure to the volume of molten material in the crucible, while leaving a required heel of molten transition material in the crucible to be used at the start of the next charge melting process.

Alternatively the molten transition material may be directionally solidified in the crucible by removing power sequentially from the lower and upper volume induction coils so that the mass of molten silicon in the crucible solidifies from bottom to top.

By way of example and not limitation, in some examples of the invention, power supplies **26a** and **26b** may operate alternatively only: either with fixed output frequency f_1 , high output voltage (power) magnitude and phase synchronized for melting of transition material; or with fixed output frequency f_2 , low output voltage (power) magnitude and 90 degrees shift between phases for stirring of transition material. In other examples of the invention, the two power supplies may be replaced with a single two phase power supply with 90 degrees shift between phases and connection of each phase to one of the two coils for stirring. For the above example, since the stir frequency f_2 , is utility frequency, 60 Hertz, the stir power supply may be derived from a utility source with phase shifting, if required. A suitable switching arrangement may be provided for switching the outputs of the single two phase supply with a source of in-phase power to the two induction coils to transition from primarily stirring to melting. In other examples of the

invention, the power supplies may be arranged to alternate between the melting and stirring states.

In another example of the present invention, referring to FIG. 5 and FIG. 6(a), refractory crucible 12 is exteriorly surrounded by first quadrant volume induction coil 34a; second quadrant volume induction coil 34b, third quadrant volume induction coil 34c; and fourth quadrant volume induction coil 34d. Interior first quadrant volume K of the crucible is generally the interior region of the crucible surrounded by first quadrant volume induction coil 34a; interior second quadrant volume L of the crucible is generally the interior region of the crucible surrounded by second quadrant volume induction coil 34b; interior third quadrant volume M of the crucible is generally the interior region of the crucible surrounded by third quadrant volume induction coil 34c; and interior fourth quadrant volume N of the crucible is generally the interior region of the crucible surrounded by fourth quadrant volume induction coil 34d. The approximate boundaries of each interior volume are indicated by dashed lines in the figures. First quadrant volume induction coil 34a is disposed around at least the minimum level of operating heel to be generally maintained in the furnace. Power supplies 36a, 36b, 36c and 36d supply ac power to the first, second, third and fourth quadrant induction coils, respectively. Each power supply may comprise, for example, a converter/inverter that rectifies ac utility power to dc power, which dc power is converted to ac power with suitable characteristics for connection to one of the induction coils. In operation, starting with only the heel of molten transition material in the crucible, power supply 36a operates at a relatively high frequency, f_1 , for example 120 Hertz in this non-limiting example, and at a relatively high power output, for example full output voltage (power) rating (normalized as 1.0), as charge is added to the crucible. Charge of solid and/or semi-solid transition material is gradually added to the heel of material in the crucible. For example, the starting heel of molten transition material may represent 20 percent of the full (100 percent) capacity of the crucible. If the transition material is silicon, added charge may be in the form of silicon granules, or other forms of metallurgical grade silicon, and the heel of molten silicon is kept at or above its melting temperature (nominally 1,450° C.) by flux coupling with the magnetic field created by current flow through induction coil 34a. When sufficient charge has been added to at least partially occupy second quadrant volume L of the crucible, the output of power supply 36b is applied to second quadrant volume induction coil 34b at substantially the same frequency, f_1 , as the output of power supply 36a, and at substantially the same relatively high power output as that for power supply 36a. Voltage outputs for power supplies 36a and 36b are synchronized in-phase. The magnetic field created by current flow through induction coil 34b couples with silicon in the second quadrant volume of the crucible to inductively heat the silicon primarily in the second quadrant volume. When sufficient charge has been added to at least partially occupy third quadrant volume M of the crucible, the output of power supply 36c is applied to third quadrant volume induction coil 34c at substantially the same frequency, f_1 , as the outputs of power supplies 36a and 36b, and at substantially the same relatively high power output as that for power supplies 36a and 36b, with the voltage outputs of the three power supplies operating in-phase. The magnetic field created by current flow through induction coil 34c couples with silicon in the third quadrant volume of the crucible to inductively heat the silicon primarily in the third quadrant volume. When sufficient charge has been added to at least partially occupy

fourth quadrant volume N of the crucible, the output of power supply 36d is applied to fourth quadrant volume induction coil 34d at substantially the same frequency, f_1 , as the outputs of power supplies 36a, 36b and 36c, and at substantially the same relatively high power output as that for power supplies 36a, 36b and 36c, with the voltage outputs of the four power supplies operating in-phase. The magnetic field created by current flow through induction coil 34d couples in the fourth quadrant volume of the crucible to inductively heat the silicon primarily in the fourth quadrant volume. The above operating conditions for this non-limiting example of the invention are summarized in the following table:

	output frequency	output power magnitude (normalized)	phase relationships of output voltages
power supply 36a	f_1	1.0	in-phase
power supply 36b	f_1	1.0	in-phase
power supply 36c	f_1	1.0	in-phase
power supply 36d	f_1	1.0	in-phase

With the operating conditions identified in the above table, the induced electromagnetic stir pattern can be represented by exemplary flow lines 92a (shown in dashed lines) in FIG. 5, which is a double vortex ring, or toroidal vortex, flow pattern with separate vortex rings in the lower and upper halves of the crucible.

After the crucible is filled with solid and/or semi-solid charge of transition material to a level that includes at least a part of fourth quadrant crucible volume N, the output frequency of all four power supplies can be lowered to the same relatively low frequency, for example, $f_2=0.5f_1$ (60 Hertz in this non-limiting example) with all four power supplies operating at a reduced voltage (power) output, for example 0.5 normalized power output, with 90 degrees out-of-phase voltage orientations as illustrated by the vector diagram in FIG. 6(b). The above operating conditions for this non-limiting example of the invention are summarized in the following table:

	output frequency	output power magnitude (normalized)	phase relationships of output voltages
power supply 36a	$0.5f_1$	0.5	90 degrees phase shift
power supply 36b	$0.5f_1$	0.5	90 degrees phase shift
power supply 36c	$0.5f_1$	0.5	90 degrees phase shift
power supply 36d	$0.5f_1$	0.5	90 degrees phase shift

With the operating conditions identified in the above table, the induced electromagnetic stir pattern can be represented by exemplary flow lines 92b (shown in dashed lines) in FIG. 6(a) to create a single vortex ring flow pattern in the crucible with a downward flow pattern about the poloidal (circular) axis Z of the ring, or counterclockwise poloidal rotation. With this flow pattern, remaining solid or semi-solid transition material from the charge in the crucible will be drawn downwards around the poloidal axis of the ring in the central vertical region of the interior of the crucible and upwards along the inner walls of the crucible to rapidly melt any of the remaining solid or semi-solid transition material 94 from the charge added to the heel in the crucible. The poloidal rotation may be reversed to clockwise by reversing the phase rotation of the power supplies; that is, the A-D-B-C phase rotation for counterclockwise poloidal

rotation can be changed to A-C-B-D phase rotation for clockwise poloidal rotation. In some examples of the invention, alternating or jogging back and forth between the counterclockwise and clockwise directions may be preferable for at least some of the stirring time period to assist in melting and stirring of added charge.

After melting all added transition charge material, molten transition material may be extracted from the crucible by any suitable extraction process, such as, but not limited to, bottom pour through a reclosable tap in the crucible, tilt pour by suitable crucible tilting apparatus, or pressure pour by enclosing the crucible and forcing molten material from the crucible out of a passage by applying positive pressure to the volume of molten material in the crucible, while leaving a required heel of molten transition material in the crucible to be used at the start of the next charge melting process.

Alternatively the molten transition material may be directionally solidified in the crucible by removing power sequentially from the first quadrant, second quadrant, third quadrant and fourth quadrant volume induction coils so that the mass of molten silicon in the crucible solidifies from bottom to top.

By way of example and not limitation, in some examples of the invention, power supplies 36a, 36b, 36c and 36c may operate alternatively only: either with fixed output frequency f_1 , high output voltage (power) magnitude and phase synchronized for melting of transition material; or with fixed output frequency f_2 , low output voltage (power) magnitude and 90 degrees shift between phases for stirring of transition material. In other examples of the invention, the four power supplies may be replaced with a single four phase power supply with 90 degrees shift between phases and connection of each phase to one of the four coils for stirring. For the above example, since the stir frequency f_2 , is utility frequency, 60 Hertz, the stir power supply may be derived from a utility source with phase shifting, if required. A suitable switching arrangement may be provided for switching the outputs of the single four phase supply with a source of in-phase power to the four induction coils to transition from primarily stirring to melting. In other examples of the invention, the power supplies may be arranged to alternate between the melting and stirring states.

While the above examples of the invention comprise a specific number of induction coils and power supplies, other quantities of induction coils and power supplies may be used in the invention with suitable modification to particular arrangements. While each of the induction coils surrounds an equal portion of the refractory crucible, in other examples of the invention, the portions of the refractory crucible surrounded by each coil may be unequal so that each current flow in each coil may generate a magnetic field that couples with non-solid transition material in unequal interior volumes of the crucible.

The above examples of the invention have been provided for the purpose of explanation and are not limiting of the present invention. While the invention has been described with reference to various embodiments, the words used herein are words of description and illustration, rather than words of limitations. Although the invention has been described herein with reference to particular means, materials and embodiments, the invention is not intended to be limited to the particulars disclosed herein; rather, the invention extends to all functionally equivalent structures, methods and uses. Those skilled in the art, having the benefit of the teachings of this specification and the appended claims,

may effect numerous modifications thereto, and changes may be made without departing from the scope of the invention in its aspects.

The invention claimed is:

1. A method of melting a crucible batch of a transition material by gradually adding a solid or semi-solid charge of the transition material to a molten heel of the transition material in a crucible having a plurality of induction coils surrounding the exterior of the crucible, each one of the plurality of induction coils exclusively surrounding one of a plurality of partial interior volumes of the crucible, the lowest one of the plurality of partial interior volumes comprising a bottom interior volume and the highest one of the plurality of partial interior volumes comprising a top interior volume of the crucible, a first intermediate interior volume disposed above the bottom interior volume, and a second intermediate interior volume disposed above the first intermediate volume and below the top interior volume, each one of the plurality of induction coils connected to the output of a separate alternating current power source, the method comprising the steps of:

loading the molten heel of the transition material into at least a bottom portion of the bottom interior volume and adjusting the output of the separate alternating current power source connected to the one of the plurality of induction coils surrounding the bottom interior volume to a melting frequency and a melting power level to keep the molten heel of the transition material at least at the minimum melting temperature of the transition material;

sequentially adding the solid or semi-solid charge of the transition material into at least a portion of each of the first intermediate interior volume and the second intermediate interior volume above the bottom interior volume while adjusting the output of the separate alternating current power source connected to the one of the plurality of induction coils surrounding the first intermediate interior volume and the second intermediate interior volume to which the solid or semi-solid charge of the transition material is sequentially added to the melting frequency and the melting power level while synchronizing the phase of an output voltage of the separate alternating current power source connected to the one of the plurality of induction coils surrounding the first intermediate interior volume and the second intermediate interior volume to which the solid or semi-solid charge of the transition material is sequentially added with the phase of the output voltage of the separate alternating current power source connected to the one of the plurality of induction coils surrounding the bottom interior volume;

simultaneously adding the solid or semi-solid charge of the transition material into at least a top portion of the top interior volume of the crucible subsequent to sequentially adding the solid or semi-solid charge of the transition material into the first intermediate interior volume and the second intermediate interior volume to form the crucible batch of a molten transition material and adjusting the output of the separate alternating current power source connected to the one of the plurality of induction coils surrounding the top interior volume to the melting frequency and the melting power level while synchronizing the phase of the output voltage of the separate alternating current power source connected to the one of the plurality of induction coils surrounding the top interior volume with the phase of the output voltage of the separate alternating current

11

source connected to the one of the plurality of induction coils surrounding the bottom interior volume; and simultaneously reducing the output of each one of the separate alternating current power sources to a stirring frequency and a stirring power level while phase shifting the output voltages of each of the separate alternating current power sources to induce a unidirectional electromagnetic stirring of the crucible batch of the molten transition material in the crucible, the stirring frequency being lower than the melting frequency, and the stirring power level being lower than the melting power level.

2. The method of claim 1 wherein a direction of rotation of phase shifting the output voltages of each of the separate alternating current power sources is repeatedly reversed so that the unidirectional electromagnetic stirring alternates between reversed flow directions.

3. The method of claim 1 further comprising the step of sequentially removing the output of each one of the separate alternating current power sources from the bottom interior volume to the top interior volume to directionally solidify the crucible batch of the molten transition material in the crucible.

4. The method of claim 1 wherein the stirring frequency is one-half of the melting frequency and/or the stirring power level is one-half of the melting power level.

5. The method of claim 1 wherein phase shifting the output voltages of each of the separate alternating current power sources comprises a 90 degrees counterclockwise-rotation sequential phase shifting between the output voltages of each of the separate alternating current power sources, or a 90 degrees clockwise-rotation sequential phase shifting between the output voltages of each of the separate alternating current power sources.

6. A method of melting a crucible batch of a transition material by gradually adding a solid or semi-solid charge of the transition material to a molten heel of the transition material in a crucible having a lower induction coil exteriorly surrounding a bottom interior volume of the crucible, a first intermediate induction coil exteriorly surrounding a first intermediate interior volume of the crucible disposed above the bottom interior volume, a second intermediate induction coil exteriorly surrounding a second intermediate interior volume of the crucible disposed above the first intermediate induction coil, and an upper induction coil exteriorly surrounding a top interior volume of the crucible disposed above the second intermediate induction coil, the lower, first intermediate, second intermediate, and upper induction coils separately connected to the outputs of a lower, first intermediate, second intermediate and upper alternating current power sources, respectively, the method comprising the steps of:

loading the molten heel of the transition material into at least a bottom portion of the bottom interior volume and adjusting the output of the lower alternating current power source to a melting frequency and a melting power level to keep the molten heel of the transitional material at least at the minimum melting temperature of the transition material;

simultaneously adding the solid or semi-solid charge of the transition material into at least a first intermediate portion of the first intermediate interior volume of the crucible and adjusting the output of the first interme-

12

mediate alternating current power source to the melting frequency and the melting power level while synchronizing the phase of the output voltage of the first intermediate alternating current power source with the phase of the output voltage of the lower alternating current power source;

simultaneously adding the solid or semi-solid charge of the transition material into at least a second intermediate portion of the second intermediate interior volume of the crucible and adjusting the output of the second intermediate alternating current power source to the melting frequency and the melting power level while synchronizing the phase of the output voltage of the second intermediate alternating current power source with the phase of the output voltage of the lower and first intermediate alternating current power sources;

simultaneously adding the solid or semi-solid charge of the transitional material into at least a part of the top interior volume of the crucible to form the crucible batch of transition material and adjusting the output of the upper alternating current power source to the melting frequency and the melting power level while synchronizing the phase of the output voltage of the upper alternating current power source with the phase of the output voltages of the lower, first intermediate, and second intermediate alternating current power sources; and

simultaneously reducing the outputs of the lower, first intermediate, second intermediate and upper alternating current power sources to a stirring frequency and a stirring power level while phase shifting the output voltages of the lower, first intermediate, second intermediate and upper alternating current power sources relative to each other, the stirring frequency being lower than the melting frequency, and the stirring power level being lower than the melting power level.

7. The method of claim 6 wherein a direction of rotation of the phase shifting of the output voltages is repeatedly reversed so that the unidirectional stirring alternates between reversed flow directions of the crucible batch of the transition material in the crucible.

8. The method of claim 6 further comprising of step of sequentially removing the output of the melting power source or the at least one stirring power source from each one of the plurality of induction coils from the bottom to the top of the crucible to directionally solidify the crucible batch of transition material.

9. The method of claim 6 wherein the stirring frequency is approximately one-half of the melting frequency and/or the stirring power is approximately one-half the melting power.

10. The method of claim 6 wherein phase shifting the output voltages of the lower, first intermediate, second intermediate and upper alternating current power sources comprises a 90 degrees counterclockwise-rotation sequential phase shifting between the output voltages of the lower, first intermediate, second intermediate and upper alternating current power sources, or a 90 degrees clockwise-rotation sequential phase shifting between the output voltages of the lower, first intermediate, second intermediate and upper alternating current power sources.