



US009427711B2

(12) **United States Patent**
Terry et al.

(10) **Patent No.:** **US 9,427,711 B2**
(45) **Date of Patent:** **Aug. 30, 2016**

(54) **DISTAL END INSERTED PERSONAL VAPORIZING INHALER CARTRIDGE**

(2013.01); *A61M 2205/3592* (2013.01); *A61M 2205/502* (2013.01); *A61M 2205/52* (2013.01); *A61M 2205/8206* (2013.01); *A61M 2205/8237* (2013.01); *A61M 2209/086* (2013.01)

(71) Applicant: **Minusa Holdings LLC**, Ridgefield, CT (US)

(58) **Field of Classification Search**

CPC .. *A61M 15/06*; *A24F 47/002*; *A24F 47/004*; *A24F 47/006*; *A24F 47/008*
USPC 128/200.11–200.13, 202.21, 128/203.12–203.27, 204.13; 131/273
See application file for complete search history.

(72) Inventors: **Nathan Andrew Terry**, Lowman, ID (US); **Noah Mark Minskoff**, Palo Alto, CA (US)

(73) Assignee: **RAI Strategic Holdings, Inc.**, Winston-Salem, NC (US)

(*) Notice: Subject to any disclaimer, the term of this patent is extended or adjusted under 35 U.S.C. 154(b) by 0 days.

(56) **References Cited**

U.S. PATENT DOCUMENTS

1,771,366 A 7/1930 Wyss et al.
2,057,353 A 10/1936 Whittemore, Jr.
2,104,266 A 1/1938 McCormick

(Continued)

(21) Appl. No.: **14/273,612**

(22) Filed: **May 9, 2014**

FOREIGN PATENT DOCUMENTS

(65) **Prior Publication Data**

US 2014/0246016 A1 Sep. 4, 2014

AU 276250 7/1965
CA 2 641 869 5/2010

(Continued)

Related U.S. Application Data

(63) Continuation of application No. 12/780,873, filed on May 15, 2010.

Primary Examiner — Valerie L Woodward

(74) *Attorney, Agent, or Firm* — Brinks Gilson & Lione

(51) **Int. Cl.**

A61M 15/06 (2006.01)
A61M 11/04 (2006.01)
A24F 47/00 (2006.01)
B01F 3/04 (2006.01)
A61M 15/00 (2006.01)

(57) **ABSTRACT**

A personal vapor inhaling unit is disclosed. An electronic flameless vapor inhaler unit that may simulate a cigarette has a cavity that receives a cartridge in the distal end of the inhaler unit. The cartridge brings a substance to be vaporized in contact with a wick. When the unit is activated, and the user provides suction, the substance to be vaporized is drawn out of the cartridge, through the wick, and is atomized by the wick into a cavity containing a heating element. The heating element vaporizes the atomized substance. The vapors then continue to be pulled by the user through a mouthpiece and mouthpiece cover where they may be inhaled.

(52) **U.S. Cl.**

CPC *B01F 3/04021* (2013.01); *A24F 47/002* (2013.01); *A24F 47/008* (2013.01); *A61M 11/042* (2014.02); *A61M 15/0001* (2014.02); *A61M 15/06* (2013.01); *A61M 2205/13* (2013.01); *A61M 2205/3553* (2013.01); *A61M 2205/3561* (2013.01); *A61M 2205/3584*

17 Claims, 25 Drawing Sheets

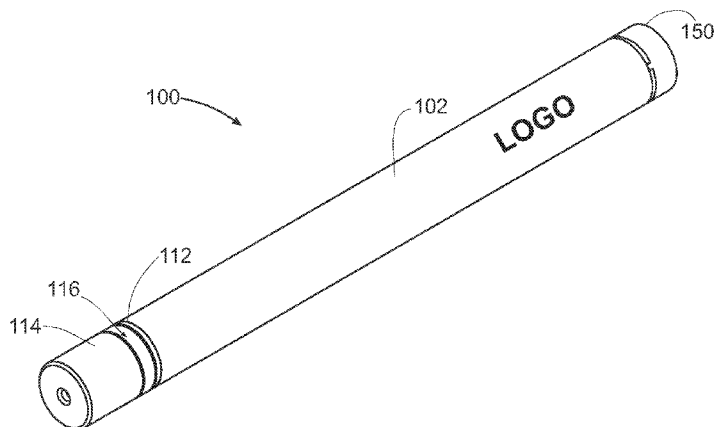

(56)

References Cited

U.S. PATENT DOCUMENTS

2,333,049	A *	10/1943	Shapiro	A24F 25/00 131/300	5,666,977	A	9/1997	Higgins et al.
2,860,638	A *	11/1958	Bartolomeo	128/202.21	5,666,978	A	9/1997	Counts et al.
3,200,819	A	8/1965	Gilbert		5,687,746	A	11/1997	Rose et al.
3,751,969	A	8/1973	Schrock		5,692,525	A	12/1997	Counts et al.
4,219,032	A	8/1980	Tabatznik et al.		5,692,526	A	12/1997	Adams et al.
4,259,970	A	4/1981	Green, Jr.		5,708,258	A	1/1998	Counts et al.
4,284,089	A	8/1981	Ray		5,709,202	A	1/1998	Lloyd et al.
4,303,083	A	12/1981	Burruss, Jr.		5,726,421	A	3/1998	Fleischhauer et al.
4,429,703	A	2/1984	Haber		5,730,158	A	3/1998	Collins et al.
4,708,151	A	11/1987	Shelar		5,743,251	A	4/1998	Howell et al.
4,714,082	A	12/1987	Banerjee et al.		5,750,964	A	5/1998	Counts et al.
4,735,217	A	4/1988	Gerth et al.		5,799,663	A	9/1998	Gross et al.
4,756,318	A	7/1988	Clearman et al.		5,816,263	A	10/1998	Counts et al.
4,771,795	A	9/1988	White et al.		5,819,756	A	10/1998	Mielordt
4,776,353	A	10/1988	Lilja et al.		5,865,185	A	2/1999	Collins et al.
4,793,365	A	12/1988	Sensabaugh, Jr. et al.		5,865,186	A	2/1999	Volsley, II
4,819,665	A	4/1989	Roberts et al.		5,878,752	A	3/1999	Adams et al.
4,848,374	A	7/1989	Chard et al.		5,893,371	A	4/1999	Rose et al.
4,848,376	A	7/1989	Lilja et al.		5,894,841	A	4/1999	Voges
4,907,606	A	3/1990	Lilja et al.		5,915,387	A	6/1999	Baggett, Jr. et al.
4,913,168	A	4/1990	Potter et al.		5,934,289	A	8/1999	Watkins et al.
4,917,119	A	4/1990	Potter et al.		5,954,979	A	9/1999	Counts et al.
4,922,901	A	5/1990	Brooks et al.		5,967,148	A	10/1999	Harris et al.
4,938,236	A	7/1990	Banerjee et al.		6,026,820	A	2/2000	Baggett, Jr. et al.
4,941,483	A	7/1990	Ridings et al.		6,040,560	A	3/2000	Fleischhauer et al.
4,945,931	A	8/1990	Gori		6,053,176	A	4/2000	Adams et al.
4,947,874	A	8/1990	Brooks et al.		6,089,857	A	7/2000	Matsuura et al.
4,986,286	A	1/1991	Roberts et al.		6,095,153	A	8/2000	Kessler et al.
5,019,122	A	5/1991	Clearman et al.		6,116,247	A	9/2000	Banyasz et al.
5,042,510	A	8/1991	Curtiss et al.		6,119,700	A	9/2000	Fleischhauer et al.
5,060,671	A	10/1991	Counts et al.		6,125,853	A	10/2000	Susa et al.
5,093,894	A	3/1992	Deevi et al.		6,125,866	A	10/2000	Nichols et al.
5,095,921	A	3/1992	Losee et al.		6,155,268	A	12/2000	Takeuchi
5,097,850	A	3/1992	Braunshsteyn et al.		6,164,287	A	12/2000	White
5,144,962	A	9/1992	Counts et al.		6,196,218	B1	3/2001	Voges
5,159,940	A	11/1992	Hayward et al.		6,196,219	B1	3/2001	Hess et al.
5,179,966	A	1/1993	Losee et al.		6,349,728	B1	2/2002	Pham
5,211,684	A	5/1993	Shannon et al.		6,418,938	B1	7/2002	Fleischhauer et al.
5,224,498	A	7/1993	Deevi et al.		6,443,146	B1	9/2002	Voges
5,228,460	A	7/1993	Sprinkel, Jr. et al.		6,446,426	B1	9/2002	Sweeney et al.
5,246,018	A	9/1993	Deevi et al.		6,557,552	B1	5/2003	Cox et al.
5,249,586	A	10/1993	Morgan et al.		6,598,607	B2	7/2003	Adiga et al.
5,261,424	A	11/1993	Sprinkel, Jr.		6,601,776	B1	8/2003	Olijaca et al.
5,269,327	A	12/1993	Counts et al.		6,615,840	B1	9/2003	Fournier et al.
5,285,798	A	2/1994	Banerjee et al.		6,681,769	B2	1/2004	Sprinkel, Jr. et al.
5,322,075	A	6/1994	Deevi et al.		6,688,313	B2	2/2004	Wrenn et al.
5,345,951	A	9/1994	Serrano et al.		6,715,494	B1	4/2004	McCoy
5,353,813	A	10/1994	Deevi et al.		6,766,220	B2	7/2004	McRae et al.
5,366,122	A	11/1994	Guentert et al.		6,772,756	B2	8/2004	Shayan
5,369,723	A	11/1994	Counts et al.		6,772,757	B2	8/2004	Sprinkel, Jr. et al.
5,372,148	A	12/1994	McCafferty et al.		6,803,545	B2	10/2004	Blake et al.
5,388,574	A	2/1995	Ingebretsen		6,803,550	B2	10/2004	Sharpe et al.
5,388,594	A	2/1995	Counts et al.		6,804,458	B2	10/2004	Sherwood et al.
5,408,574	A	4/1995	Deevi et al.		6,810,883	B2	11/2004	Felter et al.
5,468,936	A	11/1995	Deevi et al.		6,854,461	B2	2/2005	Nichols et al.
5,479,948	A	1/1996	Counts et al.		6,854,470	B1	2/2005	Pa
5,498,850	A	3/1996	Das		6,923,179	B2	8/2005	Gupta et al.
5,498,855	A	3/1996	Deevi et al.		6,994,096	B2	2/2006	Rostami et al.
5,499,636	A	3/1996	Baggett, Jr. et al.		7,040,314	B2	5/2006	Nguyen et al.
5,505,214	A	4/1996	Collins et al.		7,117,867	B2	10/2006	Cox et al.
5,515,842	A	5/1996	Ramseyer et al.		7,147,170	B2	12/2006	Nguyen et al.
5,530,225	A	6/1996	Hajaligol		7,163,015	B2	1/2007	Moffitt
5,551,451	A	9/1996	Riggs et al.		7,167,776	B2	1/2007	Maharajh et al.
5,564,442	A	10/1996	MacDonald et al.		7,173,222	B2	2/2007	Cox et al.
5,573,692	A	11/1996	Das et al.		7,185,659	B2	3/2007	Sharpe et al.
5,591,368	A	1/1997	Fleischhauer et al.		7,234,470	B2	6/2007	Yang
5,595,706	A	1/1997	Sikk et al.		7,290,549	B2	11/2007	Banerjee et al.
5,611,360	A	3/1997	Tang		7,293,565	B2	11/2007	Griffin et al.
5,613,504	A	3/1997	Collins et al.		7,392,809	B2	7/2008	Larson et al.
5,613,505	A	3/1997	Campbell et al.		7,400,940	B2	7/2008	McRae et al.
5,649,554	A	7/1997	Sprinkel et al.		7,500,479	B2	3/2009	Nichols et al.
5,659,656	A	8/1997	Das		D590,988	S	4/2009	Hon
5,665,262	A	9/1997	Hajaligol et al.		D590,989	S	4/2009	Hon
5,666,976	A	9/1997	Adams et al.		D590,990	S	4/2009	Hon
					D590,991	S	4/2009	Hon
					7,645,442	B2	1/2010	Hale et al.
					D614,346	S	4/2010	Lik
					7,690,385	B2	4/2010	Moffitt
					7,692,123	B2	4/2010	Baba et al.

(56)

References Cited

U.S. PATENT DOCUMENTS

7,726,320 B2 *	6/2010	Robinson et al.	131/200	D699,391 S	2/2014	Abroff et al.	
7,810,505 B2	10/2010	Yang		D700,397 S	2/2014	Manca et al.	
7,832,410 B2 *	11/2010	Hon	131/273	D700,738 S	3/2014	Rennick et al.	
7,845,359 B2	12/2010	Montaser		D700,739 S	3/2014	Manca et al.	
7,983,113 B2	7/2011	Krueger et al.		D700,994 S	3/2014	Alarcon et al.	
D644,375 S	8/2011	Zhou		8,678,012 B2	3/2014	Li et al.	
7,997,280 B2	8/2011	Rosenthal		D702,876 S	4/2014	Liu	
8,003,080 B2	8/2011	Rabinowitz et al.		8,689,786 B2	4/2014	Schennum	
8,042,550 B2	10/2011	Urtsev et al.		8,689,804 B2	4/2014	Fernando et al.	
D649,708 S	11/2011	O'Neil		8,689,805 B2	4/2014	Hon	
8,079,371 B2	12/2011	Robinson et al.		8,695,794 B2	4/2014	Scatterday	
8,091,558 B2	1/2012	Martzel		8,707,965 B2	4/2014	Newton	
D653,803 S	2/2012	Timmermans		D704,549 S	5/2014	Liu	
D655,036 S	2/2012	Zhou		D704,629 S	5/2014	Liu	
8,127,772 B2	3/2012	Montaser		D704,630 S	5/2014	Liu	
D657,047 S	4/2012	Minskoff et al.		D705,814 S	5/2014	Liberti et al.	
8,156,944 B2	4/2012	Hon		8,714,161 B2	5/2014	Liu	
D662,257 S	6/2012	Alelov		8,733,345 B2	5/2014	Siller	
8,191,555 B2	6/2012	Herbrich		8,733,346 B2	5/2014	Rinker	
8,205,622 B2	6/2012	Pan		D706,976 S	6/2014	Wu	
D666,355 S	8/2012	Alelov		D707,389 S	6/2014	Liu	
8,291,918 B2	10/2012	Magnon		8,746,240 B2	6/2014	Terry et al.	
8,314,591 B2	11/2012	Terry et al.		8,752,557 B2	6/2014	Lipowicz	
8,322,350 B2	12/2012	Lipowicz		8,757,169 B2	6/2014	Gysland	
8,342,184 B2	1/2013	Inagaki et al.		8,893,726 B2	11/2014	Hon	
D675,777 S	2/2013	Wu		2002/0136886 A1	9/2002	He et al.	
D677,000 S	2/2013	Liu		2004/0020500 A1	2/2004	Wrenn et al.	
D677,001 S	2/2013	Liu		2004/0055613 A1	3/2004	Horian	
8,365,742 B2	2/2013	Hon		2004/0084044 A1	5/2004	Childers et al.	
8,371,310 B2	2/2013	Brenneise		2004/0089314 A1	5/2004	Felter et al.	
8,375,957 B2 *	2/2013	Hon	131/194	2004/0129280 A1	7/2004	Woodson et al.	
8,393,331 B2	3/2013	Hon		2004/0149296 A1	8/2004	Rostami et al.	
8,402,976 B2	3/2013	Fernando et al.		2004/0200488 A1	10/2004	Felter et al.	
D681,268 S	4/2013	Wu		2004/0226568 A1	11/2004	Takeuchi et al.	
D681,269 S	4/2013	Wu		2005/0016550 A1	1/2005	Katase	
8,430,106 B2	4/2013	Potter et al.		2005/0172976 A1	8/2005	Newman et al.	
D682,090 S	5/2013	Scatterday		2006/0016453 A1	1/2006	Kim	
D682,465 S	5/2013	Yeom		2006/0021614 A1	2/2006	Wermeling et al.	
8,434,478 B2	5/2013	Yamada et al.		2006/0070633 A1	4/2006	Rostami et al.	
D683,897 S	6/2013	Liu		2006/0130857 A1 *	6/2006	Roth et al.	131/273
D683,898 S	6/2013	Liu		2006/0185687 A1	8/2006	Hearn et al.	
D683,899 S	6/2013	Liu		2006/0196518 A1	9/2006	Hon	
D684,311 S	6/2013	Liu		2006/0283468 A1	12/2006	Lipowicz	
8,459,271 B2	6/2013	Inagaki		2007/0074734 A1	4/2007	Braunshsteyn et al.	
D685,522 S	7/2013	Potter et al.		2007/0102013 A1	5/2007	Adams et al.	
8,479,747 B2	7/2013	O'Connell		2007/0240711 A1	10/2007	Hamano	
8,490,628 B2	7/2013	Hon		2007/0267031 A1	11/2007	Hon	
8,495,998 B2	7/2013	Schennum		2007/0283972 A1	12/2007	Monsees et al.	
D687,999 S	8/2013	Liu		2008/0056691 A1	3/2008	Wingo et al.	
D688,415 S	8/2013	Kim		2008/0099011 A1	5/2008	Gonda et al.	
D688,416 S	8/2013	Liu		2008/0149118 A1	6/2008	Oglesby et al.	
D688,418 S	8/2013	Liu		2008/0241255 A1 *	10/2008	Rose et al.	424/489
8,499,766 B1	8/2013	Newton		2008/0257367 A1	10/2008	Paterno et al.	
8,505,548 B2	8/2013	Hearn		2008/0302374 A1	12/2008	Wengert et al.	
8,511,318 B2	8/2013	Hon		2009/0065010 A1	3/2009	Shands	
8,517,032 B2	8/2013	Urtsev et al.		2009/0095311 A1 *	4/2009	Han	131/194
8,528,569 B1	9/2013	Newton		2009/0114737 A1	5/2009	Yu et al.	
8,539,959 B1	9/2013	Scatterday		2009/0126745 A1	5/2009	Hon	
D691,324 S	10/2013	Saliman		2009/0151717 A1	6/2009	Bowen et al.	
D692,612 S	10/2013	Lowenthal et al.		2009/0178672 A1	7/2009	Mullinger et al.	
D692,614 S	10/2013	Robinson		2009/0188490 A1	7/2009	Han	
D692,615 S	10/2013	Verleur		2009/0230117 A1	9/2009	Fernando et al.	
8,550,068 B2	10/2013	Terry et al.		2009/0255534 A1 *	10/2009	Paterno	128/203.21
8,550,069 B2	10/2013	Alelov		2009/0260641 A1	10/2009	Monsees et al.	
8,558,147 B2	10/2013	Greim et al.		2009/0260642 A1	10/2009	Monsees et al.	
D693,054 S	11/2013	Verleur		2009/0272379 A1 *	11/2009	Thorens et al.	128/202.21
D693,055 S	11/2013	Manca		2009/0283103 A1 *	11/2009	Nielsen et al.	131/273
8,578,942 B2	11/2013	Schennum		2009/0293892 A1	12/2009	Williams et al.	
D696,051 S	12/2013	Scatterday		2010/0024834 A1	2/2010	Oglesby et al.	
D696,455 S	12/2013	Abroff		2010/0031968 A1 *	2/2010	Sheikh et al.	131/347
D696,815 S	12/2013	Abroff		2010/0059073 A1	3/2010	Hoffmann et al.	
8,596,460 B2	12/2013	Scatterday		2010/0083959 A1	4/2010	Siller	
8,602,037 B2	12/2013	Inagaki		2010/0126505 A1	5/2010	Rinker	
D697,482 S	1/2014	Cheng		2010/0163063 A1	7/2010	Fernando et al.	
8,634,709 B2	1/2014	Maharajh et al.		2010/0242974 A1 *	9/2010	Pan	131/273
				2010/0242975 A1	9/2010	Hearn	
				2010/0242976 A1	9/2010	Katayama et al.	
				2010/0300467 A1	12/2010	Kuistila et al.	
				2010/0307518 A1	12/2010	Wang	

(56)

References Cited

U.S. PATENT DOCUMENTS

2010/0313901	A1	12/2010	Fernando et al.	2013/0146489	A1	6/2013	Scatterday
2011/0005535	A1	1/2011	Xiu	2013/0152954	A1	6/2013	Youn
2011/0011396	A1	1/2011	Fang	2013/0160764	A1	6/2013	Liu
2011/0036365	A1	2/2011	Chong et al.	2013/0160765	A1	6/2013	Liu
2011/0094523	A1	4/2011	Thorens et al.	2013/0167853	A1	7/2013	Liu
2011/0126848	A1	6/2011	Zuber et al.	2013/0167854	A1	7/2013	Shin
2011/0147486	A1	6/2011	Greim et al.	2013/0169230	A1	7/2013	Li et al.
2011/0155153	A1	6/2011	Thorens et al.	2013/0180533	A1	7/2013	Kim et al.
2011/0162663	A1	7/2011	Bryman	2013/0192615	A1	8/2013	Tucker et al.
2011/0226236	A1	9/2011	Buchberger	2013/0192616	A1	8/2013	Tucker et al.
2011/0232654	A1	9/2011	Maas	2013/0192617	A1	8/2013	Thompson
2011/0265806	A1	11/2011	Alarcon et al.	2013/0192618	A1	8/2013	Li
2011/0277760	A1	11/2011	Terry et al.	2013/0192619	A1	8/2013	Tucker et al.
2011/0277761	A1	11/2011	Terry et al.	2013/0192620	A1	8/2013	Tucker et al.
2011/0277764	A1	11/2011	Terry et al.	2013/0192621	A1	8/2013	Li et al.
2011/0277780	A1	11/2011	Terry et al.	2013/0192622	A1	8/2013	Tucker et al.
2011/0290244	A1	12/2011	Schennum	2013/0192623	A1	8/2013	Tucker et al.
2011/0290248	A1	12/2011	Schennum	2013/0199528	A1	8/2013	Goodman et al.
2011/0290266	A1	12/2011	Köller	2013/0206154	A1	8/2013	Fernando et al.
2011/0290267	A1	12/2011	Yamada et al.	2013/0213417	A1	8/2013	Chong et al.
2011/0290269	A1	12/2011	Shimizu et al.	2013/0213418	A1	8/2013	Tucker et al.
2011/0297166	A1	12/2011	Takeuchi et al.	2013/0213419	A1	8/2013	Tucker et al.
2011/0304282	A1	12/2011	Li et al.	2013/0213420	A1	8/2013	Hon
2011/0309157	A1	12/2011	Yang et al.	2013/0220315	A1	8/2013	Conley et al.
2012/0006342	A1	1/2012	Rose et al.	2013/0220316	A1	8/2013	Oglesby et al.
2012/0006343	A1	1/2012	Renaud et al.	2013/0228190	A1	9/2013	Weiss et al.
2012/0111346	A1	5/2012	Rinker	2013/0243410	A1	9/2013	Nichols et al.
2012/0111347	A1	5/2012	Hon	2013/0247924	A1	9/2013	Scatterday et al.
2012/0118301	A1	5/2012	Montaser	2013/0248385	A1	9/2013	Scatterday et al.
2012/0118307	A1	5/2012	Tu	2013/0255675	A1	10/2013	Liu
2012/0138052	A1	6/2012	Hearn et al.	2013/0263869	A1	10/2013	Zhu
2012/0138054	A1	6/2012	Hearn et al.	2013/0276798	A1	10/2013	Hon
2012/0145169	A1	6/2012	Wu	2013/0276799	A1	10/2013	Davidson et al.
2012/0152244	A1	6/2012	Yomtov	2013/0276802	A1	10/2013	Scatterday
2012/0152246	A1	6/2012	Yomtov	2013/0276804	A1	10/2013	Hon
2012/0160251	A1	6/2012	Hammel et al.	2013/0284190	A1	10/2013	Scatterday
2012/0167906	A1	7/2012	Gysland	2013/0284191	A1	10/2013	Scatterday
2012/0186594	A1	7/2012	Liu	2013/0284192	A1	10/2013	Peleg et al.
2012/0199146	A1	8/2012	Marangos	2013/0284194	A1	10/2013	Newton
2012/0199663	A1	8/2012	Qiu	2013/0298905	A1	11/2013	Levin et al.
2012/0204889	A1	8/2012	Xiu	2013/0298922	A1	11/2013	Xiang
2012/0211015	A1	8/2012	Hon	2013/0300350	A1	11/2013	Xiang
2012/0227752	A1	9/2012	Alelov	2013/0306064	A1	11/2013	Thorens et al.
2012/0234315	A1	9/2012	Hon	2013/0306065	A1	11/2013	Thorens et al.
2012/0247494	A1	10/2012	Oglesby et al.	2013/0306084	A1	11/2013	Flick
2012/0255567	A1	10/2012	Rose	2013/0306692	A1	11/2013	Mangum et al.
2012/0260926	A1	10/2012	Tu	2013/0312739	A1	11/2013	Rome et al.
2012/0260927	A1	10/2012	Liu	2013/0312742	A1	11/2013	Monsees
2012/0273589	A1	11/2012	Hon	2013/0313139	A1	11/2013	Scatterday
2012/0285475	A1	11/2012	Liu	2013/0319404	A1	12/2013	Feriani et al.
2012/0298123	A1	11/2012	Woodcock et al.	2013/0319407	A1	12/2013	Liu
2012/0312313	A1	12/2012	Frija	2013/0319431	A1	12/2013	Cyphert et al.
2012/0318882	A1	12/2012	Abehasera	2013/0319435	A1	12/2013	Flick
2012/0325227	A1	12/2012	Robinson et al.	2013/0319436	A1	12/2013	Liu
2012/0325228	A1	12/2012	Williams	2013/0319438	A1	12/2013	Liu
2013/0008457	A1	1/2013	Zheng et al.	2013/0319439	A1	12/2013	Gorelick et al.
2013/0019862	A1	1/2013	Yamada et al.	2013/0319440	A1	12/2013	Capuano
2013/0019887	A1	1/2013	Liu	2013/0319989	A1	12/2013	Liu
2013/0025609	A1	1/2013	Liu	2013/0319999	A1	12/2013	Plojoux et al.
2013/0037041	A1	2/2013	Worm et al.	2013/0333700	A1	12/2013	Buchberger
2013/0037042	A1	2/2013	Hearn et al.	2013/0333711	A1	12/2013	Liu
2013/0042865	A1	2/2013	Monsees et al.	2013/0333712	A1	12/2013	Scatterday
2013/0056012	A1	3/2013	Hearn et al.	2013/0336358	A1	12/2013	Liu
2013/0056013	A1	3/2013	Terry et al.	2013/0340750	A1	12/2013	Thorens et al.
2013/0061861	A1	3/2013	Hearn	2013/0340775	A1	12/2013	Juster et al.
2013/0068239	A1	3/2013	Youn	2013/0340778	A1	12/2013	Liu
2013/0074854	A1	3/2013	Lipowicz	2013/0340779	A1	12/2013	Liu
2013/0074857	A1	3/2013	Buchberger	2013/0341218	A1	12/2013	Liu
2013/0081623	A1	4/2013	Buchberger	2013/0342157	A1	12/2013	Liu
2013/0081642	A1	4/2013	Safari	2014/0000636	A1	1/2014	O'Connell
2013/0087160	A1	4/2013	Gherghe	2014/0000637	A1	1/2014	O'Connell
2013/0104916	A1	5/2013	Bellinger et al.	2014/0000638	A1	1/2014	Sebastian et al.
2013/0125906	A1	5/2013	Hon	2014/0007891	A1	1/2014	Liu
2013/0139833	A1	6/2013	Hon	2014/0007892	A1	1/2014	Liu
2013/0140200	A1	6/2013	Scatterday	2014/0014124	A1	1/2014	Glasberg et al.
				2014/0014125	A1	1/2014	Fernando et al.
				2014/0014126	A1	1/2014	Peleg et al.
				2014/0020693	A1	1/2014	Thorens et al.
				2014/0020696	A1	1/2014	Liu

(56)

References Cited

U.S. PATENT DOCUMENTS

2014/0020697 A1 1/2014 Liu
 2014/0034070 A1 2/2014 Schennum
 2014/0034071 A1 2/2014 Levitz et al.
 2014/0041655 A1 2/2014 Barron et al.
 2014/0044857 A1 2/2014 Hua et al.
 2014/0048086 A1 2/2014 Zhanghua
 2014/0048444 A1 2/2014 Scatterday
 2014/0053856 A1 2/2014 Liu
 2014/0053857 A1 2/2014 Liu
 2014/0053858 A1 2/2014 Liu
 2014/0060524 A1 3/2014 Liu
 2014/0060527 A1 3/2014 Liu
 2014/0060528 A1 3/2014 Liu
 2014/0060529 A1 3/2014 Zhang
 2014/0060554 A1 3/2014 Collett et al.
 2014/0060555 A1 3/2014 Chang et al.
 2014/0060556 A1 3/2014 Liu
 2014/0062417 A1 3/2014 Li
 2014/0069424 A1 3/2014 Poston et al.
 2014/0069425 A1 3/2014 Zhang
 2014/0069444 A1 3/2014 Cyphert et al.
 2014/0076310 A1 3/2014 Newton
 2014/0083442 A1 3/2014 Scatterday
 2014/0083443 A1 3/2014 Liu
 2014/0096781 A1 4/2014 Sears et al.
 2014/0096782 A1 4/2014 Ampolini et al.
 2014/0102463 A1 4/2014 Jones
 2014/0103020 A1 4/2014 Al-Qaffas
 2014/0107815 A1 4/2014 Lamothe
 2014/0109898 A1 4/2014 Li
 2014/0109905 A1 4/2014 Yamada et al.
 2014/0109921 A1 4/2014 Chen
 2014/0116455 A1 5/2014 Youn
 2014/0123989 A1 5/2014 Lamothe
 2014/0123990 A1 5/2014 Timmermans
 2014/0130796 A1 5/2014 Liu
 2014/0130797 A1 5/2014 Liu
 2014/0130816 A1 5/2014 Liu
 2014/0130817 A1 5/2014 Li
 2014/0144453 A1 5/2014 Capuano et al.
 2014/0150783 A1 6/2014 Liu
 2014/0150784 A1 6/2014 Liu

2014/0150785 A1 6/2014 Malik et al.
 2014/0150810 A1 6/2014 Hon
 2014/0157583 A1 6/2014 Ward et al.
 2014/0166027 A1 6/2014 Fuisz et al.
 2014/0166028 A1 6/2014 Fuisz et al.
 2014/0166029 A1 6/2014 Weigensberg et al.
 2014/0166030 A1 6/2014 Li
 2014/0174459 A1 6/2014 Burstyn
 2014/0174968 A1 6/2014 Scatterday
 2014/0182608 A1 7/2014 Egoiyants et al.
 2014/0182610 A1 7/2014 Liu
 2014/0182611 A1 7/2014 Liu
 2014/0182612 A1 7/2014 Chen
 2014/0186015 A1 7/2014 Breiwa, III
 2014/0196736 A1 7/2014 Fernando et al.
 2014/0299125 A1 10/2014 Buchberger
 2014/0305453 A1 10/2014 Hon
 2014/0318560 A1 10/2014 Hon

FOREIGN PATENT DOCUMENTS

CN 200997909 1/2008
 CN 101116542 2/2008
 CN 101176805 5/2008
 DE 10 2006 004 484 8/2007
 DE 102006041042 3/2008
 DE 20 2009 010 400 11/2009
 EP 0 295 122 12/1988
 EP 0 430 566 6/1991
 EP 0 845 220 6/1998
 EP 1 618 803 1/2006
 EP 2 316 286 5/2011
 GB 2469850 11/2010
 WO WO 97/48293 12/1997
 WO WO 2007/078273 7/2007
 WO WO 2007/131449 11/2007
 WO WO 2010/003480 1/2010
 WO WO 2010/118644 10/2010
 WO WO 2010/140937 12/2010
 WO WO 2011/010334 1/2011
 WO WO 2012/072762 6/2012
 WO WO 2012/100523 8/2012
 WO WO 2013/089551 6/2013

* cited by examiner

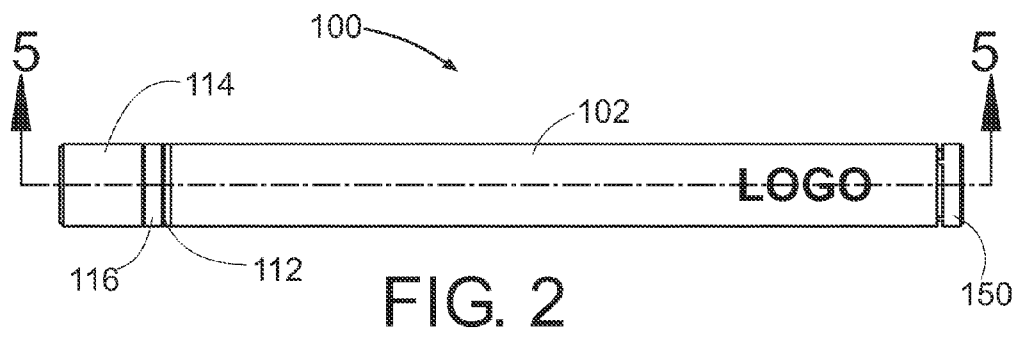
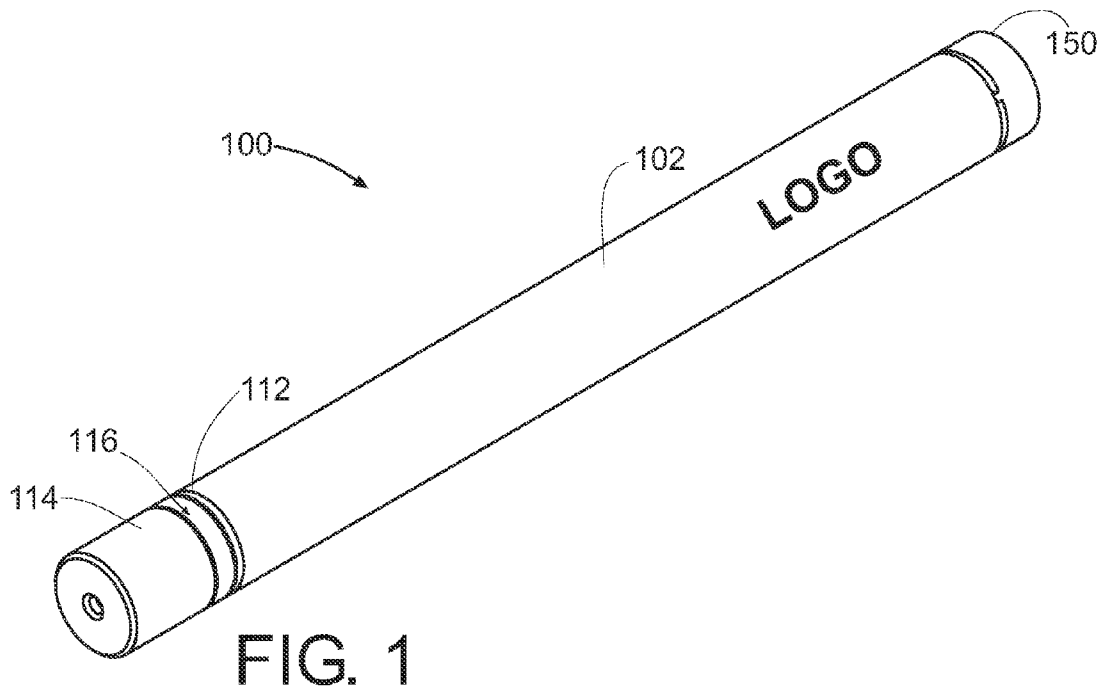

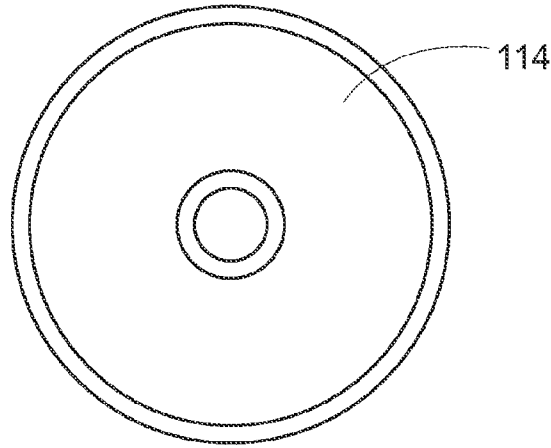

FIG. 3

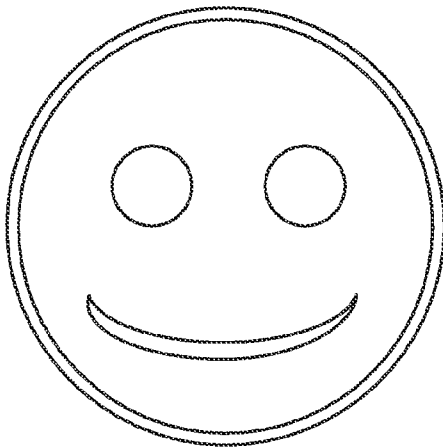

FIG. 4A

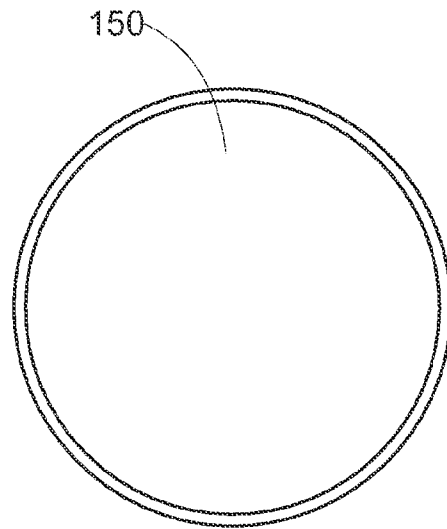

FIG. 4

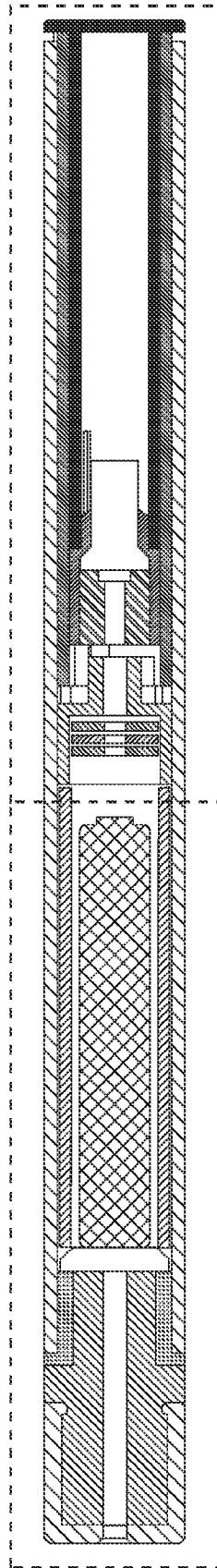

FIG. 5

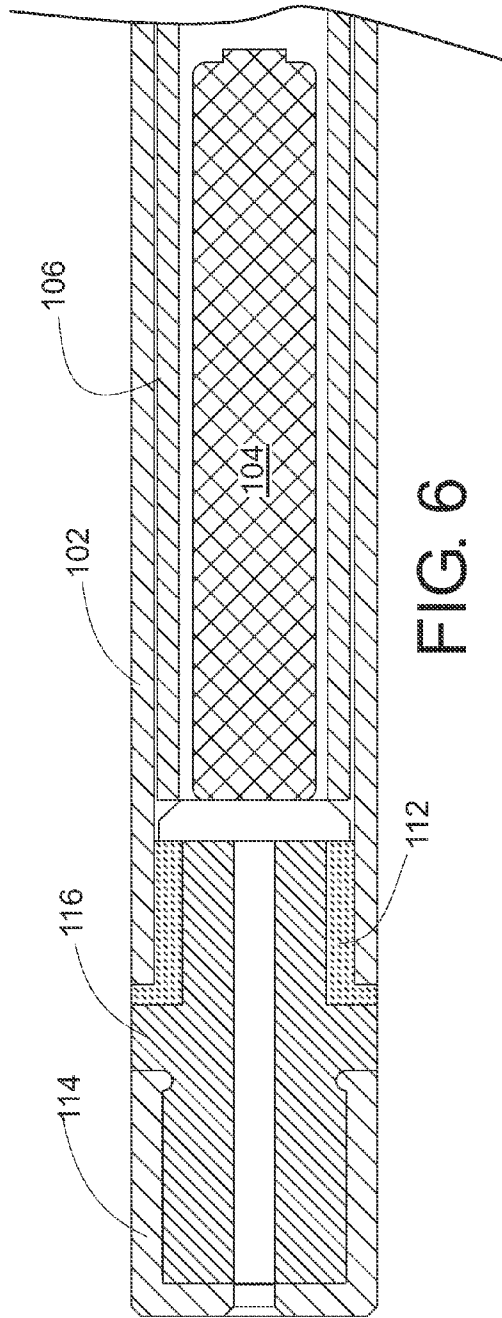

FIG. 6

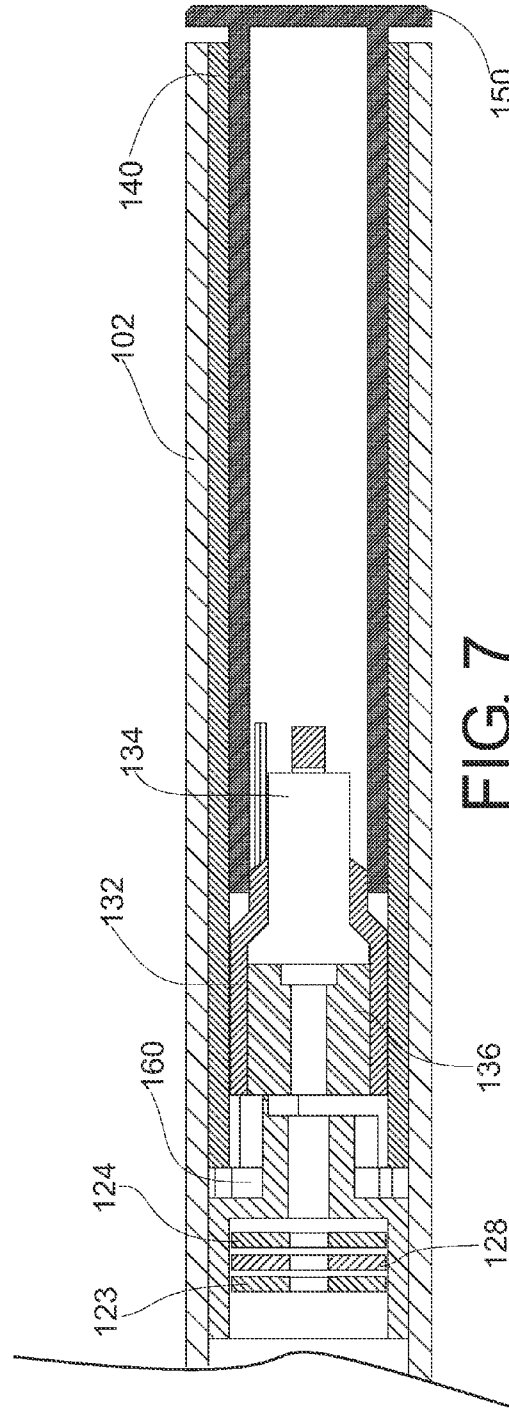

FIG. 7

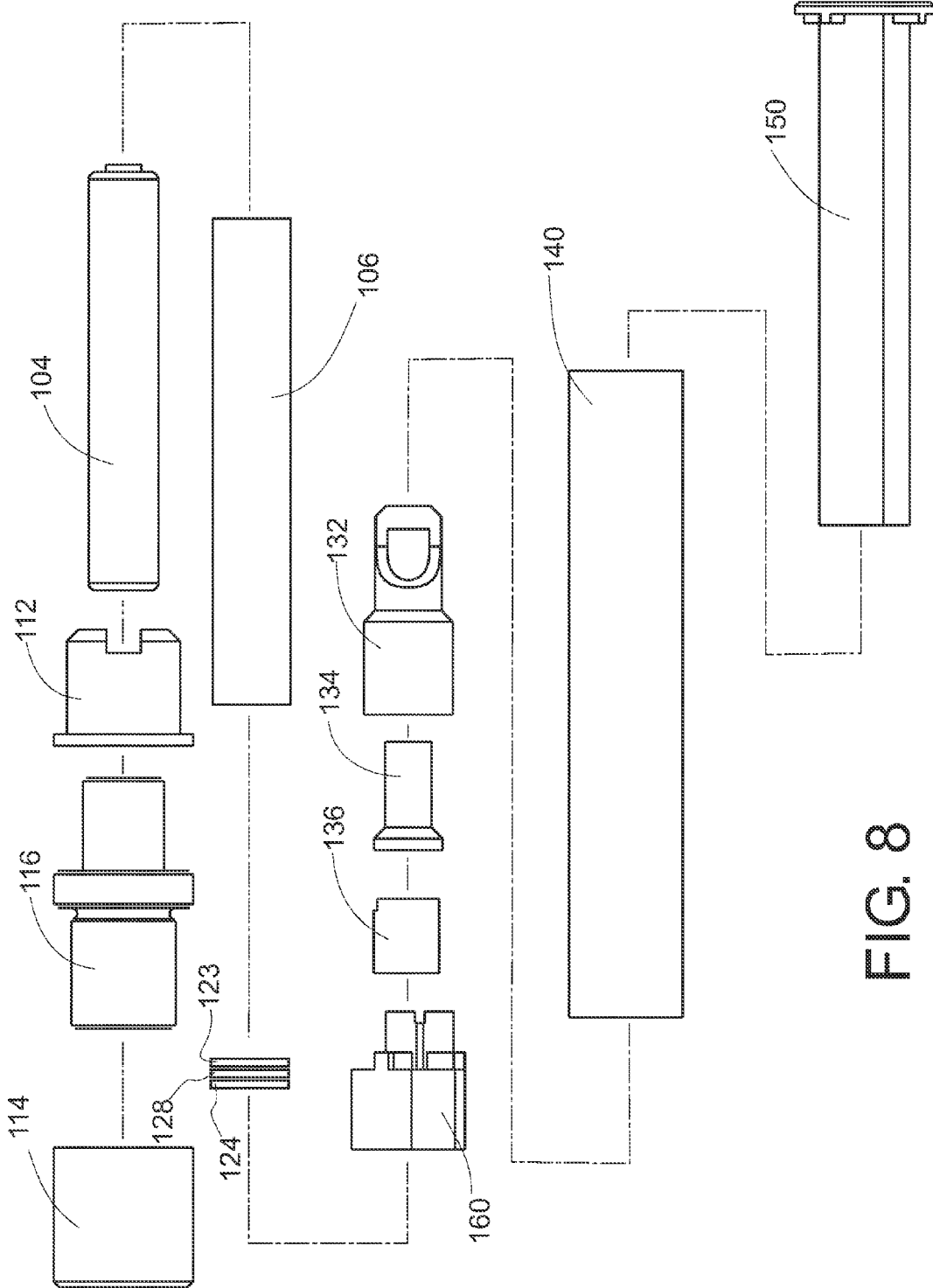

FIG. 8

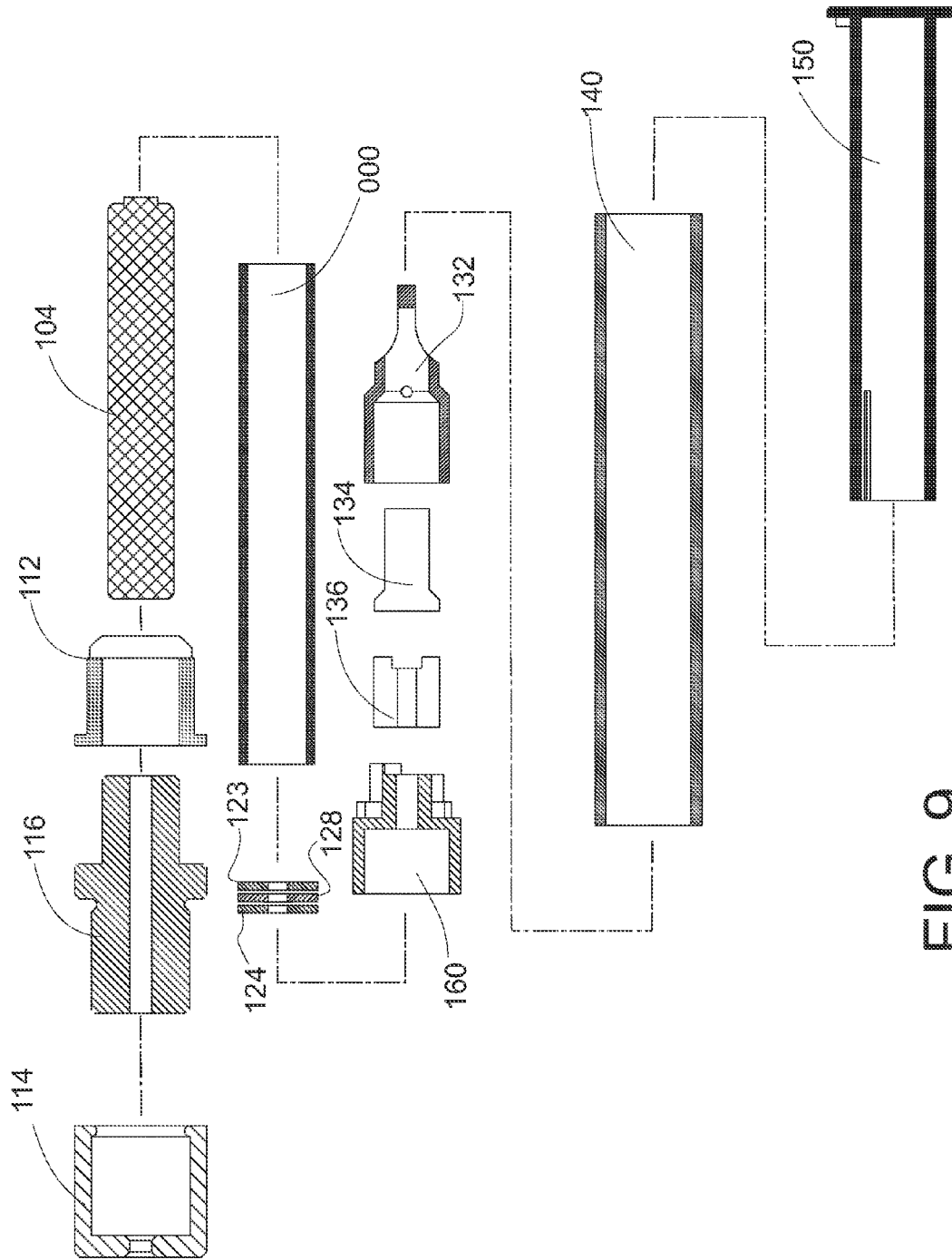

FIG. 9

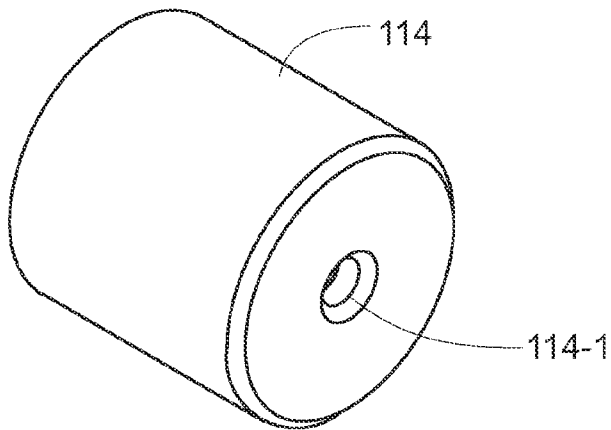

FIG. 10

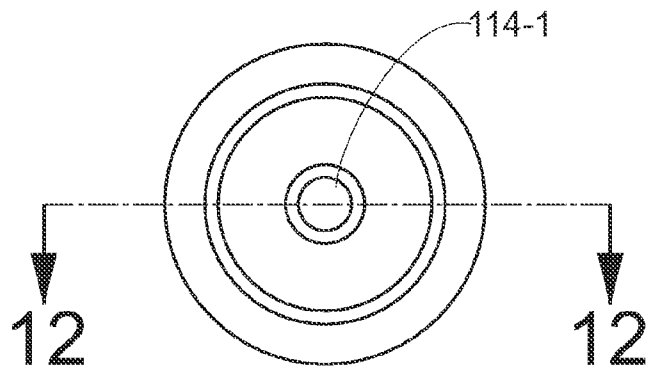

FIG. 11

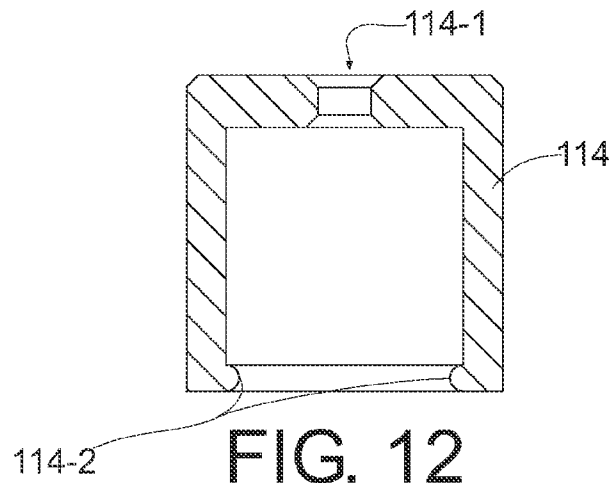

FIG. 12

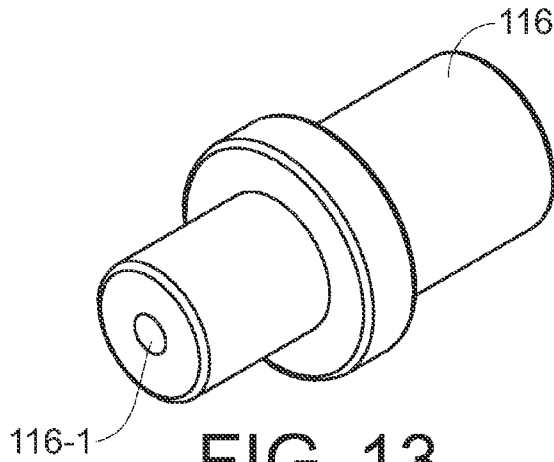

FIG. 13

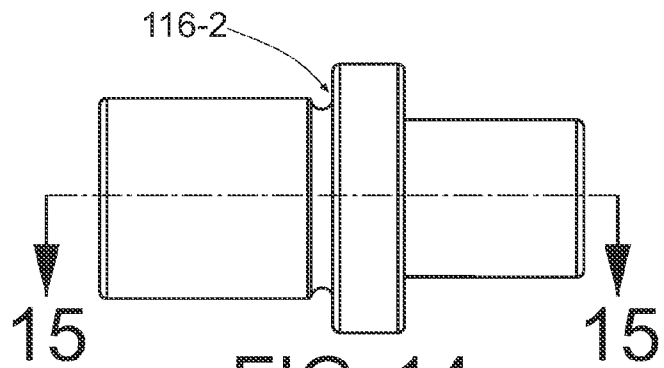

FIG. 14

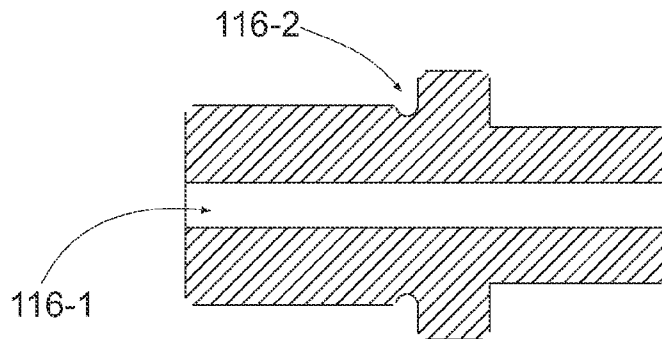

FIG. 15

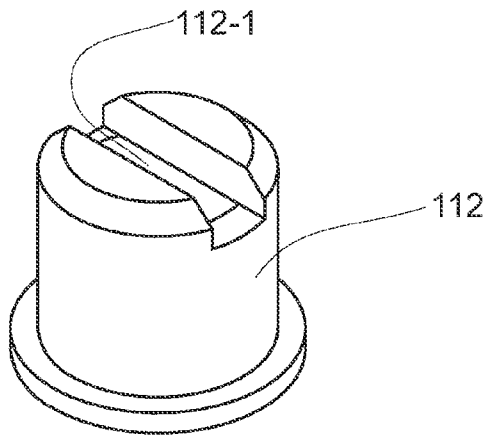

FIG. 16

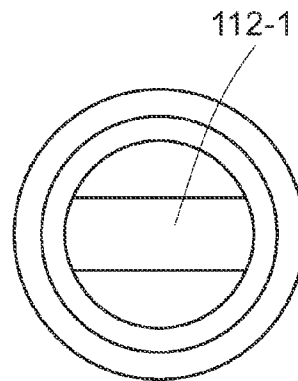

FIG. 17

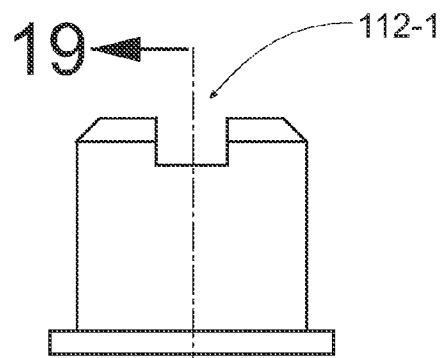

FIG. 18

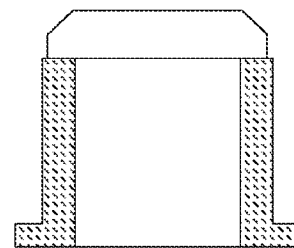

FIG. 19

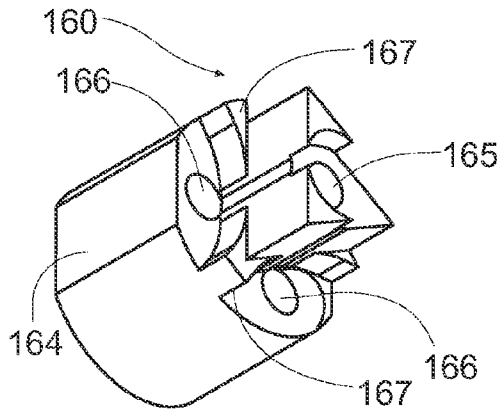

FIG. 20

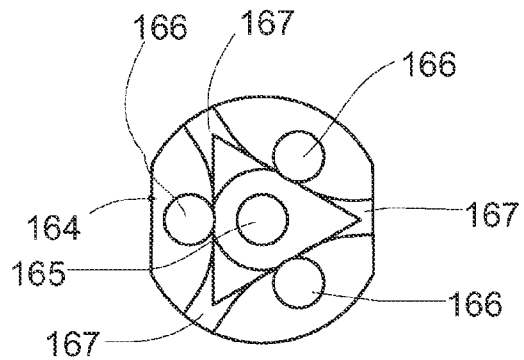

FIG. 21

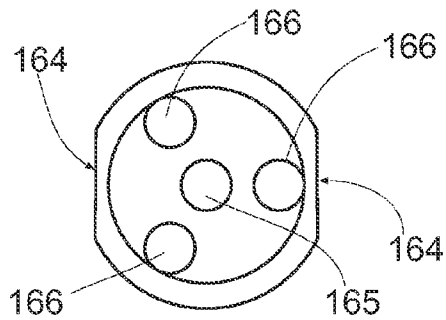

FIG. 22

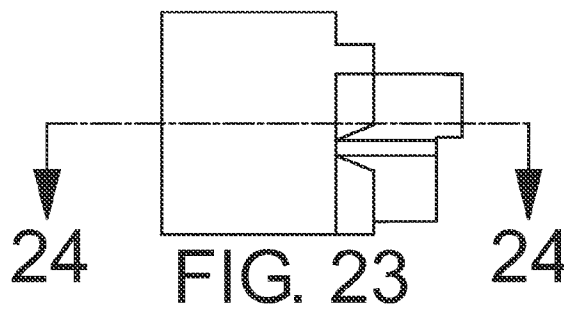

FIG. 23

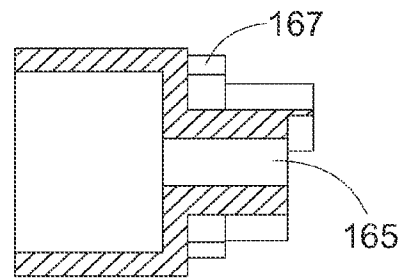

FIG. 24

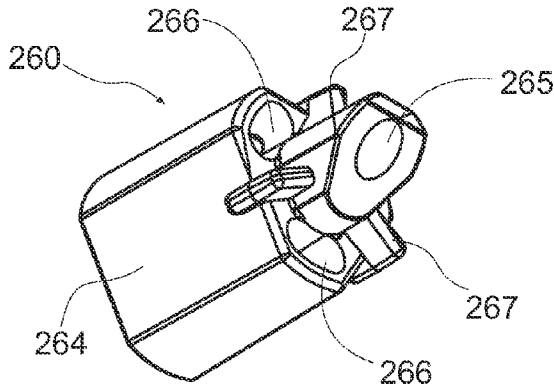

FIG. 25

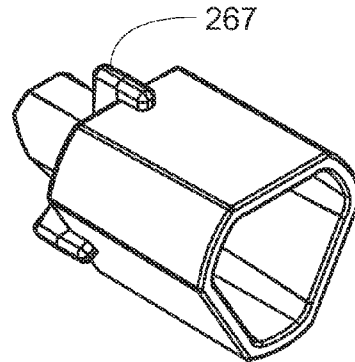

FIG. 26

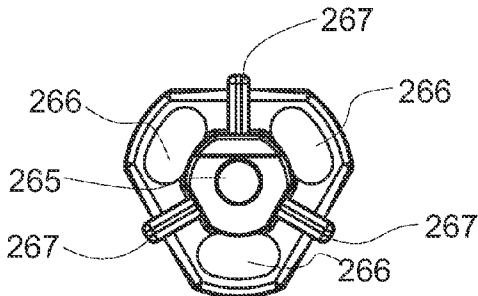

FIG. 27

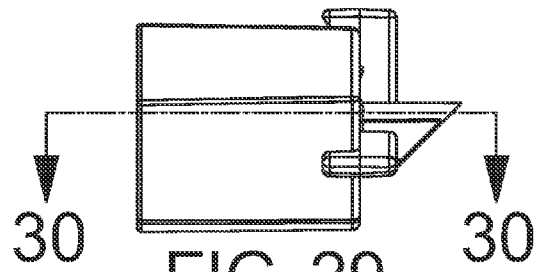

FIG. 29

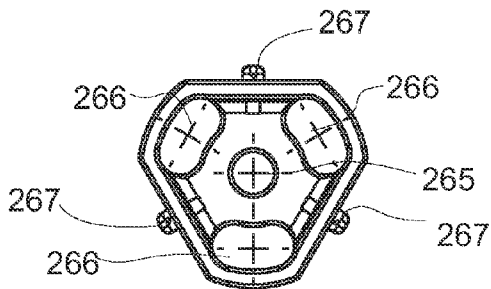

FIG. 28

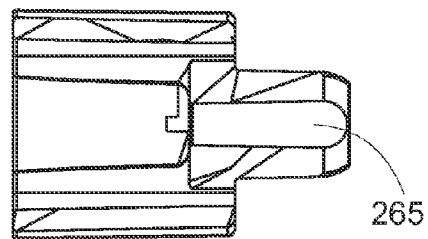

FIG. 30

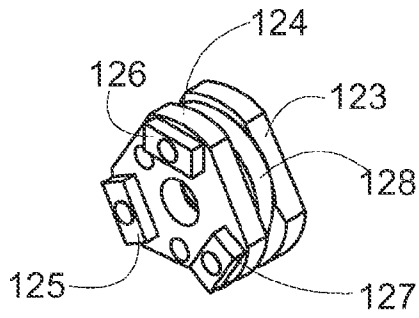

FIG. 31

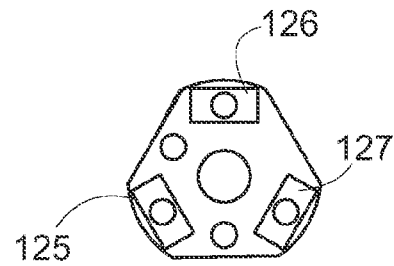

FIG. 32

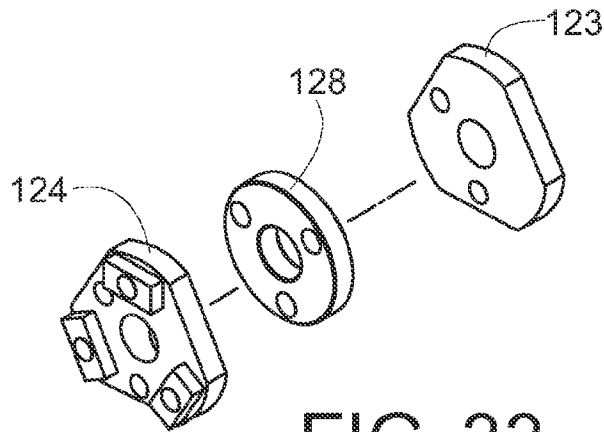

FIG. 33

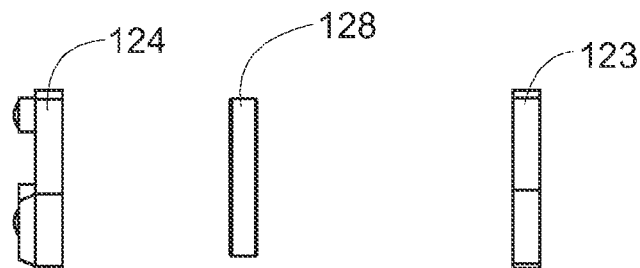

FIG. 34

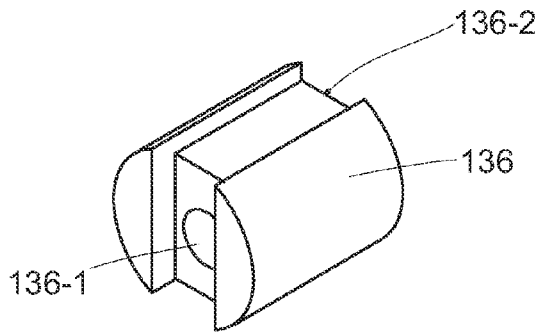

FIG. 35

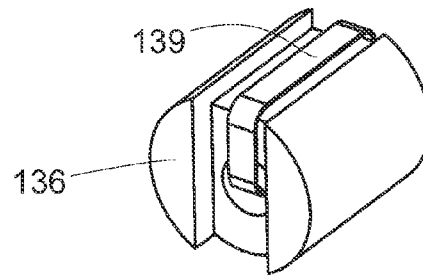

FIG. 35A

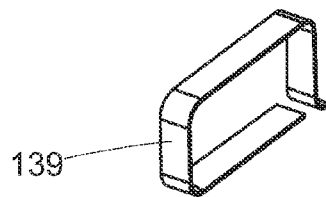

FIG. 35B

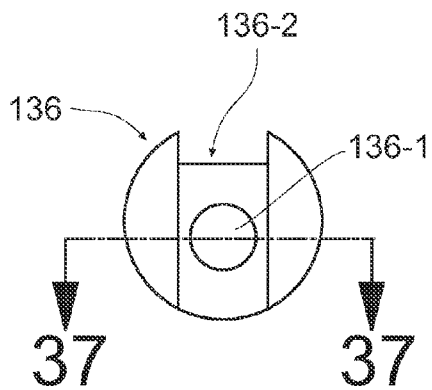

FIG. 36

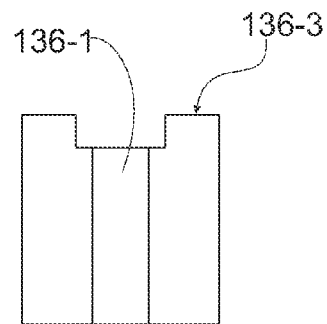

FIG. 37

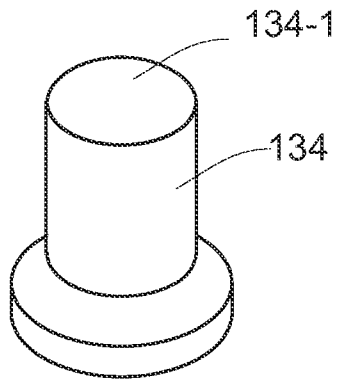

FIG. 38

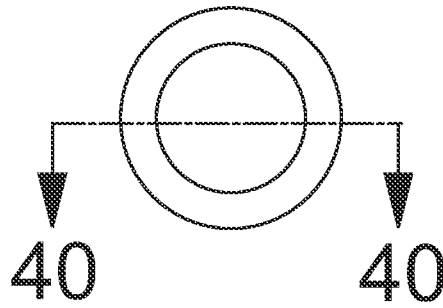

FIG. 39

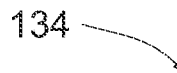

FIG. 40

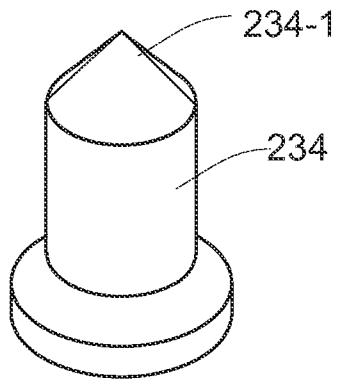

FIG. 41

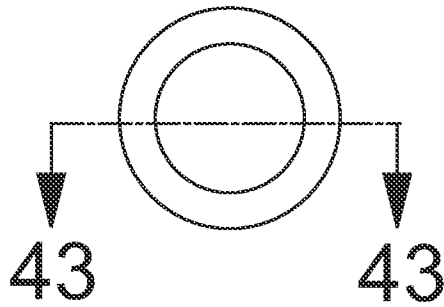

FIG. 42

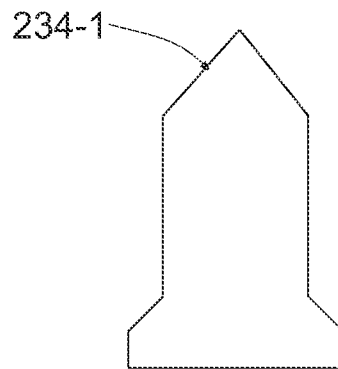
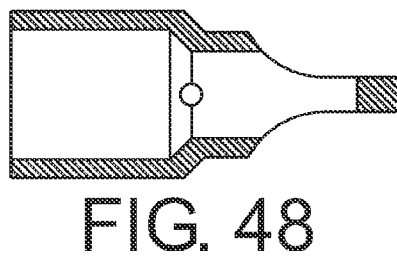
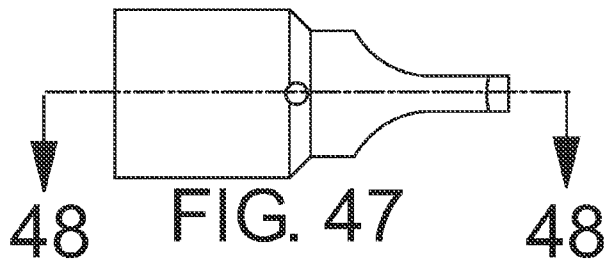
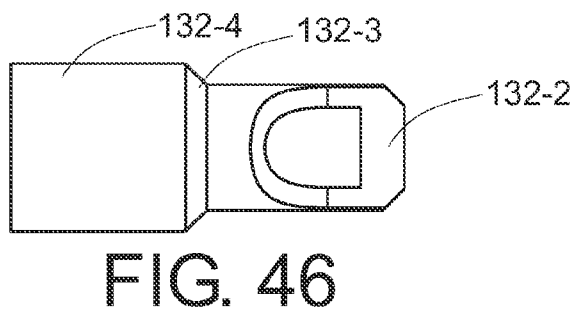
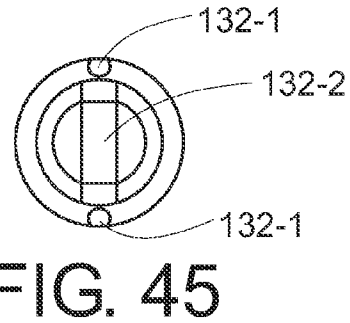
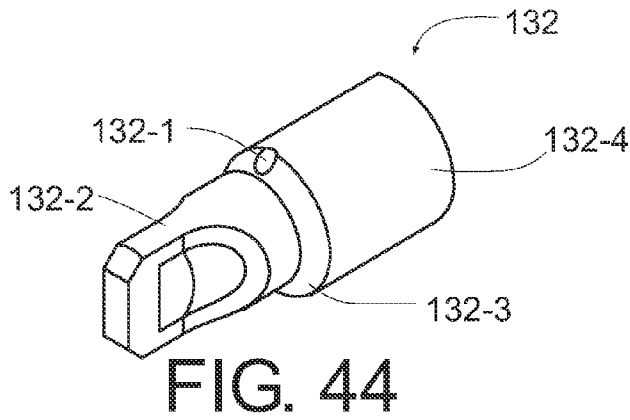

FIG. 43



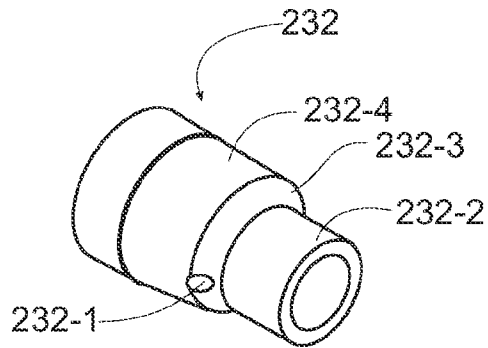

FIG. 49

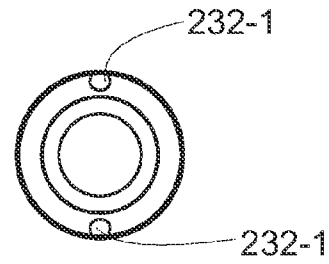

FIG. 50

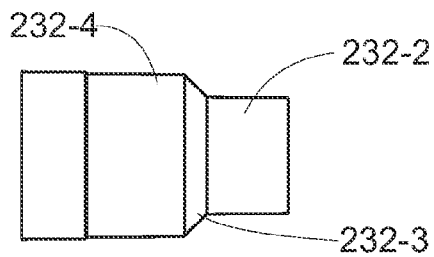

FIG. 51

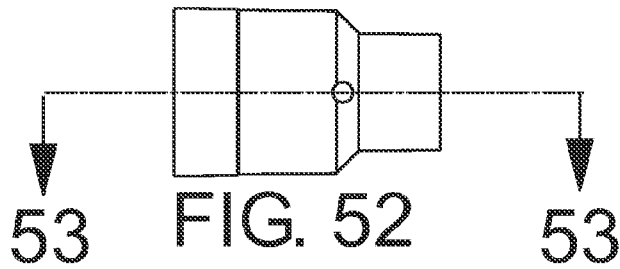

FIG. 52

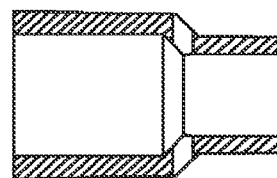

FIG. 53

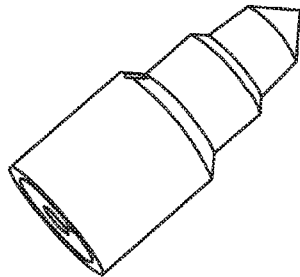

FIG. 54

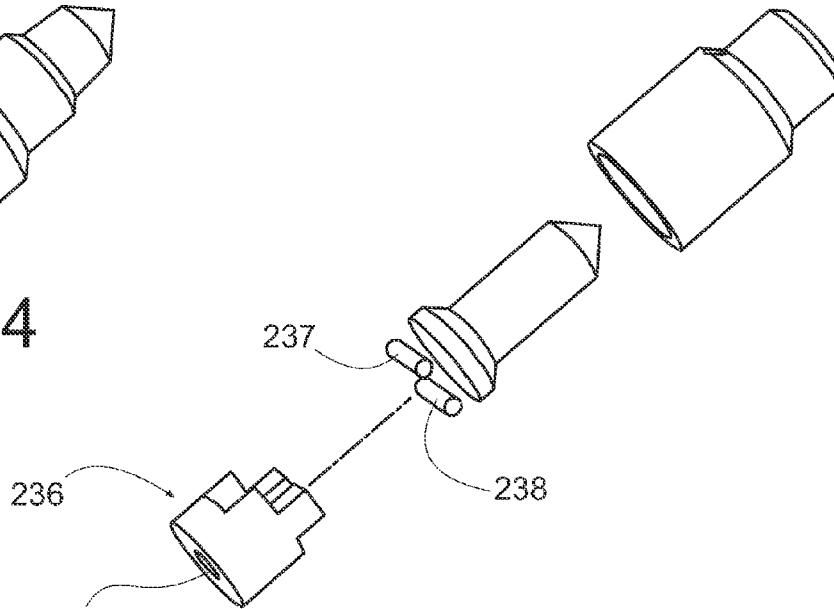

FIG. 55

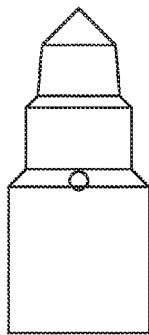

FIG. 56

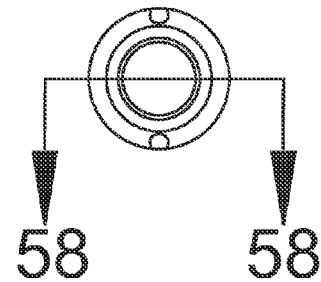

FIG. 57

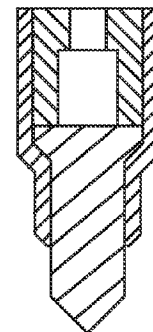

FIG. 58

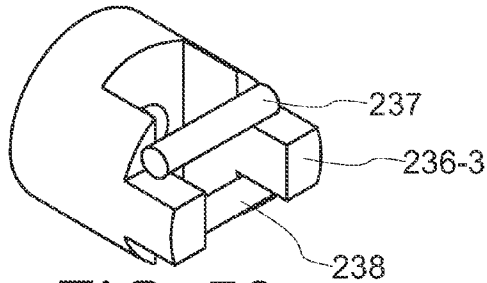

FIG. 59

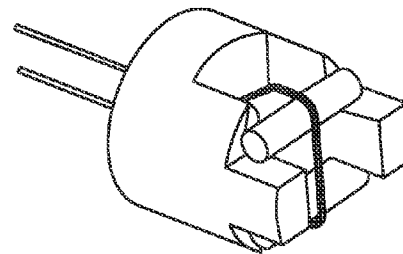

FIG. 59A

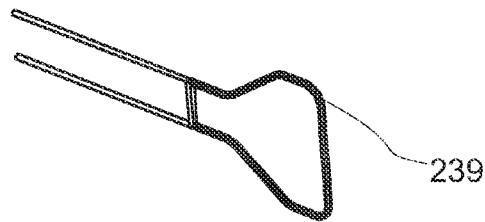

FIG. 59B

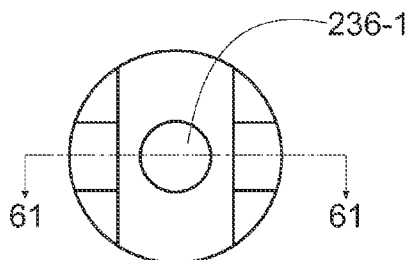

FIG. 60

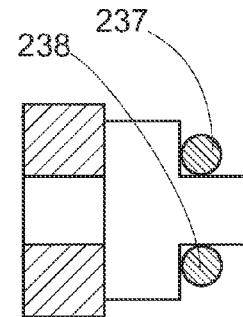

FIG. 61

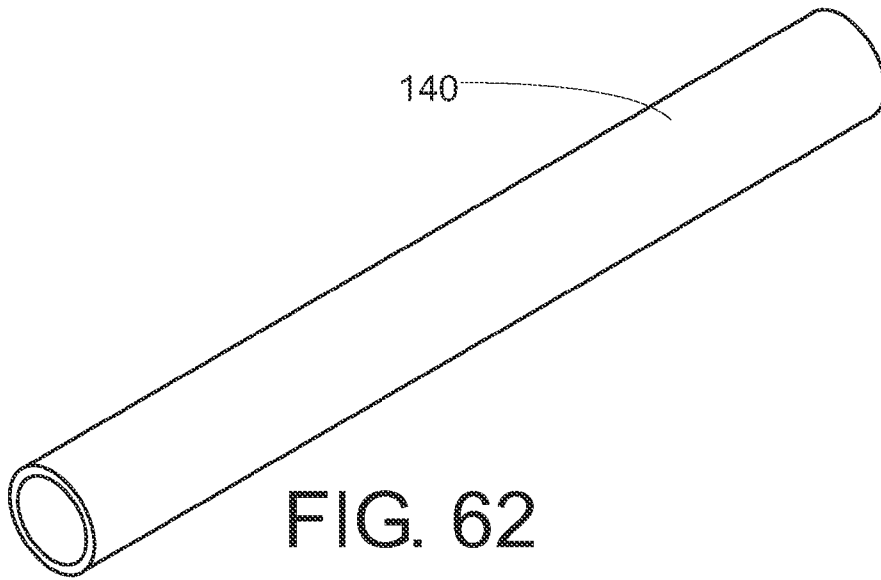

FIG. 62

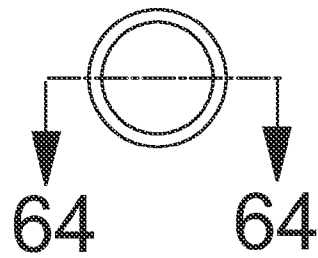
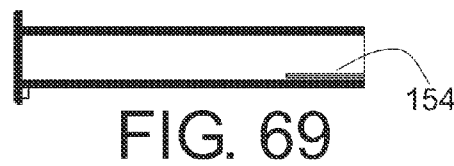
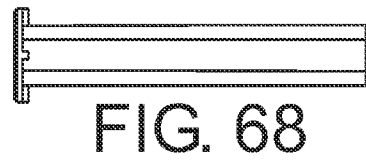
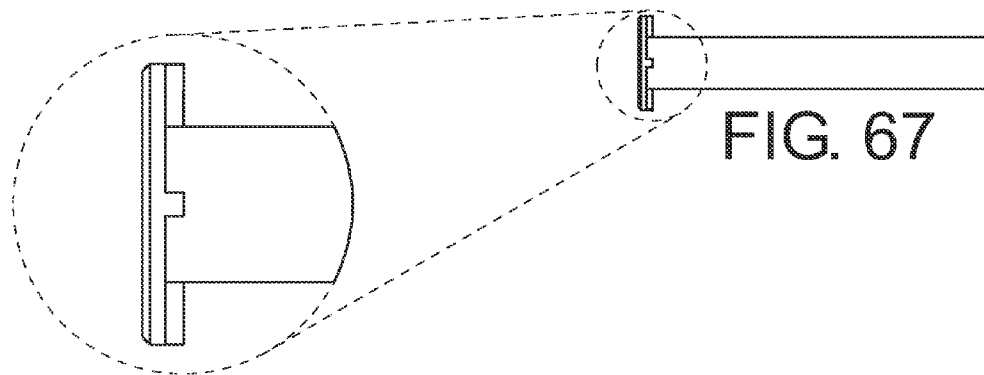
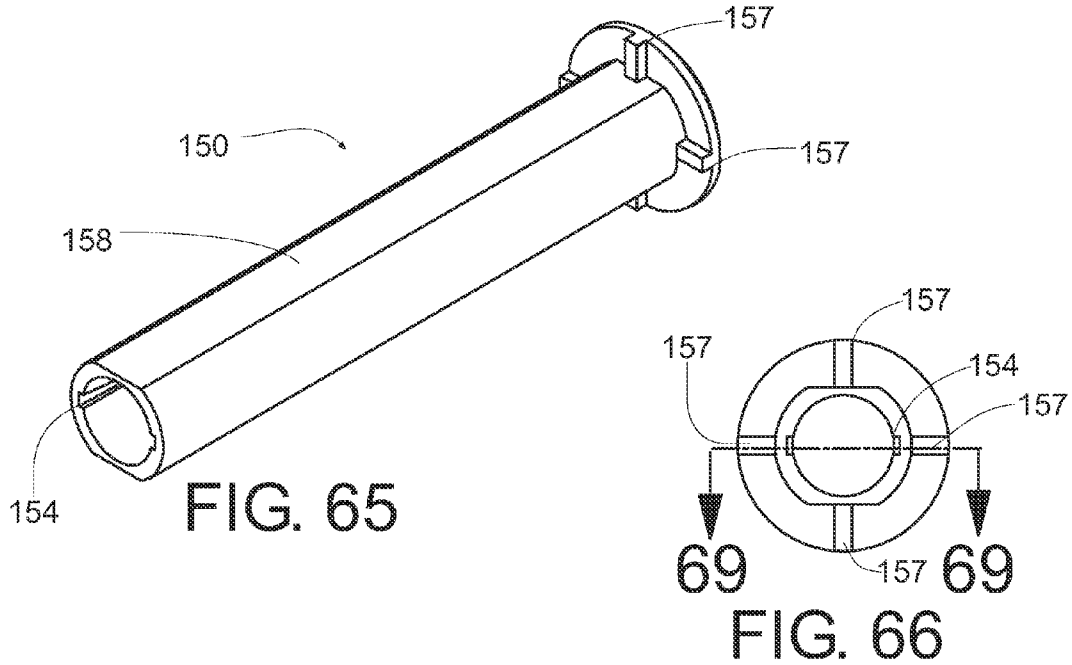

FIG. 63



FIG. 64



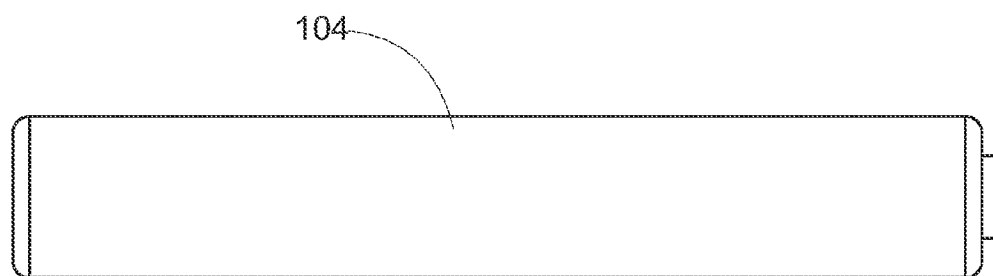

FIG. 70

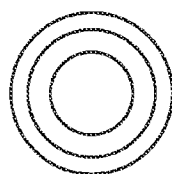

FIG. 71

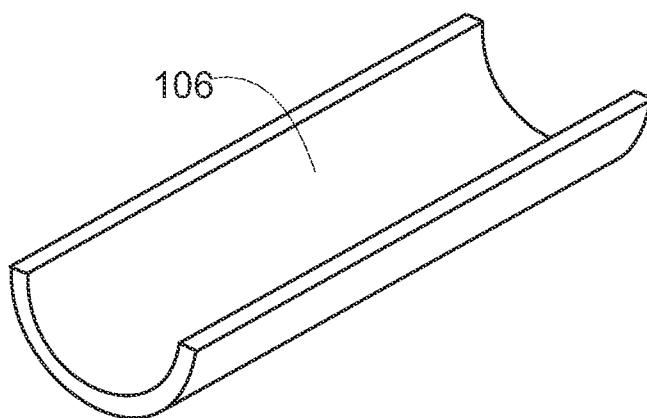

FIG. 72

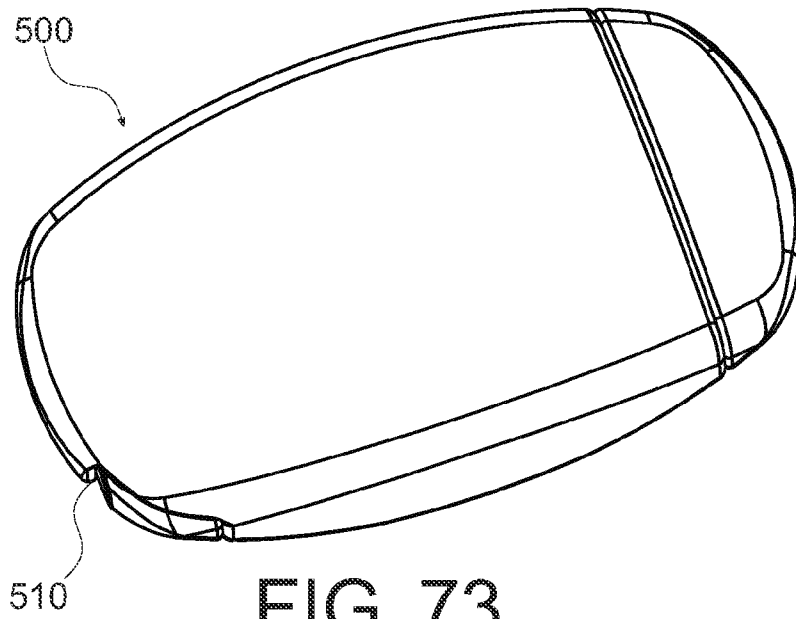

FIG. 73

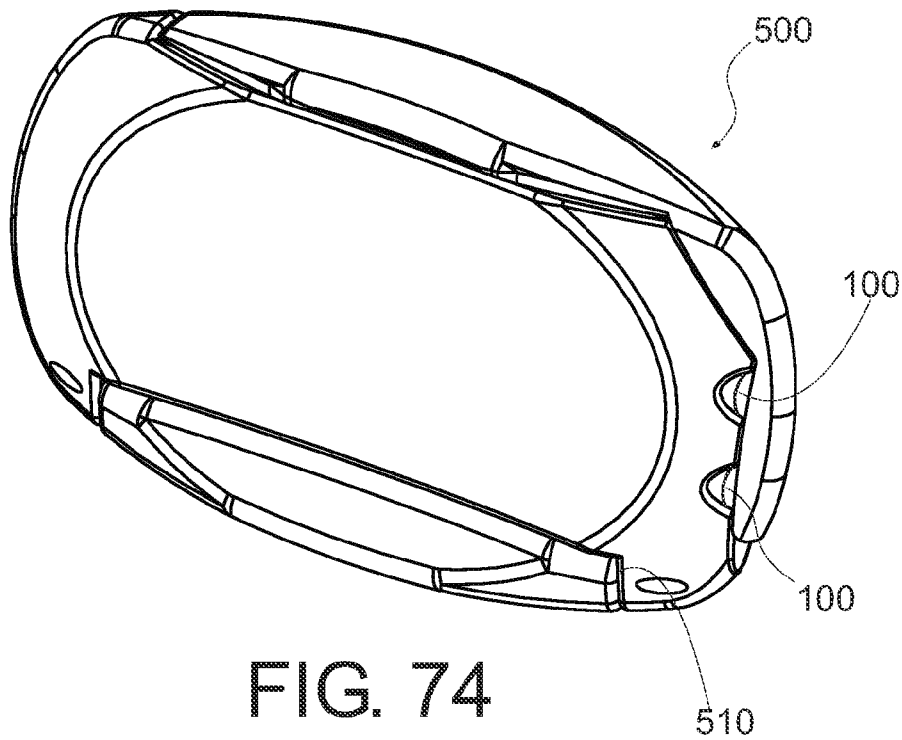

FIG. 74

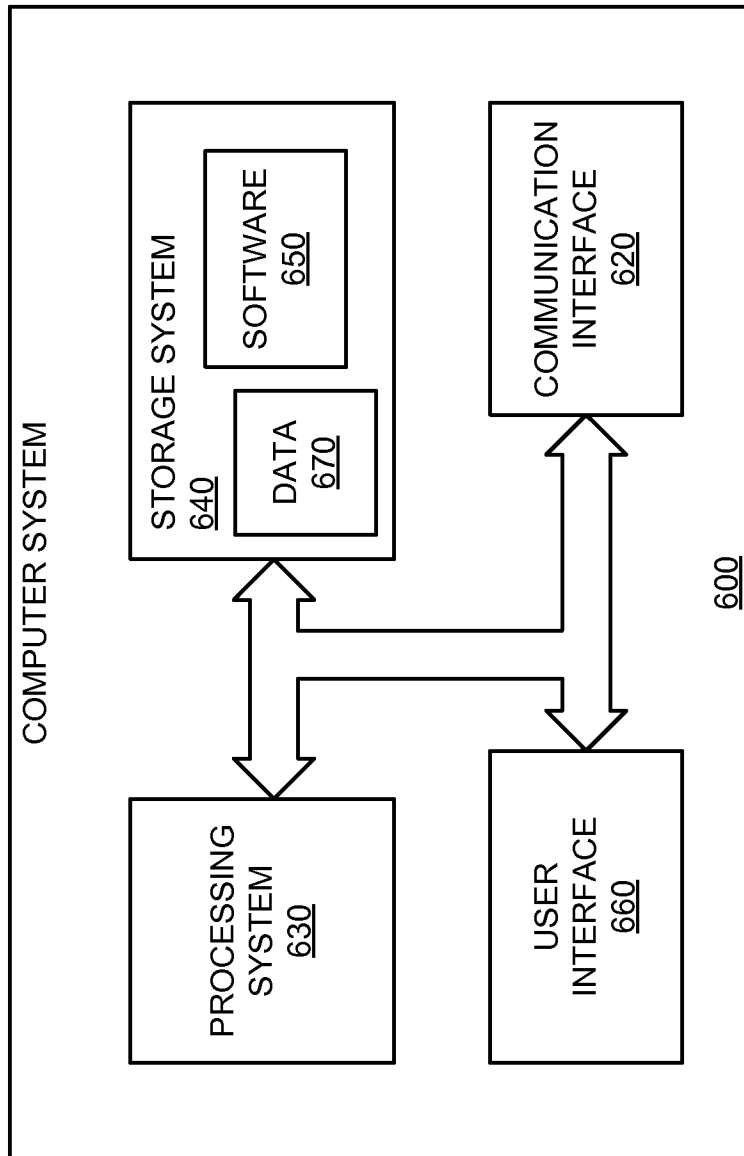

FIGURE 75

1

DISTAL END INSERTED PERSONAL VAPORIZING INHALER CARTRIDGE**CROSS-REFERENCE TO RELATED APPLICATIONS**

This application is a continuation of U.S. patent application Ser. No. 12/780,873, entitled "PERSONAL VAPORIZING INHALER CARTRIDGE", which is hereby incorporated herein by reference for all purposes. This application is related to the following U.S. applications filed on May 15, 2010: Ser. No. 12/780,871, entitled "PERSONAL VAPORIZING INHALER WITH MOUTHPIECE COVER", Ser. No. 12/780,872, entitled "ACTIVATION TRIGGER FOR A PERSONAL VAPORIZING INHALER", Ser. No. 12/780,874, entitled "ATOMIZER-VAPORIZER FOR A PERSONAL VAPORIZING INHALER", now U.S. Pat. No. 8,550,068; Ser. No. 12/780,875, entitled "PERSONAL VAPORIZING INHALER WITH INTERNAL LIGHT SOURCE", Ser. No. 12/780,876, entitled "DATA LOGGING PERSONAL VAPORIZING INHALER", and, Ser. No. 12/780,877, entitled "PERSONAL VAPORIZING INHALER ACTIVE CASE", now U.S. Pat. No. 8,314,591; whose applications are hereby incorporated herein by reference for all purposes.

TECHNICAL FIELD

This invention relates to personal vapor inhaling units and more particularly to a cartridge for an electronic flameless vapor inhaler unit that may simulate a cigarette or deliver nicotine and other medications to the oral mucosa, pharyngeal mucosa, tracheal, and pulmonary membranes.

BACKGROUND

An alternative to smoked tobacco products, such as cigarettes, cigars, or pipes is a personal vaporizer. Inhaled doses of heated and atomized flavor provide a physical sensation similar to smoking. However, because a personal vaporizer is typically electrically powered, no tobacco, smoke, or combustion is usually involved in its operation. For portability, and to simulate the physical characteristics of a cigarette, cigar, or pipe, a personal vaporizer may be battery powered. In addition, a personal vaporizer may be loaded with a nicotine bearing substance and/or a medication bearing substance. The personal vaporizer may provide an inhaled dose of nicotine and/or medication by way of the heated and atomized substance. Thus, personal vaporizers may also be known as electronic cigarettes, or e-cigarettes. Personal vaporizers may be used to administer flavors, medicines, drugs, or substances that are vaporized and then inhaled.

BRIEF DESCRIPTION OF THE DRAWINGS

FIG. 1 is a perspective view of a personal vaporizer unit.
 FIG. 2 is a side view of a personal vaporizer unit.
 FIG. 3 is an end view of the proximal end of a personal vaporizer unit.
 FIG. 4 is an end view of the distal end of a personal vaporizer unit.
 FIG. 4A is an end view of the distal end of a personal vaporizer unit having an embossed cartridge.
 FIG. 5 is a figure map of FIGS. 6 and 7.
 FIG. 6 is a cross-section of the proximal portion of a personal vaporizer unit along the cut line shown in FIG. 2.

2

FIG. 7 is a cross-section of the distal portion of a personal vaporizer unit along the cut line shown in FIG. 2.

FIG. 8 is an exploded side view of components of a personal vaporizer unit.

5 FIG. 9 is an exploded cross-section of components of a personal vaporizer unit along the cut line shown in FIG. 2.

FIG. 10 is a perspective view of a mouthpiece cover of a personal vaporizer unit.

10 FIG. 11 is a distal end view of the mouthpiece cover of FIG. 10.

FIG. 12 is a cross-section of the mouthpiece cover along the cut line shown in FIG. 11.

FIG. 13 is a perspective view of a mouthpiece of a personal vaporizer unit.

15 FIG. 14 is a side view of the mouthpiece of FIG. 13.

FIG. 15 is a cross-section of the mouthpiece along the cut line shown in FIG. 14.

20 FIG. 16 is a perspective view of a mouthpiece insulator of a personal vaporizer unit.

FIG. 17 is a distal end view of the mouthpiece insulator of FIG. 16.

25 FIG. 18 is a side view of the mouthpiece insulator of FIG. 16.

FIG. 19 is a cross-section of the mouthpiece insulator along the cut line shown in FIG. 18.

FIG. 20 is a perspective view of a main housing of a personal vaporizer unit.

30 FIG. 21 is a distal end view of the main housing of FIG. 20.

FIG. 22 is a proximal end view of the main housing of FIG. 20.

FIG. 23 is a side view of the main housing of FIG. 20.

35 FIG. 24 is a cross-section of the main housing along the cut line shown in FIG. 23.

FIG. 25 is a perspective view of a main housing of a personal vaporizer unit.

FIG. 26 is a second perspective view of the main housing of FIG. 25.

40 FIG. 27 is a distal end view of the main housing of FIG. 25.

FIG. 28 is a proximal end view of the main housing of FIG. 25.

FIG. 29 is a side view of the main housing of FIG. 25.

45 FIG. 30 is a cross-section of the main housing along the cut line shown in FIG. 29.

FIG. 31 is a perspective view of a printed circuit board (PCB or PC-board) assembly of a personal vaporizer unit.

50 FIG. 32 is a distal end view of the PCB assembly of FIG. 31.

FIG. 33 is a perspective exploded view of the PCB assembly of FIG. 31.

FIG. 34 is a side exploded view of the PCB assembly of FIG. 31.

55 FIG. 35 is a perspective view of a proximal wick element of a personal vaporizer unit.

FIG. 35A is a perspective view of a heating element disposed through a proximal wick element of a personal vaporizer unit.

60 FIG. 35B is a perspective view of a heating element of a personal vaporizer unit.

FIG. 36 is a distal end view of the wick element of FIG. 35.

65 FIG. 37 is a cross-section of the wick element along the cut line shown in FIG. 35.

FIG. 38 is a perspective view of a distal wick element of a personal vaporizer unit.

FIG. 39 is a distal end view of the wick element of FIG. 38.

FIG. 40 is a cross-section of the wick element along the cut line shown in FIG. 39.

FIG. 41 is a perspective view of a distal wick element of a personal vaporizer unit.

FIG. 42 is a distal end view of the wick element of FIG. 41.

FIG. 43 is a cross-section of the wick element along the cut line shown in FIG. 42.

FIG. 44 is a perspective view of an atomizer housing of a personal vaporizer unit.

FIG. 45 is a distal end view of the atomizer housing of FIG. 44.

FIG. 46 is a side view of the atomizer housing of FIG. 44.

FIG. 47 is a top view of the atomizer housing of FIG. 44.

FIG. 48 is a cross-section of the atomizer housing along the cut line shown in FIG. 47.

FIG. 49 is a perspective view of an atomizer housing of a personal vaporizer unit.

FIG. 50 is a distal end view of the atomizer housing of FIG. 49.

FIG. 51 is a side view of the atomizer housing of FIG. 49.

FIG. 52 is a top view of the atomizer housing of FIG. 49.

FIG. 53 is a cross-section of the atomizer housing along the cut line shown in FIG. 52.

FIG. 54 is a perspective view of an atomizer housing and wicks of a personal vaporizer unit.

FIG. 55 is an exploded view of the atomizer housing, wire guides, and wicks of FIG. 54.

FIG. 56 is a side view of the atomizer housing and wicks of FIG. 54.

FIG. 57 is a distal end view of the atomizer housing and wicks of FIG. 54.

FIG. 58 is a cross-section of the atomizer housing and wicks along the cut line shown in FIG. 57.

FIG. 59 is a perspective view of the proximal end wick and wire guides of FIGS. 54-58.

FIG. 59A is a perspective view showing a heating element disposed through the proximal end wick and around the wire guides of FIGS. 54-58.

FIG. 59B is a perspective view of the heating element of a personal vaporizer unit.

FIG. 60 is a distal end view of the wick element of FIGS. 54-58.

FIG. 61 is a cross-section of the wick element and wire guides along the cut line shown in FIG. 60.

FIG. 62 is a perspective view of a light pipe sleeve of a personal vaporizer unit.

FIG. 63 is an end view of the light pipe sleeve of FIG. 62.

FIG. 64 is a cross-section of the light pipe sleeve along the cut line shown in FIG. 63.

FIG. 65 is a perspective view of a cartridge of a personal vaporizer unit.

FIG. 66 is a proximal end view of the cartridge of FIG. 65.

FIG. 67 is a side view of the cartridge of FIG. 65.

FIG. 68 is a top view of the cartridge of FIG. 65.

FIG. 69 is a cross-section of the cartridge along the cut line shown in FIG. 66.

FIG. 70 is a side view of a battery of a personal vaporizer unit.

FIG. 71 is an end view of the battery of FIG. 70.

FIG. 72 is a perspective view of a battery support of a personal vaporizer unit.

FIG. 73 is a perspective view of a personal vaporizer unit case.

FIG. 74 is a perspective view of a personal vaporizer unit case.

FIG. 75 is a block diagram of a computer system.

DETAILED DESCRIPTION

In an embodiment a personal vaporizer unit comprises a mouthpiece configured for contact with the mouth of a person. At least part of this mouthpiece has an antimicrobial surface. This mouthpiece may also comprise silicone rubber, thermoplastic elastomer, organosilane, silver impregnated polymer, silver impregnated thermoplastic elastomer, and/or polymer. The mouthpiece may be removed from the personal vaporizer for washing or replacement, without using a tool. The mouthpiece may be provided in different colors. Designs or other patterns may be visible on the outside of the mouthpiece.

In an embodiment, a personal vaporizer unit comprises a first conductive surface configured to contact a first body part of a person holding the personal vaporizer unit, and a second conductive surface, conductively isolated from the first conductive surface, configured to contact a second body part of the person. When the personal vaporizer unit detects a change in conductivity between the first conductive surface and the second conductive surface, a vaporizer is activated to vaporize a substance so that the vapors may be inhaled by the person holding unit. The first body part and the second body part may be a lip or parts of a hand(s). The two conductive surfaces may also be used to charge a battery contained in the personal vaporizer unit. The two conductive surfaces may also form, or be part of, a connector that may be used to output data stored in a memory.

In an embodiment, a personal vaporizer unit comprises a chamber configured to receive a cartridge. The cartridge may hold a substance to be vaporized. The chamber may be configured at the distal end of the personal vaporizer unit. A user may inhale the vaporized substance at the proximal end of the personal vaporizer unit. At least one space between the exterior surface of the cartridge, and an interior surface of the chamber, may define a passage for air to be drawn from outside the personal vaporizer unit, near the distal end, through the personal vaporizer unit to be inhaled by the user along with the vaporized substance. The personal vaporizer unit may also include a puncturing element that breaks a seal on the cartridge to allow a substance in the cartridge to be vaporized. An end surface of the cartridge may be translucent to diffuse light produced internally to the personal vaporizer unit. The translucent end may be etched or embossed with letters, symbols, or other indicia that are illuminated by the light produced internally to the personal vaporizer unit.

In an embodiment, a personal vaporizer unit comprises a first wick element and a second wick element having a porous ceramic. The first wick element is adapted to directly contact a liquid held in a reservoir. The reservoir may be contained by a cartridge that is removable from the personal vaporizer unit. A heating element is disposed through the second wick element. An air gap is defined between the first wick element and the second wick element with the heating element exposed to the air gap. Air enters the first wick element through a hole in a housing holding the first wick element.

In an embodiment, a personal vaporizer unit comprises a light source internal to an opaque cylindrical housing that approximates the appearance of a smoking article. A cylindrical light tube is disposed inside the opaque cylindrical housing to conduct light emitted by the light source to an end

5

of the opaque cylindrical housing. This allows the light to be visible outside of the opaque cylindrical housing of the vaporizer.

In an embodiment, a personal vaporizer unit comprises a microprocessor, memory, and a connector. The connector outputs data stored in the memory. The microprocessor may gather, and store in the memory, information including, but not limited to, the number of cycles the device has been triggered, the duration of the cycles, the number cartridges of fluid that are delivered. The microprocessor may also gather and store times and dates associated with the other information gathered and stored. The microprocessor may detect an empty cartridge by detecting a specific change in resistance between a wick and a housing that is equivalent to a “dry wick”, and thus signifies an empty cartridge.

In an embodiment, a case comprises a cradle adapted to hold a personal vaporizer unit. The personal vaporizer unit has dimensions approximating a smoking article. The case includes a battery and at least two contacts. The two contacts may form an electrical contact with the personal vaporizer unit when the personal vaporizer unit is in the cradle. The two contacts may conduct charge from the battery to the personal vaporizer unit to charge the personal vaporizer unit. The case may also download and store data retrieved from the personal vaporizing unit. The case may download and store this data via the at least two contacts. The case may send this data to a computer via wired or wireless links. The case may have more than one cradle and sets of contacts (e.g., two sets of two contacts in order to hold and charge two personal vaporizer units).

FIG. 1 is a perspective view of a personal vaporizer unit. In FIG. 1, personal vaporizer unit 100 comprises outer main shell 102, mouthpiece cover 114, mouthpiece 116, and mouthpiece insulator 112. The mouthpiece 116 and mouthpiece cover 114 define the proximal end of personal vaporizer unit 100. The opposite end of personal vaporizer unit 100 will be referred to as the distal end. A cartridge 150 may be inserted into the distal end of personal vaporizer unit 100. Cartridge 150 may hold the substance to be vaporized by personal vaporizer unit 100. The substance after vaporizing may be inhaled by a user holding the personal vaporizer unit 100. The substance may be in the form of a liquid or gel.

FIG. 2 is a side view of a personal vaporizer unit. FIG. 2 illustrates personal vaporizer unit 100 as viewed from the side. FIG. 2 illustrates personal vaporizer unit 100 comprising outer main shell 102, mouthpiece cover 114, mouthpiece 116, and mouthpiece insulator 112. FIG. 2 also illustrates cartridge 150 inserted into the distal end of personal vaporizer unit 100.

FIG. 3 is an end view of the proximal end of a personal vaporizer unit. FIG. 3 shows the proximal end view of personal vaporizer unit 100 comprising mouthpiece cover 114. FIG. 4 is an end view of the distal end of a personal vaporizer unit. FIG. 4 shows the distal end view personal vaporizer unit 100 comprising the visible portion of cartridge 150. FIG. 4A is an alternative end view of personal vaporizer unit 100 comprising a visible portion of cartridge 150 that has visible logos, letters, or other symbols. These visible logos, letters, or other symbols may be illuminated or backlit by a light source internal to the personal vaporizer unit 100. The light source may be activated intermittently under the control of a microprocessor or other electronics internal to personal vaporizer unit 100. The light source may be activated in such a manner as to simulate the glowing ash of a cigar or cigarette.

FIG. 5 is a figure map of FIGS. 6 and 7. FIG. 6 is a cross-section of the proximal portion of a personal vaporizer

6

unit along the cut line shown in FIG. 2. In FIG. 6, the proximal portion of personal vaporizer unit 100 comprises mouthpiece cover 114, mouthpiece 116, mouthpiece insulator 112, outer main shell 102, battery support 106, and battery 104. The mouthpiece cover 114 surrounds and is engaged with the distal end of mouthpiece 116. Mouthpiece 116 and outer main shell 102 are preferably made of an electrically conductive material(s). Mouthpiece 116 is separated from outer main shell 102 by mouthpiece insulator 112. Mouthpiece 116 and outer main shell 102 are thus electrically isolated from each other by mouthpiece insulator 112.

In an embodiment, personal vaporizer unit 100 is configured such that outer main shell 102 comprises a first conductive surface configured to contact a first body part of a person holding personal vaporizer unit 100. Mouthpiece 116 comprises a second conductive surface, which is conductively isolated from the first conductive surface. This second conductive surface is configured to contact a second body part of the person. When personal vaporizer unit 100 detects a change in conductivity between the first conductive surface and the second conductive surface, a vaporizer internal to personal vaporizer unit 100 is activated to vaporize a substance in cartridge 150 so that the vapors may be inhaled by the person holding personal vaporizer unit 100. The first body part and the second body part may be a lip or parts of a hand(s). The two conductive surfaces of outer main shell 102 and mouthpiece 116, respectively, may also be used to charge battery 104 contained in the personal vaporizer unit 100. The two conductive surfaces of outer main shell 102 and mouthpiece 116, respectively, may also be used to output (or input) data stored (or to be stored) in a memory (not shown).

Battery support 106 functions to hold battery 104 in a position which is fixed relative to our main shell 102. Battery support 106 is also configured to allow air and vaporized substance to pass from the distal end of personal vaporizer unit 100 past battery 104 along one or more passageways. After air and the vapors of the vaporized substance pass by battery 104, they may pass through openings in mouthpiece 116, mouthpiece cover 114, and mouthpiece insulator 112, to be inhaled by a user.

FIG. 7 is a cross-section of the distal portion of a personal vaporizer unit along the cut line shown in FIG. 2. In FIG. 7, the distal end portion of personal vaporizer unit 100 comprises outer main shell 102, light pipe sleeve 140, and atomizer housing 132, distal wick 134, proximal wick 136, PC board 123, PC board 124, spacer 128, and main housing 160. FIG. 7 also illustrates cartridge 150 inserted into the distal end of personal vaporizer unit 100. As can be seen in FIG. 7, cartridge 150 may hold a substance (e.g., a liquid or gel) in direct contact with distal wick 134. The substance may be drawn through distal wick 134 to be vaporized inside atomizer assembly. The atomizer assembly comprises atomizer housing 132, distal wick 134, proximal wick 136, and a heating element (not shown).

FIG. 8 is an exploded side view of components of a personal vaporizer unit. FIG. 9 is an exploded cross-section of components of a personal vaporizer unit along the cut line shown in FIG. 2.

In FIGS. 8 and 9, personal vaporizer unit 100 comprises (from left to right) mouthpiece cover 114, mouthpiece 116, mouthpiece insulator 112, battery 104, battery support 106, PC board 123, spacer 128, PC board 124, main housing 160, proximal wick 136, distal wick 134, atomizer housing 132, light pipe sleeve 140, and cartridge 150. Mouthpiece cover 114 surrounds and covers the proximal end of mouthpiece

116. The distal end of mouthpiece 116 is inserted into mouthpiece insulator 112. Battery 104 is held in place by battery support 106. PC board 123, spacer 128 and PC board 124 are disposed within main housing 160. Proximal wick 136 and distal wick 134 are disposed within atomizer housing 132.

Atomizer housing 132 (and therefore proximal wick 136, distal wick 134) are disposed inside light pipe sleeve 140 and main shell 102. (Note: for clarity, main shell 102 is not shown in FIGS. 8 and 9.) Light pipe sleeve 140 is disposed within main shell 102. Light pipe sleeve 140 is positioned such that light emitted from a light source mounted on PC board 124 may be conducted via light pipe sleeve 140 to a location where it is visible on the outside of personal vaporizer unit 100.

Cartridge 150 is disposed within light pipe sleeve 140. When assembled, a substance contained within cartridge 150 is held in direct contact with distal wick 134. When cartridge 150 is inserted into personal vaporizer unit 100 atomizer housing 132 or distal wick 134 may puncture a seal or cap that contains the substance to be vaporized within cartridge 150. Once punctured, the substance held within a reservoir of cartridge 150 may come in direct contact with distal wick 134.

FIG. 10 is a perspective view of a mouthpiece cover of a personal vaporizer unit. FIG. 11 is a distal end view of the mouthpiece cover of FIG. 10. FIG. 12 is a cross-section of the mouthpiece cover along the cut line shown in FIG. 11. As can be seen in FIGS. 10-12, mouthpiece cover 114 has an opening 114-1 that allows air and the vaporized substance to be drawn through mouthpiece cover 114. Mouthpiece cover 114 is configured for contact with the mouth of a person. In an embodiment, at least part of the mouthpiece cover has an antimicrobial surface. This antimicrobial surface of mouthpiece cover 114 may comprise, but is not limited to: silicone rubber, thermoplastic elastomer, organosilane, silver impregnated polymer, silver impregnated thermoplastic elastomer, and/or polymer. Mouthpiece cover 114 is also configured to be removable from personal vaporizer unit 100 by a user without the use of tools. This allows mouthpiece cover 114 to be replaced and/or washed. In an embodiment, mouthpiece cover 114 may be held in place on personal vaporizer unit 100 by annular ridge 114-2 which interfaces with a groove on mouthpiece 116 of personal vaporizer unit 100 to secure mouthpiece cover 114 in place. In another embodiment, mouthpiece cover 114 may be held in place on personal vaporizer unit 100 by a friction fit.

FIG. 13 is a perspective view of a mouthpiece of a personal vaporizer unit. FIG. 14 is a side view of the mouthpiece of FIG. 13. FIG. 15 is a cross-section of the mouthpiece along the cut line shown in FIG. 14. As can be seen in FIGS. 13-15, mouthpiece 116 has a passageway 116-1 that allows air and the vaporized substance to be drawn through mouthpiece 116. Mouthpiece 116 may comprise a conductive surface or material configured to contact a first body part of a person holding personal vaporizer unit 100. This first body part may be part of a hand, or at least one lip of the person holding personal vaporizer unit 100. In an embodiment, mouthpiece 116 has an annular groove 116-2 around an outside surface. This groove is configured to receive annular ridge 114-2. Thus, annular groove 116-2 helps secure mouthpiece cover 114 to personal vaporizer unit 100.

FIG. 16 is a perspective view of a mouthpiece insulator of a personal vaporizer unit. FIG. 17 is a distal end view of the mouthpiece insulator of FIG. 16. FIG. 18 is a side view of the mouthpiece insulator of FIG. 16. FIG. 19 is a cross-

section of the mouthpiece insulator along the cut line shown in FIG. 18. As discussed previously, mouthpiece insulator 112 is disposed between main shell 102 and mouthpiece 116. As can be seen in FIGS. 16-18, mouthpiece insulator 112 has a passageway 112-1 that allows air and the vaporized substance to be drawn through mouthpiece insulator 112. Because mouthpiece insulator 112 is disposed between main shell 102 and mouthpiece 116, mouthpiece insulator 112 can electrically isolate main shell 102 and mouthpiece 116. Thus, in an embodiment, mouthpiece insulator 112 comprises, or is made of, a non-electrically conductive material. This electrical isolation between main shell 102 and mouthpiece 116 allow electrical impedance changes between main shell 102 and mouthpiece 116 to be detected.

For example, a first conductive surface on mouthpiece 116 may be configured to contact a first body part of a person holding personal vaporizer unit 100. A second conductive surface on main shell 102 (which is conductively isolated from said first conductive surface by mouthpiece insulator 112) may be configured to contact a second body part of the person. Personal vaporizer unit 100 may then activate in response to detecting a change in conductivity between the first conductive surface and the second conductive surface. In an embodiment, this change in conductivity may comprise a drop in impedance between the first conductive surface and the second conductive surface. In an embodiment, the change in conductivity may comprise a change in capacitance between the first conductive surface and the second conductive surface. The first body part may be a finger. The second body part may be a lip. The second body part may be a second finger. In an embodiment, the first conductive surface and the second conductive surfaces may be used to pass a charging current to battery 104. The first and second conductive surfaces may also be used to transfer data to or from personal vaporizer unit 100.

FIG. 20 is a perspective view of a main housing of a personal vaporizer unit. FIG. 21 is a distal end view of the main housing of FIG. 20. FIG. 22 is a proximal end view of the main housing of FIG. 20. FIG. 23 is a side view of the main housing of FIG. 20. FIG. 24 is a cross-section of the main housing along the cut line shown in FIG. 23. Main housing 160 is configured to hold PC-boards 123 and 124, and spacer 128. Main housing 160 is configured to fit within main shell 102 via a friction fit. Main housing 160 has several holes 166 that allow light generated by a light source(s) on PC-board 124 to pass. Once this light passes through holes 166, it may be coupled into light pipe sleeve 140 where it is conducted to a visible location on the outside of personal vaporizer unit 100.

Main housing 160 also has a hole 165 that allows an electrical conductor (not shown) to run from PC-board 123 or PC-board 124 through main housing 160. This electrical conductor may be, or connect to, a heating element (not shown). This heating element may help vaporize the substance to be inhaled by the user of personal vaporizer unit 100. This heating element may be controlled by circuitry on PC-board 123 or PC-board 124. This heating element may be activated in response to a change in conductivity between the first conductive surface and the second conductive surface, described previously.

The exterior of main housing 160 may also have a flat surface 164 (or other geometry) forming a galley that is configured to allow the vaporized substance and air to pass between the main housing 160 and the main shell 102. Once the vaporized substance and air pass by main housing 160, they may travel through passageway 112-1, passageway 116-1, and opening 114-1 to be inhaled by a user of personal

vaporizer unit **100**. The exterior of main housing **160** may also have one or more standoffs **167** (or other geometries) that are configured to allow air and the vaporized substance to reach the passageway formed by flat surface **164** and main shell **102**.

FIG. **25** is a perspective view of a main housing of a personal vaporizer unit. FIG. **26** is a second perspective view of the main housing of FIG. **25**. FIG. **27** is a distal end view of the main housing of FIG. **25**. FIG. **28** is a proximal end view of the main housing of FIG. **25**. FIG. **29** is a side view of the main housing of FIG. **25**. FIG. **30** is a cross-section of the main housing along the cut line shown in FIG. **29**. Main housing **260** may be used as an alternative embodiment to main housing **160**.

Main housing **260** is configured to hold PC-boards **123** and **124**, and spacer **128**. Main housing **260** is configured to fit within main shell **102** via a friction fit. Main housing **260** has several holes **266** that allow light generated by a light source(s) on PC-board **124** to pass. Once this light passes through holes **266**, it may be coupled into light pipe sleeve **140** where it is conducted to a visible location on the outside of personal vaporizer unit **100**.

Main housing **260** also has a hole **265** that allows an electrical conductor (not shown) to run from PC-board **123** or PC-board **124** through main housing **260**. This electrical conductor may be, or connect to, a heating element (not shown). This heating element may help vaporize the substance to be inhaled by the user of personal vaporizer unit **100**. This heating element may be controlled by circuitry on PC-board **123** or PC-board **124**. This heating element may be activated in response to a change in conductivity between the first conductive surface and the second conductive surface, described previously.

The exterior of main housing **260** may also have flat surfaces **264** (or other geometry) that form a galley that is configured to allow the vaporized substance and air to pass between the main housing **260** and the main shell **102**. Once the vaporized substance and air pass by main housing **260**, they may travel through passageway **112-1**, passageway **116-1**, and opening **114-1** to be inhaled by a user of personal vaporizer unit **100**. The exterior of main housing **260** may also have one or more standoffs **267** (or other geometries) that are configured to allow air and the vaporized substance to reach the passageway formed by flat surfaces **264** and main shell **102**.

FIG. **31** is a perspective view of a printed circuit board assembly of a personal vaporizer unit. FIG. **32** is a distal end view of the PCB assembly of FIG. **31**. FIG. **33** is a perspective exploded view of the PCB assembly of FIG. **31**. FIG. **34** is a side exploded view of the PCB assembly of FIG. **31**. As can be seen in FIGS. **31-34**, the PCB assembly is comprised of PC-board **123** and PC-board **124** separated by a spacer **128**. PC-board **124** may have mounted upon it light emitting diodes (LEDs) **125-127** or other light sources. LEDs **125-127** are configured and positioned such that when they produce light, that light passes through holes **166** or **266** in main housings **160** and **260**, respectively. This light may then be conducted by light pipe sleeve **140** to a location where it will be visible exterior to personal vaporizer unit **100**.

PC-board **123** may have mounted on it a microprocessor, memory, or other circuitry (not shown) to activate or otherwise control personal vaporizer unit **100**. This microprocessor may store data about the operation of personal vaporizer unit **100** in the memory. For example, the microprocessor may determine and store the number of cycles personal vaporizer unit **100** has been triggered. The micro-

processor may also store a time and/or date associated with one or more of these cycles. The microprocessor may cause this data to be output via a connector. The connector may be comprised of the first and second conductive surfaces of mouthpiece **116** and/or main shell **102**.

In an embodiment, the microprocessor may determine a duration associated with various cycles where personal vaporizer unit **100** has been triggered. These durations (or a number based on these duration, such as an average) may be stored in the memory. The microprocessor may cause these numbers to be output via the connector. The microprocessor may determine an empty cartridge condition and stores a number associated with a number of times said empty cartridge condition occurs. The microprocessor, or other circuitry, may determine an empty cartridge condition determined based on a resistance between atomizer housing **132** or **232** and a wick **134**, **234**, **136**, or **236**. The microprocessor may also store a time and/or date associated with one or more of these empty cartridge conditions. The number of times an empty cartridge condition is detected, and or times and/or dates associated with these empty cartridge conditions may be output via the connector.

Battery **104**, PC-board **123**, PC-board **124**, and all electronics internal to personal vaporizer unit **100** may be sealed in a plastic or plastic and epoxy compartment within the device. This compartment may include main housing **160** or **260**. All penetrations in this compartment may be sealed. Thus, only wires will protrude from the compartment. The compartment may be filled with epoxy after the assembly of battery **104**, PC-board **123**, PC-board **124**, and LEDs **125-127**. The compartment may be ultrasonically welded closed after assembly of battery **104**, PC-board **123**, PC-board **124**, and LEDs **125-127**. This sealed compartment is configured such that all vapor within personal vaporizer unit **100** does not come in contact with the electronics on PC-boards **123** or **124**.

FIG. **35** is a perspective view of a proximal wick element of a personal vaporizer unit. FIG. **35A** is a perspective view of a heating element disposed through a proximal wick element of a personal vaporizer unit. FIG. **35B** is a perspective view of a heating element of a personal vaporizer unit. FIG. **36** is a distal end view of the wick element of FIG. **35**. FIG. **37** is a cross-section of the wick element along the cut line shown in FIG. **35**. Proximal wick **136** is configured to fit within atomizer housing **132**. As can be seen in FIGS. **35-37**, proximal wick **136** includes internal wire passageway **136-1** and external wire passageway **136-2**. These wire passageways allows a conductor or a heating element **139** to be positioned through proximal wick **136** (via internal wire passageway **136-1**). This conductor or heating element **139** may also be positioned in external wire passageway **136-2**. Thus, as shown in FIG. **35A**, a conductor or heating element **139** may be wrapped around a portion of proximal wick **136** by running the conductor or heating element **139** through internal wire passageway **136-1**, around the distal end of proximal wick **136**, and through external wire passageway **136-2** to return to approximately its point of origin. The heating element **139** may, when personal vaporizer unit **100** is activated, heat proximal wick **136** in order to facilitate vaporization of a substance.

FIG. **38** is a perspective view of a distal wick element of a personal vaporizer unit. FIG. **39** is a distal end view of the wick element of FIG. **38**. FIG. **40** is a cross-section of the wick element along the cut line shown in FIG. **39**. Distal wick **134** is configured to fit within atomizer housing **132**. As can be seen in FIGS. **38-40**, distal wick **134** comprises two cylinders of different diameters. A chamfered surface

11

transitions from the smaller diameter of the distal end of distal wick 134 to a larger diameter at the proximal end of distal wick 134. The cylinder at the distal end terminates with a flat surface end 134-1. This flat surface end 134-1 is the end of distal wick 134 is a surface that is placed in direct contact with a substance to be vaporized when cartridge 150 is inserted into the distal end of personal vaporizer 100. The proximal end of distal wick 134 is typically in contact with proximal wick 136. However, at least a part of proximal wick 136 and distal wick 134 are separated by an air gap. When distal wick 134 and proximal wick 136 are used together, this air gap is formed between distal wick 134 and proximal wick 136 by stand offs 136-3 as shown in FIG. 37.

FIG. 41 is a perspective view of a distal wick element of a personal vaporizer unit. FIG. 42 is a distal end view of the wick element of FIG. 41. FIG. 43 is a cross-section of the wick element along the cut line shown in FIG. 42. Proximal wick 234 may be used as an alternative embodiment to distal wick 134. Proximal wick 234 is configured to fit within atomizer housing 232. As can be seen in FIGS. 41-43, proximal wick 234 comprises two cylinders of different diameters, and a cone or pointed end 234-1. A chamfered surface transitions from the smaller diameter of the distal end of proximal wick 234 to a larger diameter at the proximal end of proximal wick 234. The cylinder at the distal end terminates with a pointed end 234-1. This pointed end 234-1 is the end of proximal wick 234 that is in direct contact with a substance to be vaporized. This pointed end 234-1 may also break a seal on cartridge 150 to allow the substance to be vaporized to come in direct contact with proximal wick 234. The proximal end of proximal wick 234 is typically in contact with proximal wick 136. However, at least a part of proximal wick 136 and proximal wick 234 are separated by an air gap. When distal wick 134 and proximal wick 236 are used together, this air gap is formed between proximal wick 234 and proximal wick 136 by stand offs 136-3 as shown in FIG. 37.

FIG. 44 is a perspective view of an atomizer housing of a personal vaporizer unit. FIG. 45 is a distal end view of the atomizer housing of FIG. 44. FIG. 46 is a side view of the atomizer housing of FIG. 44. FIG. 47 is a top view of the atomizer housing of FIG. 44. FIG. 48 is a cross-section of the atomizer housing along the cut line shown in FIG. 47. Atomizer housing 132 is configured to fit within main shell 102. As can be seen in FIGS. 44-48, atomizer housing 132 comprises roughly two cylinders of different diameters. A chamfered surface 132-3 transitions from the smaller diameter of the distal end of atomizer housing 132 to a larger diameter at the proximal end of atomizer housing 132. The larger diameter at the proximal end of atomizer housing 132 is configured to be press fit into light pipe sleeve 140. The cylinder at the distal end terminates with a spade shaped tip 132-2. This spade shaped tip 132-2 may break a seal on cartridge 150 to allow the substance to be vaporized to come in direct contact with distal wick 134. Other shaped tips are possible (e.g., needle or spear shaped).

Chamfered surface 132-3 has one or more holes 132-1. These holes allow air to pass, via suction, through atomizer housing 132 into distal wick 134. This suction may be supplied by the user of personal vaporizer 100 sucking or inhaling on mouthpiece cover 114 and/or mouthpiece 116. The air that is sucked into distal wick 134 enters distal wick 134 on or near the chamfered surface between the two cylinders of distal wick 134. The air that is sucked into distal wick 134 displaces some of the substance being vaporized that has been absorbed by distal wick 134 causing it to be atomized as it exits distal wick 134 into the air gap formed

12

between distal wick 134 and proximal wick 136. The heating element disposed around proximal wick 136 may then vaporize at least some of the atomized substance. In an embodiment, one or more holes 132-1 may range in diameter between 0.02 and 0.0625 inches.

In an embodiment, placing holes 132-1 at the leading edge of the chamfered surface places a set volume of the substance to be vaporized in the path of incoming air. This incoming air has nowhere to go but through the large diameter (or "head") end of the distal end wick 134. When the air enters this area in distal end wick 134 it displaces the substance to be vaporized that is suspended in distal end wick 134 towards an air cavity between distal end wick 134 and proximal end wick 136. When the displaced substance to be vaporized reaches the surface of distal end wick 134, it is forced out of the wick by the incoming air and the negative pressure of the cavity. This produces an atomized cloud of the substance to be vaporized. In an embodiment, the diameter of the head of distal end wick 134 may be varied and be smaller than the diameter of the proximal end wick 136. This allows for a tuned volume of air to bypass proximal end wick 136 and directly enter the cavity between distal wick 134 and distal wick 136 without first passing through distal wick 136.

FIG. 49 is a perspective view of an atomizer housing of a personal vaporizer unit. FIG. 50 is a distal end view of the atomizer housing of FIG. 49. FIG. 51 is a side view of the atomizer housing of FIG. 49. FIG. 52 is a top view of the atomizer housing of FIG. 49. FIG. 53 is a cross-section of the atomizer housing along the cut line shown in FIG. 52. Atomizer housing 232 is an alternative embodiment, for use with proximal wick 234, to atomizer house 132. Atomizer housing 232 is configured to fit within main shell 102 and light pipe sleeve 140. As can be seen in FIGS. 49-53, atomizer housing 232 comprises roughly two cylinders of different diameters. A chamfered surface 232-3 transitions from the smaller diameter of the distal end of atomizer housing 232 to a larger diameter at the proximal end of atomizer housing 232. The larger diameter at the proximal end of atomizer housing 232 is configured to be press fit into light pipe sleeve 140. The cylinder at the distal end terminates with an open cylinder tip 232-2. This open cylinder tip 232-2 allows the pointed end 234-1 of proximal wick 234 to break a seal on cartridge 150 to allow the substance to be vaporized to come in direct contact with proximal wick 234.

Chamfered surface 232-3 has one or more holes 232-1. These holes allow air to pass, via suction, through atomizer housing 232 into proximal wick 234. The air that is sucked into proximal wick 234 enters proximal wick 234 on or near the chamfered surface between the two cylinders of proximal wick 234. The air that is sucked into proximal wick 234 displaces some of the substance being vaporized that has been absorbed by proximal wick 234 causing it to be atomized as it exits proximal wick 234 into the air gap formed between proximal wick 234 and proximal wick 136. The heating element disposed around proximal wick 136 may then vaporize at least some of the atomized substance being vaporized. In an embodiment, one or more holes 232-1 may range in diameter between 0.02 and 0.0625 inches.

In an embodiment, placing holes 232-1 at the leading edge of the chamfered surface places a set volume of the substance to be vaporized in the path of incoming air. This incoming air has nowhere to go but through the head of the distal end wick 234. When the air enters this area in distal end wick 234 it displaces the substance to be vaporized that is suspended in distal end wick 234 towards an air cavity

13

between distal end wick **234** and proximal end wick **236**. When the displaced substance to be vaporized reaches the surface of distal end wick **232**, it is forced out of the wick by the incoming air and the negative pressure of the cavity. This produces an atomized cloud of the substance to be vaporized. In an embodiment, the diameter of the head of distal end wick **234** may be varied and be smaller than the diameter of the proximal end wick **236**. This allows for a tuned volume of air to bypass distal wick **236** and directly enter the cavity between proximal wick **234** and distal wick **236** without first passing through distal wick **236**.

FIG. **54** is a perspective view of an atomizer housing and wicks of a personal vaporizer unit. FIG. **55** is an exploded view of the atomizer housing, wire guides, and wicks of FIG. **54**. FIG. **56** is a side view of the atomizer housing and wicks of FIG. **54**. FIG. **57** is a distal end view of the atomizer housing and wicks of FIG. **54**. FIG. **58** is a cross-section of the atomizer housing and wicks along the cut line shown in FIG. **57**. The atomizer housing and wicks shown in FIGS. **54-58** is an alternative embodiment for use with proximal wick **236**. The embodiment shown in FIGS. **54-58** use atomizer housing **232**, proximal wick **234**, proximal wick **236**, wire guide **237**, and wire guide **238**. Proximal wick **236** is configured to fit within atomizer housing **232**. As can be seen in FIGS. **54-58**, proximal wick **236** includes internal wire passageway **236-1**. This wire passageway **236-1** allows a conductor or a heating element (not shown) to be positioned through proximal wick **236** (via internal wire passageway **236-1**). The conductor or heating element may be positioned around wire guide **237** and wire guide **238**. Thus, a conductor or heating element may run the through wire passageway **236-1**, around wire guides **237** and **238**, and then back through wire passageway **236-1** to return to approximately its point of origin. The heating element may, when personal vaporizer unit **100** is activated, heat proximal wick **236** in order to facilitate vaporization of a substance.

FIG. **59** is a perspective view of the proximal end wick assembly of FIGS. **54-58**. FIG. **59A** is a perspective view showing a heating element disposed through the proximal end wick and around the wire guides of FIGS. **54-58**. FIG. **59B** is a perspective view of the heating element of a personal vaporizer unit. FIG. **60** is a distal end view of the wick element and wire guides of FIGS. **54-58**. FIG. **61** is a cross-section of the wick element and wire guides along the cut line shown in FIG. **60**. As can be seen in FIG. **59A**, a conductor or heating element **239** may run through wire passageway **236-1**, around wire guides **237** and **238**, and then back through wire passageway **236-1** to return to approximately its point of origin.

In an embodiment, distal wicks **134**, **234**, and proximal wicks **136**, **236**, may be made of, or comprise, for example a porous ceramic. Distal wicks **134**, **234**, and proximal wicks **136**, **236**, may be made of, or comprise aluminum oxide, silicon carbide, magnesia partial stabilized zirconia, yttria tetragonal zirconia polycrystal, porous metal (e.g., steel, aluminum, platinum, titanium, and the like), ceramic coated porous metal, woven metal, spun metal, metal wool (e.g., steel wool), porous polymer, porous coated polymer, porous silica (i.e., glass), and/or porous Pyrex. Distal wicks **134**, **234**, and proximal wicks **136**, **236**, may be made of or comprise other materials that can absorb a substance to be vaporized.

The conductor or heating element that is disposed through proximal wick **136** or **236** may be made of, or comprise, for example: nickel chromium, iron chromium aluminum, stainless steel, gold, platinum, tungsten molybdenum, or a piezoelectric material. The conductor or heating element that is

14

disposed through proximal wick **136** can be made of, or comprise, other materials that become heated when an electrical current is passed through them.

FIG. **62** is a perspective view of a light pipe sleeve of a personal vaporizer unit. FIG. **63** is an end view of the light pipe sleeve of FIG. **62**. FIG. **64** is a cross-section of the light pipe sleeve along the cut line shown in FIG. **63**. Light pipe sleeve **140** is configured to be disposed within main shell **102**. Light pipe sleeve **140** is also configured to hold cartridge **150** and atomizer housing **132** or **232**. As discussed previously, light pipe sleeve **140** is configured to conduct light entering the proximal end of light pipe sleeve **140** (e.g., from LEDs **125-127**) to the distal end of light pipe sleeve **140**. Typically, the light exiting the distal end of light pipe sleeve **140** will be visible from the exterior of personal vaporizer **100**. The light exiting the distal end of light pipe sleeve **140** may be diffused by cartridge **150**. The light exiting the distal end of light pipe sleeve **140** may illuminate characters and/or symbols drawn, printed, written, or embossed, etc., in an end of cartridge **150**. In an embodiment, light exiting light pipe sleeve **140** may illuminate a logo, characters and/or symbols cut through outer main shell **102**. In an embodiment, light pipe sleeve **140** is made of, or comprises, a translucent acrylic plastic.

FIG. **65** is a perspective view of a cartridge of a personal vaporizer unit. FIG. **66** is a proximal end view of the cartridge of FIG. **65**. FIG. **67** is a side view of the cartridge of FIG. **65**. FIG. **68** is a top view of the cartridge of FIG. **65**. FIG. **69** is a cross-section of the cartridge along the cut line shown in FIG. **66**. As shown in FIGS. **65-69**, cartridge **150** comprises a hollow cylinder section with at least one exterior flat surface **158**. The flat surface **158** forms, when cartridge **150** is inserted into the distal end of personal vaporizer unit **100**, an open space between the exterior surface of the cartridge and an interior surface of light pipe sleeve **140**. This space defines a passage for air to be drawn from outside personal vaporizer unit **100**, through personal vaporizer unit **100** to be inhaled by the user along with the vaporized substance. This space also helps define the volume of air drawn into personal vaporizer unit **100**. By defining the volume of air typically drawn into the unit, different mixtures of vaporized substance to air may be produced.

The hollow portion of cartridge **150** is configured as a reservoir to hold the substance to be vaporized by personal vaporizer unit **100**. The hollow portion of cartridge **150** holds the substance to be vaporized in direct contact with distal wick **134** or **234**. This allows distal wick **134** or **234** to become saturated with the substance to be vaporized. The area of distal wick **134** or **234** that is in direct contact with the substance to be vaporized may be varied in order to deliver different doses of the substance to be vaporized. For example, cartridges **150** with differing diameter hollow portions may be used to deliver different doses of the substance to be vaporized to the user.

Cartridge **150** may be configured to confine the substance to be vaporized by a cap or seal (not shown) on the proximal end. This cap or seal may be punctured by the end of atomizer housing **132**, or the pointed end **234-1** of proximal wick **234**.

When inserted into personal vaporizer unit **100**, cartridge standoff **157** define an air passage between the end of light pipe sleeve **140** and main shell **102**. This air passage allows air to reach the air passage defined by flat surface **158**.

The hollow portion of cartridge **150** also includes one or more channels **154**. The end of these channels are exposed to air received via the air passage(s) defined by flat surface

15

158. These channels allow air to enter the hollow portion of cartridge 150 as the substance contained in cartridge 150 is drawn into a distal wick 134 or 234. Allowing air to enter the hollow portion of cartridge 150 as the substance contained in cartridge 150 is removed prevents a vacuum from forming inside cartridge 150. This vacuum could prevent the substance contained in cartridge 150 from being absorbed into distal wick 134 or 234.

In an embodiment, cartridge 150 may be at least partly translucent. Thus cartridge 150 may act as a light diffuser so that light emitted by one or more of LEDs 125-127 is visible external to personal vaporizer unit 100.

FIG. 70 is a side view of a battery of a personal vaporizer unit. FIG. 71 is an end view of the battery of FIG. 70. FIG. 72 is a perspective view of a battery support of a personal vaporizer unit. As can be seen in FIG. 72, battery support 106 does not form a complete cylinder that completely surrounds battery 104. This missing portion of a cylinder forms a passageway that allows air and the vaporized substance to pass by the battery from the atomizer assembly to the mouthpiece 116 so that it may be inhaled by the user.

FIG. 73 is a top perspective view of a personal vaporizer unit case. FIG. 74 is a bottom perspective view of a personal vaporizer unit case. Personal vaporizer case 500 is configured to hold one or more personal vaporizer units 100. Personal vaporizer case 500 includes a connector 510 to interface to a computer. This connector allows case 500 to transfer data from personal vaporizer unit 100 to a computer via connector 510. Case 500 may also transfer data from personal vaporizer unit 100 via a wireless interface. This wireless interface may comprise an infrared (IR) transmitter, a Bluetooth interface, an 802.11 specified interface, and/or communicate with a cellular telephone network. Data from a personal vaporizer unit 100 may be associated with an identification number stored by personal vaporizer unit 100. Data from personal vaporizer unit 100 may be transmitted via the wireless interface in association with the identification number.

Personal vaporizer case 500 includes a battery that may hold charge that is used to recharge a personal vaporizer unit 100. Recharging of personal vaporizer unit 100 may be managed by a charge controller that is part of case 500.

When case 500 is holding a personal vaporizer unit 100, at least a portion of the personal vaporizer unit 100 is visible from the outside of case 500 to allow a light emitted by personal vaporizer unit 100 to provide a visual indication of a state of personal vaporizer unit 500. This visual indication is visible outside of case 500.

Personal vaporizer unit 100 is activated by a change in impedance between two conductive surfaces. In an embodiment, these two conductive surfaces are part of main shell 102 and mouthpiece 116. These two conductive surfaces may also be used by case 500 to charge battery 104. These two conductive surfaces may also be used by case 500 to read data out of personal vaporizer unit 100.

In an embodiment, when a user puts personal vaporizer unit 100 in his/her mouth and provides "suction," air is drawn into personal vaporizer unit 100 through a gap between the end of main shell 102 and cartridge 150. In an embodiment, this gap is established by standoffs 157. Air travels down galley(s) formed by flat surface(s) 158 and the inner surface of light pipe sleeve 140. The air then reaches a "ring" shaped galley between atomizer housing 132, cartridge 150, and light pipe sleeve 140. Air travels to distal wick 134 via one or more holes 132-1, in chamfered surface(s) 132-3. Air travels to distal wick 234 via one or more holes 232-1, in chamfered surface(s) 232-3. Air is also

16

allowed to enter cartridge 150 via one or more channels 154. This air entering cartridge 150 via channels 154 "back fills" for the substance being vaporized which enters distal wick 134. The substance being vaporized is held in direct contact with distal wick 134 or 234 by cartridge 150. The substance being vaporized is absorbed by and may saturate distal wick 134 or 234 and proximal wick 136 or 236.

The incoming air drawn through holes 132-1 displaces from saturated distal wick 134 the substance being vaporized. The displaced substance being vaporized is pulled from wick elements 134 into a cavity between distal wick 134 and 136. This cavity may also contain a heating element that has been heated to between 150-200° C. The displaced substance being vaporized is pulled from wick elements 134 in small (e.g., atomized) droplets. These atomized droplets are vaporized by the heating element.

In an embodiment, when a user puts personal vaporizer unit 100 in his/her mouth and provides "suction," air is drawn into personal vaporizer unit 100 through a gap between the end of main shell 102 and cartridge 150. In an embodiment, this gap is established by standoffs 157. Air travels down galley(s) formed by flat surface(s) 158 and the inner surface of light pipe sleeve 140. The air then reaches a "ring" shaped galley between atomizer housing 232, cartridge 150, and light pipe sleeve 140. Air travels to proximal wick 234 via one or more holes 232-1, in chamfered surface(s) 232-1. Air is also allowed to enter cartridge 150 via one or more channels 154. This air entering cartridge 150 via channels 154 "back fills" for the substance being vaporized which enters proximal wick 234. The substance being vaporized is held in direct contact with proximal wick 234 by cartridge 150. The substance being vaporized is absorbed by and may saturate distal wick 243 and proximal wick 236.

The incoming air drawn through holes 232-1 displaces from saturated proximal wick 234 the substance being vaporized. The displaced substance being vaporized is pulled from wick elements 234 into a cavity between wick distal wick 234 and proximal wick 236. This cavity may also contain a heating element that has been heated to between 150-200° C. The displaced substance being vaporized is pulled from distal wick 234 in small (e.g., atomized) droplets. These atomized droplets are vaporized by the heating element.

In both of the previous two embodiments, the vaporized substance and air are drawn down a galley adjacent to battery 104, through mouthpiece insulator 112, mouthpiece 116, and mouthpiece cover 114. After exiting personal vaporizer unit 100, the vapors may be inhaled by a user.

The systems, controller, and functions described above may be implemented with or executed by one or more computer systems. The methods described above may be stored on a computer readable medium. Personal vaporizer unit 100 and case 500 may be, comprise, or include computers systems. FIG. 75 illustrates a block diagram of a computer system. Computer system 600 includes communication interface 620, processing system 630, storage system 640, and user interface 660. Processing system 630 is operatively coupled to storage system 640. Storage system 640 stores software 650 and data 670. Processing system 630 is operatively coupled to communication interface 620 and user interface 660. Computer system 600 may comprise a programmed general-purpose computer. Computer system 600 may include a microprocessor. Computer system 600 may comprise programmable or special purpose circuitry.

Computer system **600** may be distributed among multiple devices, processors, storage, and/or interfaces that together comprise elements **620-670**.

Communication interface **620** may comprise a network interface, modem, port, bus, link, transceiver, or other communication device. Communication interface **620** may be distributed among multiple communication devices. Processing system **630** may comprise a microprocessor, micro-controller, logic circuit, or other processing device. Processing system **630** may be distributed among multiple processing devices. User interface **660** may comprise a keyboard, mouse, voice recognition interface, microphone and speakers, graphical display, touch screen, or other type of user interface device. User interface **660** may be distributed among multiple interface devices. Storage system **640** may comprise a disk, tape, integrated circuit, RAM, ROM, network storage, server, or other memory function. Storage system **640** may be a computer readable medium. Storage system **640** may be distributed among multiple memory devices.

Processing system **630** retrieves and executes software **650** from storage system **640**. Processing system may retrieve and store data **670**. Processing system may also retrieve and store data via communication interface **620**. Processing system **650** may create or modify software **650** or data **670** to achieve a tangible result. Processing system may control communication interface **620** or user interface **670** to achieve a tangible result. Processing system may retrieve and execute remotely stored software via communication interface **620**.

Software **650** and remotely stored software may comprise an operating system, utilities, drivers, networking software, and other software typically executed by a computer system. Software **650** may comprise an application program, applet, firmware, or other form of machine-readable processing instructions typically executed by a computer system. When executed by processing system **630**, software **650** or remotely stored software may direct computer system **600** to operate as described herein.

The above description and associated figures teach the best mode of the invention. The following claims specify the scope of the invention. Note that some aspects of the best mode may not fall within the scope of the invention as specified by the claims. Those skilled in the art will appreciate that the features described above can be combined in various ways to form multiple variations of the invention. As a result, the invention is not limited to the specific embodiments described above, but only by the following claims and their equivalents.

What is claimed is:

1. A personal vaporizing unit having a proximal end configured to be placed in a human mouth and a distal end, said personal vaporizing unit comprising:

a cartridge having a first end and a second end and holding a fluid to be vaporized into a mixture of air and vaporized fluid;

a chamber open at the distal end of the personal vaporizing unit, the chamber configured to receive the cartridge, at least one space between an exterior surface of said cartridge and an interior surface of said chamber defining a passage for outside air without said vaporized mixture being drawn from outside said personal vaporizing unit at the distal end, wherein said outside air without said vaporized mixture is drawn along said passage from said distal end to said second end; and, a porous wick that breaks a seal on said sealed cartridge to allow said fluid to be vaporized into said vaporized

mixture, wherein said porous wick absorbs a portion of said fluid from said cartridge and passes it for vaporization.

2. The personal vaporizing unit of claim **1**, wherein at least an end surface of said cartridge is translucent to diffuse light produced internally to said personal vaporizing unit.

3. The personal vaporizing unit of claim **1**, wherein said chamber is configured to hold said cartridge to place said porous wick in direct contact with said fluid to facilitate said fluid passing through said porous wick.

4. The personal vaporizing unit of claim **3**, further comprising a heating element, wherein said wick exposes said received portion of said fluid to said heating element.

5. The personal vaporizing unit of claim **1**, wherein said at least one space is created by a flat surface on said cartridge and a round inner diameter of said chamber.

6. The personal vaporizing unit of claim **1**, wherein air is drawn from outside said personal vaporizing unit to said at least one space through a space determined by at least one stand-off that creates a space between said first end and said distal end of said personal vaporizing unit.

7. The personal vaporizing unit of claim **1**, wherein said cartridge has at least one anti-vacuum channel in an interior surface that allows air into a cartridge chamber holding said fluid to be vaporized.

8. The personal vaporizing unit of claim **1**, wherein the porous wick comprises a porous ceramic, porous metal, ceramic coated porous metal, woven metal, spun metal, metal wool, porous polymer, porous coated polymer, porous silica, or porous Pyrex material.

9. The personal vaporizing unit of claim **1**, wherein the air passes through said porous wick by capillary action of said porous wick.

10. A personal vaporizing unit having a proximal end configured to be placed in a human mouth and a distal end, the personal vaporizing unit comprising:

a distal end chamber;

a porous wick comprising a pointed end; and

a cartridge comprising:

a housing having a first end and a second end, the housing configured to have the second end inserted in an opening at the distal end chamber, said housing configured to hold a fluid to be vaporized into a vaporized mixture of air and vaporized fluid said housing and an interior surface of said distal end chamber forming, when said cartridge is inserted in said distal end chamber, at least one space between an exterior surface of said housing and said interior surface of said distal end chamber that defines a passage for outside air without said vaporized mixture to be drawn from outside and along said passage from said distal end to said second end; and,

a seal that holds said fluid inside said housing wherein said pointed end of said porous wick punctures the seal when said cartridge is installed into said distal end chamber, further wherein said porous wick absorbs a portion of said fluid and said fluid is removed by capillary action of said porous wick.

11. The personal vaporizing unit of claim **10**, wherein said housing further comprises:

at least one anti-vacuum channel formed by an interior surface of said housing that, after said seal is punctured, allows air into said cartridge to replace said fluid that is removed from said cartridge.

12. The personal vaporizing unit of claim **11**, wherein said wick is in contact with said fluid when the seal is punctured.

13. The personal vaporizing unit of claim 10, wherein at least an end surface of said housing is translucent to diffuse light produced internally to said personal vaporizing unit.

14. The personal vaporizing unit of claim 10, wherein said at least one space is created by a flat surface on said housing and a round inner diameter of said interior surface of said personal vaporizing unit. 5

15. The personal vaporizing unit of claim 10, further comprising:

at least one stand-off that, when said cartridge is inserted 10
in said personal vaporizing unit, creates a space
between said distal end of said personal vaporizing unit
and said first end of said housing.

16. The personal vaporizing unit of claim 10, wherein said porous wick comprises a porous ceramic, porous metal, 15
ceramic coated porous metal, woven metal, spun metal,
metal wool, porous polymer, porous coated polymer, porous
silica, or porous pyrex material.

17. The personal vaporizing unit of claim 10, wherein an interior surface of said housing is configured to contact said 20
personal vaporizer unit to form a contact seal that prevents
said fluid from flowing into said at least one space.

* * * * *