



US009327936B2

(12) **United States Patent**
Awano

(10) **Patent No.:** **US 9,327,936 B2**
(45) **Date of Patent:** **May 3, 2016**

(54) **SHEET FOLDING DEVICE, POST-PROCESSING DEVICE, AND IMAGE FORMING SYSTEM**

20/02; B65H 2801/31; B65H 29/12; B65H 39/16; B65H 45/00; B65H 45/04; B65H 45/22; B65H 45/221; B65H 2404/11; B65H 45/18; B65H 45/16; B65H 2404/13

(71) Applicant: **FUJI XEROX CO., LTD.**, Tokyo (JP)

USPC 358/1.12, 1.1
See application file for complete search history.

(72) Inventor: **Hiroaki Awano**, Kanagawa (JP)

(73) Assignee: **FUJI XEROX CO., LTD.**, Tokyo (JP)

(56) **References Cited**

(*) Notice: Subject to any disclaimer, the term of this patent is extended or adjusted under 35 U.S.C. 154(b) by 0 days.

U.S. PATENT DOCUMENTS

5,876,027 A * 3/1999 Fukui et al. 270/51
2003/0069119 A1 * 4/2003 Trovinger B65H 45/18
493/431

(21) Appl. No.: **14/341,144**

(Continued)

(22) Filed: **Jul. 25, 2014**

FOREIGN PATENT DOCUMENTS

(65) **Prior Publication Data**

US 2015/0183613 A1 Jul. 2, 2015

JP A-9-2735 1/1997
JP A-10-194587 7/1998

(Continued)

(30) **Foreign Application Priority Data**

Dec. 27, 2013 (JP) 2013-273449

OTHER PUBLICATIONS

Office Action issued in Japanese Patent Application No. 2013-273449 dated Aug. 26, 2014 (with translation).

(51) **Int. Cl.**

B65H 45/16 (2006.01)
G06K 15/00 (2006.01)
B65H 45/18 (2006.01)

Primary Examiner — Iriana Cruz

(74) *Attorney, Agent, or Firm* — Oliff PLC

(52) **U.S. Cl.**

CPC **B65H 45/18** (2013.01); **B65H 2404/11** (2013.01); **B65H 2404/13** (2013.01); **B65H 2801/27** (2013.01)

(57) **ABSTRACT**

Provided is a sheet folding device including a folding roll that is rotatably provided and includes a large diameter portion of which a diameter is greater than a diameter of another portion, and performs a folding process while pressing the large diameter portion onto a sheet, and a contact portion displacement unit that makes a position of a contact portion that is a portion coming into contact with the large diameter portion in the sheet when the sheet on which the folding process has been performed by the folding roll passes through the folding roll again different from a position of the contact portion when the sheet passes through the folding roll for the last time.

(58) **Field of Classification Search**

CPC B65H 2220/01; B65H 2220/02; B65H 2801/27; B65H 2701/13212; B65H 37/04; B65H 2301/51232; B65H 2511/10; B65H 45/142; B65H 2511/415; B65H 45/30; B65H 2511/216; B65H 2511/514; B65H 2513/40; B65H 2513/41; B65H 2513/42; B65H 2301/163; B65H 2301/23; B65H 2301/36212; B65H 2405/50; B65H 2511/224; B65H 2701/1311; B65H 37/00; B65H 5/062; B65H

8 Claims, 18 Drawing Sheets

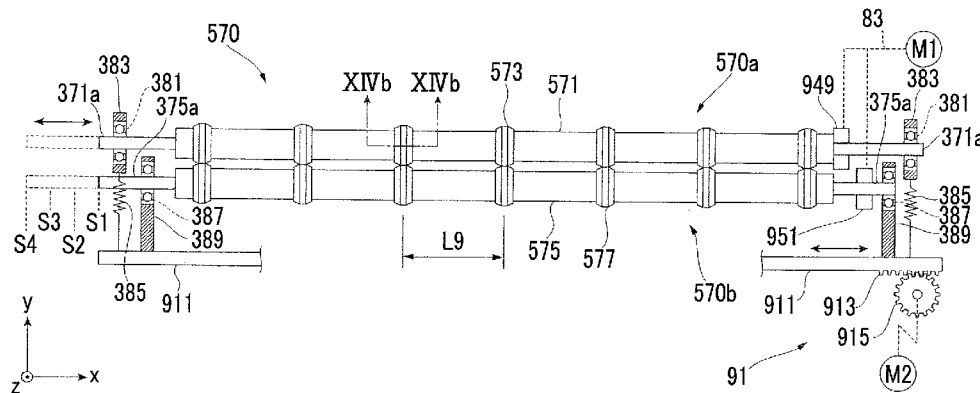

(56)

References Cited

2013/0049278 A1* 2/2013 Tsuchiya G03G 15/6544
270/45

U.S. PATENT DOCUMENTS

2008/0001338 A1* 1/2008 Kotani B65H 45/18
270/37
2008/0182740 A1* 7/2008 Fukasawa B65H 45/18
493/405
2009/0057363 A1* 3/2009 Belleculee et al. 226/174
2012/0028779 A1* 2/2012 Sugizaki B65H 45/18
493/454

FOREIGN PATENT DOCUMENTS

JP A-2001-335234 12/2001
JP A-2007-45531 2/2007
JP A-2009-91158 4/2009

* cited by examiner

FIG. 1

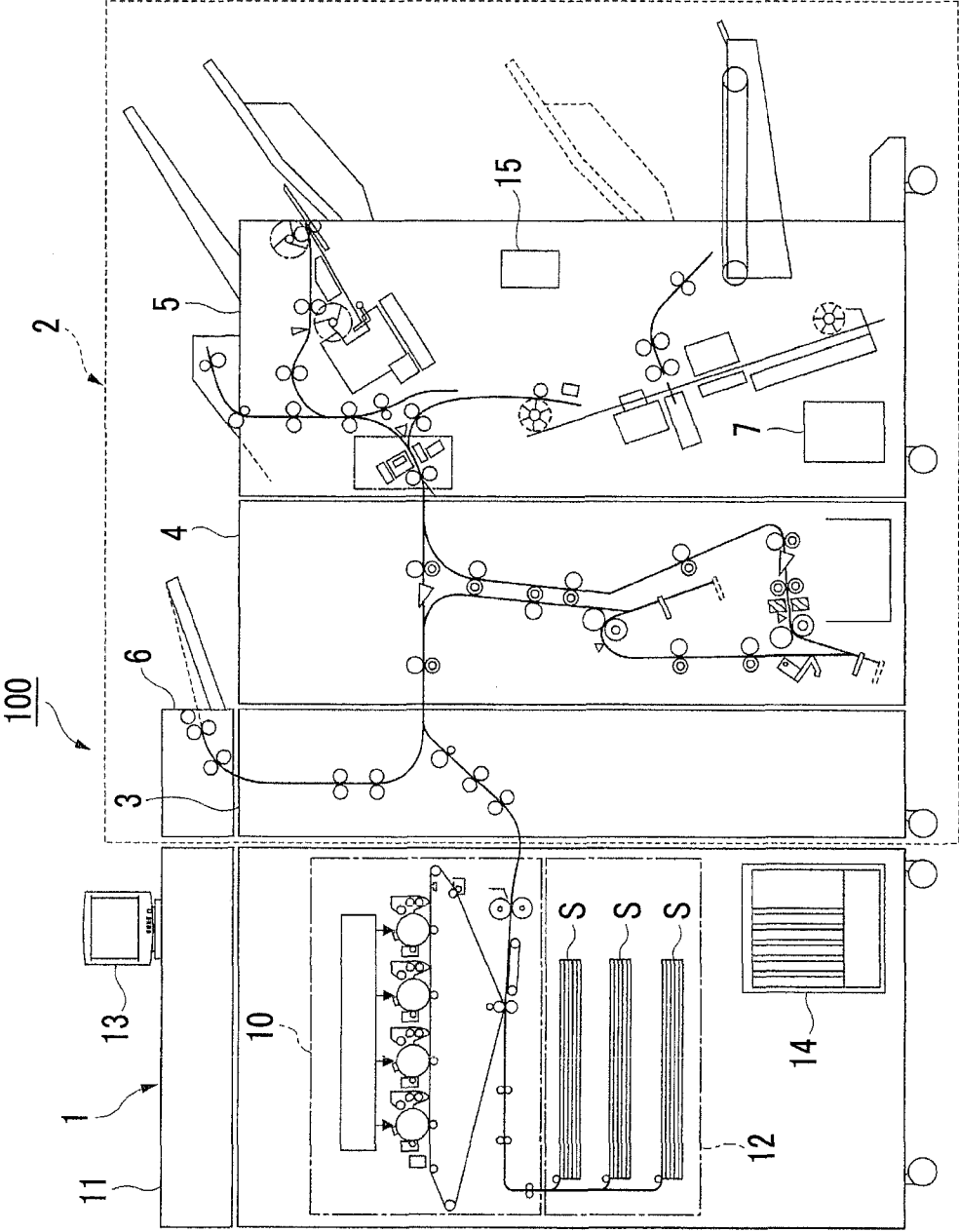

FIG. 2

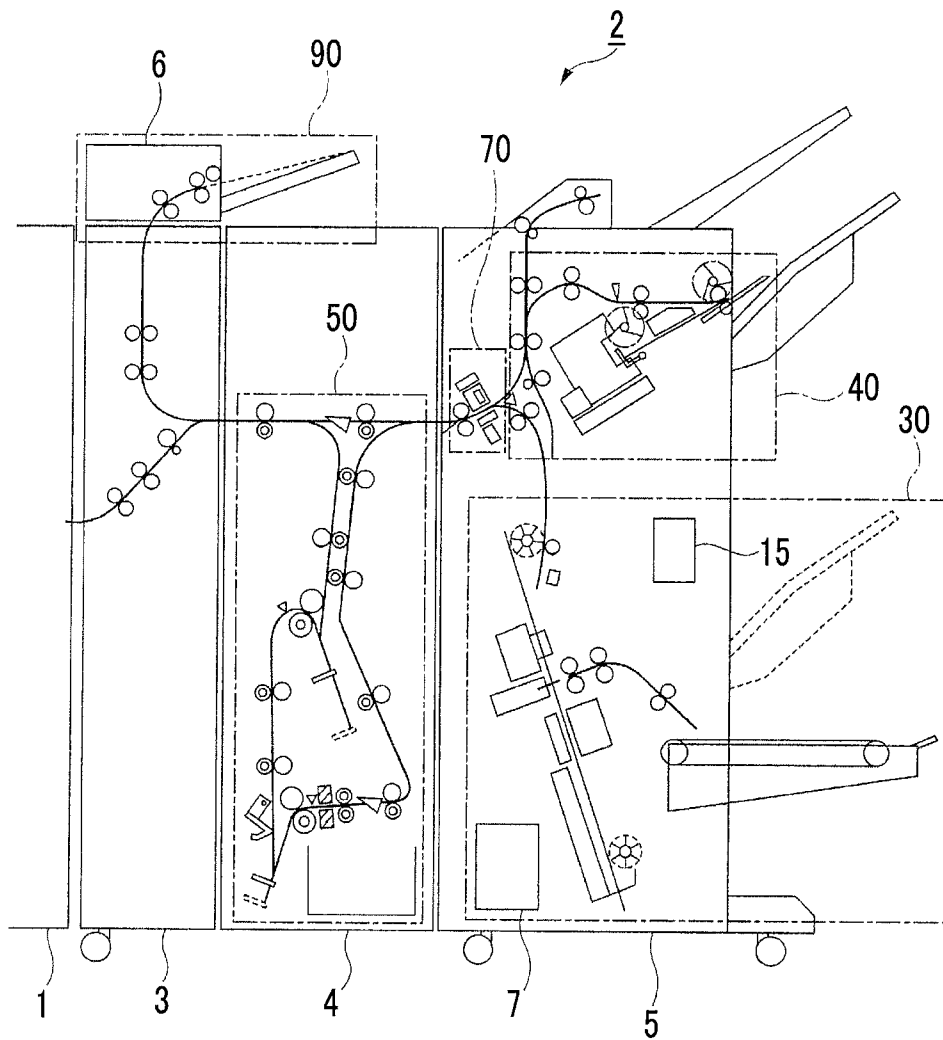

FIG. 3

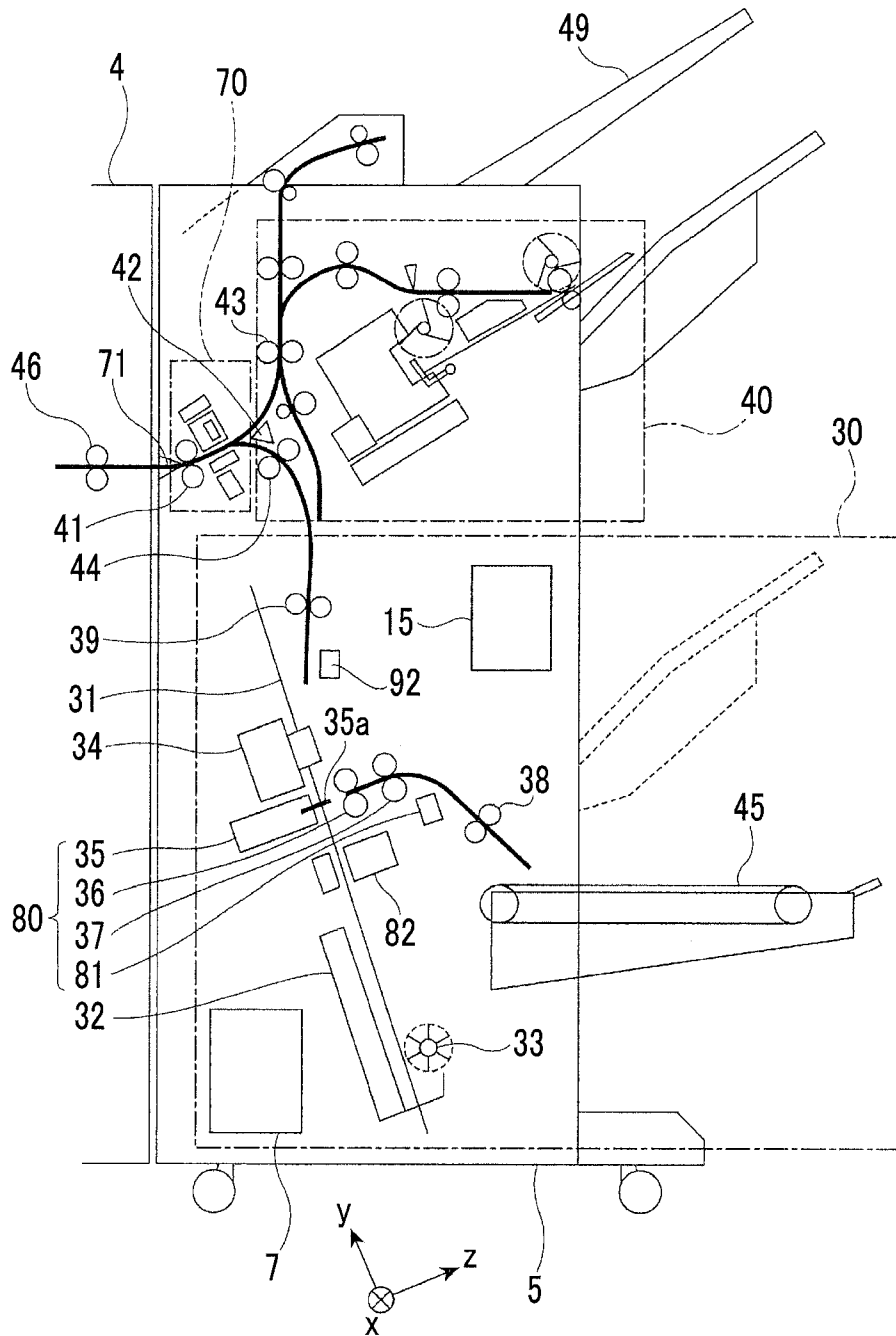

FIG. 4

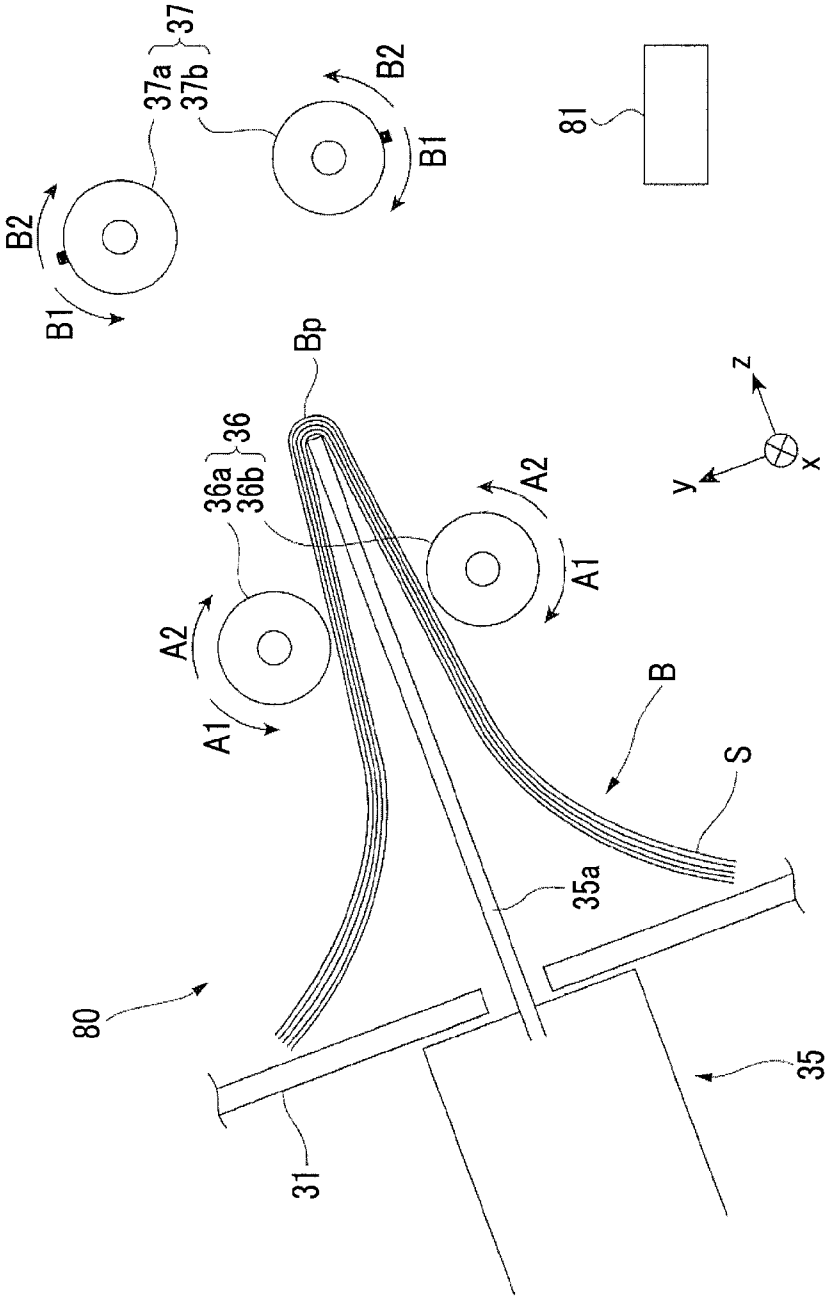

FIG. 5

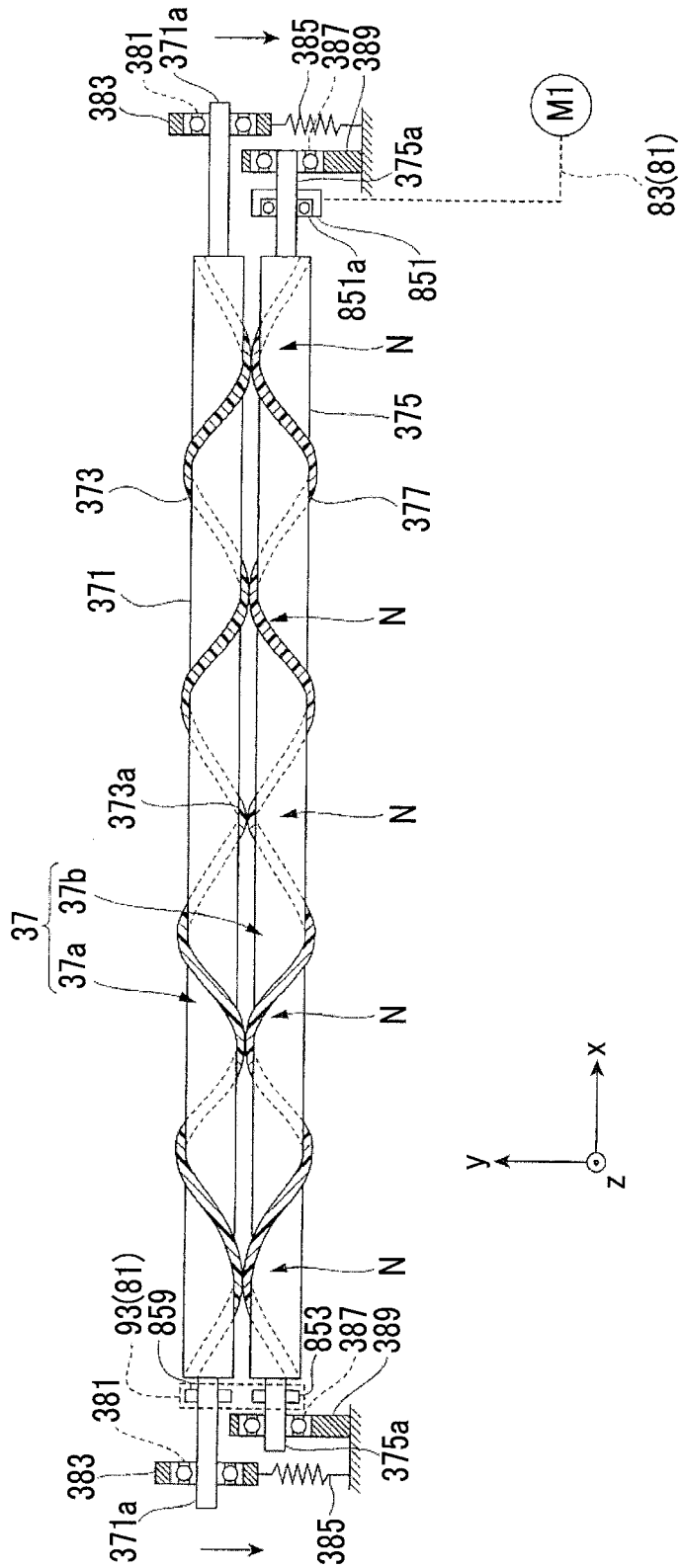

FIG. 6A

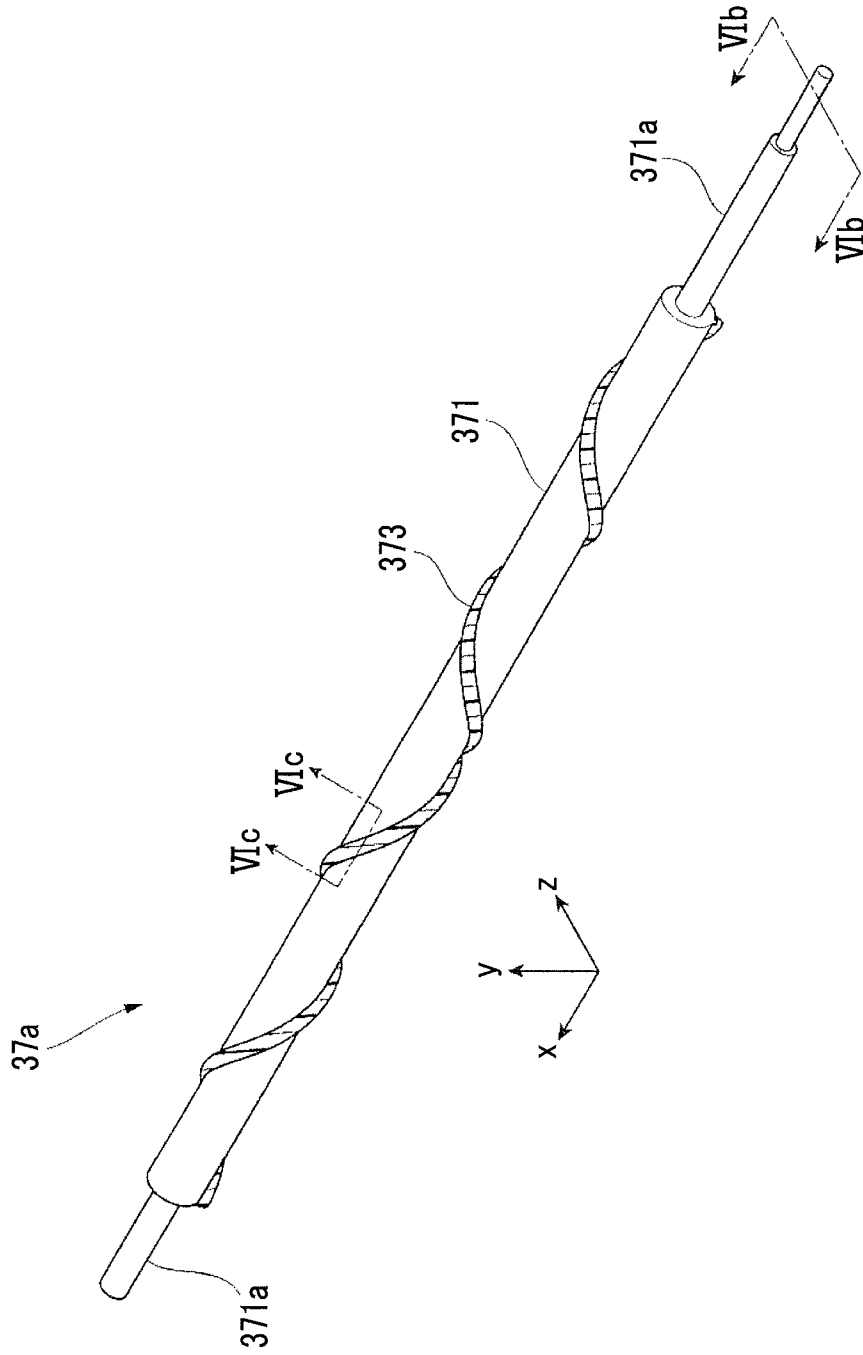

FIG. 6B

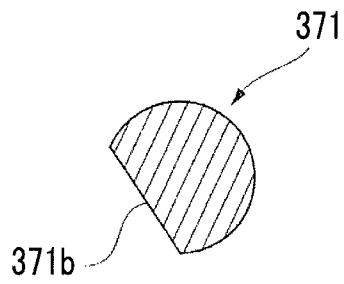

FIG. 6C

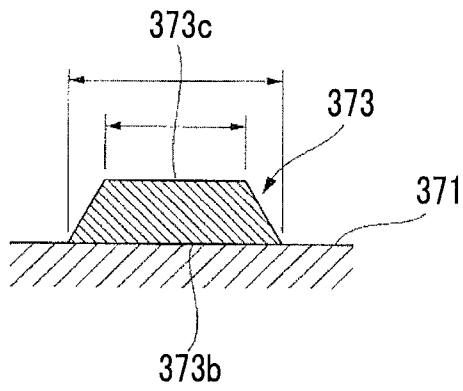

FIG. 7A

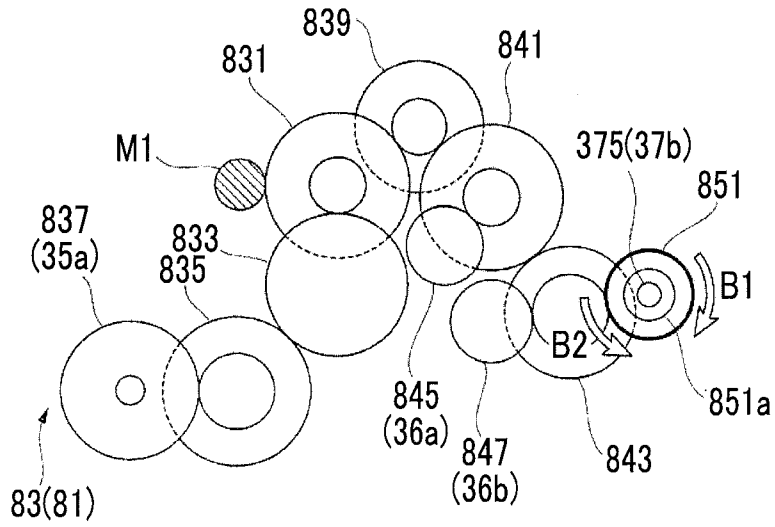

FIG. 7B

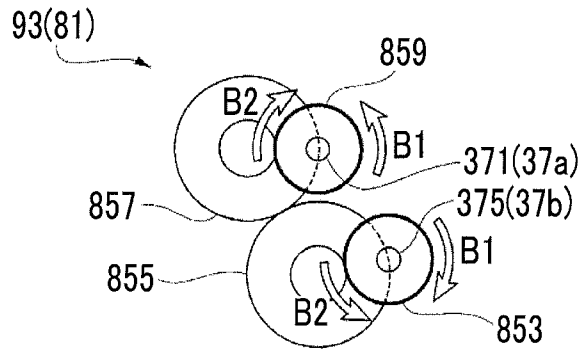

FIG. 7C

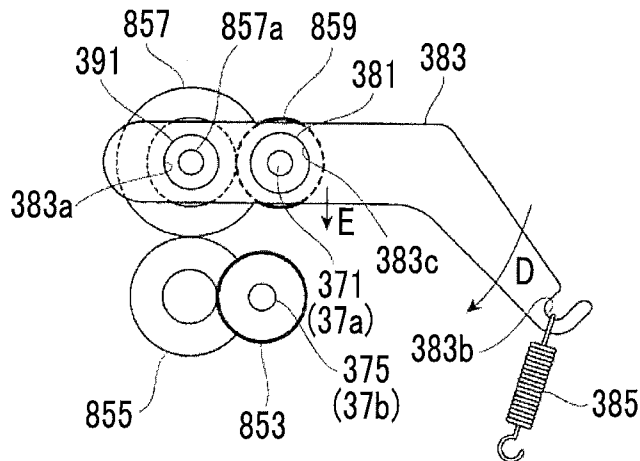

FIG. 8

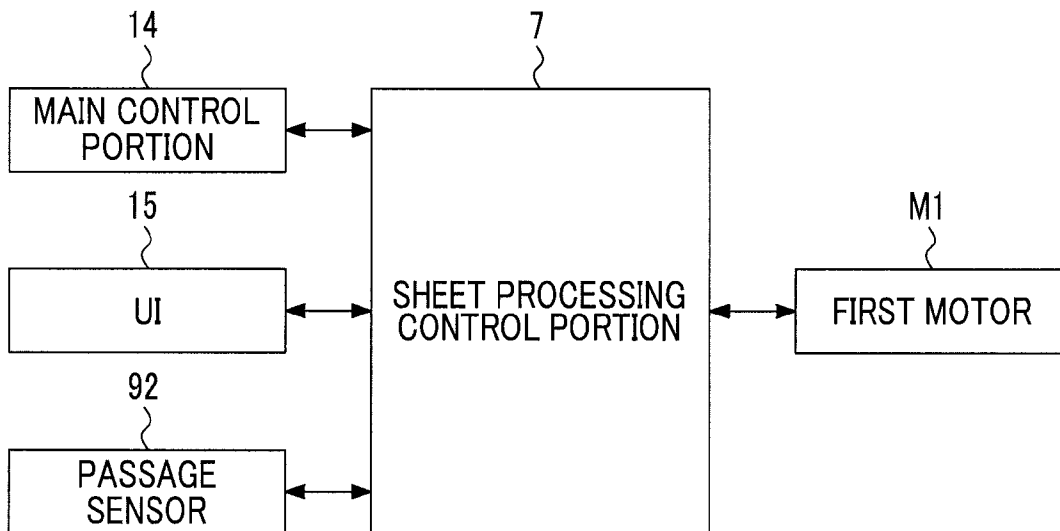

FIG. 9A

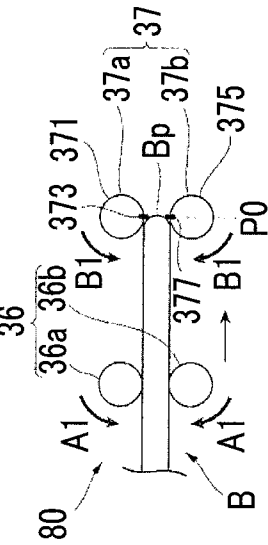

FIG. 9D

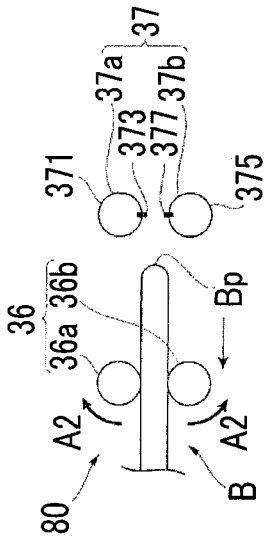

FIG. 9E

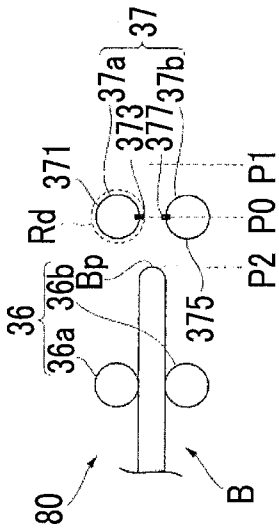

FIG. 9F

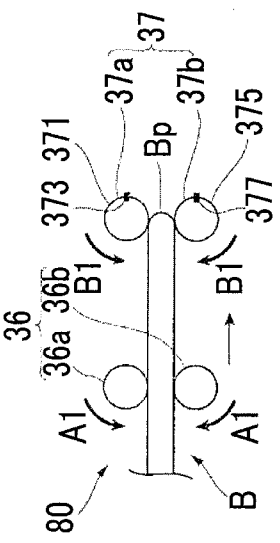

FIG. 9B

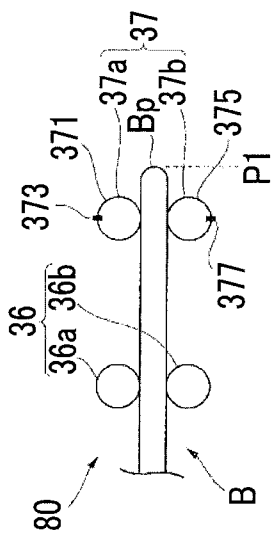

FIG. 9C

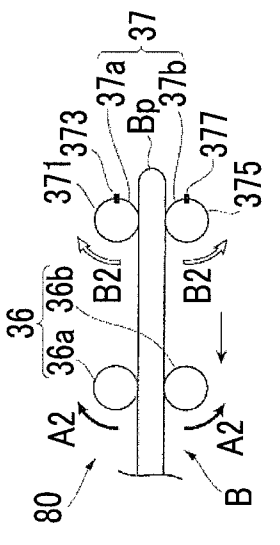

FIG. 10A

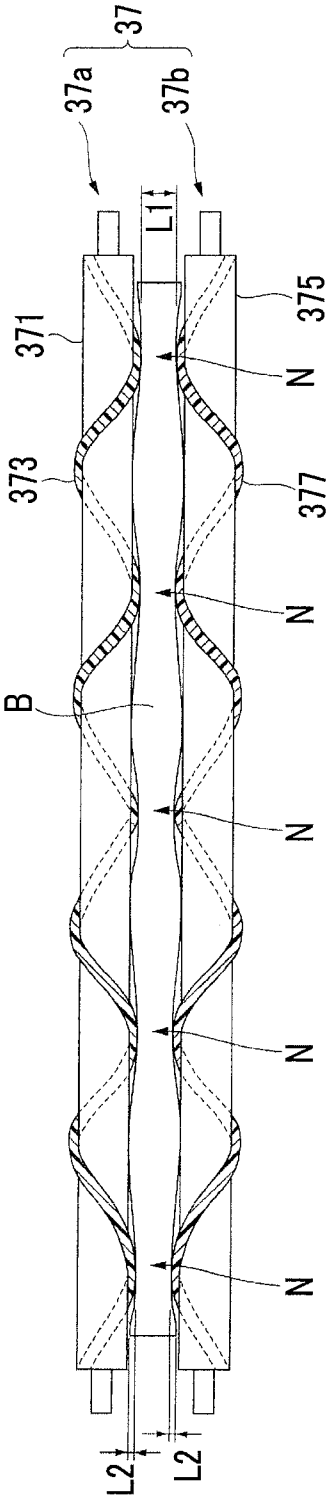

FIG. 10B

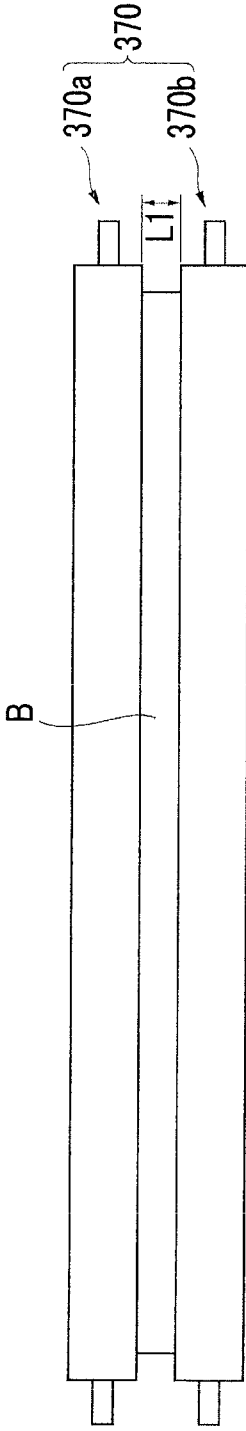

FIG. 10C

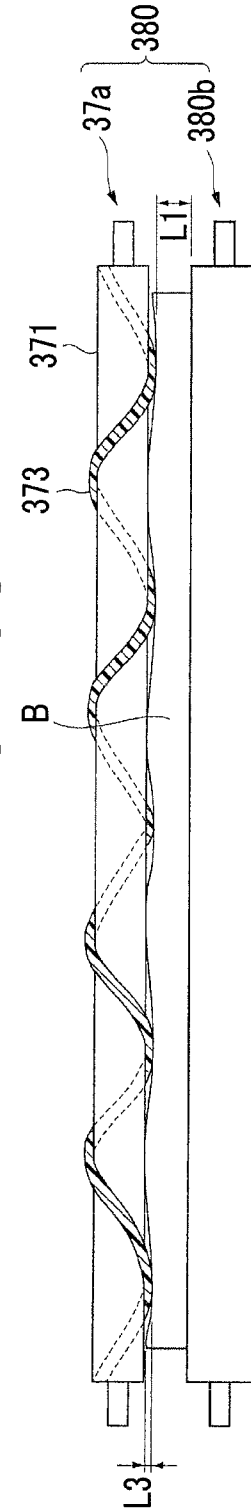

FIG. 11

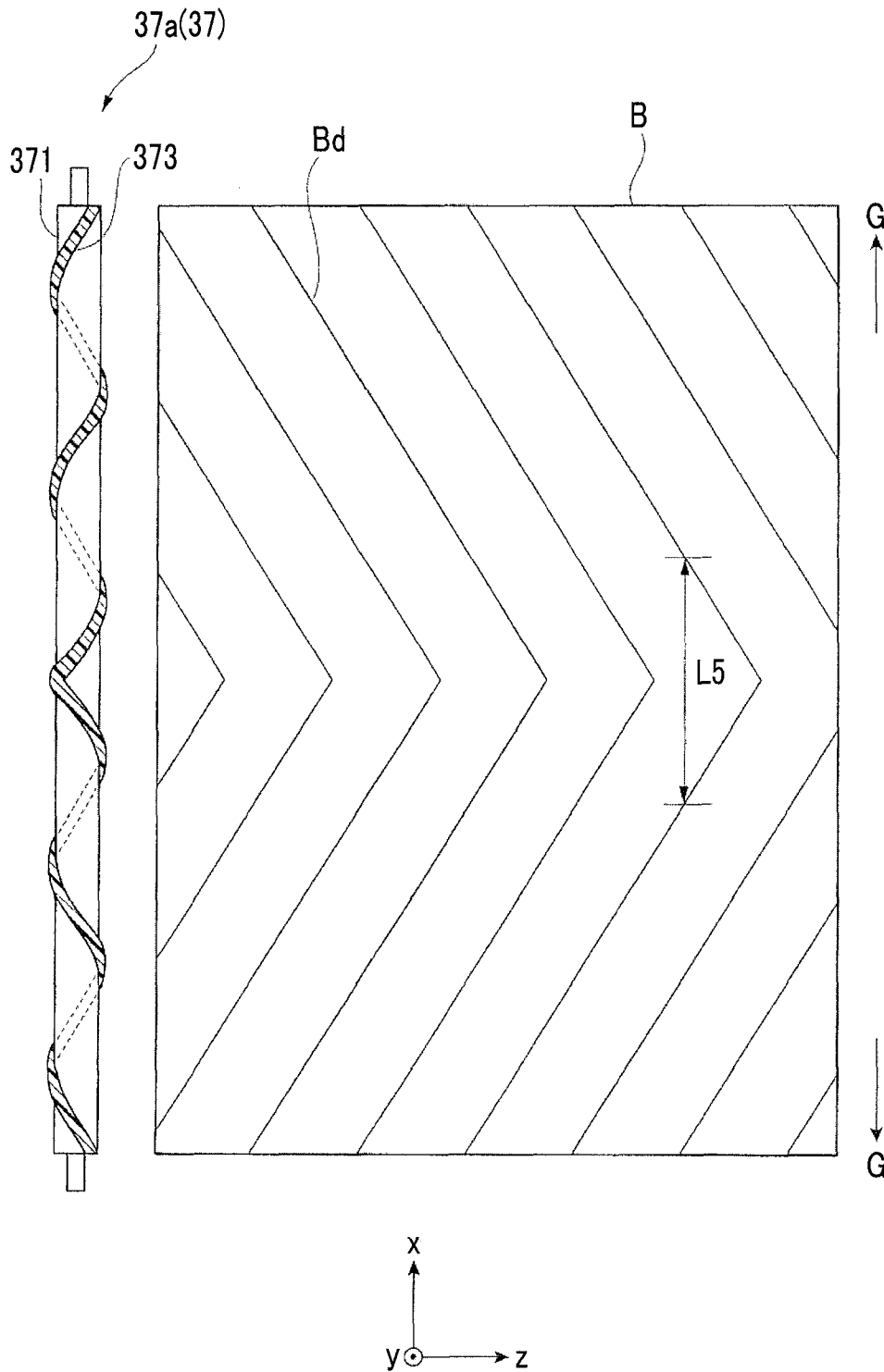

FIG. 12A

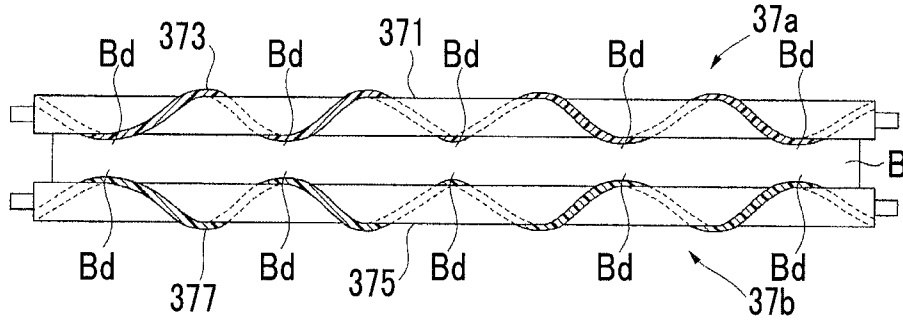

FIG. 12B

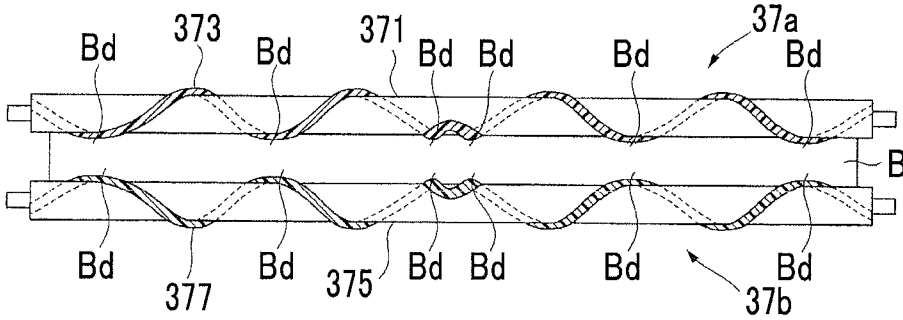

FIG. 12C

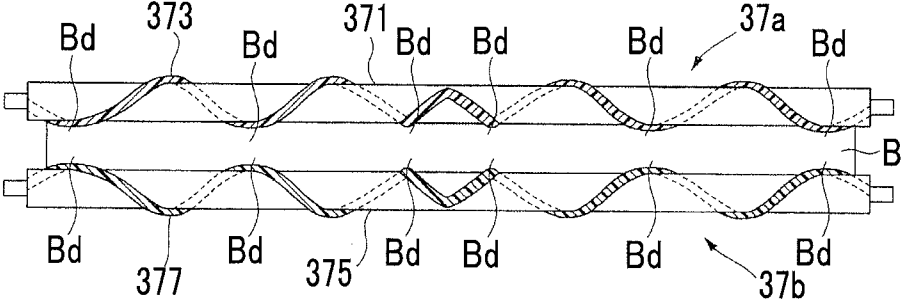

FIG. 12D

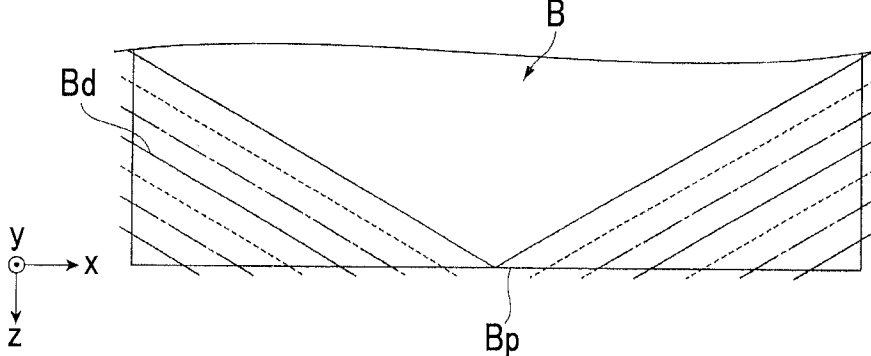

FIG. 13

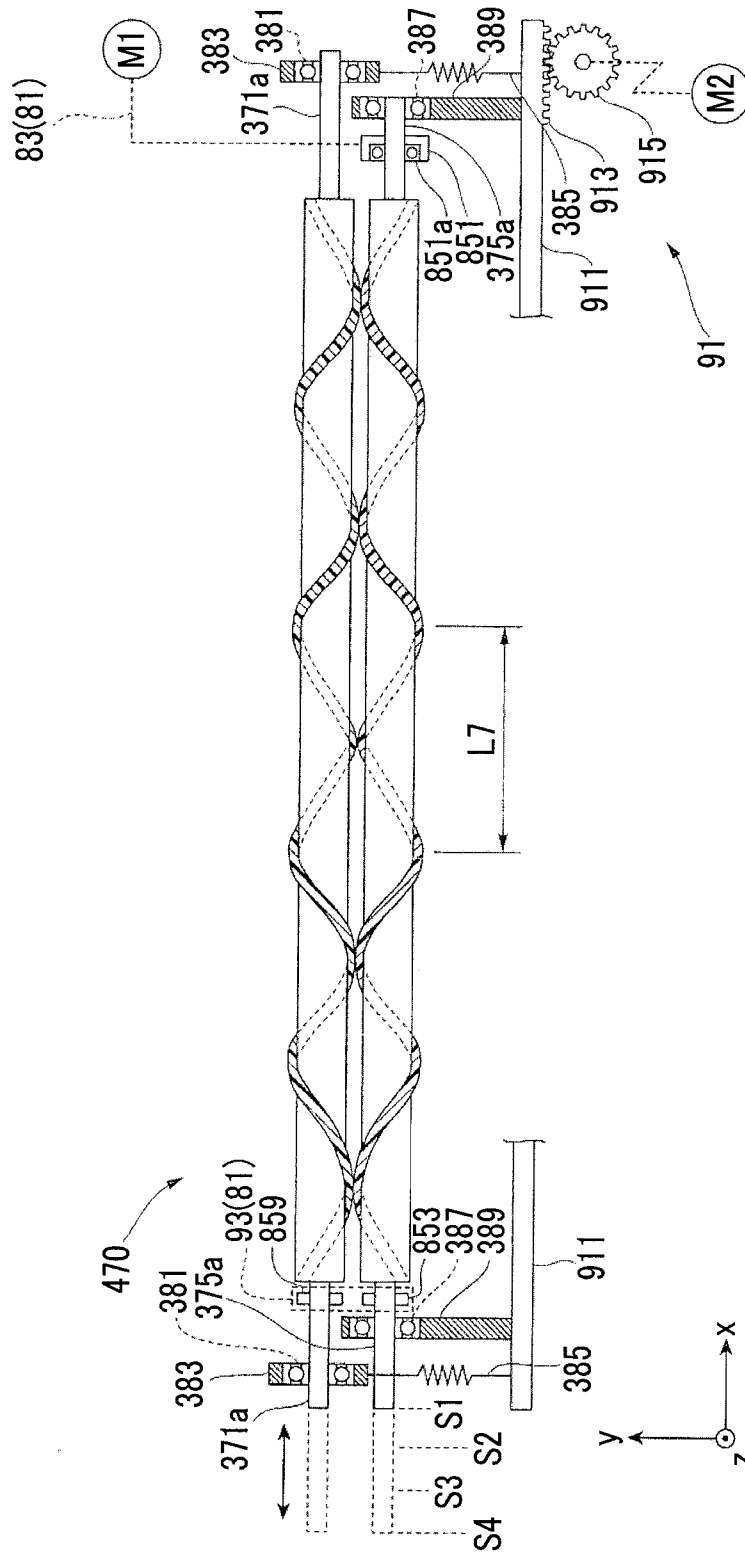

FIG. 14A

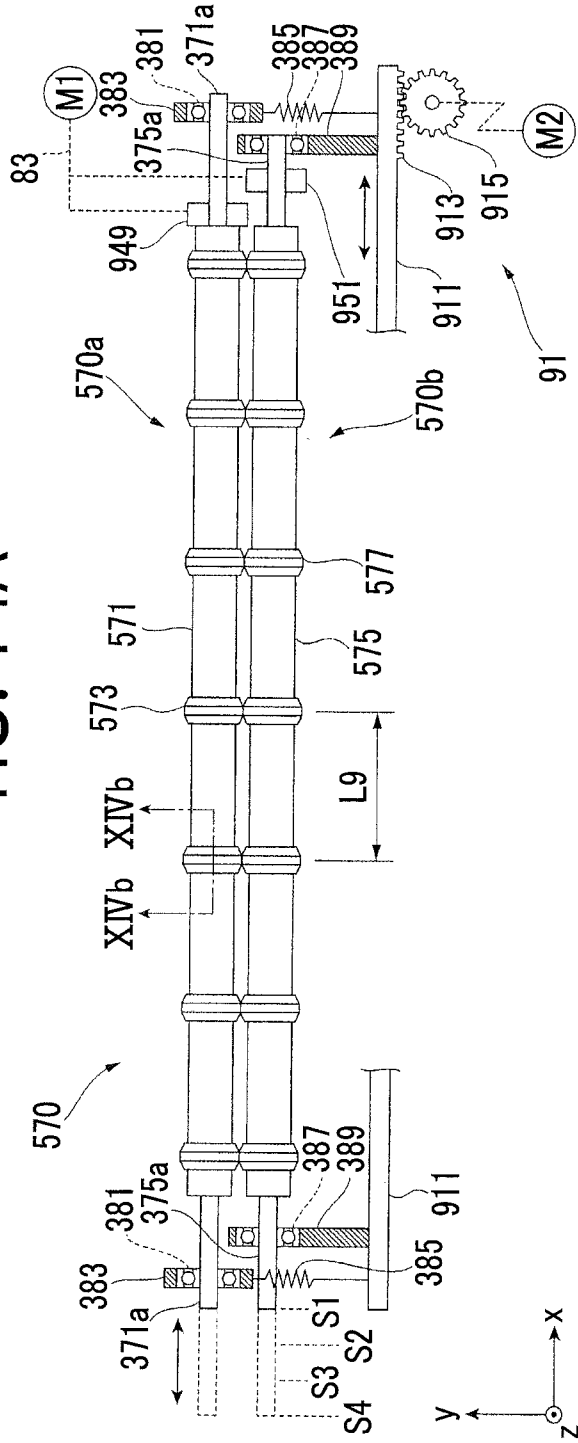

FIG. 14B

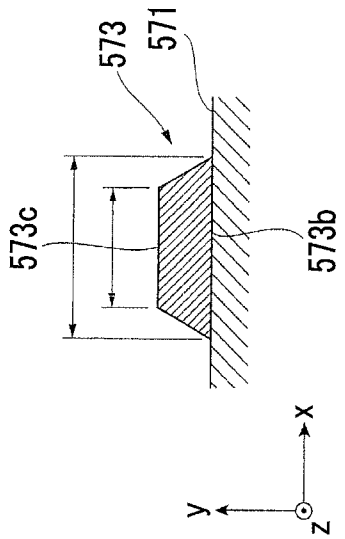

FIG. 15A

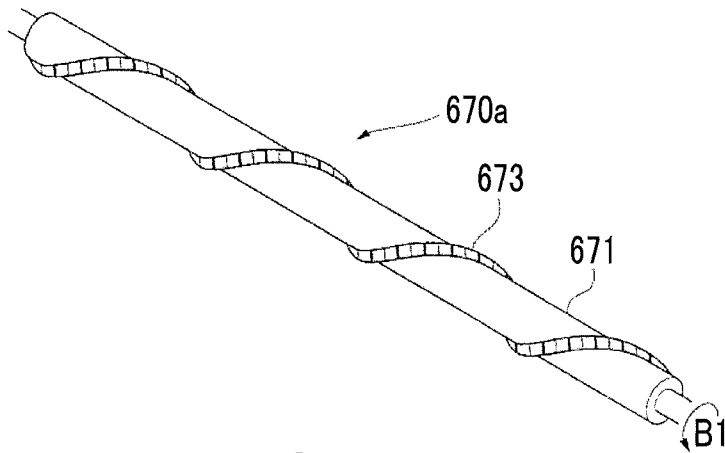

FIG. 15B

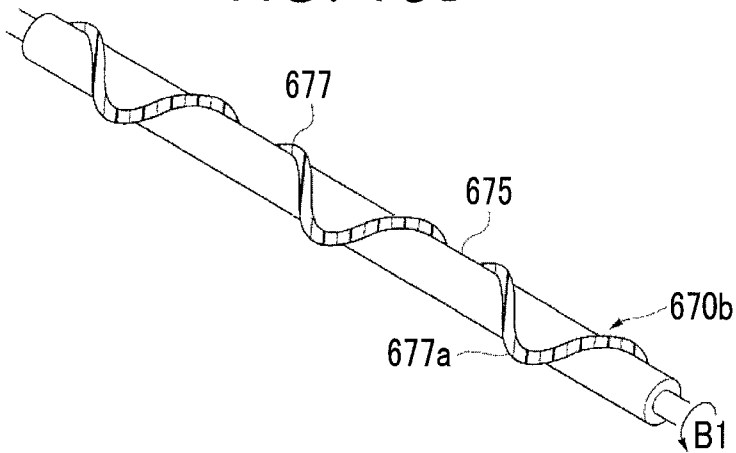

FIG. 15C

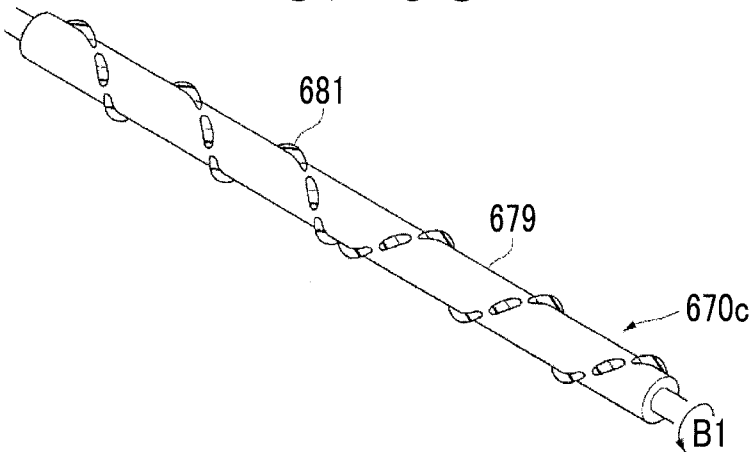

FIG. 15D

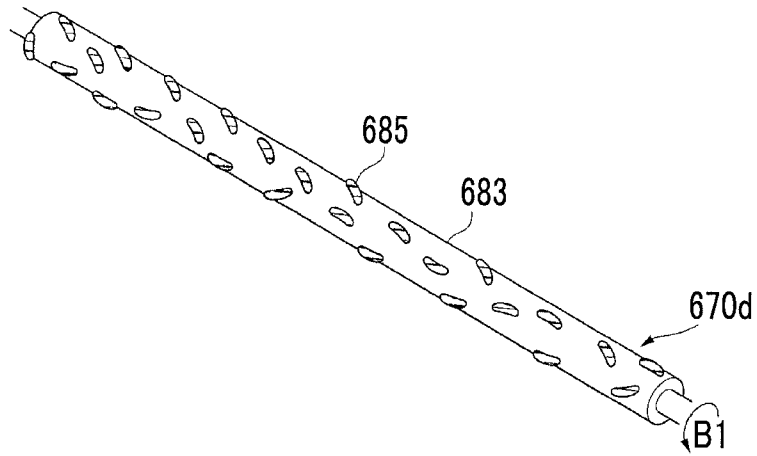

FIG. 15E

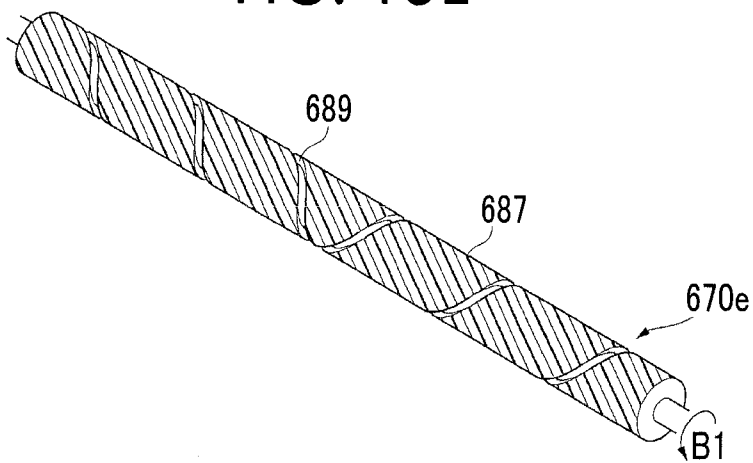

FIG. 15F

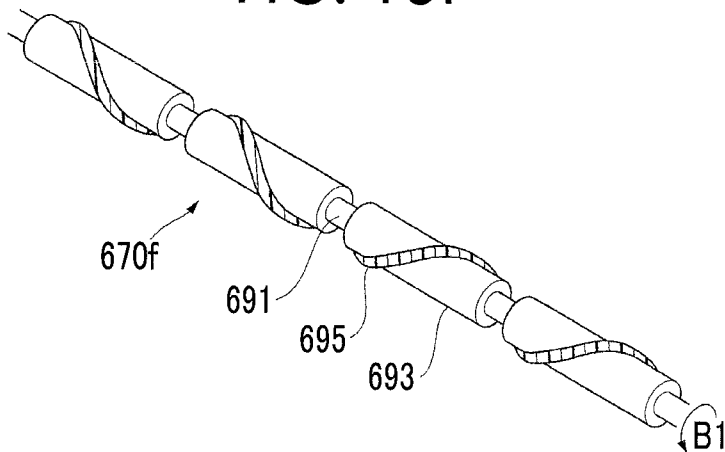

FIG. 16A

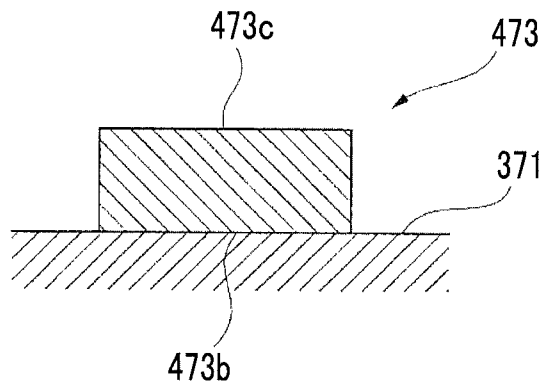
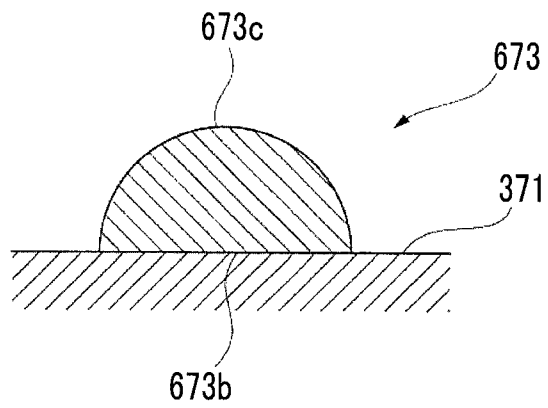

FIG. 16B



1

**SHEET FOLDING DEVICE,
POST-PROCESSING DEVICE, AND IMAGE
FORMING SYSTEM**

CROSS-REFERENCE TO RELATED
APPLICATIONS

This application is based on and claims priority under 35 USC 119 from Japanese Patent Application No. 2013-273449 filed Dec. 27, 2013.

BACKGROUND

Technical Field

The present invention relates to a sheet folding device, a post-processing device, and an image forming system.

SUMMARY

According to an aspect of the invention, there is provided a sheet folding device including:

a folding roll that is rotatably provided and includes a large diameter portion of which a diameter is greater than a diameter of another portion, and performs a folding process while pressing the large diameter portion onto a sheet; and

a contact portion displacement unit that makes a position of a contact portion that is a portion coming into contact with the large diameter portion in the sheet when the sheet on which the folding process has been performed by the folding roll passes through the folding roll again different from a position of the contact portion when the sheet passes through the folding roll for the last time.

BRIEF DESCRIPTION OF THE DRAWINGS

Exemplary embodiments of the present invention will be described in detail based on the following figures, wherein:

FIG. 1 is a view illustrating an entire configuration of an image forming system to which an exemplary embodiment is applied;

FIG. 2 is a view illustrating a function of a post-processing device;

FIG. 3 is a view illustrating a configuration of a saddle stitching bookbinding function portion of the exemplary embodiment;

FIG. 4 is a schematic configuration view of a folding mechanism of the exemplary embodiment;

FIG. 5 is a schematic configuration view of a second folding roll of the exemplary embodiment viewed in a -z direction;

FIGS. 6A to 6C are schematic configuration views of a first spiral roll of the exemplary embodiment;

FIGS. 7A and 7B are schematic configuration views of a drive portion and FIG. 7C is a view illustrating a configuration of a periphery of a third relay gear and a fourth relay gear;

FIG. 8 is a block view of a function of a sheet processing control portion;

FIGS. 9A to 9F are views illustrating an operation of a folding process of the folding mechanism;

FIGS. 10A to 10C are views illustrating a state where the second folding roll sandwiches a sheet bundle;

FIG. 11 is a view illustrating a contact portion with which a first nip portion comes into contact in the sheet bundle;

FIGS. 12A to 12D are views illustrating a change in position of the contact portion as the sheet bundle is reciprocated;

2

FIG. 13 is a schematic configuration view of a second folding roll in another exemplary embodiment 1;

FIG. 14A is a schematic configuration view of a second folding roll in another exemplary embodiment 2 and FIG. 14B is a cross-sectional view taken along line XIVb of FIG. 14A;

FIGS. 15A to 15F are schematic configuration views of a modification example of a first spiral roll; and

FIGS. 16A and 16B are schematic configuration views of a modification example of a first nip portion.

DETAILED DESCRIPTION

Hereinafter, an exemplary embodiment of the invention will be described with reference to the accompanying drawings.

Description of Image Forming System 100

FIG. 1 is a view illustrating an entire configuration of an image forming system 100 to which an exemplary embodiment is applied. For example, the image forming system 100 illustrated in FIG. 1 includes an image forming apparatus 1 such as a printer or a copying machine that forms a color image by an electrophotographic system, and a post-processing device 2 that performs post-processing with respect to a recording material (sheet) S on which an image is formed by the image forming apparatus 1.

The image forming apparatus 1 includes an image forming portion 10 that forms the image based on each piece of color image data, an image reading portion 11 that reads the image from a document and generates read image data, a sheet supply portion 12 that supplies the sheet S to the image forming portion 10, a general user interface 13 that notifies a user of an abnormality in the image forming system 100 in conjunction with receiving an operation input from a user, and a main control portion 14 that controls an entire operation of the image forming system 100.

The post-processing device 2 includes a transport unit 3 that receives and transports the sheet S on which the image is formed from the image forming apparatus 1, a folding unit 4 that performs a folding process with respect to the sheet S carried in from the transport unit 3, a finisher unit 5 that performs a final process with respect to the sheet S that passes through the folding unit 4, and an interposer 6 that supplies a jointed paper for configuring a cover and the like of a booklet. Furthermore, the post-processing device 2 includes a sheet processing control portion 7 that controls each function portion of the post-processing device 2 and a user interface (UI) 15 that receives the operation input from the user regarding the post-processing.

Moreover, in the post-processing device 2 of FIG. 1, the sheet processing control portion 7 is provided inside the post-processing device 2, however the sheet processing control portion 7 may be provided inside the image forming apparatus 1. Furthermore, the main control portion 14 may be configured to have a control function of the sheet processing control portion 7.

Furthermore, in the post-processing device 2 of FIG. 1, the user interface 15 is provided inside the post-processing device 2, however the user interface 15 may be provided inside the image forming apparatus 1. Furthermore, the general user interface 13 of the image forming apparatus 1 may be configured to have a control function of the user interface 15.

Description of Post-Processing Device 2

FIG. 2 is a view illustrating a function of the post-processing device 2. The post-processing device 2 includes a punch function portion 70 that performs drilling (punching) two

holes, four holes, and the like with respect to the sheet S (see FIG. 1) in the finisher unit 5, an end stitching function portion 40 that generates a sheet bundle B (see FIG. 4) only by integrating the required number of the sheets S and performs staple stitching (end stitching) in an end portion of the sheet bundle B, and a saddle stitching bookbinding function portion 30 that generates the sheet bundle B by integrating the required number of the sheets S and performs a stitching process (saddle stitching process) in the center portion of the sheet bundle B and binds a booklet. Furthermore, the folding unit 4 includes a folding function portion 50 that performs inward three-folding (C folding), outward three-folding (Z folding), or the like with respect to the sheet S. Furthermore, the interposer 6 and the transport unit 3 include a jointed paper supply function portion 90 that supplies the jointed paper such as cardboard or a window-space sheet that is used as a cover of the sheet bundle B.

Description of Saddle Stitching Bookbinding Function Portion 30

Next, the saddle stitching bookbinding function portion 30 provided in the finisher unit 5 will be described.

FIG. 3 is a view illustrating a configuration of the saddle stitching bookbinding function portion 30 of the exemplary embodiment.

As illustrated in FIG. 3, the saddle stitching bookbinding function portion 30 includes a compile tray 31 that integrates the sheets S after the image is formed by the predetermined number of sheets and forms the sheet bundle B (see FIG. 4), a carry-in roll 39 that carries the sheets S into the compile tray 31 one by one, and an end guide 32 that stacks the sheet bundle B and determines a saddle stitching position and a folding position of the sheet bundle B. Furthermore, the saddle stitching bookbinding function portion 30 includes a sheet alignment paddle 33 that aligns the sheets S (see FIG. 1) integrated in the compile tray 31 toward the end guide 32 and a sheet width alignment member 34 that aligns the sheets S integrated in the compile tray 31 in a width direction.

Furthermore, the saddle stitching bookbinding function portion 30 includes a stapler 82 that performs stitching of the sheet bundle B integrated in the compile tray 31 while penetrating staples (not illustrated). Furthermore, the saddle stitching bookbinding function portion 30 includes a folding knife 35 having a knife body 35a that moves so as to protrude from a rear surface side of the compile tray 31 toward a storage surface side (z direction) with respect to the sheet bundle B on which a stitching process is performed. Furthermore, the saddle stitching bookbinding function portion 30 includes in order a first folding roll 36 and a second folding roll 37 that perform the folding process in the sheet bundle B in which the folding is started by the folding knife 35 in the sheet transporting direction. Furthermore, a discharge roll 38 that discharges the sheet bundle B that is subjected to the folding process and is bound and a booklet stack tray 45 that stacks the sheet bundles B that are bound are provided on a downstream side of the second folding roll 37. Furthermore, the saddle stitching bookbinding function portion 30 includes a drive portion 81 that transmits a driving force to the folding knife 35, the first folding roll 36, and the second folding roll 37, and a passage sensor 92 that detects passage of the sheet S that is carried into the compile tray 31 by the carry-in roll 39.

Moreover, in the following description, the folding knife 35, the first folding roll 36, the second folding roll 37, and the drive portion 81 are described as a folding mechanism 80.

Furthermore, in FIG. 3, a direction in which the sheet S in the storage surface of the compile tray 31 is carried is referred to as a y direction, a direction (a width direction of the sheet

S) orthogonal to the direction in which the sheet S in the storage surface is carried is referred to as an x direction, and a direction orthogonal to the storage surface of the compile tray 31 is referred to as a z direction. Also, this is the same as in the views illustrated below. Furthermore, in the following description, the z direction is simply referred to a sheet transporting direction and the x direction is simply referred to as an intersecting direction in some cases.

Configuration of Folding Mechanism 80

Next, a configuration of the folding mechanism 80 will be described.

FIG. 4 is a schematic configuration view of the folding mechanism 80 of the exemplary embodiment.

As described above, the folding mechanism 80 includes the folding knife 35, the first folding roll 36, and the second folding roll 37, and simultaneously includes the folding knife 35, the first folding roll 36, and the drive portion 81.

The folding knife 35 includes the knife body 35a that is a plate-shaped member of which a side surface is pressed against the sheet bundle B. The knife body 35a protrudes from the rear surface side of the compile tray 31 toward the storage surface side (+z direction) and retracts in the opposite direction (-z direction) upon receiving the driving force from the drive portion 81.

Moreover, the knife body 35a of the illustrated example is provided so as to be movable to a position in which a leading end thereof passes through between a pair of rolls (a first roll 36a and a second roll 36b, described below) of the first folding roll 36. Furthermore, the knife body 35a is configured such that the leading end thereof retracts in the rear surface direction (-z direction) of the compile tray 31 and does not appear on the surface (storage surface) of the compile tray 31 in a sheet integrating step of the compile tray 31, a saddle stitching step of the stapler 82 (see FIG. 3), or a sheet transport step after the saddle stitching.

The first folding roll 36 includes the first roll 36a and the second roll 36b that are a pair of roll bodies. The first roll 36a and the second roll 36b are rotated forward (see arrow A1 in the view) or rotated backward (see arrow A2 in the view), respectively while receiving the driving force from the drive portion 81.

Configuration of Second Folding Roll 37

Next, a configuration of the second folding roll 37 will be described with reference to FIGS. 4, 5, and 6A to 6C.

FIG. 5 is a schematic configuration view of the second folding roll 37 of the exemplary embodiment viewed in the -z direction. FIGS. 6A to 6C are schematic configuration views of a first spiral roll 37a of the exemplary embodiment. More specifically, FIG. 6A is a perspective view of the first spiral roll 37a, FIG. 6B is a cross-sectional view taken along line VIb-VIb of FIG. 6A, and FIG. 6C is a cross-sectional view taken along line VIc-VIc of FIG. 6A.

First, as illustrated in FIG. 4, the second folding roll 37 includes the first spiral roll 37a and a second spiral roll 37b that are a pair of roll bodies. Then, the first spiral roll 37a and the second spiral roll 37b of the illustrated example are rotated forward (see arrow B1 in the view) by receiving the driving force from the drive portion 81. Meanwhile, the second spiral roll 37b is connected to a drive source (a first motor M1, described below) through a one-way clutch 851a (described below) and the first spiral roll 37a is connected to the second spiral roll 37b through a second gear group 93 (described below). Therefore, both the first spiral roll 37a and the second spiral roll 37b do not receive the driving force from the drive portion 81 in the direction of the reverse rotation (see arrow B2 in the view).

As illustrated in FIG. 5, the first spiral roll 37a has a first rotating shaft 371 in which a small diameter portion 371a is formed on both ends and a first nip portion (convex portion) 373 that is spirally attached to an outer periphery of the first rotating shaft 371. Furthermore, the first spiral roll 37a includes on both ends a first bearing 381 that is provided in the small diameter portion 371a of the first rotating shaft 371, a support member 383 that supports the small diameter portion 371a of the first rotating shaft 371 through the first bearing 381, and a biasing member 385 that biases the support member 383 toward the second roll 36b. Moreover, a detailed configuration of the support member 383 and the biasing member 385 is described below.

The second spiral roll 37b has a second rotating shaft 375 in which a small diameter portion 375a is formed on both ends and a second nip portion (convex portion) 377 that is spirally attached to an outer periphery of the second rotating shaft 375. Furthermore, the second spiral roll 37b includes on both ends a second bearing 387 that is provided in the small diameter portion 375a of the second rotating shaft 375, and a support member 389 that supports the small diameter portion 375a of the second rotating shaft 375 through the second bearing 387. Moreover, the second spiral roll 37b of the illustrated example is supported by the support member 389 and the position thereof is fixed.

A first gear group 83 configuring the drive portion 81 is connected to an end portion of the second spiral roll 37b in the +x direction. Furthermore, the second gear group 93 configuring the drive portion 81 is connected to end portions of the first spiral roll 37a and the second spiral roll 37b in the -x direction, respectively. The driving force is transmitted to the first spiral roll 37a and the second spiral roll 37b through the first gear group 83 and the second gear group 93 (a detailed description is described below).

Here, the first spiral roll 37a is biased by the support member 383 and the biasing member 385 so that a nip region N is formed by the first nip portion 373 of the first spiral roll 37a and the second nip portion 377 of the second spiral roll 37b. Furthermore, plural nip regions N in the illustrated example are formed in the intersecting direction (x direction). The folding process of the sheet bundle B passing through the second folding roll 37 is performed while the sheet bundle B is sandwiched by the first nip portion 373 and the second nip portion 377 in the nip region N.

Furthermore, the first spiral roll 37a is biased by the support member 383 and the biasing member 385 so that the first spiral roll 37a and the second spiral roll 37b may contact and separate with and from each other in accordance with the thickness of the sheet bundle B passing between the first spiral roll 37a and the second spiral roll 37b. In other words, the first spiral roll 37a is retractably provided with respect to the second spiral roll 37b.

Next, the first rotating shaft 371 of the first spiral roll 37a will be described.

As illustrated in FIG. 6A, the first rotating shaft 371 is a substantially cylindrical member in which the small diameter portion 371a is formed on both ends. For example, the first rotating shaft 371 is formed by a metal material such as aluminum or a resin material. Furthermore, as illustrated in FIG. 6B, a notch 371b configured of a plane formed on an outer peripheral surface of the small diameter portion 371a of the first rotating shaft 371 is provided. That is, the first rotating shaft 371 is a columnar member in which a so-called D-cut is made in an end portion. It is possible to fix the first rotating shaft 371 and a fourth relay gear 859 (described

below) in a predetermined phase by forming the notch 371b when fixing the fourth relay gear 859 in the first rotating shaft 371.

The first nip portion 373 will be described with reference to FIG. 6A again. The first nip portion 373 is made of an elastic member such as urethane, which is spirally wound and fixed on the outer peripheral surface of the first rotating shaft 371. The first nip portion 373 is molded as a separate body from the first rotating shaft 371 and then is fixed on the outer peripheral surface of the first rotating shaft 371 using known adhesive (not illustrated), but may be integrally molded with the first rotating shaft 371. Furthermore, a spiral groove (or protrusion) is formed on the outer peripheral surface of the first rotating shaft 371 and the first nip portion 373 may be formed by applying urethane lining in the groove (or the protrusion).

Moreover, a coefficient of friction of the first nip portion 373 is greater than that of the first rotating shaft 371. Therefore, the first spiral roll 37a is configured to have portions in which the coefficients of friction are relatively large and relatively small in the intersecting direction (x direction).

Now, the first nip portion 373 has a symmetrical shape with respect to a center portion of the first rotating shaft 371 in an axial direction (intersecting direction) thereof. In other words, the first nip portion 373 has two spiral members formed on one end side and the other end side of the first rotating shaft 371. Turning directions (directions inclined with respect to the first rotating shaft 371) of the two spiral members are different (opposite) from each other and the two spiral members are connected to each other through a contact point 373a that is positioned in the center portion of the first rotating shaft 371 in the axial direction. The sheet bundle B is suppressed to be moved (deviated) in the intersecting direction (x direction) as the first spiral roll 37a is rotated by the configuration.

Furthermore, as illustrated in FIG. 6C, in a cross section of the first nip portion 373, a width of a base portion 373b fixed on the outer peripheral surface of the first rotating shaft 371 is wider than that of a top portion 373c that is pressed against the sheet bundle B and the cross section thereof is substantially trapezoidal. An area of the top portion 373c in contact with the sheet bundle B is suppressed while securing a contact area between the first nip portion 373 and the first rotating shaft 371 by the configuration. Regarding dimension of the first nip portion 373, for example, the width of the base portion 373b is 10 mm to 30 mm, the width of the top portion 373c is 1 mm to 10 mm, and a height from the outer peripheral surface of the first rotating shaft 371 is 1 mm to 15 mm. Moreover, in the illustrated example, the top portion 373c is a flat surface and the first nip portion 373 is protected from damage due to concentration of a load.

Moreover, even though a detailed description is omitted, as illustrated in FIG. 5, the second rotating shaft 375 of the second spiral roll 37b has the same configuration as that of the first rotating shaft 371 of the first spiral roll 37a except for a difference in lengths in the axial direction. In other words, notches (not illustrated) that are flat surfaces formed on the outer peripheral surface are provided on both ends of the second rotating shaft 375 and it is possible to fix the second rotating shaft 375, a second spiral roll gear 851 (described below), and a first relay gear 853 (described below) in a predetermined phase when fixing the second spiral roll gear 851 and the first relay gear 853 to the second rotating shaft 375.

Furthermore, the second nip portion 377 of the second spiral roll 37b has the same configuration as that of the first nip portion 373 of the first spiral roll 37a except that the turning directions of the spirals are opposite. In other words,

the first nip portion **373** and the second nip portion **377** are configured such that pitches of the spirals are equal to each other. Furthermore, in the illustrated example, the first nip portion **373** and the second nip portion **377** are configured such that other dimensions such as the respective width of the base portion **373b** or the top portion **373c**, or the height from the base portion **373b** to the top portion **373c** are equal to each other.

Configuration of Drive Portion **81**

Next, a configuration of the drive portion **81** will be described.

FIGS. **7A** and **7B** are schematic configuration views of the drive portion **81** and FIG. **7C** is a view illustrating a configuration of a periphery of a third relay gear **857** and the fourth relay gear **859**. More specifically, FIG. **7A** is a schematic configuration view of the first gear group **83** and FIG. **7B** is a schematic configuration view of the second gear group **93**. Furthermore, FIGS. **7A**, **7B**, and **7C** are views of the drive portion **81** and the like viewed in the +x direction.

As illustrated in FIGS. **7A** and **7B**, the drive portion **81** includes the first motor **M1** that is a drive source, the first gear group **83** that is provided on the end portion of the second folding roll **37** (see FIG. **5**) in the +x direction and is rotated by receiving the drive of the first motor **M1**, and the second gear group **93** that is provided on the end portion of the second folding roll **37** in the -x direction and is rotated by receiving the drive of the first gear group **83** through the second spiral roll **37b**.

First, the first motor **M1** is an electric motor capable of rotating forward and rotating backward.

Next, the first gear group **83** will be described with reference to FIGS. **7A** and **7B**.

The first gear group **83** includes a first gear **831** that is rotated by receiving the drive of the first motor **M1**, a second gear **833** and a third gear **835** that transmit the drive from the first gear **831**, and a knife body gear **837** that is provided in the knife body **35a** and is rotated by receiving the drive from the third gear **835**. Furthermore, the first gear group **83** includes a third gear **839**, a fourth gear **841**, and a fifth gear **843** that transmit the drive from the first gear **831**.

Furthermore, the first gear group **83** has a first folding roll gear **845** that is provided in the first roll **36a** of the first folding roll **36** (see FIG. **4**) and is rotated by receiving the drive of the fourth gear **841**, and a second folding roll gear **847** that is provided in the second roll **36b** of the first folding roll **36** and is rotated by receiving the drive of the fifth gear **843**. Furthermore, the first gear group **83** has the second spiral roll gear **851** that is provided in the second spiral roll **37b** of the second folding roll **37** and is rotated by receiving the drive of the fifth gear **843**.

Here, the one-way clutch **851a** is disposed inside the second spiral roll gear **851**. The one-way clutch **851a** transmits the drive to the second spiral roll **37b** when the second spiral roll **37b** receives the rotating forward drive (see arrow **B1** in the view). However, the one-way clutch **851a** idles without transmitting the drive to the second spiral roll **37b** when receiving the rotating backward drive (see arrow **B2** in the view) from the first motor **M1**.

Next, the second gear group **93** will be described with reference to FIG. **7B**.

The second gear group **93** includes the first relay gear **853** that is provided in the second spiral roll **37b** that is rotated by receiving the drive from the first motor **M1**, a second relay gear **855** and the third relay gear **857** that transmit the drive from the first relay gear **853**, and the fourth relay gear **859** that

is provided in the first spiral roll **37a** of the second folding roll **37** and is rotated by receiving the drive from the third relay gear **857**.

Here, the number of teeth of the first relay gear **853** is the same as that of the fourth relay gear **859**. Therefore, the first relay gear **853** and the fourth relay gear **859** that are rotated by receiving the drive from the first motor **M1** that is a drive source common to both are rotated at the same speed. Therefore, the second spiral roll **37b** and the first spiral roll **37a** to which the first relay gear **853** and the fourth relay gear **859** are respectively attached are also rotated at the same speed. As a result, a state where the nip region **N** is formed by the first nip portion **373** and the second nip portion **377** is maintained in any position in the intersecting direction (x direction) in a region where the first spiral roll **37a** and the second spiral roll **37b** face each other regardless of rotation angles (phases) of the first spiral roll **37a** and the second spiral roll **37b**.

Meanwhile, as described above, the first spiral roll **37a** is supported by the support member **383** and the biasing member **385**, and is capable of advancing and retracting with respect to the second spiral roll **37b**. Then, even if the first spiral roll **37a** is advanced and retracted with respect to the second spiral roll **37b**, the fourth relay gear **859** provided in the first spiral roll **37a** maintains a state of being engaged with the third relay gear **857** that transmits the drive to the fourth relay gear **859**. Hereinafter, a configuration in which the engagement between the fourth relay gear **859** and the third relay gear **857** is maintained will be described in detail.

First, as illustrated in FIG. **7C**, the support member **383** is a long plate-shaped member. The support member **383** includes a first opening portion **383a** that is provided on one end, a concave portion **383b** that is provided on the side surface of the other end, and a second opening portion **383c** that is provided between the first opening portion **383a** and the concave portion **383b**, and close to the first opening portion **383a**. Here, a third bearing **391** supporting a rotating shaft **857a** of the third relay gear **857** is fitted inside the first opening portion **383a** of the support member **383**, one end of the biasing member **385** is hung at the concave portion **383b**, and the first rotating shaft **371** of the first spiral roll **37a** is disposed in the second opening portion **383c** through the first bearing **381**. Moreover, as described above, the fourth relay gear **859** is provided in the first rotating shaft **371** of the first spiral roll **37a**.

Here, the rotating shaft **857a** of the third relay gear **857** is supported on, for example, a housing (not illustrated) and the position thereof is fixed. Furthermore, the support member **383** is capable of rotating around the rotating shaft **857a**.

Furthermore, in the illustrated example, the biasing member **385** is a coil spring (elastic member) and is connected to the support member **383** by hanging one end thereof on the concave portion **383b** of the support member **383** as described above.

Meanwhile, the support member **383** receives a force that makes the support member **383** rotate around the rotating shaft **857a** of the third relay gear **857** using the biasing member **385** connected to the concave portion **383b** (see arrow **D** in the view). As a result, the first rotating shaft **371** that is supported by the second opening portion **383c**, that is, the first spiral roll **37a** is biased toward the second spiral roll **37b** (see arrow **E** in the view).

Here, as described above, the support member **383** is rotated around the rotating shaft **857a** of the third relay gear **857**. Therefore, when the first spiral roll **37a** is advanced and retracted with respect to the second spiral roll **37b**, that is, when the support member **383** is rotated, a distance between the first rotating shaft **371** that is supported by the second

opening portion **383c** of the support member **383** and is a rotational center of the fourth relay gear **859**, and the rotating shaft **857a** of the third relay gear **857** is not changed. That is, a distance between the third relay gear **857** and the fourth relay gear **859** is not changed and a state of being engaged with each other is maintained.

Giving further describing, even if the first spiral roll **37a** is advanced and retracted with respect to the second spiral roll **37b**, the fourth relay gear **859** and the first relay gear **853** are maintained in a state of being engaged with each other through the third relay gear **857** and the second relay gear **855**. Therefore, even if the position of the first spiral roll **37a** is changed, a relative position (phase) between the fourth relay gear **859** and the first relay gear **853** is maintained.

Moreover, here, it is described that the first gear group **83** is provided in the end portion of the second folding roll **37** in the +x direction and the second gear group **93** is provided in the end portion in the -x direction, but the invention is not limited to such a configuration. That is, the first gear group **83** may be provided in the end portion of the second folding roll **37** in the -x direction and the second gear group **93** may be provided in the end portion in the +x direction. Otherwise, both of the first gear group **83** and the second gear group **93** may be provided in any one of end portions of the second folding roll **37** in the +x direction and the -x direction.

Sheet Processing Control Portion 7

Next, a function of the sheet processing control portion **7** that controls each function portion of the post-processing device **2** will be described.

FIG. **8** is a block view of the function of the sheet processing control portion **7**.

In the exemplary embodiment, information of the process (folding process) of the sheet bundle **B** that is to be formed from this point is input from the main control portion **14** of the image forming apparatus **1** into the sheet processing control portion **7**. Furthermore, a processing signal for the process (folding process) performed in the sheet bundle **B**, which is received through the user interface (UI) **15**, is input into the sheet processing control portion **7**. Furthermore, a detection signal indicating that the sheet **S** is detected is input from the passage sensor **92** into the sheet processing control portion **7**.

The sheet processing control portion **7** outputs the control signal to the first motor **M1**, based on the signals input from the main control portion **14**, the user interface **15**, and the passage sensor **92**.

Moreover, even though not illustrated, the sheet processing control portion **7** also outputs the control signal to a function portion other than the saddle stitching bookbinding function portion **30** such as the stapler **82**, or to each function portion of the punch function portion **70** and the end stitching function portion **40**.

The sheet processing control portion **7** is configured by including a Central Processing Unit (CPU), a Read Only Memory (ROM), a Random Access Memory (RAM), and a Hard Disk Drive (HDD) (not illustrated). A processing program is executed in the CPU. Various programs, various tables, parameters, and the like are stored in the ROM. The RAM is used as a work area and the like when executing various programs by the CPU.

Operation of the Saddle Stitching Bookbinding Function Portion 30

Next, an operation of the saddle stitching bookbinding function portion **30** will be described.

Here, first, an aspect of a basic operation of the saddle stitching bookbinding function portion **30** is described with reference to FIGS. **3** and **4** and then an operation of the folding

process by the folding mechanism **80** is described in detail with reference to FIGS. **9A** to **9F**.

FIGS. **9A** to **9F** are views illustrating the operation of the folding process of the folding mechanism **80**. Moreover, the description of the folding knife **35** is omitted in FIGS. **9A** to **9F**.

As illustrated in FIG. **3**, when making the booklet, the finisher unit **5** receives the sheet **S** on which the image formation (print) is completed, which is output through a discharge roll **46** of the folding unit **4** in a sheet carry-in port **71**, and the sheet **S** passes through an inlet roll **41** provided in the vicinity of the sheet carry-in port **71**, and then a punching (drilling) process is performed in the punch function portion **70** if necessary. Then, the sheet **S** passing through the punch function portion **70** is distributed to the saddle stitching bookbinding function portion **30**, an upper sheet storage tray (upper sheet stack portion) **49**, or the end stitching function portion **40** by a first gate **42**.

When discharging the sheet **S** on which the image formation is completed to the outside or making an end stitched booklet, the sheet **S** is directed upward in the first gate **42** and is transported further upward by a transport roll **43**, based on the control signal from the sheet processing control portion **7**, and is transported to the upper sheet storage tray **49** or the end stitching function portion **40**. Meanwhile, when making a saddle stitched booklet, the sheet **S** is directed downward in the first gate **42**, based on the control signal from the sheet processing control portion **7** and is transported to the carry-in roll **39** through a transport roll **44**.

The carry-in roll **39** stacks the transported sheets **S** on the compile tray **31** in order to integrate the sheets **S** in the compile tray **31**. For example, the number of sheets that are set in the main control portion **14** (see FIG. **1**) of the image forming apparatus **1**, for example five sheets, and ten sheets are integrated in the compile tray **31**.

At this time, the passage sensor **92** outputs the detection signal to the sheet processing control portion **7** whenever each of the sheets **S** is transported by the carry-in roll **39**. Furthermore, the sheet alignment paddle **33** rotates toward the end guide **32** and presses the integrated sheets **S** against the end guide **32** and then assists in the sheet alignment. Furthermore, the sheet width alignment member **34** slidingly moves in the width direction of the sheets **S** integrated in the compile tray **31** whenever each of the sheets **S** is transported and performs the sheet alignment with respect to the integrated sheets **S** in the width direction.

Then, the predetermined number of the sheets **S** are integrated and the sheet bundle **B** is formed on the compile tray **31**. Then, the staples (not illustrated) are disposed by the stapler **82** with respect to the sheet bundle **B** and the stitching process is performed.

Then, the end guide **32** moves to the upstream side (y direction) of the sheet **S** in the storage surface of the compile tray **31** and a portion (center portion in the sheet transporting direction) in which the staples (not illustrated) of the sheet bundle **B** are disposed is a position facing the leading end of the knife body **35a**. When the sheet bundle **B** reaches the position, the knife body **35a** of the folding mechanism **80** is extruded from the rear surface side of the compile tray **31** toward the storage surface side (z direction) and performs the folding process in the sheet bundle **B** while passing through the first folding roll **36** and the second folding roll **37**. Then, the sheet bundle **B** in which the folding process is performed is discharged by the discharge roll **38** and is stacked on the booklet stack tray **45**.

11

Folding Processing Operation of Folding Mechanism 80

A folding processing operation by the folding mechanism 80 will be described with reference to FIGS. 9A to 9F.

First, as illustrated in FIG. 9A, the sheet bundle B against which the knife body 35a (see FIG. 4) of the folding knife 35 abuts is transported while being sandwiched by the first folding roll 36 and the second folding roll 37, respectively. At this time, the first folding roll 36 and the second folding roll 37 receiving the drive of the first motor M1 that is rotated forward are rotated forward (see arrows A1 and B1 in the view). Here, in the illustrated example, when a leading end (folding stripe) Bp of the sheet bundle B reaches the space between the first spiral roll 37a and the second spiral roll 37b in the second folding roll 37, the first spiral roll 37a and the second spiral roll 37b are in a rotation angle (phase) in which the first nip portion 373 and the second nip portion 377 sandwich the leading end Bp. Moreover, a position on the sheet transport path in which the first spiral roll 37a and the second spiral roll 37b are closest to each other is referred to as a reference position P0.

Then, as illustrated in FIG. 9B, when the leading end Bp of the sheet bundle B passes through the reference position P0 and reaches a first position P1 that is a position on the sheet transport path, the first folding roll 36 and the second folding roll 37 are stopped.

Next, as illustrated in FIG. 9C, the first folding roll 36 is rotated backward (see arrow A2 in the view) by receiving the drive of the first motor M1 that is rotated backward. As a result, the sheet bundle B is pulled back toward the folding knife 35 (see FIG. 4) side. At this time, the second folding roll 37 in which the one-way clutch 851a (see FIG. 5) is provided is rotated backward (see arrow B2 in the view) while idling. That is, as described above, the second folding roll 37 does not receive the drive from the first motor M1 that is rotated backward. Meanwhile, the sheet bundle B that is pulled back as the first folding roll 36 is rotated backward, and the second folding roll 37 come into contact with each other. Therefore, the second folding roll 37 rotates (idles) so as to be dragged by the sheet bundle B.

Then, as illustrated in FIG. 9D, when the first motor M1 continuously rotates backward, the sheet bundle B is continuously pulled back by the first folding roll 36 and the sheet bundle B is separated from the second folding roll 37 at a predetermined time. Then, the second folding roll 37 to which the drive from the first motor M1 is not transmitted stops the rotation thereof when the sheet bundle B is separated. Thereafter, in a state where the second folding roll 37 is stopped, the sheet bundle B is moved by the first folding roll 36 and then the phases of the sheet bundle B and the second folding roll 37 deviate (change).

Then, as illustrated in FIG. 9E, when the leading end Bp of the sheet bundle B reaches a second position P2 that is a predetermined position on the sheet transport path, the first folding roll 36 is stopped.

Next, as illustrated in FIG. 9F, the first motor M1 rotates forward again and the first folding roll 36 and the second folding roll 37 that receive the drive of the first motor M1 are rotated forward (see arrows A1 and B1 in the view). Then, the leading end Bp of the sheet bundle B reaches between the first spiral roll 37a and the second spiral roll 37b in a phase different from the phase illustrated in FIG. 9A.

As described above, in the exemplary embodiment, the folding process is performed while the leading end Bp of the sheet bundle B passes through the second folding roll 37 plural times and, specifically, while the leading end Bp of the sheet bundle B passes through the reference position P0 plural times, by reciprocating the sheet bundle B by the first folding

12

roll 36. For example, the folding process is performed while the leading end Bp of the sheet bundle B passes through the reference position P0 two times to thirty times in a direction from the first folding roll 36 to the second folding roll 37. Moreover, the number of passages is determined, for example in advance, by storing the number of passages in the ROM (not illustrated) of the sheet processing control portion 7 or by receiving the designation from the user through the user interface 15.

Moreover, in the exemplary embodiment, as illustrated in FIG. 9D described above, in a state where the second folding roll 37 is stopped, the phases of the sheet bundle B and the second folding roll 37 are changed while moving the sheet bundle B and a change amount of the phase may be adjusted by changing a distance in which the sheet bundle B is moved, that is, a distance between the reference position P0 and the second position P2. Moreover, if the distance between the reference position P0 and the second position P2 is large, productivity is reduced and if the distance is small, there is a concern that the second folding roll 37 and the sheet bundle B may not separate from each other and the phase may not change.

In the illustrated example, the second position P2 is positioned between the first folding roll 36 and the second folding roll 37 in the sheet transporting direction.

Moreover, the sheet processing control portion 7 switches between the rotation and the stoppage of the first folding roll 36 and the second folding roll 37, for example, based on a time elapsed from when the detection signal from the passage sensor 92 is received by the sheet processing control portion 7. However, for example, another passage sensor (not illustrated) that detects the sheet bundle B passing through the first position P1 and the second position P2 may be provided and the sheet processing control portion 7 may control the rotation of the first folding roll 36 and the second folding roll 37 by the detection signal from the another passage sensor.

State of Sheet Bundle B

Next, a state where the second folding roll 37 sandwiches the sheet bundle B will be described.

FIGS. 10A to 10C are views illustrating a state where the second folding roll 37 sandwiches the sheet bundle B. More specifically, FIG. 10A illustrates a state where the second folding roll 37 of the exemplary embodiment sandwiches the sheet bundle B, FIG. 10B illustrates a state where a roll pair 370 different from the exemplary embodiment sandwiches the sheet bundle B, and FIG. 10C illustrates a state where a second folding roll 380 in a modification example of the exemplary embodiment sandwiches the sheet bundle B.

As illustrated in FIG. 10A, the second folding roll 37 of the exemplary embodiment performs the folding process while squeezing a part of the sheet bundle B in the width direction (intersecting direction) by sandwiching the sheet bundle B between the first nip portion 373 and the second nip portion 377 in plural portions (the nip region N) in the intersecting direction (x direction). As described above, the first nip portion 373 and the second nip portion 377 squeeze a part of the sheet bundle B in the width direction (intersecting direction) so that, a load for pressing together the first spiral roll 37a and the second spiral roll 37b to perform the folding process in the sheet bundle B is suppressed.

For example, as a comparative example different from the exemplary embodiment, as illustrated in FIG. 10B, a case may be considered in which the sheet bundle B is sandwiched by the roll pair 370 including a first columnar roll 370a and a second columnar roll 370b that are rubber rolls in which rubber (elastic member) is wound around outer peripheral surfaces of columnar metal members respectively. The first

columnar roll **370a** and the second columnar roll **370b** press the sheet bundle B throughout an entire sheet bundle B in the width direction (intersecting direction). Meanwhile, as illustrated in FIG. **10A**, in the exemplary embodiment, a part of the sheet bundle B is pressed in the width direction (intersecting direction) of the sheet bundle B. That is, as illustrated in FIG. **10A**, in the exemplary embodiment, an area of the portion (the nip region N) pressing the sheet bundle B is smaller than that of the configuration illustrated in FIG. **10B**.

Therefore, the load (nip pressure) that is necessary when squeezing (buckling) the portion of the sheet bundle B that is pressed to the same thickness **L1** is smaller in the exemplary embodiment. The first spiral roll **37a** and the second spiral roll **37b** are suppressed from bending due to the small load when applying the load on both the ends of the first spiral roll **37a** and the second spiral roll **37b**. When further describing, for example, the first spiral roll **37a** and the second spiral roll **37b** are suppressed from entering a state of being separated from each other in the center portion in the intersecting direction.

Moreover, as illustrated in FIG. **10C**, as the modification example of the second folding roll **37** of the exemplary embodiment, one side of the second folding roll **380** may be the first spiral roll **37a** and the other side may be a third columnar roll **380b** that is a rubber roll in which the rubber (elastic member) is wound around the outer peripheral surface of the columnar metal member. That is, a spiral member (the first nip portion **373** in the illustrated example) may be provided on the outer peripheral surface of one side rolls in the second folding roll **380**. In the configuration, the load that is applied to the first spiral roll **37a** and the third columnar roll **380b** to press the sheet bundle B is suppressed compared to the roll pair **370** illustrated in FIG. **10B**.

Here, when comparing the configuration illustrated in FIG. **10A** and the configuration illustrated in FIG. **10C**, the applied load is more suppressed in the configuration illustrated in FIG. **10A**. When further describing, in the configuration illustrated in FIG. **10A**, both surfaces of the sheet bundle B are pressed by the first nip portion **373** and the second nip portion **377**, that is, deformation is formed on both surfaces of the sheet bundle B. Meanwhile, in the configuration illustrated in FIG. **10C**, only one surface (upper surface in the view) of the sheet bundle B is pressed by the first nip portion **373** and the deformation is formed on only one surface of the sheet bundle B (deformation is concentrated on one side). Therefore, in the configuration illustrated in FIG. **10A** and the configuration illustrated in FIG. **10C**, when quizzing the sheet bundle B to the same thickness **L1**, the load is smaller in the configuration illustrated in FIG. **10A**. Moreover, a depth **L2** of the deformation on one side formed in the configuration illustrated in FIG. **10A** is smaller than a depth **L3** of the deformation formed in the configuration illustrated in FIG. **10C**.

Next, a positional relationship between the sheet bundle B on which the folding process is performed and the first nip portion **373** will be described.

FIG. **11** is a view illustrating a contact portion Bd with which the first nip portion **373** comes into contact in the sheet bundle B.

As illustrated in FIG. **11**, when the sheet bundle B passes through the second folding roll **37** a single time in the +z direction, if a portion with which the first nip portion **373** comes into contact in the sheet bundle B is referred to as the contact portion Bd, the contact portion Bd is formed by extending in a direction inclined with respect to the sheet transporting direction (z direction). Furthermore, the contact portion Bd has a symmetrical shape (reversed in a mirror) with respect to a center portion in the intersecting direction (x

direction) and a distance **L5** between the contact portion Bd on one side (+x direction) and the contact portion Bd of the other side (-x direction) is formed to be wider going toward the -z direction based on the center portion thereof. In other words, the first nip portion **373** of the second folding roll **37** is configured such that the bending of the sheet bundle B generated by pressing the sheet bundle B is transferred to both of the end sides in the intersecting direction (x direction) as the sheet bundle B is transported in the +z direction (see arrow G). Therefore, the sheet bundle B is suppressed from incurring wrinkles as the second folding roll **37** presses the sheet bundle B. In other words, in the illustrated example, since the coefficient of friction of the first rotating shaft **371** is smaller than that of the first nip portion **373**, the movement of the bending of the sheet bundle B is suppressed from being hindered when the bending of the sheet bundle B is transferred to both of the end sides in the intersecting direction (x direction).

Next, change in the position of the contact portion Bd as the sheet bundle B is reciprocated will be described.

FIGS. **12A** to **12D** are views illustrating the change in the position of the contact portion Bd as the sheet bundle B is reciprocated. More specifically, FIG. **12A** illustrates the position of the contact portion Bd when passing through the second folding roll **37** in the +z direction a first time, FIG. **12B** illustrates the position of the contact portion Bd when passing through the second folding roll **37** in the +z direction a second time, and FIG. **12C** illustrates the position of the contact portion Bd when passing through the second folding roll **37** in the +z direction a third time. FIG. **12D** illustrates the contact portion Bd formed in the sheet bundle B, as a result of the operation illustrated in FIGS. **12A** to **12C**.

First, as illustrated in FIGS. **12A** to **12C**, the positions of the contact portion Bd formed on both the surfaces of the sheet bundle B are positions (the same position) corresponding to each other in the intersecting direction (x direction). Furthermore, when the sheet bundle B passes through the second folding roll **37** plural times by reciprocating the sheet bundle B, the position of the contact portion Bd formed in the sheet bundle B is changed. In the illustrated example, the position of the contact portion Bd in the intersecting direction (x direction) is deviated whenever passing through the second folding roll **37**.

Furthermore, as illustrated in FIG. **12D**, also in the leading end Bp of the sheet bundle B, the position of the contact portion Bd formed by the first nip portion **373** (and the second nip portion **377**) is moved whenever passing through the second folding roll **37**. That is, the positions of the contact portion Bd (see the contact portion Bd indicated in a solid line in the view) when passing through the second folding roll **37**, the first time, the contact portion Bd (see the contact portion Bd indicated in a broken line in the view) when passing through the second folding roll **37**, the second time, and the contact portion Bd (see the contact portion Bd indicated in a dash-dotted line in the view) when passing through the second folding roll **37**, the third time are deviated from each other. Therefore, the folding process in the leading end Bp of the sheet bundle B is further favorably performed. When further describing, the sheet bundle B is suppressed from bulging.

As illustrated in FIG. **9E** described above, the phases of the sheet bundle B and the second folding roll **37** may be deviated by separating the second folding roll **37** from the sheet bundle B, when reciprocating the sheet bundle B.

Therefore, it may be understood that the first gear group **83** and the second gear group **93** (see FIGS. **7A** and **7B**) are configured such that the phases of the sheet bundle B and the second folding roll **37** are deviated when the sheet bundle B

15

and the second folding roll **37** are separated from each other. When further describing, that the first gear group **83** and the second gear group **93** are configured such that the position at which the contact portion **Bd** is formed in the sheet bundle **B** is moved when reciprocating the sheet bundle **B** in the region across the second folding roll **37** in the sheet transporting direction may be understood. In other words, the first gear group **83** and the second gear group **93** are configured such that the sheet bundle **B** is gradually folded by transferring the sheet bundle **B** to and from the second folding roll **37** plural times.

Meanwhile, as described above, the dimension of the apparatus are small, for example, compared to a configuration in which plural rolls are provided along the sheet transporting direction different from that in the exemplary embodiment by reciprocating the sheet bundle **B** and by repeating the folding process plural times by the second folding roll **37**.

Furthermore, for example, it is possible to realize the exemplary embodiment by replacing a transport roll (not illustrated) provided in the post-processing device (not illustrated) of the related art different from that in the exemplary embodiment by the second folding roll **37** described above, and by changing the settings of a control portion (not illustrated) provided in the post-processing device of the related art. In other words, it is sufficient by changing only the settings of the control portion and, for example, exchanging a substrate (not illustrated) and the like which is a member configuring the control portion is not necessary in principle.

Other Exemplary Embodiment 1

Other exemplary embodiment 1 is described.

FIG. **13** is a schematic configuration view of a second folding roll **470** in the other exemplary embodiment 1.

Moreover, in the following description, the same symbol as FIG. **5** is given to the same function member as the second folding roll **37** illustrated in FIG. **5** described above and detailed description thereof will be omitted.

The second folding roll **470** includes a moving mechanism **91** that moves the first spiral roll **37a** and the second spiral roll **37b** in the intersecting direction (*x* direction).

The moving mechanism **91** includes a base member **911** that supports the first spiral roll **37a** and the second spiral roll **37b**, a rack gear **913** that is provided in the base member **911**, a pinion gear **915** that is engaged with the rack gear **913**, and a second motor **M2** that supplies a driving force to the pinion gear **915**.

Then, the moving mechanism **91** may move the first spiral roll **37a** and the second spiral roll **37b** as the base member **911** is moved in the intersecting direction (*x* direction) by receiving the drive of the second motor **M2**. In the illustrated example, in the moving mechanism **91**, the first spiral roll **37a** and the second spiral roll **37b** are capable of being disposed in four portions (**S1** to **S4**) with a gap smaller than a distance (pitch) **L7** between spirals adjacent to each other in the first nip portion **373** (or the second nip portion **377**).

The moving mechanism **91** moves (offsets) the first spiral roll **37a** and the second spiral roll **37b** in the intersecting direction (*x* direction) while maintaining a state where the first spiral roll **37a** and the second spiral roll **37b** face each other in the period illustrated in FIG. **9D** described above, that is, when the sheet bundle **B** is pulled back by the first folding roll **36** and the sheet bundle **B** is separated from the second folding roll **470**. Specifically, for example, the first spiral roll **37a** and the second spiral roll **37b** are moved from a position **S1** to a position **S2** in synchronization. Therefore, when the sheet bundle **B** passes through the second folding roll **470**

16

again, the position of the contact portion **Bd** formed in the sheet bundle **B** is moved. Furthermore, a state where the contact portion **Bd** formed on one surface of the sheet bundle **B** is positioned in the same position as the contact portion **Bd** formed on the other surface in the intersecting direction (*x* direction) is maintained.

Moreover, a driving period of the moving mechanism **91** is determined by the sheet processing control portion **7**, for example, based on time elapsed from when the detection signal from the passage sensor **92** (see FIG. **3**) is received by the sheet processing control portion **7** (see FIG. **3**). However, for example, another passage sensor (not illustrated) that detects the sheet bundle **B** passing through the first position **P1** and the second position **P2** (see FIG. **9E**) may be provided and the sheet processing control portion **7** may control the moving mechanism **91** with the detection signal from the another passage sensor.

Furthermore, in the exemplary embodiment, it is possible to suppress an amount (distance) of the sheet bundle **B** from being pulled back, for example, by the first folding roll **36** compared to the exemplary embodiment described using FIG. **5** and the like.

Other Exemplary Embodiment 2

Next, other exemplary embodiment 2 will be described.

FIG. **14A** is a schematic configuration view of a second folding roll **570** in other exemplary embodiment 2 and FIG. **14B** is a cross-sectional view taken along line **XIVb-XIVb** of FIG. **14A**.

Moreover, in the following description, the same symbol is given to the same function member as the second folding roll **37** illustrated in FIG. **5** or the second folding roll **470** illustrated in FIG. **13** described above and detailed description thereof will be omitted.

First, it is described that the first nip portion **373** and the second nip portion **377** spirally attached to the outer periphery of the first rotating shaft **371** and the second rotating shaft **375**, respectively, are provided in the second folding roll **37** illustrated in FIG. **5** described above.

Meanwhile, the second folding roll **570** illustrated in FIG. **14A** includes a first different diameter roll **570a** and a second different diameter roll **570b**. Then, the first different diameter roll **570a** includes a first rotating shaft **571** and a first large diameter portion **573** which is provided on an outer periphery of the first rotating shaft **571** and of which an outer diameter is greater than that of the first rotating shaft **571**. Furthermore, the second different diameter roll **570b** includes a second rotating shaft **575** and a second large diameter portion **577** which is provided on the outer periphery of the second rotating shaft **575**, and of which an outer diameter is greater than that of the second rotating shaft **575**. The first large diameter portion **573** and the second large diameter portion **577** are provided in positions (same position) corresponding to each other in the intersecting direction (*x* direction) and are provided as plural numbers with the predetermined gap (distance **L9**) in the illustrated example. Moreover, it may be understood that the first different diameter roll **570a** and the second different diameter roll **570b** are configured to include plural rolls of small width, respectively.

Furthermore, it is described that the second spiral roll gear **851** including the one-way clutch **851a** is provided in the second folding roll **37** illustrated in FIG. **5** described above.

Meanwhile, a first drive gear **949** and a second drive gear **951** capable of transmitting a driving force for forward rotation and backward rotation to the first different diameter roll **570a** and the second different diameter roll **570b** are provided

in the second folding roll **570** illustrated in FIG. **14A**. Then, the second folding roll **570** is rotated forward and rotated backward by receiving the driving force from the first motor **M1** through the first drive gear **949** and the second drive gear **951**.

Here, the first large diameter portion **573** and the second large diameter portion **577** are formed of an elastic member such as urethane. Furthermore, as illustrated in FIG. **14B**, in the first large diameter portion **573**, a width of a base member **573b** fixed to an outer peripheral surface of the first rotating shaft **571** is wider than that of a top portion **573c** that is pressed against the sheet bundle **B**. Therefore, the first large diameter portion **573** is configured such that an area of the top portion **573c** coming into contact with the sheet bundle **B** is suppressed while securing a contact area with the first rotating shaft **571**.

Furthermore, the moving mechanism **91** may move the first different diameter roll **570a** and the second different diameter roll **570b** in the intersecting direction (x direction). In the illustrated example, in the moving mechanism **91**, the first different diameter roll **570a** and the second different diameter roll **570b** may be disposed in four portions (S1 to S4) with gaps smaller than a distance (pitch) **L9** between the first large diameter portions **573** (or the second large diameter portions **577**) adjacent to each other.

Furthermore, the moving mechanism **91** moves the first different diameter roll **570a** and the second different diameter roll **570b** in the intersecting direction (x direction) while maintaining a state where the first large diameter portion **573** and the second large diameter portion **577** face each other in the period illustrated in FIG. **9D** described above, that is, when the sheet bundle **B** is pulled back by the first folding roll **36** and the sheet bundle **B** is separated from the second folding roll **570**. Specifically, for example, the first different diameter roll **570a** and the second different diameter roll **570b** are moved from the position **S1** to the position **S2**. Therefore, when the sheet bundle **B** passes through the second folding roll **570** again, the position of the contact portion **Bd** formed in the sheet bundle **B** is moved. Furthermore, a state where the contact portion **Bd** formed on one surface of the sheet bundle **B** is positioned in the same position as the contact portion **Bd** formed on the other surface in the intersecting direction (x direction) is maintained.

The first large diameter portion **573** and the second large diameter portion **577** are different from the first nip portion **373** and the second nip portion **377** (see FIG. **5**), and a position of a portion contacting the sheet bundle **B** in the intersecting direction (x direction) is not moved as the first rotating shaft **571** and the second rotating shaft **575** are rotated. In other words, in principle, a force from the sheet bundle **B** in the intersecting direction (x direction) is not received. Therefore, the first large diameter portion **573** and the second large diameter portion **577** are protected from being peeled from the first rotating shaft **571** and the second rotating shaft **575**.

Moreover, differently from the above description, for example, a contacting-separating mechanism (not illustrated) that brings into contact and separates one of the first different diameter roll **570a** and the second different diameter roll **570b** with and from the other is provided and the moving mechanism **91** may move the first different diameter roll **570a** and the second different diameter roll **570b** in the intersecting direction (x direction), when the contacting-separating mechanism separates the first different diameter roll **570a** and the second different diameter roll **570b** from each other.

In other words, in the configuration, the sheet bundle **B** may be pulled back by the first folding roll **36** or may not be pulled back by the first folding roll **36**. In the latter case, by the

contacting-separating mechanism, the first different diameter roll **570a** and the second different diameter roll **570b** are separated while stopping the sheet bundle **B**, and then the first different diameter roll **570a** and the second different diameter roll **570b** are moved in the intersecting direction (x direction) by the moving mechanism **91**, and the first different diameter roll **570a** and the second different diameter roll **570b** approach each other again. Therefore, the position of the contact portion **Bd** formed in the sheet bundle **B** is moved without moving the sheet bundle **B**.

Furthermore, it is not essential that the first different diameter roll **570a** and the second different diameter roll **570b** include plural first large diameter portions **573** and second large diameter portions **577**, and may include one, respectively.

Otherwise, it is not essential that the first large diameter portions **573** and the second large diameter portions **577** be provided at a predetermined gap (distance **L9**), and for example, may be formed in a different pitch, for example, the center portion may be densely provided than the end portion in the intersecting direction (x direction).

Furthermore, one of the first different diameter roll **570a** and the second different diameter roll **570b** may be configured of a roll (not illustrated) of which an outer diameter does not change along the intersecting direction (x direction), that is, may be formed of a substantially columnar roll.

Modification Example

Next, a modification example of each exemplary embodiment described above will be described.

FIGS. **15A** to **15F** are schematic configuration views of the modification example of the first spiral roll **37a**. FIGS. **16A** and **16B** are schematic configuration views of the modification example of the first nip portion **373**.

In the description regarding FIG. **5** described above, it is described that the first spiral roll **37a** (and the second spiral roll **37b**) is provided with the first nip portion **373** spirally attached to the outer periphery of the first rotating shaft **371**. However, the first spiral roll **37a** (and the second spiral roll **37b**) is not limited to such a configuration and the first nip portion **373** may press a part of the sheet bundle **B** in the intersecting direction (x direction) and the position of the contact portion **Bd** in the sheet bundle **B** may be changed in the intersecting direction (x direction) as the rotation angle (phase) in the first rotating shaft **371** is changed.

For example, as a first spiral roll **670a** illustrated in FIG. **15A**, a first rotating shaft **671** and a spiral first nip portion **673** that is wound in one direction on an outer periphery of the first rotating shaft **671** may be configured.

Furthermore, as a first spiral roll **670b** illustrated in FIG. **15B**, a first rotating shaft **675** and plural first nip portions **677** that are V-shaped members provided on an outer periphery of the first rotating shaft **675** may be configured in the intersecting direction (x direction). The V-shaped first nip portion **677** is moved so that a closed end portion **677a** in the V-shape on the first nip portion **677** is the leading end as the first nip portion **677** is rotated forward (see arrow **B1** in the view).

Furthermore, as a first spiral roll **670c** illustrated in FIG. **15C**, plural protrusion portions **681** which are discontinuously formed along two spirals having different directions from each other with respect to a center portion of a first rotating shaft **679** in the axial direction may be configured on the outer peripheral surface of the first rotating shaft **679**.

Furthermore, as a first spiral roll **670d** illustrated in FIG. **15D**, a first rotating shaft **683** and plural protrusion portions

685 of which positions are irregularly formed on an outer periphery of the first rotating shaft 683 may be configured.

Otherwise, as a first spiral roll 670e illustrated in FIG. 15E, a first rotating shaft 687 and a spiral groove 689 formed on an outer periphery of the first rotating shaft 687 may be configured.

Furthermore, as a first spiral roll 670f illustrated in FIG. 15F, a first rotating shaft 691, plural large diameter portions 693 provided on an outer periphery of the first rotating shaft 691, and a first nip portion 695 spirally provided on an outer periphery of the large diameter portion 693 may be configured. Moreover, in the first spiral roll 670f, a space (groove) for inserting the leading end of the knife body 35a (see FIG. 4) is formed between the large diameter portions 693 in the intersecting direction (x direction), and for example, the first spiral roll 670f may be provided instead of the first folding roll 36 (see FIG. 4).

Furthermore, it is described that the first nip portion 373 illustrated in FIG. 6C described above has a substantially trapezoidal cross section, but the invention is not limited to such a configuration. For example, as illustrated in FIG. 16A, a cross section of a first nip portion 473 may be a substantially rectangular shape in which widths of a base portion 473b and a top portion 473c are substantially the same as each other. Otherwise, as illustrated in FIG. 16B, the first nip portion 673 may have a cross section of a substantially semi-circular shape (bowl shape) in which a base portion 673b is a flat surface and a top portion 673c is a curved convex surface.

Moreover, the configuration described with reference to FIGS. 15A to 15F, and FIGS. 16A and 16B described above is related to the first spiral roll 37a, but the same configuration may be applied to the second spiral roll 37b.

Meanwhile, in the above exemplary embodiments, it is described that the position of the contact portion Bd in the sheet bundle B is changed by changing the rotation angle of the second folding roll 37 or the position in the intersecting direction (x direction). Meanwhile, the position of the contact portion Bd in the sheet bundle B may be changed by moving the sheet bundle B in the intersecting direction (x direction) instead of adjusting the rotation angle or the position of the second folding roll 37 or in addition to the adjustment thereof. When further describing, the pulled back sheet bundle B may be moved in the intersecting direction (x direction) after the period illustrated in FIG. 9D described above, that is, after the sheet bundle B is pulled back by the first folding roll 36 and the sheet bundle B is separated from the second folding roll 37. The sheet bundle B may be moved in the intersecting direction (x direction), for example, by driving the first folding roll 36 that pulls back the sheet bundle B by a drive source (not illustrated) which is different from the first motor M1 and the movement of the sheet bundle B is realized by moving the first folding roll 36 by the drive source when the first folding roll 36 pulls back the sheet bundle B.

Otherwise, the first folding roll 36 and the second folding roll 37 may be configured to be separately driven differently from the above description with reference to FIGS. 7A and 7B. In the configuration, for example, when the sheet bundle B is pulled back, the first folding roll 36 and the second folding roll 37 are driven and the sheet bundle B is separated from the second folding roll 37, and then the phases of the first folding roll 36 and the second folding roll 37 are deviated, and, for example, the rotation of the second folding roll 37 may be stopped while the first folding roll 36 continues the rotation in the direction in which the first folding roll 36 pulls back the sheet bundle B. Alternatively, for example, after the

sheet bundle B is separated from the second folding roll 37, the first folding roll 36 is stopped and the second folding roll 37 may be rotated.

Alternatively, the sheet bundle B may be configured not to be reciprocated and a branch path that is branched from the sheet transport path on the downstream side from the second folding roll 37 and is connected to the sheet transport path on the upstream side from the second folding roll 37 may be formed differently from the above description with reference to FIGS. 9A to 9F. Then, the folding process may be performed by transporting one sheet bundle B to the second folding roll 37 through the branch path plural times. Moreover, as described above, in the configuration in which the sheet bundle B is reciprocated, since the branch path is not necessary, dimensions necessary for transporting the sheet bundle B on the upstream side from the second folding roll 37 are suppressed.

Furthermore, the above exemplary embodiments may be applied to the folding function portion 50 (see FIG. 2) that performs the folding of inwardly three-folding (C folding), outwardly three-folding (Z folding), or the like with respect to the sheet S. Furthermore, the second folding roll 37 may be provided instead of the first folding roll 36 or the discharge roll 38 illustrated in FIG. 3. When further describing, in the above exemplary embodiments, it is described that the folding process is performed in the sheet bundle B, but the folding process may be performed in one sheet S.

Moreover, the configuration in which the stitching process is performed in the sheet bundle B by the stapler 82 is not essential and the above exemplary embodiments may be applied to the sheet bundle B in which the stitching process is not performed by the stapler 82.

Moreover, the second folding roll 570 and the moving mechanism 91 are an example of the sheet folding device.

The contact portion Bd is an example of the contact portion and the moving mechanism 91 is an example of a contact portion displacement unit.

The first folding roll 36 is an example of the transport portion.

The first different diameter roll 570a is an example of the first roll and the second different diameter roll 570b is an example of the second roll.

The compile tray 31 is an example of the stack portion.

The image forming portion 10 is an example of the image forming unit.

The foregoing description of the exemplary embodiments of the present invention has been provided for the purposes of illustration and description. It is not intended to be exhaustive or to limit the invention to the precise forms disclosed. Obviously, many modifications and variations will be apparent to practitioners skilled in the art. The embodiments were chosen and described in order to best explain the principles of the invention and its practical applications, thereby enabling others skilled in the art to understand the invention for various embodiments and with the various modifications as are suited to the particular use contemplated. It is intended that the scope of the invention be defined by the following claims and their equivalents.

What is claimed is:

1. A sheet folding device comprising:

a folding roll that is rotatably provided and includes a large diameter portion and a small diameter portion, the large diameter portion having a diameter that is greater than a diameter of the small diameter portion, and the folding roller performing a folding process while pressing the large diameter portion onto a sheet; and

21

a contact portion displacement unit that moves the folding roll from a first position to a second position in an axial direction of the folding roll, and makes a position of a contact portion that is a portion of the sheet coming into contact with the large diameter portion when the sheet on which the folding process has been performed by the folding roll passes through the folding roll at the second position different from a position of the contact portion when the sheet passes through the folding roll at the first position,

wherein the folding roll includes

- a first roll that includes a plurality of first large diameter portions of which diameters are greater than diameters of the another portions; and
- a second roll that is provided along the first roll and includes a plurality of second large diameter portions of which diameters are greater than diameters of the another portions in positions facing the first large diameter portions, respectively, and

wherein the contact portion displacement unit moves the first roll and the second roll together in a direction intersecting the sheet transporting direction while maintaining a state where the first large diameter portions and the second large diameter portions face each other.

2. The sheet folding device according to claim 1, further comprising:

- a transport portion that transports the sheet to the folding roll again after the sheet on which the folding process is performed by the folding roll is pulled back to an upstream side from the folding roll in a sheet transporting direction,

wherein the contact portion displacement unit moves the folding roll and displaces the contact portion in a direction intersecting the sheet transporting direction when the transport portion pulls back the sheet on which the folding process is performed to the upstream side from the folding roll in the sheet transporting direction.

3. The sheet folding device according to claim 2, wherein the folding roll includes:

- a first roll that includes a plurality of first large diameter portions of which diameters are greater than diameters of the other portions; and
- a second roll that is provided along the first roll and includes a plurality of second large diameter portions of which diameters are greater than diameters of the other portions in positions facing the first large diameter portions, respectively, and

wherein the contact portion displacement unit moves the first roll and the second roll together in a direction intersecting the sheet transporting direction while maintaining a state where the first large diameter portions and the second large diameter portions face each other.

4. A post-processing device comprising:

- a stack portion that stacks a sheet and forms a sheet bundle;
- a folding roll that is rotatably provided and includes a large diameter portion and a small diameter portion, the large diameter portion having a diameter that is greater than a diameter of the small diameter portion, and the folding roller performing a folding process while pressing the large diameter portion onto the sheet bundle formed in the stack portion; and

a contact portion displacement unit that moves the folding roll from a first position to a second position in an axial direction of the folding roll, and makes a contact portion

22

that is a portion of the sheet bundle coming into contact with the large diameter portion when the sheet bundle on which the folding process has been performed by the folding roll passes through the folding roll at the second position different from the contact portion when the sheet bundle passes through the folding roll at the first position,

wherein the folding roll includes

- a first roll that includes a plurality of first large diameter portions of which diameters are greater than diameters of the another portions; and
- a second roll that is provided along the first roll and includes a plurality of second large diameter portions of which diameters are greater than diameters of the another portions in positions facing the first large diameter portions, respectively, and

wherein the contact portion displacement unit moves the first roll and the second roll together in a direction intersecting the sheet transporting direction while maintaining a state where the first large diameter portions and the second large diameter portions face each other.

5. An image forming system comprising:

- an image forming unit that forms an image on a sheet;
- a folding roll that is rotatably provided and includes a large diameter portion and a small diameter portion, the large diameter portion having a diameter that is greater than a diameter of the small diameter portion, and the folding roller performing a folding process while pressing the large diameter portion on the sheet on which an image is formed by the image forming unit; and

a contact portion displacement unit that moves the folding roll from a first position to a second position in an axial direction of the folding roll, and makes a contact portion that is a portion of the sheet coming into contact with the large diameter portion when the sheet on which the folding process has been performed by the folding roll passes through the folding roll at the second position different from the contact portion when the sheet passes through the folding roll at the first position,

wherein the folding roll includes

- a first roll that includes a plurality of first large diameter portions of which diameters are greater than diameters of the another portions; and
- a second roll that is provided along the first roll and includes a plurality of second large diameter portions of which diameters are greater than diameters of the another portions in positions facing the first large diameter portions, respectively, and

wherein the contact portion displacement unit moves the first roll and the second roll together in a direction intersecting the sheet transporting direction while maintaining a state where the first large diameter portions and the second large diameter portions face each other.

6. The sheet folding device according to claim 1, wherein the axial direction is a horizontal direction along an x-axis.

7. The post-processing device according to claim 4, wherein the axial direction is a horizontal direction along an x-axis.

8. The image forming system according to claim 5, wherein the axial direction is a horizontal direction along an x-axis.

* * * * *