



US 20130224888A1

(19) **United States**

(12) **Patent Application Publication**
Nagashima

(10) **Pub. No.: US 2013/0224888 A1**

(43) **Pub. Date: Aug. 29, 2013**

(54) **SYSTEMS AND METHODS FOR
FABRICATING SELF-ALIGNED
RESISTIVE/MAGNETIC MEMORY CELL**

Publication Classification

(71) Applicant: **4D-S PTY, LTD, (US)**

(72) Inventor: **Makoto Nagashima, Perth (AU)**

(73) Assignee: **4D-S PTY, LTD, Perth (AU)**

(21) Appl. No.: **13/759,077**

(22) Filed: **Feb. 5, 2013**

(51) **Int. Cl.**
H01L 43/12 (2006.01)
H01L 45/00 (2006.01)

(52) **U.S. Cl.**
CPC **H01L 43/12** (2013.01); **H01L 45/16** (2013.01)
USPC **438/3**; 438/382

(57) **ABSTRACT**

Systems and methods are disclosed to form a resistive random access memory (RRAM) by forming a first metal electrode layer; depositing an insulator above the metal electrode layer and etching the insulator to expose one or more metal portions; depositing a $\text{Pr}_{1-x}\text{Ca}_x\text{MnO}_3$ (PCMO) layer, in an electrically biased sputtering chamber, above the insulator and the metal portions, to form one or more self-aligned RRAM cells above the first metal electrode; and depositing a second metal electrode layer above the PCMO layer.

Related U.S. Application Data

(62) Division of application No. 11/388,528, filed on Mar. 25, 2006, now Pat. No. 8,395,199.

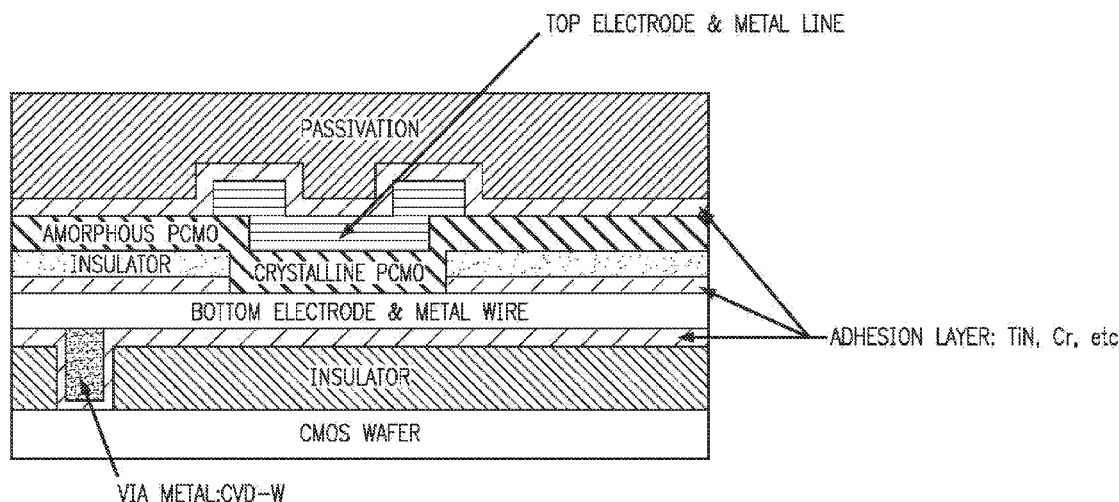

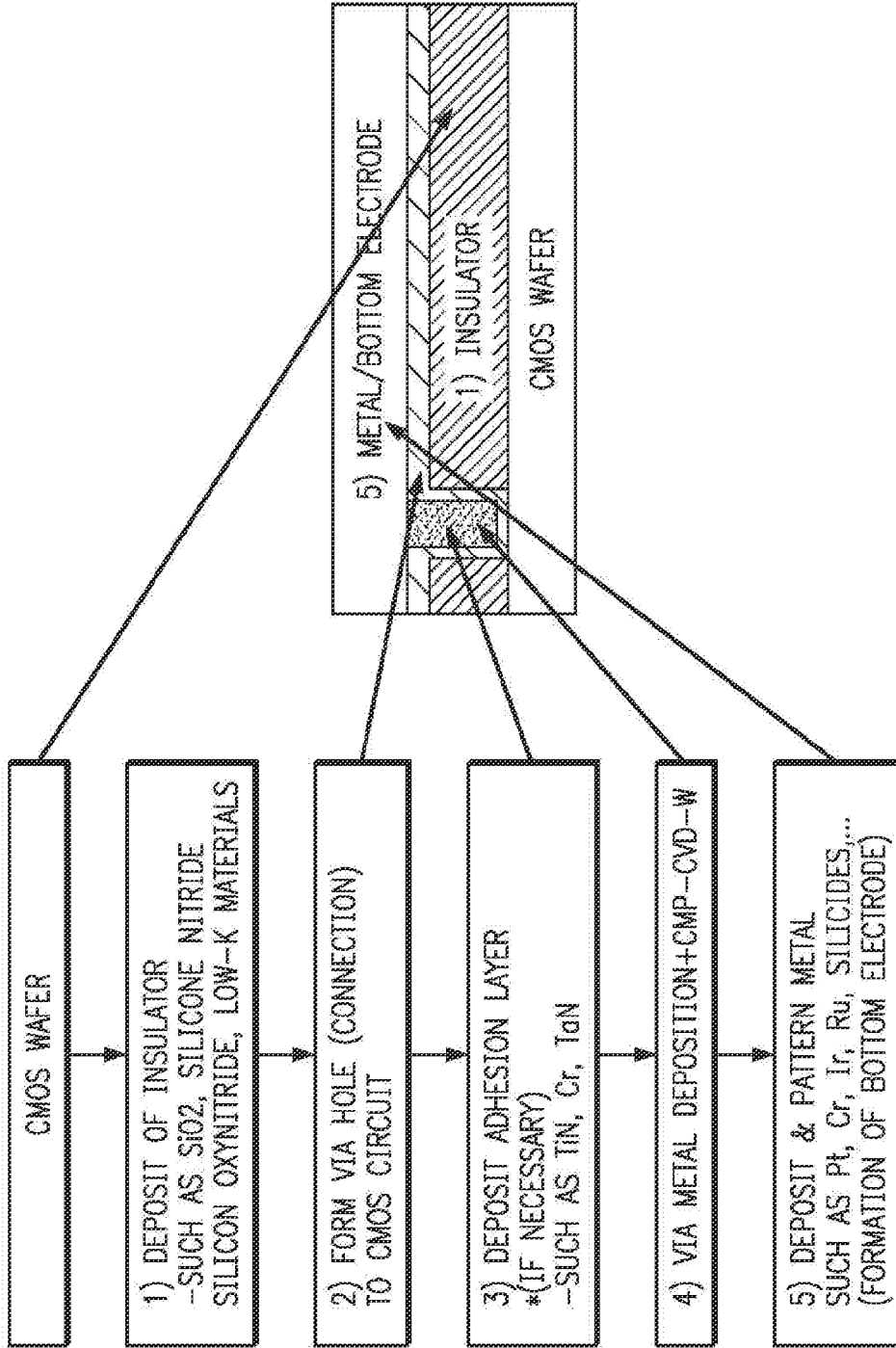

FIG. 1A

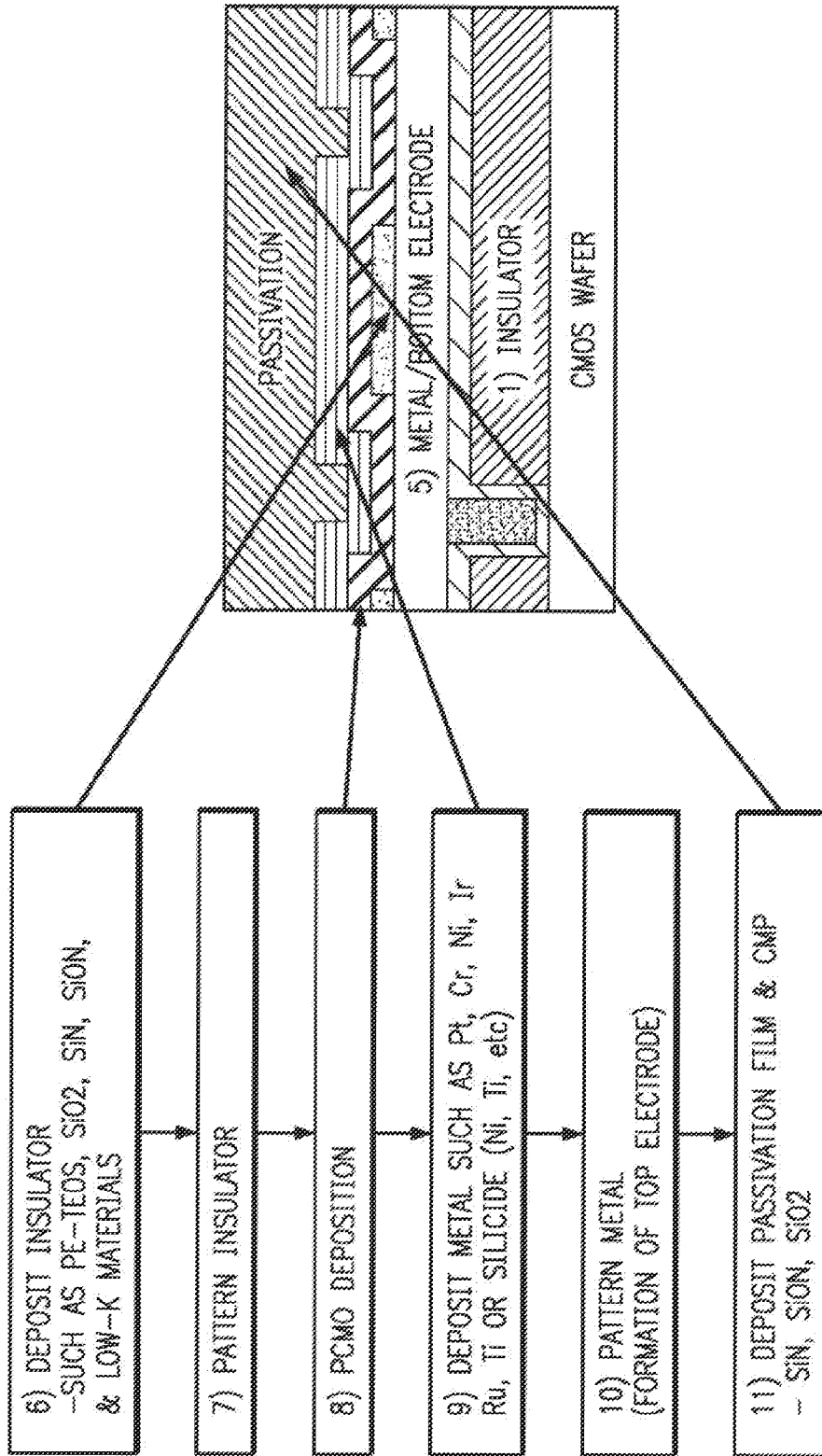

FIG. 1B

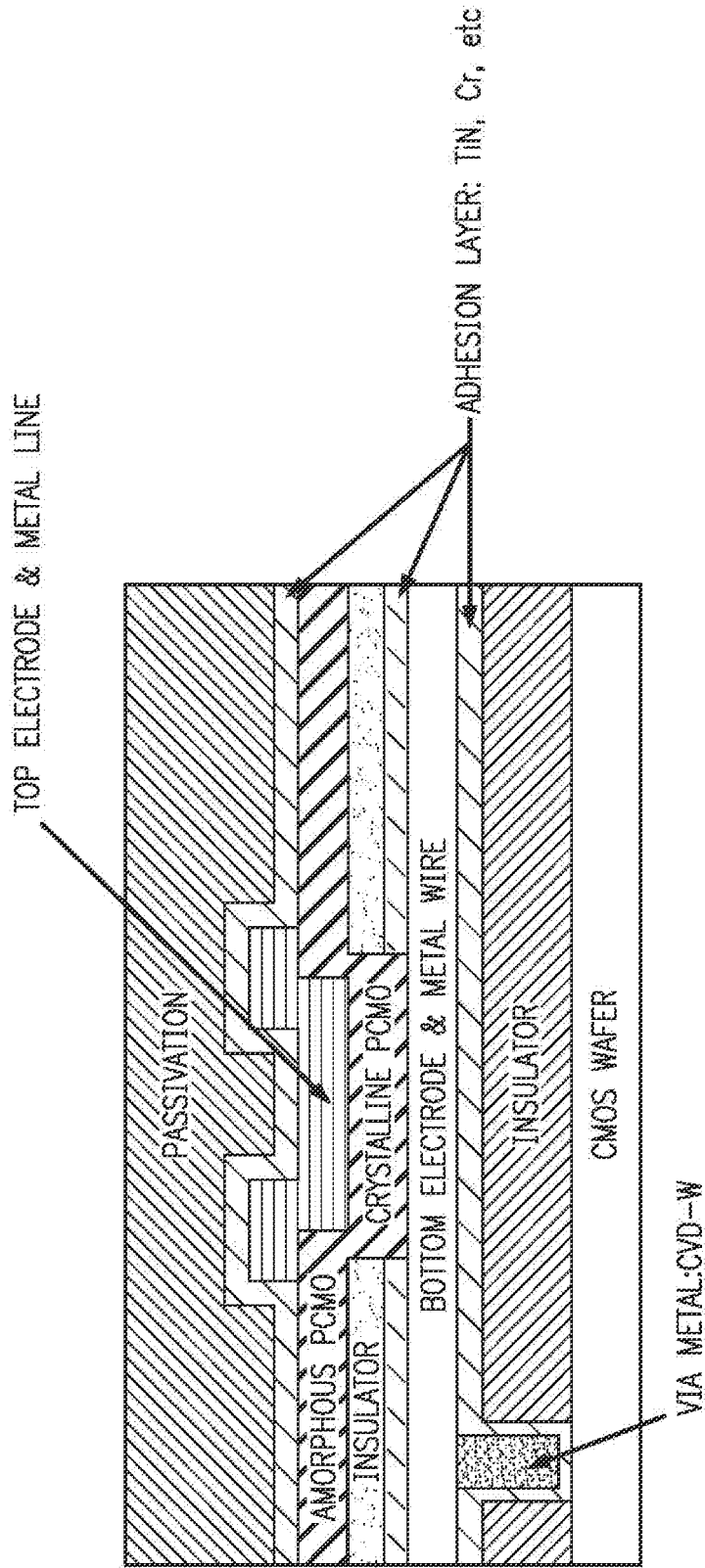

FIG. 1C

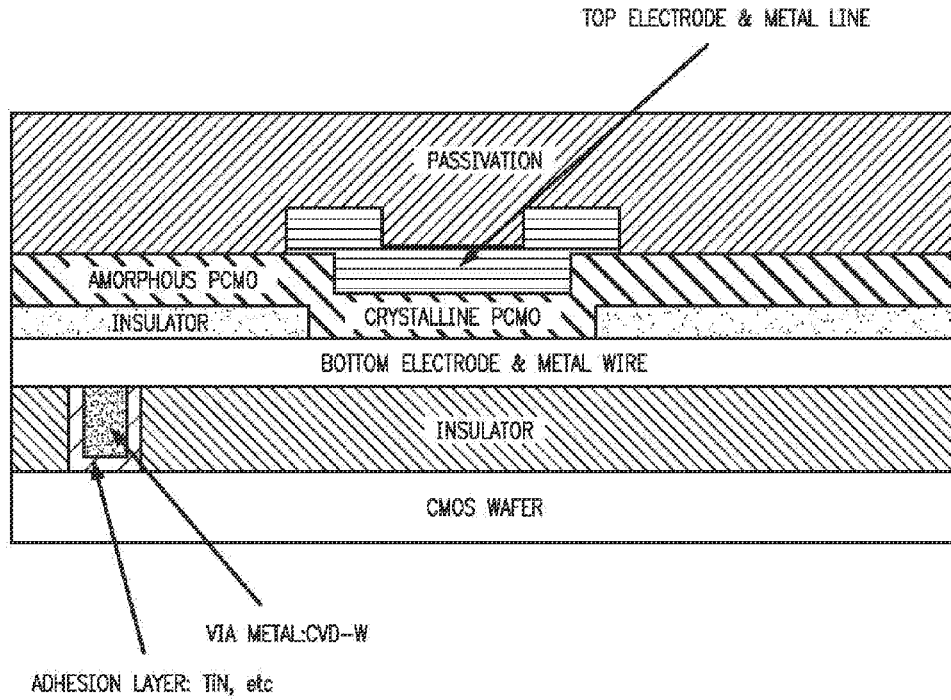

FIG. 1D

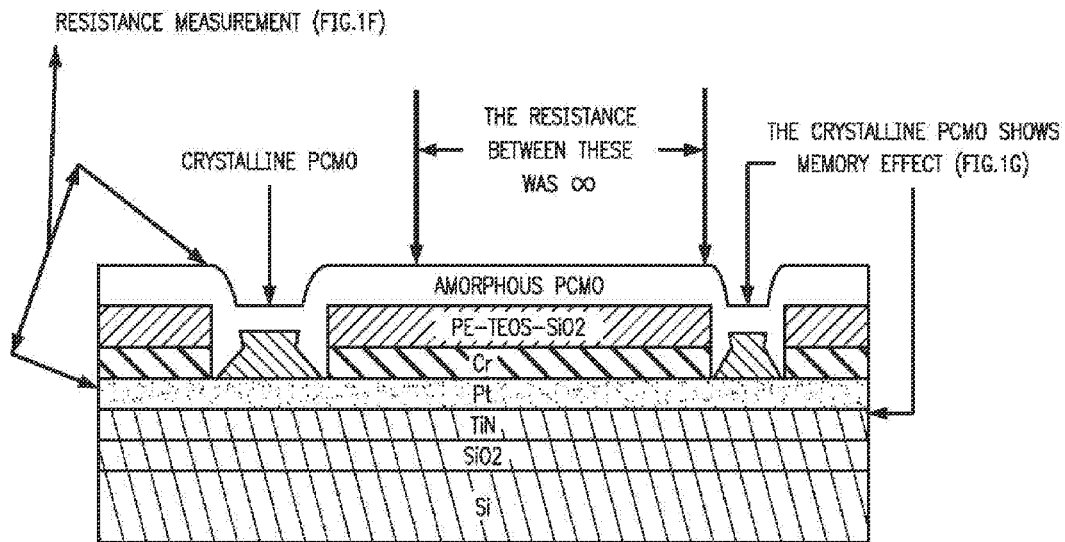

FIG. 1E

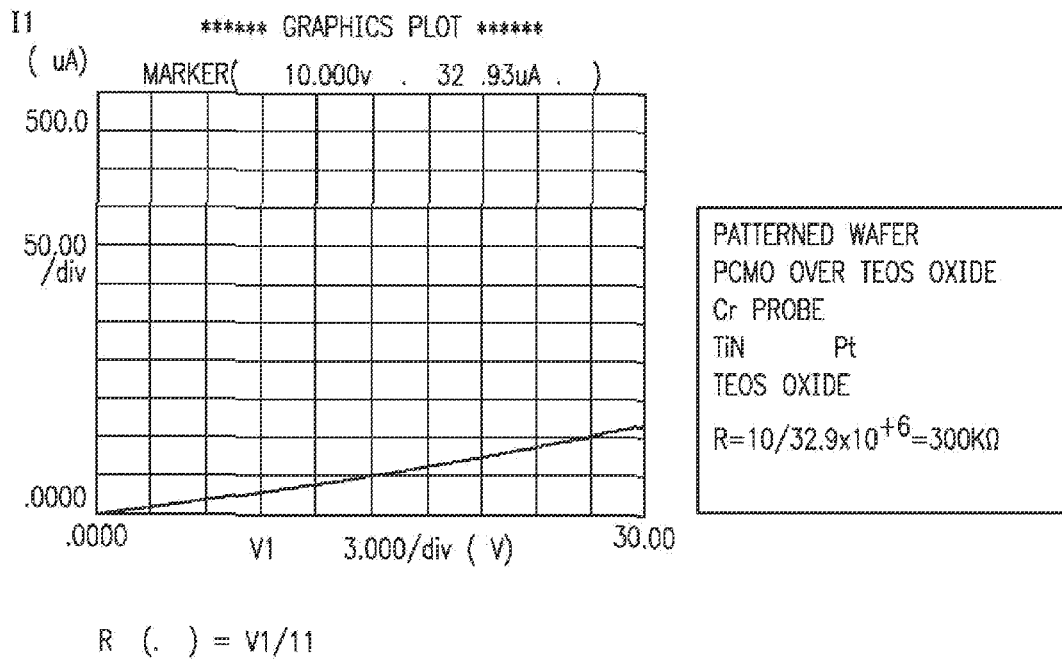
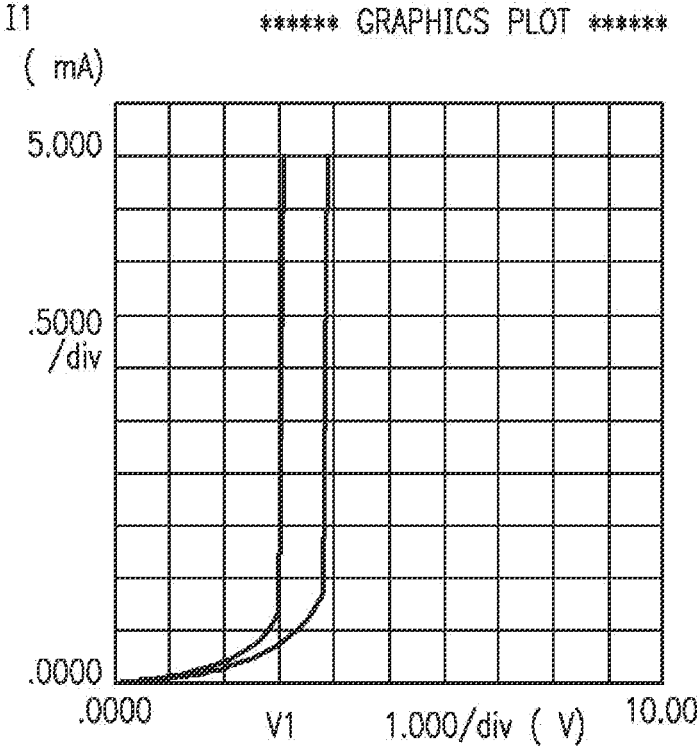

FIG. 1F



$$R (\cdot) = V1/I1$$

FIG. 1G

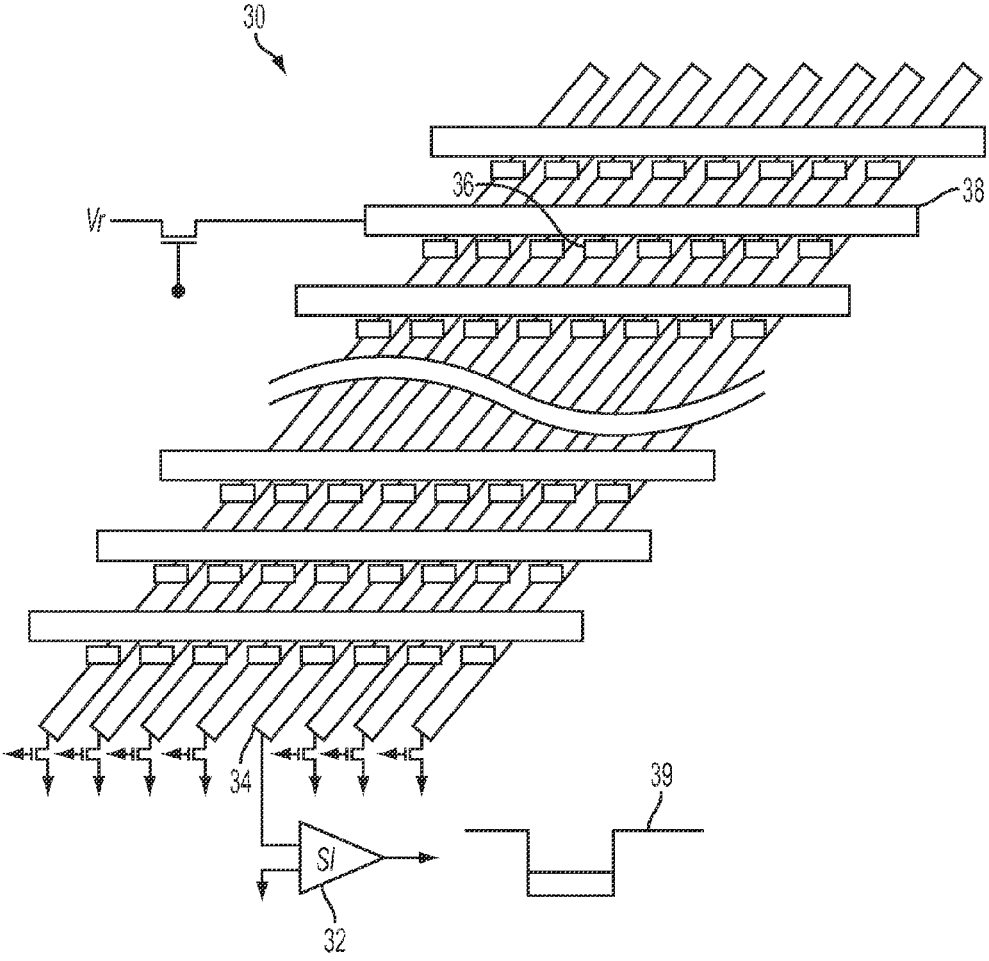

FIG. 2

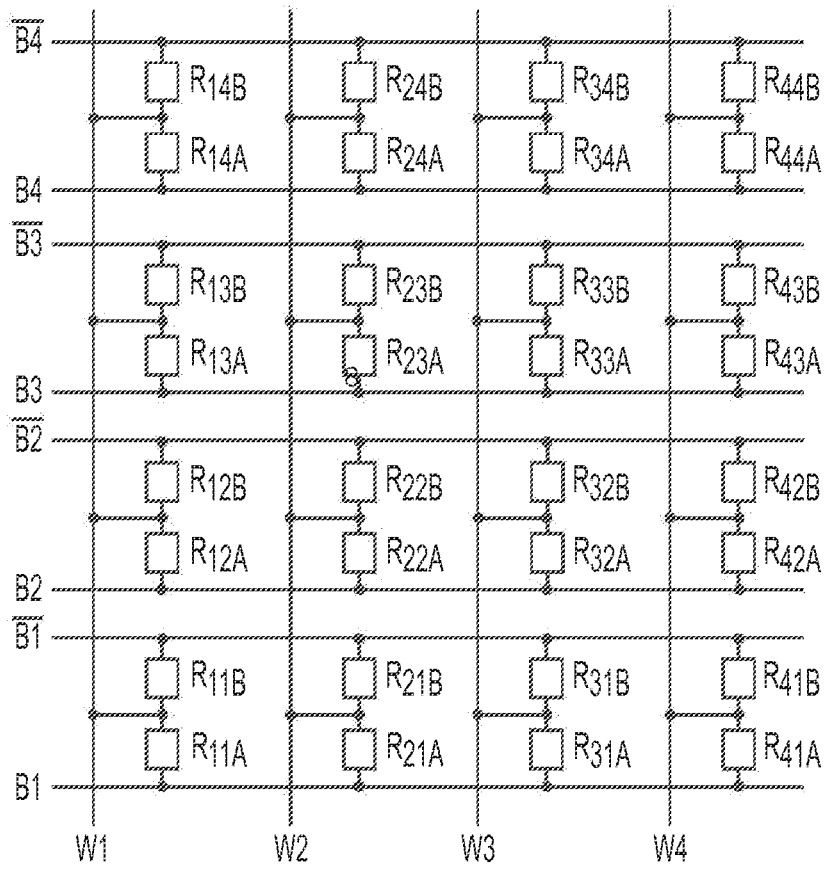

FIG. 3

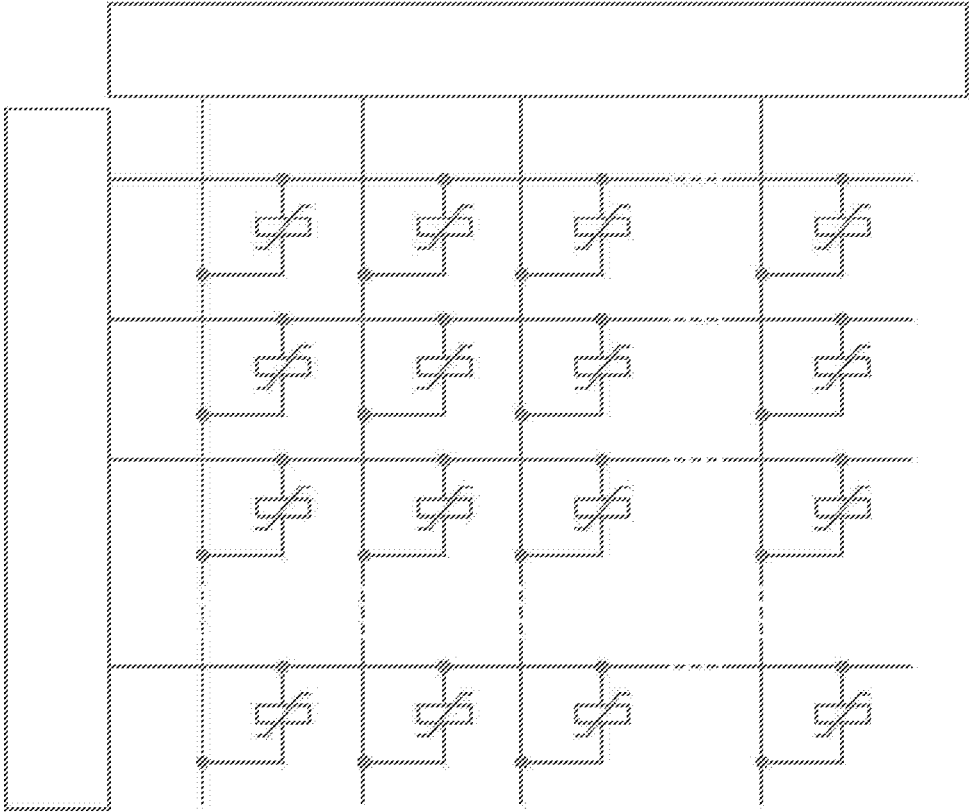

FIG. 4

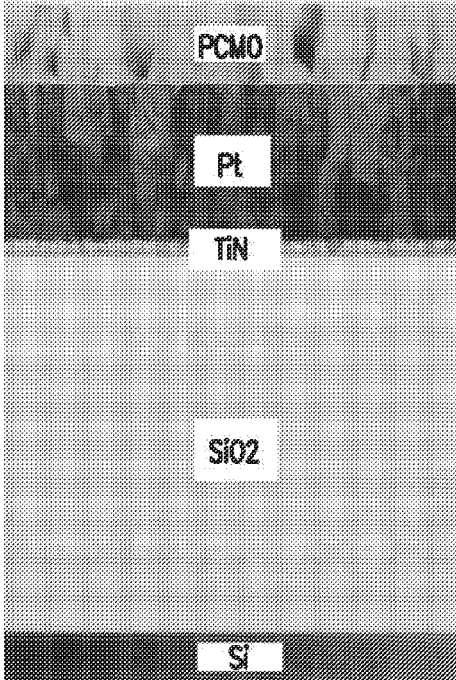

FIG. 5

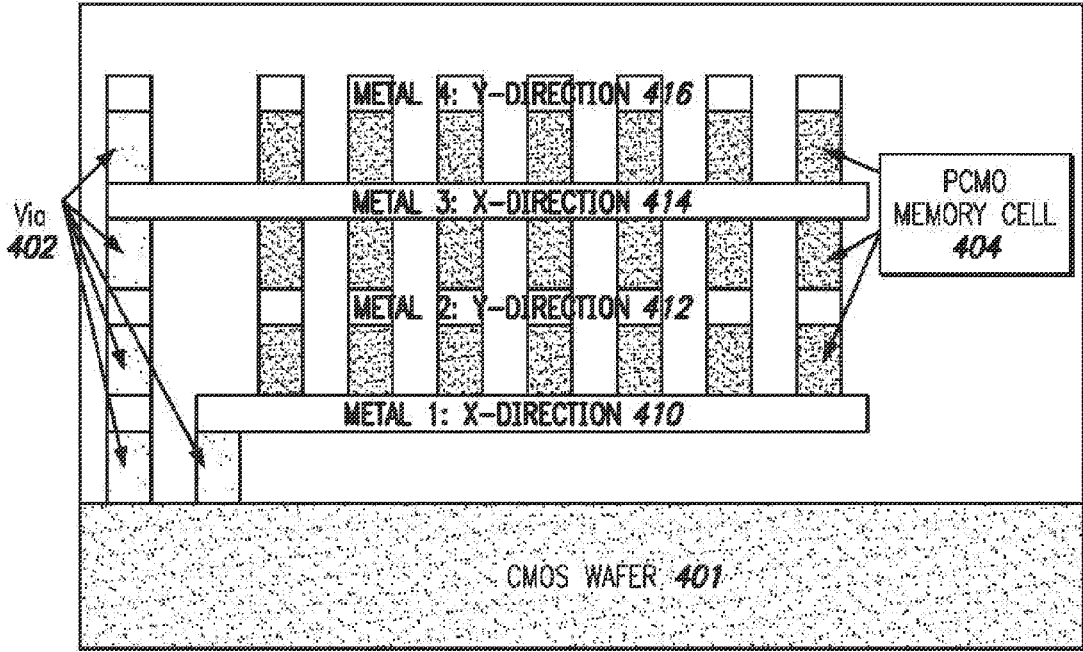

FIG. 6

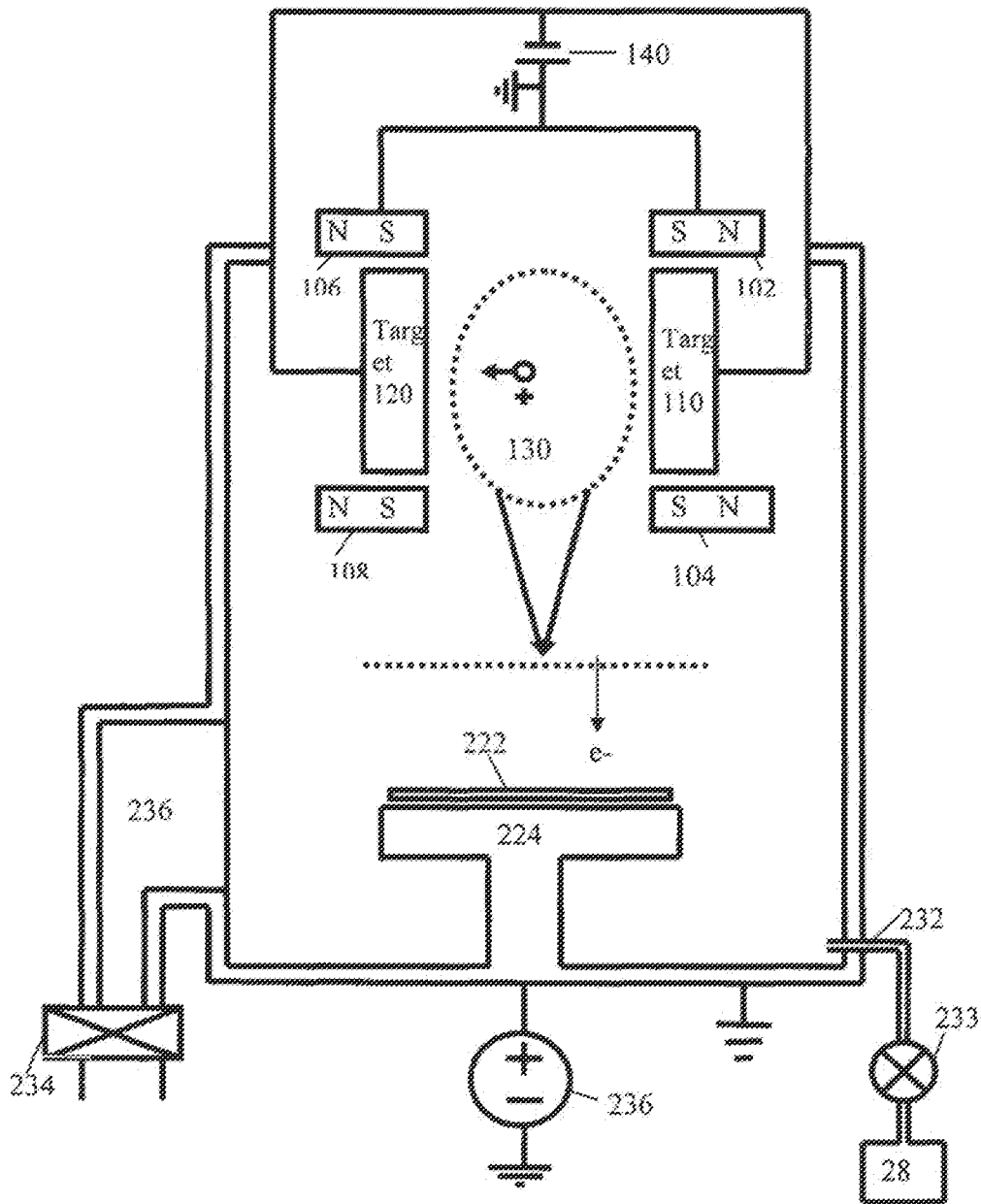

FIG. 7

SYSTEMS AND METHODS FOR FABRICATING SELF-ALIGNED RESISTIVE/MAGNETIC MEMORY CELL

CROSS-REFERENCES TO RELATED APPLICATIONS

[0001] This application is a divisional application of U.S. patent application Ser. No. 11/388,528, filed Mar. 25, 2006, entitled "SYSTEMS AND METHODS FOR FABRICATING SELF-ALIGNED MEMORY CELL." This application is also related to U.S. Pat. No. 7,932,548 and U.S. Pat. No. 8,367,513 entitled "SYSTEMS AND METHODS FOR FABRICATING SELF-ALIGNED MEMORY CELL" and U.S. patent application Ser. No. 13/727,620 filed Dec. 27, 2012. The disclosures of all of the above mentioned applications are all incorporated by reference herein in their entirety for all purposes.

FIELD OF INVENTION

[0002] The present invention relates generally to a self-aligned storage node for a memory device such as a nonvolatile memory device.

BACKGROUND

[0003] A memory device such as random access memory (RAM) is a semiconductor device for storing digital information. Data, as digital information, can be written to and read from a RAM. RAMs are fabricated using integrated circuit technology. For example, a DRAM is made of many storage nodes or memory cells and each memory cell has a memory cell transistor and a capacitor. The capacitor is an important element of the memory cell because it stores the digital information. Trench capacitors and stack capacitors are the two major types of DRAM cell capacitors.

[0004] DRAMs are volatile and thus require power to maintain the data from being lost. Non-volatile alternatives include resistive random access memory (RRAM) devices, each being a cross point type memory array of a planar matrix of spaced memory cells sandwiched between two meshes of conductors running in orthogonal directions above and below the cells. The row conductors running in one direction are referred to as the word lines, and the column conductors extending in a second direction usually perpendicular to the first direction are referred to as the bit lines. The memory cells are usually arranged in a square or rectangular array so that each memory cell unit is connected with one word line and an intersecting bit line.

[0005] In the RRAM array, the resistance of each memory cell has more than one state, and the data in the memory cell is a function of the resistive state of the cell. The resistive memory cells may include one or more magnetic layers, a fuse or anti-fuse, or any element that stores or generates information by affecting the magnitude of the nominal resistance of the element. Other types of resistive elements used in a resistive RAM array include poly-silicon resistors as part of a read-only memory, and floating gate transistors as part of optical memory, imaging devices or floating gate memory devices.

[0006] One type of resistive random access memory is a magnetic random access memory (MRAM), in which each memory cell is formed of a plurality of magnetic layers separated by insulating layers. One magnetic layer is called a pinned layer, in which the magnetic orientation is fixed so as

not to rotate in the presence of an applied magnetic field in the range of interest. Another magnetic layer is referred to as a sense layer, in which the magnetic orientation is variable between a state aligned with the state of the pinned layer and a state in misalignment with the state of the pinned layer. An insulating tunnel barrier layer sandwiches between the magnetic pinned layer and the magnetic sense layer. This insulating tunnel barrier layer allows quantum mechanical tunneling to occur between the sense layer and the pinned layer. The tunneling is electron spin dependent, causing the resistance of the memory cell, a function of the relative orientations of the magnetizations of the sense layer and the pinned layer. The variations in the junction resistance for the two states of the sense layer determine the data stored in the memory cell. U.S. Pat. No. 6,169,686, granted to Brug et al. on Jan. 2, 2001 discloses such a magnetic memory cell memory. U.S. Pat. No. 6,385,079 discloses a method for designing a resistive random access memory array in which elements are selected with values of resistances that are correlated to maintain a signal-to-noise ratio of 20 decibels or more for the array. A plurality of memory cells are selected and spaced from each other in a matrix of rows and columns, each memory cell being selected to have a junction resistance value of between 0.25 megaohms and 3.60 megaohms. A plurality of conductive row lines are selected and connected between a number N of memory cells in each row, each row and column line being selected to have a row or column unit line resistance value below 0.38 ohms, so that the values of junction resistance are correlated with the values of the row and column unit line resistance to provide a signal-to-noise ratio of 20 decibels or more for the memory array. The values of the row and column unit line resistance are selected so that the total row line resistance for each row is approximately equal to the total column line resistance for each column. The ratio of the junction resistance to the unit line resistance is approximately five million to one, in order to maintain a signal-to-noise ratio of at least 20 decibels in the resistive memory array. For an equal number N of row and column elements, the total row or column line resistance must be greater than approximately five million to N. If N is equal to approximately 1000, the ratio of junction resistance to total row or column line resistance must be approximately 5,000 or greater.

SUMMARY

[0007] In one aspect, systems and methods are disclosed to form a resistive random access memory (RRAM) by forming a first metal electrode layer; depositing an insulator above the metal electrode layer and etching the insulator to expose one or more metal portions; depositing a $\text{Pr}_{1-x}\text{Ca}_x\text{MnO}_3$ (PCMO) layer, in an electrically biased sputtering chamber, above the insulator and the metal portions, to form one or more self-aligned RRAM cells above the first metal electrode; and depositing a second metal electrode layer above the PCMO layer. X can also be between 0.2 and 0.8 in another embodiment.

[0008] In another aspect, a magnetic random access memory (MRAM) includes an amorphous PCMO or silicon material portion and a polycrystalline PCMO portion adjacent the amorphous material to form one or more self-aligned MRAM cells.

[0009] In another aspect, a resistive random access memory (RRAM) includes a first metal electrode layer; an insulator material deposited and patterned above the metal electrode layer; a $\text{Pr}_{1-x}\text{Ca}_x\text{MnO}_3$ (PCMO) layer forming one or more

self-aligned RRAM cells above the first metal electrode layer, where X is between approximately 0.3 and approximately 0.5; and a second metal electrode layer deposited above the first metal electrode layer.

[0010] In yet another aspect, a resistive random access memory (RRAM) includes an insulator material deposited and patterned; and a PCMO layer deposited above the patterned insulator material forming one or more self-aligned RRAM cells without any etching of the PCMO layer.

[0011] In another aspect, a resistive random access memory (RRAM) includes an amorphous PCMO or silicon material portion and a polycrystalline PCMO portion adjacent the amorphous material to form one or more self-aligned RRAM cells without any etching thereto.

[0012] Implementations of the above aspects may include one or more of the following. The PCMO layer is simply deposited over the insulator to form amorphous PCMO. Where the insulator has been patterned to expose the metal, polycrystalline PCMO forms the RRAM without requiring etching of the PCMO layer. This simplifies the manufacturing process significantly and allows smaller geometry to be achieved. The metal layer can be a transition metal such as chromium, platinum, nickel, ruthenium, copper, and others, a silicide such as nickel silicide, and a Mott insulator such as LNO(LaNiO₃). As chromium and LNO are “sticky” materials, an adhesion layer is not needed.

[0013] In other implementations, an insulator layer can be formed between a wafer and the first metal electrode layer. The first metal electrode layer can be formed above a wafer. Via holes connect the first metal electrode layer to circuit on the wafer. An adhesion layer can be formed above the first metal electrode layer. A metal can be formed above the via holes, and the metal is polished using chemical mechanical polishing. The first or second metal electrode layer can be platinum, chromium, iridium, ruthenium, nickel, silicide, nickel, titanium or LNO. A passivation film can be formed above the second electrode metal layer. Each memory cell can be one of: a two terminal memory device, a three terminal memory device. The PCMO layer can be deposited above the insulator material to form an amorphous PCMO. Alternatively, the PCMO layer can be deposited above the metal openings to form polycrystalline PCMO. A plurality of metal layers and vias can connect the RRAM cells to a wafer circuit. The PCMO layers can be stacked to form a 3-dimensional RAM structure.

[0014] Advantages of the invention may include one or more of the following. The system provides a low-cost high density solid state memory device. The memory units can be interconnected within a wafer, and the wafers are interconnected in a stacked wafer construction of a memory system. The resulting semiconductor device offers high density storage at a very low cost. Moreover, the process can be done at low temperature. The substrate temperature in forming a thin film approximately at the range of 300-400 deg. C. and the process requires a short time. Since the thin film is formed at a very low temperature during substantially the whole process, the process can be applied to a highly integrated device to deposit an additional memory layer with a plurality of elements without damaging other elements previously deposited using conventional deposition.

BRIEF DESCRIPTION OF DRAWINGS

[0015] In order that the manner in which the above-recited and other advantages and features of the invention are

obtained, a more particular description of the invention briefly described above will be rendered by reference to specific embodiments thereof, which are illustrated, in the appended drawings. Understanding that these drawings depict only typical embodiments of the invention and are not therefore to be considered to be limiting of its scope, the invention will be described and explained with additional specificity and detail through the use of the accompanying drawings in which:

[0016] FIGS. 1A-1B show an exemplary process to fabricate a self-aligned memory cell.

[0017] FIG. 1C shows an exemplary memory structure with an adhesion layer, while

[0018] FIG. 1D shows an exemplary memory structure without an adhesion layer.

[0019] FIG. 1E shows an exemplary memory structure with platinum plating.

[0020] FIGS. 1F-1G show exemplary electrical characteristics of the memory device of FIG. 1E.

[0021] FIG. 2 shows a first exemplary RRAM memory array with two-terminal memory cells.

[0022] FIG. 3 depicts a second exemplary RRAM array with a complementary output (three terminal memory cell).

[0023] FIG. 4 shows an exemplary MRAM array.

[0024] FIG. 5 shows a cross sectional TEM view of an exemplary PCMO RRAM Memory Cell.

[0025] FIG. 6 shows an exemplary multi-level RRAM.

[0026] FIG. 7 shows an exemplary apparatus for fabricating semiconductor.

DETAILED DESCRIPTION OF PREFERRED EMBODIMENTS

[0027] Referring now to the drawings in greater detail, there is illustrated therein structure diagrams for a semiconductor processing system and logic flow diagrams for processes a system will utilize to deposit a memory device, as will be more readily understood from a study of the diagrams.

[0028] FIGS. 1A-1B show an exemplary process to fabricate a self-aligned memory cell. The process uses CMOS wafers and conventional CMOS circuits or structures may be formed on the wafer prior to the memory cell fabrication. One or more electronic devices can be formed on the wafer. The process forms non-volatile memory such as RRAM or MRAM. Unlike conventional DRAM, which uses electrical cells (e.g., capacitors) to store data, MRAM uses magnetic cells. Because magnetic memory cells maintain their state even when power is removed, RRAM or MRRAM possesses a distinct advantage over electrical cells.

[0029] Turning now to FIG. 1A, the process deposits an insulator such as silicon dioxide, silicon nitride, silicon oxynitride, or any other suitable low-K materials (1). Next, via holes are formed to provide connections to the CMOS circuits (2). The process then optionally deposits an adhesion layer such as titanium nitride, chromium, or tantalum nitride, among others (3). Next, the process deposits via metal and performs Chemical Mechanical Polishing (CMP) as well as Chemical Vapor Deposition (CVD), among others (4). Next, metal is deposited and patterned to form bottom electrodes using metals such as platinum, chromium, iridium, ruthenium, nickel, or silicides such as nickel or titanium, among others (5).

[0030] In FIG. 1B, the process deposits an insulator material such as silicon dioxide, silicon nitride, silicon oxynitride or any suitable low K materials (6). Next, the insulator mate-

rial is patterned (7). PCMO is then deposited (8). The polycrystalline PCMO is deposited on the metal exposed area and the amorphous PCMO is deposited on the insulator material. A via hole is then formed to connect the PCMO to a top electrode that in turn is connected to a CMOS circuit. Next, metal is deposited and patterned to form top electrodes using metals such as platinum, chromium, iridium, ruthenium, nickel, or silicides such as nickel or titanium, among others (8). The metal is patterned to form a top electrode (9). The process then deposits a passivation film layer such as silicon nitride, silicon oxynitride, or silicon dioxide, among others, and then perform CMP as necessary (10).

[0031] The process of FIGS. 1A-1B forms a variable resistor which can be programmed to have high resistance or low resistance (in two-state memory circuits), or any intermediate resistance value (in multi-state memory circuits). The different resistance values of the RRAM cell represent the information stored in the RRAM circuit.

[0032] The resulting RRAM is simple and small in size with advantages from the nonvolatile characteristic of the resistor memory cell and the stability of the memory state. Since resistor is a passive component and cannot actively influence nearby electrical components, a basic RRAM cell can be just a variable resistor, arranged in a cross point resistor network to form a cross point memory array. To prevent cross talk or parasitic current path, a RRAM cell can further include a diode, and this combination is sometimes called a 1R1D (or 1D1R) cross point memory cell. To provide better access, a RRAM can include an access transistor, as in DRAM or FRAM cell, and this combination is sometimes called a 1R1T (or 1T1R) cross point memory cell.

[0033] The resistance state of a RRAM cell is referred to the storing (writing) or sensing (reading) methodology of the RRAM circuit. The term resistance state is related to the resistance value of the memory resistor (the resistance state can then be said to be the resistance of the memory resistor), but sensing the resistance value of the memory resistor often means sensing the voltage across the memory resistor (the resistance state can then be said to be the voltage across the memory resistor), or sensing the current through the memory resistor (the resistance state then can be said to be the current through the memory resistor). The resistance states of the RRAM can be represented by different techniques such as structural state, polarization, or magnetization.

[0034] The PCMO layer is simply deposited over the insulator to form amorphous PCMO which is a typical insulator. Where the insulator has been patterned away to expose the metal layer, the PCMO layer is polycrystalline PCMO which exhibits RRAM capability. The RRAM is formed and does not need etching of PCMO, simplifying the manufacturing process significantly and allowing smaller geometry to be achieved. The metal layer can be a transition metal such as chromium, nickel, ruthenium, copper, or nickel silicide, among others. As chromium is a "sticky" material, an adhesion layer is not needed. If the metal layer is platinum, an adhesive layer may be used to allow other materials to adhere to the platinum layer.

[0035] FIG. 1C shows an exemplary memory structure where the metal material such as Pt, Ru, Ir, among others, requires an adhesion layer with an insulator interface. In FIG. 1C, an insulator is formed above a wafer such as a CMOS wafer. The insulator is etched and an adhesion layer such as TiN, TaN or Cr is deposited, resulting in a via with a metal such as CVD W and CMP. Next, a bottom electrode and metal

wire is formed. An insulator is deposited and suitably patterned. A PCMO is then deposited. A second adhesion layer of TiN or Cr is then deposited, and a top electrode and metal line is formed. A passivation insulator is then formed to protect the circuitry. FIGS. 1F-1G show exemplary electrical characteristics of the memory device of FIG. 1C.

[0036] FIG. 1D shows an exemplary memory structure where the metal material such as Cr, among others, does not need an adhesion layer with an insulator interface. Similar to FIG. 1C, an insulator is formed above a wafer such as a CMOS wafer. The insulator is etched and an adhesion layer such as TiN or Cr is deposited in a via with a metal such as CVD W and CMP. Next, a bottom electrode and metal wire is formed. An insulator is deposited and patterned. Then a PCMO layer is deposited. Where the PCMO is deposited above the insulator, an amorphous PCMO is formed. Where the PCMO is deposited to exposed metal surface, a polycrystalline PCMO is formed. A top electrode and metal line is formed, and a passivation insulator is then formed to protect the circuitry.

[0037] FIG. 1E shows an exemplary cross sectional view of an exemplary PCMO memory. In FIG. 1E, the selective-plating with platinum (Pt) forms the bottom electrode on the metal wire. The crystalline PCMO grows on a platinum surface and no crystalline PCMO was grown on insulators such as SiO₂ and SiN, among others. The metal layer can be aluminum, tungsten, chromium, nickel or copper, or a suitable metal. The metal can also be a noble metal such as Pt or In, but these materials are difficult to work with. The insulator can be SiN, SiON, SiO₂ or other insulators. FIG. 1F shows an exemplary resistance measurement of the points noted in FIG. 1E, while FIG. 1G shows the memory effect of the device of FIG. 1E.

[0038] Referring to FIG. 2, a first exemplary RRAM memory array 30 with two-terminal memory cells is shown. A sense amplifier 32 is connected to the bit line 34 of a selected memory cell 36. Each cell 36 has logic states "1" and "0" that correspond to a low resistance state and a high resistance state, respectively. The cell 36 can also have multiple states, enabling multiple states such as 256 states to be stored in one cell, resulting in high density storage cells. The resistance of a selected memory cell 36 may be changed by applying currents to a word line 12 and a bit line 14 crossing the selected memory cell. A voltage V_r is applied to the word line 38 of the selected memory cell 36, and sense amplifier 32 applies a voltage to the bit line 34 of cell 36. The sense amplifier 32 provides an amplified output 39 reflecting the state of the memory cell 36. The same bit line voltage is applied to all of the bit line 34, effectively biasing all the cells on unselected rows to zero potential. This action isolates the bit line currents from one another, effectively blocking most of the leakage current that might otherwise flow through secondary paths where such leakage may possibly cause errors in the sensing function of the selected memory cell.

[0039] FIG. 3 depicts a second exemplary RRAM array with a complementary output (three terminal memory cell). Each memory cell consists of two memory resistors formed in accordance with FIGS. 1A-1B. Each of the complementary bit lines is connected to the respect input of a differential amplifier, which was not shown in this figure. The output of the differential amplifier may be connected to an inverter for a digital output at either "0" or "1" state. The RRAM thin film can have a uniform material property, in which case the RRAM can be programmed in one step. Alternatively, for

high density or for processes that do not provide uniform thin film deposition, a two-step programming may be applied to any non-uniform property RRAM thin film memory cell.

[0040] The one-step programming process will be discussed first. The selected cell is W2B2 and a first related bit line, B22, will be programmed to high voltage bit and a second related bit line, B22, will be programmed to low voltage bit. The word line, W2 is floated. All other word lines are biased with half-programming pulse voltage. Bit line B22 is grounded. Programming pulse, VP is applied to B22. All other bit lines are biased to the ground potential. As a result the resistor R22A is at the low resistance-state and the resistor B22B is at the high resistance-state. All memory resistor in the bit 2 other than that connected to W2 word lines are biased with half of the programming voltage. Therefore, there is no resistance change. Similarly each bit lines along the W2 may be properly biased to program one word at a time. After programming, the two memory cell resistors in any given bit are at the high resistance-state and low resistance-state, respectively.

[0041] The two-step programming is more conventional. Again, cell W2B2 is selected in this example. A first selected memory resistor, R22A and memory resistor R22B are programmed to a low resistance state and to a high resistance-state, respectively. The selected word line, W2, is set to ground potential, and all other word lines are biased to 0.5 VP. A negative programming pulse, having pulse amplitude of -VP, and a positive programming pulse, having amplitude of +VP, with appropriate pulse widths, are applied to bit lines B2 and B2, respectively. The positive and the negative programming pulses do not have to be applied simultaneously, and the A resistor and the B resistor may be programmed separately. Memory resistors, R22A and R22B, are, therefore, programmed to a low resistance state, RL and a high resistance state, RH, respectively. All other memory resistors are either pulsed with half of the programming pulse voltage, or not pulsed. Therefore, the resistance of the non-selected memory resistors will not change during this programming operation.

[0042] The memory array may be read by applying a read voltage to the word line and detecting (reading) the voltage difference between the bit lines which share the memory cell.

[0043] In one embodiment, the MRAMs can be formed with two small magnetic layers separated by a thin insulating layer typically make up each memory cell, forming a tiny magnetic "sandwich." Each magnetic layer behaves like a tiny bar magnet, with a north pole and south pole, called a magnetic "moment." The moments of the two magnetic layers can be aligned either parallel (north poles pointing in the same direction) or antiparallel (north poles pointing in opposite directions) to each other. These two states correspond to the binary states—the 1's and 0's—of the memory. The memory writing process aligns the magnetic moments, while the memory reading process detects the alignment. Data is read from a memory cell by determining the orientation of the magnetic moments in the two layers of magnetic material in the cell. Passing a small electric current directly through the memory cell accomplishes this: when the moments are parallel, the resistance of the memory cell is smaller than when the moments are not parallel. Even though there is an insulating layer between the magnetic layers, the insulating layer is so thin that electrons can "tunnel" through the insulating layer from one magnetic layer to the other.

[0044] To write to an MRAM cell, currents pass through wires close to (but not connected to) the magnetic cell.

Because any current through a wire generates a magnetic field, this field can change the direction of the magnetic moment of the magnetic material in the magnetic cell. The arrangement of the wires and cells is called a cross-point architecture: the magnetic junctions are set up along the intersection points of a grid. Word lines run in parallel on one side of the magnetic cells. Bit lines runs on a side of the magnetic cells opposite the word lines. The bit lines are perpendicular to the set of word lines below. Like coordinates on a map, choosing one particular word line and one particular bit line uniquely specifies one of the memory cells. To write to a particular cell (bit), a current is passed through the word line and bit line that intersect at that particular cell. Only the cell at the crosspoint of the word line and the bit line sees the magnetic fields from both currents and changes state.

[0045] In one exemplary memory cell array shown in FIG. 4, word lines for selecting rows and bit lines for selecting columns are arranged to intersect at right angles. Memory cells are formed at intersections, and a peripheral driver circuit for selectively allowing information to be written into or read from the memory cells and an amplifier circuit which for reading the information are also formed. The peripheral circuit section includes a word line driver circuit and bit line driver circuit and a signal detecting circuit such as a sense amplifier, for example.

[0046] FIG. 5 shows a cross sectional TEM view of an exemplary PCMO RRAM memory cell. IN this RRAM embodiment, the memory device is formed of silicon (Si), silicon oxide (SiO₂), titanium nitride (TiN), platinum (Pt), and PCMO material, respectively.

[0047] FIG. 6 shows an exemplary multi-level RRAM. In FIG. 6, vias 402 enable connections to be made from a wafer 401 to a plurality of metal lines 410-416 along the X and Y axis to select and access a plurality of RRAM cells 404 formed above the wafer 401.

[0048] FIG. 7 shows one embodiment of an apparatus for fabricating semiconductor, such as an RRAM or MRAM. An embodiment reactor 10 is schematically illustrated in FIG. 7. The reactor 10 includes a metal chamber 14 that is electrically grounded. A wafer or substrate 22 to be sputter coated is supported on a pedestal electrode 24 in opposition to the target 16. An electrical bias source 26 is connected to the pedestal electrode 24. Preferably, the bias source 26 is an RF bias source coupled to the pedestal electrode 24 through an isolation capacitor. Such bias source produces a negative DC self-bias VB on the pedestal electrode 24 on the order of tens of volts. A working gas such as argon is supplied from a gas source 28 through a mass flow controller 30 and thence through a gas inlet 32 into the chamber. A vacuum pump system 34 pumps the chamber through a pumping port 36.

[0049] A face target sputtering (FTS) unit is positioned to face the wafer 22 and has a plurality of magnets 102, 104, 106, and 108. A first target 110 is positioned between magnets 102 and 104, while a second target 120 is positioned between magnets 106 and 108. The first and second targets 110 and 120 define an electron confining region 130. A power supply 140 is connected to the magnets 102-108 and targets 110-120 so that positive charges are attracted to the second target 120. During operation, particles are sputtered onto a substrate 150 which, in one embodiment where the targets 110 and 120 are laterally positioned, is vertically positioned relative to the lateral targets 110 and 120. The substrate 150 is arranged to be perpendicular to the planes of the targets 110 and 120. A substrate holder 152 supports the substrate 150.

[0050] The targets **110** and **120** are positioned in the reactor **10** in such a manner that two rectangular shape cathode targets face each other so as to define the plasma confining region **130** there between. Magnetic fields are then generated to cover vertically the outside of the space between facing target planes by the arrangement of magnets installed in touch with the backside planes of facing targets **110** and **120**. The facing targets **110** and **120** are used a cathode, and the shield plates are used as an anode, and the cathode/anode are connected to output terminals of the direct current (DC) power supply **140**. The vacuum vessel and the shield plates are also connected to the anode.

[0051] Under pressure, sputtering plasma is formed in the space **130** between the facing targets **110** and **120** while power from the power source is applied. Since magnetic fields are generated around the peripheral area extending in a direction perpendicular to the surfaces of facing targets **110** and **120**, highly energized electrons sputtered from surfaces of the facing targets **110** and **120** are confined in the space between facing targets **110** and **120** to cause increased ionized gases by collision in the space **130**. The ionization rate of the sputtering gases corresponds to the deposition rate of thin films on the substrate **22**, then, high rate deposition is realized due to the confinement of electrons in the space **130** between the facing targets. The substrate **22** is arranged so as to be isolated from the plasma space between the facing targets **110** and **120**.

[0052] Film deposition on the substrate **22** is processed at a low temperature range due to a very small number of impingement of plasma from the plasma space and small amount of thermal radiation from the target planes. A typical facing target type of sputtering method has superior properties of depositing ferromagnetic materials at high rate deposition and low substrate temperature in comparison with a magnetron sputtering method. When sufficient target voltage VT is applied, plasma is excited from the argon. The chamber enclosure is grounded. The RF power supply **26** to the chuck or pedestal **24** causes an effective DC ‘back-bias’ between the wafer and the chamber. This bias is negative, so it repels the low-velocity electrons.

[0053] The electron distribution follows a standard Maxwellian curve. Low energy electrons have two characteristics: they are numerous and they tend to have non-elastic collisions with the deposited atoms, resulting in amorphization during deposition. High-energy electrons come through the back-biased shield, but they effectively ‘bounce’ off the atoms without significant energy transfer—these electrons do not affect the way bonds are formed. This is especially true because high energy electrons spend very little time in the vicinity of the atoms, while the low energy electrons spend more time next to the atoms and can interfere with bond formation.

[0054] The presence of the large positively biased shield affects the plasma, particularly close to the pedestal electrode **24**. As a result, the DC self-bias developed on the pedestal **24**, particularly by an RF bias source, may be more positive than for the conventional large grounded shield, that is, less negative since the DC self-bias is negative in typical applications. It is believed that the change in DC self-bias arises from the fact that the positively biased shield drains electrons from the plasma, thereby causing the plasma and hence the pedestal electrode to become more positive.

[0055] It is to be understood that various terms employed in the description herein are interchangeable. Accordingly, the above description of the invention is illustrative and not lim-

iting. Further modifications will be apparent to one of ordinary skill in the art in light of this disclosure.

What is claimed is:

1. A method to form a resistive random access memory (RRAM), comprising:
 - a. forming a first metal electrode layer;
 - b. depositing an insulator above the metal electrode layer and etching the insulator to expose one or more metal portions;
 - c. depositing a $\text{Pr}_{1-x}\text{Ca}_x\text{MnO}_3$ (PCMO) layer in an electrically biased sputtering chamber above the insulator and the metal portions, to form one or more self-aligned RRAM cells above the first metal electrode; and
 - d. depositing a second metal electrode layer above the PCMO layer.
2. The method of claim 1, comprising depositing and patterning an insulator layer between a wafer and the first metal electrode layer.
3. The method of claim 1, wherein the electrically biased sputtering chamber comprises facing targets.
4. The method of claim 3, comprising forming via holes to connect the first metal electrode layer to circuit on the wafer.
5. The method of claim 4, comprising depositing metal above the via holes.
6. The method of claim 3, comprising depositing an adhesion layer above the first metal electrode layer.
7. The method of claim 6, comprising performing chemical mechanical polishing on the deposited metal.
8. The method of claim 1, wherein one of the metal electrode layer comprises one of: platinum, chromium, iridium, ruthenium, nickel, silicides, nickel, and titanium.
9. The method of claim 1, comprising depositing a passivation film.
10. The method of claim 9, comprising performing chemical mechanical polishing on the passivated film.
11. A method to form a magnetic random access memory (MRAM), comprising:
 - a. forming a first magnetic layer;
 - b. depositing an insulator above the magnetic layer and etching the insulator to expose one or more magnetic layer portions;
 - c. depositing a $\text{Pr}_{1-x}\text{Ca}_x\text{MnO}_3$ (PCMO) layer in an electrically biased sputtering chamber above the insulator and the metal portions, to form one or more self-aligned MRAM cells above the first magnetic layer.
12. The method of claim 11, comprising depositing and patterning an insulator layer between a wafer and the first magnetic layer.
3. The method of claim 1, wherein the electrically biased sputtering chamber comprises facing targets.
114. The method of claim 13, comprising forming via holes to connect the first magnetic layer to circuit on the wafer.
15. The method of claim 14, comprising depositing a magnetic layer above the via holes.
16. The method of claim 13, comprising depositing an adhesion layer above the first magnetic layer.
17. The method of claim 16, comprising performing chemical mechanical polishing on the vias.
18. The method of claim 11, comprising depositing a passivation film.
19. The method of claim 18, comprising performing chemical mechanical polishing on the passivated film.