



(19) **United States**

(12) **Patent Application Publication**

Jung et al.

(10) **Pub. No.: US 2013/0243310 A1**

(43) **Pub. Date: Sep. 19, 2013**

(54) **APPARATUS AND METHOD FOR MEASURING OPTICAL CHARACTERISTICS USING A CAMERA AND A CALIBRATION CHART IMAGED WITH THE CAMERA**

(52) **U.S. Cl.**
CPC *G06K 9/4652* (2013.01)
USPC **382/162**

(76) Inventors: **Wayne D. Jung**, Morton Grove, IL (US);
Russell W. Jung, Morton Grove, IL (US);
Alan R. Loudermilk, Chicago, IL (US)

(57) **ABSTRACT**

(21) Appl. No.: **13/612,123**

(22) Filed: **Sep. 12, 2012**

Related U.S. Application Data

(63) Continuation of application No. 12/661,542, filed on Mar. 17, 2010, now abandoned, which is a continuation of application No. 11/510,494, filed on Aug. 25, 2006, now Pat. No. 7,682,150, which is a continuation of application No. 10/407,624, filed on Apr. 4, 2003, now Pat. No. 7,097,450, which is a continuation of application No. 09/865,801, filed on May 25, 2001, now Pat. No. 6,726,476, which is a continuation of application No. 09/091,170, filed on Jun. 8, 1998, now Pat. No. 6,254,385, filed as application No. PCT/US97/00129 on Jan. 2, 1997.

A method including the determination of color information of an object is disclosed. Data is generated of the object with an image generation device having a field of view. The object and a reference implement having one or more regions of predetermined optical properties are positioned in the field of view of the image generation device. Data is generated of the reference implement, which includes a positional location attribute. Based on the positional location attribute a position of the one or more regions of predetermined optical properties of the reference implement in the field of view of the image generation device is determined by a processing system without operator identification of the position of the reference implement in the field of view of the image generation device. Color information of the object is generated by adjusting the data generated of the object based on the data generated of the reference implement. The color information may include value, chroma and hue information, RGB values, XYZ coordinates, or Lab values. The color information may be transmitted electronically to a remote location. The object may be human skin. The object and the reference implement may be positioned so as to be subject to a substantially corresponding lighting condition.

Publication Classification

(51) **Int. Cl.**
G06K 9/46 (2006.01)

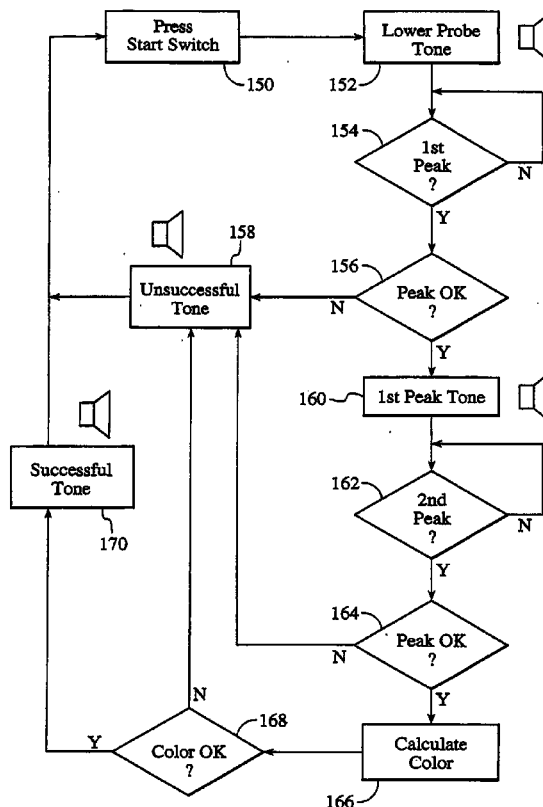

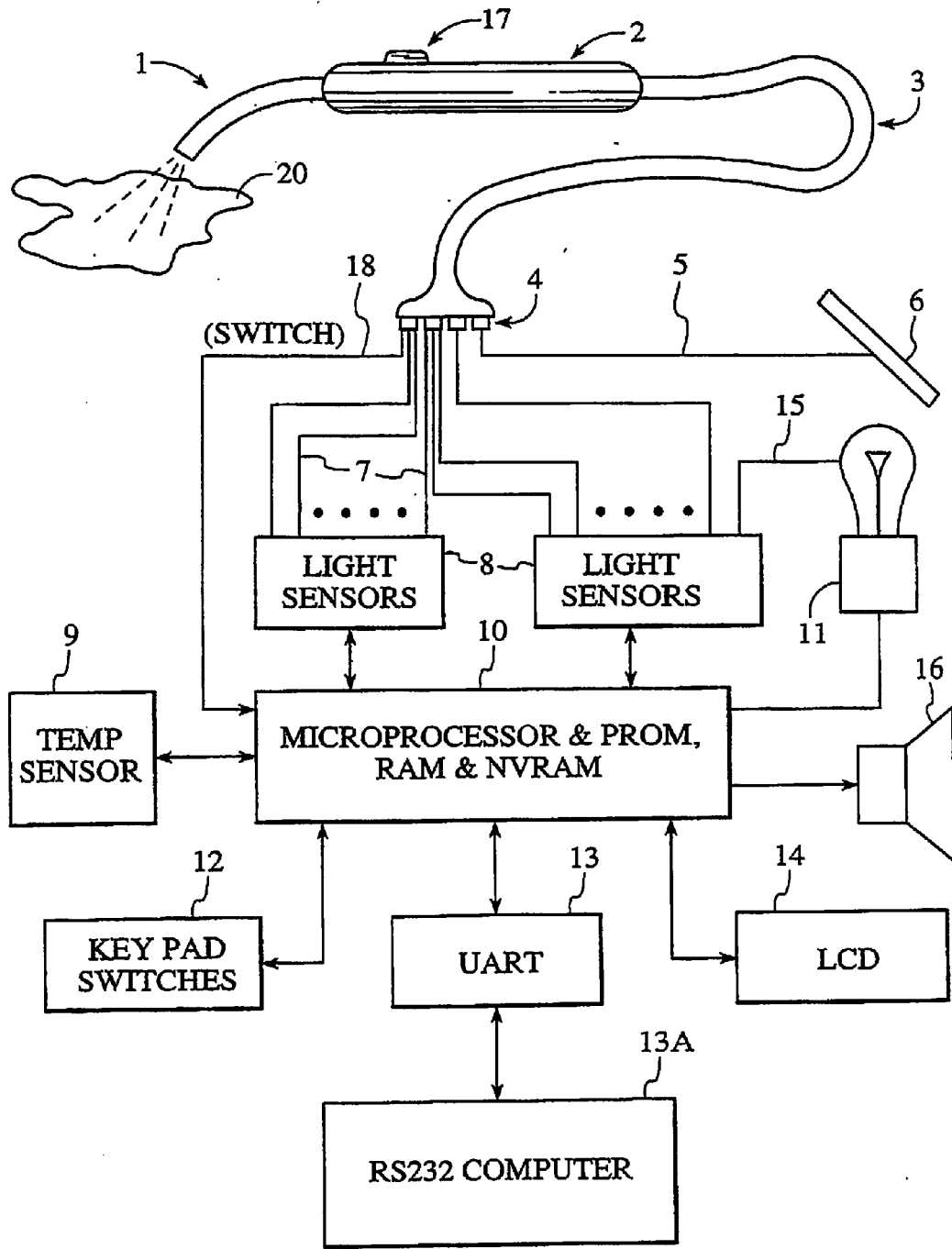
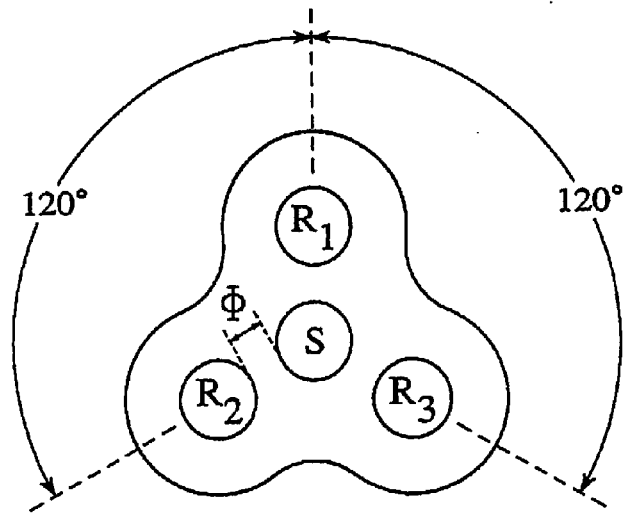

FIG. 1



R - LIGHT RECEIVER FIBER OPTICS
S - LIGHT SOURCE FIBER OPTIC

FIG. 2

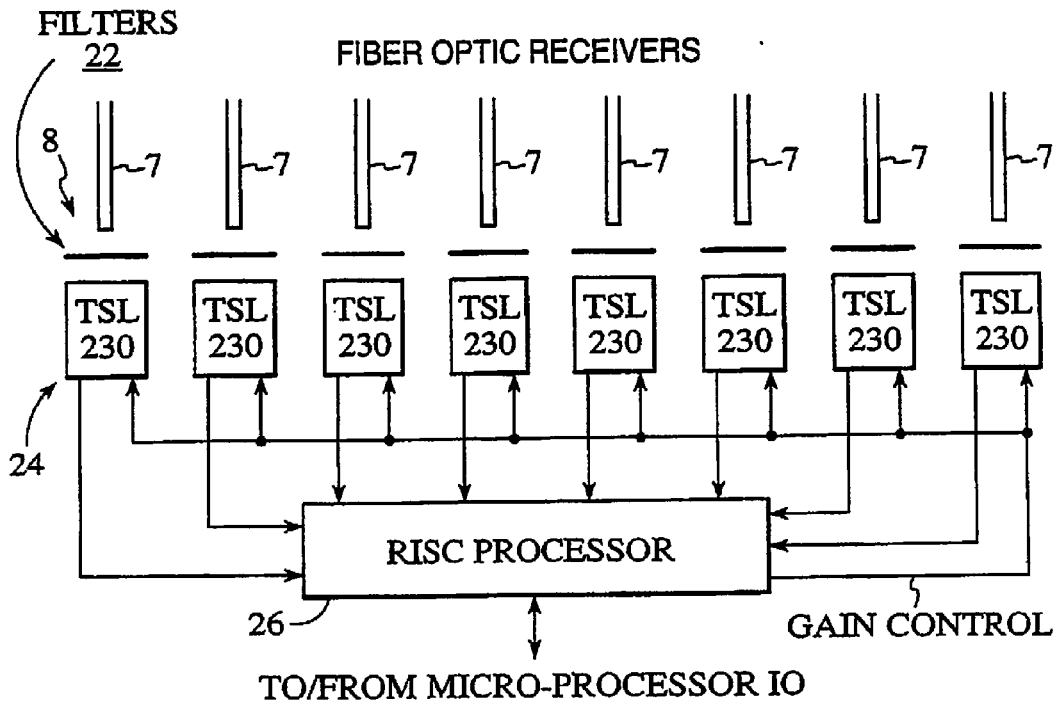

FIG. 3

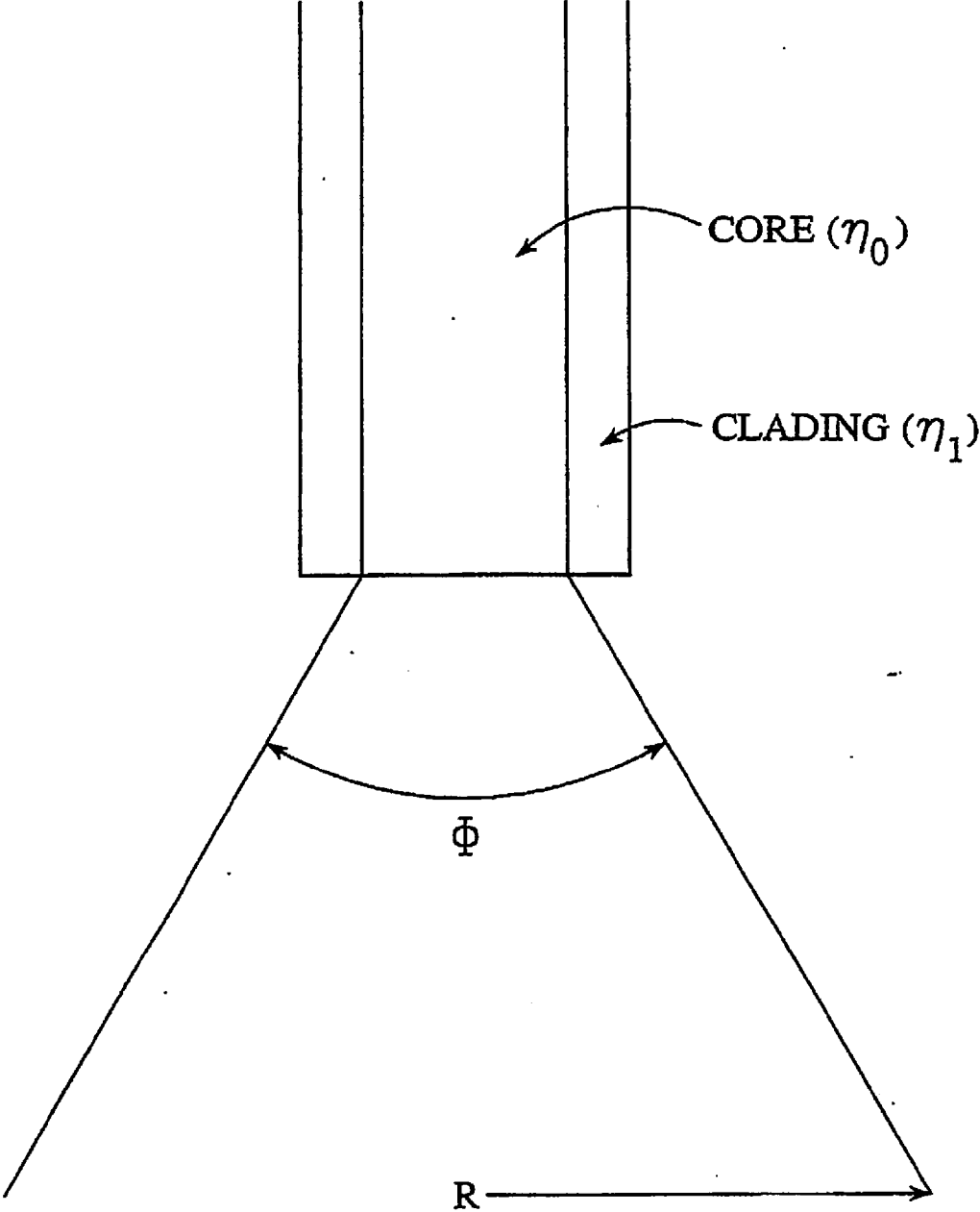

FIG. 4A

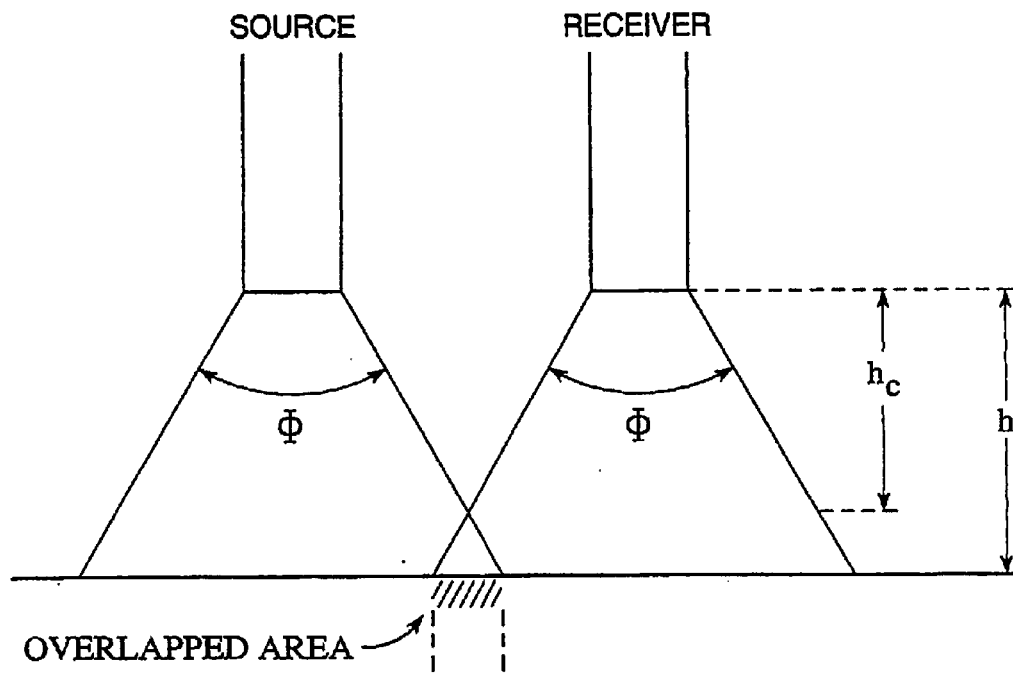

FIG. 4B

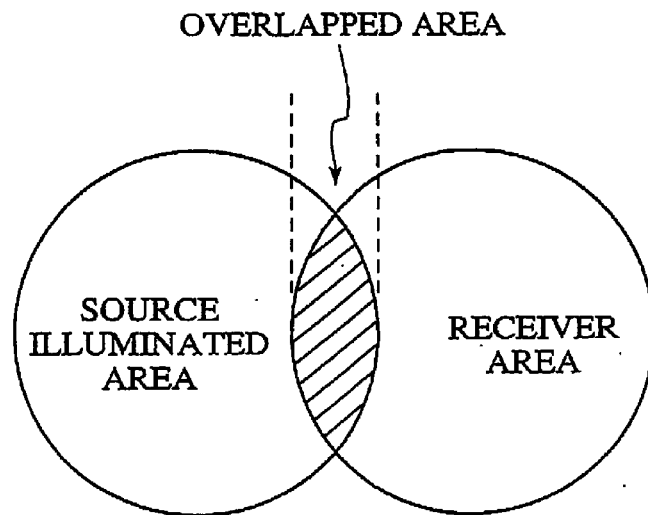

FIG. 4C

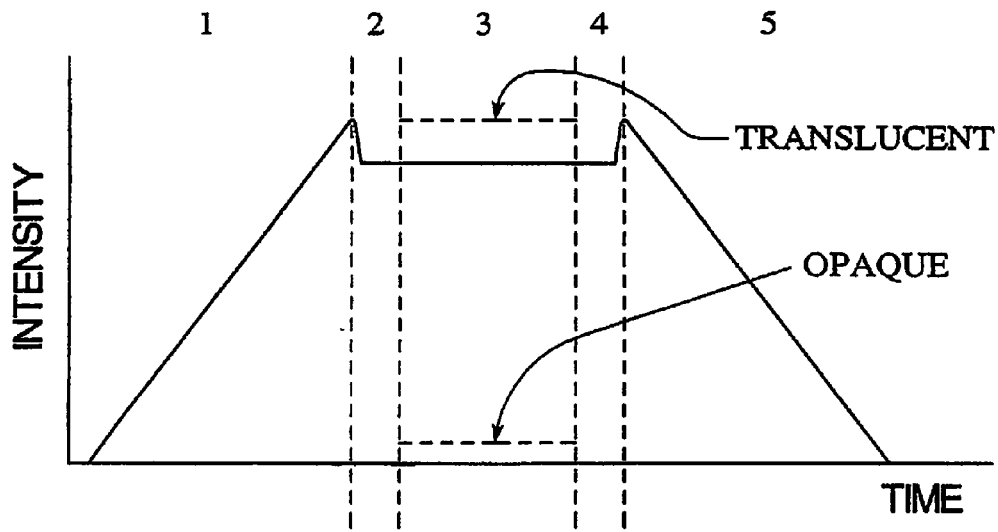

FIG. 5A

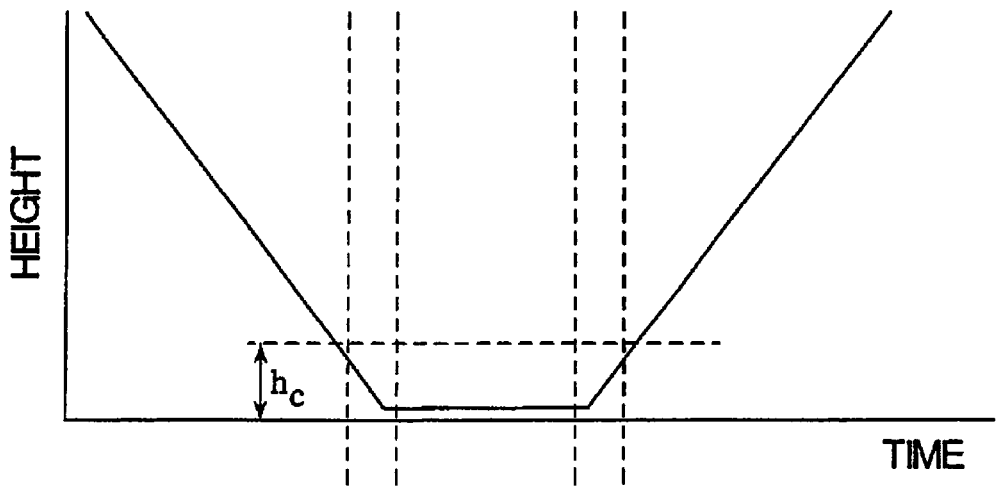
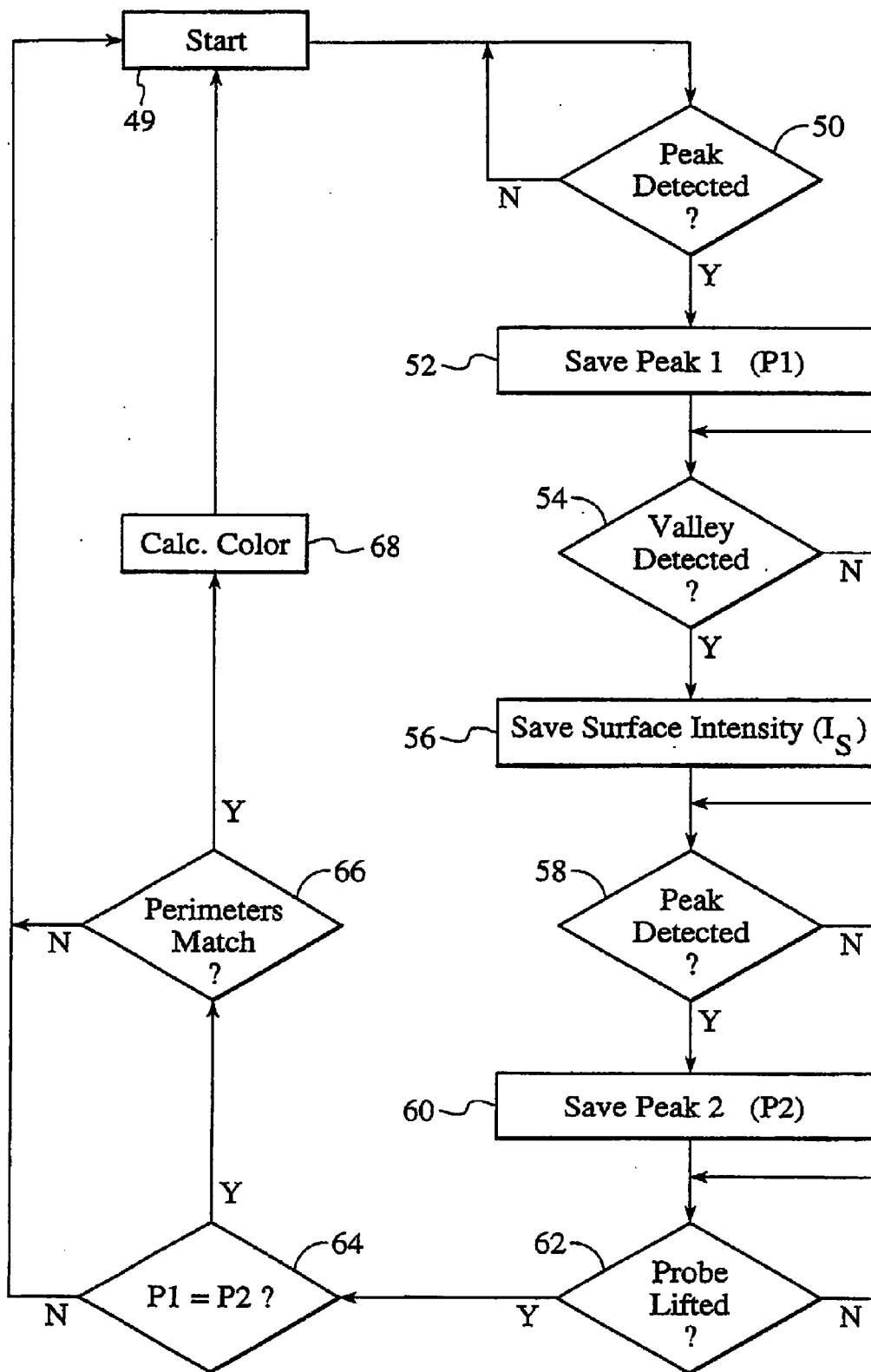

FIG. 5B

FIG. 6



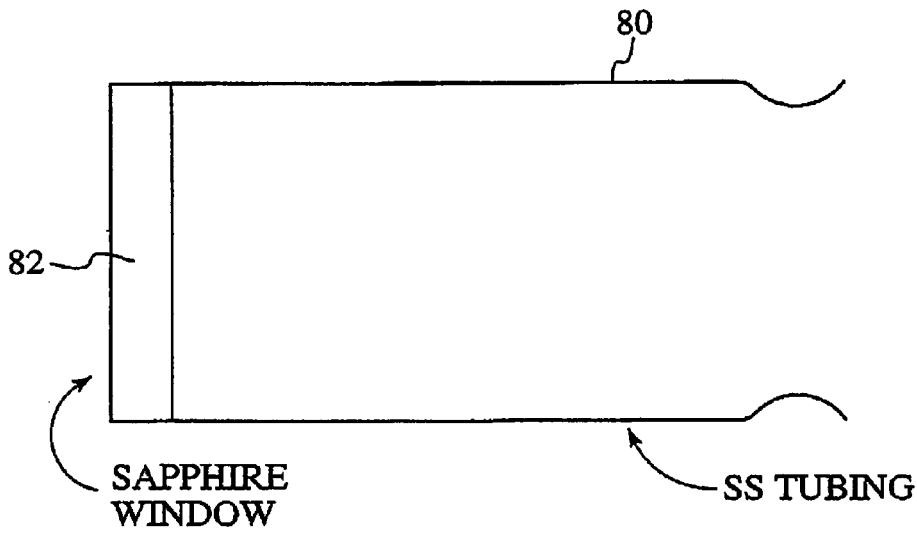

FIG. 7A

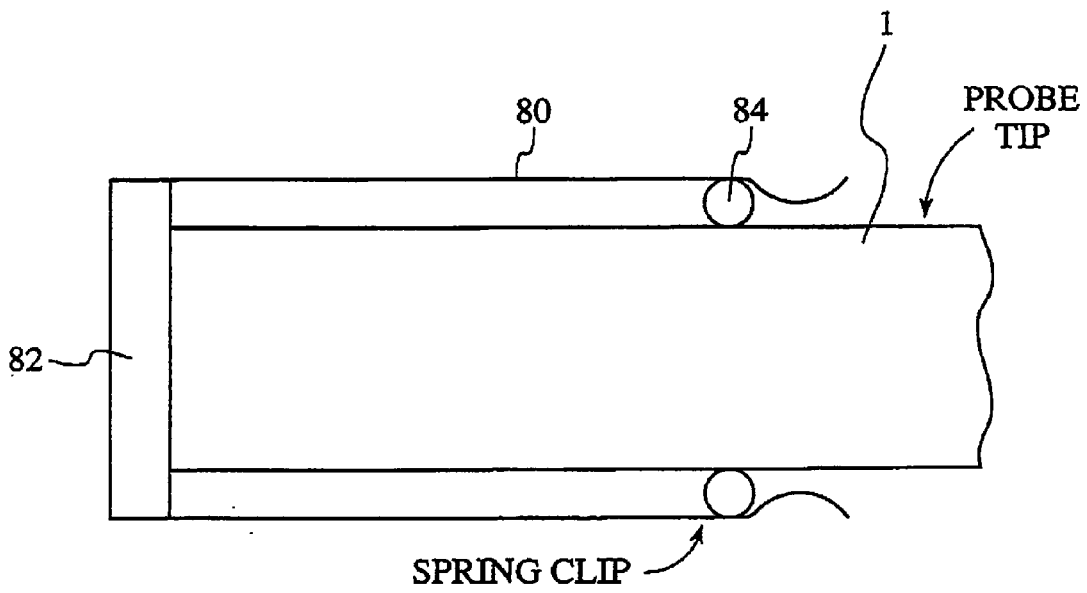

FIG. 7B

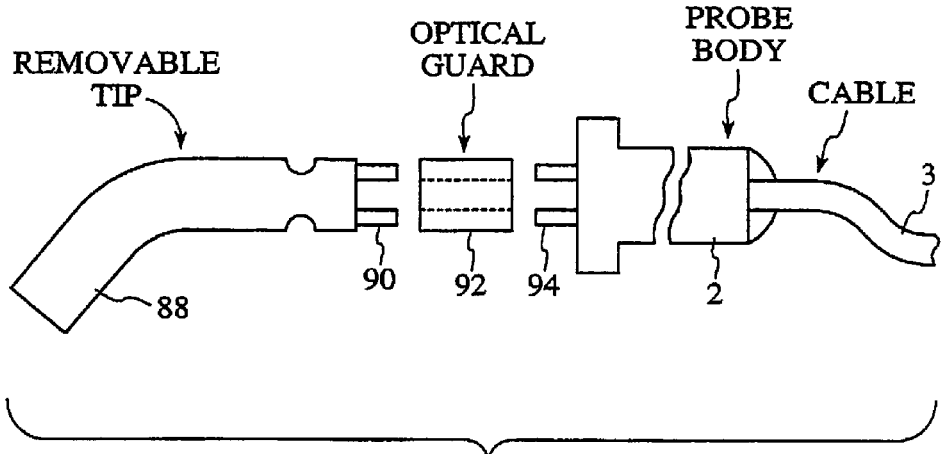

FIG. 8A

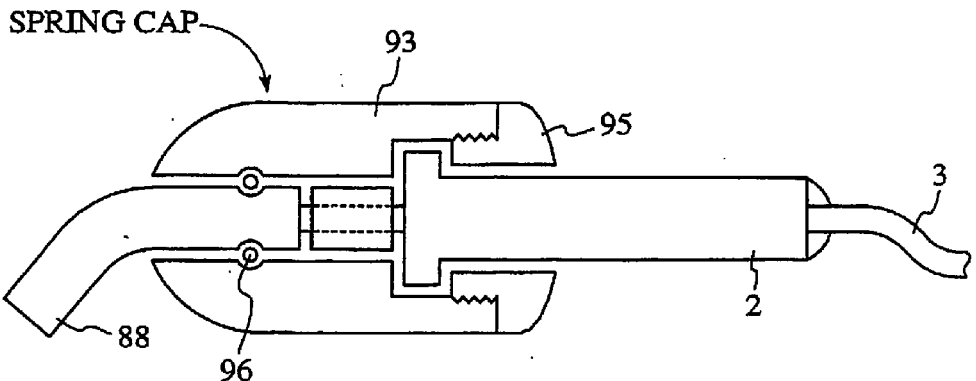
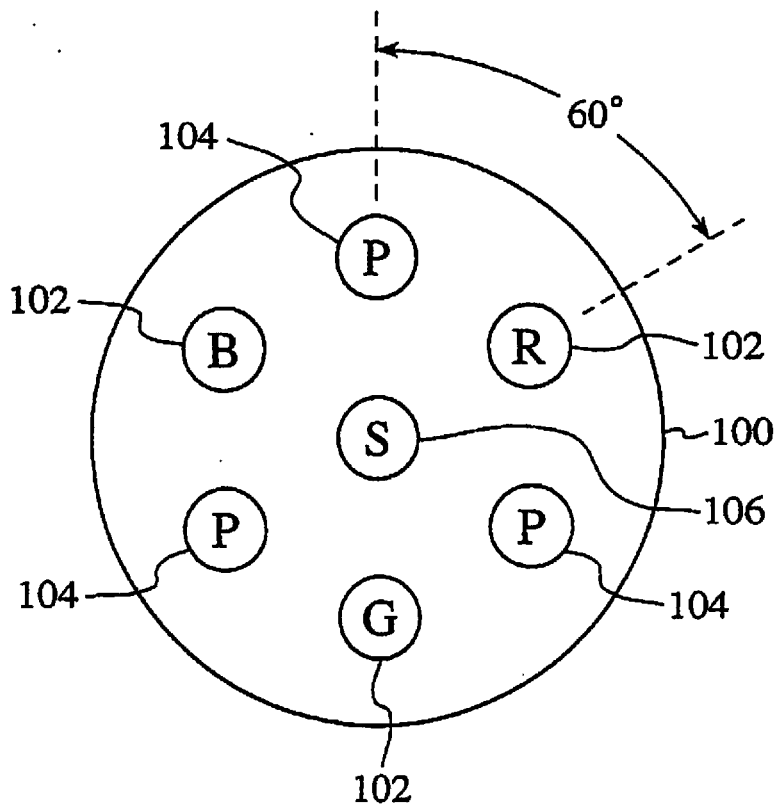

FIG. 8B



S - LIGHT SOURCE FIBER
 R - RED RECEIVER
 G - GREEN RECEIVER
 B - BLUE RECEIVER
 P - NEUTRAL (FULL BAND) RECEIVERS

FIG. 9

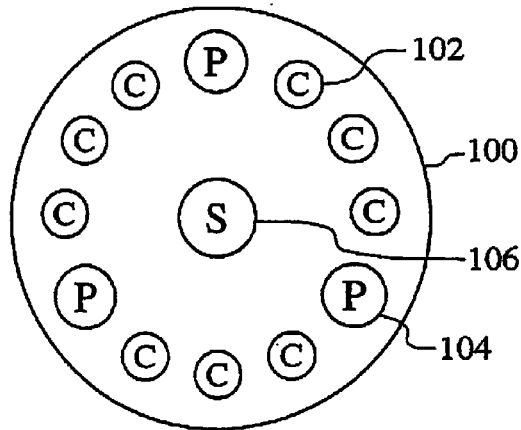

FIG. 10A

S - LIGHT SOURCE FIBER
 P - NEUTRAL (FULL BAND) RECEIVER
 C - COLOR RECEIVER

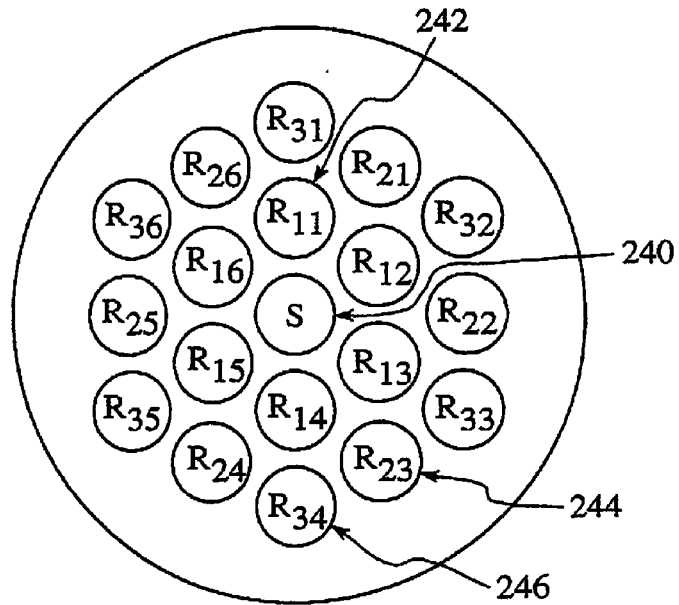

FIG. 10B

S - LIGHT SOURCE FIBER
 R_{1X} - INNER RING RECEIVER FIBER
 R_{2X} - 2nd RING RECEIVER FIBER
 R_{3X} - 3rd RING RECEIVER FIBER

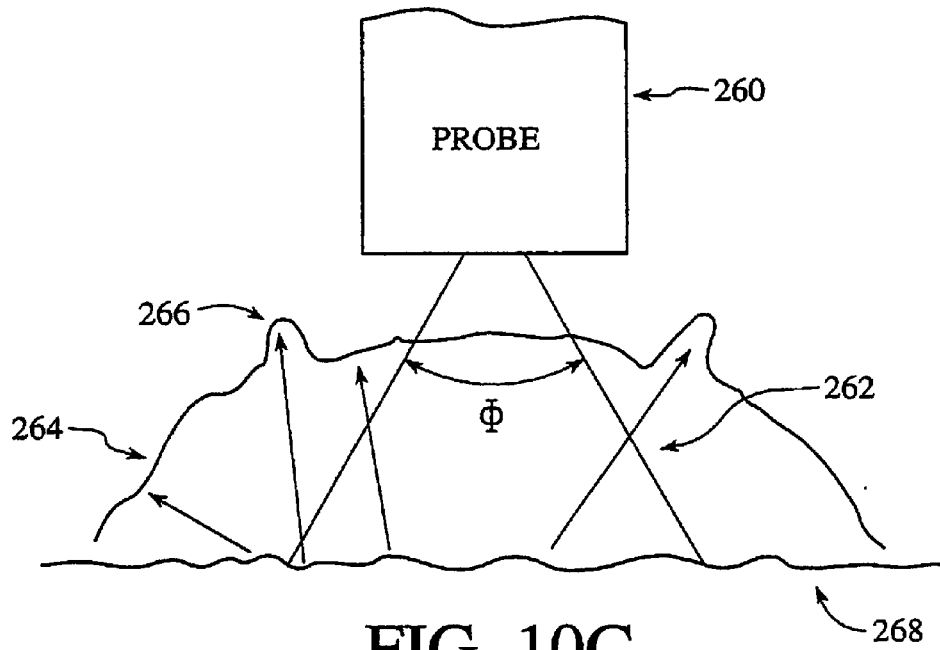

FIG. 10C

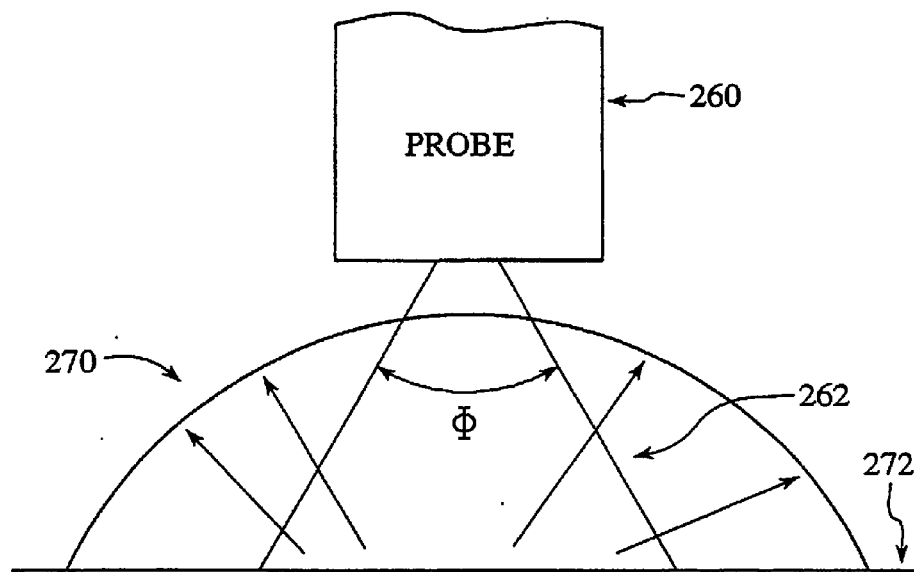

FIG. 10D

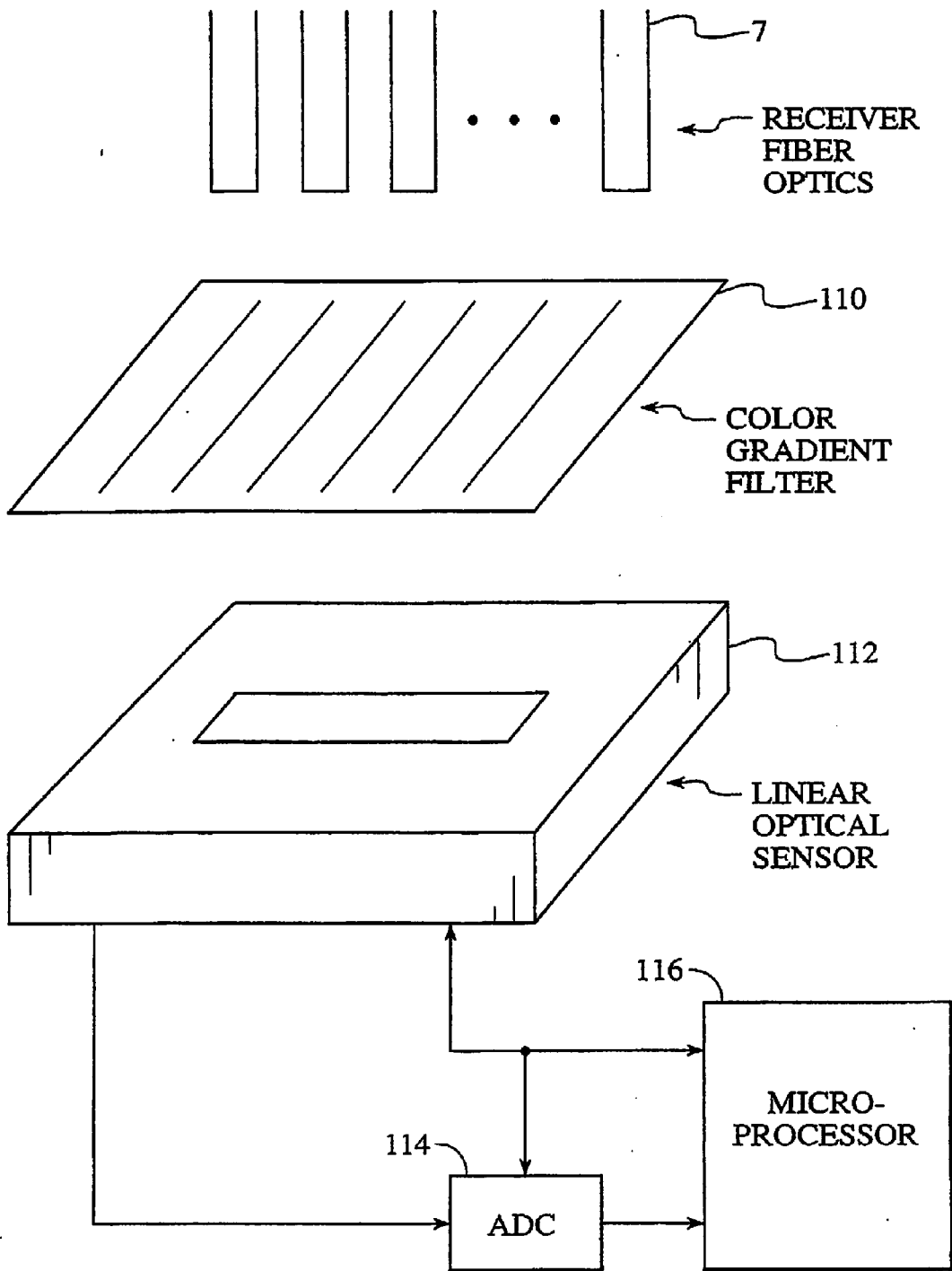

FIG. 11

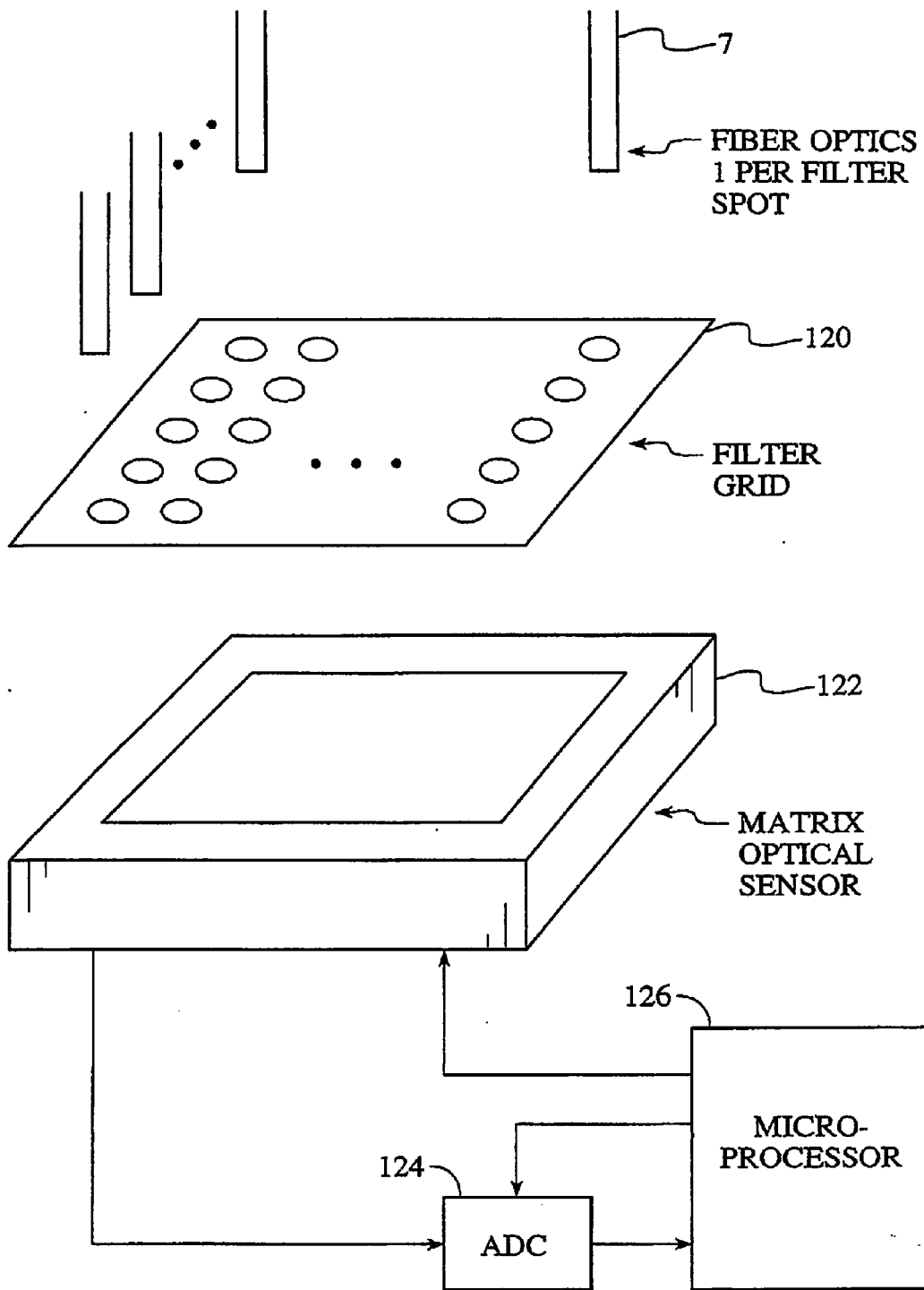

FIG. 12

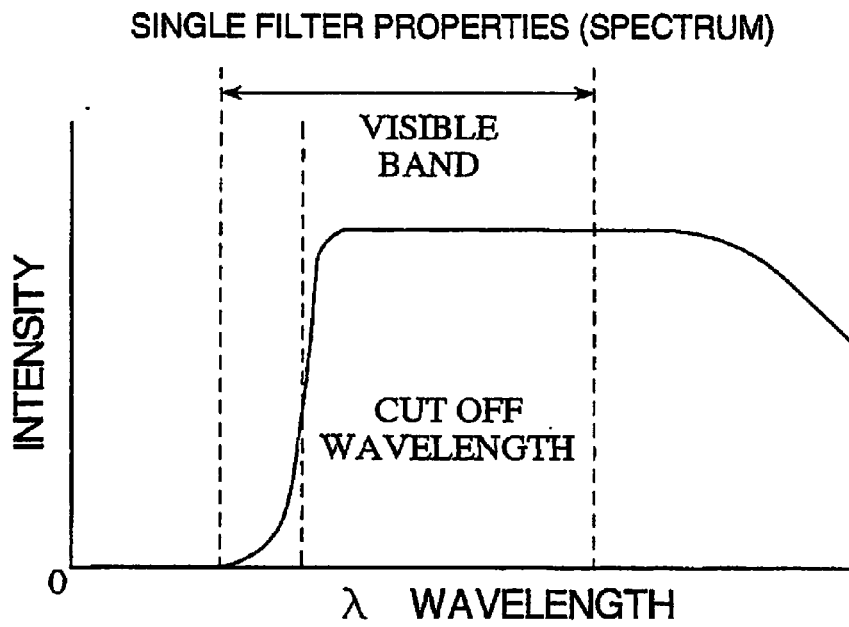

FIG. 13A

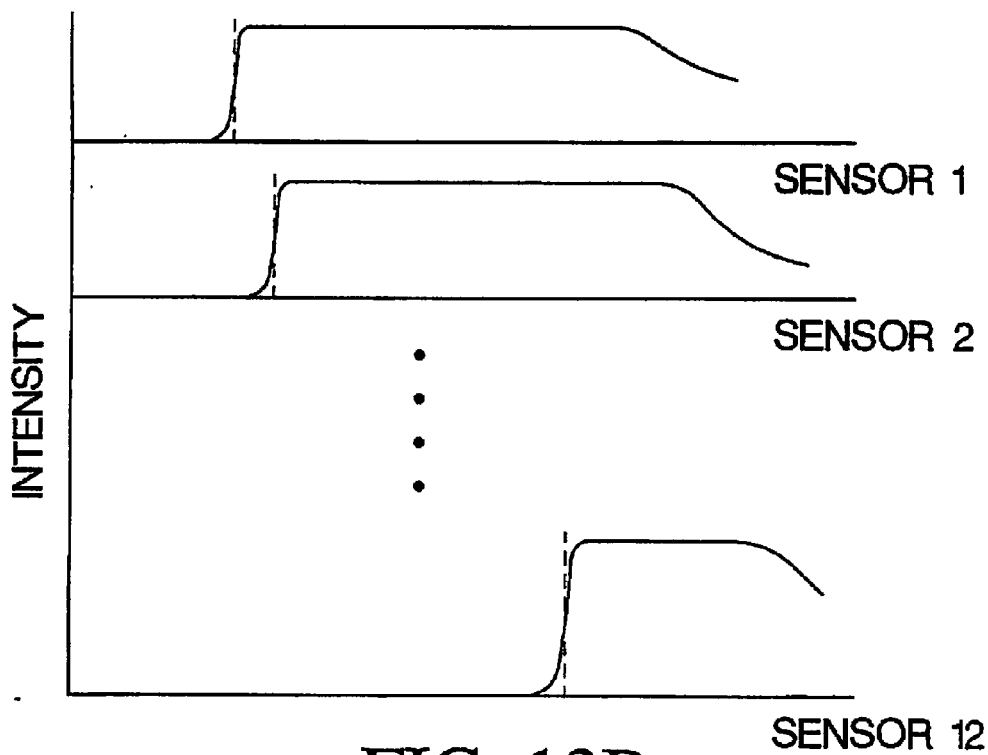

FIG. 13B

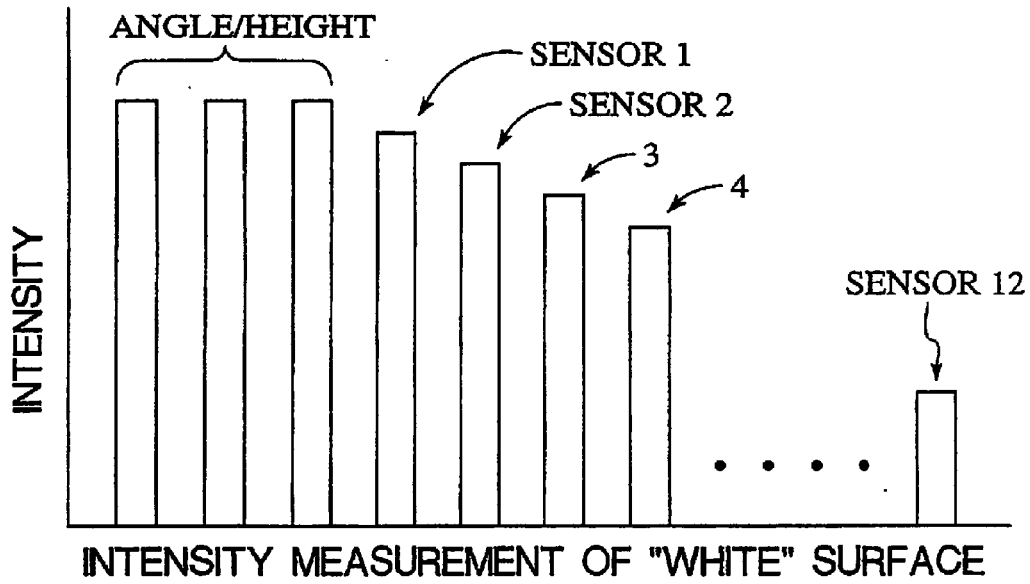

FIG. 14A

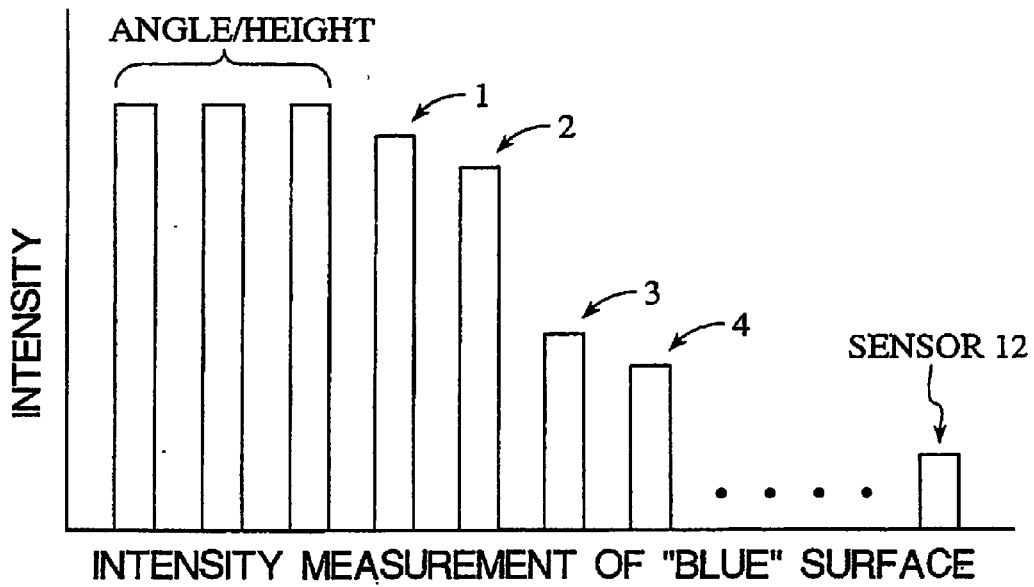

FIG. 14B

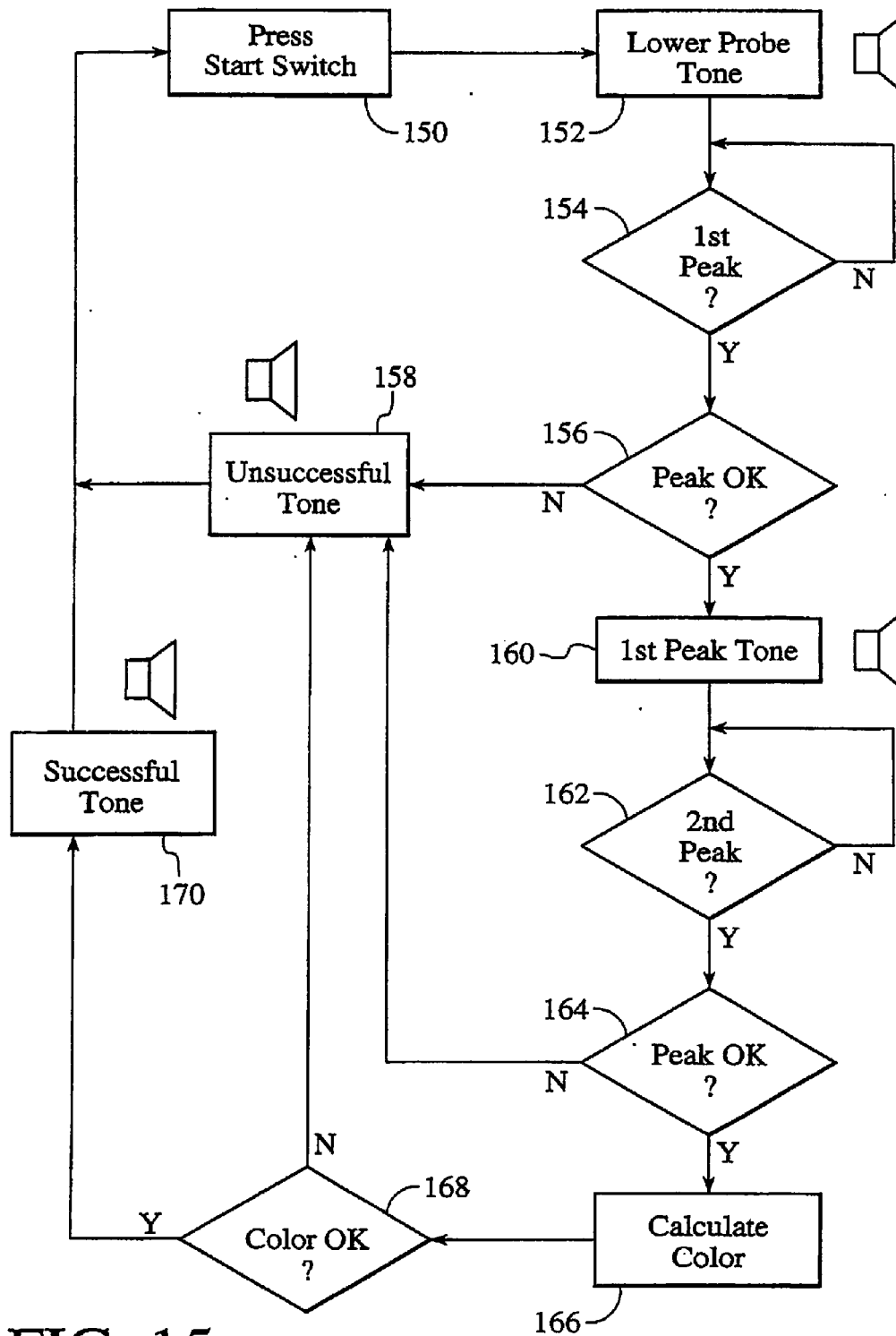

FIG. 15

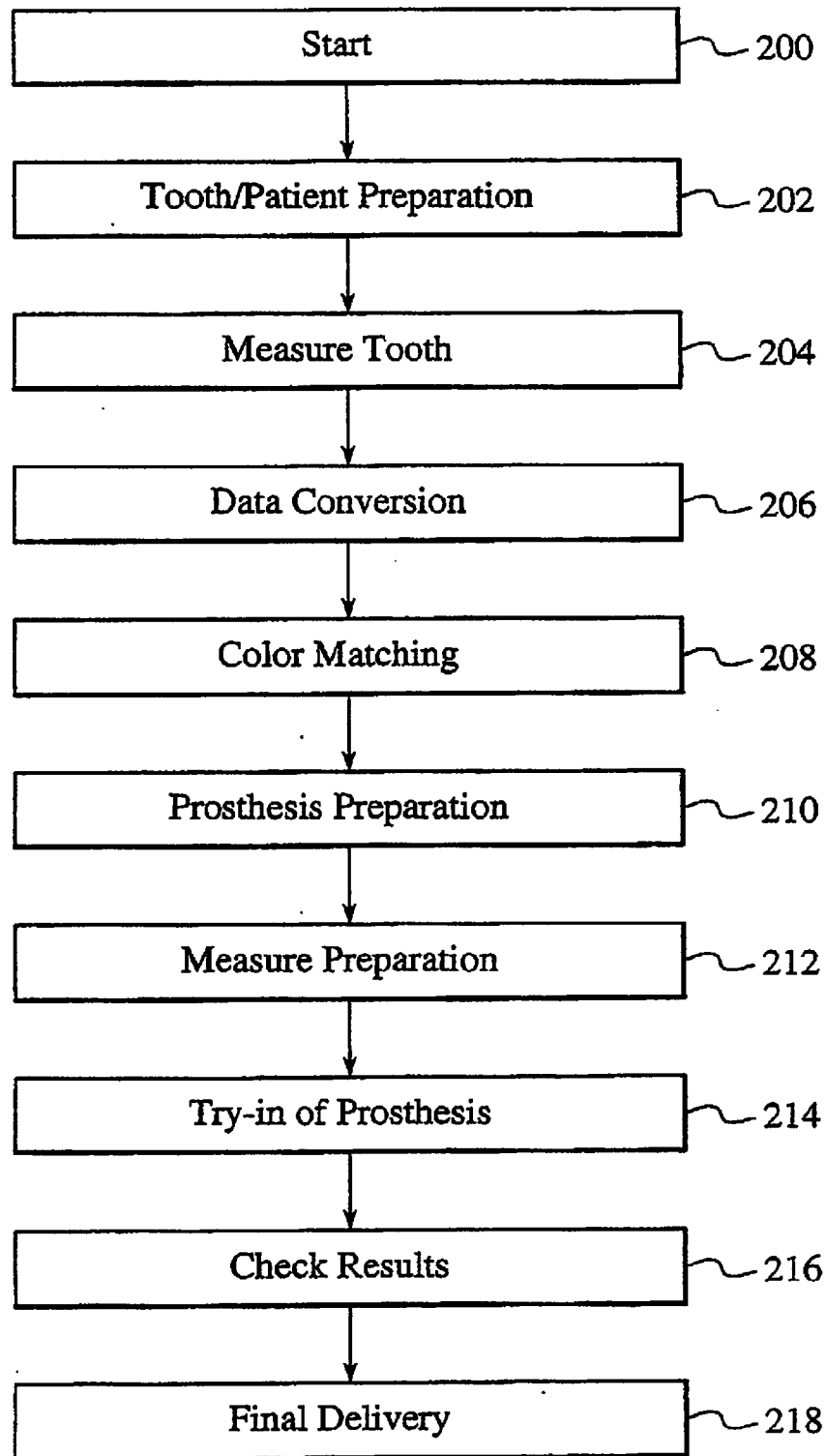

FIG. 16

INTRAORAL POSITIONING DEVICE

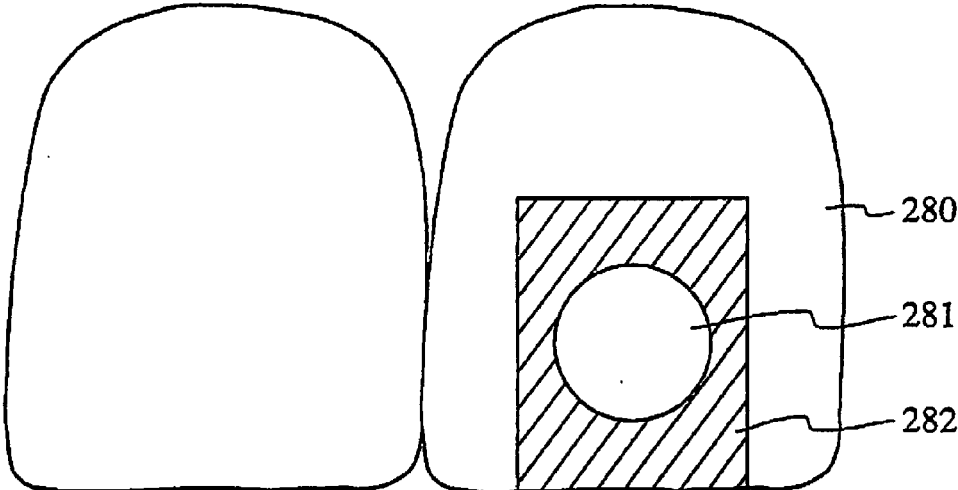

FIG. 17A

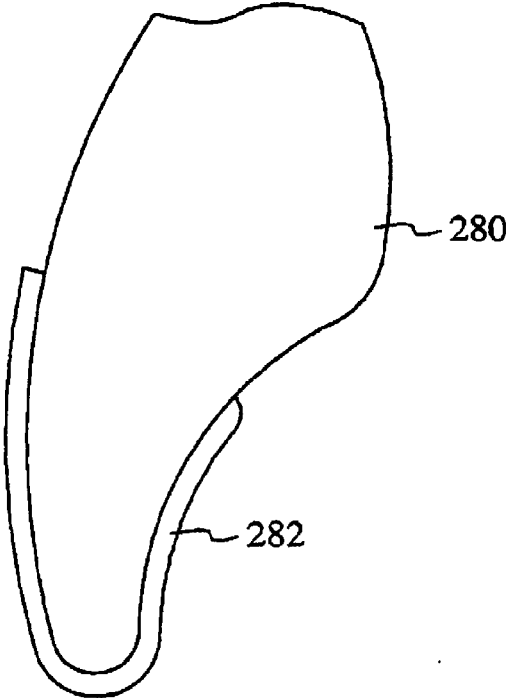

FIG. 17B

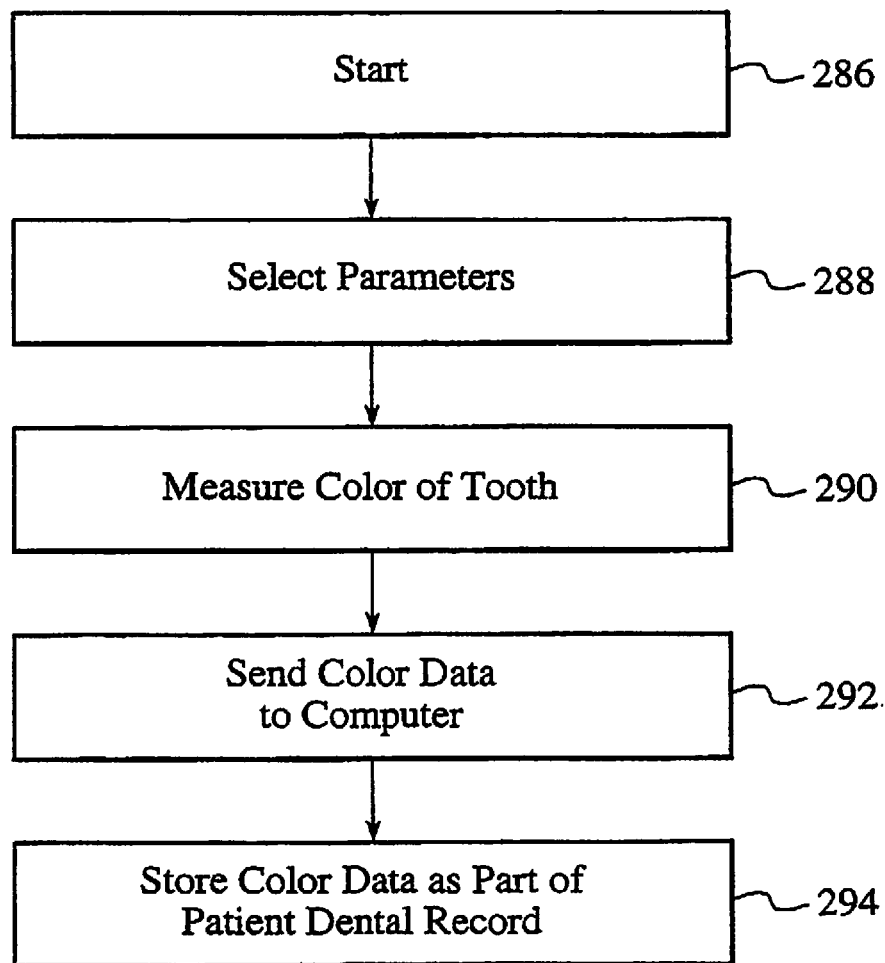

FIG. 18

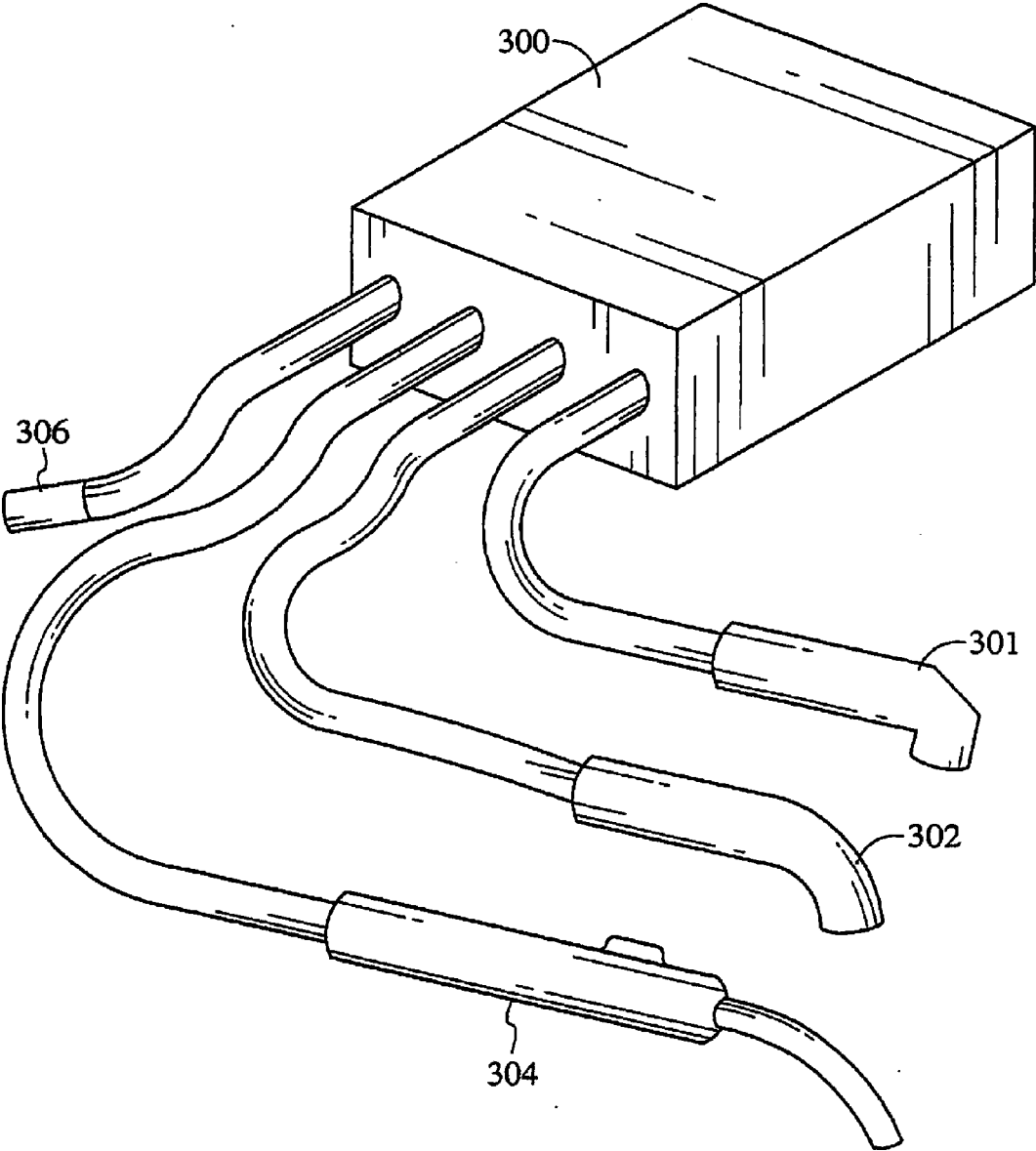

FIG. 19

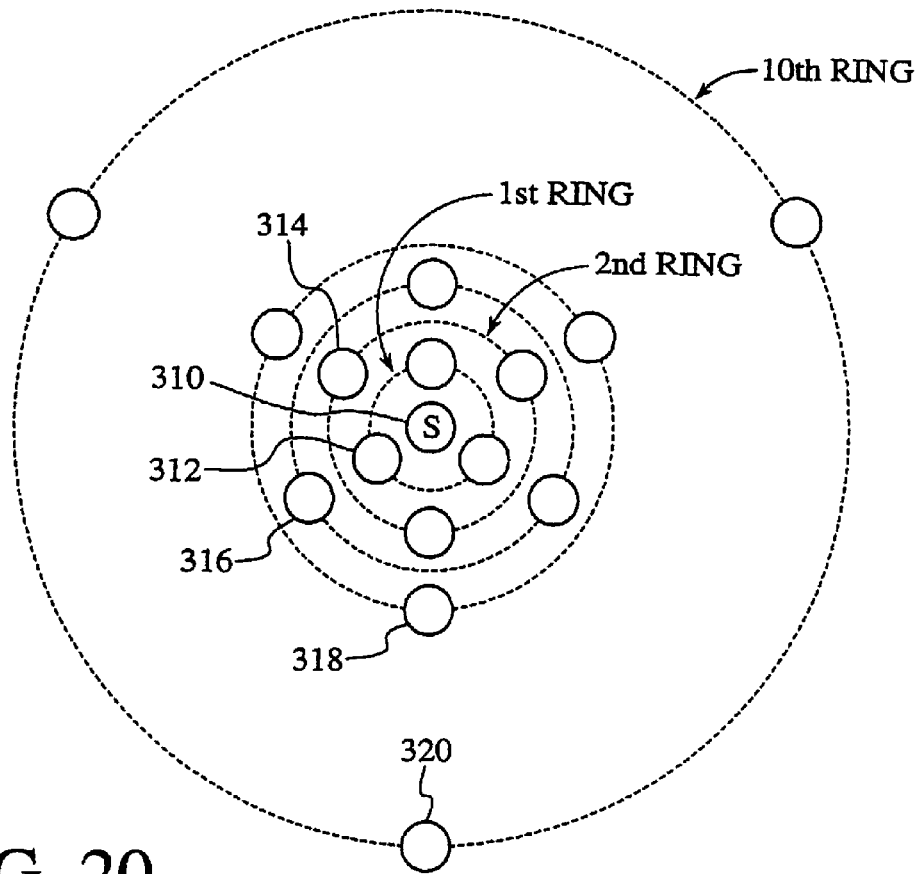

FIG. 20

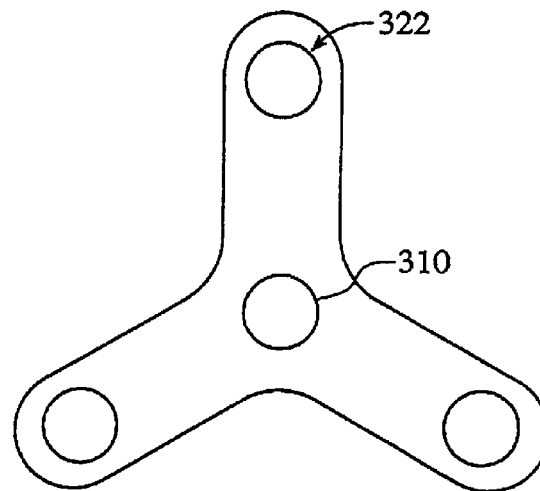

FIG. 21

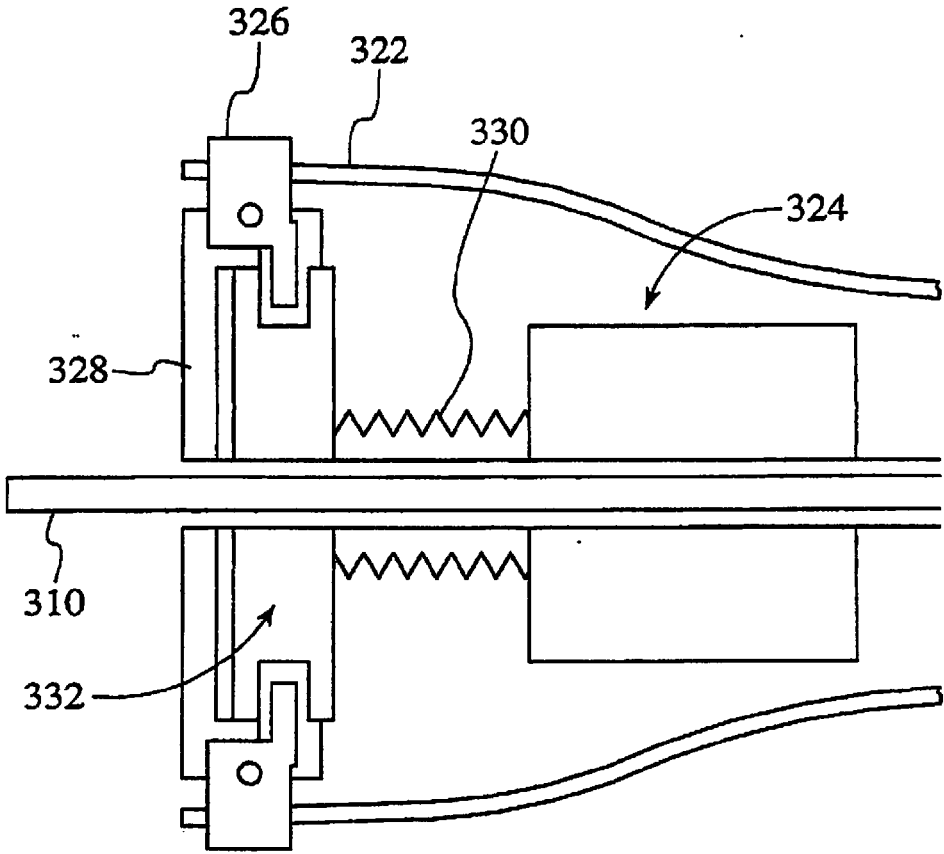

FIG. 22

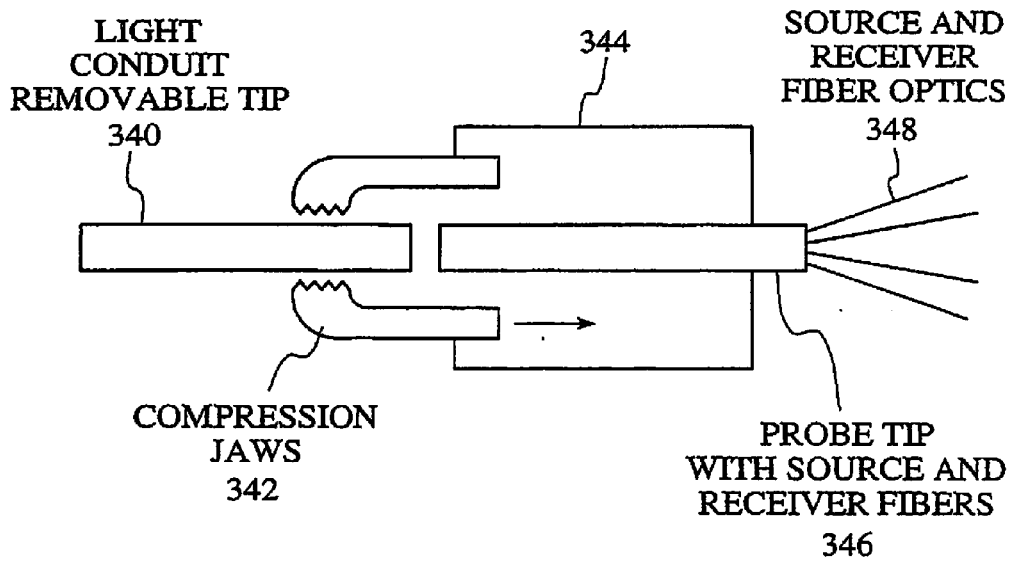

FIG. 23A

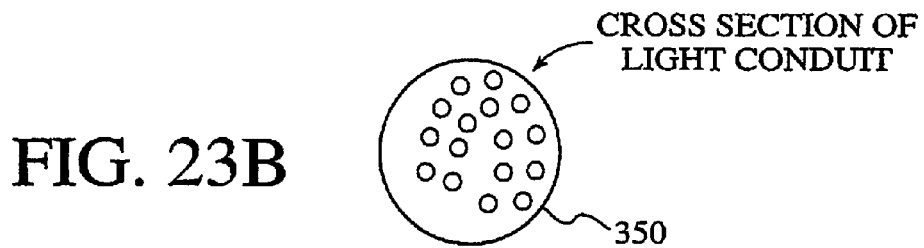

FIG. 23B

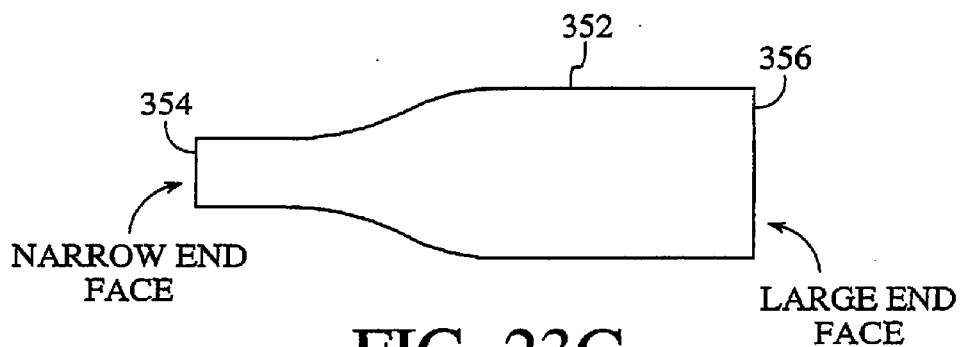

FIG. 23C

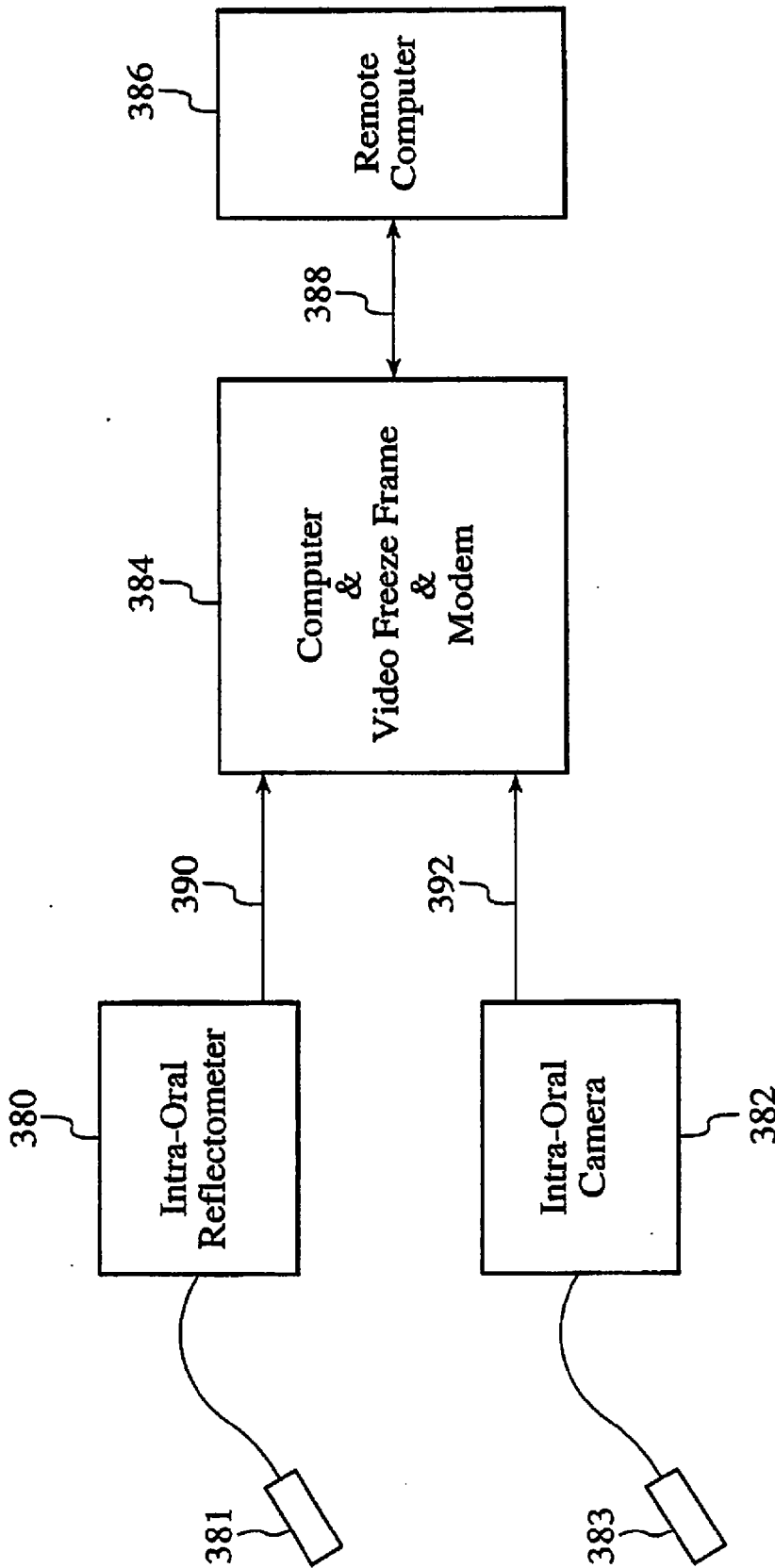

FIG. 24

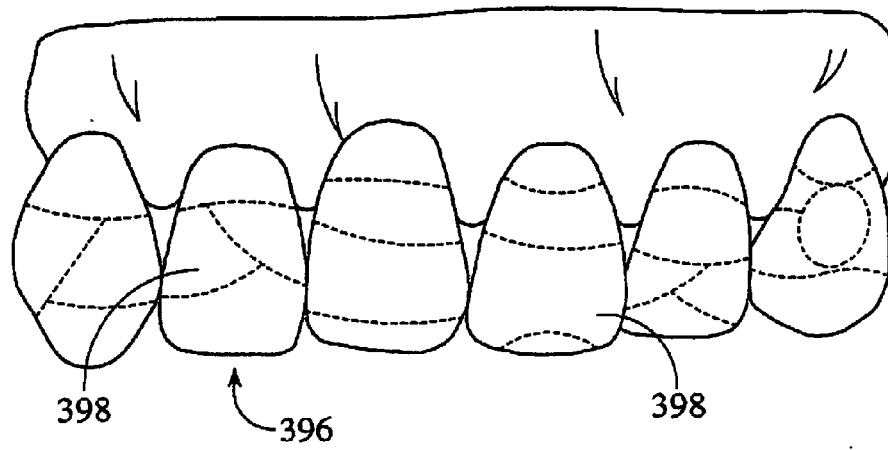

FIG. 25

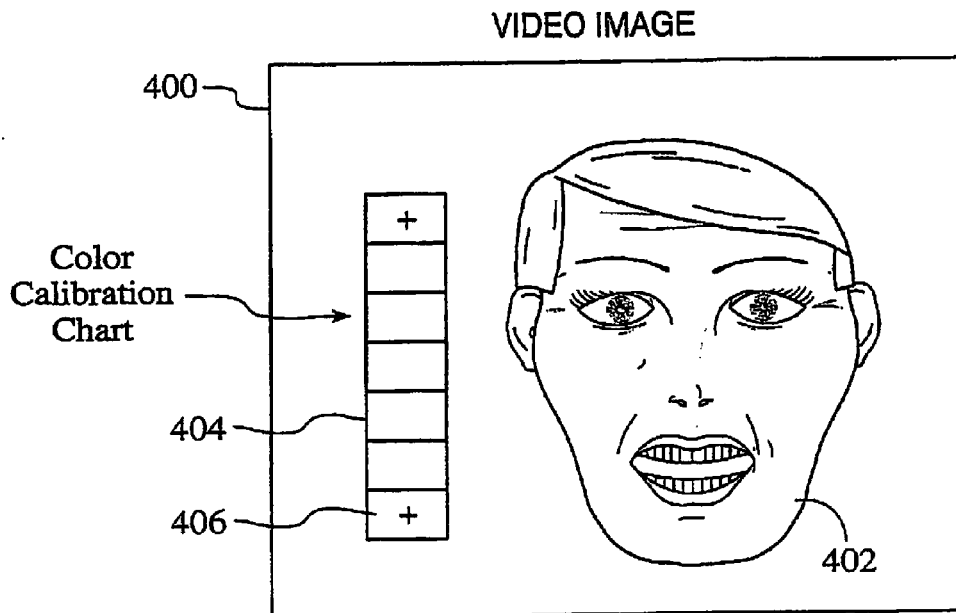

FIG. 26

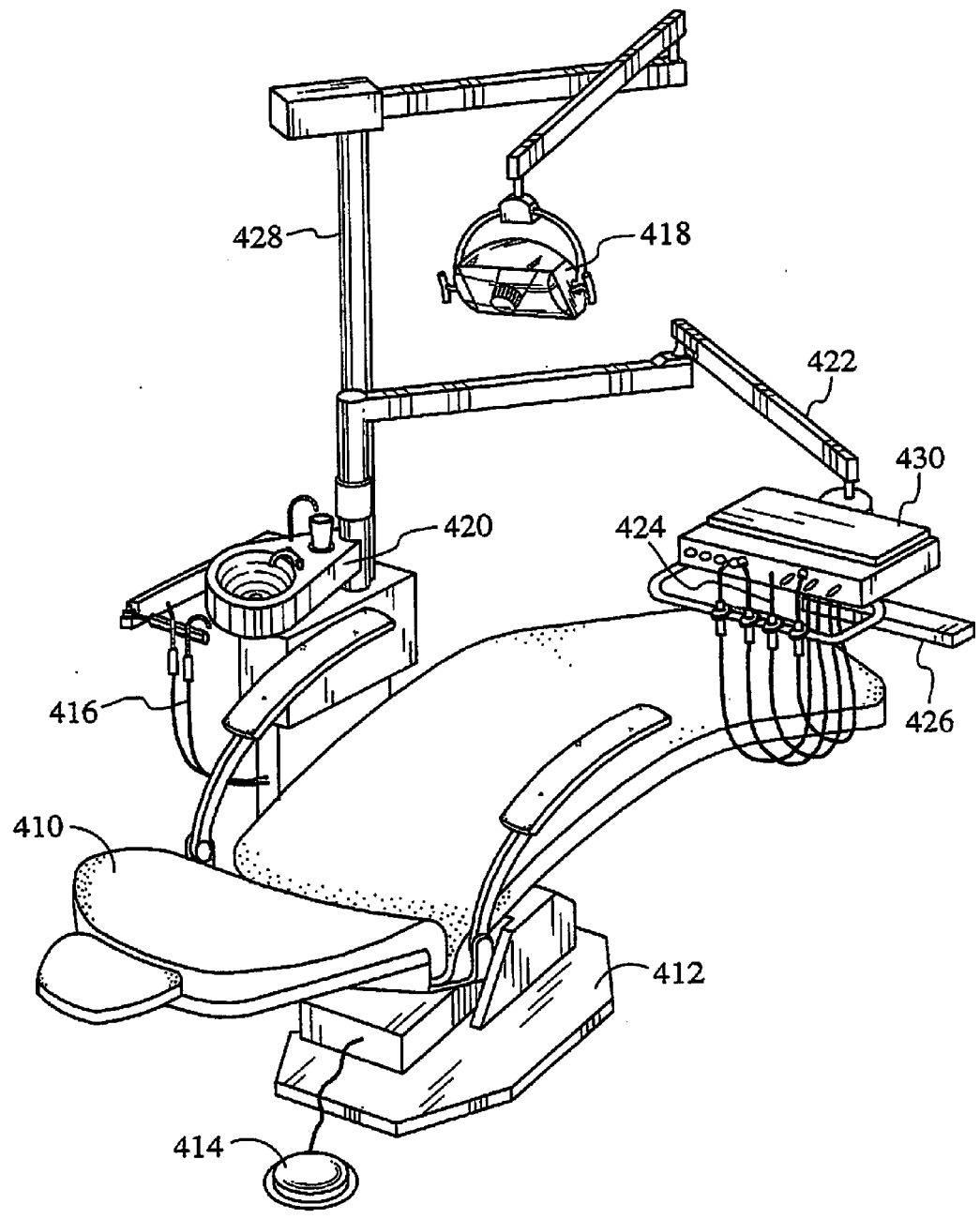

FIG. 27

**APPARATUS AND METHOD FOR
MEASURING OPTICAL CHARACTERISTICS
USING A CAMERA AND A CALIBRATION
CHART IMAGED WITH THE CAMERA**

[0001] This application is a continuation of application Ser. No. 12/661,542, filed Mar. 17, 2010, abandoned, which is a continuation of application Ser. No. 11/510,494, now U.S. Pat. No. 7,682,150, which is a continuation of application Ser. No. 10/407,624, filed Apr. 4, 2003, now U.S. Pat. No. 7,097,450, which is a continuation of application Ser. No. 09/865,801, filed May 25, 2001, now U.S. Pat. No. 6,726,476, which is a continuation of application Ser. No. 09/091,170, filed Jun. 8, 1998, now U.S. Pat. No. 6,254,385, which was the national stage application of PCT/US97/00129.

FIELD OF THE INVENTION

[0002] The present invention relates to devices and methods for measuring optical characteristics such as color of objects such as teeth, and more particularly to devices and methods for measuring the color and other optical characteristics of teeth or other objects or surfaces with a hand-held probe that presents minimal problems with height or angular dependencies. The present invention also relates to devices and methods using a camera and a calibration chart imaged with the camera, as described more particularly, for example, in connection with FIG. 26 hereinafter.

BACKGROUND OF THE INVENTION

[0003] A need has been recognized for devices and methods of measuring the color or other optical characteristics of teeth and other objects in the field of dentistry. Various color measuring devices such as spectrophotometers and colorimeters are known in the art. To understand the limitations of such conventional devices, it is helpful to understand certain principles relating to color. Without being bound by theory, Applicants provide the following discussion. In the discussion herein, reference is made to an "object," etc., and it should be understood that in general such discussion may include teeth as the "object."

[0004] The color of an object determines the manner in which light is reflected from the surface of the object. When light is incident upon an object, the reflected light will vary in intensity and wavelength dependent upon the color of the surface of the object. Thus, a red object will reflect red light with a greater intensity than a blue or a green object, and correspondingly a green object will reflect green light with a greater intensity than a red or blue object.

[0005] One method of quantifying the color of an object is to illuminate it with broad band spectrum or "white" light, and measure the spectral properties of the reflected light over the entire visible spectrum and compare the reflected spectrum with the incident light spectrum. Such instruments typically require a broad band spectrophotometer, which generally are expensive, bulky and relatively cumbersome to operate, thereby limiting the practical application of such instruments.

[0006] For certain applications, the broad band data provided by a spectrophotometer is unnecessary. For such applications, devices have been produced or proposed that quantify color in terms of a numerical value or relatively small set of values representative of the color of the object.

[0007] It is known that the color of an object can be represented by three values. For example, the color of an object can

be represented by red, green and blue values, an intensity value and color difference values, by a CIE value, or by what are known as "tristimulus values" or numerous other orthogonal combinations. It is important that the three values be orthogonal; i.e., any combination of two elements in the set cannot be included in the third element.

[0008] One such method of quantifying the color of an object is to illuminate an object with broad band "white" light and measure the intensity of the reflected light after it has been passed through narrow band filters. Typically three filters (such as red, green and blue) are used to provide tristimulus light values representative of the color of the surface. Yet another method is to illuminate an object with three monochromatic light sources (such as red, green and blue) one at a time and then measure the intensity of the reflected light with a single light sensor. The three measurements are then converted to a tristimulus value representative of the color of the surface. Such color measurement techniques can be utilized to produce equivalent tristimulus values representative of the color of the surface. Generally, it does not matter if a "white" light source is used with a plurality of color sensors (or a continuum in the case of a spectrophotometer), or if a plurality of colored light sources are utilized with a single light sensor.

[0009] There are, however, difficulties with the conventional techniques. When light is incident upon a surface and reflected to a light receiver, the height of the light sensor and the angle of the sensor relative to the surface and to the light source also affect the intensity of the received light. Since the color determination is being made by measuring and quantifying the intensity of the received light for different colors, it is important that the height and angular dependency of the light receiver be eliminated or accounted for in some manner.

[0010] One method for eliminating the height and angular dependency of the light source and receiver is to provide a fixed mounting arrangement where the light source and receiver are stationary and the object is always positioned and measured at a preset height and angle. The fixed mounting arrangement greatly limits the applicability of such a method. Another method is to add mounting feet to the light source and receiver probe and to touch the object with the probe to maintain a constant height and angle. The feet in such an apparatus must be wide enough apart to insure that a constant angle (usually perpendicular) is maintained relative to the object. Such an apparatus tends to be very difficult to utilize on small objects or on objects that are hard to reach, and in general does not work satisfactorily in measuring objects with curved surfaces. Such devices are particularly difficult to implement in the field of dentistry.

[0011] The use of color measuring devices in the field of dentistry has been proposed. In modern dentistry, the color of teeth typically are quantified by manually comparing a patient's teeth with a set of "shade guides." There are numerous shade guides available for dentists in order to properly select the desired color of dental prosthesis. Such shade guides have been utilized for decades and the color determination is made subjectively by the dentist by holding a set of shade guides next to a patient's teeth and attempting to find the best match. Unfortunately, however, the best match often is affected by the ambient light color in the dental operatory and the surrounding color of the patient's makeup or clothing and by the fatigue level of the dentist. In addition, such pseudo trial and error methods based on subjective matching with existing industry shade guides for forming dental prostheses,

fillings and the like often result in unacceptable color matching, with the result that the prosthesis needs to be remade, leading to increased costs and inconvenience to the patient, dental professional and/or prosthesis manufacturer.

[0012] Similar subjective color quantification also is made in the paint industry by comparing the color of an object with a paint reference guide. There are numerous paint guides available in the industry and the color determination also often is affected by ambient light color, user fatigue and the color sensitivity of the user. Many individuals are color insensitive (color blind) to certain colors, further complicating color determination.

[0013] While a need has been recognized in the field of dentistry, however, the limitations of conventional color/optical measuring techniques typically restrict the utility of such techniques. For example, the high cost and bulkiness of typical broad band spectrometers, and the fixed mounting arrangements or feet required to address the height and angular dependency, often limit the applicability of such conventional techniques.

[0014] Moreover, another limitation of such conventional methods and devices are that the resolution of the height and angular dependency problems typically require contact with the object being measured. In certain applications, it may be desirable to measure and quantify the color of an object with a small probe that does not require contact with the surface of the object. In certain applications, for example, hygienic considerations make such contact undesirable. In the other applications, contact with the object can mar the surface (such as if the object is coated in some manner) or otherwise cause undesirable effects.

[0015] In summary, there is a need for a low cost, hand-held probe of small size that can reliably measure and quantify the color and other optical characteristics of an object without requiring physical contact with the object, and also a need for methods based on such a device in the field of dentistry and other applications.

SUMMARY OF THE INVENTION

[0016] In accordance with the present invention, devices and methods are provided for measuring the color and other optical characteristics of objects such as teeth, reliably and with minimal problems of height and angular dependence. A handheld probe is utilized in the present invention, with the handheld probe containing a number of fiber optics in certain preferred embodiments. Light is directed from one (or more) light source(s) towards the object/tooth to be measured, which in certain preferred embodiments is a central light source fiber optic (other light sources and light source arrangements also may be utilized). Light reflected from the object is detected by a number of light receivers. Included in the light receivers (which may be light receiver fiber optics) are a plurality of perimeter receivers (which may be light receiver fiber optics, etc.). In certain preferred embodiments, three perimeter fiber optics are utilized in order to take measurements at a desired, and predetermined height and angle, thereby minimizing height and angular dependency problems found in conventional methods. In certain embodiments, the present invention also may measure translucence and fluorescence characteristics of the object/tooth being measured, as well as surface texture and/or other optical or surface characteristics.

[0017] The present invention may include constituent elements of a broad band spectrophotometer, or, alternatively,

may include constituent elements of a tristimulus type colorimeter. The present invention may employ a variety of color measuring devices in order to measure color in a practical, reliable and efficient manner, and in certain preferred embodiments includes a color filter array and a plurality of color sensors. A microprocessor is included for control and calculation purposes. A temperature sensor is included to measure temperature in order to detect abnormal conditions and/or to compensate for temperature effects of the filters or other components of the system. In addition, the present invention may include audio feedback to guide the operator in making color/optical measurements, as well as one or more display devices for displaying control, status or other information.

[0018] With the present invention, color/optical measurements of teeth or the like may be made with a handheld probe in a practical and reliable manner, essentially free of height and angular dependency problems, without resorting to fixtures, feet or other undesirable mechanical arrangements for fixing the height and angle of the probe with respect to the object/tooth. In addition, the present invention includes methods of using such color measurement data to implement processes for forming dental prostheses and the like, as well as methods for keeping such color and/or other data as part of a patient record database.

[0019] Accordingly, it is an object of the present invention to address limitations of conventional color/optical measuring techniques.

[0020] It is another object of the present invention to provide a method and device useful in measuring the color or other optical characteristics of teeth or other objects or surfaces with a hand-held probe of practical size that does not require contact with the object or surface.

[0021] It is a further object of the present invention to provide a color/optical measurement probe and method that does not require fixed position mechanical mounting, feet or other mechanical impediments.

[0022] It is yet another object of the present invention to provide a probe and method useful for measuring color or other optical characteristics that may be utilized with a probe simply placed near the surface to be measured.

[0023] It is a still further object of the present invention to provide a probe and method that are capable of determining translucency characteristics of the object being measured.

[0024] It is a further object of the present invention to provide a probe and method that are capable of determining surface texture characteristics of the object/tooth being measured.

[0025] It is a still further object of the present invention to provide a probe and method that are capable of determining fluorescence characteristics of the object/tooth being measured.

[0026] It is another object of the present invention to provide a probe and method that can measure the area of a small spot singularity, or that also can measure the color of irregular shapes by moving the probe over an area and integrating the color of the entire area.

[0027] It is a further object of the present invention to provide a method of measuring the color of teeth and preparing dental prostheses, dentures, intraoral tooth-colored fillings or other materials.

[0028] It is yet another object of the present invention to provide a method and apparatus that minimizes contamination problems, while providing a reliable and expedient man-

ner in which to measure teeth and prepare dental prostheses, dentures, intraoral tooth-colored fillings or other materials.

[0029] It is an object of the present invention to provide methods of using measured data to implement processes for forming dental prostheses and the like, as well as methods for keeping such measurement and/or other data as part of a patient record database.

[0030] It also is an object of the present invention to provide probes and methods for measuring optical characteristics with a probe that is held substantially stationary with respect to the object or tooth being measured.

[0031] Finally, it is an object of the present invention to provide probes and methods for measuring optical characteristics with a probe that may have a removable tip or shield that may be removed for cleaning, disposed after use or the like

BRIEF DESCRIPTION OF THE DRAWINGS

[0032] The present invention may be more fully understood by a description of certain preferred embodiments in conjunction with the attached drawings in which:

[0033] FIG. 1 is a diagram illustrating a preferred embodiment of the present invention;

[0034] FIG. 2 is a diagram illustrating a cross section of a probe in accordance with a preferred embodiment of the present invention;

[0035] FIG. 3 is a diagram illustrating an arrangement of fiber optic receivers and sensors utilized with a preferred embodiment of the present invention;

[0036] FIGS. 4A to 4C illustrate certain geometric considerations of fiber optics;

[0037] FIGS. 5A and 5B illustrate the light amplitude received by fiber optic light receivers as a function of height from an object;

[0038] FIG. 6 is a flow chart illustrating a color measuring method in accordance with an embodiment of the present invention;

[0039] FIGS. 7A and 7B illustrate a protective cap that may be used with certain embodiments of the present invention;

[0040] FIGS. 8A and 8B illustrate removable probe tips that may be used with certain embodiments of the present invention;

[0041] FIG. 9 illustrates a fiber optic bundle in accordance with another preferred embodiment of the present invention;

[0042] FIGS. 10A, 10B, 10C and 10D illustrate and describe other fiber optic bundle configurations that may be used in accordance with yet other preferred embodiments of the present invention;

[0043] FIG. 11 illustrates a linear optical sensor array that may be used in certain embodiments of the present invention;

[0044] FIG. 12 illustrates a matrix optical sensor array that may be used in certain embodiments of the present invention;

[0045] FIGS. 13A and 13B illustrate certain optical properties of a filter array that may be used in certain embodiments of the present invention;

[0046] FIGS. 14A and 14B illustrate examples of received light intensities of receivers used in certain embodiments of the present invention;

[0047] FIG. 15 is a flow chart illustrating audio tones that may be used in certain preferred embodiments of the present invention;

[0048] FIG. 16 is a flow chart illustrating a dental prosthesis manufacturing method in accordance with a preferred embodiment of the present invention;

[0049] FIGS. 17A and 17B illustrate a positioning implement used in certain embodiments of the present invention;

[0050] FIG. 18 is a flow chart illustrating a patient database method in accordance with certain embodiments of the present invention;

[0051] FIG. 19 illustrates an integrated unit in accordance with the present invention that includes a measuring device and other implements;

[0052] FIG. 20 illustrates an embodiment of the present invention, which utilizes a plurality of rings of light receivers that may be utilized to take measurements with the probe held substantially stationary with respect to the object being measured;

[0053] FIGS. 21 and 22 illustrate an embodiment of the present invention, which utilizes a mechanical movement and also may be utilized to take measurements with the probe held substantially stationary with respect to the object being measured;

[0054] FIGS. 23A to 23C illustrate embodiments of the present invention in which coherent light conduits may serve as removable probe tips;

[0055] FIGS. 24, 25 and 26 illustrate further embodiments of the present invention utilizing intraoral reflectometers, intraoral cameras and/or color calibration charts in accordance with the present invention; and

[0056] FIG. 27 illustrates an embodiment of the present invention in which an interoral camera and/or other instruments in accordance with the present invention may be adapted for use with a dental chair.

DETAILED DESCRIPTION OF THE PREFERRED EMBODIMENTS

[0057] The present invention will be described in greater detail with reference to certain preferred embodiments. At various places herein, reference is made to an "object," for example. It should be understood that an exemplary use of the present invention is in the field of dentistry, and thus the object typically should be understood to include teeth, dentures, dental-type cements or the like, although for discussion purposes in certain instances reference is only made to the "object." As described elsewhere herein, various refinements and substitutions of the various embodiments are possible based on the principles and teachings herein.

[0058] With reference to FIG. 1, an exemplary preferred embodiment of a color/optical characteristic measuring system and method in accordance with the present invention will be described. It should be noted that, at various places herein, such a color measuring system is sometimes referred to as an intraoral reflectometer, etc.

[0059] Probe tip 1 encloses a plurality of fiber optics, each of which may constitute one or more fiber optic fibers. In a preferred embodiment, the fiber optics contained within probe tip 1 includes a single light source fiber optic and three light receiver fiber optics. The use of such fiber optics to measure the color or other optical characteristics of an object will be described later herein. Probe tip 1 is attached to probe body 2, on which is fixed switch 17. Switch 17 communicates with microprocessor 10 through wire 18 and provides, for example, a mechanism by which an operator may activate the device in order to make a color/optical measurement. Fiber optics within probe tip 1 terminate at the forward end thereof (i.e., the end away from probe body 2). The forward end of probe tip 1 is directed towards the surface of the object to be measured as described more fully below. The fiber optics

within probe tip 1 optically extend through probe body 2 and through fiber optic cable 3 to light sensors 8, which are coupled to microprocessor 10.

[0060] It should be noted that microprocessor 10 includes conventional associated components, such as memory (programmable memory, such as PROM, EPROM or EEPROM; working memory such as DRAMs or SRAMs; and/or other types of memory such as non-volatile memory, such as FLASH), peripheral circuits, clocks and power supplies, although for clarity such components are not explicitly shown. Other types of computing devices (such as other microprocessor systems, programmable logic arrays or the like) are used in other embodiments of the present invention.

[0061] In the embodiment of FIG. 1, the fiber optics from fiber optic cable 3 end at splicing connector 4. From splicing connector 4, each of the three receiver fiber optics used in this embodiment is spliced into at least five smaller fiber optics (generally denoted as fibers 7), which in this embodiment are fibers of equal diameter, but which in other embodiments may be of unequal diameter (such as a larger or smaller "height/angle" or perimeter fiber, as more fully described herein). One of the fibers of each group of five fibers passes to light sensors 8 through a neutral density filter (as more fully described with reference to FIG. 3), and collectively such neutrally filtered fibers are utilized for purposes of height/angle determination (and also may be utilized to measure surface characteristics, as more fully described herein). Four of the remaining fibers of each group of fibers passes to light sensors 8 through color filters and are used to make the color/optical measurement. In still other embodiments, splicing connector 4 is not used, and fiber bundles of, for example, five or more fibers each extend from light sensors 8 to the forward end of probe tip 1. In certain embodiments, unused fibers or other materials may be included as part of a bundle of fibers for purposes of, for example, easing the manufacturing process for the fiber bundle. What should be noted is that, for purposes of the present invention, a plurality of light receiver fiber optics or elements (such as fibers 7) are presented to light sensors 8, with the light from the light receiver fiber optics/elements representing light reflected from object 20. While the various embodiments described herein present tradeoffs and benefits that may not have been apparent prior to the present invention (and thus may be independently novel), what is important for the present discussion is that light from fiber optics/elements at the forward end of probe tip 1 is presented to sensors 8 for color/optical measurements and angle/height determination, etc.

[0062] Light source 11 in the preferred embodiment is a halogen light source (of, for example, 5-100 watts, with the particular wattage chosen for the particular application), which may be under the control of microprocessor 10. The light from light source 11 reflects from cold mirror 6 and into source fiber optic 5. Source fiber optic 5 passes through to the forward end of probe tip 1 and provides the light stimulus used for purposes of making the measurements described herein. Cold mirror 6 reflects visible light and passes infra-red light, and is used to reduce the amount of infra-red light produced by light source 11 before the light is introduced into source fiber optic 5. Such infra-red light reduction of the light from a halogen source such as light source 11 can help prevent saturation of the receiving light sensors, which can reduce overall system sensitivity. Fiber 15 receives light directly from light source 11 and passes through to light sensors 8 (which may be through a neutral density filter). Microproces-

sor 10 monitors the light output of light source 11 through fiber 15, and thus may monitor and, if necessary compensate for, drift of the output of light source 11. In certain embodiments, microprocessor 10 also may sound an alarm (such as through speaker 16) or otherwise provide some indication if abnormal or other undesired performance of light source 11 is detected.

[0063] The data output from light sensors 8 pass to microprocessor 10. Microprocessor 10 processes the data from light sensors 8 to produce a measurement of color and/or other characteristics. Microprocessor 10 also is coupled to key pad switches 12, which serve as an input device. Through key pad switches 12, the operator may input control information or commands, or information relating to the object being measured or the like. In general, key pad switches 12, or other suitable data input devices (such as push button, toggle, membrane or other switches or the like), serve as a mechanism to input desired information to microprocessor 10.

[0064] Microprocessor 10 also communicates with UART 13, which enables microprocessor 10 to be coupled to an external device such as computer 13A. In such embodiments, data provided by microprocessor 10 may be processed as desired for the particular application, such as for averaging, format conversion or for various display or print options, etc. In the preferred embodiment, UART 13 is configured so as to provide what is known as a RS232 interface, such as is commonly found in personal computers.

[0065] Microprocessor 10 also communicates with LCD 14 for purposes of displaying status, control or other information as desired for the particular application. For example, color bars, charts or other graphic representations of the color or other collected data and/or the measured object or tooth may be displayed. In other embodiments, other display devices are used, such as CRTs, matrix-type LEDs, lights or other mechanisms for producing a visible indicia of system status or the like. Upon system initialization, for example, LCD 14 may provide an indication that the system is stable, ready and available for taking color measurements.

[0066] Also coupled to microprocessor 10 is speaker 16. Speaker 16, in a preferred embodiment as discussed more fully below, serves to provide audio feedback to the operator, which may serve to guide the operator in the use of the device. Speaker 16 also may serve to provide status or other information alerting the operator of the condition of the system, including an audio tone, beeps or other audible indication (i.e., voice) that the system is initialized and available for taking measurements. Speaker 16 also may present audio information indicative of the measured data, shade guide or reference values corresponding to the measured data, or an indication of the status of the color/optical measurements.

[0067] Microprocessor 10 also receives an input from temperature sensor 9. Given that many types of filters (and perhaps light sources or other components) may operate reliably only in a given temperature range, temperature sensor 9 serves to provide temperature information to microprocessor 10. In particular, color filters, such as may be included in light sensors 8, may be sensitive to temperature, and may operate reliably only over a certain temperature range. In certain embodiments, if the temperature is within a usable range, microprocessor 10 may compensate for temperature variations of the color filters. In such embodiments, the color filters are characterized as to filtering characteristics as a function of temperature, either by data provided by the filter manufacturer, or through measurement as a function of temperature.

Such filter temperature compensation data may be stored in the form of a look-up table in memory, or may be stored as a set of polynomial coefficients from which the temperature characteristics of the filters may be computed by microprocessor 10.

[0068] In general, under control of microprocessor 10, which may be in response to operator activation (through, for example, key pad switches 12 or switch 17), light is directed from light source 11, and reflected from cold mirror 6 through source fiber optic 5 (and through fiber optic cable 3, probe body 2 and probe tip 1) or through some other suitable light source element and is directed onto object 20. Light reflected from object 20 passes through the receiver fiber optics/elements in probe tip 1 to light sensors 8 (through probe body 2, fiber optic cable 3 and fibers 7). Based on the information produced by light sensors 8, microprocessor 10 produces a color/optical measurement result or other information to the operator. Color measurement or other data produced by microprocessor 10 may be displayed on display 14, passed through UART 13 to computer 13A, or used to generate audio information that is presented to speaker 16. Other operational aspects of the preferred embodiment illustrated in FIG. 1 will be explained hereinafter.

[0069] With reference to FIG. 2, a preferred embodiment of a fiber optic arrangement presented at the forward end of probe tip 1 will now be described. As illustrated in FIG. 2, a preferred embodiment of the present invention utilizes a single central light source fiber optic, denoted as light source fiber optic S, and a plurality of perimeter light receiver fiber optics, denoted as light receivers R1, R2 and R3. As is illustrated, a preferred embodiment of the present invention utilizes three perimeter fiber optics, although in other embodiments two, four or some other number of receiver fiber optics are utilized. As more fully described herein, the perimeter light receiver fiber optics serve not only to provide reflected light for purposes of making the color/optical measurement, but such perimeter fibers also serve to provide information regarding the angle and height of probe tip 1 with respect to the surface of the object that is being measured, and also may provide information regarding the surface characteristics of the object that is being measured.

[0070] In the illustrated preferred embodiment, receiver fiber optics R1 to R3 are positioned symmetrically around source fiber optic S, with a spacing of about 120 degrees from each other. It should be noted that spacing t is provided between receiver fiber optics R1 to R3 and source fiber optic S. While the precise angular placement of the receiver fiber optics around the perimeter of the fiber bundle in general is not critical, it has been determined that three receiver fiber optics positioned 120 degrees apart generally may give acceptable results. As discussed above, in certain embodiments light receiver fiber optics R1 to R3 each constitute a single fiber, which is divided at splicing connector 4 (refer again to FIG. 1), or, in alternate embodiments, light receiver fiber optics R1 to R3 each constitute a bundle of fibers, numbering, for example, at least five fibers per bundle. It has been determined that, with available fibers of uniform size, a bundle of, for example, seven fibers may be readily produced (although as will be apparent to one of skill in the art, the precise number of fibers may be determined in view of the desired number of receiver fiber optics, manufacturing considerations, etc.). The use of light receiver fiber optics R1 to R3 to produce color/optical measurements in accordance with the present invention is further described elsewhere

herein, although it may be noted here that receiver fiber optics R1 to R3 may serve to detect whether, for example, the angle of probe tip 1 with respect to the surface of the object being measured is at 90 degrees, or if the surface of the object being measured contains surface texture and/or spectral irregularities. In the case where probe tip 1 is perpendicular to the surface of the object being measured and the surface of the object being measured is a diffuse reflector (i.e., a matte-type reflector, as compared to a spectral or shiny-type reflector which may have "hot spots"), then the light intensity input into the perimeter fibers should be approximately equal. It also should be noted that spacing t serves to adjust the optimal height at which color/optical measurements should be made (as more fully described below).

[0071] In one particular aspect of the present invention, area between the fiber optics on probe tip 1 may be wholly or partially filled with a non-reflective material and/or surface (which may be a black mat, contoured or other non-reflective surface). Having such exposed area of probe tip 1 non-reflective helps to reduce undesired reflections, thereby helping to increase the accuracy and reliability of the present invention.

[0072] With reference to FIG. 3, a partial arrangement of light receiver fiber optics and sensors used in a preferred embodiment of the present invention will now be described. Fibers 7 represent light receiving fiber optics, which transmit light reflected from the object being measured to light sensors 8. In a preferred embodiment, sixteen sensors (two sets of eight) are utilized, although for ease of discussion only 8 are illustrated in FIG. 3 (in this preferred embodiment, the circuitry of FIG. 3 is duplicated, for example, in order to result in sixteen sensors). In other embodiments, other numbers of sensors are utilized in accordance with the present invention.

[0073] Light from fibers 7 is presented to sensors 8, which in a preferred embodiment pass through filters 22 to sensing elements 24. In this preferred embodiment, sensing elements 24 include light-to-frequency converters, manufactured by Texas Instruments and sold under the part number TSL230. Such converters constitute, in general, photo diode arrays that integrate the light received from fibers 7 and output an AC signal with a frequency proportional to the intensity (not frequency) of the incident light. Without being bound by theory, the basic principle of such devices is that, as the intensity increases, the integrator output voltage rises more quickly, and the shorter the integrator rise time, the greater the output frequency. The outputs of the TSL230 sensors are TTL or CMOS compatible digital signals, which may be coupled to various digital logic devices.

[0074] The outputs of sensing elements 24 are, in this embodiment, asynchronous signals of frequencies depending upon the light intensity presented to the particular sensing elements, which are presented to processor 26. In a preferred embodiment, processor 26 is a Microchip PIC16C55 or PIC16C57 microprocessor, which as described more fully herein implements an algorithm to measure the frequencies of the signals output by sensing elements 24. In other embodiments, a more integrated microprocessor/microcontroller, such as Hitachi's SH RISC microcontrollers, is utilized to provide further system integration or the like.

[0075] As previously described, processor 26 measures the frequencies of the signals output from sensing elements 24. In a preferred embodiment, processor 26 implements a software timing loop, and at periodic intervals processor 26 reads the states of the outputs of sensing elements 24. An internal counter is incremented each pass through the software timing

loop. The accuracy of the timing loop generally is determined by the crystal oscillator time base (not shown in FIG. 3) coupled to processor 26 (such oscillators typically are quite stable). After reading the outputs of sensing elements 24, processor 26 performs an exclusive OR (“XOR”) operation with the last data read (in a preferred embodiment such data is read in byte length). If any bit has changed, the XOR operation will produce a 1, and, if no bits have changed, the XOR operation will produce a 0. If the result is non-zero, the input byte is saved along with the value of the internal counter (that is incremented each pass through the software timing loop). If the result is zero, the systems waits (e.g., executes no operation instructions) the same amount of time as if the data had to be saved, and the looping operation continues. The process continues until all eight inputs have changed at least twice, which enables measurement of a full ½ period of each input. Upon conclusion of the looping process, processor 26 analyzes the stored input bytes and internal counter states. There should be 2 to 16 saved inputs (for the 8 total sensors of FIG. 3) and counter states (if two or more inputs change at the same time, they are saved simultaneously). As will be understood by one of skill in the art, the stored values of the internal counter contains information determinative of the period of the signals received from sensing elements 24. By proper subtraction of internal counter values at times when an input bit has changed, the period may be calculated. Such periods calculated for each of the outputs of sensing elements is provided by processor 26 to microprocessor 10 (see, e.g., FIG. 1). From such calculated periods, a measure of the received light intensities may be calculated.

[0076] It should be noted that the sensing circuitry and methodology illustrated in FIG. 3 have been determined to provide a practical and expedient manner in which to measure the light intensities received by sensing elements 24. In other embodiments, other circuits and methodologies are employed (other exemplary sensing schemes are described elsewhere herein).

[0077] As discussed above with reference to FIG. 1, one of fibers 7 measures light source 11, which may be through a neutral density filter, which serves to reduce the intensity of the received light in order maintain the intensity roughly in the range of the other received light intensities. Three of fibers 7 also are from perimeter receiver fiber optics R1 to R3 (see, e.g., FIG. 2) and also may pass through neutral density filters. Such receiving fibers 7 serve to provide data from which angle/height information and/or surface characteristics may be determined.

[0078] The remaining twelve fibers (of the preferred embodiment’s total of 16 fibers) of fibers 7 pass through color filters and are used to produce the color measurement. In a preferred embodiment, the color filters are Kodak Sharp Cutting Wratten Gelatin Filters, which pass light with wavelengths greater than the cut-off value of the filter (i.e., redish values), and absorb light with wavelengths less than the cut-off value of the filter (i.e., bluish values). “Sharp Cutting” filters are available in a wide variety of cut-off frequencies/wavelengths, and the cut-off values generally may be selected by proper selection of the desired cut-off filter. In a preferred embodiment, the filter cut-off values are chosen to cover the entire visible spectrum and, in general, to have band spacings of approximately the visible band range (or other desired range) divided by the number of receivers/filters. As an example, 700 nanometers minus 400 nanometers, divided by

11 bands (produced by twelve color receivers/sensors), is roughly 30 nanometer band spacing.

[0079] With an array of cut-off filters as described above, and without being bound by theory or the specific embodiments described herein, the received optical spectrum may be measured/calculated by subtracting the light intensities of “adjacent” color receivers. For example, band 1 (400 nm to 430 nm)=(intensity of receiver 12) minus (intensity of receiver 11), and so on for the remaining bands. Such an array of cut-off filters, and the intensity values that may result from filtering with such an array, are more fully described in connection with FIGS. 13A to 14B.

[0080] It should be noted here that in alternate embodiments other color filter arrangements are utilized. For example, “notch” or bandpass filters may be utilized, such as may be developed using Schott glass-type filters (whether constructed from separate longpass/shortpass filters or otherwise).

[0081] In a preferred embodiment of the present invention, the specific characteristics of the light source, filters, sensors and fiber optics, etc., are normalized/calibrated by directing the probe towards, and measuring, a known color standard. Such normalization/calibration may be performed by placing the probe in a suitable fixture, with the probe directed from a predetermined position (i.e., height and angle) from the known color standard. Such measured normalization/calibration data may be stored, for example, in a look-up table, and used by microprocessor 10 to normalize or correct measured color or other data. Such procedures may be conducted at start-up, at regular periodic intervals, or by operator command, etc.

[0082] What should be noted from the above description is that the receiving and sensing fiber optics and circuitry illustrated in FIG. 3 provide a practical and expedient way to determine the color by measuring the intensity of the light reflected from the surface of the object being measured.

[0083] It also should be noted that such a system measures the spectral band of the reflected light from the object, and once measured such spectral data may be utilized in a variety of ways. For example, such spectral data may be displayed directly as intensity-wavelength band values. In addition, tristimulus type values may be readily computed (through, for example, conventional matrix math), as may any other desired color values. In one particular embodiment useful in dental applications (such as for dental prostheses), the color data is output in the form of a closest match or matches of dental shade guide value(s). In a preferred embodiment, various existing shade guides (such as the shade guides produced by Vita Zahnfabrik) are characterized and stored in a look-up table, or in the graphics art industry Pantone color references, and the color measurement data are used to select the closest shade guide value or values, which may be accompanied by a confidence level or other suitable factor indicating the degree of closeness of the match or matches, including, for example, what are known as ΔE values or ranges of ΔE values, or criteria based on standard deviations, such as standard deviation minimization. In still other embodiments, the color measurement data are used (such as with look-up tables) to select materials for the composition of paint or ceramics such as for prosthetic teeth. There are many other uses of such spectral data measured in accordance with the present invention.

[0084] It is known that certain objects such as human teeth may fluoresce, and such optical characteristics also may be measured in accordance with the present invention. A light

source with an ultraviolet component may be used to produce more accurate color/optical data with respect to such objects. In certain embodiments, a tungsten/halogen source (such as used in a preferred embodiment) may be combined with a UV light source (such as a mercury vapor, xenon or other fluorescent light source, etc.) to produce a light output capable of causing the object to fluoresce. Alternately, a separate UV light source, combined with a visible-light-blocking filter, may be used to illuminate the object. Such a UV light source may be combined with light from a red LED (for example) in order to provide a visual indication of when the UV light is on and also to serve as an aid for the directional positioning of the probe operating with such a light source. A second measurement may be taken using the UV light source in a manner analogous to that described earlier, with the band of the red LED or other supplemental light source being ignored. The second measurement may thus be used to produce an indication of the fluorescence of the tooth or other object being measured. With such a UV light source, a silica fiber optic (or other suitable material) typically would be required to transmit the light to the object (standard fiber optic materials such as glass and plastic in general do not propagate UV light in a desired manner, etc.).

[0085] As described earlier, in certain preferred embodiments the present invention utilizes a plurality of perimeter receiver fiber optics spaced apart from and around a central source fiber optic to measure color and determine information regarding the height and angle of the probe with respect to the surface of the object being measured, which may include other surface characteristic information, etc. Without being bound by theory, certain principles underlying this aspect of the present invention will now be described with reference to FIGS. 4A to 4C.

[0086] FIG. 4A illustrates a typical step index fiber optic consisting of a core and a cladding. For this discussion, it is assumed that the core has an index of refraction of n_0 and the cladding has an index of refraction of n_1 . Although the following discussion is directed to "step index" fibers, it will be appreciated by those of skill in the art that such discussion generally is applicable for gradient index fibers as well.

[0087] In order to propagate light without loss, the light must be incident within the core of the fiber optic at an angle greater than the critical angle, which may be represented as $\text{Sin}^{-1}\{n_1/n_0\}$, where n_0 is the index of refraction of the core and n_1 is the index of refraction of the cladding. Thus, all light must enter the fiber at an acceptance angle equal to or less than ϕ , with $\phi = 2 \times \text{Sin}^{-1}\{\sqrt{(n_0^2 - n_1^2)}\}$, or it will not be propagated in a desired manner.

[0088] For light entering a fiber optic, it must enter within the acceptance angle ϕ . Similarly, when the light exits a fiber optic, it will exit the fiber optic within a cone of angle ϕ as illustrated in FIG. 4A. The value $\sqrt{(n_0^2 - n_1^2)}$ is referred to as the aperture of the fiber optic. For example, a typical fiber optic may have an aperture of 0.5, and an acceptance angle of 60° .

[0089] Consider using a fiber optic as a light source. One end is illuminated by a light source (such as light source 11 of FIG. 1), and the other is held near a surface. The fiber optic will emit a cone of light as illustrated in FIG. 4A. If the fiber optic is held perpendicular to a surface it will create a circular light pattern on the surface. As the fiber optic is raised, the radius r of the circle will increase. As the fiber optic is lowered, the radius of the light pattern will decrease. Thus, the intensity of the light (light energy per unit area) in the illumi-

nated circular area will increase as the fiber optic is lowered and will decrease as the fiber optic is raised.

[0090] The same principle generally is true for a fiber optic being utilized as a receiver. Consider mounting a light sensor on one end of a fiber optic and holding the other end near an illuminated surface. The fiber optic can only propagate light without loss when the light entering the fiber optic is incident on the end of the fiber optic near the surface if the light enters the fiber optic within its acceptance angle ϕ . A fiber optic utilized as a light receiver near a surface will only accept and propagate light from the circular area of radius r on the surface. As the fiber optic is raised from the surface, the area increases. As the fiber optic is lowered to the surface, the area decreases.

[0091] Consider two fiber optics parallel to each other as illustrated in FIG. 4B. For simplicity of discussion, the two fiber optics illustrated are identical in size and aperture. The following discussion, however, generally would be applicable for fiber optics that differ in size and aperture. One fiber optic is a source fiber optic, the other fiber optic is a receiver fiber optic. As the two fiber optics are held perpendicular to a surface, the source fiber optic emits a cone of light that illuminates a circular area of radius r . The receiver fiber optic can only accept light that is within its acceptance angle ϕ , or only light that is received within a cone of angle ϕ . If the only light available is that emitted by the source fiber optic, then the only light that can be accepted by the receiver fiber optic is the light that strikes the surface at the intersection of the two circles as illustrated in FIG. 4C. As the two fiber optics are lifted from the surface, the proportion of the intersection of the two circular areas relative to the circular area of the source fiber optic increases. As they near the surface, the proportion of the intersection of the two circular areas to the circular area of the source fiber optic decreases. If the fiber optics are held too close to the surface, the circular areas will no longer intersect and no light emitted from the source fiber optic will be received by the receiver fiber optic.

[0092] As discussed earlier, the intensity of the light in the circular area illuminated by the source fiber increases as the fiber is lowered to the surface. The intersection of the two cones, however, decreases as the fiber optic pair is lowered. Thus, as the fiber optic pair is lowered to a surface, the total intensity of light received by the receiver fiber optic increases to a maximal value, and then decreases sharply as the fiber optic pair is lowered still further to the surface. Eventually, the intensity will decrease essentially to zero (assuming the object being measured is not translucent, as described more fully herein), and will remain essentially zero until the fiber optic pair is in contact with the surface. Thus, as a source-receiver pair of fiber optics as described above are positioned near a surface and as their height is varied, the intensity of light received by the receiver fiber optic reaches a maximal value at a peaking or "critical height" h_c .

[0093] Again without being bound by theory, an interesting property of the critical height h_c has been observed. The critical height h_c is a function primarily of the geometry of fixed parameters, such as fiber apertures, fiber diameters and fiber spacing. Since the receiver fiber optic in the illustrated arrangement is only detecting a maximum value and not attempting to quantify the value, its maximum in general is independent of the surface characteristics. It is only necessary that the surface reflect sufficient light from the intersecting area of the source and receiver fiber optics to be within the detection range of the receiver fiber optic light sensor. Thus,

in general red or green or blue or any color surface will all exhibit a maximum at the same critical height h_c . Similarly, smooth reflecting surfaces and rough surfaces also will have varying intensity values at the maximal value, but generally speaking all such surfaces will exhibit a maximum at the same critical height h_c . The actual value of the light intensity will be a function of the color of the surface and of the surface characteristics, but the height where the maximum intensity value occurs in general will not. This is particularly true with respect to similar types or categories of materials, such as teeth, industrial objects, etc.

[0094] Although the above discussion has focused on two fiber optics perpendicular to a surface, similar analysis is applicable for fiber optic pairs at other angles. When a fiber optic is not perpendicular to a surface, it generally illuminates an elliptical area. Similarly, the acceptance area of a receiver fiber optic generally becomes elliptical. As the fiber optic pair is moved closer to the surface, the receiver fiber optic also will detect a maximal value at a critical height independent of the surface color or characteristics. The maximal intensity value measured when the fiber optic pair is not perpendicular to the surface, however, will be less than the maximal intensity value measured when the fiber optic pair is perpendicular to the surface.

[0095] Referring now to FIGS. 5A and 5B, the intensity of light received as a fiber optic source-receiver pair is moved to and from a surface will now be described. FIG. 5A illustrates the intensity of the received light as a function of time. Corresponding FIG. 5B illustrates the height of the fiber optic pair from the surface of the object being measured. FIGS. 5A and 5B illustrate (for ease of discussion) a relatively uniform rate of motion of the fiber optic pair to and from the surface of the object being measured (although similar illustrations/analysis would be applicable for non-uniform rates as well).

[0096] FIG. 5A illustrates the intensity of received light as the fiber optic pair is moved to and then from a surface. While FIG. 5A illustrates the intensity relationship for a single receiver fiber optic, similar intensity relationships would be expected to be observed for other receiver fiber optics, such as, for example, the multiple receiver fiber optics of FIGS. 1 and 2. In general with the preferred embodiment described above, all fifteen fiber optic receivers (of fibers 7) will exhibit curves similar to that illustrated in FIG. 5A.

[0097] FIG. 5A illustrates five regions. In region 1, the probe is moved towards the surface of the object being measured, which causes the received light intensity to increase. In region 2, the probe is moved past the critical height, and the received light intensity peaks and then falls off sharply. In region 3, the probe essentially is in contact with the surface of the object being measured. As illustrated, the received intensity in region 3 will vary depending upon the translucence of the object being measured. If the object is opaque, the received light intensity will be very low, or almost zero (perhaps out of range of the sensing circuitry). If the object is translucent, however, the light intensity will be quite high, but in general should be less than the peak value. In region 4, the probe is lifted and the light intensity rises sharply to a maximum value. In region 5, the probe is lifted further away from the object, and the light intensity decreases again.

[0098] As illustrated, two peak intensity values (discussed as P1 and P2 below) should be detected as the fiber optic pair moves to and from the object at the critical height h_c . If peaks P1 and P2 produced by a receiver fiber optic are the same value, this generally is an indication that the probe has been

moved to and from the surface of the object to be measured in a consistent manner. If peaks P1 and P2 are of different values, then these may be an indication that the probe was not moved to and from the surface of the object in a desired manner, or that the surface is curved or textured, as described more fully herein. In such a case, the data may be considered suspect and rejected. In addition, peaks P1 and P2 for each of the perimeter fiber optics (see, e.g., FIG. 2) should occur at the same critical height (assuming the geometric attributes of the perimeter fiber optics, such as aperture, diameter and spacing from the source fiber optic, etc.). Thus, the perimeter fiber optics of a probe moved in a consistent, perpendicular manner to and from the surface of the object being measured should have peaks P1 and P2 that occur at the same critical height. Monitoring receiver fibers from the perimeter receiver fiber optics and looking for simultaneous (or near simultaneous, e.g., within a predetermined range) peaks P1 and P2 provides a mechanism for determining if the probe is held at a desired perpendicular angle with respect to the object being measured.

[0099] In addition, the relative intensity level in region 3 serves as an indication of the level of translucency of the object being measured. Again, such principles generally are applicable to the totality of receiver fiber optics in the probe (see, e.g., fibers 7 of FIGS. 1 and 3). Based on such principles, measurement techniques in accordance with the present invention will now be described.

[0100] FIG. 6 is a flow chart illustrating a measuring technique in accordance with the present invention. Step 49 indicates the start or beginning of a color/optical measurement. During step 49, any equipment initialization, diagnostic or setup procedures may be performed. Audio or visual information or other indicia may be given to the operator to inform the operator that the system is available and ready to take a measurement. Initiation of the color/optical measurement commences by the operator moving the probe towards the object to be measured, and may be accompanied by, for example, activation of switch 17 (see FIG. 1).

[0101] In step 50, the system on a continuing basis monitors the intensity levels for the receiver fiber optics (see, e.g., fibers 7 of FIG. 1). If the intensity is rising, step 50 is repeated until a peak is detected. If a peak is detected, the process proceeds to step 52. In step 52, measured peak intensity P1, and the time at which such peak occurred, are stored in memory (such as in memory included as a part of microprocessor 10), and the process proceeds to step 54. In step 54, the system continues to monitor the intensity levels of the receiver fiber optics. If the intensity is falling, step 54 is repeated. If a "valley" or plateau is detected (i.e., the intensity is no longer falling, which generally indicates contact or near contact with the object), then the process proceeds to step 56. In step 56, the measured surface intensity (IS) is stored in memory, and the process proceeds to step 58. In step 58, the system continues to monitor the intensity levels of the receiver fibers. If the intensity is rising, step 58 is repeated until a peak is detected. If a peak is detected, the process proceeds to step 60. In step 60, measured peak intensity P2, and the time at which such peak occurred, are stored in memory, and the process proceeds to step 62. In step 62, the system continues to monitor the intensity levels of the receiver fiber optics. Once the received intensity levels begin to fall from peak P2, the system perceives that region 5 has been entered (see, e.g., FIG. 5A), and the process proceeds to step 64.

[0102] In step 64, the system, under control of microprocessor 10, may analyze the collected data taken by the sensing circuitry for the various receiver fiber optics. In step 64, peaks P1 and P2 of one or more of the various fiber optics may be compared. If any of peaks P1 and P2 for any of the various receiver fiber optics have unequal peak values, then the data may be rejected, and the entire color measuring process repeated. Again, unequal values of peaks P1 and P2 may be indicative, for example, that the probe was moved in a non-perpendicular or otherwise unstable manner (i.e., angular or lateral movement), and, for example, peak P1 may be representative of a first point on the object, while peak P2 may be representative of a second point on the object. As the data is suspect, in a preferred embodiment of the present invention, data taken in such circumstances are rejected in step 64.

[0103] If the data are not rejected in step 64, the process proceeds to step 66. In step 66, the system analyzes the data taken from the neutral-density-filtered receivers from each of the perimeter fiber optics (e.g., R1 to R3 of FIG. 2). If the peaks of the perimeter fiber optics did not occur at or about the same point in time, this may be indicative, for example, that the probe was not held perpendicular to the surface of the object being measured. As non-perpendicular alignment of the probe with the surface of the object being measured may cause suspect results, in a preferred embodiment of the present invention, data taken in such circumstances are rejected in step 66. In one preferred embodiment, detection of simultaneous or near simultaneous peaking (peaking within a predetermined range of time) serves as an acceptance criterion for the data, as perpendicular alignment generally is indicated by simultaneous or near simultaneous peaking of the perimeter fiber optics. In other embodiments, step 66 includes an analysis of peak values P1 and P2 of the perimeter fiber optics. In such embodiments, the system seeks to determine if the peak values of the perimeter fiber optics (perhaps normalized with any initial calibration data) are equal within a defined range. If the peak values of the perimeter fiber optics are within the defined range, the data may be accepted, and if not, the data may be rejected. In still other embodiments, a combination of simultaneous peaking and equal value detection are used as acceptance/rejection criteria for the data, and/or the operator may have the ability (such as through key pad switches 12) to control one or more of the acceptance criteria ranges. With such capability, the sensitivity of the system may be controllably altered by the operator depending upon the particular application and operative environment, etc.

[0104] If the data are not rejected in step 66, the process proceeds to step 68. In step 68, the color data may be processed in a desired manner to produce output color/optical measurement data. For example, such data may be normalized in some manner, or adjusted based on temperature compensation or other data detected by the system. The data also may be converted to different display or other formats, depending on the intended use of the data. In addition, the data indicative of the translucence of the object also may be quantified and/or displayed in step 68. After step 68, the process may proceed to starting step 49, or the process may be terminated, etc.

[0105] In accordance with the process illustrated in FIG. 6, three light intensity values (P1, P2 and IS) are stored per receiver fiber optic to make color and translucency, etc., measurements. If stored peak values P1 and P2 are not equal (for some or all of the receivers), this is an indication that the probe

was not held steady over one area, and the data may be rejected (in other embodiments, the data may not be rejected, although the resulting data may be used to produce an average of the measured data). In addition, peak values P1 and P2 for the three neutral density perimeter fiber optics should be equal or approximately equal; if this is not the case, then this is an indication that the probe was not held perpendicular or a curved surface is being measured. In other embodiments, the system attempts to compensate for curved surfaces and/or non-perpendicular angles. In any event, if the system cannot make a color/optical measurement, or if the data is rejected because peak values P1 and P2 are unequal to an unacceptable degree, then the operator is notified so that another measurement or other action may be taken (such as adjust the sensitivity).

[0106] With a system constructed and operating as described above, color/optical measurements may be taken of an object, with accepted data having height and angular dependencies removed. Data not taken at the critical height, or data not taken with the probe perpendicular to the surface of the object being measured, etc., are rejected in a preferred embodiment of the present invention. In other embodiments, data received from the perimeter fiber optics may be used to calculate the angle of the probe with respect to the surface of the object being measured, and in such embodiments non-perpendicular or curved surface data may be compensated instead of rejected. It also should be noted that peak values P1 and P2 for the neutral density perimeter fiber optics provide a measure of the luminance (gray value) of the surface of the object being measured, and also may serve to quantify the color value.

[0107] The translucency of the object being measured may be quantified as a ratio or percentage, such as, for example, $(IS/P1) \times 100\%$. In other embodiments, other methods of quantifying translucency data provided in accordance with the present invention are utilized, such as some other arithmetic function utilizing IS and P1 or P2, etc.

[0108] In another particular aspect of the present invention, data generated in accordance with the present invention may be used to implement an automated material mixing/generation machine. Certain objects/materials, such as dental prostheses, are made from porcelain or other powders/materials that may be combined in the correct ratios to form the desired color of the object/prosthesis. Certain powders often contain pigments that generally obey Beer's law and/or act in accordance with Kubelka-Munk equations and/or Saunderson equations (if needed) when mixed in a recipe. Color and other data taken from a measurement in accordance with the present invention may be used to determine or predict desired quantities of pigment or other materials for the recipe. Porcelain powders and other materials are available in different colors, opacities, etc. Certain objects, such as dental prostheses, may be layered to simulate the degree of translucency of the desired object (such as to simulate a human tooth). Data generated in accordance with the present invention also may be used to determine the thickness and position of the porcelain or other material layers to more closely produce the desired color, translucency, surface characteristics, etc. In addition, based on fluorescence data for the desired object, the material recipe may be adjusted to include a desired quantity of fluorescing-type material. In yet other embodiments, surface characteristics (such as texture) information (as more fully described herein) may be used to add a textur-

ing material to the recipe, all of which may be carried out in accordance with the present invention.

[0109] For more information regarding such pigment-material recipe type technology, reference may be made to: "The Measurement of Appearance," Second Edition, edited by Hunter and Harold, copyright 1987; "Principles of Color Technology," by Billmeyer and Saltzman, copyright 1981; and "Pigment Handbook," edited by Lewis, copyright 1988. All of the foregoing are believed to have been published by John Wiley & Sons, Inc., New York, N.Y., and all of which are hereby incorporated by reference.

[0110] In certain operative environments, such as dental applications, contamination of the probe is of concern. In certain embodiments of the present invention, implements to reduce such contamination are provided.

[0111] FIGS. 7A and 7B illustrate a protective cap that may be used to fit over the end of probe tip **1**. Such a protective cap consists of body **80**, the end of which is covered by optical window **82**, which in a preferred embodiment consists of a structure having a thin sapphire window. In a preferred embodiment, body **80** consists of stainless steel. Body **80** fits over the end of probe tip **1** and may be held into place by, for example, indentations formed in body **80**, which fit with ribs **84** (which may be a spring clip or other retainer) formed on probe tip **1**. In other embodiments, other methods of affixing such a protective cap to probe tip **1** are utilized. The protective cap may be removed from probe tip **1** and sterilized in a typical autoclave, hot steam, chemiclave or other sterilizing system.

[0112] The thickness of the sapphire window should be less than the critical height of the probe in order to preserve the ability to detect peaking in accordance with the present invention, and preferably has a thickness less than the minimal height at which the source/receiver cones overlap (see FIGS. 4B and 4C). It also is believed that sapphire windows may be manufactured in a reproducible manner, and thus any light attenuation from one cap to another may be reproducible. In addition, any distortion of the color/optical measurements produced by the sapphire window may be calibrated out by microprocessor **10**.

[0113] Similarly, in other embodiments body **80** has a cap with a hole in the center (as opposed to a sapphire window), with the hole positioned over the fiber optic source/receivers. The cap with the hole serves to prevent the probe from coming into contact with the surface, thereby reducing the risk of contamination. It should be noted that, with such embodiments, the hole is positioned so that the light from/to the light source/receiver elements of the probe tip is not adversely affected by the cap.

[0114] FIGS. 8A and 8B illustrate another embodiment of a removable probe tip that may be used to reduce contamination in accordance with the present invention. As illustrated in FIG. 8A, probe tip **88** is removable, and includes four (or a different number, depending upon the application) fiber optic connectors **90**, which are positioned within optical guard **92** coupled to connector **94**. Optical guard **92** serves to prevent "cross talk" between adjacent fiber optics. As illustrated in FIG. 8B, in this embodiment removable tip **88** is secured in probe tip housing **93** by way of spring clip **96** (other removable retaining implements are utilized in other embodiments). Probe tip housing **93** may be secured to base connector **95** by a screw or other conventional fitting. It should be noted that, with this embodiment, different size tips may be provided for different applications, and that an initial step of the process

may be to install the properly-sized (or fitted tip) for the particular application. Removable tip **88** also may be sterilized in a typical autoclave, hot steam, chemiclave or other sterilizing system, or disposed of. In addition, the entire probe tip assembly is constructed so that it may be readily disassembled for cleaning or repair. In certain embodiments the light source/receiver elements of the removable tip are constructed of glass, silica or similar materials, thereby making them particularly suitable for autoclave or similar high temperature/pressure cleaning methods, which in certain other embodiments the light source/receiver elements of the removable tip are constructed of plastic or other similar materials, which may be of lower cost, thereby making them particularly suitable for disposable-type removable tips, etc.

[0115] In still other embodiments, a plastic, paper or other type shield (which may be disposable, cleanable/reusable or the like) may be used in order to address any contamination concerns that may exist in the particular application. In such embodiments, the methodology may include positioning such a shield over the probe tip prior to taking color/optical measurements, and may include removing and disposing/cleaning the shield after taking color/optical measurements, etc.

[0116] With reference to FIG. 9, a tristimulus embodiment of the present invention will now be described. In general, the overall system depicted in FIG. 1 and discussed in detail elsewhere herein may be used with this embodiment. FIG. 9 illustrates a cross section of the probe tip fiber optics used in this embodiment.

[0117] Probe tip **100** includes central source fiber optic **106**, surrounded by (and spaced apart from) three perimeter receiver fiber optics **104** and three color receiver fiber optics **102**. Three perimeter receiver fiber optics **104** are optically coupled to neutral density filters and serve as height/angle sensors in a manner analogous to the embodiment describe above. Three color receiver fiber optics are optically coupled to suitable tristimulus filters, such as red, green and blue filters. With this embodiment, a measurement may be made of tristimulus color values of the object, and the process described with reference to FIG. 6 generally is applicable to this embodiment. In particular, perimeter fiber optics **104** may be used to detect simultaneous peaking or otherwise whether the probe is perpendicular to the object being measured. In addition, taking color measurement data at the critical height also may be used with this embodiment.

[0118] FIG. 10A illustrates an embodiment of the present invention, similar to the embodiment discussed with reference to FIG. 9. Probe tip **100** includes central source fiber optic **106**, surrounded by (and spaced apart from) three perimeter receiver fiber optics **104** and a plurality of color receiver fiber optics **102**. The number of color receiver fiber optics **102**, and the filters associated with such receiver fiber optics **102**, may be chosen based upon the particular application. As with the embodiment of FIG. 9, the process described with reference to FIG. 6 generally is applicable to this embodiment.

[0119] FIG. 10B illustrates an embodiment of the present invention in which there are a plurality of receiver fiber optics that surround central source fiber optic **240**. The receiver fiber optics are arranged in rings surrounding the central source fiber optic. FIG. 10B illustrates three rings of receiver fiber optics (consisting of fiber optics **242**, **244** and **246**, respectively), in which there are six receiver fiber optics per ring. The rings may be arranged in successive larger circles as

illustrated to cover the entire area of the end of the probe, with the distance from each receiver fiber optic within a given ring to the central fiber optic being equal (or approximately so). Central fiber optic **240** is utilized as the light source fiber optic and is connected to the light source in a manner similar to light source fiber optic **5** illustrated in FIG. **1**.

[**0120**] The plurality of receiver fiber optics are each coupled to two or more fiber optics in a manner similar to the arrangement illustrated in FIG. **1** for splicing connector **4**. One fiber optic from such a splicing connector for each receiver fiber optic passes through a neutral density filter and then to light sensor circuitry similar to the light sensor circuitry illustrated in FIG. **3**. A second fiber optic from the splicing connector per receiver fiber optic passes through a Sharp Cutting Wrattan Gelatin Filter and then to light sensor circuitry as discussed elsewhere herein. Thus, each of the receiver fiber optics in the probe tip includes both color measuring elements and neutral light measuring or "perimeter" elements.

[**0121**] FIG. **10D** illustrates the geometry of probe **260** (such as described above) illuminating an area on flat diffuse surface **272**. Probe **260** creates light pattern **262** that is reflected diffusely from surface **272** in uniform hemispherical pattern **270**. With such a reflection pattern, the reflected light that is incident upon the receiving elements in the probe will be equal (or nearly equal) for all elements if the probe is perpendicular to the surface as described above herein.

[**0122**] FIG. **10C** illustrates a probe illuminating rough surface **268** or a surface that reflects light spectrally. Spectral reflected light will exhibit hot spots or regions **266** where the reflected light intensity is considerably greater than it is on other areas **264**. The reflected light pattern will be uneven when compared to a smooth surface as illustrate in FIG. **10D**.

[**0123**] Since a probe as illustrated in FIG. **10B** has a plurality of receiver fiber optics arranged over a large surface area, the probe may be utilized to determine the surface texture of the surface as well as being able to measure the color and translucency, etc., of the surface as described earlier herein. If the light intensity received by the receiver fiber optics is equal for all fiber optics within a given ring of receiver fiber optics, then generally the surface is diffuse and smooth. If, however, the light intensity of receiver fibers in a ring varies with respect to each other, then generally the surface is rough or spectral. By comparing the light intensities measured within receiver fiber optics in a given ring and from ring to ring, the texture and other characteristics of the surface may be quantified.

[**0124**] FIG. **11** illustrates an embodiment of the present invention in which linear optical sensors and a color gradient filter are utilized instead of light sensors **8** (and filters **22**, etc.).

[**0125**] Receiver fiber optics **7**, which may be optically coupled to probe tip **1** as with the embodiment of FIG. **1**, are optically coupled to linear optical sensor **112** through color gradient filter **110**. In this embodiment, color gradient filter **110** may consist of series of narrow strips of cut-off type filters on a transparent or open substrate, which are constructed so as to positionally correspond to the sensor areas of linear optical sensor **112**. An example of a commercially available linear optical sensor **112** is Texas Instruments part number TSL213, which has 61 photo diodes in a linear array. Light receiver fiber optics **7** are arranged correspondingly in a line over linear optical sensor **112**. The number of receiver fiber optics may be chosen for the particular application, so long as enough are included to more or less evenly cover the

full length of color gradient filter **110**. With this embodiment, the light is received and output from receiver fiber optics **7**, and the light received by linear optical sensor **112** is integrated for a short period of time (determined by the light intensity, filter characteristics and desired accuracy). The output of linear array sensor **112** is digitized by ADC **114** and output to microprocessor **116** (which may the same processor as microprocessor **10** or another processor).

[**0126**] In general, with the embodiment of FIG. **11**, perimeter receiver fiber optics may be used as with the embodiment of FIG. **1**, and in general the process described with reference to FIG. **6** is applicable to this embodiment.

[**0127**] FIG. **12** illustrates an embodiment of the present invention in which a matrix optical sensor and a color filter grid are utilized instead of light sensors **8** (and filters **22**, etc.). Receiver fiber optics **7**, which may be optically coupled to probe tip **1** as with the embodiment of FIG. **1**, are optically coupled to matrix optical sensor **122** through filter grid **120**. Filter grid **120** is a filter array consisting of a number of small colored spot filters that pass narrow bands of visible light. Light from receiver fiber optics **7** pass through corresponding filter spots to corresponding points on matrix optical sensor **122**. In this embodiment, matrix optical sensor **122** may be a monochrome optical sensor array, such as CCD-type or other type of light sensor element such as may be used in a video camera. The output of matrix optical sensor **122** is digitized by ADC **124** and output to microprocessor **126** (which may the same processor as microprocessor **10** or another processor). Under control of microprocessor **126**, matrix optical sensor **126** collects data from receiver fiber optics **7** through color filter grid **120**.

[**0128**] In general, with the embodiment of FIG. **12**, perimeter receiver fiber optics may be used as with the embodiment of FIG. **1**, and in general the process described with reference to FIG. **6** also is applicable to this embodiment.

[**0129**] As will be clear from the foregoing description, with the present invention a variety of types of spectral color/optical photometers (or tristimulus-type colorimeters) may be constructed, with perimeter receiver fiber optics used to collect color/optical data essentially free from height and angular deviations. In addition, in certain embodiments, the present invention enables color/optical measurements to be taken at a critical height from the surface of the object being measured, and thus color/optical data may be taken without physical contact with the object being measured (in such embodiments, the color/optical data is taken only by passing the probe through region **1** and into region **2**, but without necessarily going into region **3** of FIGS. **5A** and **5B**). Such embodiments may be utilized if contact with the surface is undesirable in a particular application. In the embodiments described earlier, however, physical contact (or near physical contact) of the probe with the object may allow all five regions of FIGS. **5A** and **5B** to be utilized, thereby enabling measurements to be taken such that translucency information also may be obtained. Both types of embodiments generally are within the scope of the invention described herein.

[**0130**] Additional description will now be provided with respect to cut-off filters of the type described in connection with the preferred embodiment(s) of FIGS. **1** and **3** (such as filters **22** of FIG. **3**). FIG. **13A** illustrates the properties of a single Kodak Sharp Cutting Wrattan Gelatin Filter discussed in connection with FIG. **3**. Such a cut-off filter passes light below a cut-off frequency (i.e., above a cut-off wavelength). Such filters may be manufactured to have a wide range of

cut-off frequencies/wavelengths. FIG. 13B illustrates a number of such filters, twelve in a preferred embodiment, with cut-off frequencies/wavelengths chosen so that essentially the entire visible band is covered by the collection of cut-off filters.

[0131] FIGS. 14A and 14B illustrate exemplary intensity measurements using a cut-off filter arrangement such as illustrated in FIG. 13B, first in the case of a white surface being measured (FIG. 14A), and also in the case of a blue surface being measured (FIG. 14B). As illustrated in FIG. 14A, in the case of a white surface, the neutrally filtered perimeter fiber optics, which are used to detect height and angle, etc., generally will produce the highest intensity (although this depends at least in part upon the characteristics of the neutral density filters). As a result of the stepped cut-off filtering provided by filters having the characteristics illustrated in FIG. 13B, the remaining intensities will gradually decrease in value as illustrated in FIG. 14A. In the case of a blue surface, the intensities will decrease in value generally as illustrated in FIG. 14B. Regardless of the surface, however, the intensities out of the filters will always decrease in value as illustrated, with the greatest intensity value being the output of the filter having the lowest wavelength cut-off value (i.e., passes all visible light up to blue), and the lowest intensity value being the output of the filter having the highest wavelength cut-off (i.e., passes only red visible light). As will be understood from the foregoing description, any color data detected that does not fit the decreasing intensity profiles of FIGS. 14A and 14B may be detected as an abnormality, and in certain embodiments detection of such a condition results in data rejection, generation of an error message or initiation of a diagnostic routine, etc.

[0132] Reference should be made to the FIGS. 1 and 3 and the related description for a detailed discussion of how such a cut-off filter arrangement may be utilized in accordance with the present invention.

[0133] FIG. 15 is a flow chart illustrating audio tones that may be used in certain preferred embodiments of the present invention. It has been discovered that audio tones (such as tones, beeps, voice or the like such as will be described) present a particularly useful and instructive means to guide an operator in the proper use of a color measuring system of the type described herein.

[0134] The operator may initiate a color/optical measurement by activation of a switch (such as switch 17 of FIG. 1) at step 150. Thereafter, if the system is ready (set-up, initialized, calibrated, etc.), a lower-the-probe tone is emitted (such as through speaker 16 of FIG. 1) at step 152. The system attempts to detect peak intensity P1 at step 154. If a peak is detected, at step 156 a determination is made whether the measured peak P1 meets the applicable criteria (such as discussed above in connection with FIGS. 5A, 5B and 6). If the measured peak P1 is accepted, a first peak acceptance tone is generated at step 160. If the measured peak P1 is not accepted, an unsuccessful tone is generated at step 158, and the system may await the operator to initiate a further color/optical measurement. Assuming that the first peak was accepted, the system attempts to detect peak intensity P2 at step 162. If a second peak is detected, at step 164 a determination is made whether the measured peak P2 meets the applicable criteria. If the measured peak P2 is accepted the process proceeds to color calculation step 166 (in other embodiments, a second peak acceptance tone also is generated at step 166). If the measured peak P2 is not accepted, an unsuccessful tone is

generated at step 158, and the system may await the operator to initiate a further color/optical measurement. Assuming that the second peak was accepted, a color/optical calculation is made at step 166 (such as, for example, microprocessor 10 of FIG. 1 processing the data output from light sensors 8, etc.). At step 168, a determination is made whether the color calculation meets the applicable criteria. If the color calculation is accepted, a successful tone is generated at step 170. If the color calculation is not accepted, an unsuccessful tone is generated at step 158, and the system may await the operator to initiate a further color/optical measurement.

[0135] With unique audio tones presented to an operator in accordance with the particular operating state of the system, the operator's use of the system may be greatly facilitated. Such audio information also tends to increase operator satisfaction and skill level, as, for example, acceptance tones provide positive and encouraging feedback when the system is operated in a desired manner.

[0136] The color/optical measuring systems and methods in accordance with the present invention may be applied to particular advantage in the field of dentistry, as will be more fully explained hereinafter. In particular the present invention includes the use of such systems and methods to measure the color and other attributes of a tooth in order to prepare a dental prosthesis or intraoral tooth-colored fillings, or to select denture teeth or to determine a suitable cement color for porcelain/resin prostheses. The present invention also provides methods for storing and organizing measured data such as in the form of a patient database.

[0137] FIG. 16 is a flow chart illustrating a general dental application process flow for use of the color/optical measuring systems and methods in accordance with the present invention. At step 200, the color/optical measuring system may be powered-up and stabilized, with any required initialization or other setup routines performed. At step 200, an indication of the system status may be provided to the operator, such as through LCD 14 or speaker 16 of FIG. 1. Also at step 200, the probe tip may be shielded or a clean probe tip may be inserted in order to reduce the likelihood of contamination (see, e.g., FIGS. 7A to 8B and related description). In other embodiments, a plastic or other shield may also be used (which may be disposable, cleanable/reusable, etc., as previously described), so long as it is constructed and/or positioned so as to not adversely affect the measurement process.

[0138] At step 202, the patient and the tooth to be measured are prepared. Any required cleaning or other tooth preparation would be performed at step 202. Any required patient consultation about the type of prosthesis or area of a tooth to be matched would be performed at (or before) step 202. In certain embodiments, a positioning device is prepared at step 202, such as is illustrated in FIGS. 17A and 17B. In such embodiments, for example, a black or other suitably-colored material 282, which may adhere to tooth 280 (such as with a suitable adhesive), is formed to have opening 281 larger than the diameter of the measuring probe, with opening 281 centered on the area of tooth 280 to be measured. The material of positioning device 282 is formed in a manner to fit on/over tooth 280 (such as over the incisal edge of tooth 280 and/or over one or more adjacent teeth) so that it may be placed on/over tooth 280 in a repeatable manner. Such a positioning device may serve to ensure that the desired area of tooth 280 is measured, and also allows for repeat measurements of the

same area for purposes of confirmation or the like. Any other pre-measurement activities may be performed at (or before) step 202.

[0139] At step 204, the operator (typically a dentist or other dental professional) moves the probe towards the area of the tooth to be measured. This process preferably is conducted in accordance with the methodology described with reference to FIGS. 5A, 5B and 6, and preferably is accompanied by audio tones such as described with reference to FIG. 15. With the present invention, the operator may obtain color and translucency data, etc., for example, from a desired area of the tooth to be measured. During step 204, an accepted color/optical measurement is made, or some indication is given to the operator that the measurement step needs to be repeated or some other action taken. After an accepted color/optical measurement is made at step 204, for example, the dentist may operate on the desired tooth or teeth or take other action. Before or after such action, additional measurements may be taken as needed (see, e.g., FIG. 18 and related description).

[0140] Upon successful completion of one or more measurements taken at step 204, the process proceeds to step 206. At step 206, any data conversion or processing of data collected at step 204 may be performed. For example, in the embodiment of FIG. 1, detailed color spectrum and translucency information may be generated. In a particular dental application, however, it may be that a dental lab, for example, requires that the color be presented in Munsell format (i.e., chroma, hue and value), RGB values, XYZ coordinates, CIELAB values, Hunter values, or some other color data format. With the spectral/color information produced by the present invention, data may be converted to such formats through conventional matrix math, for example. Such math may be performed by microprocessor 10 or computer 13A of FIG. 1, or in some other manner. It also should be noted that, in certain embodiments, the data produced at step 204 in accordance with the present invention may be used directly without data conversion. In such embodiments, step 206 may be omitted. In other embodiments, step 206 consists of data formatting, such as preparing the data for reproduction in hard copy, pictorial or other form, or for transmission as facsimile or modem data. Finally, in certain embodiments a translucency factor is computed in a format suitable for the particular application. In yet other embodiments, a surface texture or detail factor is computed in a format suitable for the particular application.

[0141] At step 208, a matching is optionally attempted between the data produced at steps 204 and 206 (if performed) and a desired color (in other embodiments, the process may proceed from 204 directly to 210, or alternatively steps 206 and 208 may be combined). For example, a number of "shade guides" are available in the market, some of which are known in the industry as Vita shade guides, Bioform shade guides or other color matching standards, guides or references or custom shade guides. In certain preferred embodiments, a lookup table is prepared and loaded into memory (such as memory associated with microprocessor 10 or computer 13A of FIG. 1), and an attempt is made to the closest match or matches of the collected data with the known shade guides, custom shade guides or reference values. In certain embodiments, a translucency factor and/or a surface texture or detail factor also is used in an effort to select the best possible match.

[0142] In a particular aspect of certain embodiments of the present invention, at step 208 a material correlation lookup

table is accessed. Based on the color and translucency data obtained at step 204, a proposed recipe of materials, pigments or other instruction information is prepared for a prosthesis or filling, etc., of the desired color and translucency, etc. With the detailed color and other information made available in accordance with the present invention, a direct correlation with the relevant constituent materials may be made. In still other embodiments, such information is made available to an automated mixing or manufacturing machine for preparation of prosthesis or material of the desired color and translucency, etc., as more fully described elsewhere herein.

[0143] At step 210, based on the results of the preceding steps, the prosthesis, denture, intraoral tooth-colored filling material or other items are prepared. This step may be performed at a dental lab, or, in certain embodiments, at or near the dental operator. For remote preparation, relevant data produced at steps 204, 206 and/or 208 may be sent to the remote lab or facility by hardcopy, facsimile or modem or other transmission. What should be understood from the foregoing is that, based on data collected at step 204, a prosthesis may be prepared of a desirable color and/or other optical characteristic at step 210.

[0144] At step 212, the prosthesis or other material prepared at step 210 may be measured for confirmation purposes, again preferably conducted in accordance with the methodology described with reference to FIGS. 5A, 5B and 6, and preferably accompanied by audio tones such as described with reference to FIG. 15. A re-measure of the tooth in the patient's mouth, etc. also may be made at this step for confirmation purposes. If the confirmation process gives satisfactory results, the prosthesis, denture, composite filling or other material may be preliminarily installed or applied in the patient at step 214. At step 216, a re-measure of the prosthesis, denture, composite filling or other materials optionally may be made. If the results of step 216 are acceptable, then the prosthesis may be more permanently installed or applied in the patient at step 218. If the results of step 216 are not acceptable, the prosthesis may be modified and/or other of the steps repeated as necessary in the particular situation.

[0145] In another particular aspect of the present invention, for example, data processing such as illustrated in FIG. 18 may be taken in conjunction with the process of FIG. 16. At step 286, client database software is run on a computing device, such as computer 13A of FIG. 1. Such software may include data records for each patient, including fields storing the history of dental services performed on the patient, information regarding the status or condition of the patient's teeth, billing, address and other information. Such software may enter a mode by which it is in condition to accept color or other data taken in accordance with the present invention.

[0146] At step 288, for example, the dentist or other dental professional may select parameters for a particular tooth of the patient to be measured. Depending on the size and condition of the tooth (such as color gradient or the like), the dentist may sector the tooth into one or more regions, such as a grid. Thus, for example, in the case of tooth for which it is decided to take four measurements, the tooth may be sectorized into four regions. Such parameters, which may include a pictorial representation on the computer of the tooth sectorized into four regions (such as by grid lines), along with tooth identification and patient information may be entered into the computer at this time.

[0147] At step 290, one or more measurements of the tooth may be taken, such as with a system and method as described

in connection with FIGS. 1, 5A, 5B and/or 6. The number of such measurements preferably is associated with the parameters entered at step 288. Thereafter, at step 292, the data collected from the measurement(s) may be sent to the computer for subsequent processing. As an illustrative example, four color/optical measurements may be taken (for the four regions of the tooth in the above example) and sent to the computer, with the data for the four color/optical measurements (such as RGB or other values) associated with the four regions in accordance with the entered parameters. Also as an example, the displayed pictorial representation of the tooth may have overlaid thereof data indicative of the color/optical measurement(s). At step 294, such as after completion of color/optical measurements on the particular patient, the data collected during the process may be associatively stored as a part of the patient's dental records in the data base. In embodiments accompanied by use of an intraoral camera, for example (see, e.g., FIG. 19 and related description), captured images of one or more of the patient's teeth also may be associatively stored as part of the patient's dental records. In certain embodiments, a picture captured by the intraoral camera is overlaid with grid or sector lines (such as may be defined in step 288), with color or other data measured as described herein also overlaid over the captured image. In such a manner, the color or other data may be electronically and visually associated with a picture of the particular measured tooth, thereby facilitating the use of the system and the understanding of the collected data. In still other embodiments, all such captured image and color measurement records include a time and/or date, so that a record of the particular history of a particular tooth of a particular patient may be maintained. See FIGS. 24 to 26 and related description for additional embodiments utilizing an intraoral camera, etc., in accordance with the present invention.

[0148] In yet another particular aspect of the present invention, a measuring device and method (such as described elsewhere herein) may be combined with an intraoral camera and other implements. As illustrated in FIG. 19, control unit 300 contains conventional electronics and circuitry, such as power supplies, control electronics, light sources and the like. Coupled to control unit 300 is intraoral camera 301 (for viewing, and capturing images of, a patient's tooth or mouth, etc.), curing light 302 (such as for curing light-cured intraoral filling material), measuring device 304 (such as described elsewhere herein), and visible light 306 (which may be an auxiliary light for intraoral examinations and the like). With such embodiments, color, translucency, fluorescence, surface texture and/or other data collected for a particular tooth from measuring device 304 may be combined with images captured by intraoral camera 301, with the overall examination and processing of the patient facilitated by having measuring device 304, intraoral camera 301, curing light 302 and visible light 306 integrated into a single unit. Such integration serves to provide synergistic benefits in the use of the instruments, while also reducing costs and saving physical space. In another particular aspect of such embodiments, the light source for measuring device 304 and intraoral camera 301 are shared, thereby resulting in additional benefits.

[0149] Further embodiments of the present invention will now be described with reference to FIGS. 20 to 23. The previously described embodiments generally rely on movement of the probe with respect to the object/tooth being measured. While such embodiments provide great utility in many applications, in certain applications, such as robotics, indus-

trial control, automated manufacturing, etc. (such as positioning the object and/or the probe to be in proximity to each other, detecting color/optical properties of the object, and then directing the object, e.g., sorting, based on the detected color/optical properties, for further industrial processing, packaging, etc.) it may be desired to have the measurement made with the probe held or positioned substantially stationary above the surface of the object to be measured (in such embodiments, the positioned probe may not be handheld as with certain other embodiments). Such embodiments also may have applicability in the field of dentistry (in such applications, "object" generally refers to a tooth, etc.).

[0150] FIG. 20 illustrates such a further embodiment. The probe of this embodiment includes a plurality of perimeter sensors and a plurality of color sensors coupled to receivers 312-320. The color sensors and related components, etc., may be constructed to operate in a manner analogous to previously described embodiments. For example, fiber optic cables or the like may couple light from source 310 that is received by receivers 312-320 to sharp cut-off filters, with the received light measured over precisely defined wavelengths (see, e.g., FIGS. 1, 3 and 11-14 and related description). Color/optical characteristics of the object may be determined from the plurality of color sensor measurements, which may include three such sensors in the case of a tristimulus instrument, or 8, 12, 15 or more color sensors for a more full bandwidth system (the precise number may be determined by the desired color resolution, etc.).

[0151] With this embodiment, a relatively greater number of perimeter sensors are utilized (as opposed, for example, to the three perimeter sensors used in certain preferred embodiments of the present invention). As illustrated in FIG. 20, a plurality of triads of receivers 312-320 coupled to perimeter sensors are utilized, where each triad in the preferred implementation consists of three fiber optics positioned equal distance from light source 310, which in the preferred embodiment is a central light source fiber optic. The triads of perimeter receivers/sensors may be configured as concentric rings of sensors around the central light source fiber optic. In FIG. 20, ten such triad rings are illustrated, although in other embodiments a lesser or greater number of triad rings may be utilized, depending upon the desired accuracy and range of operation, as well as cost considerations and the like.

[0152] The probe illustrated in FIG. 20 may operate within a range of heights (i.e., distances from the object being measured). As with earlier embodiments, such height characteristics are determined primarily by the geometry and constituent materials of the probe, with the spacing of the minimal ring of perimeter sensors determining the minimal height, and the spacing of the maximal ring of perimeter sensors determining the maximum height, etc. It therefore is possible to construct probes of various height ranges and accuracy, etc., by varying the number of perimeter sensor rings and the range of ring distances from the central source fiber optic. It should be noted that such embodiments may be particularly suitable when measuring similar types of materials, etc.

[0153] As described earlier, the light receiver elements for the plurality of receivers/perimeter sensors may be individual elements such as Texas Instruments TSL230 light-to-frequency converters, or may be constructed with rectangular array elements or the like such as may be found in a CCD camera. Other broadband-type of light measuring elements are utilized in other embodiments. Given the large number of perimeter sensors used in such embodiments (such as 30 for

the embodiment of FIG. 16), an array such as CCD camera-type sensing elements may be desirable. It should be noted that the absolute intensity levels of light measured by the perimeter sensors is not as critical to such embodiments of the present invention; in such embodiments differences between the triads of perimeter light sensors are advantageously utilized in order to obtain optical measurements.

[0154] Optical measurements may be made with such a probe by holding/positioning the probe near the surface of the object being measured (i.e., within the range of acceptable heights of the particular probe). The light source providing light to light source 310 is turned on and the reflected light received by receivers 312-320 (coupled to the perimeter sensors) is measured. The light intensity of the rings of triad sensors is compared. Generally, if the probe is perpendicular to the surface and if the surface is flat, the light intensity of the three sensors of each triad should be approximately equal. If the probe is not perpendicular to the surface or if the surface is not flat, the light intensity of the three sensors within a triad will not be equal. It is thus possible to determine if the probe is perpendicular to the surface being measured, etc. It also is possible to compensate for non-perpendicular surfaces by mathematically adjusting the light intensity measurements of the color sensors with the variance in measurements of the triads of perimeter sensors.

[0155] Since the three sensors forming triads of sensors are at different distances (radii) from central light source 310, it is expected that the light intensities measured by light receivers 312-320 and the perimeter sensors will vary. For any given triad of sensors, as the probe is moved closer to the surface, the received light intensity will increase to a maximum and then sharply decrease as the probe is moved closer to the surface. As with previously-described embodiments, the intensity decreases rapidly as the probe is moved less than the critical height and decreases rapidly to zero or almost zero for opaque objects. The value of the critical height depends principally upon the distance of the particular receiver from light source 310. Thus, the triads of sensors will peak at different critical heights. By analyzing the variation in light values received by the triads of sensors, the height of the probe can be determined. Again, this is particularly true when measuring similar types of materials.

[0156] The system initially is calibrated against a neutral background (e.g., a gray background), and the calibration values are stored in non-volatile memory (see, e.g., processor 10 of FIG. 1). For any given color or intensity, the intensity for the receivers/perimeter sensors (independent of distance from the central source fiber optic) in general should vary equally. Hence, a white surface should produce the highest intensities for the perimeter sensors, and a black surface will produce the lowest intensities. Although the color of the surface will affect the measured light intensities of the perimeter sensors, it should affect them substantially equally. The height of the probe from the surface of the object, however, will affect the triads of sensors differently. At the minimal height range of the probe, the triad of sensors in the smallest ring (those closest to the source fiber optic) will be at or about their maximal value. The rest of the rings of triads will be measuring light at intensities lower than their maximal values. As the probe is raised/positioned from the minimal height, the intensity of the smallest ring of sensors will decrease and the intensity of the next ring of sensors will increase to a maximal value and will then decrease in intensity as the probe is raised/positioned still further. Similarly for

the third ring, fourth ring and so on. Thus, the pattern of intensities measured by the rings of triads will be height dependent. In such embodiments, characteristics of this pattern may be measured and stored in non-volatile RAM look-up tables (or the like) for the probe by calibrating it in a fixture using a neutral color surface. Again, the actual intensity of light is not as important in such embodiments, but the degree of variance from one ring of perimeter sensors to another is.

[0157] To determine a measure of the height of the probe from the surface being measured, the intensities of the perimeter sensors (coupled to receivers 312-320) is measured. The variance in light intensity from the inner ring of perimeter sensors to the next ring and so on is analyzed and compared to the values in the look-up table to determine the height of the probe. The determined height of the probe with respect to the surface thus may be utilized by the system processor to compensate for the light intensities measured by the color sensors in order to obtain reflectivity readings that are in general independent of height. As with previously described embodiments, the reflectivity measurements may then be used to determine optical characteristics of the object being measured, etc.

[0158] It should be noted that audio tones, such as previously described, may be advantageously employed when such an embodiment is used in a handheld configuration. For example, audio tones of varying pulses, frequencies and/or intensities may be employed to indicate the operational status of the instrument, when the instrument is positioned within an acceptable range for color measurements, when valid or invalid color measurements have been taken, etc. In general, audio tones as previously described may be adapted for advantageous use with such further embodiments.

[0159] FIG. 21 illustrates a further such embodiment of the present invention. The preferred implementation of this embodiment consists of a central light source 310 (which in the preferred implementation is a central light source fiber optic), surrounded by a plurality of light receivers 322 (which in the preferred implementation consists of three perimeter light receiver fiber optics). The three perimeter light receiver fiber optics, as with earlier described embodiments, may be each spliced into additional fiber optics that pass to light intensity receivers/sensors, which may be implemented with Texas Instruments TSL230 light to frequency converters as described previously. One fiber of each perimeter receiver is coupled to a sensor and measured full band width (or over substantially the same bandwidth) such as via a neutral density filter, and other of the fibers of the perimeter receivers are coupled to sensors so that the light passes through sharp cut off or notch filters to measure the light intensity over distinct frequency ranges of light (again, as with earlier described embodiments). Thus there are color light sensors and neutral "perimeter" sensors as with previously described embodiments. The color sensors are utilized to determine the color or other optical characteristics of the object, and the perimeter sensors are utilized to determine if the probe is perpendicular to the surface and/or are utilized to compensate for non-perpendicular angles within certain angular ranges.

[0160] In the embodiment of FIG. 21, the angle of the perimeter sensor fiber optics is mechanically varied with respect to the central source fiber optic. The angle of the perimeter receivers/sensors with respect to the central source fiber optic is measured and utilized as described hereinafter. An exemplary mechanical mechanism, the details of which are not critical so long as desired, control movement of the

perimeter receivers with respect to the light source is obtained, is described with reference to FIG. 22.

[0161] The probe is held within the useful range of the instrument (determined by the particular configuration and construction, etc.), and a color measurement is initiated. The angle of the perimeter receivers/sensors with respect to the central light source is varied from parallel to pointing towards the central source fiber optic. While the angle is being varied, the intensities of the light sensors for the perimeter sensors (e.g., neutral sensors) and the color sensors is measured and saved along with the angle of the sensors at the time of the light measurement. The light intensities are measured over a range of angles. As the angle is increased the light intensity will increase to a maximum value and will then decrease as the angle is further increased. The angle where the light values is a maximum is utilized to determine the height of the probe from the surface. As will be apparent to those skilled in the art based on the teachings provided herein, with suitable calibration data, simple geometry may be utilized to calculate the height based on the data measured during variation of the angle. The height measurement may then be utilized to compensate for the intensity of the color/optical measurements and/or utilized to normalize color values, etc.

[0162] FIG. 22 illustrates an exemplary embodiment of a mechanical arrangement to adjust and measure the angle of the perimeter sensors. Each perimeter receiver/sensor 322 is mounted with pivot arm 326 on probe frame 328. Pivot arm 326 engages central ring 332 in a manner to form a cam mechanism. Central ring 332 includes a groove that holds a portion of pivot arm 326 to form the cam mechanism. Central ring 332 may be moved perpendicular with respect to probe frame 328 via linear actuator 324 and threaded spindle 330. The position of central ring 332 with respect to linear actuator 324 determines the angle of perimeter receivers/sensors 322 with respect to light source 310. Such angular position data vis-a-vis the position of linear actuator 324 may be calibrated in advance and stored in non-volatile memory, and later used to produce color/optical characteristic measurement data as previously described.

[0163] A further embodiment of the present invention utilizing an alternate removable probe tip will now be described with reference to FIGS. 23A-23C. As illustrated in FIG. 23A, this embodiment utilizes removable, coherent light conduit 340 as a removable tip. Light conduit 340 is a short segment of a light conduit that preferably may be a fused bundle of small fiber optics, in which the fibers are held essentially parallel to each other, and the ends of which are highly polished. Cross-section 350 of light conduit 340 is illustrated in FIG. 23B. Light conduits similar to light conduit 340 have been utilized in what are known as borescopes, and also have been utilized in medical applications such as endoscopes. Light conduit 340 in this embodiment serves to conduct light from the light source to the surface of the object being measured, and also to receive reflected light from the surface and conduct it to light receiver fiber optics 346 in probe handle 344. Light conduit 340 is held in position with respect to fiber optics 346 by way of compression jaws 342 or other suitable fitting or coupled that reliably positions light conduit 340 so as to couple light effectively to/from fiber optics 346. Fiber optics 346 may be separated into separate fibers/light conduits 348, which may be coupled to appropriate light sensors, etc., as with previously described embodiments.

[0164] In general, the aperture of the fiber optics used in light conduit 340 may be chosen to match the aperture of the

fiber optics for the light source and the light receivers. Thus, the central part of the light conduit may conduct light from the light source and illuminate the surface as if it constituted a single fiber within a bundle of fibers. Similarly, the outer portion of the light conduit may receive reflected light and conduct it to light receiver fiber optics as if it constituted single fibers. Light conduit 340 has ends that preferably are highly polished and cut perpendicular, particularly the end coupling light to fiber optics 346. Similarly, the end of fiber optics 346 abutting light conduit 340 also is highly polished and cut perpendicular to a high degree of accuracy in order to minimize light reflection and cross talk between the light source fiber optic and the light receiver fiber optics and between adjacent receiver fiber optics. Light conduit 340 offers significant advantages including in the manufacture and installation of such a removable tip. For example, the probe tip need not be particularly aligned with the probe tip holder; rather, it only needs to be held against the probe tip holder such as with a compression mechanism (such as with compression jaws 342) so as to couple light effectively to/from fiber optics 346. Thus, such a removable tip mechanism may be implemented without alignment tabs or the like, thereby facilitating easy installation of the removable probe tip. Such an easy installable probe tip may thus be removed and cleaned prior to installation, thereby facilitating use of the color/optical measuring apparatus by dentists, medical professions or others working in an environment in which contamination may be a concern. Light conduit 340 also may be implemented, for example, as a small section of light conduit, which may facilitate easy and low cost mass production and the like.

[0165] A further embodiment of such a light conduit probe tip is illustrated as light conduit 352 in FIG. 23C. Light conduit 352 is a light conduit that is narrower on one end (end 354) than the other end (end 356). Contoured/tapered light conduits such as light conduit 352 may be fabricated by heating and stretching a bundle of small fiber optics as part of the fusing process. Such light conduits have an additional interesting property of magnification or reduction. Such phenomena result because there are the same number of fibers in both ends. Thus, light entering narrow end 354 is conducted to wider end 356, and since wider end 356 covers a larger area, it has a magnifying affect.

[0166] Light conduit 352 of FIG. 23C may be utilized in a manner similar to light conduit 340 (which in general may be cylindrical) of FIG. 23A. Light conduit 352, however, measures smaller areas because of its reduced size at end 354. Thus, a relatively larger probe body may be manufactured where the source fiber optic is spaced widely from the receiver fiber optics, which may provide an advantage in reduced light reflection and cross talk at the junction, while still maintaining a small probe measuring area. Additionally, the relative sizes of narrow end 354 of light conduit 352 may be varied. This enables the operator to select the size/characteristic of the removable probe tip according to the conditions in the particular application. Such ability to select sizes of probe tips provides a further advantage in making optical characteristics measurements in a variety of applications and operative environments.

[0167] As should be apparent to those skilled in the art in view of the disclosures herein, light conduits 340 and 356 of FIGS. 23A and 23C need not necessarily be cylindrical/tapered as illustrated, but may be curved such as for specialty applications, in which a curved probe tip may be advanta-

geously employed (such as in a confined or hard-to-reach place). It also should be apparent that light conduit 352 of FIG. 23C may be reversed (with narrow end 354 coupling light into fiber optics 346, etc., and wide end 356 positioned in order to take measurements) in order to cover larger areas.

[0168] Referring now to FIG. 24, a further embodiment of the present invention will be explained.

[0169] Intraoral reflectometer 380, which may be constructed as described above, includes probe 381. Data output from reflectometer 380 is coupled to computer 384 over bus 390 (which may be a standard serial or parallel bus, etc.). Computer 384 includes a video freeze frame capability and preferably a modem. Intraoral camera 382 includes hand-piece 383 and couples video data to computer 384 over bus 392. Computer 384 is coupled to remote computer 386 over telecommunication channel 388, which may be a standard telephone line, ISDN line, a LAN or WAN connection, etc. With such an embodiment, video measurements may be taken of one or more teeth by intraoral camera 382, along with optical measurements taken by intraoral reflectometer 380. Computer 384 may store still picture images taken from the output of intraoral camera 382.

[0170] Teeth are known to have variations in color from tooth to tooth, and teeth are known to have variations in color over the area of one tooth. Intraoral cameras are known to be useful for showing the details of teeth. Intraoral cameras, however, in general have poor color reproducibility. This is due to variations in the camera sensing elements (from camera to camera and over time etc.), in computer monitors, printers, etc. As a result of such variations, it presently is not possible to accurately quantify the color of a tooth with an intraoral camera. With the present embodiment, measuring and quantifying the color or other optical properties of teeth may be simplified through the use of an intraoral reflectometer in accordance with the present invention, along with an intraoral camera.

[0171] In accordance with this embodiment, the dentist may capture a still picture of a tooth and its adjacent teeth using the freeze frame feature of computer 384. Computer 384, under appropriate software and operator control, may then "postureize" the image of the tooth and its adjacent teeth, such as by limiting the number of gray levels of the luminance signal, which can result in a color image that shows contours of adjacent color boundaries. As illustrated in FIG. 25, such a postureization process may result in teeth 396 being divided into regions 398, which follow color contours of teeth 396. As illustrated, in general the boundaries will be irregular in shape and follow the various color variations found on particular teeth.

[0172] With teeth postureized as illustrated in FIG. 25, computer 384 may then highlight (such as with a colored border, shading, highlight or the like) a particular color region on a tooth to be measured, and then the dentist may then measure the highlighted region with intraoral reflectometer 380. The output of intraoral reflectometer 380 is input to computer 384 over bus 390, and computer 384 may store in memory or on a hard disk or other storage medium the color/optical data associated with the highlighted region. Computer 384 may then highlight another region and continue the process until color/optical data associated with all desired highlighted regions have been stored in computer 384. Such color/optical data may then be stored in a suitable data base, along with the video image and postureized video image of the particular teeth, etc.

[0173] Computer 384 may then assess if the measured value of a particular color region is consistent with color measurements for adjacent color regions. If, for example, a color/optical measurement for one region indicates a darker region as compared to an adjacent region, but the postureized image indicates that the reverse should be true, then computer 384 may notify the dentist (such as with an audio tone) that one or more regions should be re-measured with intraoral reflectometer 380. Computer 384 may make such relative color determinations (even though the color values stored in computer 384 from the freeze frame process are not true color values) because the variations from region to region should follow the same pattern as the color/optical measurements taken by intraoral reflectometer 380. Thus, if one region is darker than its neighbors, then computer 384 will expect that the color measurement data from intraoral reflectometer 380 for the one region also will be darker relative to color measurement data for the neighboring regions, etc.

[0174] As with the color measurement data and captured images discussed previously, the postureized image of the teeth, along with the color/optical measurement data for the various regions of the teeth, may be conveniently stored, maintained and accessed as part of the patient dental records. Such stored data may be utilized advantageously in creating dental prosthesis that more correctly match the colors/regions of adjacent teeth.

[0175] In a further refinement to the foregoing embodiment, computer 384 preferably has included therein, or coupled thereto, a modem. With such a modem capability (which may be hardware or software), computer 384 may couple data to remote computer 386 over telecommunication channel 388. For example, remote computer 386 may be located at a dental laboratory remotely located. Video images captured using intraoral camera 382 and color/optical data collected using intraoral reflectometer may be transmitted to a dental technician (for example) at the remote location, who may use such images and data to construct dental prosthesis. Additionally, computer 384 and remote computer 386 may be equipped with an internal or external video teleconference capability, thereby enabling a dentist and a dental technician or ceramist, etc., to have a live video or audio teleconference while viewing such images and/or data.

[0176] For example, a live teleconference could take place, whereby the dental technician or ceramist views video images captured using intraoral camera 383, and after viewing images of the patient's teeth and facial features and complexion, etc., instruct the dentist as to which areas of the patient's teeth are recommended for measurement using intraoral reflectometer 380. Such interaction between the dentist and dental technician or ceramist may occur with or without postureization as previously described. Such interaction may be especially desirable at, for example, a try-in phase of a dental prosthesis, when minor changes or subtle characterizations may be needed in order to modify the prosthesis for optimum esthetic results.

[0177] A still further refinement may be understood with reference to FIG. 26. As illustrated in FIG. 26, color calibration chart 404 could be utilized in combination with various elements of the previously described embodiments, including intraoral camera 382. Color calibration chart 404 may provide a chart of known color values, which may be employed, for example, in the video image to further enhance correct skin tones of patient 402 in the displayed video image. As the patient's gingival tissue, complexion and facial features, etc.,

may influence the final esthetic results of a dental prosthesis, such a color calibration chart may be desirably utilized to provide better esthetic results.

[0178] As an additional example, such a color calibration chart may be utilized by computer **384** and/or **386** to “calibrate” the color data within a captured image to true or known color values. For example, color calibration chart **404** may include one or more orientation markings **406**, which may enable computers **384** and/or **386** to find and position color calibration chart **404** within a video frame. Thereafter, computers **384** and/or **386** may then compare “known” color data values from color calibration chart (data indicative of the colors within color calibration chart **404** and their position relative to orientation mark or markings **406** are stored within computers **384** and/or **386**, such as in a lookup table, etc.) with the colors captured within the video image at positions corresponding to the various colors of color calibration chart **404**. Based on such comparisons, computers **384** and/or **386** may color adjust the video image in order to bring about a closer correspondence between the colors of the video image and known or true colors from color calibration chart **404**.

[0179] In certain embodiments, such color adjusted video data may be used in the prosthesis preparation process, such as to color adjust the video image (whether or not post-processed) in conjunction with color/optical data collected using intraoral reflectometer **380** (for example, as described above or using data from intraoral reflectometer **380** to further color adjust portions of the video image), or to add subtle characterizations or modifications to a dental prosthesis, or to even prepare a dental prosthesis, etc. While not believed to be as accurate, etc. as color/optical data collected using intraoral reflectometer **380**, such color adjusted video data may be adequate in certain applications, environments, situations, etc., and such color adjusted video data may be utilized in a similar manner to color data taken by a device such as intraoral reflectometer **380**, including, for example, prosthesis preparation, patient data collection and storage, materials preparation, such as described elsewhere herein.

[0180] It should be further noted that color calibration chart **404** may be specifically adapted (size, form and constituent materials, etc.) to be positioned inside of the patient’s mouth to be placed near the tooth or teeth being examined, so as to be subject to the same or nearly the same ambient lighting and environmental conditions, etc., as is the tooth or teeth being examined. It also should further be noted that the utilization of color calibration chart **404** to color correct video image data with a computer as provided herein also may be adapted to be used in other fields, such as medical, industrial, etc., although its novel and advantageous use in the field of dentistry as described herein is of particular note and emphasis herein.

[0181] FIG. 27 illustrates a further embodiment of the present invention, in which an intraoral reflectometer in accordance with the present invention may be adapted to be mounted on, or removably affixed to, a dental chair. An exemplary dental chair arrangement in accordance with the present invention includes dental chair **410** is mounted on base **412**, and may include typical accompaniments for such chairs, such as foot control **414**, hose(s) **416** (for suction or water, etc.), sink and water supply **420** and light **418**. A preferably movable arm **422** extends out from support **428** in order to provide a conveniently locatable support **430** on which various dental instruments **424** are mounted or affixed in a removable manner. Tray **426** also may be included, on which a

dentist may position other instruments or materials. In accordance with this embodiment, however, instruments **424** include an intraoral reflectometer in accordance with the present invention, which is conveniently positioned and removably mounted/affixed on support **430**, so that color/optical measurements, data collection and storage and prosthesis preparation may be conveniently carried out by the dentist. As opposed to large and bulky prior art instruments, the present invention enables an intraoral reflectometer for collecting color/optical data, in some embodiments combined or utilized with an intraoral camera as described elsewhere herein, which may be readily adapted to be positioned in a convenient location on a dental chair. Such a dental chair also may be readily adapted to hold other instruments, such as intraoral cameras, drills, lights, etc.

[0182] Additionally, and to emphasize the wide utility and variability of various of the inventive concepts and techniques disclosed herein, it should be apparent to those skilled in the art in view of the disclosures herein that the apparatus and methodology may be utilized to measure the optical properties of objects/teeth using other optical focusing and gathering elements, in addition to the fiber optics employed in preferred embodiments herein. For example, lenses or mirrors or other optical elements may also be utilized to construct both the light source element and the light receiver element. A flashlight or other commonly available light source, as particular examples, may be utilized as the light source element, and a common telescope with a photoreceiver may be utilized as the receiver element in a large scale embodiment of the invention. Such refinements utilizing teachings provided herein are expressly within the scope of the present invention.

[0183] As will be apparent to those skilled in the art, certain refinements may be made in accordance with the present invention. For example, a central light source fiber optic is utilized in certain preferred embodiments, but other light source arrangements (such as a plurality of light source fibers, etc.). In addition, lookup tables are utilized for various aspects of the present invention, but polynomial type calculations could similarly be employed. Thus, although various preferred embodiments of the present invention have been disclosed for illustrative purposes, those skilled in the art will appreciate that various modifications, additions and/or substitutions are possible without departing from the scope and spirit of the present invention as disclosed in the claims.

[0184] Reference is also made to copending international application filed on even date herewith under the Patent Cooperation Treaty, for “Apparatus and Method for Measuring Optical Characteristics of an Object,” by the inventors hereof, which is hereby incorporated by reference.

What is claimed is:

1. A method including the determination of shade information of an object, comprising the steps of:
 - determining color information of the object, wherein the color information is determined by:
 - generating data of the object with an image generation device having a field of view, wherein the and a reference implement having one or more regions of predetermined optical properties are positioned in the field of view of the image generation device, wherein the reference implement is positioned near the object;
 - generating data of the reference implement with the image generation device, wherein the reference implement includes a positional location attribute, wherein based on the positional location attribute a

position of the one or more regions of predetermined optical properties of the reference implement in the field of view of the image generation device is determined by a processing system without operator identification of the position in the field of view of the image generation device;

generating color information of the object by adjusting the data generated of the object based on the data generated of the reference implement; and

determining shade information of the object, wherein the color information is used to determine a closest match or matches of shade values in one or more regions of the object, wherein data for the shade values are stored in memory accessed by the processing system.

2. The method of claim 1, wherein the color information comprises value, chroma and hue information.

3. The method of claim 1, wherein the color information comprises RGB values, XYZ coordinates, or Lab values.

4. The method of claim 1, wherein the shade information is transmitted electronically to a remote location.

5. The method of claim 4, wherein the shade information is transmitted via a telecommunication channel.

6. The method of claim 4, wherein the shade information is transmitted via a LAN or WAN.

7. The method of claim 1, wherein the object comprises human skin.

8. The method of claim 7, wherein the shade information is used to electronically output a proposed material or materials.

9. The method of claim 1, wherein an image of the object is displayed, wherein data indicative of the shade information of the object in one or more particular regions is displayed in an overlaid manner over the one or more particular regions.

10. The method of claim 1, wherein the object and the reference implement are positioned so as to be subject to a substantially corresponding lighting condition.

11. A method including the determination of color information of an object, comprising the steps of:

determining color information of the object, wherein the color information is determined by:

generating data of the object with an image generation device having a field of view, wherein the object and a reference implement having one or more regions of

predetermined optical properties are positioned in the field of view of the image generation device, wherein the reference implement is adapted to be positioned near the object;

generating data of the reference implement with the image generation device, wherein the reference implement includes a positional location attribute, wherein based on the positional location attribute a position of the one or more regions of predetermined optical properties of the reference implement in the field of view of the image generation device is determined by a processing system without operator identification of the position of the reference implement in the field of view of the image generation device;

generating color information of the object by adjusting the data generated of the object based on the data generated of the reference implement; and

outputting the color information of the object for one or more regions of the object.

12. The method of claim 11, wherein the color information comprises value, chroma and hue information.

13. The method of claim 11, wherein the color information comprises RGB values, XYZ coordinates, or Lab values.

14. The method of claim 11, wherein the color information is transmitted electronically to a remote location.

15. The method of claim 14, wherein the color information is transmitted via a telecommunication channel.

16. The method of claim 14, wherein the color information is transmitted via a LAN or WAN.

17. The method of claim 11, wherein the object comprises human skin.

18. The method of claim 17, wherein the color information is used to electronically output a proposed material or materials.

19. The method of claim 11, wherein an image of the object is displayed, wherein data indicative of the color information of the object in one or more particular regions is displayed in an overlaid manner over the one or more particular regions.

20. The method of claim 11, wherein the object and the reference implement are positioned so as to be subject to a substantially corresponding lighting condition.

* * * * *