



US 20130255452A1

(19) **United States**

(12) **Patent Application Publication**
Kovach

(10) **Pub. No.: US 2013/0255452 A1**

(43) **Pub. Date: Oct. 3, 2013**

(54) **DRAIN REMOVAL TOOL**

(71) Applicant: **Superior Tool Corp.**, Cleveland, OH (US)

(72) Inventor: **James A. Kovach**, Parma, OH (US)

(21) Appl. No.: **13/627,773**

(22) Filed: **Sep. 26, 2012**

Related U.S. Application Data

(60) Provisional application No. 61/539,095, filed on Sep. 26, 2011.

Publication Classification

(51) **Int. Cl.**
B25B 13/50 (2006.01)

(52) **U.S. Cl.**

CPC **B25B 13/5083** (2013.01)

USPC **81/443**

(57) **ABSTRACT**

A drain removal tool with a central opening aligned along a central tool axis, a holding section with a hex head for applying torque to the tool, and an engagement section including elongate sharp ridges or teeth extending in a helical pattern from an external surface of the engagement section from the tool for engagement with the drain to be removed. Each elongate sharp ridge has one flat face and a ramp face. Each flat face is aligned along a radius extending outwardly from the central tool axis. The ridges are spaced such that the distance between each flat face is approximately 6 degrees. Each helical ridge is a left hand helical serration on a 15 degree pitch with respect to the central axis of the central opening. The holding section includes a hex head configuration. The central opening in the holding section has a hex configuration.

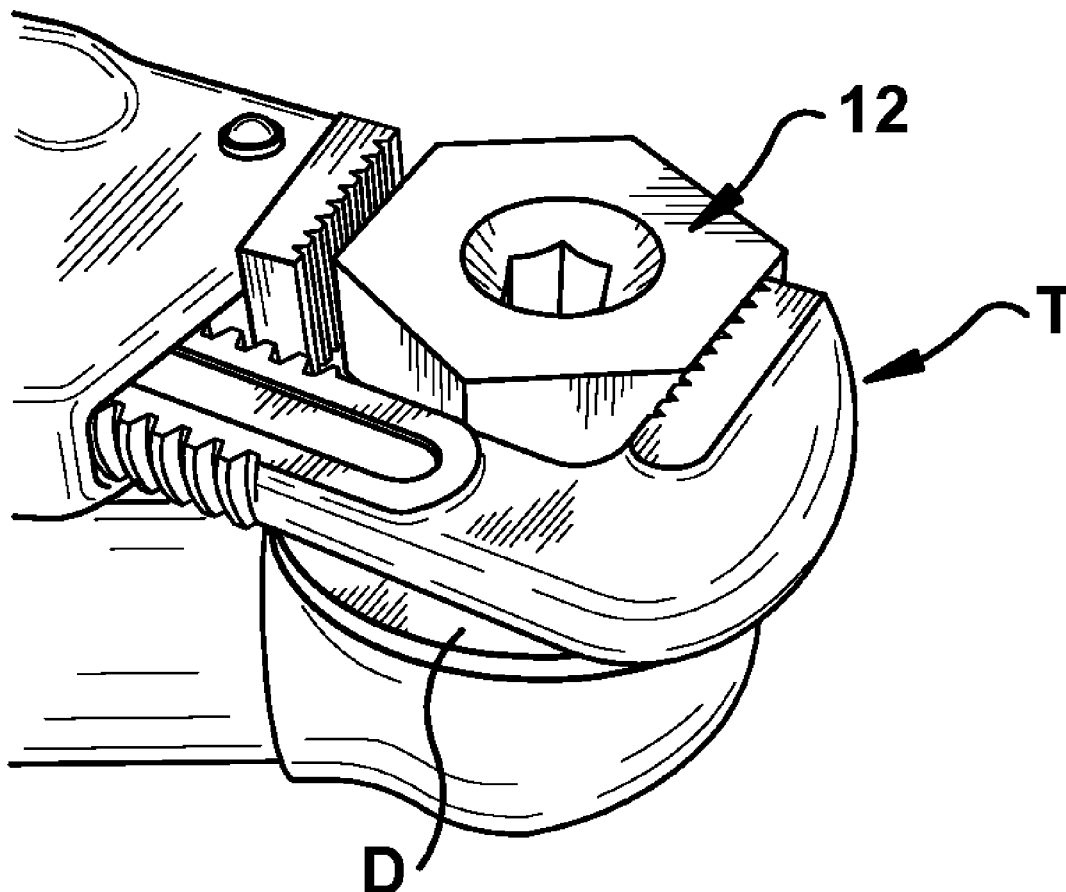

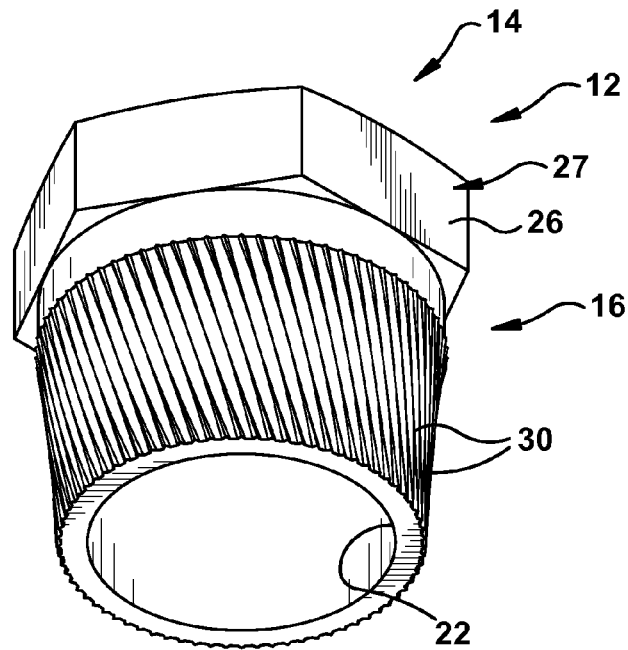

Figure 1

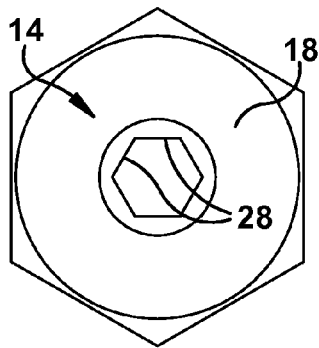

Figure 2

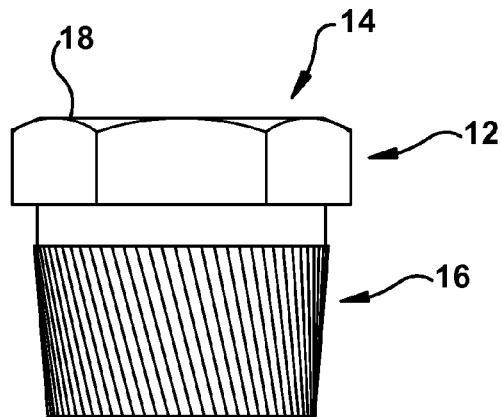

Figure 3

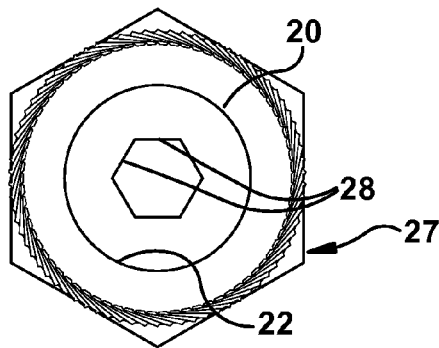

Figure 4

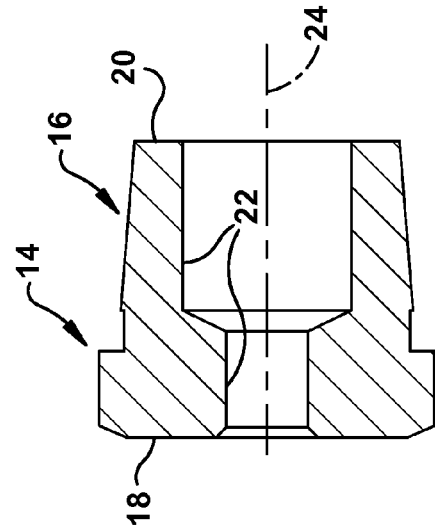

Figure 5

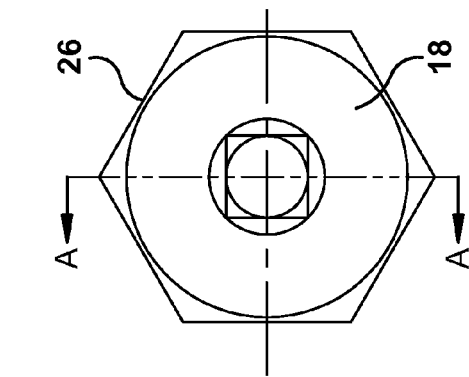
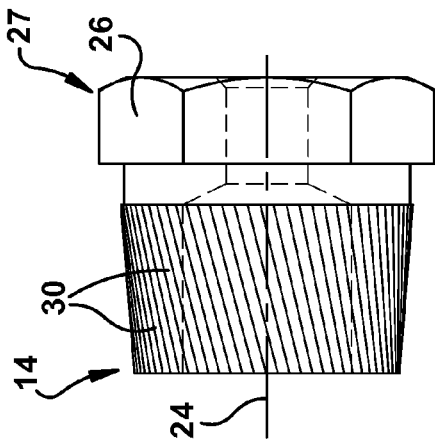

Figure 6



SECT. A-A
Figure 7

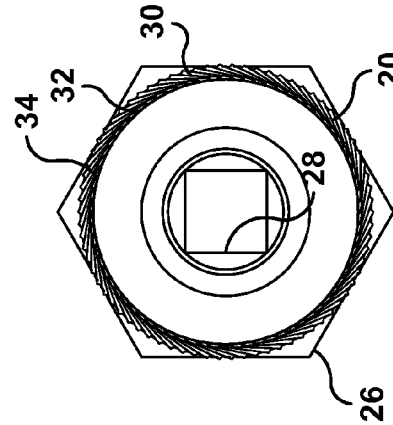

Figure 8

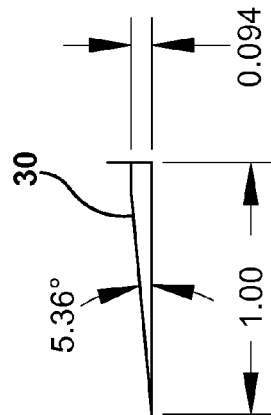

Figure 9

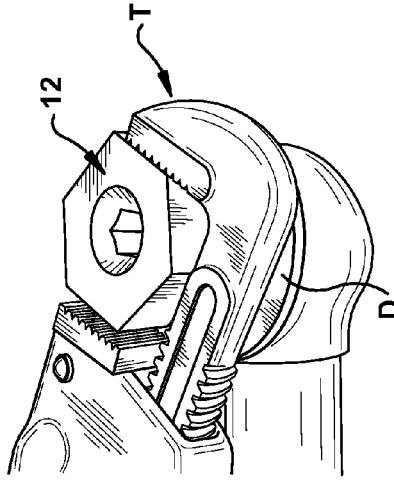

Figure 10B

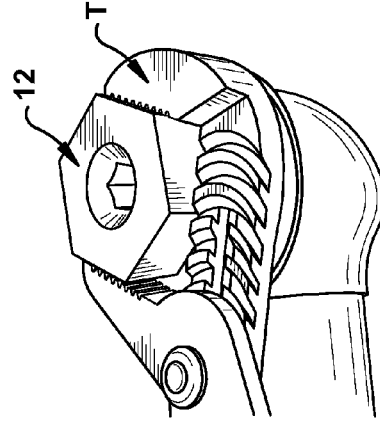

Figure 10D

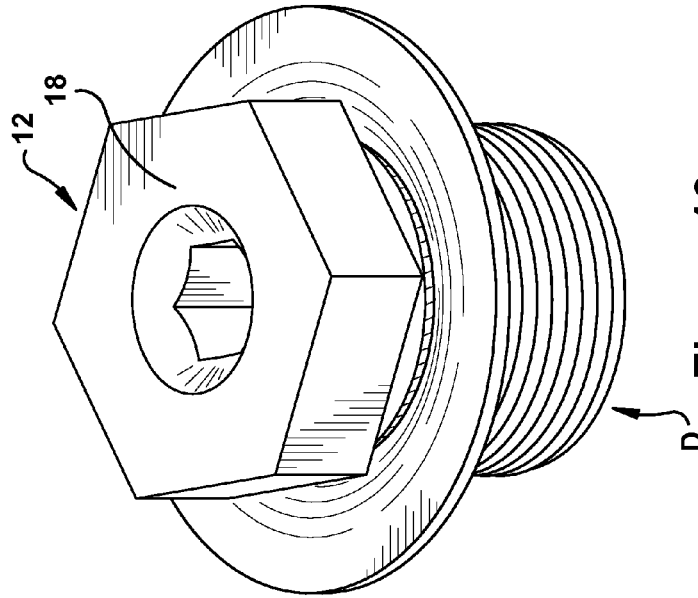

Figure 10

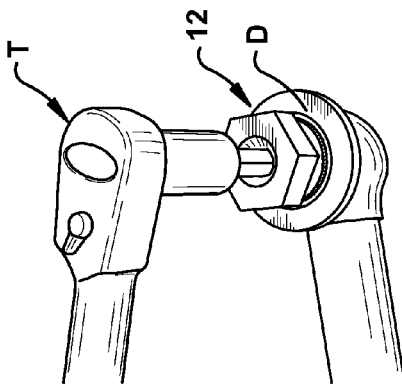

Figure 10A

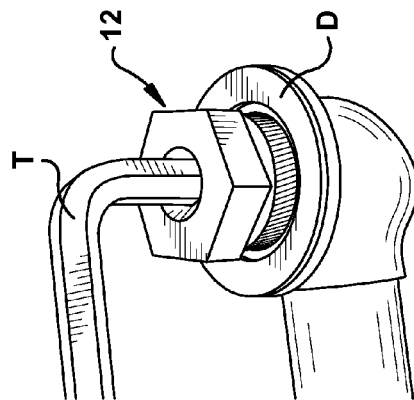

Figure 10C

DRAIN REMOVAL TOOL

PRIORITY CLAIM

[0001] This application claims priority from pending provisional patent application Ser. No. 61/539,095 filed on Sep. 26, 2011, the subject matter of which is incorporated herein by reference in its entirety.

TECHNICAL FIELD

[0002] The present application is directed to a tool for removing an existing drain from a tub, shower or sink fixture.

BACKGROUND

[0003] Removing a drain from a tub, shower or sink fixture can be difficult when the drain has significant deterioration due to age. In particular, when the crosshairs on the old drain are corroded and/or missing, the many available prior art drain removal tools may not be sufficient to remove the drain. When prior art tools fail to remove the drain, extreme measures are often taken, such as hammering or chiseling the drain to assist with removal. Such extreme measures increase the risk that the surface of the tub, shower or sink may be damaged or cracked in order to successfully remove the drain.

SUMMARY OF THE INVENTION

[0004] The present application is for a new and improved drain removal tool. The removal tool of this application may be of any iron, steel or equivalent metal material, conveniently manufactured from hex stock material. The tool includes a holding section and an engagement section. The holding section has a top hammer surface. The engagement section includes a bottom surface, and a central opening having a central axis which passes through the tool between the top hammer surface of the holding section and the bottom surface of the engagement section. The holding section is also provided with additional surface configurations for gripping the tool and applying torque during drain removal.

[0005] The engagement section of the removal tool is provided with ridges or pointed teeth, extending outwardly from the surface of the engagement section. The ridges or teeth are arranged in a helical pattern along the engagement section, with each helical tooth or serration being a left hand helical serration on a 15 degree pitch with respect to the central axis of the central opening. Each tooth has one flat face, which flat face is aligned along a radius extending outwardly from the central axis, and a ramped face. The teeth are spaced such that the distance between the flat face of each tooth is approximately 6 degrees, with the helical arrangement and pitch of the teeth resulting in an angled or knurled configuration to the engagement section, with the engagement portion of the tool at the top of the teeth having a larger external diameter than the external diameter of the bottom portion of the engagement section.

[0006] To use the drain removal tool, the tool is dropped or placed into the old drain to be removed. The top surface of the tool may be hammered, or simply pressed, such that the pointed teeth contact the drain. Next, a pipe wrench, locking plier, fixed wrench or other torque applying tool is mounted or engaged with the holding section, and a torque is applied to turn the tool counter clockwise. The more torque that is applied to the drain removal tool to the holding section, the more the teeth of the engagement section will bite, or engage into, the drain, enabling the drain to be removed. Slippage or

displacement of the tool within the drain is minimized as a result of the teeth along the engagement section.

BRIEF DESCRIPTION OF THE DRAWINGS

[0007] The attached figures illustrate non-restrictive examples of the tool device of the present application. The figures include:

[0008] FIG. 1 is a perspective view of the drain removal tool of the present application;

[0009] FIGS. 2 and 6 are top views of the design of FIG. 1;

[0010] FIGS. 3 and 5 are side views of the design of FIG. 1;

[0011] FIG. 4 is a bottom view of the tool of FIG. 1;

[0012] FIG. 7 is a cross-sectional side view of the tool, taken along the line A-A of FIG. 6;

[0013] FIG. 8 is an enlarged view of a helical tooth of the tool of FIG. 5;

[0014] FIG. 9 is a partial conceptual view of the bottom of the tool of FIG. 5;

[0015] FIG. 10 illustrates the drain removal tool engaged within a drain which has been removed from the tub or sink; and

[0016] FIGS. 10A, 10B, 10C and 10D each illustrate an alternate method by which the drain removal tool may be used to remove a drain.

DETAILED DESCRIPTION

[0017] As shown in FIG. 1, the present application provides a new and improved drain removal tool 12. The drain removal tool device is desirable when the crosshairs on your old sink, tub or shower fixture drain are corroded and/or missing and other prior art drain removal tools fail. The present tool 12 is able to remove stubborn drains which resist removal. There is no need to use a chisel and hammer to remove the drain, which risks surface damage or cracking of the fixture. The helical knurled aspect of the present device avoids a number of problems.

[0018] The drain removal tool 12 of this application may be of any iron, steel or equivalent metal material, but is preferably of hardened steel, such as 12L14 steel, with a black oxide finish. Further, as shown in FIGS. 2-4 and 6-10, the tool may be conveniently manufactured from hex stock material, for example, 1.75 inch hex stock in the illustrated embodiment. The tool 12 includes a holding section 14 and an engagement section 16. The holding section 14 has a top hammer surface 18. The engagement section 16 includes a bottom surface 20. A central opening 22 with a central axis 24 passes through the tool 12 between the top hammer surface 18 of the holding section 14 and the bottom surface 20 of the engagement section 16. The holding section 14 is also provided with numerous additional surfaces for gripping the tool and applying torque during drain removal. First, external surfaces 26 of the holding section 14 form a hex head 27, which is approximately 0.5 inches in height, for engagement by an adjustable wrench, pipe wrench or other gripping tool, such as ViseGrip® pliers. Second, within the holding section, along the central opening 22, internal surfaces 28 are provided for engagement by either an Allen® wrench or other adjustable socket wrench. In FIGS. 2-4, the internal surfaces 28 form a hex configuration for receiving a mating wrench. In FIGS. 6 and 9, the internal surfaces 28' form a square configuration receiving for a mating wrench, such as a ratchet wrench or extension. In these embodiments the central opening 22 is shown as extending through the entire tool 12 from the top

hammer surface **18** to the bottom surface **20** of the engagement section **16**. A central opening extending through the entire tool is optional. Alternative torque applying tools for use with the tool holding section are illustrated, for example, in FIGS. **10A** to **10D**.

[0019] The engagement section **16** of the removal tool **12** is provided with ridges or pointed teeth **30**, extending outwardly from the surface of engagement section. The portion of the engagement section **16** supporting the teeth **30** has a height of approximately 1 inch from the bottom surface **20** to the top of the teeth. The ridges or teeth **30** are arranged in a helical pattern along the engagement section **16**, each helical tooth or serration being a left hand helical serration on a 15 degree pitch with respect to the central axis **24** of the central opening **22**. As shown in FIG. **8**, each tooth **30** begins at the bottom surface **20** of the engagement section **16**, and ramps to a height of approximately 0.094 inches. In other words, the external diameter of the engagement section **16** adjacent the bottom surface **20** is approximately 1.562 inches, and the external diameter of the engagement section at its widest location at the top of the teeth **30** is approximately 1.75 inches. Each tooth has one flat face **32**, which flat face **32** is aligned along a radius extending outwardly from the central axis **22**, and a ramped face **34**, which extends out of the engagement portion **16** at approximately 5.36 degrees with respect to the central axis. The teeth **30** are spaced such that the distance between each tooth flat face **32** is approximately 6 degrees. As shown, the helical arrangement and pitch of the teeth **30** results in an angled or knurled configuration to the engagement section **16**, with the portion of the tool **12** at the top of the teeth **30** having a larger external diameter than the external diameter adjacent the bottom surface of the engagement section.

[0020] To use the drain removal tool **12**, the tool is dropped or placed into the old drain **D** to be removed. The top hammer surface **18** of the tool may be hammered, or simply pressed, such that the pointed teeth **30** contact the drain **D**. Next, a pipe wrench, locking pliers, an Allen wrench or other torque applying tool **T** is mounted or engaged with the holding section **14**, and torque is applied to turn the tool counter clockwise. The more torque that is applied to the drain removal tool, the more the teeth **30** of the engagement section **16** will bite, or engage into, the drain, enabling the drain to be turned and removed. Slippage of the tool **12** within the drain **D** is minimized due to the engaged teeth **30** along the engagement section **16**.

[0021] While the preferred embodiments of the drain removal tool **12** have been illustrated and described, it should be understood that variations will become apparent to those skilled in the art.

[0022] Accordingly, the invention is not to be limited to the specific embodiments illustrated and described herein, but rather the true scope and spirit of the invention are to be determined by reference to the appended claims.

I claim:

1. A drain removal tool having a central opening aligned along a central tool axis, a holding section for applying torque to the tool, and an engagement section including sharp teeth extending from the tool for engagement with the drain to be removed.

2. The drain removal tool of claim **1**, wherein the sharp teeth are elongate ridges in a helical pattern on an external surface of the engagement section of the tool.

3. The drain removal tool of claim **2**, wherein each elongate ridge has one flat face, which flat face is aligned along a radius extending outwardly from the central tool axis, and a ramped face.

4. The drain removal tool of claim **3**, wherein the teeth are spaced such that the distance between each flat face is approximately 6 degrees.

5. The drain removal tool of claim **2**, wherein the each helical tooth is a left hand helical serration on a 15 degree pitch with respect to the central axis of the central opening.

6. The drain removal tool of claim **2**, wherein the holding section includes a hex head configuration.

7. The drain removal tool of claim **2**, wherein the central opening in the holding section is a hex configuration.

8. The drain removal tool of claim **2**, wherein the central opening in the holding section is a square configuration.

9. A drain removal tool having a central opening aligned along a central tool axis, a holding section for applying torque to the tool, and an engagement section including elongate sharp ridges extending in a helical pattern from an external surface of the engagement section from the tool for engagement with the drain to be removed.

10. The drain removal tool of claim **9**, wherein each elongate sharp ridge has one flat face, which flat face is aligned along a radius extending outwardly from the central tool axis, and a ramped face.

11. The drain removal tool of claim **10**, wherein the ridges are spaced such that the distance between each flat face is approximately 6 degrees.

12. The drain removal tool of claim **11**, wherein the each helical ridge is a left hand helical serration on a 15 degree pitch with respect to the central axis of the central opening.

13. The drain removal tool of claim **12**, wherein the holding section includes a hex head configuration.

14. The drain removal tool of claim **13**, wherein the central opening in the holding section is a hex configuration.

15. A drain removal tool having a central opening aligned along a central tool axis, a holding section having a hex head for applying torque to the tool, and an engagement section including elongate sharp ridges extending in a helical pattern from an external surface of the engagement section from the tool for engagement with the drain to be removed, and each elongate sharp ridge has one flat face, which flat face is aligned along a radius extending outwardly from the central tool axis, and a ramped face.

16. The drain removal tool of claim **15**, wherein the ridges are spaced such that the distance between each flat face is approximately 6 degrees.

17. The drain removal tool of claim **16**, wherein the each helical ridge is a left hand helical serration on a 15 degree pitch with respect to the central axis of the central opening.

18. The drain removal tool of claim **17**, wherein the holding section includes a hex head configuration.

19. The drain removal tool of claim **18**, wherein the central opening in the holding section is a hex configuration.

* * * * *