



US 20130314295A1

(19) **United States**

(12) **Patent Application Publication**
Breslin et al.

(10) **Pub. No.: US 2013/0314295 A1**

(43) **Pub. Date: Nov. 28, 2013**

(54) **MULTI-CHANNEL RX/TX CALIBRATION AND LOCAL OSCILLATOR MISMATCH MITIGATION**

Publication Classification

(71) Applicant: **QUALCOMM Incorporated**, San Diego, CA (US)

(51) **Int. Cl.**
H01Q 21/29 (2006.01)

(72) Inventors: **Donald Breslin**, Sunnyvale, CA (US);
Jeffrey M. Gilbert, Sunnyvale, CA (US)

(52) **U.S. Cl.**
CPC **H01Q 21/29** (2013.01)
USPC **343/853**

(73) Assignee: **QUALCOMM Incorporated**, San Diego, CA (US)

(57) **ABSTRACT**

(21) Appl. No.: **13/957,294**

A method and system of optimizing transmit beam forming in a multiple radio wireless system is provided. A stimulus signal can be provided to an analog receive input of a device under test (DUT), wherein the DUT includes multiple radios. A receive phase and amplitude can be measured at baseband using the stimulus signal for each radio. At this point, a receive weight and its conjugate can be determined using the receive phases and amplitudes. A calibration vector and its conjugate can also be determined, wherein a product of the receive weight conjugate and the calibration vector conjugate generate a transmit weight. This transmit weight can be applied to transmit signals during the transmit beam forming using the multiple radios.

(22) Filed: **Aug. 1, 2013**

Related U.S. Application Data

(62) Division of application No. 12/942,659, filed on Nov. 9, 2010, now Pat. No. 8,532,598, which is a division of application No. 11/613,977, filed on Dec. 20, 2006, now Pat. No. 7,853,216.

(60) Provisional application No. 60/753,795, filed on Dec. 22, 2005.

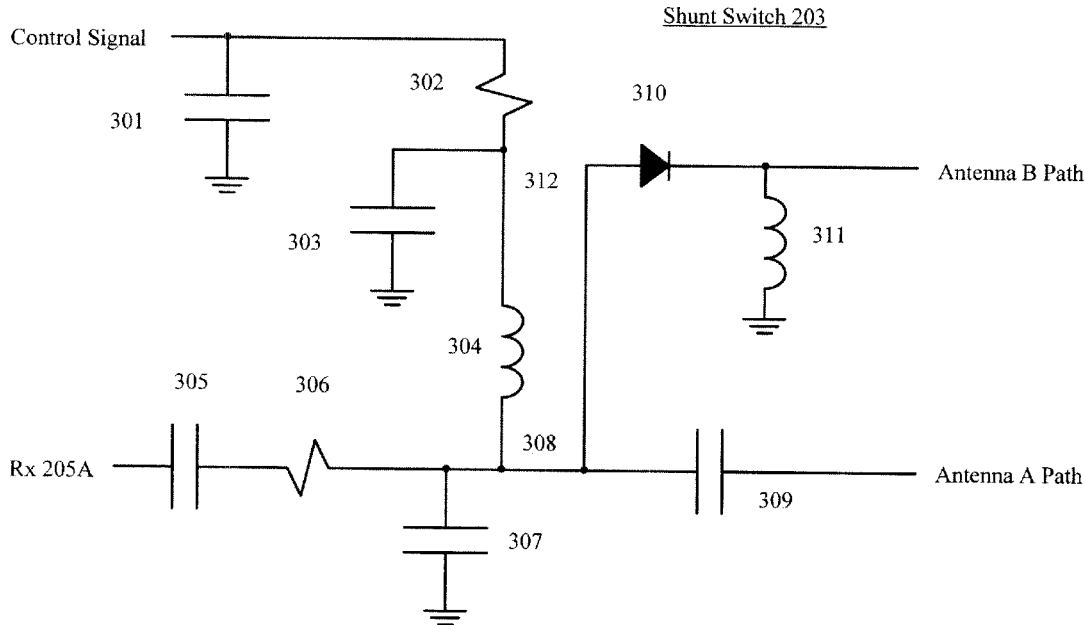

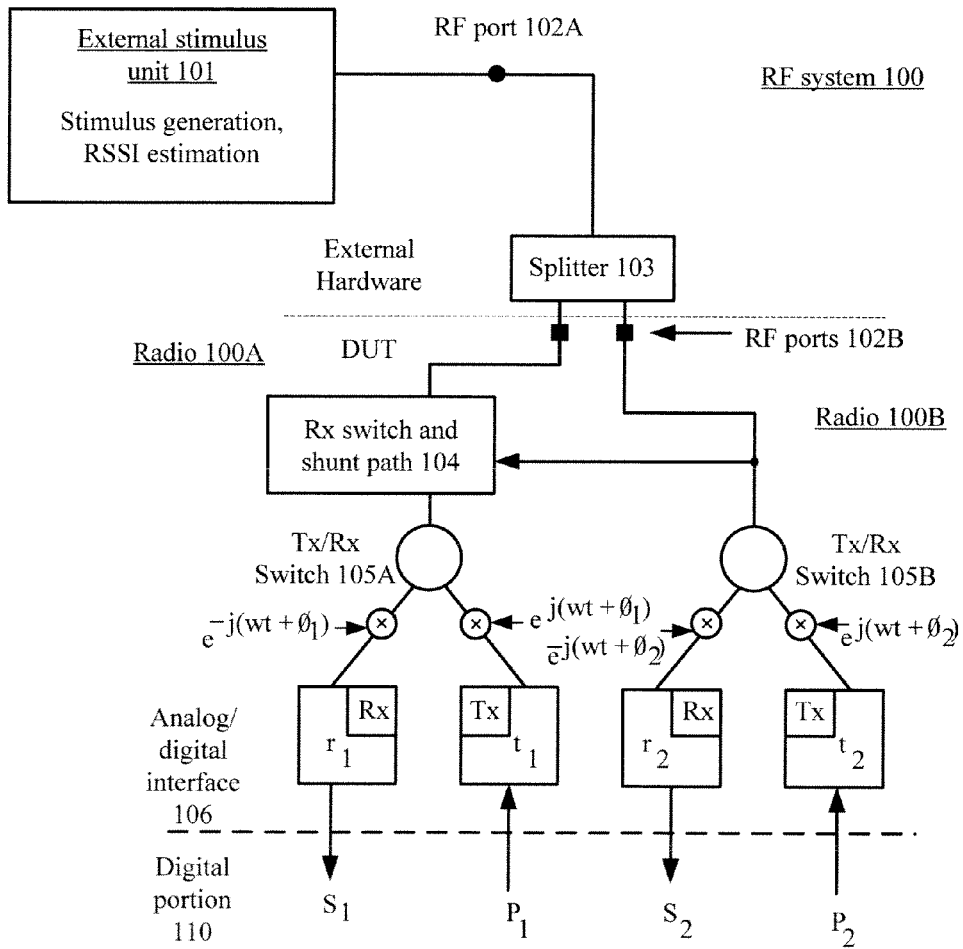

FIG. 1A

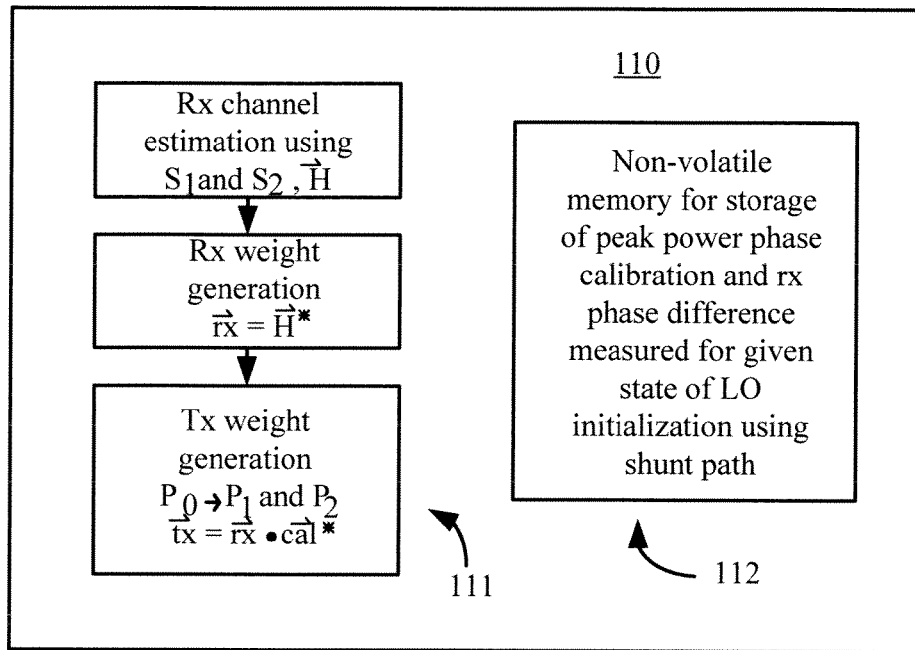

FIG. 1B

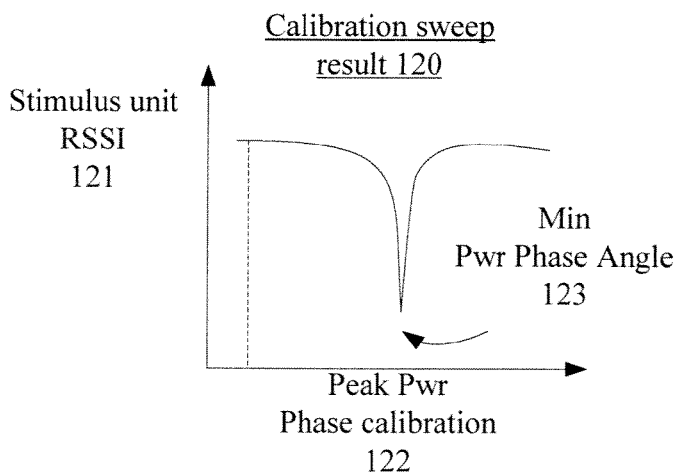
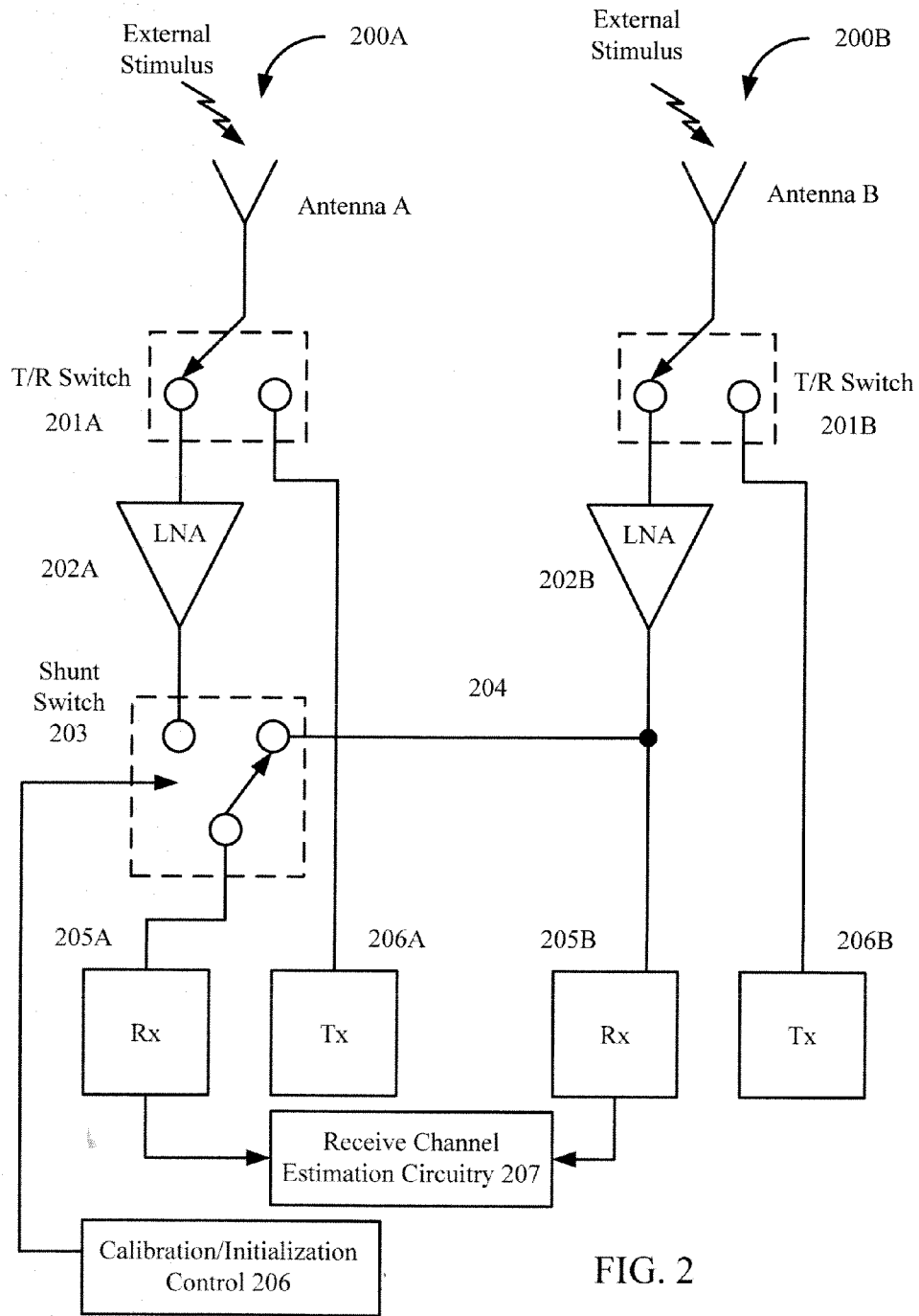

FIG. 1C



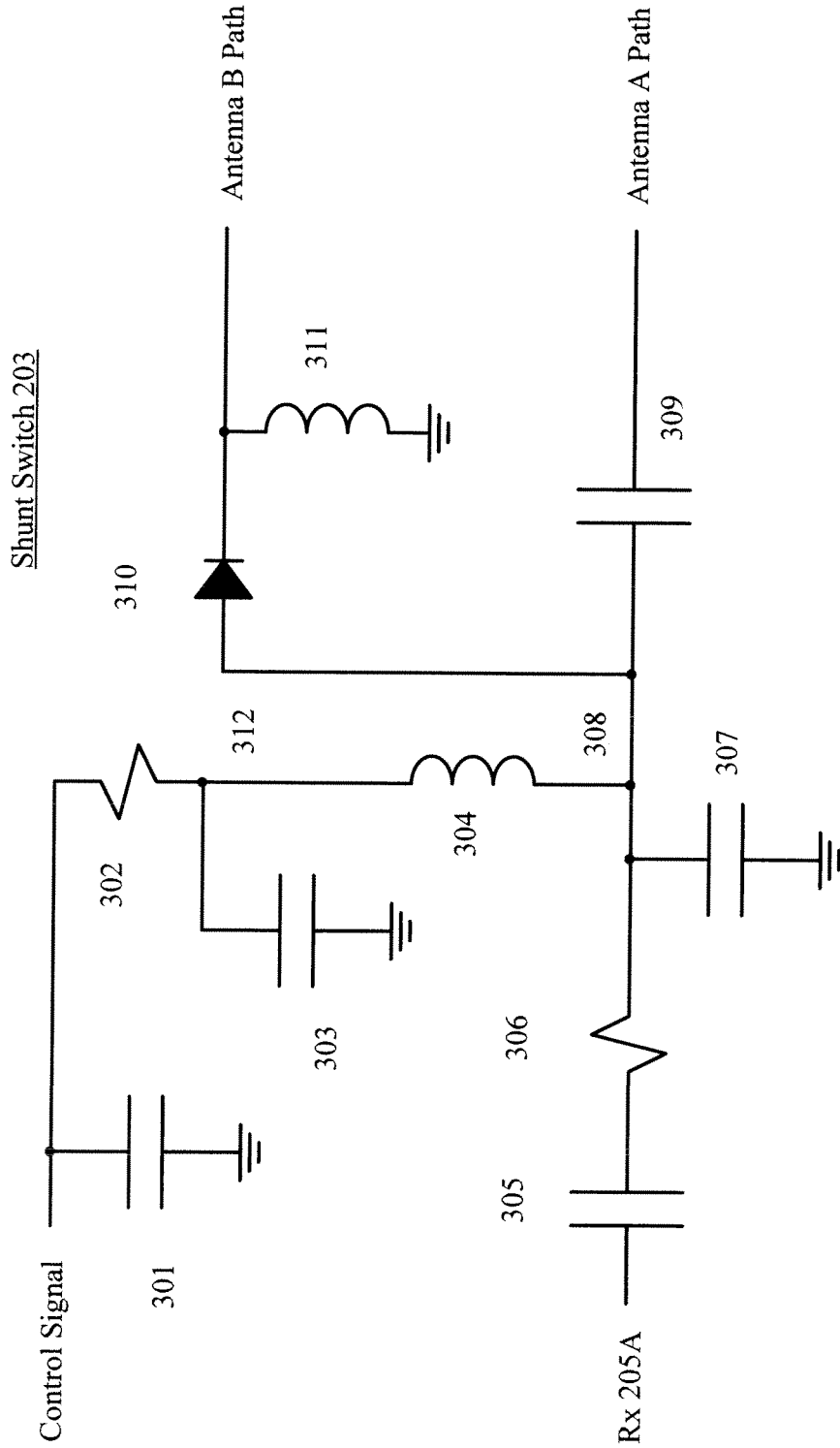

FIG. 3

MULTI-CHANNEL RX/TX CALIBRATION AND LOCAL OSCILLATOR MISMATCH MITIGATION

RELATED APPLICATIONS

[0001] This application is a divisional of U.S. patent application Ser. No. 12/942,659, entitled “Multi-Channel RX/TX Calibration And Local Oscillator Mismatch Mitigation” filed Nov. 9, 2010 which is a divisional of U.S. patent application Ser. No. 11/613,977, entitled “Multi-Channel RX/TX Calibration And Local Oscillator Mismatch Mitigation” filed Dec. 20, 2006 which claims priority of U.S. Provisional Patent Application 60/753,795, entitled “Multi-Channel RX/TX Calibration And LO Mismatch Mitigation” filed Dec. 22, 2005.

BACKGROUND OF THE INVENTION

[0002] 1. Field of the Invention

[0003] The present relates to multi-channel receiver/transmitter calibration and local oscillator mismatch mitigation.

[0004] 2. Description of the Related Art

[0005] Many wireless systems employ some form of multiple-radio signal combining to improve range and reliability in wireless systems. For example, maximal ratio combining can be employed to improve the signal to noise ratio (SNR) of signals simultaneously received from multiple antenna elements and receivers. The multiple receivers may be instantiated on a single chip or, alternatively, may be formed by duplicating analog radios. To provide optimized gains on transmit, the phase difference of the transmit waveforms can be controlled at the antenna elements. This control applies a known beam pattern on transmit based on a receive beam pattern to achieve similar gains for the wireless link on both receive and transmit.

[0006] Transmit beamforming schemes that use transmit phase calibration of the differences between the duplicated analog radios depend on a consistent phase relationship between the radios for the duration of the calibration period. Unfortunately, radio architectures that employ duplicated local oscillator generation circuits per radio can provide inconsistent phase states on initialization even when derived from a common lower frequency reference clock. The resulting uncertainty in local oscillator initialization states either requires a new transmit phase calibration per initialization or a one-time transmit phase calibration with a method for compensating for the local oscillator phase difference component of the transmit phase calibration per initialization.

[0007] For transmit beam forming some form of phase calibration of receive and transmit analog radios can be performed. A need arises for a method of calibrating the phase differences between transmit and receive analog components to achieve a controlled array pattern on transmit based on information derived on receipt. A further need arises for a method for transmit beam forming to compensate for local oscillator phase ambiguity between radios sharing a reference clock.

SUMMARY OF THE INVENTION

[0008] In accordance with one aspect of the invention, a method of optimizing transmit beam forming in a multiple radio wireless system is provided. In this method, a stimulus signal can be provided to an analog receive input of a device under test (DUT), the DUT including multiple radios. A

receive phase and amplitude can be measured at baseband using the stimulus signal for each radio. At this point, a receive weight can be determined using the receive phases and amplitudes. A receive weight conjugate can then be derived from the receive weight. Using this receive weight conjugate, a transmit weight can be computed. This transmit weight can be applied to transmit signals during the transmit beam forming using the multiple radios.

[0009] In one embodiment, the method of optimizing transmit beam forming can further include computing a calibration vector and deriving an associated calibration vector conjugate. In this embodiment, the product of the receive weight conjugate and the calibration vector conjugate generate the transmit weight.

[0010] In one embodiment, computing the calibration vector can include activating a shunt switch that connects receive components of the multiple radios. Computing the calibration vector and deriving the calibration vector conjugate can also include comparing a peak power during a range of phase shifts to a power as received by a unit providing the stimulus signal while the analog radios are transmitting. Computing the calibration vector and deriving the calibration vector conjugate can further include identifying a calibration phase that maximizes power. Alternatively, computing the calibration vector and deriving the calibration vector conjugate can further include identifying a calibration phase that minimizes power and add 180 degrees to the calibration phase.

[0011] A radio frequency (RF) system can advantageously include a shunt switch for optimizing transmit beam forming for multiple radios. Each radio can include an antenna, a T/R switch, an LNA, receive components, and transmit components. An exemplary RF system with first and second radios can include first and second antennas connected to first and second transmit/receive (T/R) switches. First and second low noise amplifiers (LNAs) can be connected to the first and second T/R switches, respectively. In the first radio, the first receive components and first transmit components can be connected to the first T/R switch. In the second radio, the second transmit components can be connected to the second T/R switch. Notably, the shunt switch can selectively connect the second receive components to either the first LNA or the second LNA.

[0012] An exemplary shunt switch can include a diode that acts as the switch. For example, the shunt switch can include a first capacitor connected between a first antenna path and a first node, a diode having an anode connected to the first node and a cathode connected to a second antenna path, a first inductor connected between the cathode of the diode and ground, a first resistor connected between a control signal terminal and a second node, a second inductor connected between the second node and the first node, a second capacitor connected between the second node and ground, and a third capacitor coupled between the first node and radio receiver components. In one embodiment usable during simulation, the shunt switch can further include a second resistor connected between the first node and the third capacitor, a fourth capacitor connected between the control signal terminal and ground, and a fifth capacitor connected between the first node and ground.

BRIEF DESCRIPTION OF THE FIGURES

[0013] FIG. 1A illustrates an RF system including two radios that can use commonly received signals to calibrate phase differences.

[0014] FIG. 1B illustrates a digital portion of the RF system shown in FIG. 1A.

[0015] FIG. 1C illustrates a graph indicating a calibration sweep result using the RF system shown in FIGS. 1A and 1B.

[0016] FIG. 2 illustrates a shunt switch that allows measuring of a receive phase difference between two radios.

[0017] FIG. 3 illustrates an exemplary embodiment of the shunt switch of FIG. 2.

DETAILED DESCRIPTION OF THE FIGURES

Multi-Channel Rx/Tx Calibration

[0018] FIG. 1A illustrates an exemplary RF system **100** including multiple radios, i.e. radio **100A** and radio **100B**. For transmit beam forming in conjunction with receive combining in RF system **100**, the relative phase difference measured at the antennas (e.g. connected to RF ports **102B**) on receive provides information on the appropriate phase difference at the antenna for transmit. However, the phase difference on receive is typically measured on digitized baseband receive signals as analyzed in digital portion **110**. Because radio **100A** and **100B** independently apply a phase shift on receive, especially where radios **100A** and **100B** are disposed in separate integrated circuits, a portion of the phase difference measured on the baseband digitized receive signal is due to the difference in phase shifts of the analog receivers r_1 and r_2 . Similarly, radios **100A** and **100B** provide an independent phase shift during transmit. Therefore, to achieve a controlled beam pattern on transmit based on information derived from the baseband receive waveforms, the transmit and receive phase differences between radios **100A** and **100B** must be compensated for to provide the desired phase difference at the RF port for transmit waveforms.

[0019] In accordance with one embodiment, the effects of receive and transmit phase shifts can be measured in radios **100A** and **100B** by providing a stimulus signal to the analog receive input of the device under test (DUT). The stimulus signal, which can be generated by external stimulus unit **101**, may be applied to the DUT via a splitter **103** at a manufacturing test station provided for this purpose. Note that splitter **103** is connected to external stimulus unit **101** via an RF port **102A**. Splitter **103** provides that stimulus signal to RF ports **102B**, which in turn then provide the stimulus signal to both radios **100A** and **100B**.

[0020] The receive phase and amplitude relationship is then measured at baseband in digital portion **110**. FIG. 1B illustrates an exemplary, simplified digital portion **110** of RF system **100** (FIG. 1A). In this embodiment, digital portion **110** can include means for providing functionality **111**. For example, functionality **111** includes determining channel estimation using digital signals S_1 and S_2 (e.g. $H(\text{vector})$ can be computed, which is the measured vector between digital signals S_1 and S_2). This measured vector represents the undesirable difference between the digital signals. Therefore, to ameliorate this undesirable difference, the conjugate of $H(\text{vector})$, i.e. $H(\text{vector})^*$, can be computed. Specifically, this $H(\text{vector})^*$ (also called $rx(\text{vector})$ or the Rx weight) can be used in the operation of the radio to mitigate the undesirable difference of $H(\text{vector})$.

[0021] To compute the transmit weight $tx(\text{vector})$, both the rx weight and a conjugate of the calibration vector can be used. Specifically, the product of the rx weight and the conjugate of the calibration vector provides the transmit vector. The calibration vector can be derived using the methods

described below for local oscillator (LO) mismatch mitigation. This transmit vector can then be applied to the two digital transmit signals P_1 and P_2 (wherein P_0 is the initial transmit signal that is divided into P_1 and P_2 for actual transmission using radios **100A** and **100B**). Note that the notation and associated computation for functionality **111** is well known to those skilled in the art and therefore is not described in detail herein.

[0022] Note that analog/digital interface **106** converts the processed analog signals generated by analog receivers r_1 and r_2 to provide digital signals S_1 and S_2 , respectively. Similarly, analog/digital interface **106** converts the processed digital signals P_1 and P_2 , which are generated by digital portion **110**, to analog signals that are provided to transmitters t_1 and t_2 , respectively.

[0023] Based on this information, a transmit phase and amplitude are derived for the transmit signals. In addition to the transmit phase and amplitude weighting derived from the receive signals using functionality **111** in digital portion **110**, a transmit calibration phase is applied to offset the phase of the transmit signals associated with radios **100A** and **100B**.

[0024] This calibration phase can advantageously compensate for the difference in receive to transmit phase shift between radios **100A** and **100B**. In one embodiment, the transmit calibration phase can be swept over a range of phase shifts while monitoring the power delivered in the direction of the stimulus signal. The calibration phase that maximizes the signal power delivered to the device providing the signal stimulus is stored in non-volatile memory **112** of digital portion **110** (see FIG. 1B) as the phase calibration to be used in operation.

[0025] An alternative method to finding the appropriate transmit calibration phase is to determine an appropriate transmit weighting based on the receive waveforms as before, but sweep the calibration phase applied to transmit to identify the calibration phase that minimizes the power delivered to external stimulus unit **101** providing the stimulus signal. FIG. 1C illustrates an exemplary calibration sweep **120** in a graph plotting RSSI **121** (as measured at the stimulus unit) and peak power **122**. This null-finding technique is advantageous in that the null, e.g. minimum power phase angle **123**, is sharper than the lobe, thereby yielding an easily detected and accurate measurement. Note that the appropriate transmit calibration phase to be used in this method is the minimum power phase angle plus 180 degrees.

[0026] Once a phase difference between receive channels is measured, the correction factor may be stored in, for example, non-volatile memory **112** (FIG. 1B). Transmit weights may be calculated by functionality **111** (in digital portion **110**) forming the product of the stored calibration data and the calculated receive weights.

[0027] For transmit beam forming in conjunction with receive combining in a multiple radio wireless system, the difference in phase of the waveforms arriving at each antenna on receive can advantageously provide information on the appropriate difference in phase to be applied at the antennas for transmit under the current wireless channel conditions.

[0028] In accordance with one aspect of the invention, to achieve a controlled beam pattern on transmit based on information derived from the baseband receive waveforms, the ratio between radios of the cumulative effects of receive and transmit phase shifts can be calibrated and applied as a phase offset between the radios on the transmit signal. After the appropriate transmit calibration phase angle is measured, this

value can be used as long as the phase relationships between chains on transmit and receive are preserved. In one embodiment, if the analog radios consistently power-up with similar phase shift differences between transmit and receive, then a one-time transmit phase calibration result may be stored in non-volatile memory on the device and used for power-up operations.

Multi-Channel Local Oscillator (LO) Mismatch Mitigation

[0029] In one embodiment, if the analog radios consistently power-up with similar phase shift differences between transmit and receive but with an additional phase shift due to local oscillator initialization, then a one-time transmit phase calibration scheme can be employed. However, in this case, with local oscillator initial phase ambiguity, some method of determining the relative phase between the radio local oscillators per initialization should be employed to compensate for this additional phase shift in the transmit phase calibration.

[0030] In accordance with one aspect of the invention, the local oscillator contribution per initialization can be determined by measuring the receive baseband phase difference of a stimulus signal with fixed phase difference at the receive antenna port and then repeating this measurement at each initialization. Notably, the method of determining the local oscillators' relative ambiguity can be accomplished away from a manufacturing test bed.

[0031] For example, FIG. 2 illustrates two radios **200A** and **200B** associated with antennas A and B, respectively, that can both receive external stimulus signals. In one embodiment, a stimulus signal can instead be generated locally by one of radios **200A** and **200B**. Radio **200B**, which is associated with antenna B, includes a transmitter/receiver (T/R) switch **201B** that can selectively connect antenna B to a receive path including a low noise amplifier (LNA) **202B** and receiver components **205B** or a transmit path including transmitter components **206B**.

[0032] Radio **200A**, which is associated with antenna A, includes a transmitter/receiver (T/R) switch **201A** that can selectively connect antenna A to a receive path including an LNA **202A** or a transmit path including transmitter components **206A**. In this embodiment, transceiver path **200A** further includes a shunt switch **203** that can selectively connect receiver components **205A** with either LNA **202A** or LNA **202B**.

[0033] Thus, in this configuration, shunt switch **203** can advantageously provide a common receive (e.g. stimulus) signal to both receive components **205A** and **205B**, thereby facilitating measuring a receive phase difference between radios. Specifically, shunt switch **203** can be "enabled", i.e. connecting receiver components **205A** to line **204** and LNA **202B**, and T/R switch **201A** can be "open", i.e. connecting antenna A of radio **200A** to neither the receive path, which includes LNA **202A**, nor the transmit path, which includes transmitter components **206A**. In one embodiment, the control signal for shunt switch **203** can be generated by calibration/initialization control **206**. Note that calibration/initialization control **206** could be implemented on an integrated circuit with radio **200A** or could be off-chip to both radios **200A** and **200B**. Further note that calibration/initialization control **206** could be implemented with, for example, and without limitation, state machines, software, registers, or hardware.

[0034] In this embodiment, to maximize receive sensitivity, shunt switch **203** can advantageously be placed downstream

of LNA **202A** (i.e. behind the first amplification stage) but upstream of receiver components **205A** (e.g. preceding the first mixing stage where the local oscillator relative phase shift will be added). After resolution of the local oscillators' relative ambiguity, shunt switch **203** can be "disabled", i.e. connecting receiver components **205A** to LNA **202A** (for standard operation), and T/R switch **201A** can be "closed", i.e. connecting antenna A to one of the receive path and the transmit path in radio **200A**.

[0035] In one embodiment, receive channel estimation circuitry **207** can advantageously perform this receive phase difference measurement during calibration (a one-time event typically performed by the manufacturer) and then later at initialization (typically performed by the user). Using these two measurements, the change in receive phase difference between radios **200A** and **200B** can be used to estimate the appropriate offset from the one-time calibration phase to the proper calibration phase given the current local oscillator initialized states. That is, the change in receive phase difference between radios **200A** and **200B** can be used to compensate for the local oscillators' relative ambiguity. This receive phase difference can be determined by digital portion **110** using functionality **111** (FIG. 1B).

[0036] Note that the amount of compensation can depend on the radio architecture. For example, with a super-heterodyne radio or transceiver that uses low-side injection (i.e. a carrier frequency less than the frequency of the local oscillator) for the mixers on receive and high-side injection (i.e. a carrier frequency greater than the frequency of the local oscillator) on transmit, the additional local oscillator phase shift component will be equal in the amount of phase shift but of opposite sign. Thus, if an X degree phase shift is measured on receive after initialization as compared to a Y degree phase shift measured on receive during the one-time calibration, then the additional phase shift on receive due to local oscillator initialization can be estimated as (X-Y) and the additional phase shift on transmit can be estimated as -(X-Y).

[0037] Further note that the compensation applied to the calibration phase can also depend on the method of signal processing applied to generate receive and transmit coefficients (e.g. the phi coefficients of the "e" terms provided to the mixers of the radios in RF system **100**, wherein $e_{j(\omega t + \phi)}$ is representative of a sine wave oscillation with a particular phase offset). For example, if the receive processing measures the relative phase between receive baseband signals and applies the conjugate of this phase on transmit, then the appropriate calibration phase compensation is the conjugate of twice the local oscillator contribution.

[0038] Notably, the above-described phase calibration technique can advantageously permit the resolution of the local oscillators' relative ambiguity without the necessity of receiving feedback channel state information from a cooperative wireless device. Therefore, the above-described phase calibration can be used in, for example, a legacy wireless LAN environment.

[0039] FIG. 3 illustrates an exemplary embodiment of shunt switch **203**. In this embodiment, a capacitor **309** is connected between the antenna A path and a node **308**. An anode of a diode **310** is connected to node **308**, whereas its cathode is connected to the antenna B path. An inductor **311** is connected between the cathode of diode **310** and ground. A resistor **302** and an inductor **304** are connected in series between a control signal terminal and node **308**. A capacitor **301** is connected between the control signal terminal and

ground. Another capacitor **303** is connected between ground and a node between resistor **302** and inductor **304**. A capacitor **305** and a resistor **306** are connected in series between receiver components **205** and node **308**. A capacitor **307** is connected between ground and a node between resistor **306** and node **308**.

[0040] In this configuration, if there is no forward biasing of diode **310**, then shunt switch **203** connects LNA **202A** (in the Antenna A path shown in FIG. 3) to receiver **205A** via capacitors **309/305**. When connection of Antenna A and Antenna B paths is desired, a logic **1** control signal can be provided to shunt switch **203**. This control signal can be filtered by capacitor **301**, resistor **302**, and capacitor **303**. Two RF chokes are provided by inductors **304** and **311**. This logic high control signal forward biases diode **310**, thereby connecting the Antenna B path to the Antenna A path at node **308**. Note that at this time, all components to the right of capacitor **309** are disconnected. In one embodiment, resistor **306** and capacitor **307** can be used during simulation to represent exemplary resistance and capacitance values of receiver **205A**.

[0041] A detailed description of one or more preferred embodiments of the invention is described above with accompanying figures that illustrate by way of example the principles of the invention. While the invention is described in connection with such embodiments, it should be understood that the invention is not limited to any embodiment. On the contrary, the scope of the invention is limited only by the appended claims and the invention encompasses numerous alternatives, modifications and equivalents. For the purpose of example, numerous specific details are set forth in the

following description in order to provide a thorough understanding of the present invention. The present invention may be practiced according to the claims without some or all of these specific details. For the purpose of clarity, technical material that is known in the technical fields related to the invention has not been described in detail so that the present invention is not unnecessarily obscured.

1. A shunt switch that facilitates measuring a receive phase difference between radios, the shunt switch comprising:

- a first capacitor connected between a first antenna path and a first node;
- a diode having an anode connected to the first node and a cathode connected to a second antenna path;
- a first inductor connected between the cathode of the diode and ground;
- a first resistor connected between a control signal terminal and a second node;
- a second inductor connected between the second node and the first node;
- a second capacitor connected between the second node and ground; and
- a third capacitor coupled between the first node and radio receiver components.

2. The shunt switch of claim **1**, further including:

- a second resistor connected between the first node and the third capacitor;
- a fourth capacitor connected between the control signal terminal and ground; and
- a fifth capacitor connected between the first node and ground.

* * * * *