



(11) (21) (C) **2,008,564**
(22) 1990/01/25
(43) 1990/07/25
(45) 2000/02/22

(72) Jaecklin, Felix P., CH

(73) Jaecklin, Felix P., CH

(51) Int.Cl.⁵ E02D 5/00, E02D 29/00

(30) 1989/01/25 (301,386) US

(54) **PAROI MURALE A OSSATURE GRAVITAIRE, ELEMENT DE CONSTRUCTION ET METHODE DE CONSTRUCTION CORRESPONDANTE**

(54) **WALL WITH GRAVITY SUPPORT STRUCTURE, BUILDING ELEMENT AND METHOD FOR CONSTRUCTION THEREOF**

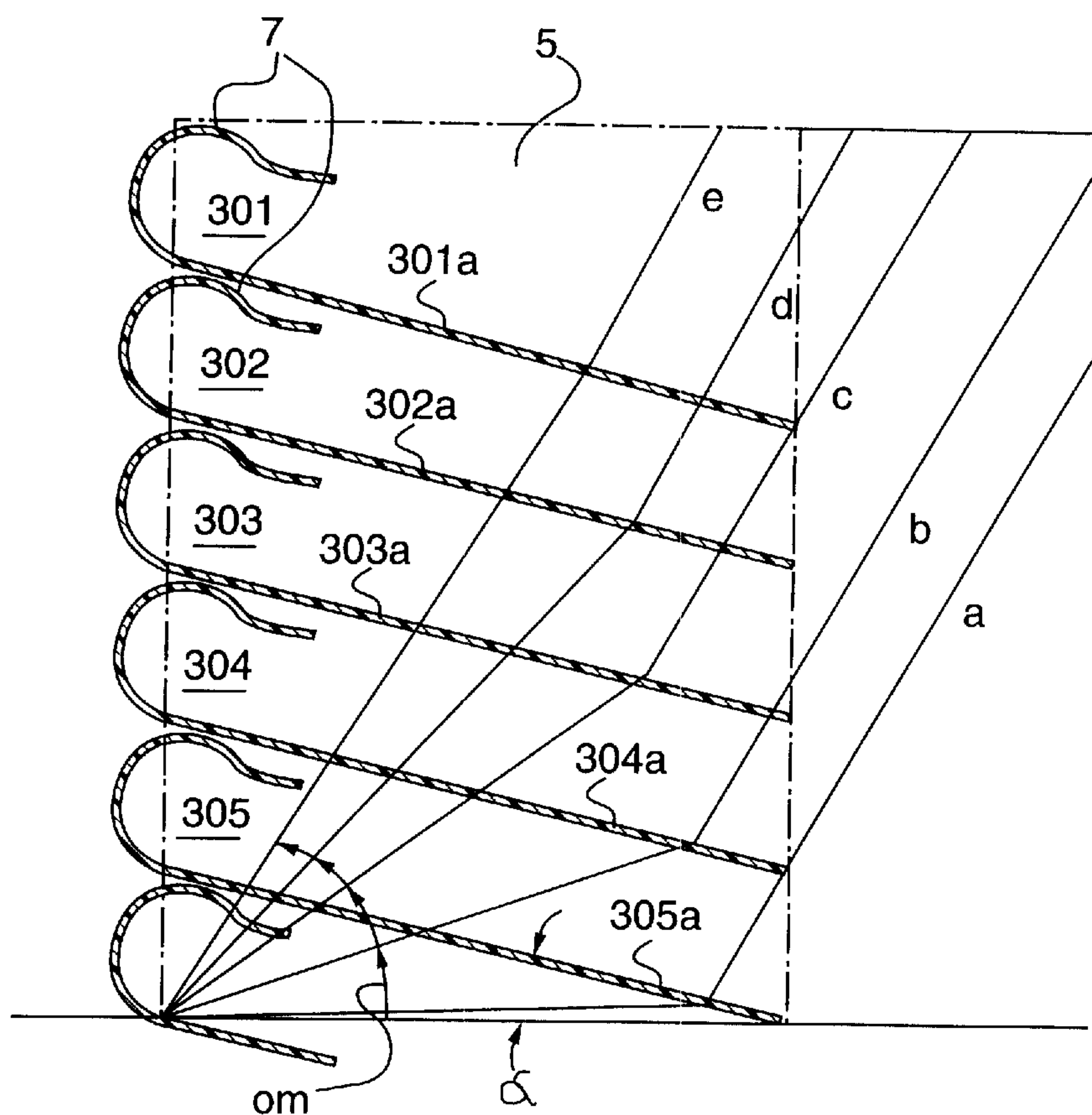

(57) The wall according to the present invention comprises a gravity support structure with a plurality of compartments or cells which are filled with bulk-material and surrounded or subdivided by flat and flexible envelope material, and on one front side or on both opposite front sides of this gravity support structure a fore-part, preferably in the form of a supporting grid structure, which is positively or frictionally connected with said gravity support structure. Such combined wall structure can be used for slope supporting as well as for noise absorbing or partition purposes, in the latter cases e.g. in the form of a stand-alone structure. An essential function of the fore-parts is the protection of the front portions of the envelope material holding the bulk material filling against violation and solar irradiation. The stability of the combined wall is greatly enhanced by anchoring the fore-parts to the gravity support structure by means of comparatively inexpensive tensile elements.



ABSTRACT

The wall according to the present invention comprises a gravity support structure with a plurality of compartments or cells which are filled with bulk-material and surrounded or subdivided by flat and flexible envelope material, and on one front side or on both opposite front sides of this gravity support structure a fore-part, preferably in the form of a supporting grid structure, which is positively or frictionally connected with said gravity support structure. Such combined wall structure can be used for slope supporting as well as for noise absorbing or partition purposes, in the latter cases e.g. in the form of a stand-alone structure. An essential function of the fore-parts is the protection of the front portions of the envelope material holding the bulk material filling against violation and solar irradiation. The stability of the combined wall is greatly enhanced by anchoring the fore-parts to the gravity support structure by means of comparatively inexpensive tensile elements.

WALL WITH GRAVITY SUPPORT STRUCTURE, BUILDING ELEMENT
AND METHOD FOR CONSTRUCTION THEREOF

Background of the Invention

Walls constructed as a gravity support structure with bulk material cells enveloped by flexible flat material such as foils or tissue of synthetic resins or plastic material are well known. They are in use particularly for supporting slopes. The front side of such a gravity support structure generally is formed by the front portions of the bulk material compartments or cells, i.e. by the front portions of the envelopes, which stand under the internal pressure of the bulk material filling and which form convex vaults. The bulk material cells superimposed on each other are in mutual positive or at least frictional, shear resistant connection. This results in an enhanced stability and support capability, especially against the horizontally acting pressure component of a slope located behind the gravity support structure. Due to their simple production and reduced expense there is an increasing demand for the application of such structures.

However, there are problems due to the envelope material being susceptible to piercing or tearing with the consequence of the bulk material running out and leaving the structure unstable.

Further, difficulties arise from the sensitiveness of the envelope material against solar irradiation. Providing an earth slope in contact with the front of the structure, which could shield the envelope against irradiation and facilitate planting, generally is difficult in view of poor connection between the smooth surface of the envelope material and the earth of the slope. This leads to separation due to natural settling of the earth and to undesired exposition of the envelope material.

Summary of the Invention

It is an object of the invention to create a wall construction comprising a gravity support structure with a plurality of cells which are filled with bulk material and surrounded or subdivided by flat and flexible envelope material, in which the front faces of said compartments and particularly the exposed portions of the envelope material are efficiently protected, whilst the advantages concerning stability and inexpensive production are preserved, particularly in the case of constructions with comparatively steep front faces.

This object is achieved by a wall construction comprising a gravity support structure with a plurality of cells which are filled with bulk material and surrounded or subdivided by flat and flexible envelope material, the wall being provided with at least one forepart which is positively or frictionally connected with said gravity support structure at least with regard to

horizontal forces acting between said forepart and said gravity support structure.

The structure offers essential advantages over the usually designed walls merely consisting of a supporting grid composed of frame-like elements. A major part of the structure volume and weight required to provide the tilting resistance or slope supporting capability can be realized by the gravity support structure and can be much less expensive. The foreparts make it possible to provide a front face structured by ribs and recesses so as to offer the best noise absorption and to form receptacles for earth to bear plants, particularly in the case of a grid support structure filled with earth as forepart.

Due to the gravity support structure taking over a great part of the stabilizing function the foreparts can be reduced considerably as to their dimensions, especially their wall thickness, and accordingly to the expenses.

For the purpose of anchoring the foreparts to the gravity support structure, preferably appropriate portions of the envelope material already present in the gravity support structure may be used. In the case of a stand-alone wall with two foreparts on opposite front sides of a centrally located gravity support structure, stability may be further enhanced substantially without additional expense by connecting the opposite foreparts or certain building elements thereof, which preferably are located on proximate levels, directly with each

other by means of tensile anchoring elements extending through the central gravity support structure.

Specific solutions to the aforesaid problems according to the present invention are defined by the features of Claims 1, 2, 3, 5, 8 and 11.

The invention will be further explained with reference to the enclosed drawings, wherein specific embodiments thereof are shown.

Brief Description of the Drawings

Figure 1 is a vertical cross-sectional view of an embodiment of a slope supporting wall.

Figure 2 is a vertical cross-sectional view of another alternate embodiment of a slope supporting wall.

Figure 3 is a vertical cross-sectional view of a wall with flexibly enveloped compartments within the adjacent bulk material.

Figure 4 is a vertical cross-sectional view of a specific wall with flexibly enveloped compartments of the present invention.

Figure 5 is a diagram relating driving forces, retaining forces and slope angle for the wall construction of Fig.4.

Figure 6 is a vertical cross-sectional view of a variation of a slope supporting wall according to the invention with specific anchoring structure.

Figure 7 is a vertical cross-sectional view of a specific wall according to the invention with a variation of a forepart anchoring structure.

Figure 8 is a vertical cross-sectional view of a wall variation according to the invention with additional anchoring structures.

Figure 9 is a vertical cross-sectional view of a wall comprising a specific anchoring structure with tensioned flexible anchoring members.

Figure 10 shows a variation of a detail in the anchoring structure of Figure 9.

Figure 11 shows a specific variation of a supporting or anchoring element in combination with flexible envelope or anchoring material.

Detailed Description of the Invention

The invention now will be explained in detail with reference to the examples schematically shown in the drawings. Fig. 1 illustrates in a vertical cross-section a wall 1 comprising a support structure 2 and a forepart 3. The support structure 2 includes a plurality of vertically arranged

compartments 41 to 45 filled with bulk material 5. As shown for the compartment 41 only, these compartments have a bottom face 4a, a front face 4b oriented towards the front 6 of the wall and an upper face 4c. The front, bottom and upper faces of compartments 41, 43 and 45 are defined by flexible envelope material 7 extending along said faces. Only the bottom and upper faces of compartments 42 and 44 are likewise defined by flexible envelope material, while the front faces have been left free. The forepart 3 comprises a plurality of support elements 41a to 45a arranged one above the other. They have also bottom, front and upper faces as evident from the illustration. The flexible envelope material defining the faces of compartments 41, 43 and 45 is elongated so as to cover the front faces of support elements 41a, 43a and 45a also.

In comparison with known walls, the front faces of which are formed substantially by front sections of flexible envelopes filled with bulk material, one of the advantages realized by the structure just described is the enhanced stability and rigidity of the front structure and, thereby, the enhanced supporting capability of the wall acting against the gravity pressure of earth and boulder material behind the wall.

A further major feature of the wall as just described has to be recognized in that there are differently arranged first and second support elements. The first ones are said elements 41a and 43a, the front faces of which are surrounded and covered by a section of flexible envelope material 7 extending out of the bulk

material behind the forepart. The second ones are said elements 42a and 44a, each of which is arranged beneath one of the said first support elements and in supporting connection therewith. The front faces of said second support elements are left free of flexible envelope material and shaped so as to project in direction towards the front 6 of the wall beyond the corresponding first support element arranged thereabove. Each of those second support elements forms a bearing surface 8 for a bulk material forefilling 9 covering at least partly the front face of said first support element arranged thereabove.

While supporting capability for many applications is not too much diminished by omitting the anchoring-by-envelopement effect for each second one of said support elements arranged one above the other, a substantial advantage is the covering of the front sections of the flexible envelope material by the said bulk material forefilling. This shields the flexible material, mostly consisting of plastics, from deterioration by ultraviolet irradiation. Furthermore, the slope surfaces formed by the forefilling offers sufficient basis for various plants as desired in view of landscape architecture.

A further important feature of the wall structure shown in Fig. 1 is based on the specific design of the support elements, such as elements 42a and 44a arranged therein. These elements comprise a front board section 40a extending in a direction along the front face of the wall. This board section forms an additional bearing surface 8a for bulk material, which together

with the basic bearing surface 8 explained above offers an enhanced root space for plants and secures the bulk material filling against erosion. Further there is a rear support section 40b extending in vertical direction so as to form bearing connections with the adjacent wall elements. An intermediate support section 40c also extending in vertical direction so as to form bearing connections with the adjacent wall elements. This double supporting connection by two support sections offset against each other in horizontal direction secures the elements positively against tilting and thus enhances the overall wall stability. It has to be understood that in view of heavy load conditions more than two such vertically extending support sections may be advisable.

In particular said rear and intermediate support sections are formed as rear or intermediate supporting board sections extending substantially in a direction along the front face of the wall. This contributes to enhanced stability of such sections against vertical pressure and allows a comparatively inexpensive production by way of profile casting in concrete due to the overall profile-like shape of said support elements.

Figure 2 illustrates an example of a different scheme for covering and securing the front sections 4b of the flexible envelope material 7 defining bearing compartments within a rear support structure 110. The front assembly of said rear support structure is formed by profile beams 101 to 107 superimposed one to the other. A forepart 111 comprising a plurality of mutually

superimposed auxiliary support elements 111a to 111c of box-like design, but lacking a bottom section and thus forming a vertical throughout channel filled with bulk material 5a, covers and supports the front sections of the flexible envelope material. Such forepart contributes substantially to the overall support capability of the wall.

Fig. 3 illustrates a bulk material wall with flexibly enveloped compartments 201 to 206 within the adjacent bulk material. Elongated anchoring sections 201a to 206a are embedded between mutually superimposed layers of bulk material substantially in horizontal planes. The stability conditions and supporting capability against earth pressure for such a structure is investigated by a method well known in the art, which method comprises calculating for each one of a representative plurality of slide-planes the sum or integral of the effective earth-pressure or slide-inducing forces in comparison with the sum or integral of the frictional holding forces within the bulk material, the frictional holding forces acting between the anchoring sections of the flexible envelope material and the adjacent bulk material and the holding tensile anchoring forces introduced through the intersections between the slide plane and said anchoring sections of the envelope material. In Fig. 3 slide planes a to e and their intersections A to E with anchoring material sections 206 to 202 have been schematically illustrated, furthermore the resultants of R_a to R_e of the holding frictional

forces and the anchoring forces Aa to Ae, all acting in said intersections.

As illustrated in Fig. 3, the sliding planes consist of two sections, namely firstly lower ones all starting in the common foot-line Lf and characterized by the slope angle α_m for each plane, and secondly upper ones starting in said intersections A to E respectively. The slope of all the last-mentioned sections of the slide-planes is the same, namely according to the inherent friction angle of the bulk material (not specifically designated in the illustration).

In contrast thereto, Fig. 4 shows a wall structure similar to Fig. 3 and comprising superimposed bulk material compartments 301 to 305 enveloped by flexible material 7, however, with a specifically inclined arrangement of the effective holding sections 301a to 305a thereof. Slide-planes a to e characterized by their slope angle α_m have been assumed in accordance with the known structure shown in Fig. 3. The same markings and designations apply as illustrated in Fig. 3, but they have been omitted for the sake of clarity.

Thorough investigations have shown that within a broad scope of applications favorable results are obtained by means of envelope-slope angles within a range from approximately 10 to 30 degrees in relation to the horizontal. Specifically for heavy load applications a slope angle within a range from approximately 18 to 24 degrees in relation to the horizontal has proved to be the best mode of operation.

The diagram of Fig. 5 illustrates firstly by, the curve T the dependency of the earth mass gravity driving force on the slope angle α of the different sliding faces within the block of earth, as is well known for any expert in the field. Furthermore, three curves of the earth retaining force being effective in the said different sliding faces characterized by the corresponding slope angle α . For each of those curves the bearing section of the geotextile layers extends under a different angle δ with regard to the horizontal, as depicted in Fig. 4 for the example of one specific value of δ . The steps of the curves R result from the increasing number of bearing geotextile sections becoming effective at certain angles α in succession. Any sliding angle for which the curve R falls below the curve T represents a critical condition. Obviously, increasing values of δ make it possible to obtain overall safety with the same amount of geotextile.

Essentially in the wall construction of Fig. 6 is firstly that the forepart 400 besides concrete support elements 401 and 402 formed as longitudinal profile beams extending horizontally parallel to the wall plane comprises a further support element 403 formed as a compartment filled with bulk material 405, which may be of consistence and stability different from the main bulk material 404 located behind the forepart 400. By using appropriate bulk material 405, i.e. even such as fresh concrete which hardens after filling-in, such support element can contribute substantially to the stability of the forepart and the wall as a whole.

Support element 403 is defined, i.e. in the embodiment shown surrounded, by flexible envelope material 406, which may also be of specifically appropriate nature, e.g. of permeable or broken structure so as to facilitate roots of plants to grow in. More than one such specific support element may be provided. A second essential feature in the wall of Fig.6 is a specific anchoring structure for supporting elements 401 and 402 comprising further or additional flexible envelope material 407 extending into the bulk material 404. In the anchoring structure shown it is further important that the the further or additional flexible envelope material 407 extends in a one-piece configuration alternately around one support element 401 or 402, then with a comparatively long flat section into bulk material 404, further around a specific anchoring element 408, e.g. in the form of a longitudinal profile beam extending in parallel or under an acute angle to the wall plane, further back toward the forepart 400 and here again around a further support element 401 or 402. The anchoring stability thus obtained with small additional expenses is a greatly enhanced one.

The embodiment shown in Fig.7 shows also a support element 403 as part of the forepart 400 in the form of a flexibly enveloped and bulk-material filled compartment. Here it is further shown that such support element 403 also may contribute to the anchoring stability by means of flexible anchoring material 407 surrounding the said support element

and extending into the bulk material 404, where it is fixed by friction or by means of anchoring elements (not shown).

The variation of Fig.8 shows as a further advantageous measure according to the present invention an anchoring element 409 formed again as a flexibly enveloped and bulk-material filled compartment embedded in the main bulk material 404 located behind the forepart 400 e.g. in addition to a solid anchoring element 408. This measure also may beneficially contribute to minimizing the expenses of the whole structure. In the example shown, the flexible anchoring envelope material 407 is frictionally connected to the forepart, which in certain cases may be sufficient. Again, it is to be understood that a greater number of flexibly enveloped anchoring compartments may be provided.

The sloped construction of the forepart as shown in the last embodiments also contributes substantially to the wall stability against tilting under the earth pressure from behind the wall.

The embodiment of Fig.9 shows a wall comprising a forepart 400 including support elements 403 in the form of profile beams, a support structure 413 including compartments 415 filled with bulk material and defined partially by flexible envelope or anchoring material 417, and an anchoring structure 410 including anchoring elements 421. The flexible envelope or anchoring material 417 extends in a one-piece configuration

alternately around said support and anchoring elements as well as through bulk material 411 in said compartments. In the state of construction shown, the uppermost compartment 421 is partially completed, i.e. including its support element 423 and bulk material 404 partially filled in, but the upper layer of envelope or anchoring material 417 not yet spread over the compartment, but rather still laying on top thereof as a roll 425. Anchoring element 421 has two horizontally spaced projections 431, therebetween being an empty space 427 with an opening oriented upwards. This opening is covered by a section of material 417, which bears the corresponding portion of bulk material 404. Thus material 417 in the range of said opening is tensioned by the gravity of the bulk material located on the upper side thereof. This gravity force is shown by arrow 429, which causes bending of material 417 into space 427. This arrangement causes tensioning of material 417 in the range between support and anchoring elements, which has been shown by arrow 429. It has to be understood that the uppermost layer of material 417 in this state is supported by the bulk material from below, but pressed on its upper side merely by the comparatively small gravity forces of the layer of bulk material 404 so that tensioning will not be impeded. The beneficial effect of said tensioning is an exact alignment of support and anchoring elements during construction of the wall as well as an enhancement of the anchoring forces.

As illustrated in Fig.10, in such structure said projections 431 forming an empty space 427 therebetween may be established

with great advantage as to expenses by two or more separate anchoring elements 433 arranged with mutual distance. Furthermore, this variation shows the formation of such anchoring elements as compartments filled with special bulk material 435 and surrounded by appropriate flexible envelope material 437, which also contributes to minimization of expenses. Particularly, such special bulk material may be one which hardens or cures after filling in so as to form an at least partially solid anchoring body. The said special envelope material may then be a very cheap one. It has to be understood that support elements used in a forepart or in other parts of the wall may also be formed as such bulk-material filled, particularly hardening material-filled compartments.

Fig. 11 shows a variation of support or anchoring element 439 having an elongated opening or slot 441, through which flexible envelope or anchoring material 417 extends. This allows for enhanced force transmission illustrated by tensioning arrows 429.

WHAT IS CLAIMED IS:

1. A wall comprising a support structure and a forepart, said support structure including a plurality of compartments filled with bulk material and arranged one above the other, said compartments being at least partially defined by flexible envelope material, said forepart comprising a plurality of support elements, at least part of said flexible envelope material extending around at least a part of at least one of said support elements so as to form an anchoring and back-up tensile connection between said support structure and said forepart.

2. A wall comprising a support structure and a forepart, said support structure including a plurality of compartments filled with bulk material and arranged one above the other, said compartments being at least partially defined by flexible envelope material, said forepart comprising a plurality of support elements, at least one of said compartments filled with bulk material extending around at least a part of at least one of said support elements so as to form an anchoring and backup tensile connection between said support structure and said forepart.

3. A wall according to claim 1 wherein said compartments have a bottom face, a front face oriented towards the front of the wall and an upper face, the front face and at least one of both the said bottom and upper faces of each of the compartments being defined by said flexible envelope material extending along

said faces of the compartments, and said support elements are arranged one above the other and have a bottom face, a front face and an upper face, the flexible envelope material extending along the bottom or upper face of at least one of said compartments being dimensioned so as to cover and surround the front face of at least one of said support elements.

4. A wall according to claim 2 wherein said compartments have a bottom face, a front face oriented towards the front of the wall and an upper face, the front face and at least one of both the said bottom and upper faces of each of the compartments being defined by said flexible envelope material extending along said faces of the compartments, and said support elements are arranged one above the other and have a bottom face, a front face and an upper face, the flexible envelope material extending along the bottom or upper face of at least one of said compartments being dimensioned so as to cover and surround the front face of at least one of said support elements.

5. A wall according to claim 3 or 4, in which first and second support elements are provided, the front face of at least one of said first support elements being covered by a section of said flexible envelope material which extends out of the bulk material behind said forepart so as to surround said at least one first support element, at least one of said second support elements being arranged beneath at least one of said first support elements and in supporting connection therewith, the front face of said second support element being left free of said

flexible envelope material and being shaped so as to project in direction towards the front of the wall beyond said first support element and so as to form a bearing surface for a bulk material forefilling covering at least partly the front face of said first support element.

6. A wall according to claim 3 or 4 comprising a front cover structure arranged in front of said forepart so as to shield at least the sections of said flexible envelope material which extend along the front faces of said support elements.

7. A wall according to claim 1 wherein each of said support element comprises a front board section extending at least partly in a direction along a front face of the wall and forming at least one bearing surface for bulk material, at least one rear support section extending in vertical direction so as to form bearing connections with at least one vertically adjacent wall element and at least one intermediate support section also extending in vertical direction so as to form bearing connections with said at least one adjacent wall element.

8. A wall according to claim 2 wherein each of said support element comprises a front board section extending at least partly in a direction along a front face of the wall and forming at least one bearing surface for bulk material, at least one rear support section extending in vertical direction so as to form bearing connections with at least one vertically adjacent wall element and at least one intermediate support section also



extending in vertical direction so as to form bearing connections with said at least one adjacent wall element.

9. A wall according to claim 7 or 8 in which at least one of said rear and intermediate support sections is formed as rear or intermediate supporting board sections, respectively.

10. A wall according to claim 7 or 8 in which at least one of said rear or intermediate supporting board sections at least partly extends substantially in a direction along the front face of the wall.

11. A wall comprising a support structure, said support structure including a plurality of vertically arranged compartments filled with bulk material, said compartments having a bottom face, a front face oriented towards the front of the wall and an upper face, at least one of both the said bottom and upper faces of each of the compartments being defined by flexible envelope material extending along said faces of the compartments, in which said flexible envelope material extending along at least said bottom and/or upper face of at least one of said compartments is arranged within the adjacent bulk material substantially in an inclined direction descending from the front of the wall towards the backward region of the bulk material.

12. A wall according to claim 11 in which the flexible envelope material extending along the bottom and/or upper face of at least one of said compartments is substantially arranged

so as to form a slope descending in a direction from the front of the wall towards the rear of the bulk material filling under an angle within a range from approximately 10 to 30 degrees in relation to the horizontal.

13. A wall according to claim 11 in which the flexible envelope material extending along the bottom and/or upper face of at least one of said compartments is substantially arranged so as to form a slope descending in a direction from the front of the wall towards the rear of the bulk material filling under an angle within a range from approximately 18 to 24 degrees in relation to the horizontal.

14. A wall comprising a support structure including a plurality of vertically arranged compartments filled with bulk material and at least partially defined by flexible envelope material, in which at least part of said envelope material extends into bulk material located behind said wall and around at least one anchoring element embedded in said bulk material located behind the wall.

15. A wall according to claim 14, comprising a forepart including a plurality of vertically arranged support elements, in which at least one of said support elements is connected to at least one layer of flexible anchoring material extending into bulk material located behind said forepart and around at least one anchoring element embedded in said bulk material.

16. A wall according to claim 15 in which said at least one anchoring element is formed as a longitudinal body extending parallel or under an acute angle in relation to the plane of the wall within said bulk material.

17. A wall according to claim 15 in which said at least one anchoring element is formed as a compartment filled with bulk material and defined by flexible envelope material.

18. A wall according to claim 16 in which said at least one anchoring element is formed as a compartment filled with bulk material and defined by flexible envelope material.

19. A wall according to claim 14 in which said at least one anchoring element comprises at least two projections extending upwards, between said projections there being a space having an opening oriented upwards and being at least partially empty or filled with compressible material, there being at least one layer of flexible envelope or anchoring material extending over said opening and being in contact with said projections, on the upper side of said at least one layer of flexible envelope or anchoring material there being gravity material so as to tension said layer by bending it into said space.

20. A wall according to claim 15 in which said at least one anchoring element comprises at least two projections extending upwards, between said projections there being a space having an opening oriented upwards and being at least partially empty or

filled with compressible material, there being at least one layer of flexible envelope or anchoring material extending over said opening and being in contact with said projections, on the upper side of said at least one layer of flexible envelope or anchoring material there being gravity material so as to tension said layer by bending it into said space.

21. A wall according to claim 14 in which there are at least two anchoring elements arranged in spaced relationship and each comprising at least one projection extending upwards, between the projections of said anchoring elements there being a space having an opening oriented towards and being at least partially empty or filled with compressible material, there being at least one layer of flexible envelope or anchoring material extending over said opening and being in contact with said projections, on the upper side of said at least one layer of flexible envelope or anchoring material there being gravity material so as to tension said layer by bending it into said space.

22. A wall according to claim 15 in which there are at least two anchoring elements arranged in spaced relationship and each comprising at least one projection extending upwards, between the projections of said anchoring elements there being a space having an opening oriented towards and being at least partially empty or filled with compressible material, there being at least one layer of flexible envelope or anchoring material extending over said opening and being in contact with said

projections, on the upper side of said at least one layer of flexible envelope or anchoring material there being gravity material so as to tension said layer by bending it into said space.

23. A wall according to claim 1, 2, 3, 4, 7, 8, 11, 12, 13, 14, 15, 16, 17, 18, 19, 20, 21 or 22 comprising at least one support or anchoring element formed as a compartment filled with bulk material and defined by flexible envelope material wherein said compartment is filled at least partially by bulk material capable of hardening or curing to an at least partially solid body after filling in.

24. A wall according to claim 1, 2, 3, 4, 7, 8, 11, 12, 13, 14, 15, 16, 17, 18, 19, 20, 21 or 22 comprising at least one support or anchoring element formed as a compartment filled with bulk material and defined by flexible envelope material wherein said compartment is filled at least partially by bulk material capable of hardening or curing to an at least partially solid body after filling in and said support or anchoring element comprises at least one elongated opening through which flexible envelope or anchoring material extends.

25. A wall comprising at least one support or anchoring element formed as a compartment filled with bulk material and defined by flexible envelope material, in which said compartment is filled at least partially by bulk material capable of

hardening or curing to an at least partially solid body after filling in.

26. A wall according to claim 25 wherein said support of anchoring element comprises at least one elongated opening through which flexible envelope material extends.

BARRIGAR & MOSS
81 Metcalfe St., 7th Floor
Ottawa, Ontario
K1P 6K7

Agents for the Applicant

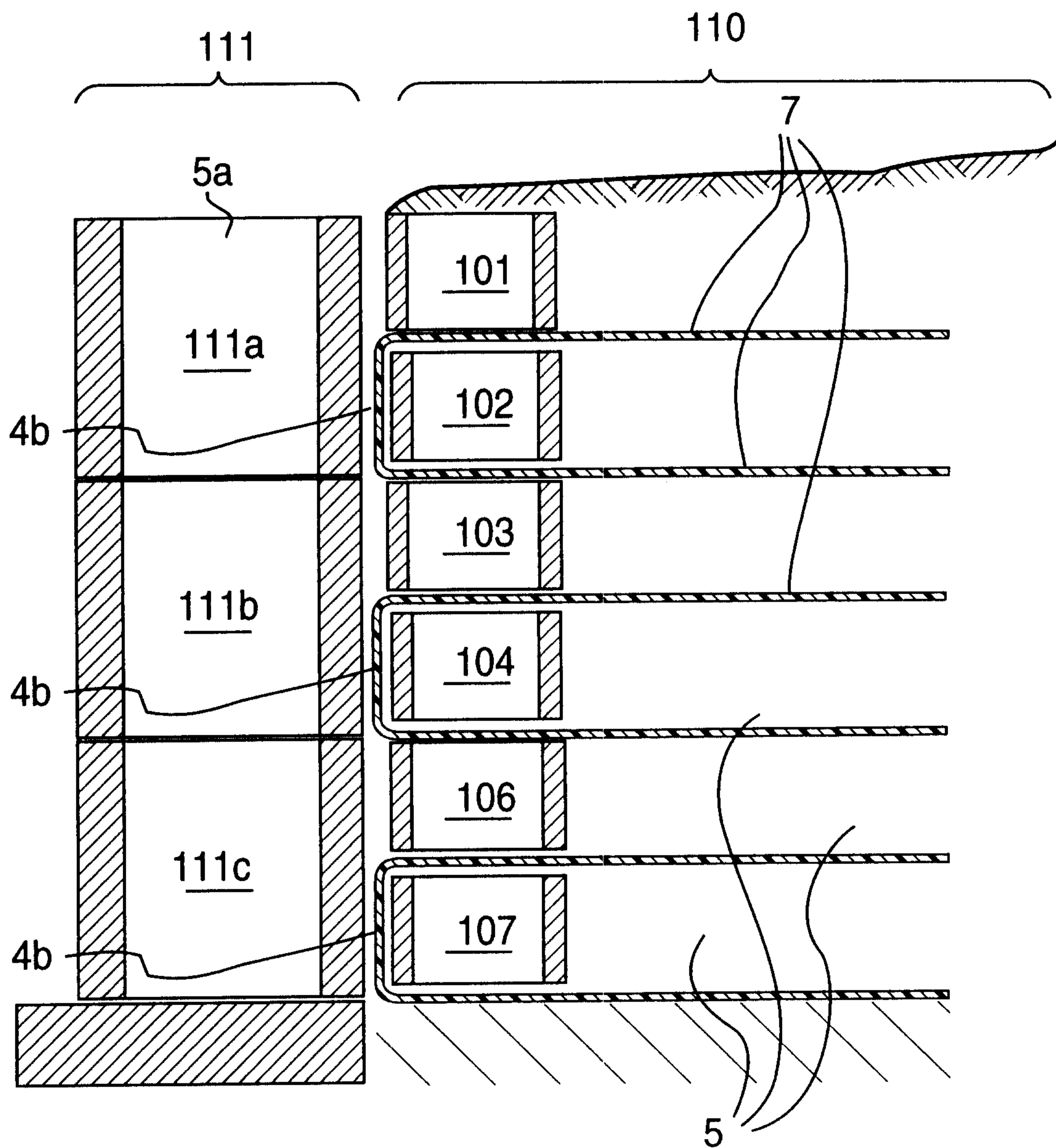

FIG.2

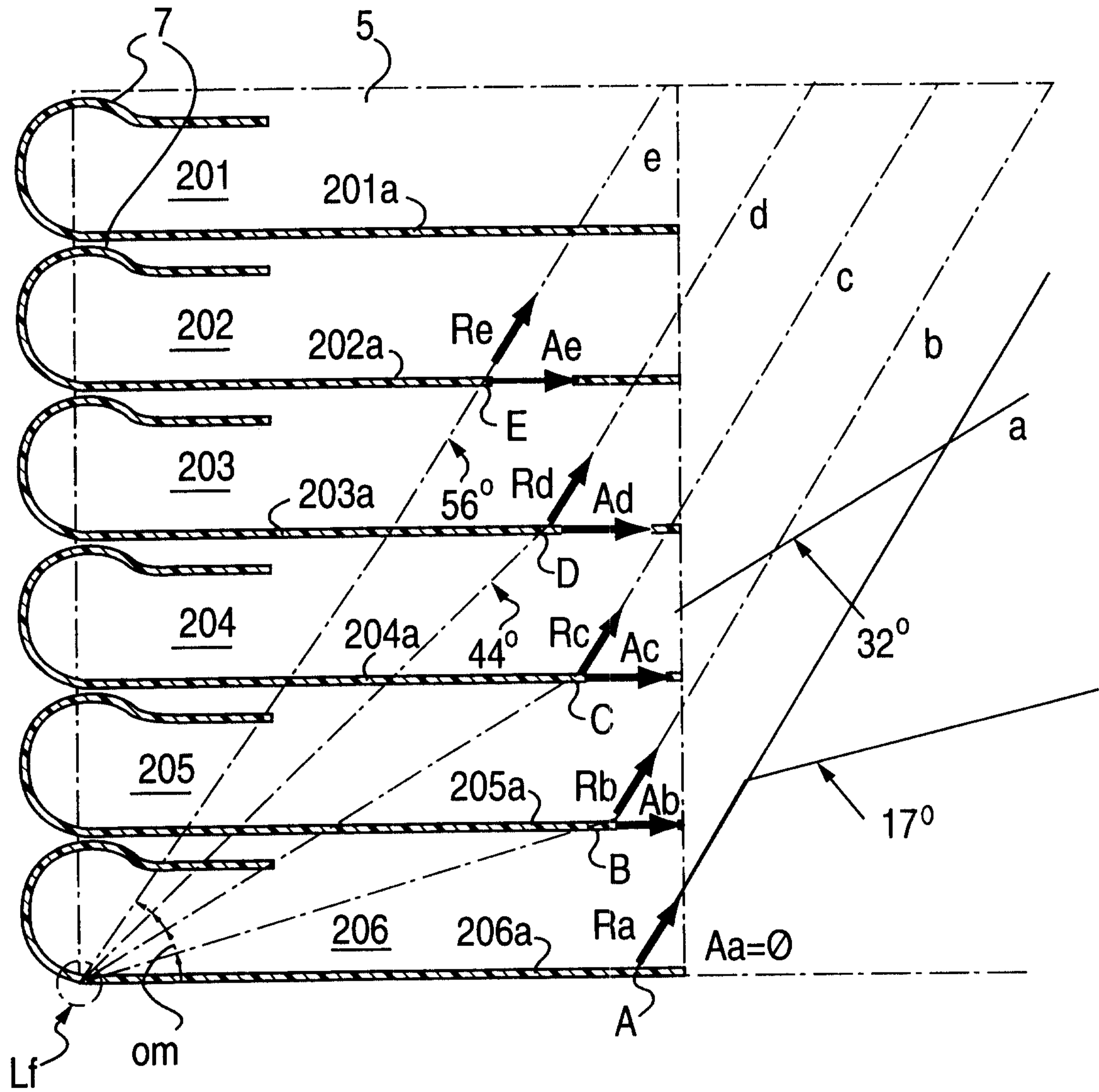

FIG.3

B

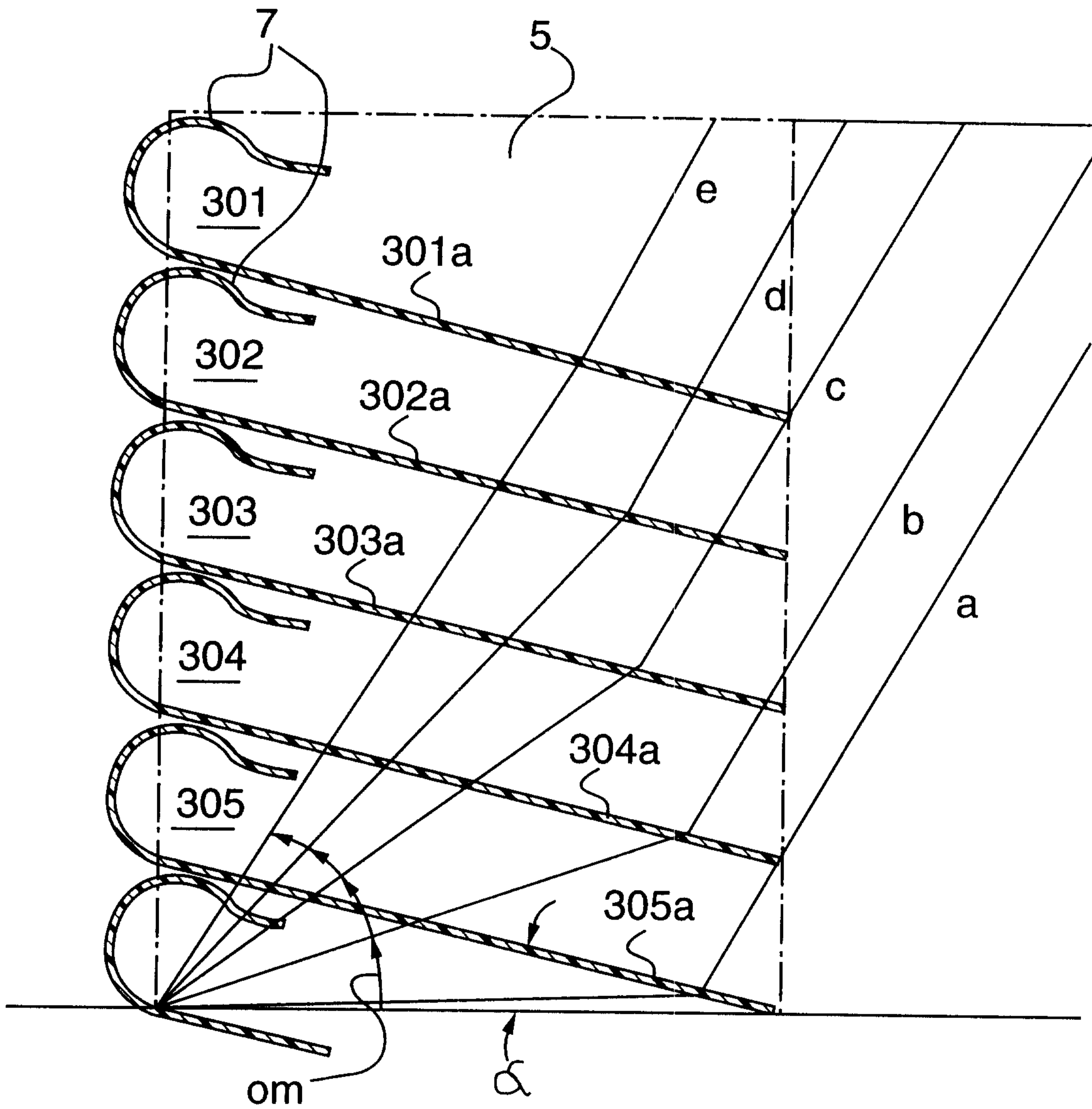

FIG.4

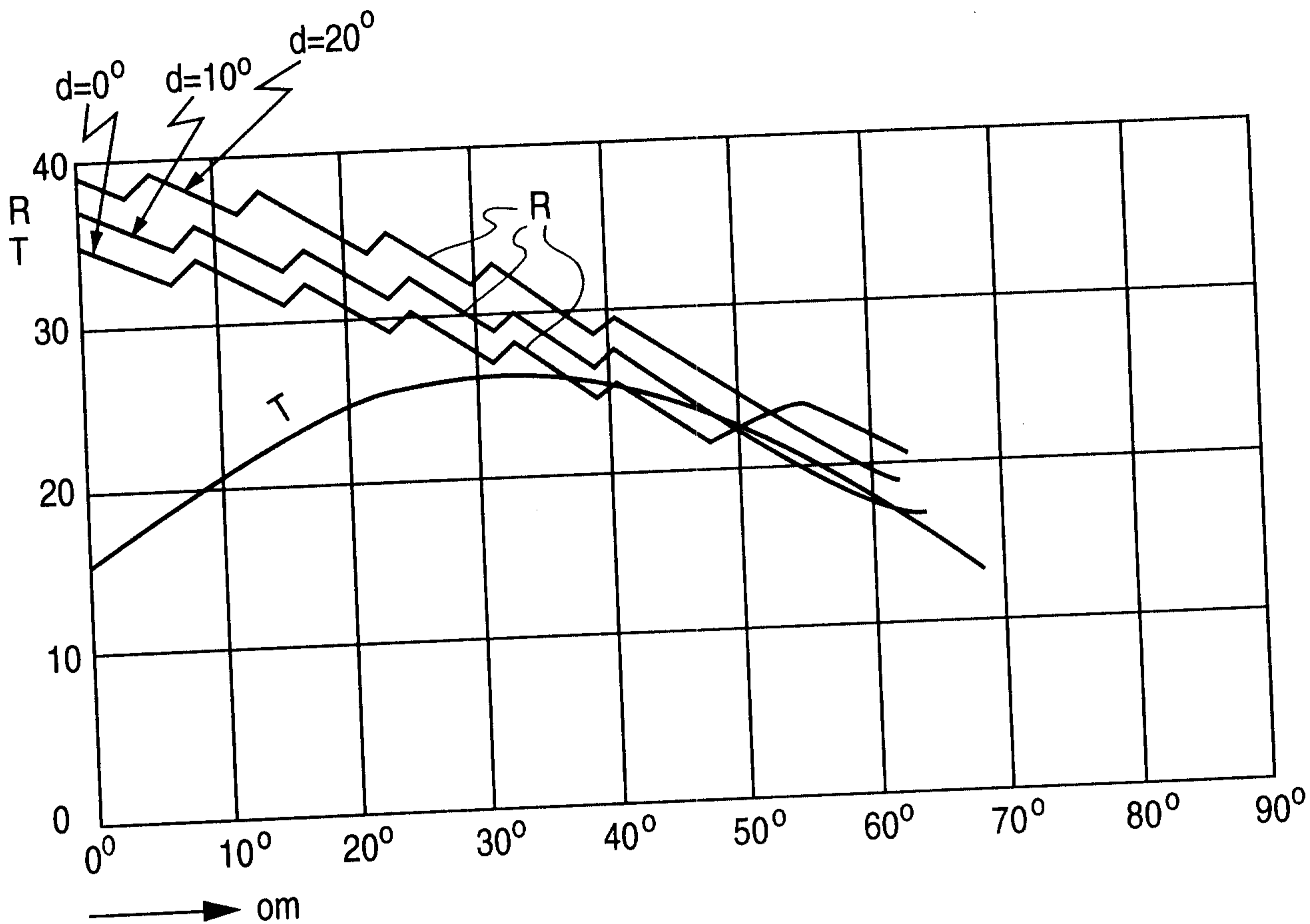

FIG.5

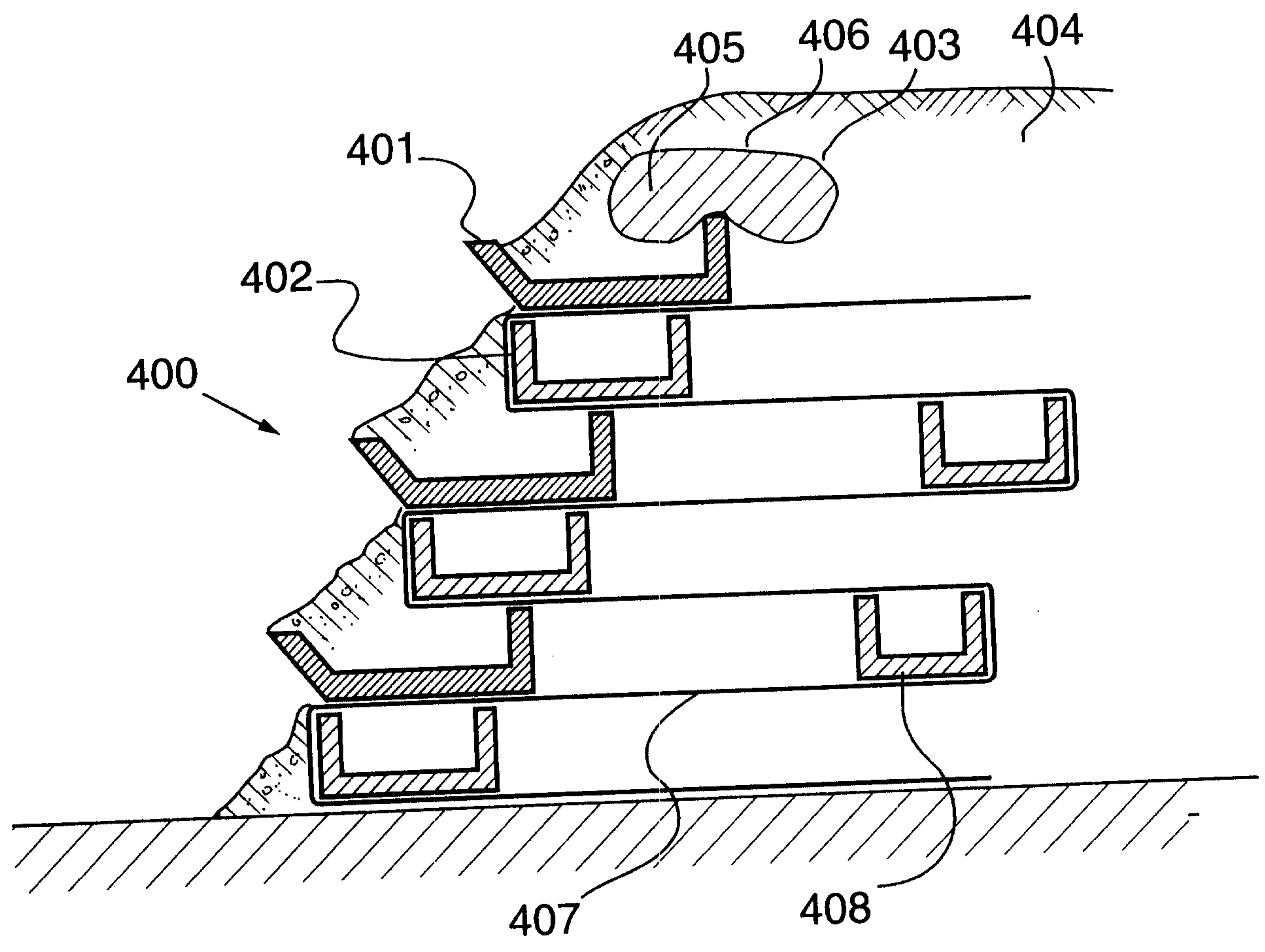
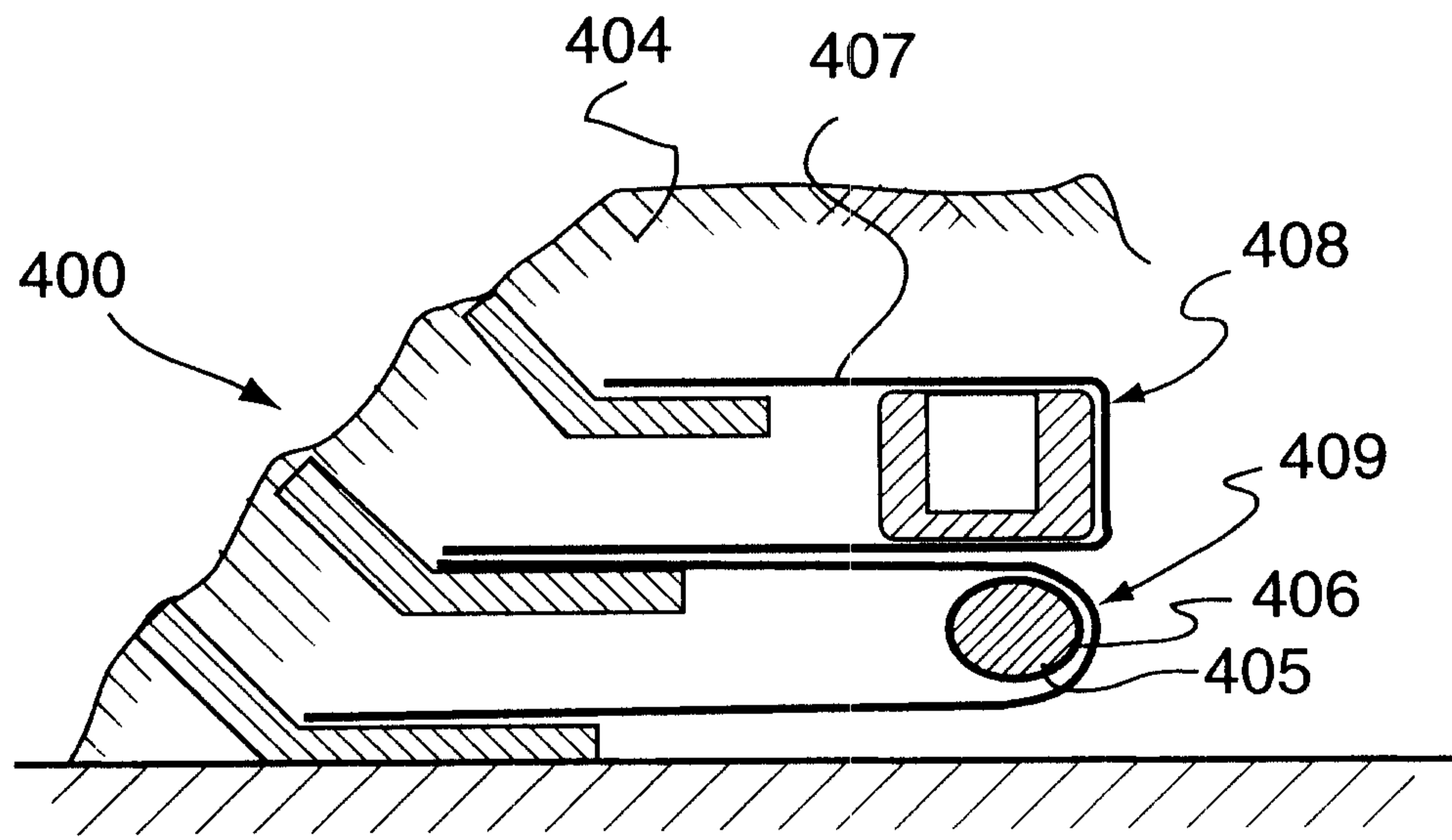
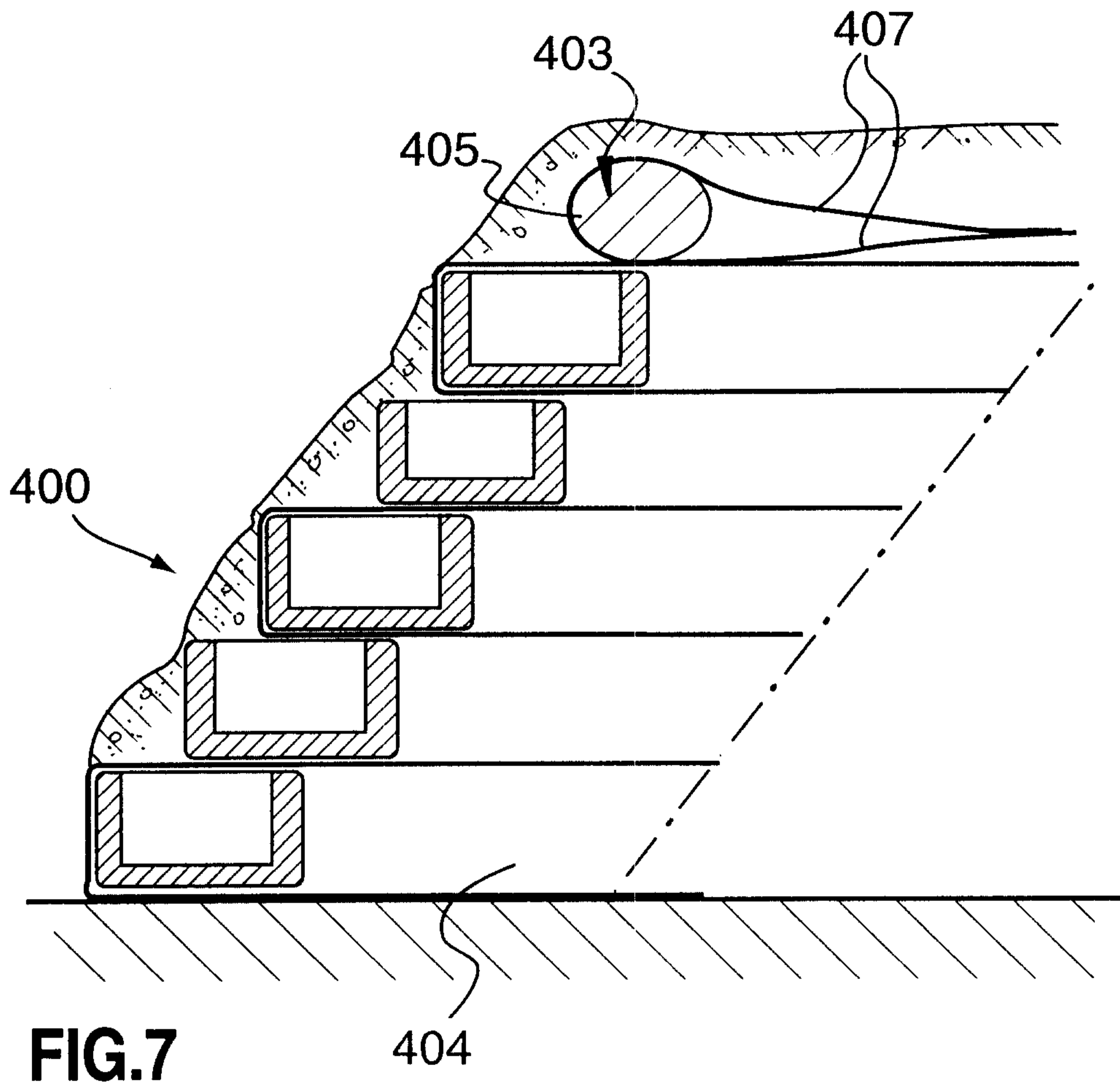

FIG.6





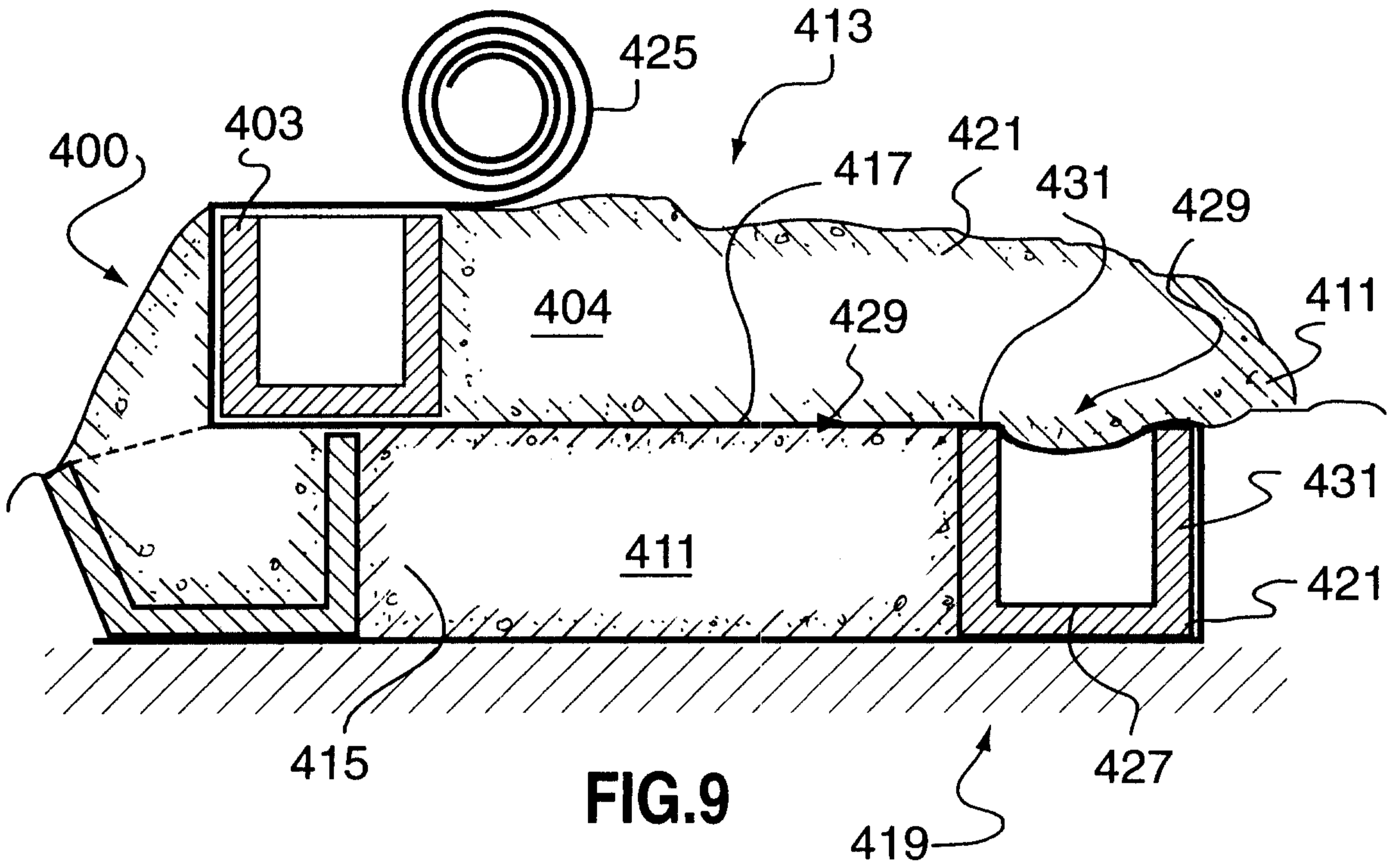

FIG. 9

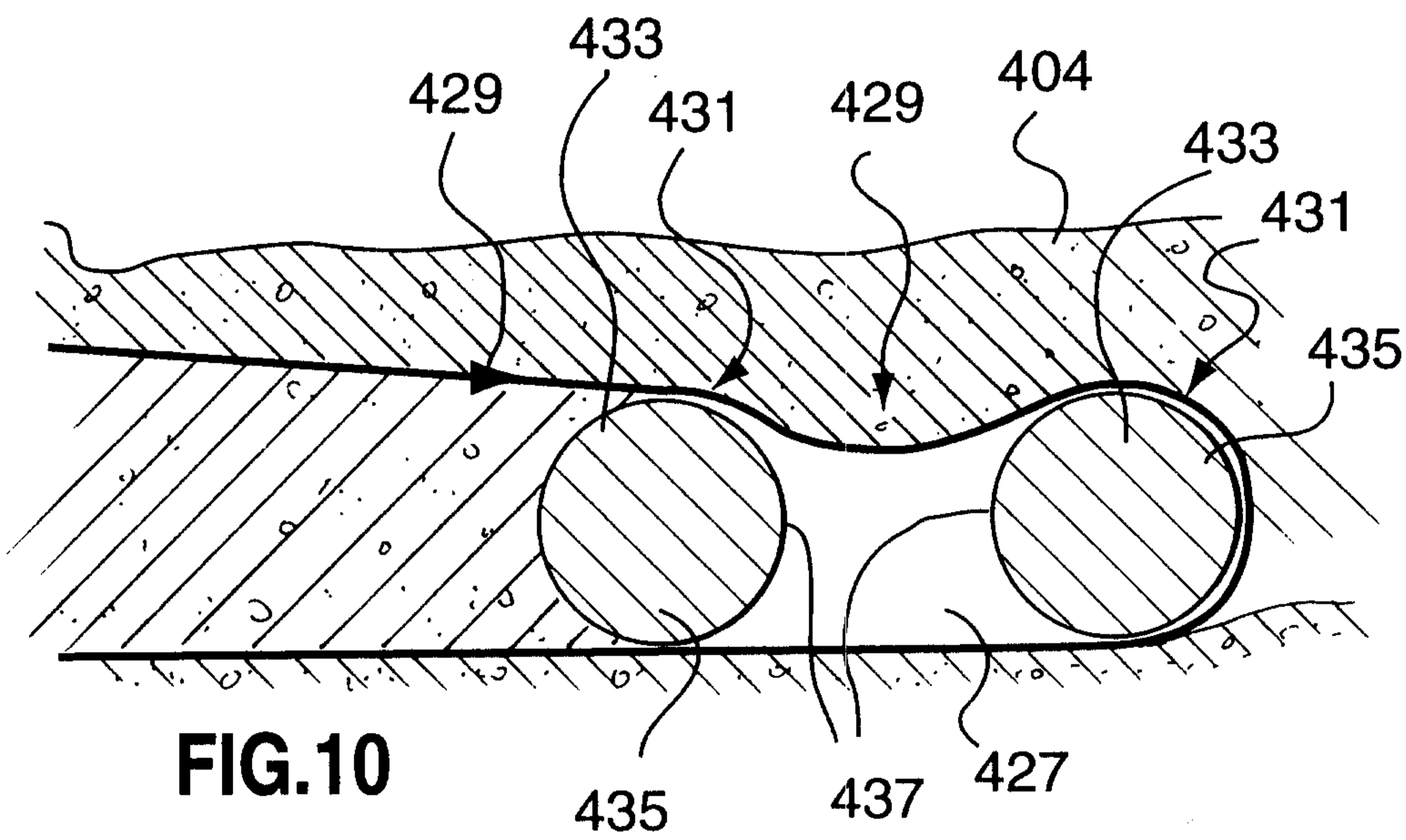

FIG. 10

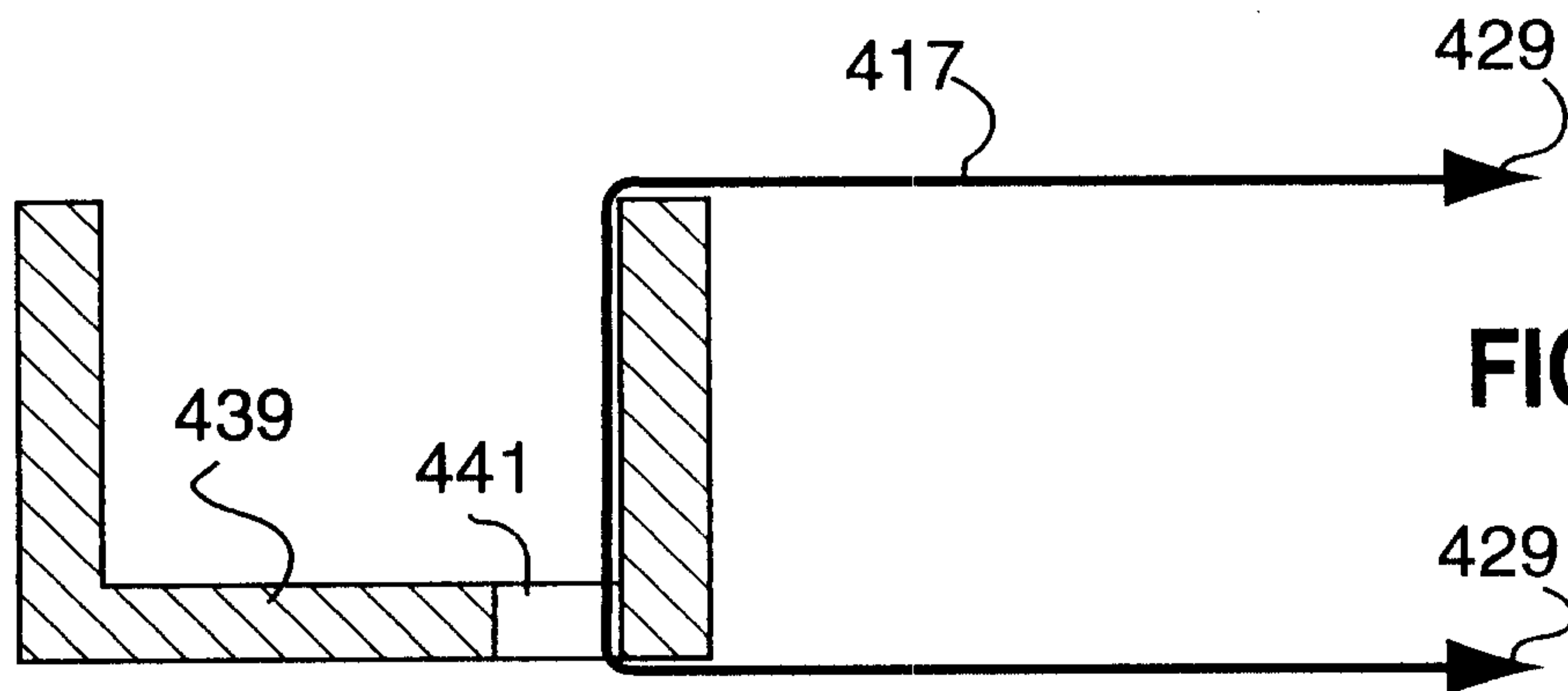

FIG. 11

B