



US 20130327576A1

(19) **United States**

(12) **Patent Application Publication**  
**Gien**

(10) **Pub. No.: US 2013/0327576 A1**

(43) **Pub. Date: Dec. 12, 2013**

(54) **PERCUSSIVE DRILL BIT PROVIDED WITH AN IMPROVED CHUCK ASSEMBLY**

(52) **U.S. Cl.**

CPC ..... *E21B 10/36* (2013.01)

USPC ..... *175/414*

(71) Applicant: **Bernard Lionel Gien**, Edenvale (ZA)

(72) Inventor: **Bernard Lionel Gien**, Edenvale (ZA)

(21) Appl. No.: **13/854,250**

(22) Filed: **Apr. 1, 2013**

**Related U.S. Application Data**

(63) Continuation of application No. 12/776,589, filed on May 10, 2010, now abandoned.

**Publication Classification**

(51) **Int. Cl.**  
*E21B 10/36* (2006.01)

(57) **ABSTRACT**

The invention provides a drill bit for a down-the-hole drill hammer. The bit has a head at its forward end with a shank extending from the head. The shank is screw threaded along its length. A reciprocating chuck is provided as a sleeve with internal screw threads corresponding to those of the shank. The shank is releasably secured in the chuck with the rear end of the shank providing a striking face. An arrangement of external splines on the chuck, and a retaining shoulder at its rear end, provide for the required guided movement of the chuck within a drill hammer wear sleeve. The bit is simple to machine with screw threads replacing the usual splines and other structural features ordinarily required on this component. These features are instead provided on the chuck and in the wear sleeve.

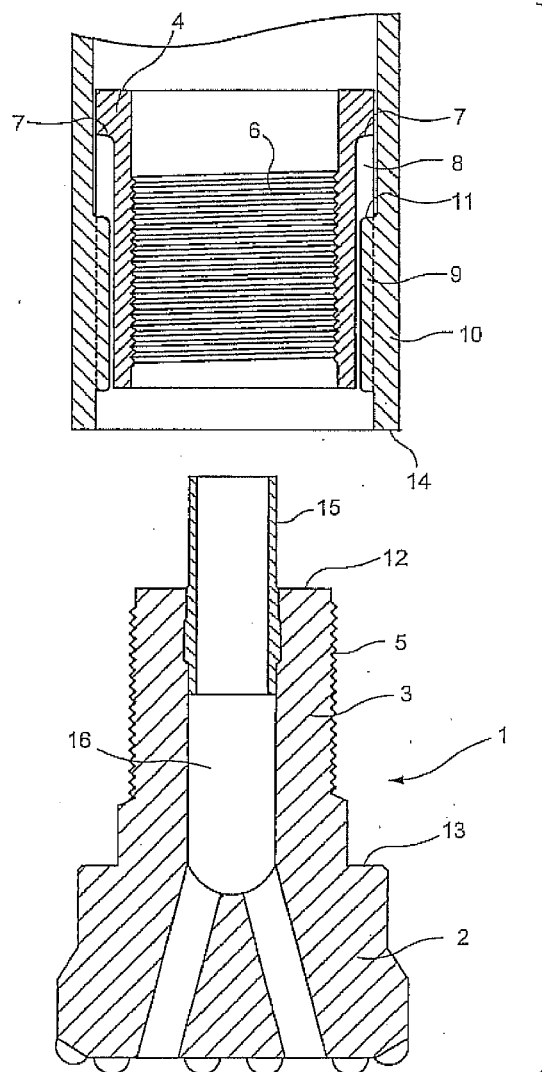

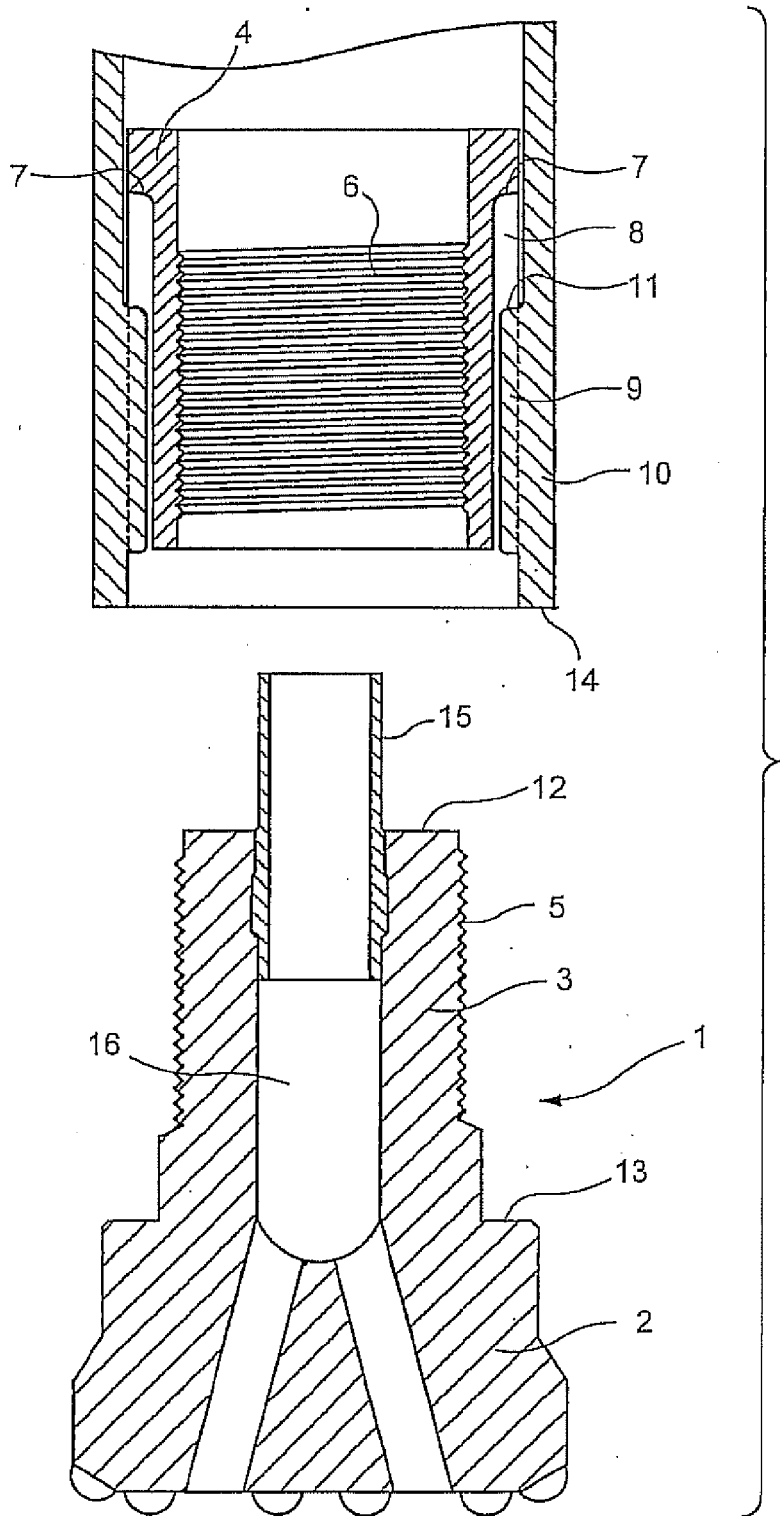

FIG. 1

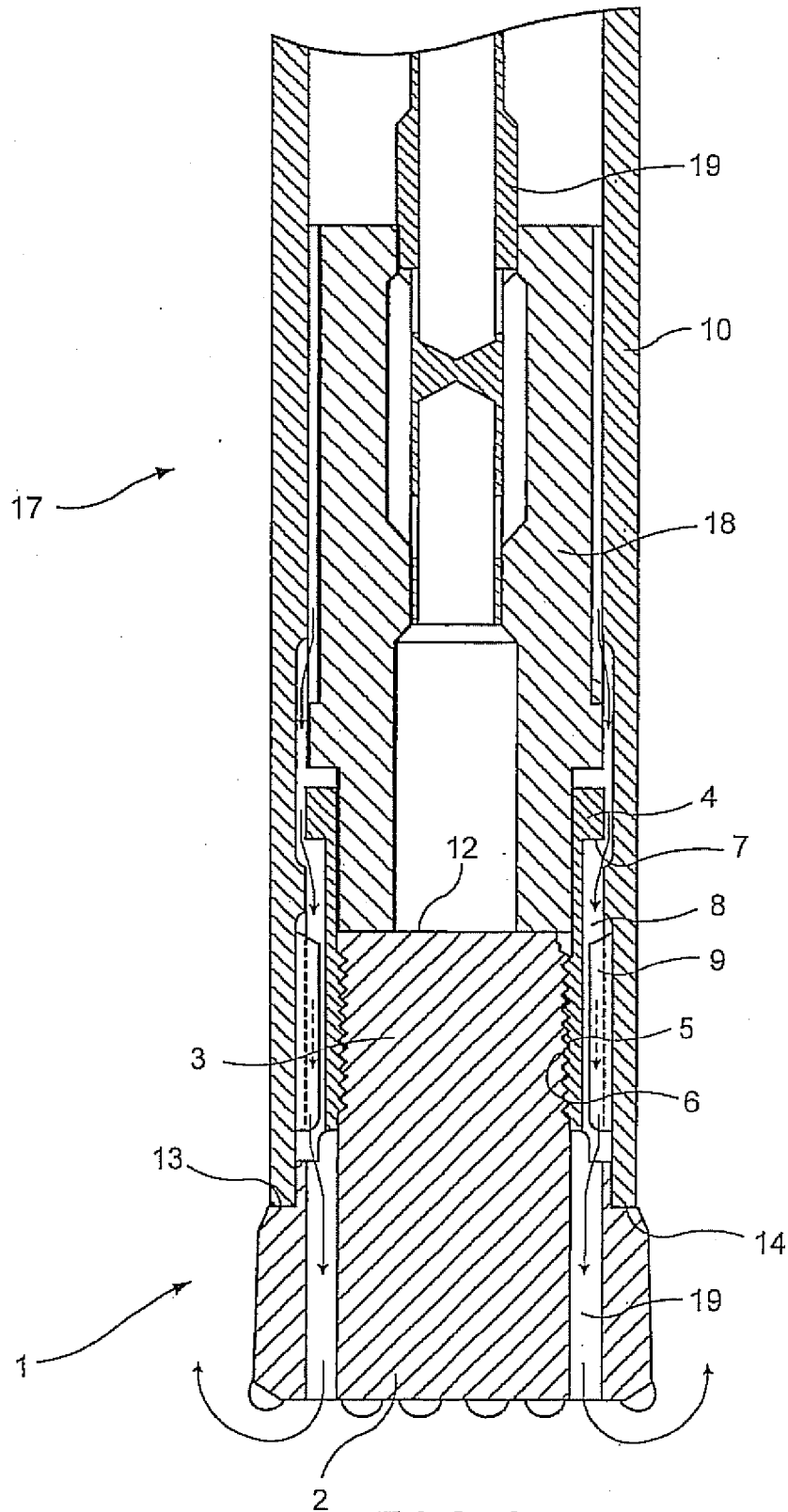

FIG. 2

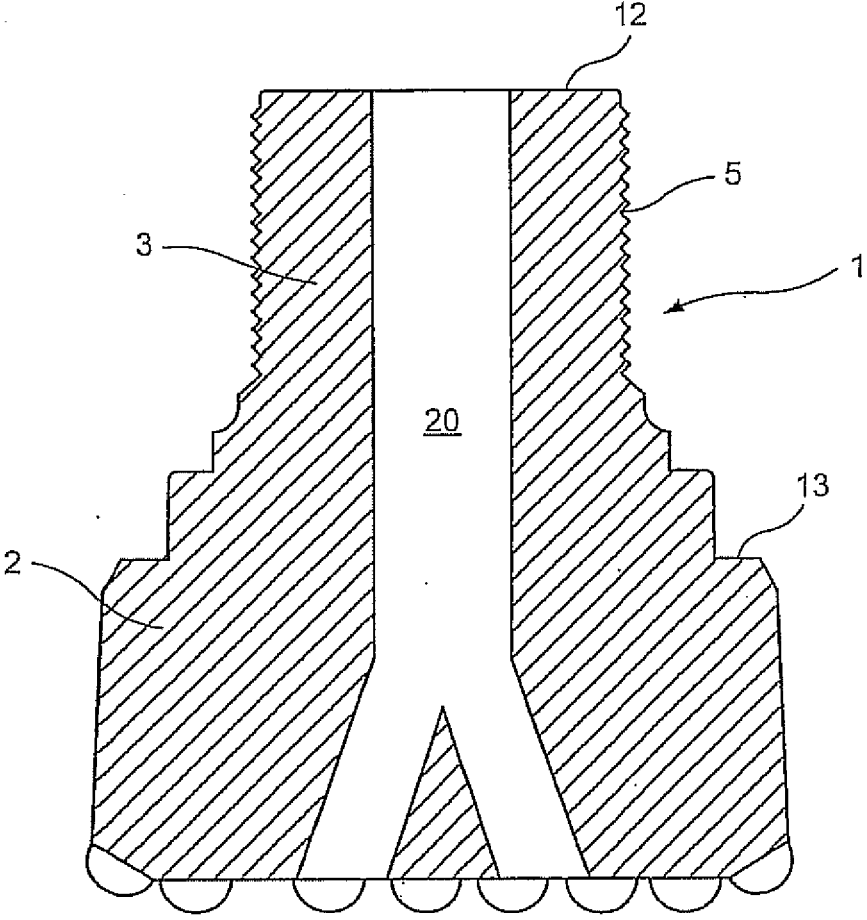

FIG. 3

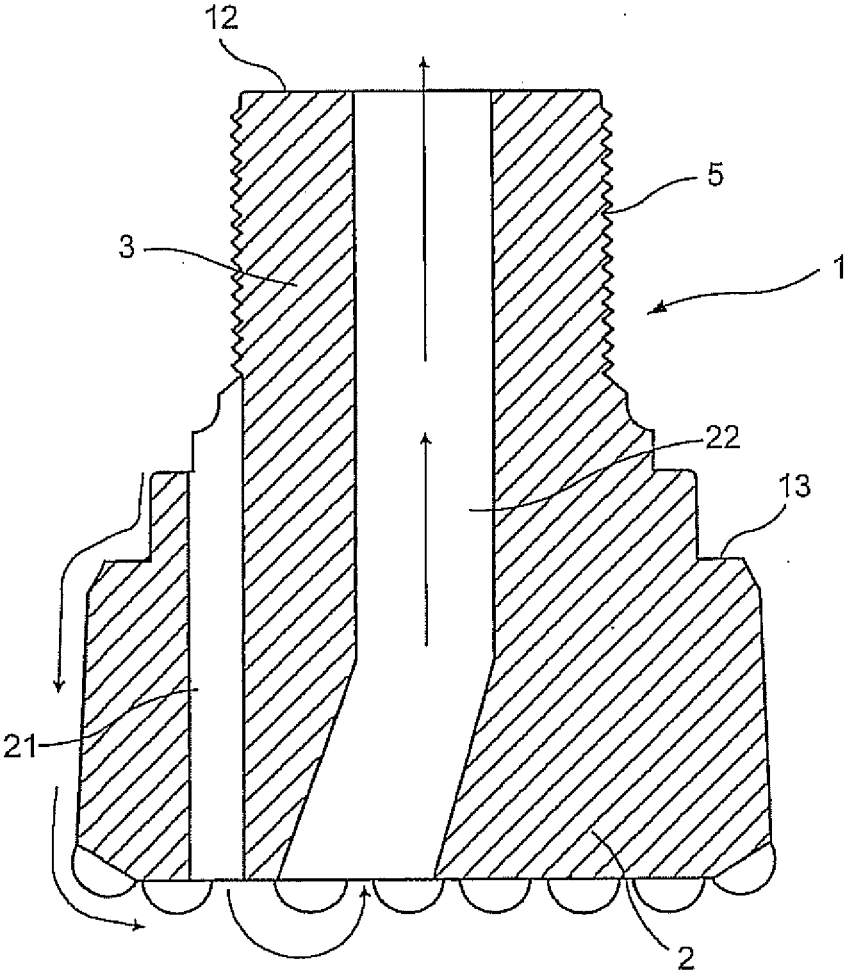

FIG. 4

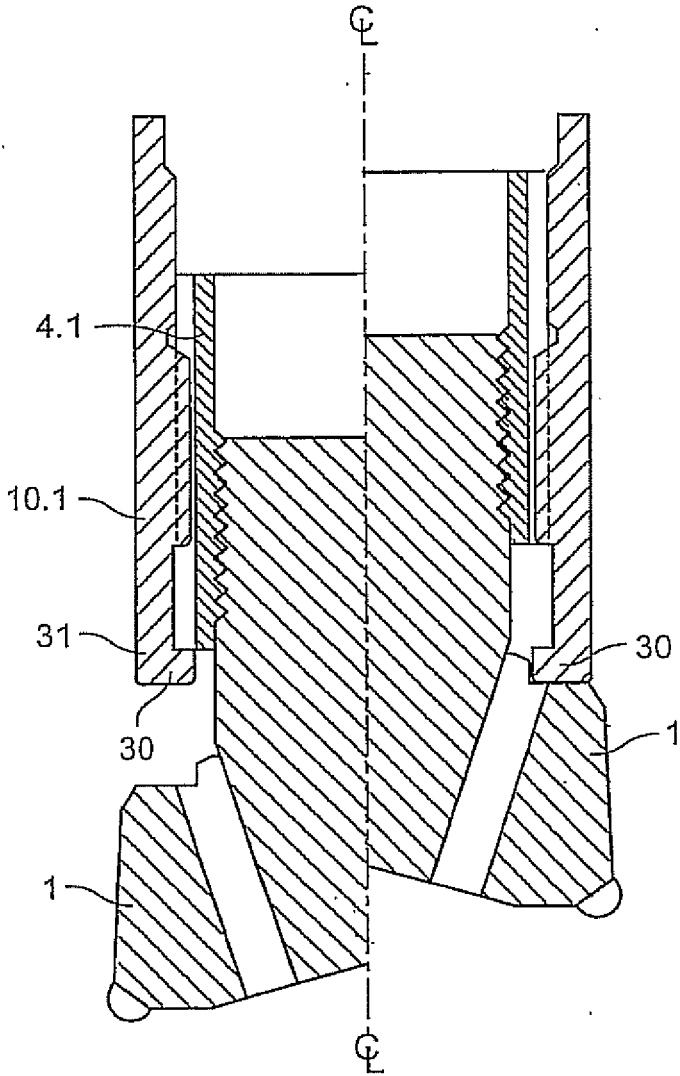

FIG. 5

## PERCUSSIVE DRILL BIT PROVIDED WITH AN IMPROVED CHUCK ASSEMBLY

### FIELD OF THE INVENTION

**[0001]** The invention relates to a drill bit for a down-the-hole drill hammer.

### BACKGROUND TO THE INVENTION

**[0002]** Drill bits of this kind conventionally have a shank which fits inside the drill housing and an exposed head at the forward end. The head is provided with teeth on a drilling face at its working end. The shank has splines which are engaged by corresponding splines in a chuck secured in the drill hammer. The rear end of the bit shank forms a striking face onto which a reciprocating piston hammer impacts during operation. Between the striking face and the splines, is a section of reduced diameter. This section defines a pair of shoulders between which a retaining ring, normally above the chuck, slidably engages the bit. The section of reduced diameter has to be longer than the axial thickness of the retaining ring. This allows for the necessary axial or longitudinal movement of the bit.

**[0003]** The drill hammers operate with different air flow paths which sometimes require the bit to include a foot valve tube. There is however a tendency towards drill hammers with bits that do not require these tubes.

**[0004]** The features required on a bit make this component a difficult one to machine. They also dictate that it must be of a certain minimum length which affects its weight and the overall length of the drill hammer. A drill hammer will ordinarily use about five bits during the course of its life.

### OBJECT OF THE INVENTION

**[0005]** It is an object of the current invention to provide a drill bit that is simpler and easier to manufacture.

### SUMMARY OF THE INVENTION

**[0006]** In accordance with this invention there is provided a drill bit for a down-the-hole drill hammer comprising a head with a shank adapted to be releasably secured in a reciprocating chuck.

**[0007]** The invention further provides for the rear end of the shank to provide a striking face; for the shank to be screw threaded along its length; and for the chuck to be externally splined with an outwardly extending shoulder at or near its rear end.

### BRIEF DESCRIPTION OF THE DRAWINGS

**[0008]** These and other features of the invention will be further described, by way of example only, with reference to the accompanying drawings, wherein:

**[0009]** FIG. 1: shows a cross-sectional side view of one embodiment of a drill bit with a foot valve tube; and

**[0010]** FIG. 2: shows a cross-sectional side view of another embodiment of a bit in a drill hammer;

**[0011]** FIG. 3: shows still another embodiment of a bit without a foot valve tube;

**[0012]** FIG. 4: shows yet another embodiment of a drill bit; and

**[0013]** FIG. 5: shows another embodiment of a chuck and wear sleeve.

### DETAILED DESCRIPTION OF THE INVENTION

**[0014]** Referring to FIG. 1, a drill bit (1) is shown having a head (2) at its forward end. Extending from the head (2) is a shank (3) which is adapted to be releasably secured in a reciprocating chuck (4). The shank (3) has screw threads (5) along its length. The chuck (4) is provided as a sleeve, with corresponding screw threads (6) along its inside adjacent its forward end.

**[0015]** An outwardly or laterally extending shoulder (7) is provided at the rear end of the chuck (4). The exterior of the chuck (4) from the shoulder (7) to its forward end is splined with the shoulder (7) formed between the splines (8). The splines (8) of the chuck (4) engage in corresponding splines (9) in the wear sleeve or housing (10) of a drill hammer. The rear end of each of the splines (9) provides a shoulder (11) to retain the chuck (4) in the wear sleeve (10).

**[0016]** When the drill hammer is assembled, the chuck (4) is inserted from the rear of the wear sleeve (10). The chuck (4) slides forward and once the splines (8) and (9) mesh, the shoulder (7) of the chuck (4) will abut the shoulders (11) in the wear sleeve (10). The remainder of the drill hammer components are then fitted to complete the assembly.

**[0017]** The drill bit (1) can then be fitted by screwing it into fixed engagement with the chuck (4). The chuck (4) is thus secured around the shank (3) which provides, at its rear end, a striking face (12) for the bit (1).

**[0018]** During operation of the drill, the shoulders (7) and (11) limit the forward stroke of the bit (1) when the striking face (12) at its rear end is impacted by the piston hammer (not shown). The shoulder (13) provided around the rear of the head (2) will stop against the forward end (14) of the wear sleeve (10) when the bit (1) is lifted.

**[0019]** This embodiment of the drill bit (1) has a foot valve tube (15) and axial exhaust passage (16) which opens through the drilling face of the head (2). Two further embodiments of the drill bit (1), which do not have such a tube, are shown in

**[0020]** FIGS. 2 and 3 respectively. The same reference numerals from FIG. 1 are used for corresponding components in the other two figures.

**[0021]** The drill bit (1) of FIG. 2 is provided in a drill hammer (17) based on the disclosures of my South African Patent Number 2004/2256. That specification sets out the airflow paths of the operation cycle in some detail. That detail will not be repeated here.

**[0022]** The bit (1) and chuck (4) are shown in a lifted or rearward position, with the shoulder (13) on the head (2) against the forward end (14) of the wear sleeve (10). The piston (18) reciprocates under influence of pressurized air which comes down the control rod or air distributor (19). The forward end of the piston (18) is slidably received in the annular chuck (4) provided around the striking face (12). In this embodiment the chuck (4) thus operates as a piston stem bush from which the forward portion of the piston (18) is lifted to exhaust the lower chamber.

**[0023]** The exhaust paths from the upper and lower chambers at either end of the piston (18) are around the rear end and shoulder (7) of the chuck (4) past the splines (8) and (9) along the outside of the bit (1) and through passages (19) in the head (2).

**[0024]** In FIG. 3 another bit (1) is provided to operate with an embodiment of the drill hammer in FIG. 2 wherein the exhaust takes place through the centre of the bit (1), via

passage (20). A chuck suitable for a particular drill hammer of this type will be within the design competence of a person skilled in the art.

**[0025]** FIG. 4 shows another embodiment of a drill bit (1) in accordance with this invention but for use with a reverse circulation drill hammer (not shown). In such a hammer, the exhaust air travels around the outside of the head (2) and through passage (21) to the bottom of the hole. The drilled cuttings are then entrained in the flow of air upwardly through bore (22). The bore (22) communicates with through the drill hammer to a passage extending through the centre of dual rods (not shown) to the surface. This flow of exhaust air is indicated by the arrows in FIG. 4. Again, a suitable chuck will be within the design competence of a person skilled in the art.

**[0026]** It will be readily appreciated that the chuck (4.1) need not have an outwardly extending shoulder as illustrated in FIG. 1. The chuck (4.1) illustrated in FIG. 5 is splined throughout its entire length. The wear sleeve (10.1) has an inward lip (30) formed at its rear end (31) to retain the chuck (4.1) thereinside.

**[0027]** The invention provides a bit which can be used on most, if not all, types of down the hole drill hammers and

which is simpler to machine. Screw threads replace the usual splines and other structural features ordinarily required. These are then provided in the more expensive parts of a drill hammer, namely the reciprocating chuck and wear sleeve. The conventional retaining ring is also not required in the embodiments shown.

**[0028]** A person skilled in the art will appreciate that the limited sliding fit between the chuck and the wear sleeve can be achieved through means other than splines.

1. A drill bit for a down-the-hole drill hammer comprising a head with a shank adapted to be releasably secured in a reciprocating chuck.

2. A bit as claimed in claim 1 in which the rear end of the shank provides a striking face.

3. A bit as claimed in claim 1 in which the shank is screw threaded along its length.

4. A bit as claimed in claim 1 in which the chuck is externally splined.

5. A bit as claimed in claim 4, in which the chuck has an outwardly extending shoulder at or near its rear end.

\* \* \* \* \*