



US 20130334504A1

(19) **United States**

(12) **Patent Application Publication**

Thompson et al.

(10) **Pub. No.: US 2013/0334504 A1**

(43) **Pub. Date: Dec. 19, 2013**

(54) **ORGANIC LIGHT EMITTING DIODE LIGHTING DEVICES**

Publication Classification

(71) Applicant: **Plextronics, Inc.**, (US)

(51) **Int. Cl.**
H01L 51/52 (2006.01)

(72) Inventors: **Glenn Thompson**, Butler, PA (US);
Mark L. Storch, Pittsburgh, PA (US);
Mathew K. Mathai, Gibsonia, PA (US);
Troy D. Hammond, Pittsburgh, PA (US)

(52) **U.S. Cl.**
CPC *H01L 51/5203* (2013.01)
USPC **257/40; 257/99**

(73) Assignee: **Plextronics, Inc.**, Pittsburgh, PA (US)

(57) **ABSTRACT**

(21) Appl. No.: **13/850,165**

An organic light emitting diode (OLED) device includes a substrate, an anode, a cathode, an active region including an organic material, wherein the active region is electrically coupled to the anode and the cathode, at least one coupler configured to electrically couple at least one of the anode or the cathode to a power supply, and an encapsulation that isolates the active region from an ambient environment. A lighting system can be made including a plurality of OLED devices. A lighting system can be assembled using the OLED devices from a kit. The OLED devices may be polymer light emitting diode (PLED) devices or small molecule light emitting diode (SMOLED) devices. The OLED devices can use regio-regular poly-thiophene.

(22) Filed: **Mar. 25, 2013**

Related U.S. Application Data

(62) Division of application No. 12/543,225, filed on Aug. 18, 2009, now Pat. No. 8,414,304.

(60) Provisional application No. 61/090,150, filed on Aug. 19, 2008.

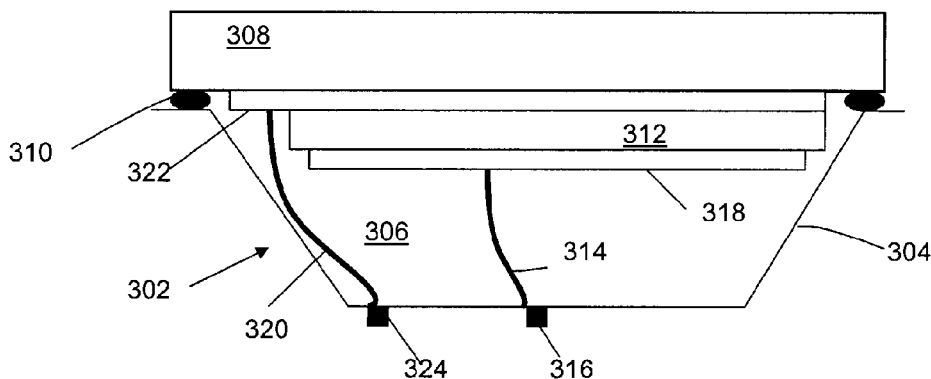

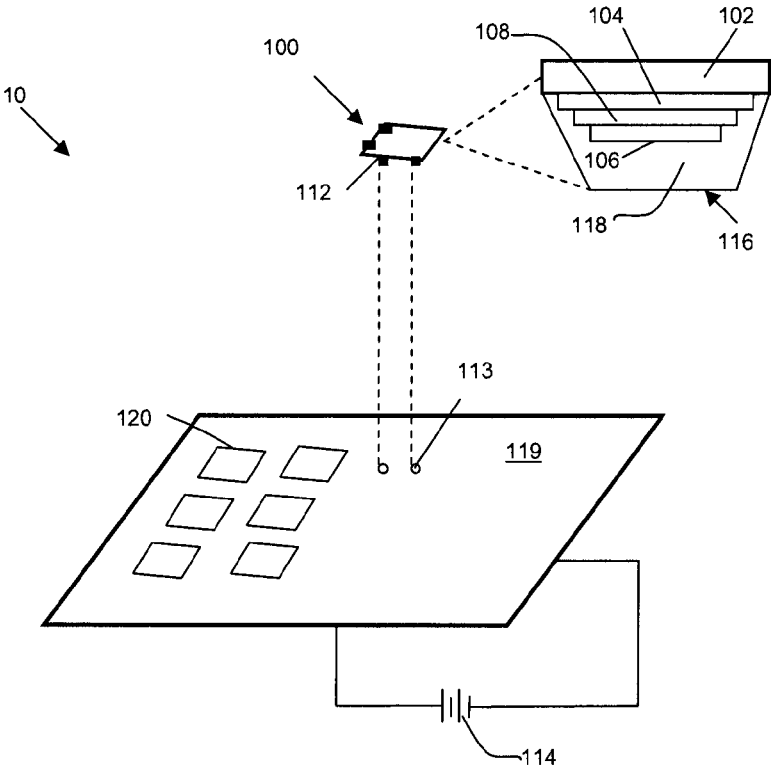

FIG. 1

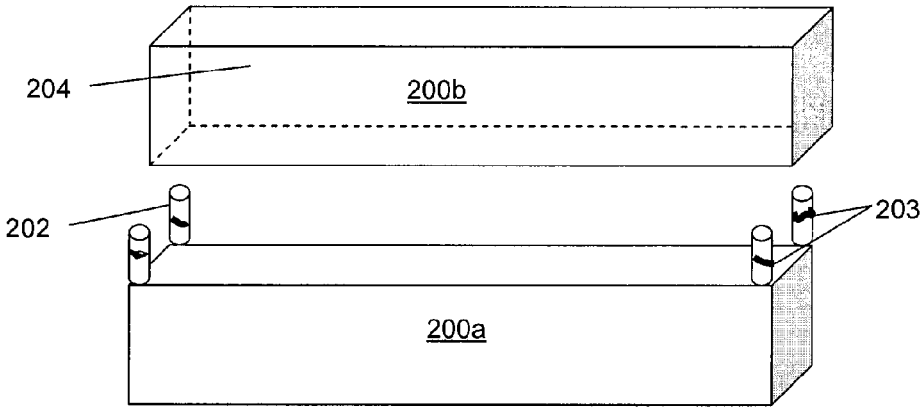

FIG. 2A

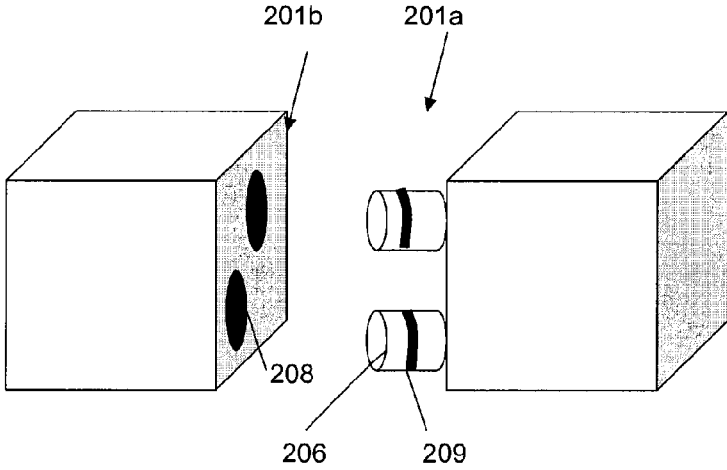

FIG. 2B

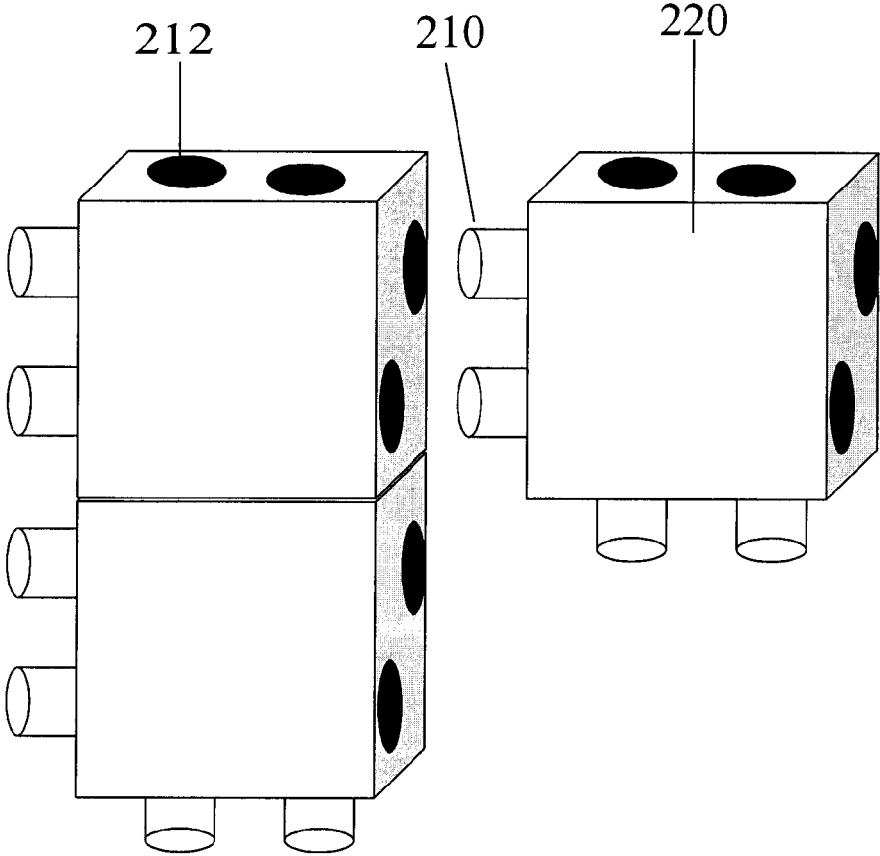

FIG. 2C

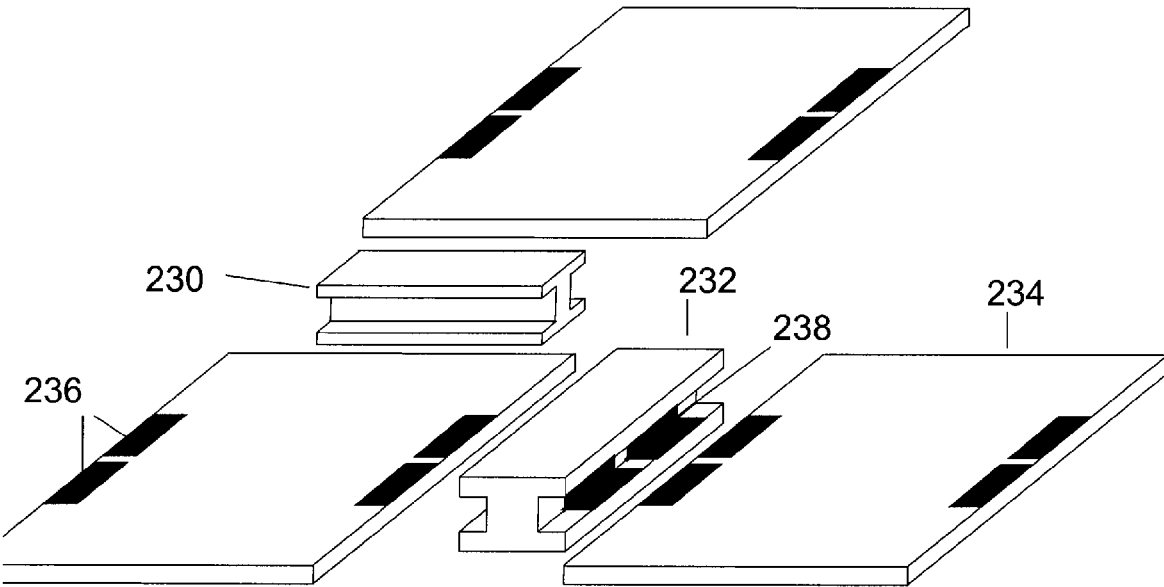

FIG. 2D

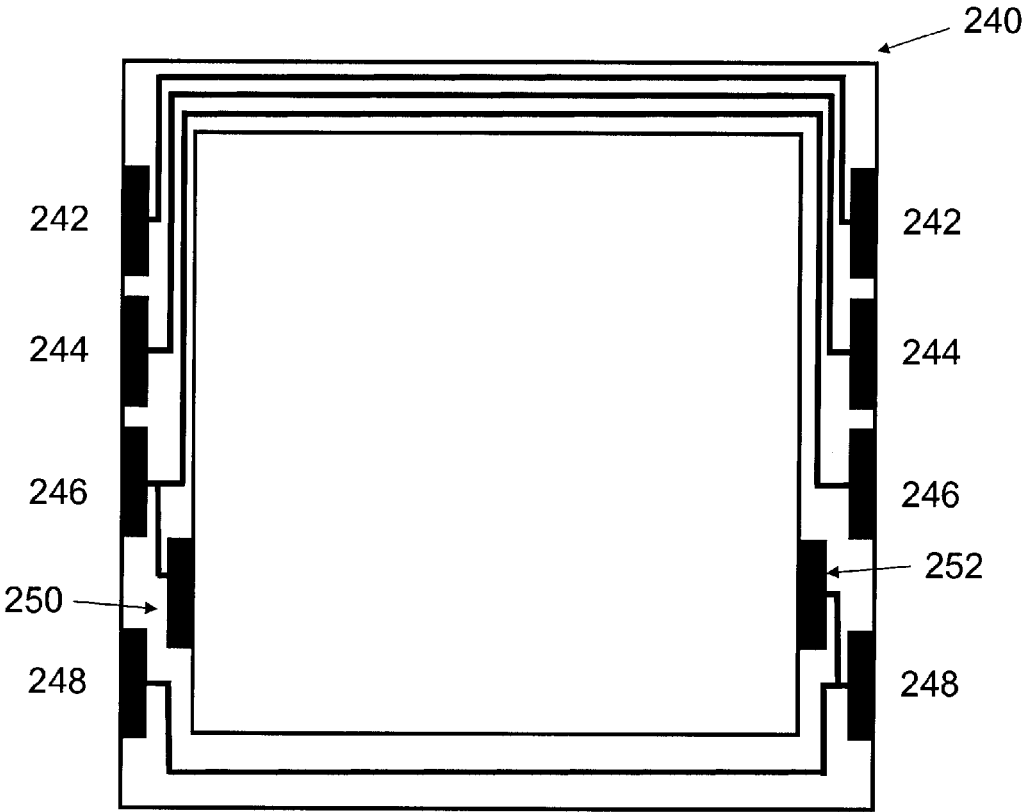

FIG. 2E

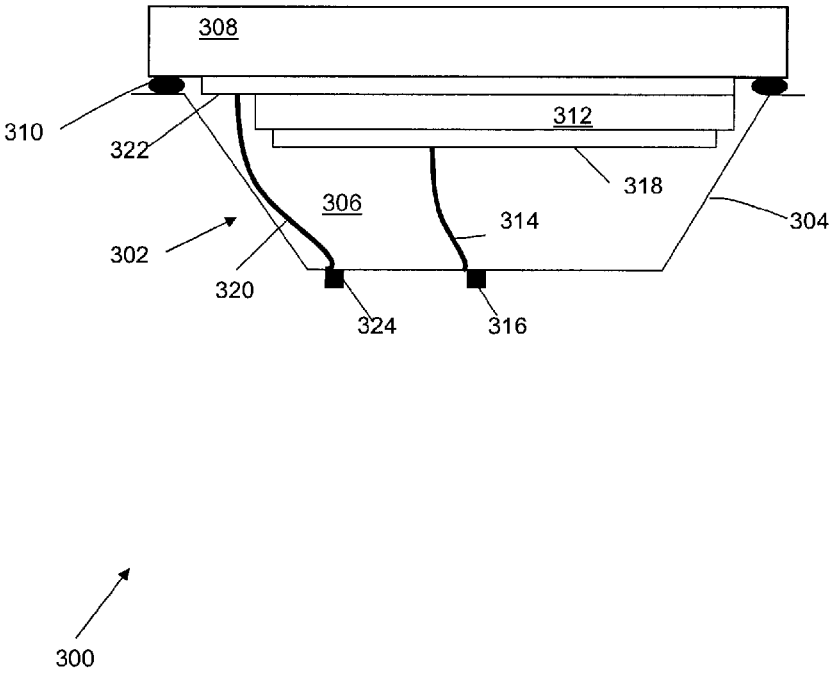

FIG. 3

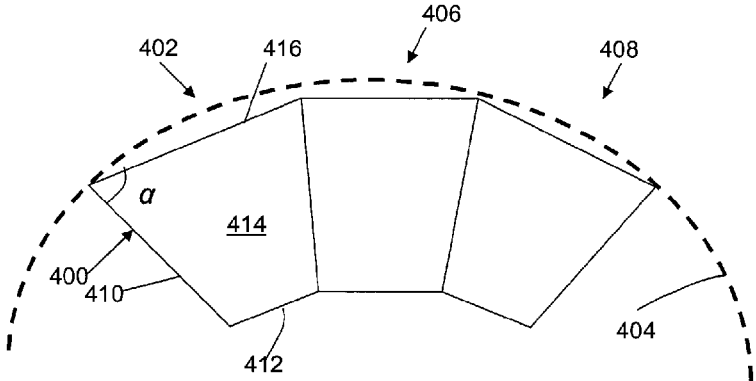

FIG. 4

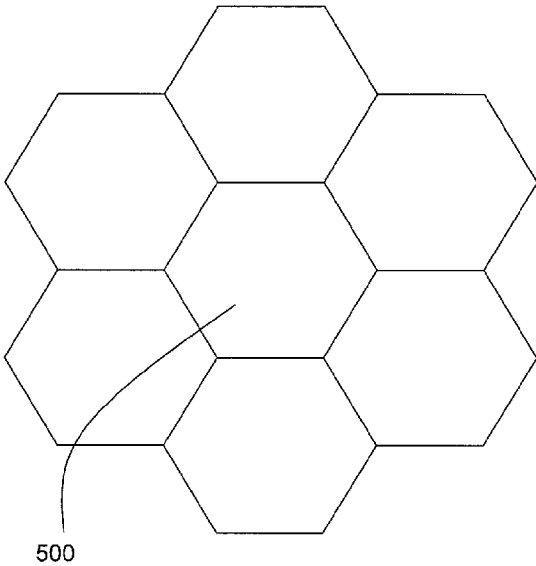

FIG. 5

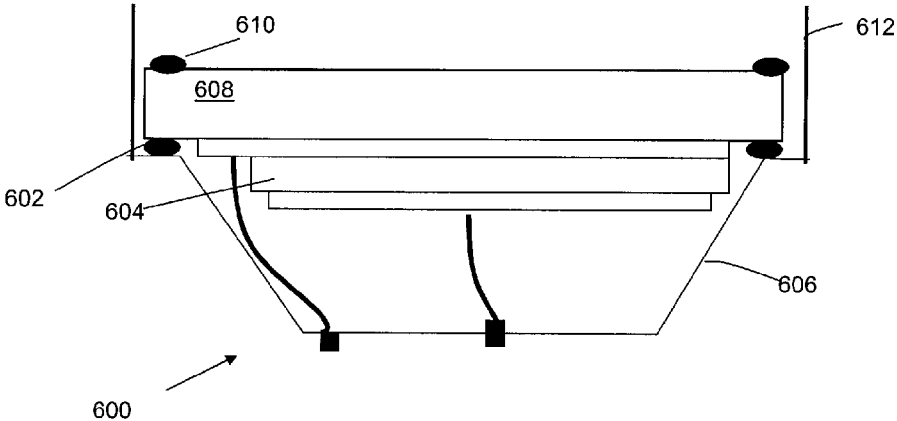

FIG. 6A

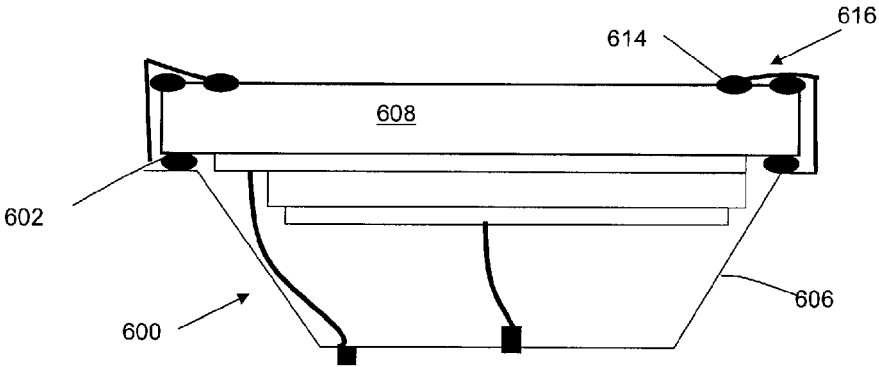

FIG. 6B

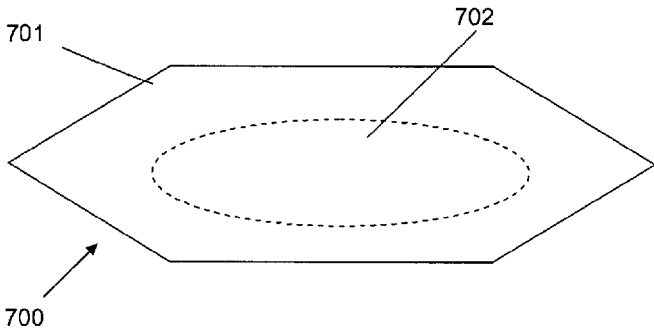

FIG. 7A

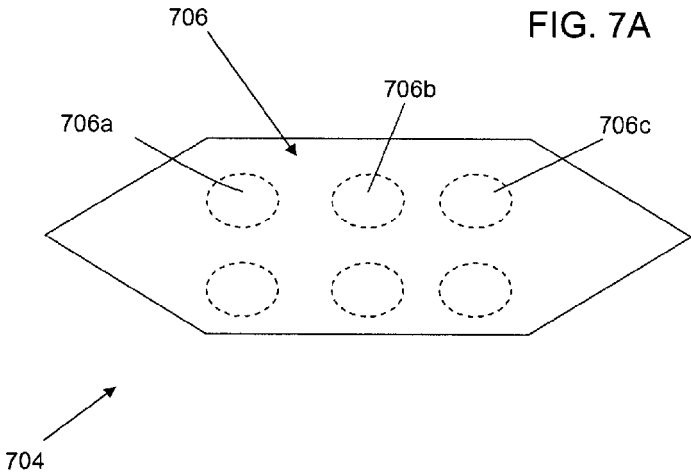

FIG. 7B

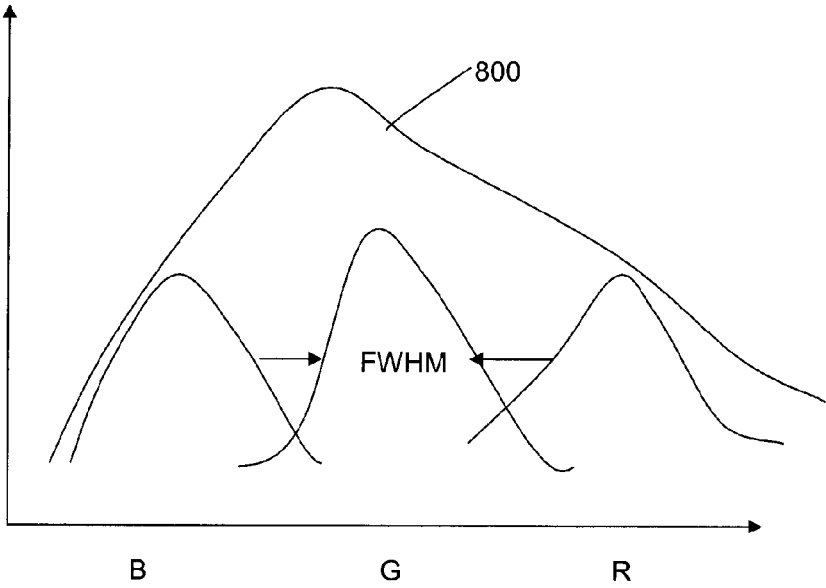

FIG. 8

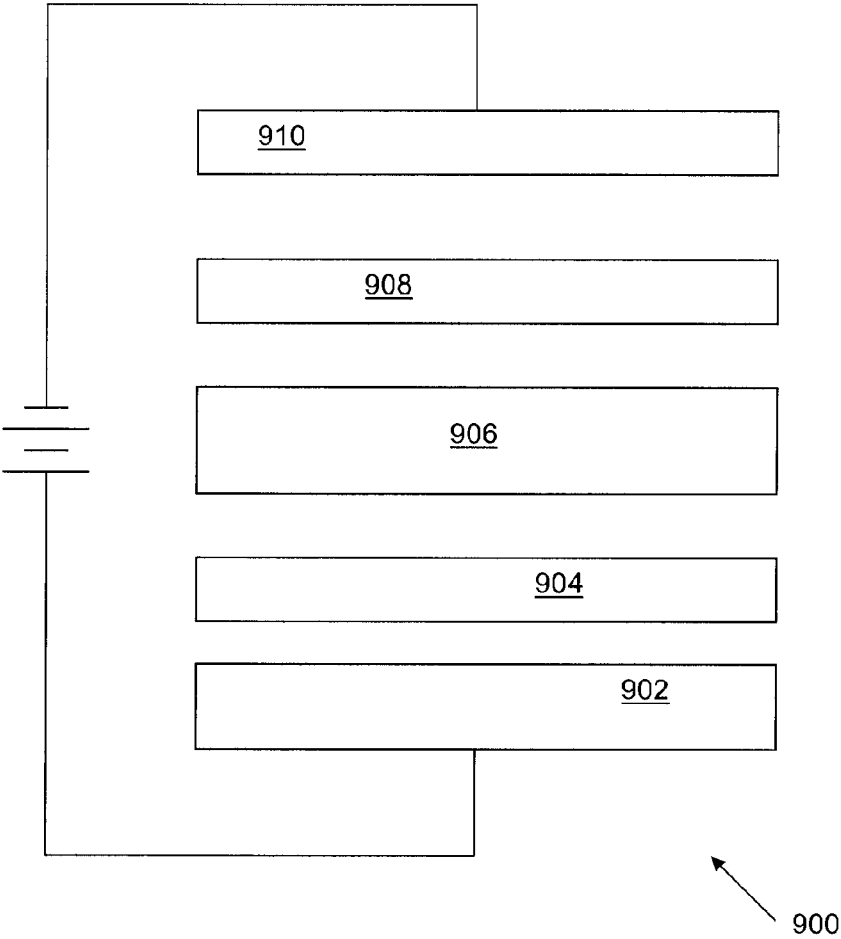

FIG. 9

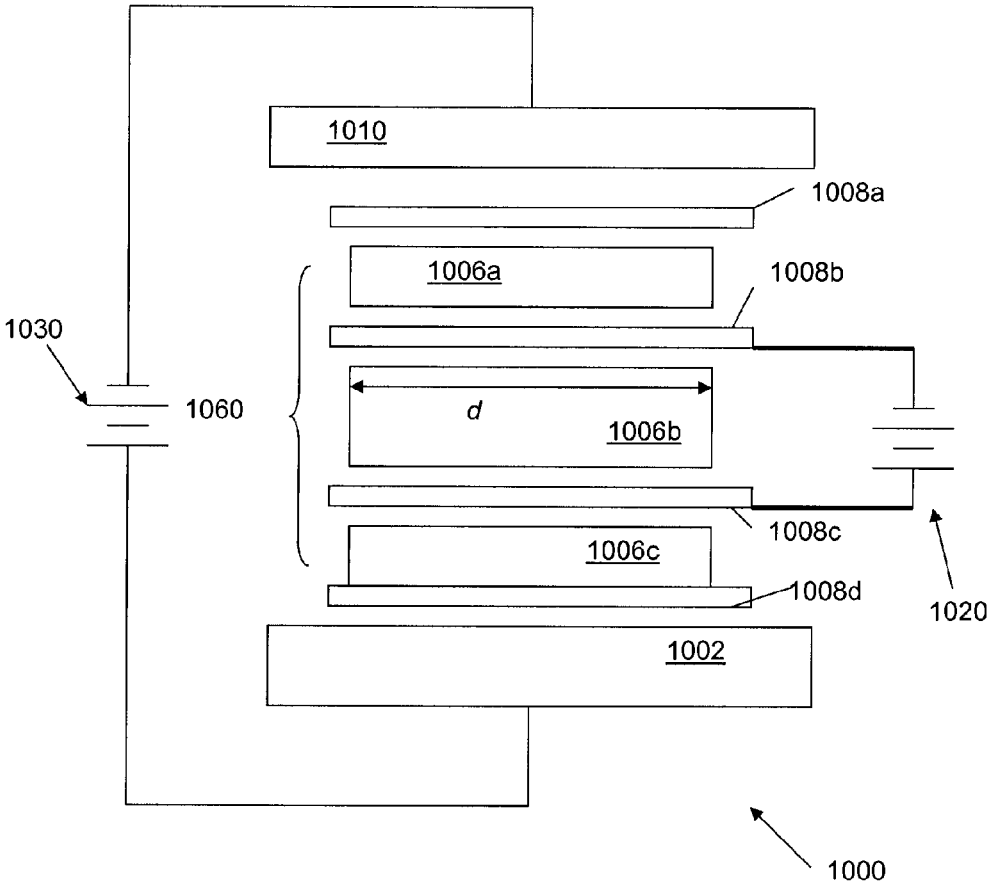

FIG. 10

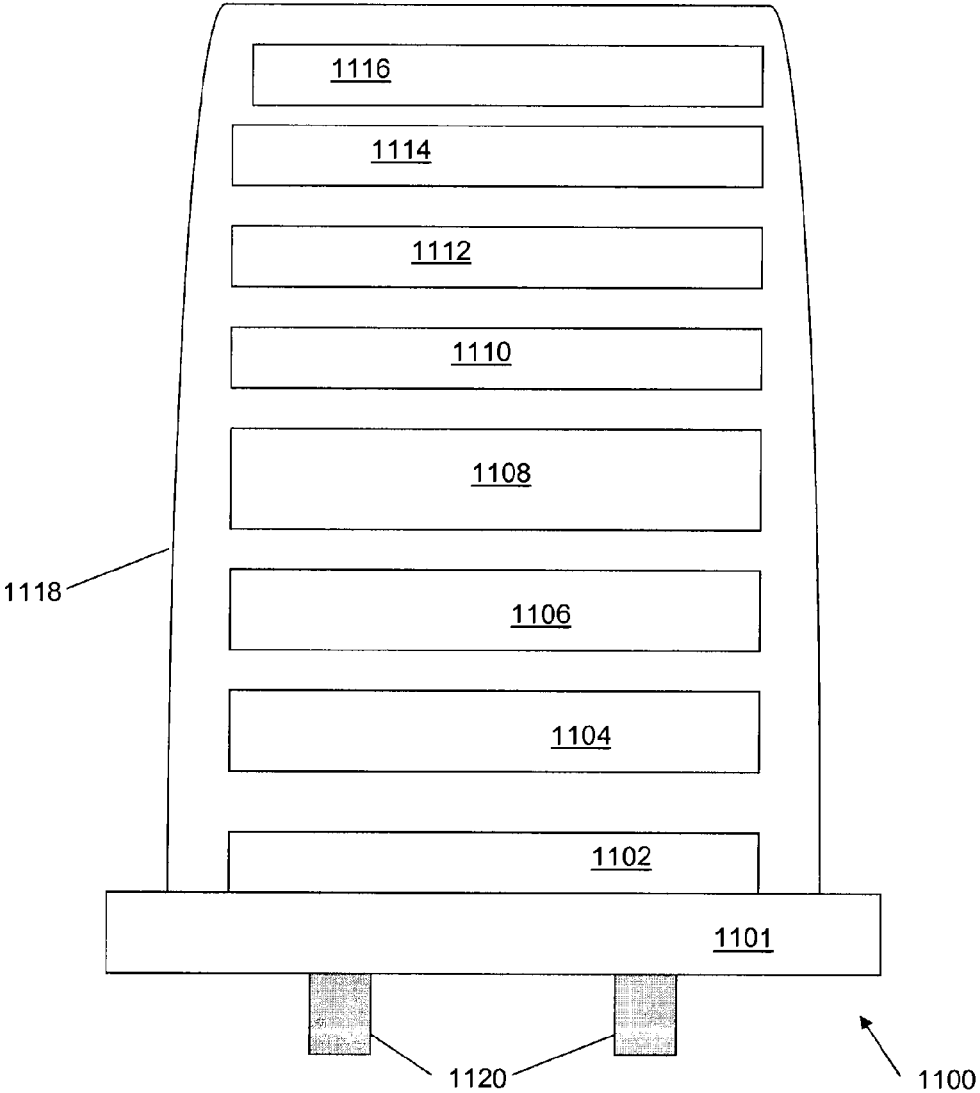
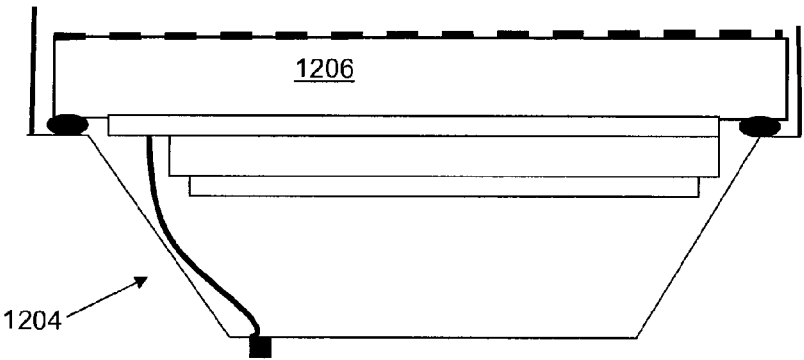
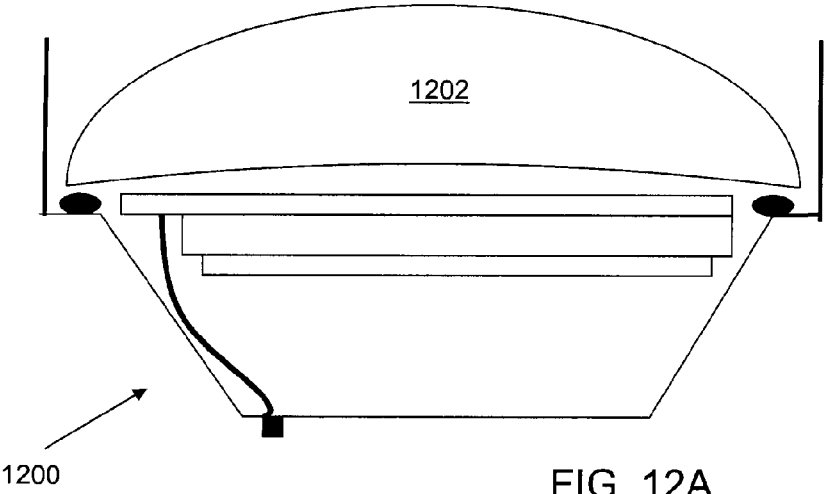

FIG. 11



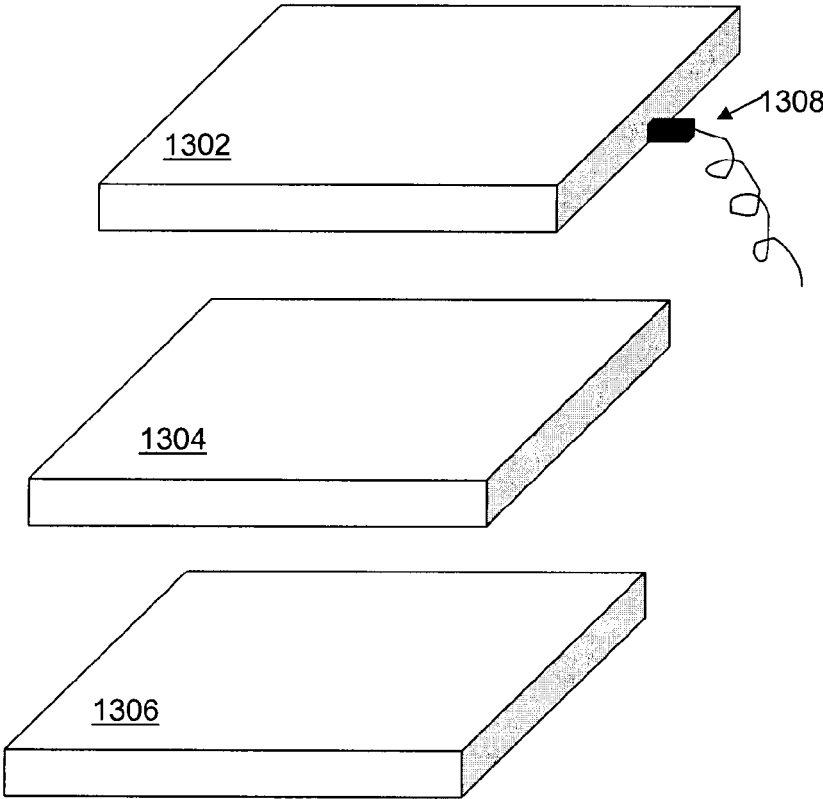

FIG. 13

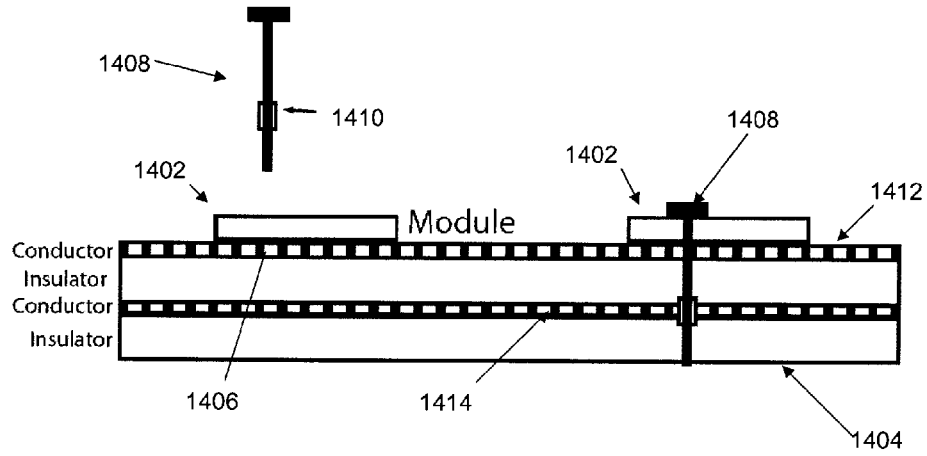

FIG. 14A

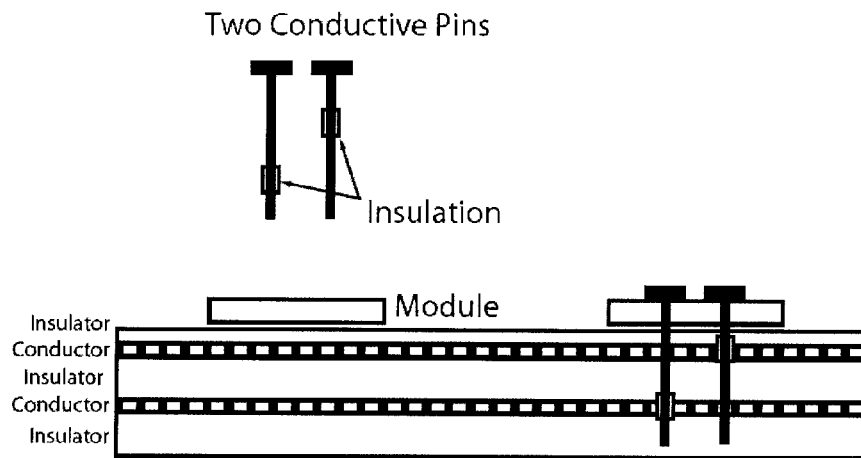

FIG. 14B

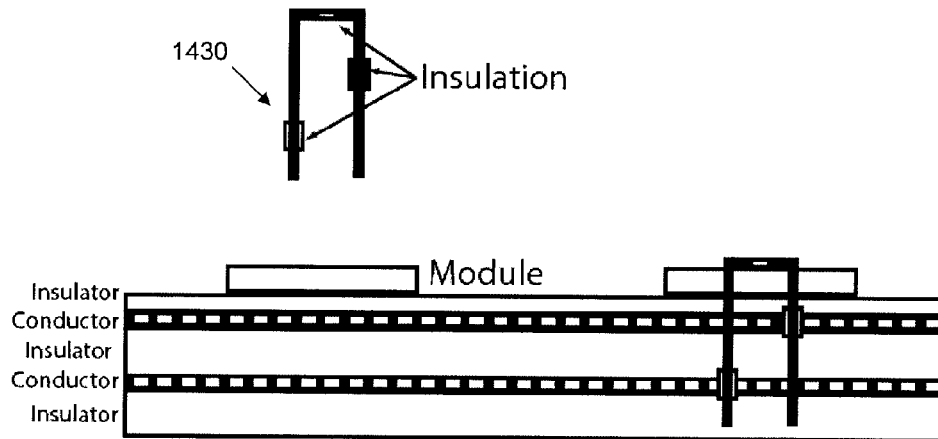

FIG. 14C

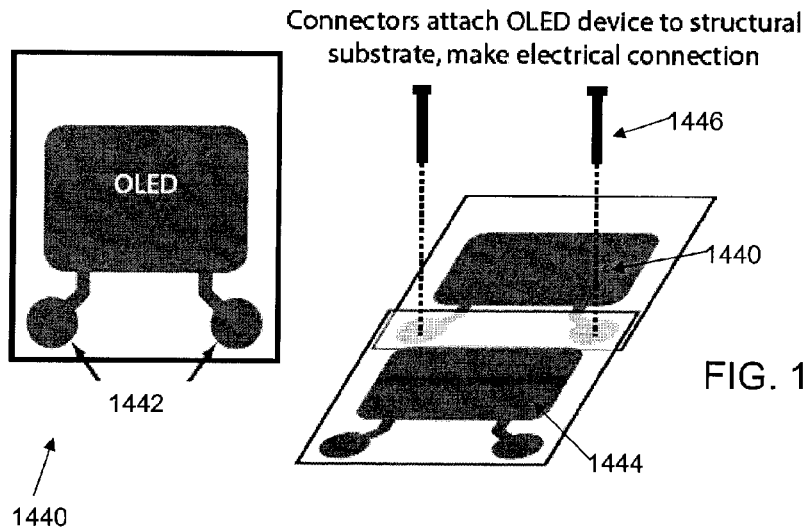

FIG. 14D

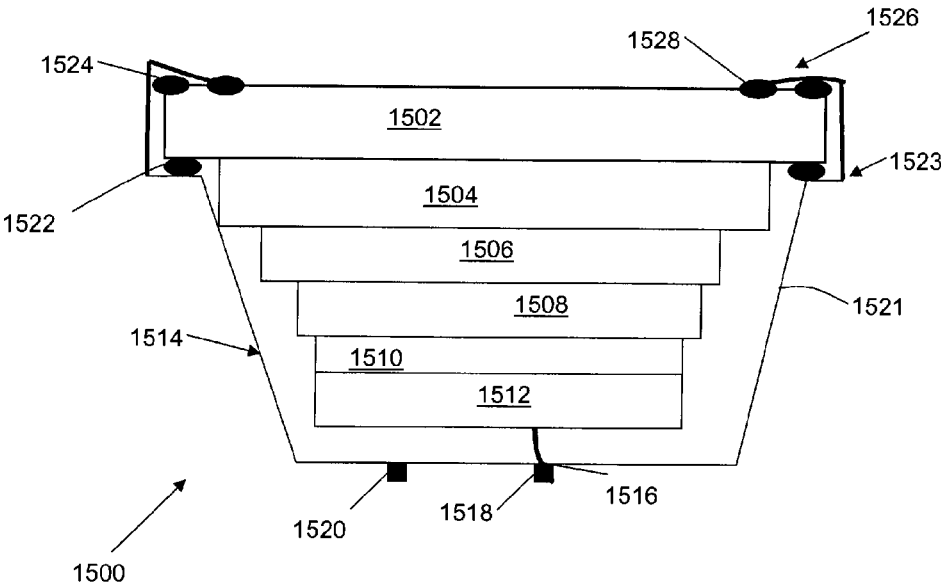

FIG. 15

**ORGANIC LIGHT EMITTING DIODE
LIGHTING DEVICES****CROSS-REFERENCE TO RELATED
APPLICATIONS**

[0001] This application claims priority to U.S. Provisional Patent Application No. 61/090,150, filed on Aug. 19, 2008, the complete disclosure of this application being hereby incorporated by reference in its entirety.

BACKGROUND

[0002] Organic light emitting diodes (OLEDs) can utilize organic small molecules or polymers that produce light when transferred into their excited state by an external power source. Accordingly, OLED devices may be referred to as polymer light emitting diode (PLED) devices or small molecule organic light emitting diode (SMOLED) devices depending on their active compositions. Earlier OLEDs were typically based on relatively simple structures, where a thin layer of the electroluminescence (EL) conjugated polymer was enclosed between a pair of electrodes. When a voltage is applied to the electrodes, the positive (anode) and the negative (cathode) electrodes can provide injection of holes and electrons, respectively, into the EL polymer. In the EL polymer layer, electrons and holes move towards each other in the applied electrical field and form excitons, which are bound excited states that can relax down into the ground state radiatively by emitting a photon. This process can be referred to as electroluminescence. OLED devices are of interest in, for example, display, signage, and lighting.

[0003] OLEDs were first designed in the 1980s, see, e.g., C. W. Tang, S. A. Van Slyke, *Organic electroluminescent diodes*, *Appl. Phys. Lett.* 1987, 51, 913. More recent developments in OLED materials and applications are generally described in Kraft et al., *Angew. Chem. Int. Ed.*, 1998, 37, 402-428, and Z., Li and H. Meng, *Organic Light-Emitting Materials and Devices* (Optical Science and Engineering Series), CRC Taylor & Francis (Sep. 12, 2006). The disclosures of these references are incorporated by reference in their entirety.

SUMMARY

[0004] Described herein are embodiments which include, among other things, devices, articles, instruments, apparatuses, kits, systems, and the like, and methods of making and methods of using same. More specifically, the various embodiments described herein generally relate to individual light emitting diode (LED) devices, and lighting systems comprising LEDs. In particular, the embodiments are related to the use of organic light emitting diodes (OLED) in lighting.

[0005] In one aspect, an OLED device is provided. The OLED device includes a substrate, an anode, a cathode, an active region comprising an organic material, wherein the active region is electrically coupled to the anode and the cathode with at least one coupler configured to electrically couple at least one of the anode or the cathode to a power supply, and an encapsulation that isolates the active region from an ambient environment.

[0006] In another aspect, an OLED device is provided, which includes a substrate, an anode, a cathode, and an active region comprising an organic material, wherein the active region is electrically coupled to the anode and the cathode, at least one coupler configured to electrically couple at least one of the anode or the cathode to a power supply, and an encapsulation that isolates the active region from an ambient environment, wherein the active region comprises a plurality of vertically-stacked light emitting layers. The light emitting layers may be interlaced with multiple electrodes such that the light emitting layers may be individually addressed and controlled.

[0007] In another aspect, an OLED device is provided, which includes a substrate, a first anode, a hole injection layer adjacent the first anode, a first light emitting layer, a first cathode, a second anode, a second light emitting layer, an electron transport layer, a second cathode, at least one coupler configured to electrically couple at least one of the first anode, the second anode, the first cathode, or the second cathode to a power supply, and an encapsulation that isolates the first and second light emitting layers from an ambient environment, wherein each of the first or second light emitting layers comprises an organic material, and wherein the first and second light emitting layers are electrically coupled to their respective first and second anodes and cathodes.

[0008] In another aspect, a lighting kit of pre-manufactured modular OLED devices is provided. The OLED devices may include OLED devices of different colors, shapes, or sizes, each OLED device including a substrate, an anode, a cathode, and an active region including an organic material, wherein the active region is electrically coupled to the anode and the cathode, at least one coupler configured to electrically couple at least one of the anode or the cathode to a power supply, and an encapsulation that isolates the active region from an ambient environment.

[0009] In another aspect, an OLED device is provided, which includes a substrate, an anode, a cathode, an active region comprising an organic material, wherein the active region is electrically coupled to the anode and the cathode, an encapsulation that isolates the active region from an ambient environment, and a plurality of electrodes, wherein at least one of which is electrically isolated from the active region of the OLED device. The electrically isolated electrodes may be used to provide an electrical connection between couplers, to pass current from one OLED device to the next without activating the OLED device.

[0010] In another aspect, a lighting system is provided. The lighting system includes a plurality of organic light emitting diode (OLED) devices, wherein each of the OLED devices includes a substrate, an anode, a cathode, an active region comprising an organic material, wherein the active region is electrically coupled to the anode and the cathode, at least one coupler configured to electrically couple at least one of the anode or the cathode to a power supply, and an encapsulation that isolates the active region from an ambient environment.

[0011] In another aspect, a lighting system is provided. The lighting system includes a plurality of OLED devices and a plurality of couplers that have indentations or protrusions oriented in the lateral direction to connect to OLED device edges. Each of the OLED devices includes a substrate, an anode, a cathode, an active region comprising an organic material, wherein the active region is electrically coupled to the anode and the cathode, and an encapsulation that isolates the active region from an ambient environment.

[0012] In another aspect, an OLED device is provided. The OLED includes multiple electrodes, wherein at least one electrode is electrically isolated from the active region of the OLED device.

[0013] In another aspect, a coupler is provided. The coupler includes indentations or protrusions, wherein the coupler is

configured to provide at least one of an electrical or mechanical coupling of at least one OLED device to a mount or to another OLED device.

[0014] At least one advantage from at least one embodiment is that the OLED device is a “plug and play” device and can be readily placed into a system and/or replace an existing device. The encapsulation and the coupler allow the OLED device to be a standalone device.

[0015] At least another advantage from at least one embodiment is the large area light emitting source as a result of using organic materials. The ease of manufacturing, and the tunable color with the desirable visual effect are provided by the organic material.

BRIEF DESCRIPTION OF FIGURES

[0016] FIG. 1 is a perspective view of an example OLED device implemented in a lighting system;

[0017] FIGS. 2A, 2B, 2C, and 2D are perspective views of example OLED device couplers;

[0018] FIG. 2E is a perspective view of an example OLED device compatible with the coupler shown in 2D;

[0019] FIG. 3 is a cross-sectional view of an example OLED device packaged in an encapsulation;

[0020] FIG. 4 is a cross-sectional view of a plurality of example packaged OLED devices tightly arranged on a curved surface;

[0021] FIG. 5 is a top plan view of a plurality of example hexagonal OLED devices tightly arranged into a matrix;

[0022] FIGS. 6A and 6B are cross-sectional views of a further sealed example OLED device;

[0023] FIG. 7A is a perspective view of an example OLED device with a single, continuous active region;

[0024] FIG. 7B is a perspective view of an example OLED device with a plurality of active regions;

[0025] FIG. 8 illustrates example emission spectra of individual OLED devices and their mixed output spectrum;

[0026] FIG. 9 is a cross-sectional view of an example OLED device with multiple layers that help improve the light emitting efficiency;

[0027] FIG. 10 is a cross-sectional view of an example OLED device with multiple active layers;

[0028] FIG. 11 is a cross-sectional view of an example of a vertically stacked OLED device structure;

[0029] FIGS. 12A and 12B are cross-sectional views of example OLED devices having light-out coupling layers to improve light output efficiency;

[0030] FIG. 13 is a perspective view of an example of a stacked OLED device assembled from a lighting kit of pre-manufactured, modular OLED devices;

[0031] FIGS. 14A-14C are cross-sectional views of example elongated conductors used in forming a stacked OLED device;

[0032] FIG. 14D is a schematic diagram illustrating a plurality of example OLED devices being coupled using elongated conductors; and

[0033] FIG. 15 is a cross-sectional view of an example of a pre-manufactured, modular OLED device.

DETAILED DESCRIPTION

Introduction

[0034] All references cited in this application are hereby incorporated by reference in their entirety.

[0035] The use of organic materials in electroluminescent devices offers several desirable properties, for example, increased luminescence of the device; lower threshold voltage; ease of processability of materials and components during device fabrication; the ability to use spin casting, drop casting, and printing techniques to apply different layers in electroluminescent devices; the ability to prepare flexible electroluminescent devices; the ability to prepare low-weight electroluminescent devices; and the ability to prepare low-cost electroluminescent devices.

[0036] An electroluminescent device generally can be an electrochemical device that converts electrical current to electromagnetic radiation. In particular, OLEDs provide an efficient way to produce light at low voltage and minimal radiant heat. These devices currently find uses in many consumer electronics such as displays, signage, and lighting. OLEDs are generally known in the art as described in, for example, *Organic Light-Emitting Materials and Devices*, edited by Li and Meng, 2007.

Plug-in OLED Device for a Lighting System

[0037] An example OLED device **100** is illustrated in FIG. 1 as part of a lighting system **10**. The OLED device **100** can comprise a substrate **102**, an anode **104**, a cathode **106**, and an active region **108**. The active region **108** comprises an organic material, and is electrically coupled to the anode **104** and the cathode **106**. The active region **108** is configured to emit a broadband emission spectrum, for example, with a full width at half maximum (FWHM) larger than about 50 nm. The OLED device **100** has a typical structure with the anode adjacent to the substrate and the cathode over the active region. An inverted structure can also be used in which the cathode is adjacent to the substrate and the anode is over the active region.

[0038] The OLED device **100** can have a plurality of couplers **112** configured to couple the OLED device **100** to a mount **119** through indentations **113**. The couplers **112** can be mechanical couplers, or can be used also to electrically couple the anode **104** or the cathode **106** to a power supply **114** through the mount **119**. In one embodiment, the couplers **112** are used for both electrical coupling and mechanical coupling. The couplers may be fixedly or removably attached to the OLED device.

[0039] The OLED device **100** also can have an encapsulation **116** that isolates the active region **108** from an ambient environment. In particular, the encapsulation **116** prevents water vapor and oxygen from entering the enclosure **118** to interact with the organic material in the active region **108**. With the couplers **112** and the encapsulation **116**, the OLED device **100** may be readily used as a standalone device, or may be dropped into a lighting system to replace another device.

[0040] The couplers **112** may be configured to electrically couple at least one of the anode **104** or the cathode **106** with the power supply **114** via the mount **119**. The mount **119** may also be referred to as the “system substrate,” which provides a frame onto which the lighting system can be built. In addition to mechanical support, the mount **119** can also provide electrical paths for the OLED devices. The mount **119** may be flat or curved. The mount **119** can be flexible, and the resulting lighting system can be flexible in shape. The mount **119** may comprise one or more rails to which OLED devices are slidably coupled. The mount may be configured to be free-standing, ceiling mounted, or wall mounted. Since OLEDs are

Lambertian emitters, the mount needs not be designed to mix the light of OLEDs of various emission spectra.

[0041] Some of the couplers **112** may be configured to electrically couple at least one of the anode **104** or the cathode **106** with the power supply **114** via a second OLED device **120**. By selecting a plurality of OLED devices, a lighting system may be built with a desired color, pattern, area, and brightness.

[0042] In addition to the electrical coupling, the couplers **112** may also mechanically couple the OLED device with the mount **119** or with one or more OLED device **120**.

Substrate

[0043] Substrates are generally known in the art. Descriptions of various substrates may be found in, for example, Z., Li and H. Meng, *Organic Light-Emitting Materials and Devices* (Optical Science and Engineering Series). The substrate **102** of the OLED device **100** can be, for example, a solid substrate or a flexible substrate. The substrate can comprise, for example, an inorganic material or an organic material. The substrate can be, for example, made from glass, metal foil, or plastic. The substrate can be, for example, flat or curved. The substrate can be, for example, rigid, flexible or conformable. The substrate can be, for example, transparent, translucent, or opaque.

Anode

[0044] Anodes are generally known in the art. The anode **104** of the OLED device **100** can be transparent to the light emitted from the OLED device **100**. The anode **104** may comprise, for example, indium tin oxide (ITO). ITO in the form of thin layers (e.g., about 100 nm thick) is substantially transparent to visible light. Substantially transparent layers desirably allow a visible light transmission of about 70% or more. ITO has a relatively high work function that helps the injection of holes into the active region **108**. The ITO may be coated on a glass or plastic substrate.

Cathode

[0045] Cathodes are generally known in the art. The cathode **106** of the OLED device **100** can also be transparent. The cathode **106** may comprise, for example, a thin metal film such as aluminum or calcium, or a non-metal conductive layer. The cathode **106** may comprise a layer which is a combination of organic and inorganic components. The cathode **106** typically has a relatively low work function to help injecting electrons into the active region **108**. The cathode **106** can be at least 100-200 nm thick.

Active Region

[0046] The active region refers generally to the region where electrons and holes recombine to radiate photons. In the claimed embodiments, the active region comprises an organic material, and the radiative photon energy may correspond to the energy difference between the lowest unoccupied molecular orbital (LUMO) level and the highest occupied molecular orbital (HOMO) level of the organic material. Photons of lower energy/longer wavelength may be generated by higher-energy photons through fluorescent or phosphorescent processes.

[0047] The active region can comprise a light emitting layer. The active region can comprise multiple layers, for example, a combination of p- and n-type layers. The p- and

n-type materials may be bonded to each other. The bonding can be ionic or covalent bonding. The multiple layers of the active region may form heterostructures therebetween.

[0048] The active region may be manufactured by known methods including, for example, spin casting, drop casting, slot die coating, vapor deposition or sputtering, crystalline growth, patterned etching, dip coating, or by printing techniques such as ink jet printing, off-setting, transfer processes, or by spray applications.

Organic Material

[0049] The organic material in the active region **108** may include an electroluminescent polymer. The polymer may be a fluorescent emitter, a phosphorescent emitter or a combination of fluorescent and phosphorescent emitters. The polymer may include, for example, poly-phenylene vinylene, or poly-fluorene. The polymers are often engineered to substitute side chains onto the backbone to tune the color or to improve the processing of the polymers.

[0050] Alternative to a polymer emitter, a small molecule emitter comprising for example, organo-metallic chelates or conjugated dendrimers, may be used.

[0051] The organic material may be doped with phosphorescent material.

Electrical Coupling

[0052] The electrical coupling between the active region **108** and the anode **104** or cathode **106** may be a direct-contact coupling, or indirect coupling through more layers as discussed in detail below.

Power Supply

[0053] The power supply **114** may comprise a battery, an adapter, or may be part of a power grid. The OLED devices may be powered by AC or DC current.

Coupler

[0054] The OLED device in accordance with the claimed embodiments may comprise a coupler for coupling the OLED device with a mount or with one or more other OLED devices. The resulting OLED device is pre-manufactured in a modular fashion such that the OLED device may be a "plug-and-play" device. The OLED device can be readily "plugged in" to a system to reconfigure the color, appearance, brightness, or other properties of the system, or replace an existing OLED device in the system. The coupler can provide mechanical or electrical coupling. In addition, the coupler can provide a combination of electrical and mechanical coupling

[0055] In the embodiment shown in FIG. 1, the couplers **112** include those for coupling the OLED device **100** onto a mount **119**, and those that can be configured to couple to one or more other OLED devices.

[0056] In one embodiment as illustrated in FIG. 2A, a coupler **200a** may comprise a plurality of protrusions **202** configured to couple to a complementary indentation **204** in a corresponding coupler **200b**. The lateral dimension of the indentation **204** substantially matches the spacing of the protrusions **202**. The indentations may be holes or slots in the OLED device. The protrusions **202**, or the coupler **200b**, or both, may be slightly flexible. This can be achieved, for example, by making the couplers **200a** and **200b** using plastics. By plugging the protrusions **202** into the indentation **204**, a removable, yet stable coupling can be realized. The inter-

locking mechanism resembles that of the LEGO™ building blocks. The corresponding coupler **200b** may be part of the mount, or part of a second OLED device.

[0057] The protrusions **202** may have conductive and/or insulating patterns **203** disposed thereon, which may be electrically coupled to corresponding conductive regions (not shown) in the indentations **204** to make electrical connections when the couplers **200a**, **200b** are joined together. These conductive regions may be electrically connected to at least one of the anode or cathode or a power supply. The conductive regions of the couplers may be configured to provide an electrical connection between the OLED device electrodes and a power supply when corresponding couplers are joined.

[0058] In one embodiment as illustrated in FIG. 2B, a coupler **201a** may comprise one or more protrusions **206** configured to be coupled into corresponding indentations **208** in a corresponding coupler **201b**. The protrusions **206** may have conductive patterns **209** disposed thereon, which may be electrically coupled to corresponding conductive regions (not shown) in the indentations **208** to make electrical connections when the couplers **201a**, **201b** are joined together. Thus, in addition to making the mechanical coupling, the couplers also function as electrical coupling.

[0059] In one embodiment as illustrated in FIG. 2C, the protrusions **210** and indentations **212** for coupling may be positioned laterally and located on the edges of the OLED device **220**, rather than being oriented perpendicular to the plane of the OLED device. In this case, the OLED devices may be coupled to each other or to a mount at the device edges. When OLED devices are coupled to one another, conductive regions on coupler protrusions or indentations may electrically connect the device anodes to one another and the device cathodes to one another. At least one of the OLED devices would be coupled to a power supply, possibly through a mount. The other OLED devices may be coupled to the power supply through their connection to the chain of OLED devices. In this embodiment, the joined OLED devices would be commonly driven by the power supply.

[0060] FIG. 2C shows each OLED device as having two protrusions on two edges of the OLED device, and the remaining two edges having two indentations. Each edge may have a protrusion or indentation connecting to the OLED device anode, and a protrusion or indentation connecting to the OLED device cathode. The OLED device protrusions and indentations may be designed to facilitate simultaneous coupling of two adjacent edges of an OLED device to two other OLEDs, e.g., coupling the OLED device into a step. This may be achieved by flexible protrusions, for instance. While FIG. 2C shows two protrusions or indentations on an edge, other configurations are possible. For instance, one of four edges of a chip may comprise two protrusions, one connected to the OLED device anode and another to the OLED device cathode. The remaining three sides may have anode and cathode indentations. A network of devices can be made.

[0061] In the embodiments shown in FIGS. 1-2C, the couplers are attached to, or are part of, the OLED devices. As discussed below, in some other embodiments, couplers may be provided separately from the OLED devices and may be provided as part of a lighting kit for assembling OLED devices into a lighting system.

[0062] FIG. 2D shows examples of couplers **230**, **232** that are provided separately from the OLED devices **234**. The couplers may be configured to removably couple a plurality of OLED devices together in a lateral direction at the OLED

device edges. The couplers may provide electrical coupling, or mechanical coupling as in the coupler **230**. In a preferred embodiment, some of the couplers may provide a combination of electrical and mechanical coupling, as in the coupler **232**. Electrical coupling is made by establishing a connection of the OLED device electrodes **236** with conductive paths **238** of the coupler.

[0063] In a lighting system or kit comprising a plurality of couplers and OLED devices, at least one coupler is configured to be electrically coupled to a power supply. The coupler may directly couple to a power supply or indirectly couple to a power supply through, for examples, a mount, wires, or another OLED device. In some embodiments, the couplers comprise multiple conductive paths to supply various drive conditions to the OLED devices. In one example, the coupler may comprise four conductive paths. One conductive path may serve as an electrical connection to ground and the remaining three paths may deliver various drive conditions, such as various voltages **V1**, **V2**, and **V3**. The drive conditions may be selected to appropriately drive red, green, and blue OLED devices, respectively, for instance.

[0064] FIG. 2E shows an OLED device **240** that is compatible with couplers that comprise multiple conductive paths. The OLED device **240** has multiple electrodes **242**, **244**, **246**, **248**. Two of the electrodes **246** and **248** are used to make contact with the OLED device anode and cathode **250**, **252**. These electrodes could, for instance, connect with the voltage **V3** and ground conductive paths of the coupler. Additional electrodes may also be configured to help drive the OLED device if it comprises multiple emitting areas or layers that can be powered with different driving conditions.

[0065] In addition to electrodes **246** and **248**, the OLED device may also comprise additional electrodes **242** and **244** that connect to the coupler, but not to the active region of the OLED device. A large number of these additional electrodes could be provided if required by the application. These electrodes can be used to establish a low resistance electrical connection between couplers to which the OLED device is coupled. These electrodes are electrically isolated from the active region of the OLED device and are not used to power the device. These electrodes may, however, be used to supply power to other OLED devices that are connected via couplers and require different driving conditions. This provides a new mechanism to power an array of OLEDs requiring multiple driving conditions. This array of OLEDs can be connected only to each other, possibly through couplers, and not directly to the power supply.

Encapsulation

[0066] The OLED device may be already packaged in an encapsulation that protects the organic material of the OLED device from the ambient environment. The resulting OLED device may thus be a standalone device that can be readily installed in a system which does not necessarily provide oxygen and water vapor barriers.

[0067] Encapsulation may comprise barrier layers such as single or multi-layer barrier films such as Barix. Methods of coverage may include lamination, vapor deposition, or solution deposition. Furthermore, the encapsulation may comprise a sealant and a barrier structure such as a barrier film or housing. Desiccant materials may be contained within the encapsulation.

[0068] An encapsulation **302** of an OLED device **300** is illustrated in FIG. 3. The encapsulation **302** comprises a

housing **304** forming an enclosure **306** with the substrate **308**. A first sealant **310** is disposed between the housing **304** and the substrate **308**, and forms an oxygen and water vapor barrier for the active region **312**. The first sealant comprises, for example, mylar coated with metal, or epoxy based adhesives, etc.

[0069] The housing may have a first electrically conductive path **314** disposed in a first hermetic seal **316** through the housing **304**. The first electrically conductive path **314** may be electrically coupled to the cathode **318**.

[0070] The housing **304** may further have a second electrically conductive path **320** through the housing **304** via a second hermetic seal **324**. The second electrically conductive path **320** may be electrically coupled to the anode **322**. In this case, the housing **304** may comprise a non-conductive material.

[0071] In another embodiment, the housing **304** may be electrically conductive. For example, the housing **304** may comprise a metal, such as aluminum, or a conductive plastic. In this case, the first electrically conductive path **314** is electrically isolated from the housing **304**. Instead of using the second electrically conductive path **320** through the housing **304**, the anode **322** may be electrically coupled to the housing **304** through the first sealant **310** which in this case is conductive.

[0072] The electrically conductive housing **304** may thus form a common anode with neighboring OLED devices.

Housing

[0073] As shown in FIG. 4, the housing **400** has a contoured shape that allows the OLED device **402** to be arranged on a curved surface **404** with a plurality of neighboring OLED devices **406**, **408** without causing substantial interference between housings of neighboring OLED devices.

[0074] In one embodiment, the housing **400** has a slanted side wall **410** and a bottom wall **412**, and wherein a slant angle α of the slanted side wall **410** is selected such that, when the OLED device **402** is tightly arranged with a plurality of neighboring OLED devices **406**, **408** on the curved surface **404**, housings of neighboring OLED devices do not substantially interfere with each other. For example, when the slant angle α is about 60° , two neighboring OLED devices **402**, **406** may be arranged on a curved surface **404** with such a curvature that the OLED devices **402**, **406** form an inward angle of about 120° , while the neighboring sidewalls do not exert pressure on each other. In some embodiments, the slant angle α is in the range between about 30° and 90° .

[0075] The enclosure **414** formed between the housing **400** and the OLED device substrate **416** may be filled with an inert gas, such as argon, at a pressure higher than an atmospheric pressure. This further helps prevent oxygen and water vapor from entering the enclosure **414**. For example, the pressure may be between about 1.05 and 1.5 times the atmospheric pressure. The strength of the housing material and the active region material determines how high the pressure can be. In a preferred embodiment, the pressure is about 1.1 times the atmospheric pressure.

[0076] In the top plan view, the housing **400** has a shape configured to improve the fill factor, i.e., the ratio between the light emitting area to the total area, of the OLED device. The shape of the housing **400** in the top plan view may be a circle, an oval, or polygonal. In one exemplary embodiment, the housing may have a substantially hexagon shape in the top plan view as shown in FIG. 5. Thus, the OLED device **500** is

configured to be neighboring six other polygonal OLED devices to form a tightly arranged matrix.

[0077] The housing **400** may be coated with a color or labeled with a symbol indicative of a light emission color of the active region.

[0078] In some embodiments, the housing may comprise transparent plastic to allow light to pass through. The housing may also be made of glass. The glass housing may be manufactured in a certain shape to improve light out coupling.

Sealant in Encapsulation

[0079] As shown in FIG. 6A, the OLED device **600** has a first sealant **602** configured to form an oxygen and water vapor barrier for the active region **604**. The first sealant **602** is disposed between the housing **606** and a first side of the substrate **608**. The OLED device **600** may further include a second sealant **610** disposed on a second side of the substrate **608** opposite the first side. An edge portion **612** of the housing **606** may then be bent, forming a "roll crimp" over the second sealant **610**, thereby substantially enclosing an edge of the substrate **608**. The edge portion **612** of the housing **606** is in contact with the second sealant **610**, as illustrated in FIG. 6B, thereby forming the second seal that further prevents oxygen and water vapor from entering the enclosure.

[0080] A third sealant **614** may further be applied to seal off a gap between the substrate **608** and the bent portion (roll crimp) **616**. The multiple seals improve the sealing of the active region **604**, and thus increase its lifespan.

[0081] The packaging of the OLED devices may be performed before or after dicing of a large OLED substrate. In the case of before dicing, individual housings may be patterned corresponding to the individual active regions on the large OLED substrate, and are subsequently sealed, and the individual devices then diced. In the case that the individual OLED regions are already diced from the OLED substrate, both the dices and the housings are patterned correspondingly and then sealed together.

Continuous and Discrete Active Region

[0082] In the OLED device **700** illustrated in FIG. 7A, as viewed through the transparent substrate **701**, the active region **702** is a continuous region forming a single light emitter. Unlike inorganic LEDs which are typically point light sources, the OLED device **700** is an area light source. The active region can be as very large, e.g., on the order of one meter or larger. The size may be limited by manufacturing processes. The active region has a lateral dimension larger than about 0.1 cm. Preferably, the active region has a lateral dimension larger than about 0.5 centimeter. The active region preferably has an area larger than 25 mm^2 .

[0083] In another embodiment shown in FIG. 7B, the OLED device **704** has an active region **706** comprising a plurality of discrete light emitters **706a**, **706b**, **706c**, . . . , forming a plurality of pixels. The individual pixels may be collectively driven, e.g., through a common anode and a common cathode, and thus illuminate altogether. Alternatively, these pixels may be individually driven through their own anodes and cathodes. In the latter case, multiple electrical paths and hermetic seals may be needed through the housing and a controller may be used to individually or collectively control the pixels.

Emission Spectrum

[0084] The active region of the OLED device emits a relatively broad band spectrum. For example, as illustrated in FIG. 8, individual OLED devices may be configured to emit in the blue (B), green (G), or red (R) regime.

[0085] The FWHM of the individual spectrum may be larger than 50 nm. Preferably the FWHM is larger than about 100 nm, and may be even larger than about 200 nm in some cases. The broadband emission spectrum may be one selected from a white, a red, a green, a blue, a yellow, an orange, a cyan, or a magenta spectrum. By appropriately mixing different OLED devices, the output spectrum **800** may be visually substantially white.

[0086] The broadband emission spectrum **800** corresponds to a color rendering index (CRI) higher than about 60, and preferably higher than about 80, or even higher than about 90. In a preferred embodiment, the broadband emission spectrum corresponds to a CRI of about 100.

[0087] Advantageously, the broadband spectra of individual OLED devices are mixed to form the output spectrum **800** which may be very close to naturally white light to human eyes. This is in contrast to conventional lighting systems comprising inorganic LED devices, the spectra of which have a relative narrow band, e.g., on the order of about 10 nm. The resulting mixed light may not be naturally white even when the CRI is high.

[0088] The active region of the OLED device may be substantially transparent. The anode may comprise a transparent conductor, for example, ITO. The cathode may comprise one of a metal or a metal alloy, such as aluminum-copper. In some embodiments, the cathode may also comprise a transparent conductor. When mostly transparent layers are used, a plurality of OLED devices may be vertically stacked without blocking light emission from individual devices. In addition, an OLED device may include a plurality of vertically-stacked transparent OLED chips, which are not standalone devices as they may not have their own encapsulations, but may have their own substrates and electrodes and can be individually controlled.

Layers

[0089] The early relatively simple devices were not particularly efficient; they emitted few photons relative to the number of charges injected. As the OLED technology evolved, better understanding of the electrode/polymer interfaces has led to the development of new, more advanced and efficient devices. In particular, hole injection and/or hole transport materials forming a layer between one electrode and the electroluminescent material can improve the efficiency of the device. Thus, hole injection layers (HIL) or hole transport layers (HTL) are often used in OLED structures.

[0090] Additional layer and materials technology pertaining to organic electronic devices, including HIL and HTL technology, is described in, for example, U.S. application Ser. No. 11/826,394 filed Jul. 13, 2007 (Sulfonation of conducting polymers and OLED, photovoltaic, and ESD devices), U.S. application Ser. No. 11/496,024 filed Jul. 31, 2006 (Latent Doping of Conducting Polymers), U.S. application Ser. No. 12/113,058 filed Apr. 30, 2008 (Solvent System for Conjugated Polymers), U.S. application Ser. No. 11/350,271 filed Feb. 9, 2006 (Hole Injection Layer Compositions), U.S. application Ser. No. 12/153,181 filed May 14, 2008 (Aryl-substituted conjugated polymers related applications), U.S.

provisional application No. 60/960,851 filed Oct. 16, 2007 (Organic Electrodes and Electronic Devices), U.S. provisional application No. 61/029,255 filed Feb. 15, 2008 (Novel Compositions, Methods, and Polymers), U.S. provisional application No. 61/032,905 filed Feb. 29, 2008 (Planarizing Agents and Devices), and U.S. provisional application No. 61/043,654 filed May 13, 2008 (Hole Injection Layer Compositions and Photovoltaic Devices), and are incorporated herein by reference in their entirety.

[0091] More layers may be included in an OLED device to improve the light emitting efficiency. For example, as illustrated in FIG. 9, an OLED device **900** may comprise an anode **902** which includes an ITO layer disposed on glass or polyethylene terephthalate (PET), a hole injection layer **904**, an active layer **906**, an electron transport layer **908**, and a cathode **910**. The cathode **910** may comprise Ca, Al, or Ba.

[0092] The active region **906** may comprise an electroluminescent polymer disposed as at least one emissive layer, which may be formed by a solution-based process such as ink jet printing, or vapor deposition processes.

[0093] The hole injection layer **904** may comprise an inherently conductive polymer. For example, the hole injection layer **904** may comprise a substituted poly-thiophene, a regio-regular substituted poly-thiophene, or a regio-regular substituted poly-3-thiophene. At least one planarizing agent may be included with the polythiophene. The planarizing agent may be selected from, for example, polyvinyl alcohol (PVOH), or derivatives thereof. The planarizing agent helps planarizing the interface between layers thereby facilitating the transfer of holes across the interface. The planarizing agent can also help to reduce the optical absorbance, thereby increasing the light output efficiency.

[0094] The hole injection layer **904** may also be formed by a solution based process, or by vapor deposition processes. For example, the hole injection layer **904** may be formed by spin casting, drop casting, dip-coating, spray-coating, or by printing methods such as ink jet printing, off-set printing, or by a transfer process. For example, ink jet printing is described in U.S. Pat. No. 6,682,175 to Otsuka, and in Hebner et al., *Applied Physics Letters*, 72, no. 5, Feb. 2, 1998, pages 519-521, the disclosures of which are hereby incorporated by reference in their entirety.

[0095] The hole injection layer **904** can be provided that is about 10 nm to about 50 μm in thickness with typical thickness ranging from about 50 nm to about 1 μm . In another embodiment, thickness can be about 10 nm to about 500 nm, and more particularly, about 10 nm to about 100 nm.

[0096] Similarly, the electron transport layer **908** may be formed by a solution-based process, or by vapor deposition processes.

[0097] Other layers, such as an electron injecting layer, a hole blocking layer, or an electron blocking layer may also be included. The resulting OLED device would comprise an anode, a hole injection layer, a hole transport layer, an electron blocking layer, an active region such as one or more light emitting layers, a hole blocking layer, an electron transport layer, an electron injection layer, and a cathode. The hole transport layer and the electron transport layer facilitate transportation of electrons and holes, respectively, into the active region, while the electron and hole blocking layers prevent electrons or holes leaving the active region.

[0098] Examples for materials used for the different layers include:

- [0099] 1) Hole injection layer: PEDOT (poly(3,4-ethylenedioxythiophene)):PSS (polystyrenesulfonic acid), Plexcore OC, LG101 (Hexaazatriphenylene hexanitrile), MeO-TPD ([1,1'-Biphenyl]-4,4'-diamine, N4,N4'-bis(4-methoxyphenyl)-N4,N4'-diphenyl-benzidine):F4TCNQ (N4,N4'-diphenyl-benzidine);
- [0100] 2) Electron injection layer: Li (lithium), Ca (Calcium), Ba (Barium), LiF (Lithium Fluoride), CsCO₃ (Cesium Carbonate), Ca(acac) (calcium acetylacetonate), Li:BPhen (Lithium:Bathophenanthroline(4,7-Diphenyl-1,10-phenanthroline)), Cs:BPhen (Cesium: Bathophenanthroline(4,7-Diphenyl-1,10-phenanthroline));
- [0101] 3) Hole transport layer: TPD, NPB (1,4-bis(1-naphthylphenylamino)biphenyl), Polymeric versions of TPD or other benzidines, PFO (poly(fluorene-oxadiazole)), TFB (poly(2,7-(9,9-di-n-octylfluorene)-(1,4-phenylene-(4-secbutylphenyl)imino)-1,4-phenylene)), PPV (poly(1,4-phenylene vinylene));
- [0102] 4) Electron transport layer: Alq₃ (Tris-(8-hydroxyquinolino)aluminum), Lithium quinoline, OXD-7 (2,2'-(1,3-Phenylene)bis[5-[4-(1,1-dimethylethyl)phenyl]]-1,3,4-Oxadiazole), TAZ (3,5-Bis(4-tert-butylphenyl)-4-phenyl-triazole);
- [0103] 5) Hole blocking layer: BCP (2,9-dimethyl-4,7-diphenyl-1,10-phenanthroline), BPhen, OXD-7, TAZ;
- [0104] 6) Electron blocking layer: TCTA (4,4',4''-Tris(carbazol-9-yl)-triphenylamine), Spiro-TAD (2,2',7,7'-Tetrakis(n,n-diphenylamino)-9,9'-spirobifluorene); and
- [0105] 7) Light emitting layer: Polyfluorene family, PPV family, co-deposited small molecule films such as Ir(ppy)₃ (Tris[2-(2-pyridinyl)phenyl-C,N]-iridium (III)) in CBP (4,4'-Bis(carbazol-9-yl)-biphenyl).

Stacked Light Emitting Layers

[0106] In an embodiment shown in FIG. 10, an OLED device 1000 has an active region comprising a plurality of vertically-stacked light emitting layers 1006a, 1006b, 1006c. At least two of the light emitting layers are configured to emit light of different colors. The plurality of vertically-stacked light emitting layers 1006a, 1006b, 1006c may be interlaced with substantially transparent non-emitting layers 1008a, 1008b, 1008c, 1008d.

[0107] The substantially transparent non-emitting layers 1008b, 1008c may be electrodes for one of the light emitting layers 1006b so that the light emitting layers 1006b may be independently controlled using a power supply 1020 that is different from the power supply 1030 for the OLED device 1000. Those of ordinary skill in the art will recognize that instead of using different power supplies 1020, 1030, a single power supply can be used that is coupled to a controller, and the controller individually addresses and controls the different light emitting layers. In the configuration shown in FIG. 10, an electrical path may be configured from the anode 1002 to the cathode 1010 while bypassing the electrodes 1008b, 1008c and the light emitting layer 1006b.

[0108] The cathode 1010 may be disposed on a transparent substrate. The cathode 1010 and the anode 1002 may also be substantially transparent such that the OLED device 1000 is configured to emit light in both the cathode and the anode directions. A transparent material selected from a conductive

oxide, a metal thin film, or an organic thin film may be used for the transparent cathode or anode.

[0109] In some embodiments, at least one of the anode 1002 or the cathode 1010 comprises a reflective material, and the OLED device 1000 is configured to be an edge emitting OLED device. The reflective layers, which may be coated layers, or layers with selected refractive indices to cause a total internal reflection, may form a waveguide for the emitted light. The edge emitting OLED device can use non-transparent layers without blocking light in a stacked configuration.

[0110] The lateral dimension d of the active region as shown is larger than about 0.5 centimeter. Thus, this OLED device 1000 advantageously is an area light source, unlike conventional inorganic LED devices which are typically point light sources. The lateral dimension d can be as large as possible, but may be limited by manufacturing processes. Typically d is smaller than about 1 meter. Preferably, d is less than a characteristic distance for charge transport, e.g., the distance charges can travel, in the anode 1002. When the anode 1002 comprises ITO, d is preferably less than about 10 cm.

[0111] Other stacked configurations of OLED devices are possible. As illustrated in FIG. 11, an OLED device 1100 comprises a substrate 1101, a first anode 1102, an HIL 1104, a first light emitting layer 1106, a first cathode 1108, a second anode 1110, a second light emitting layer 1112, an electron transport layer 1114, and a second cathode 1116. The first light emitting layer 1106 is electrically coupled to the first anode 1102 and the first cathode 1108. The second light emitting layer 1112 is electrically coupled to the second anode 1110 and the second cathode 1116. The first and second emitting layers 1106, 1112 may be electrically coupled in series to a single power supply. Alternatively, the first and second emitting layers 1106, 1112 may be individually controlled and/or addressed.

[0112] An encapsulation 1118 may be used to isolate the first and second light emitting layers 1106, 1112 from the ambient environment. One or more couplers 1120 may be configured to electrically couple at least one of the first anode, the second anode, the first cathode, or the second cathode to a power supply. Each of the first or second light emitting layers 1106, 1112 comprises an organic material and is configured to emit a broadband emission spectrum with a FWHM larger than about 50 nm. The first and second light emitting layers 1106, 1112 may be of the same color, or have different colors.

Light Out-Coupling

[0113] In addition to including layers such as HIL to improve the light emitting efficiency, the OLED device may have an improved light emitting efficiency by improving the light out-coupling efficiency by engineering the optics. In some embodiments, the OLED device includes a light coupling layer configured to improve light out-coupling. For example, as illustrated in FIG. 12A, the OLED device 1200 has a substrate 1202 with a lens-shaped surface. As shown in FIG. 12B, the OLED device 1204 has a substrate 1206 with a patterned surface. The patterned surface forms a grating that improves the light out-coupling efficiency and directability. Alternatively, the light coupling layer may comprise a plurality of microlenses, a photonic crystal, a roughened transparent surface, or a low refractive index layer. The low refractive index layer may comprise, for example, an aerogel. The low refractive index layer may reduce the internal reflection in the vertically emitting configuration. A combination of light out-

coupling techniques may be used. For example, the substrate may have a patterned surface such as a grid etched in a glass substrate that is used to refract trapped light through the glass and into a layer of micro-lenses.

[0114] In some embodiments, the light out-coupling layer is also configured to convert the spectrum emitted by the active region to another spectrum of a longer wavelength. For example, the light coupling layer may comprise a phosphor layer, or a quantum-dot-based film. The phosphor layer or the quantum-dot-based film can be configured for down-converting photons of higher energy to lower energy.

OLED Lighting Kit

[0115] The OLED structure illustrated in FIG. 1, as well as other basic OLED structures, can be applied to a modular design of OLED devices for lighting. In particular, a plurality of pre-manufactured modular OLED devices may be provided, and the individual modular OLED devices can be selected and “plugged” into a system mount, thereby forming a configurable lighting system. The system can have desired optical properties, such as the color, by selecting an appropriate set of OLED devices to couple to the mount.

[0116] The pre-manufactured OLED devices such as that illustrated in FIG. 1 can be provided in a lighting kit. The lighting kit can include at least two types of pre-manufactured, modular OLED devices of different colors, each OLED device comprising a substrate, an anode, a cathode, and an active region comprising an organic material.

[0117] In addition to different colors, OLED devices with different sizes, ranging from 0.1 cm to 1 m, and different shapes such as circular or polygonal, may be provided. The OLED devices may already have couplers attached thereto, and thus are “plug and play” devices.

[0118] The lighting kit may further comprise a power supply, a mount for receiving at least one of the plurality of OLED devices, and a plurality of conductive couplers. The conductive couplers may be attached to the OLED devices already, or may be provided separately. Each of the plurality of conductive couplers has at least one conductive surface area and at least one insulating surface area at predetermined locations for electrically coupling one of the OLED devices with another OLED device, or with the mount.

[0119] The lighting kit may further comprise a homogenizer to reduce the pixilated appearance of an OLED array.

[0120] The lighting kit can further include instructional materials, including how to assemble and use the components, and the component specifications, as described throughout this disclosure.

OLED Device Assembled from the Lighting Kit

[0121] A customer, such as a consumer electronics manufacturer or a consumer, may select a subset of OLED devices from the lighting kit, and assemble a lighting or signage apparatus with appropriate selection of OLED devices having different colors and brightness.

[0122] For example, in FIG. 13, a stacked OLED configuration is shown, where a plurality of OLED devices 1302, 1304, 1306 are stacked vertically. One or more electrodes 1308 may be arranged on the side, and the individual OLEDs may have transparent substrates such as in transparent glass-on-glass configuration. The stacked OLED structure increases the total light output per unit area, while the individual OLED devices may be driven at a relatively low current, thereby increasing their lifespan.

[0123] Alternative to using the glass-on-glass structure, light may be coupled out from the edges of the stack, for example, using gratings and waveguides.

Vertical Coupling of Stacked OLED Devices

[0124] A method of coupling an OLED device vertically with another OLED device, or with a mount, is illustrated in FIG. 14A. The OLED device 1402 and the mount 1404 have pre-fabricated via holes 1406, in which elongated conductors 1408 may be fit in. The via holes 1406 may be etched or machined, depending on the substrate material of the OLED device 1402 or the mount 1404.

[0125] The elongated conductors 1408 have patterned outer surface areas with insulating regions 1410 and conductive regions at desired locations such that, when fitted into the via holes 1406, proper electrical paths and insulations among the vertical layers may be formed. The elongated conductors 1408 may be fit into the via holes 1406 by “stapling,” or by threaded engaging. The elongated conductor 1408 may be flexible to accommodate a flexible system. The elongated conductor is configured to both mechanically and electrically couple one of the OLED devices 1402 with another one of the OLED devices or with the mount 1404.

[0126] In the mount 1404 shown in FIG. 14A, two conductive layers 1412 and 1414 are included. When the elongated conductor 1408 is coupled to the mount 1404 and the OLED device 1402, the insulating region 1410 comes into contact with the second conductive layer 1414. Accordingly, an electrical connection is established between the first conductive layer 1412 and the OLED device 1402 through the elongated conductor 1408. By prearranging the locations of the insulating regions and the conductive layers, complex electrical connections may be established.

[0127] In another example shown in FIG. 14B, two elongated conductors are included each having insulating regions located at different locations. These locations may correspond to the depth of the two conductive layers. As shown, once both elongated conductors are coupled to the OLED device and the mount, two electrodes of the OLED device may be coupled to the first and second conductive layers, respectively.

[0128] Further, in an embodiment shown in FIG. 14C, an integrated connector 1430 may be used. The integrated connector 1430 has a substantially “U” shape with two “arms” and resembles a staple. Insulating regions are disposed at different locations of the integrated connector 1430. Those of ordinary skill in the art will recognize that connectors of other shapes with more “arms” are possible.

[0129] As shown in FIG. 14D, an example OLED device 1440 has one or more contact pads 1442. The OLED device 1440 can be coupled to a mount, or to another OLED device 1444, using elongated conductors 1446 that may be “stapled” through the contact pads 1442.

[0130] The modular OLED devices, which are pre-manufactured and may be already packaged, may be “plugged in” or “dropped in” to a mount and arranged in a pattern. Advantageously as a result of the modular design, the individual OLED devices may be selected from a lighting kit comprising devices with different color characteristics, sizes, and shapes.

[0131] In one embodiment, the modular OLED devices are selected and dropped in on the mount in a ratio based on their expected lifespan. For example, a two-to-one ratio between the number of blue OLEDs and the number of red OLEDs

may be predetermined based on that the lifespan of the blue OLED is about half that of the red OLED.

[0132] In one example, more blue OLED devices, which typically have shorter life spans, are included in the lighting system, as compared with red or green OLED devices. For example, for every red or green OLED, two (2) blue OLED devices may be included. The two blue OLED devices may be alternately activated as controlled by a controller.

[0133] In a “low cost” approach, all the OLED devices may be simply driven by a same voltage and the blue OLEDs may be configured to have higher resistance and thus lower current. This also would improve the lifespan of the blue OLED devices, while the increased number of these blue OLED devices compensates for the lower activation levels to realize the desired luminance and color characteristics.

[0134] During the wearing/aging of the lighting system, the color and other optical characteristics are thus effectively controlled by the selection of the OLED devices.

An Exemplary Embodiment

[0135] A prophetic example of a pre-manufactured modular OLED device **1500** is illustrated in FIG. **15**. The geometrical shapes and sizes are exaggerated for clarity, and are not drawn to scale. The OLED device **1500** as shown has a lateral dimension of about 1 cm, and has a hexagonal shape in a top plan view as in FIG. **5**. When provided in a lighting kit, multiple OLED devices are provided with different sizes, colors, and shapes. The glass substrate **1502** is about 1 mm thick. Disposed on the glass substrate **1502** is a layer of ITO **1504** as the anode, which is about 100 nm thick. A hole injection layer **1506**, comprising an inherently conductive polymer, is adjacent the anode and is about 200 nm thick. The active region **1508** comprises poly-phenylene vinylene, and is about 300 nm thick.

[0136] A condition layer **1510** comprising LiF, which may be only a few angstroms thick, is disposed between the active region **1508** and the cathode **1512** to improve the coupling between the active region **1508** and the cathode **1512**. The cathode **1512** comprises an aluminum layer with a thickness of about 100 nm.

[0137] The above layers are enclosed in the housing **1514**. The cathode **1512** is electrically coupled, through a hermetic seal **1516** on the housing **1514**, to a first coupler **1518**. The housing **1514** in this embodiment is composed of aluminum, and is electrically coupled to the anode **1504**. A second coupler **1520** is attached to the housing **1514**, and thus is electrically coupled to the anode **1504**. The OLED device **1500** can thus be readily plugged into corresponding couplers (indentations) on a mount or another OLED device.

[0138] In this prophetic example wherein the housing **1514** is composed of aluminum, the housing **1514** is shaped from aluminum flatstock to have a thickness, composition and temper to permit single or multi-stage stamping or drawing that results in a “pan” of the desired geometric configuration to accommodate the installation of the OLED devices. The configuration of the pan is made to conform to the OLED device **1500** in such a way that the installed device rests on a lip **1523** formed into the sidewall **1521** of the pan and is of uniform dimension around the circumference of the pan. This lip **1523** serves as the first surface to which sealant/adhesive **1522** is applied to affect the hermetic encapsulation of the OLED device. The described sidewall **1521** shall be of a height to extend above the installed OLED device by not less

than the thickness of the OLED substrate to four (4) times the thickness of the OLED substrate.

[0139] To the installed and sealed OLED device a continuous bead of a second sealant **1524** of the same or of a different composition than the first sealant **1522** is applied to the external surface of the OLED device **1500** in proximity to the edge of the device and completely around the circumference of the OLED device **1500**. After application of the second sealant **1524**, the sidewall **1521** is “rolled” or “ironed” over the bead of second sealant **1524** to form a “lock” **1526** whereby the second sealant **1524** is captured beneath the “lock” **1526** and thereby retains the OLED layers in the “pan.” A third sealant **1528** further seals the lock **1526**. The objective of such a configuration and material combination is to form a torturous path to resist the migration of water and oxygen to the inside of the OLED device enclosure.

[0140] As shown the aluminum housing (“pan”) **1514** is further modified to include one or two hermetically sealed electrical contacts **1518**, **1520** on the bottom side of the housing **1514** such that the required electrical power for the OLED device can be delivered without jeopardizing the hermetic seals. In the case where there is only one electrical contact, the contact may carry the positive charge (+) to the active region **1508**, and the “pan” itself provides the negative (-) path through contact with other “pans” and eventually to the power supply. Alternatively, the “pan” may be used as a common anode while the contact **1518** through the hermetic seal **1516** may be coupled to the cathode **1512** as shown in FIG. **15**.

Further Embodiments

[0141] Additional embodiments are provided in U.S. priority provisional application 61/090,150 filed Aug. 19, 2009 which is hereby incorporated by reference in its entirety.

[0142] In one aspect, an OLED device is provided. The OLED device includes a substrate, an anode, a cathode, an active region comprising an organic material, wherein the active region is electrically coupled to the anode and the cathode and is configured to emit a broadband emission spectrum with a FWHM larger than about 50 nm, at least one coupler configured to electrically couple at least one of the anode or the cathode to a power supply, and an encapsulation that isolates the active region from an ambient environment.

[0143] In another aspect, an OLED device is provided, which includes a substrate, an anode, a cathode, and an active region comprising an organic material, wherein the active region is electrically coupled to the anode and the cathode and is configured to emit a broadband emission spectrum with a FWHM larger than about 50 nm, at least one coupler configured to electrically couple at least one of the anode or the cathode to a power supply, and an encapsulation that isolates the active region from an ambient environment, wherein the active region comprises a plurality of vertically-stacked light emitting layers.

[0144] The active region can include a plurality of vertically-stacked light emitting layers. The light emitting layers may be interlaced with multiple electrodes such that the light emitting layers may be individually addressed and controlled.

[0145] In another aspect, an OLED device is provided, which includes a substrate, a first anode, a hole injection layer adjacent the first anode, a first light emitting layer, a first cathode, a second anode, a second light emitting layer, an electron transport layer, a second cathode, at least one coupler configured to electrically couple at least one of the first anode, the second anode, the first cathode, or the second cathode to a

power supply, and an encapsulation that isolates the first and second light emitting layers from an ambient environment, wherein each of the first or second light emitting layers comprises an organic material and is configured to emit a broadband emission spectrum with a FWHM larger than about 50 nm, and wherein the first and second light emitting layers are electrically coupled to their respective anodes and cathodes.

[0146] In another aspect, a kit of pre-manufactured modular OLED devices is provided. The OLED devices include at least two types of OLED devices of different colors, each OLED device including a substrate, an anode, a cathode, and an active region including an organic material, wherein the active region is electrically coupled to the anode and the cathode and is configured to emit a broadband emission spectrum with a FWHM larger than about 50 nm, at least one coupler configured to electrically couple at least one of the anode or the cathode to a power supply, and an encapsulation that isolates the active region from an ambient environment.

[0147] In another aspect, a method of manufacturing an OLED device is provided. The method includes providing a substrate, an anode, a cathode, and an active region comprising an organic material, and a housing, wherein the active region is electrically coupled to the anode and the cathode and is configured to emit a broadband emission spectrum with a FWHM larger than about 50 nm, and assembling the substrate, the anode, the cathode, the active region and the housing to form the OLED device.

[0148] In another aspect, an OLED device is provided, which includes a substrate, an anode, a cathode, an active region comprising an organic material, wherein the active region is electrically coupled to the anode and the cathode, at least one coupler, and an encapsulation that isolates the active region from an ambient environment.

[0149] In another aspect, a lighting system is provided. The lighting system includes a plurality of OLED devices, wherein each of the OLED devices includes a substrate, an anode, a cathode, an active region comprising an organic material, wherein the active region is electrically coupled to the anode and the cathode, at least one coupler configured to electrically couple at least one of the anode or the cathode to a power supply, and an encapsulation that isolates the active region from an ambient environment.

[0150] At least one advantage from at least one embodiment is that the OLED device is a “plug and play” device and can be readily placed into a system and/or replace an existing device. The encapsulation and the coupler allow the OLED device to be a standalone device.

[0151] At least another advantage from at least one embodiment is the large area light emitting source as a result of using organic materials. The ease of manufacturing and the tunable color with the desirable visual effect are provided by the organic material.

[0152] In at least some of the embodiments, an OLED device is provided. The OLED device comprises a substrate, an anode, a cathode, an active region comprising an organic material, wherein the active region is electrically coupled to the anode and the cathode and is configured to emit a broadband emission spectrum with a FWHM larger than about 50 nm, at least one coupler configured to electrically couple at least one of the anode or the cathode to a power supply, and an encapsulation that isolates the active region from an ambient environment.

[0153] In one aspect, the OLED device coupler is configured to electrically couple at least one of the anode or the cathode with the power supply via a mount.

[0154] In another aspect, the OLED device coupler is configured to electrically couple at least one of the anode or the cathode with the power supply via a second OLED device.

[0155] In one aspect, the OLED device coupler may be configured to mechanically couple the OLED device with a mount or with a second OLED device.

[0156] In one aspect, the OLED device coupler comprises a protrusion configured to be snapped into an indentation on a mount or a second OLED device.

[0157] In another aspect, the OLED device coupler comprises an indentation for a protrusion of a mount or a second device to snap therein.

[0158] In one embodiment, the OLED device encapsulation comprises a housing forming an enclosure with the substrate and a first sealant configured to form an oxygen and water vapor barrier for the active region.

[0159] In another aspect, the OLED device encapsulation comprises a housing forming an enclosure with the substrate and a first sealant configured to form an oxygen and water vapor barrier for the active region wherein the housing comprises a first electrically conductive path disposed in a first hermetic seal through the housing, and this first electrically conductive path is electrically coupled to the cathode.

[0160] In one embodiment, the OLED device encapsulation comprises a housing forming an enclosure with the substrate and a first sealant configured to form an oxygen and water vapor barrier for the active region, wherein the housing has a first electrically conductive path in a first hermetic seal through the housing, and wherein the first electrically conductive path is electrically coupled to the cathode, wherein the housing further has a second electrically conductive path through the housing, and wherein the second electrically conductive path is electrically coupled to the anode.

[0161] In another aspect, the OLED device encapsulation comprises a housing forming an enclosure with the substrate and a first sealant configured to form an oxygen and water vapor barrier for the active region, wherein the housing has a first electrically conductive path in a first hermetic seal through the housing, and wherein the first electrically conductive path is electrically coupled to the cathode, wherein the housing further has a second electrically conductive path through the housing, and wherein the second electrically conductive path is electrically coupled to the anode, wherein the second electrically conductive path is through a second hermetic seal.

[0162] In another embodiment, the OLED device encapsulation comprises a housing forming an enclosure with the substrate and a first sealant configured to form an oxygen and water vapor barrier for the active region, wherein the housing is electrically conductive, and wherein the first electrically conductive path is electrically isolated from the housing, and further wherein the anode is electrically coupled to the housing.

[0163] In another aspect, the OLED device encapsulation comprises a housing forming an enclosure with the substrate and a first sealant configured to form an oxygen and water vapor barrier for the active region, wherein the housing is electrically conductive, and wherein the first electrically conductive path is electrically isolated from the housing, and further wherein the anode is electrically coupled to the hous-

ing, wherein the electrically conductive housing forms a common anode with neighboring OLED devices.

[0164] In another aspect, the OLED device encapsulation comprises a housing forming an enclosure with the substrate and a first sealant configured to form an oxygen and water vapor barrier for the active region, wherein the housing is electrically conductive, and wherein the first electrically conductive path is electrically isolated from the housing, and further wherein the anode is electrically coupled to the housing, wherein the housing has a contoured shape that allows the OLED device to be arranged on a curved surface with a plurality of neighboring OLED devices without causing substantial interference between housings of neighboring OLED devices.

[0165] In another aspect, the OLED device encapsulation comprises a housing forming an enclosure with the substrate and a first sealant configured to form an oxygen and water vapor barrier for the active region, wherein the housing is electrically conductive, and wherein the first electrically conductive path is electrically isolated from the housing, and further wherein the anode is electrically coupled to the housing, wherein the housing has a contoured shape that allows the OLED device to be arranged on a curved surface with a plurality of neighboring OLED devices without causing substantial interference between housings of neighboring OLED devices, wherein the housing has a slanted side wall and a bottom wall, and wherein a slant angle of the slanted side wall is selected such that, when the OLED device is tightly arranged with a plurality of neighboring OLED devices on a curved surface, housings of neighboring OLED devices do not substantially interfere with each other.

[0166] In one aspect, the OLED device encapsulation comprises a substantially polygonal housing forming an enclosure with the substrate.

[0167] In another aspect, the OLED device encapsulation comprises a substantially hexagonal housing forming an enclosure with the substrate.

[0168] In one aspect, the OLED device encapsulation comprises a housing forming an enclosure with the substrate and a first sealant configured to form an oxygen and water vapor barrier for the active region, wherein the enclosure is filled with an inert gas at a pressure equal to or higher than an atmospheric pressure.

[0169] In one aspect, the OLED device encapsulation comprises a housing forming an enclosure with the substrate and a first sealant configured to form an oxygen and water vapor barrier for the active region, wherein the enclosure is filled with an inert gas at a pressure higher than an atmospheric pressure, wherein the pressure is between about 1.05 and 1.5 times the atmospheric pressure.

[0170] In one aspect, the OLED device encapsulation comprises a housing forming an enclosure with the substrate and a first sealant configured to form an oxygen and water vapor barrier for the active region, wherein the enclosure is filled with an inert gas at a pressure higher than an atmospheric pressure, wherein the pressure is about 1.1 times the atmospheric pressure.

[0171] The encapsulation can a housing forming an enclosure with the substrate; and a first sealant configured to form an oxygen and water vapor barrier for the active region, wherein the housing has a substantially hexagon shape such that the OLED device is configured to be neighboring six other polygonal OLED devices to form a matrix.

[0172] In one aspect, the OLED device encapsulation comprises a housing forming an enclosure with the substrate and a first sealant configured to form an oxygen and water vapor barrier for the active region, wherein the housing is coated with a color or is labeled with a symbol indicative of a light emission color of the active region.

[0173] In one aspect, the OLED device encapsulation comprises a housing forming an enclosure with the substrate and a first sealant configured to form an oxygen and water vapor barrier for the active region, wherein the housing comprises one or more of a metal, a conductive plastic, a non-conductive material, a transparent plastic, or a glass with a predetermined shape.

[0174] In one aspect, the OLED device encapsulation comprises a housing forming an enclosure with the substrate; and a first sealant configured to form an oxygen and water vapor barrier for the active region, wherein the housing is composed of aluminum.

[0175] In one aspect, the OLED device encapsulation comprises a housing forming an enclosure with the substrate; and a first sealant configured to form an oxygen and water vapor barrier for the active region, wherein the first sealant is disposed between the housing and a first side of the substrate, the OLED device further comprising a second sealant disposed on a second side of the substrate, and further wherein an edge portion of the housing substantially encloses an edge of the substrate and is in contact with the second sealant.

[0176] In one aspect, the OLED device encapsulation comprises a housing forming an enclosure with the substrate, a first sealant configured to form an oxygen and water vapor barrier for the active region, wherein the first sealant is disposed between the housing and a first side of the substrate, the OLED device further comprising a second sealant disposed on a second side of the substrate, and further wherein an edge portion of the housing substantially encloses an edge of the substrate and is in contact with the second sealant, a third sealant for sealing a gap between the edge portion of the housing and the second side of the substrate.

[0177] In one aspect, the OLED device active region is a continuous region forming a single light emitter.

[0178] In one aspect, the OLED device active region comprises a plurality of light emitters.

[0179] In one aspect, the OLED device FWHM is larger than about 100 nm.

[0180] In one aspect, the OLED device is larger than about 200 nm.

[0181] In one aspect, the OLED device broadband emission spectrum is one selected from a white, a red, a green, a blue, a yellow, a orange, a cyan, or a magenta spectrum.

[0182] In one aspect, the OLED device broadband emission spectrum corresponds to a CRI higher than about 60.

[0183] In one aspect, the OLED device broadband emission spectrum corresponds to a CRI higher than about 80.

[0184] In one aspect, the OLED device broadband emission spectrum corresponds to a CRI higher than about 90.

[0185] In one aspect, the OLED device broadband emission spectrum corresponds to a CRI of about 100.

[0186] In one aspect, the OLED device active region is substantially transparent.

[0187] In one aspect, the OLED device anode comprises a transparent conductor.

[0188] In one aspect, the OLED device anode comprises ITO.

[0189] In one aspect, the OLED device cathode comprises a transparent conductor.

[0190] In one aspect, the OLED device cathode comprises at least one of an organic or an inorganic material.

[0191] In one aspect, the OLED device cathode comprises one of aluminum or copper.

[0192] In one aspect, the OLED device further comprises at least one hole injection layer.

[0193] In one aspect, the OLED device further comprises at least one hole injection layer and at least one electron transport layer.

[0194] In one aspect, the OLED device active region comprises one or a fluorescent emitter, or a phosphorescent emitter.

[0195] In one aspect, the OLED device active region comprises one or a polymer emitter, or a small molecule emitter.

[0196] In one aspect, the OLED device active region comprises at least one emissive layer, and wherein the at least one emissive layer is formed by one or a solution based process, or vapor deposition processes.

[0197] In one aspect, the OLED device further comprises at least one hole injection layer, wherein the at least one hole injection layer comprises an inherently conductive polymer.

[0198] In one aspect, the OLED device further comprises at least one hole injection layer, wherein the at least one hole injection layer comprises one or more of a substituted poly-thiophene, a regio-regular substituted poly-thiophene, regio-regular substituted poly-3-thiophene, or a regio-regular substituted poly-thiophene and at least one planarizing agent.

[0199] In one aspect, the OLED device further comprises at least one hole injection layer, wherein the at least one hole injection layer is formed by one of a solution based process, or vapor deposition processes.

[0200] In one aspect, the OLED device further comprises at least one electron transport layer, wherein the at least one electron transport layer is formed by one or a solution based process, or vapor deposition processes.

[0201] In one aspect, the OLED device further comprises a light coupling layer configured to improve light out-coupling.

[0202] In one aspect, the OLED device further comprises a light coupling layer configured to improve light out-coupling, wherein the light coupling layer has a lens shaped surface.

[0203] In one aspect, the OLED device further comprises a light coupling layer configured to improve light out-coupling, wherein the light coupling layer has a patterned surface forming a grating.

[0204] In one aspect, the OLED device further comprises a light coupling layer configured to improve light out-coupling, wherein the light coupling layer comprises a plurality of microlenses.

[0205] In one aspect, the OLED device further comprises a light coupling layer configured to improve light out-coupling, wherein the light coupling layer comprises a phosphor layer.

[0206] In one aspect, the OLED device further comprises a light coupling layer configured to improve light out-coupling, wherein the light coupling layer is also configured to convert the spectrum to another spectrum of longer wavelength.

[0207] In one aspect, the OLED device further comprises a light coupling layer configured to improve light out-coupling, wherein the light coupling layer comprises a quantum-dot-based film configured to convert the spectrum to another spectrum of longer wavelength.

[0208] In one aspect, the OLED device further comprises a light coupling layer configured to improve light out-coupling, wherein the light coupling layer comprises a photonic lattice.

[0209] In one aspect, the OLED device further comprises a light coupling layer configured to improve light out-coupling, wherein the light coupling layer has a roughened transparent surface.

[0210] In one aspect, the OLED device further comprises a light coupling layer configured to improve light out-coupling, wherein the light coupling layer comprises a low refractive index layer.

[0211] In one aspect, the OLED device further comprises a light coupling layer configured to improve light out-coupling, wherein the light coupling layer comprises a low refractive index layer composed of an aerogel.

[0212] In one aspect, the OLED device further comprises one or more of a hole transporting layer, an electron transporting layer, a hole injecting layer, an electron injecting layer, a hole blocking layer, or an electron blocking layer.

[0213] In one aspect, the OLED device active region has a lateral dimension larger than about 0.1 centimeter.

[0214] In one aspect, the OLED device active region has a lateral dimension smaller than about 1 meter.

[0215] In one aspect, the OLED device active region has a lateral dimension smaller than a characteristic distance for charge transport in the anode.

[0216] In one aspect, the OLED device active region has a lateral dimension smaller than a characteristic distance for charge transport in the anode, and wherein the lateral dimension is less than about 10 cm.

[0217] In one aspect, the OLED device active region has a lateral dimension of about 1 cm.

[0218] In another embodiment, an OLED device is provided. The OLED device comprises a substrate, an anode, a cathode, an active region comprising an organic material, wherein the active region is electrically coupled to the anode and the cathode and is configured to emit a broadband emission spectrum with a FWHM larger than about 50 nm, at least one coupler configured to electrically couple at least one of the anode or the cathode to a power supply, and an encapsulation that isolates the active region from an ambient environment, wherein the active region comprises a plurality of vertically-stacked light emitting layers.

[0219] In one aspect, the OLED device active region comprises a plurality of vertically-stacked light emitting layers, wherein at least two of the plurality of vertically-stacked light emitting layers are configured to emit light of different colors.

[0220] In one aspect, the OLED device active region comprises a plurality of vertically-stacked light emitting layers, wherein the plurality of vertically-stacked light emitting layers are interlaced with substantially transparent non-emitting layers.

[0221] In one aspect, the OLED device active region comprises a plurality of vertically-stacked light emitting layers, wherein the plurality of vertically-stacked light emitting layers are interlaced with substantially transparent non-emitting layers, and wherein the substantially transparent non-emitting layers include a third electrode, wherein the third electrode is electrically addressed differently from the anode or the cathode.

[0222] In one aspect, the OLED device active region comprises a plurality of vertically-stacked light emitting layers, wherein the plurality of vertically-stacked light emitting layers

ers are interlaced with substantially transparent non-emitting layers forming a plurality of vertically-stacked transparent OLED chips.

[0223] In one aspect, the OLED device active region comprises a plurality of vertically-stacked light emitting layers, wherein the substrate, the cathode, and the anode are substantially transparent such that the OLED device is configured to emit light in both the cathode and the anode directions.

[0224] In one aspect, the OLED device active region comprises a plurality of vertically-stacked light emitting layers, wherein at least one of the anode or the cathode is composed of a transparent material selected from a conductive oxide, a metal thin film, or an organic thin film.

[0225] In one aspect, the OLED device active region comprises a plurality of vertically-stacked light emitting layers, wherein at least one of the anode or the cathode comprises a reflective material, and wherein the OLED device is configured to be an edge emitting OLED.

[0226] In another aspect, an OLED device is provided. The OLED comprises a substrate, a first anode, a hole injection layer adjacent the first anode, a first light emitting layer, a first cathode, a second anode, a second light emitting layer, an electron transport layer, a second cathode, at least one coupler configured to electrically couple at least one of the first anode, the second anode, the first cathode, or the second cathode to a power supply, and an encapsulation that isolates the first and second light emitting layers from an ambient environment, wherein each of the first or second light emitting layers comprises an organic material and is configured to emit a broadband emission spectrum with a FWHM larger than about 50 nm, wherein the first and second light emitting layers are electrically coupled to their respective first and second anodes and cathodes.

[0227] In another aspect, an OLED device is provided. The OLED comprises a substrate, a first anode, a hole injection layer adjacent the first anode, a first light emitting layer, a first cathode, a second anode, a second light emitting layer, an electron transport layer, a second cathode, at least one coupler configured to electrically couple at least one of the first anode, the second anode, the first cathode, or the second cathode to a power supply, and an encapsulation that isolates the first and second light emitting layers from an ambient environment, wherein each of the first or second light emitting layers comprises an organic material and is configured to emit a broadband emission spectrum with a FWHM larger than about 50 nm, wherein the first and second light emitting layers are electrically coupled to their respective first and second anodes and cathodes, wherein the at least one coupler is configured to electrically couple at least one of the first anode, the second anode, the first cathode, or the second cathode to a power supply via a mount.

[0228] In another aspect, an OLED device is provided. The OLED comprises a substrate, a first anode, a hole injection layer adjacent the first anode, a first light emitting layer, a first cathode, a second anode, a second light emitting layer, an electron transport layer, a second cathode, at least one coupler configured to electrically couple at least one of the first anode, the second anode, the first cathode, or the second cathode to a power supply, and an encapsulation that isolates the first and second light emitting layers from an ambient environment, wherein each of the first or second light emitting layers comprises an organic material and is configured to emit a broadband emission spectrum with a FWHM larger than about 50 nm, wherein the first and second light emitting layers are

electrically coupled to their respective first and second anodes and cathodes, and wherein the at least one coupler is configured to electrically couple at least one of the first anode, the second anode, the first cathode, or the second cathode to a power supply via a second OLED device.

[0229] In another aspect, an OLED device is provided. The OLED comprises a substrate, a first anode, a hole injection layer adjacent the first anode, a first light emitting layer, a first cathode, a second anode, a second light emitting layer, an electron transport layer, a second cathode, at least one coupler configured to electrically couple at least one of the first anode, the second anode, the first cathode, or the second cathode to a power supply, and an encapsulation that isolates the first and second light emitting layers from an ambient environment, wherein each of the first or second light emitting layers comprises an organic material and is configured to emit a broadband emission spectrum with a FWHM larger than about 50 nm, wherein the first and second light emitting layers are electrically coupled to their respective first and second anodes and cathodes, and wherein the at least one coupler is configured to also mechanically couple the OLED device with a mount or with a second OLED device.

[0230] In another aspect, an OLED device is provided. The OLED comprises a substrate, a first anode, a hole injection layer adjacent the first anode, a first light emitting layer, a first cathode, a second anode, a second light emitting layer, an electron transport layer, a second cathode, at least one coupler configured to electrically couple at least one of the first anode, the second anode, the first cathode, or the second cathode to a power supply, and an encapsulation that isolates the first and second light emitting layers from an ambient environment, wherein each of the first or second light emitting layers comprises an organic material and is configured to emit a broadband emission spectrum with a FWHM larger than about 50 nm, wherein the first and second light emitting layers are electrically coupled to their respective first and second anodes and cathodes, and wherein the at least one coupler comprises a protrusion configured to be snapped into an indentation on a mount or a second OLED device.

[0231] In another aspect, an OLED device is provided. The OLED comprises a substrate, a first anode, a hole injection layer adjacent the first anode, a first light emitting layer, a first cathode, a second anode, a second light emitting layer, an electron transport layer, a second cathode, at least one coupler configured to electrically couple at least one of the first anode, the second anode, the first cathode, or the second cathode to a power supply, and an encapsulation that isolates the first and second light emitting layers from an ambient environment, wherein each of the first or second light emitting layers comprises an organic material and is configured to emit a broadband emission spectrum with a FWHM larger than about 50 nm, wherein the first and second light emitting layers are electrically coupled to their respective first and second anodes and cathodes, and wherein the at least one coupler comprises an indentation for a protrusion of a mount or a second device to snap therein.

[0232] In another aspect, an OLED device is provided. The OLED comprises a substrate, a first anode, a hole injection layer adjacent the first anode, a first light emitting layer, a first cathode, a second anode, a second light emitting layer, an electron transport layer, a second cathode, at least one coupler configured to electrically couple at least one of the first anode, the second anode, the first cathode, or the second cathode to a power supply, and an encapsulation that isolates the first and

second light emitting layers from an ambient environment, wherein each of the first or second light emitting layers comprises an organic material and is configured to emit a broadband emission spectrum with a FWHM larger than about 50 nm, wherein the first and second light emitting layers are electrically coupled to their respective first and second anodes and cathodes and wherein the encapsulation comprises a housing forming an enclosure with the substrate and a first sealant configured to form an oxygen and water vapor barrier for the active region.

[0233] In another aspect, an OLED device is provided. The OLED comprises a substrate, a first anode, a hole injection layer adjacent the first anode, a first light emitting layer, a first cathode, a second anode, a second light emitting layer, an electron transport layer, a second cathode, at least one coupler configured to electrically couple at least one of the first anode, the second anode, the first cathode, or the second cathode to a power supply, and an encapsulation that isolates the first and second light emitting layers from an ambient environment, wherein each of the first or second light emitting layers comprises an organic material and is configured to emit a broadband emission spectrum with a FWHM larger than about 50 nm, wherein the first and second light emitting layers are electrically coupled to their respective first and second anodes and cathodes and wherein the encapsulation comprises a housing forming an enclosure with the substrate and a first sealant configured to form an oxygen and water vapor barrier for the active region, wherein the housing has a first electrically conductive path disposed in a first hermetic seal through the housing, and wherein the first electrically conductive path is electrically coupled to the cathode.

[0234] In another aspect, an OLED device is provided. The OLED comprises a substrate, a first anode, a hole injection layer adjacent the first anode, a first light emitting layer, a first cathode, a second anode, a second light emitting layer, an electron transport layer, a second cathode, at least one coupler configured to electrically couple at least one of the first anode, the second anode, the first cathode, or the second cathode to a power supply, and an encapsulation that isolates the first and second light emitting layers from an ambient environment, wherein each of the first or second light emitting layers comprises an organic material and is configured to emit a broadband emission spectrum with a FWHM larger than about 50 nm, wherein the first and second light emitting layers are electrically coupled to their respective first and second anodes and cathodes and wherein the encapsulation comprises a housing forming an enclosure with the substrate and a first sealant configured to form an oxygen and water vapor barrier for the active region, wherein the housing has a first electrically conductive path in a first hermetic seal through the housing, and wherein the first electrically conductive path is electrically coupled to the cathode, wherein the housing further has a second electrically conductive path through the housing, and wherein the second electrically conductive path is electrically coupled to the anode.

[0235] In another aspect, an OLED device is provided. The OLED comprises a substrate, a first anode, a hole injection layer adjacent the first anode, a first light emitting layer, a first cathode, a second anode, a second light emitting layer, an electron transport layer, a second cathode, at least one coupler configured to electrically couple at least one of the first anode, the second anode, the first cathode, or the second cathode to a power supply, and an encapsulation that isolates the first and second light emitting layers from an ambient environment,

wherein each of the first or second light emitting layers comprises an organic material and is configured to emit a broadband emission spectrum with a FWHM larger than about 50 nm, wherein the first and second light emitting layers are electrically coupled to their respective first and second anodes and cathodes and wherein the encapsulation comprises a housing forming an enclosure with the substrate and a first sealant configured to form an oxygen and water vapor barrier for the active region, wherein the housing has a first electrically conductive path in a first hermetic seal through the housing, and wherein the first electrically conductive path is electrically coupled to the cathode, wherein the housing further has a second electrically conductive path through the housing, and wherein the second electrically conductive path is electrically coupled to the anode, wherein the second electrically conductive path is through a second hermetic seal.

[0236] In another aspect, an OLED device is provided. The OLED comprises a substrate, a first anode, a hole injection layer adjacent the first anode, a first light emitting layer, a first cathode, a second anode, a second light emitting layer, an electron transport layer, a second cathode, at least one coupler configured to electrically couple at least one of the first anode, the second anode, the first cathode, or the second cathode to a power supply, and an encapsulation that isolates the first and second light emitting layers from an ambient environment, wherein each of the first or second light emitting layers comprises an organic material and is configured to emit a broadband emission spectrum with a FWHM larger than about 50 nm, wherein the first and second light emitting layers are electrically coupled to their respective first and second anodes and cathodes and wherein the encapsulation comprises a housing forming an enclosure with the substrate and a first sealant configured to form an oxygen and water vapor barrier for the active region, wherein the housing is electrically conductive, and wherein the first electrically conductive path is electrically isolated from the housing, and further wherein the anode is electrically coupled to the housing.

[0237] In another aspect, an OLED device is provided. The OLED comprises a substrate, a first anode, a hole injection layer adjacent the first anode, a first light emitting layer, a first cathode, a second anode, a second light emitting layer, an electron transport layer, a second cathode, at least one coupler configured to electrically couple at least one of the first anode, the second anode, the first cathode, or the second cathode to a power supply, and an encapsulation that isolates the first and second light emitting layers from an ambient environment, wherein each of the first or second light emitting layers comprises an organic material and is configured to emit a broadband emission spectrum with a FWHM larger than about 50 nm, wherein the first and second light emitting layers are electrically coupled to their respective first and second anodes and cathodes and wherein the encapsulation comprises a housing forming an enclosure with the substrate and a first sealant configured to form an oxygen and water vapor barrier for the active region, wherein the housing is electrically conductive, and wherein the first electrically conductive path is electrically isolated from the housing, and further wherein the anode is electrically coupled to the housing, wherein the electrically conductive housing forms a common anode with neighboring OLED devices.

[0238] In another aspect, an OLED device is provided. The OLED comprises a substrate, a first anode, a hole injection layer adjacent the first anode, a first light emitting layer, a first cathode, a second anode, a second light emitting layer, an

electron transport layer, a second cathode, at least one coupler configured to electrically couple at least one of the first anode, the second anode, the first cathode, or the second cathode to a power supply, and an encapsulation that isolates the first and second light emitting layers from an ambient environment, wherein each of the first or second light emitting layers comprises an organic material and is configured to emit a broadband emission spectrum with a FWHM larger than about 50 nm, wherein the first and second light emitting layers are electrically coupled to their respective first and second anodes and cathodes and wherein the encapsulation comprises a housing forming an enclosure with the substrate, and a first sealant configured to form an oxygen and water vapor barrier for the active region, wherein the housing is electrically conductive, and wherein the first electrically conductive path is electrically isolated from the housing, and further wherein the anode is electrically coupled to the housing, wherein the housing has a contoured shape that allows the OLED device to be arranged on a curved surface with a plurality of neighboring OLED devices without causing substantial interference between housings of neighboring OLED devices.

[0239] In another aspect, an OLED device is provided. The OLED comprises a substrate, a first anode, a hole injection layer adjacent the first anode, a first light emitting layer, a first cathode, a second anode, a second light emitting layer, an electron transport layer, a second cathode, at least one coupler configured to electrically couple at least one of the first anode, the second anode, the first cathode, or the second cathode to a power supply, and an encapsulation that isolates the first and second light emitting layers from an ambient environment, wherein each of the first or second light emitting layers comprises an organic material and is configured to emit a broadband emission spectrum with a FWHM larger than about 50 nm, wherein the first and second light emitting layers are electrically coupled to their respective first and second anodes and cathodes, and wherein the encapsulation comprises a housing forming an enclosure with the substrate and a first sealant configured to form an oxygen and water vapor barrier for the active region, wherein the housing is electrically conductive, and wherein the first electrically conductive path is electrically isolated from the housing, and further wherein the anode is electrically coupled to the housing, wherein the housing has a contoured shape that allows the OLED device to be arranged on a curved surface with a plurality of neighboring OLED devices without causing substantial interference between housings of neighboring OLED devices, wherein the housing has a slanted side wall and a bottom wall, and wherein a slant angle of the slanted side wall is selected such that, when the OLED device is tightly arranged with a plurality of neighboring OLED devices on a curved surface, housings of neighboring OLED devices do not substantially interfere with each other.

[0240] In another aspect, an OLED device is provided. The OLED comprises a substrate, a first anode, a hole injection layer adjacent the first anode, a first light emitting layer, a first cathode, a second anode, a second light emitting layer, an electron transport layer, a second cathode, at least one coupler configured to electrically couple at least one of the first anode, the second anode, the first cathode, or the second cathode to a power supply, and an encapsulation that isolates the first and second light emitting layers from an ambient environment, wherein each of the first or second light emitting layers comprises an organic material and is configured to emit a broadband emission spectrum with a FWHM larger than about 50

nm, wherein the first and second light emitting layers are electrically coupled to their respective first and second anodes and cathodes and wherein the encapsulation comprises a substantially hexagonal housing forming an enclosure with the substrate.

[0241] In another aspect, an OLED device is provided. The OLED comprises a substrate, a first anode, a hole injection layer adjacent the first anode, a first light emitting layer, a first cathode, a second anode, a second light emitting layer, an electron transport layer, a second cathode, at least one coupler configured to electrically couple at least one of the first anode, the second anode, the first cathode, or the second cathode to a power supply, and an encapsulation that isolates the first and second light emitting layers from an ambient environment, wherein each of the first or second light emitting layers comprises an organic material and is configured to emit a broadband emission spectrum with a FWHM larger than about 50 nm, wherein the first and second light emitting layers are electrically coupled to their respective first and second anodes and cathodes and wherein the encapsulation comprises a housing forming an enclosure with the substrate and a first sealant configured to form an oxygen and water vapor barrier for the active region, wherein the enclosure is filled with an inert gas at a pressure higher than an atmospheric pressure.

[0242] In another aspect, an OLED device is provided. The OLED comprises a substrate, a first anode, a hole injection layer adjacent the first anode, a first light emitting layer, a first cathode, a second anode, a second light emitting layer, an electron transport layer, a second cathode, at least one coupler configured to electrically couple at least one of the first anode, the second anode, the first cathode, or the second cathode to a power supply, and an encapsulation that isolates the first and second light emitting layers from an ambient environment, wherein each of the first or second light emitting layers comprises an organic material and is configured to emit a broadband emission spectrum with a FWHM larger than about 50 nm, wherein the first and second light emitting layers are electrically coupled to their respective first and second anodes and cathodes wherein the encapsulation comprises a housing forming an enclosure with the substrate and a first sealant configured to form an oxygen and water vapor barrier for the active region, wherein the housing has a substantially hexagonal shape such that the OLED device is configured to be neighboring six other polygonal OLED devices to form a matrix.

[0243] In another aspect, an OLED device is provided. The OLED comprises a substrate, a first anode, a hole injection layer adjacent the first anode, a first light emitting layer, a first cathode, a second anode, a second light emitting layer, an electron transport layer, a second cathode, at least one coupler configured to electrically couple at least one of the first anode, the second anode, the first cathode, or the second cathode to a power supply, and an encapsulation that isolates the first and second light emitting layers from an ambient environment, wherein each of the first or second light emitting layers comprises an organic material and is configured to emit a broadband emission spectrum with a FWHM larger than about 50 nm, wherein the first and second light emitting layers are electrically coupled to their respective first and second anodes and cathodes and wherein the first and second light emitting layers are activated independently.

[0244] In one aspect, a kit of pre-manufactured modular OLED devices is provided, wherein the OLED devices include at least two types of OLED devices of different col-

ors, each OLED device comprising a substrate, an anode, a cathode, and an active region comprising an organic material, wherein the active region is electrically coupled to the anode and the cathode and is configured to emit a broadband emission spectrum with a FWHM larger than about 50 nm; at least one coupler configured to electrically couple at least one of the anode or the cathode to a power supply; and an encapsulation that isolates the active region from an ambient environment.

[0245] In one aspect, the kit further comprises a mount for receiving at least some of the plurality of OLED devices, wherein the mount is configured to electrically couple the power supply and the at least some of the plurality of OLED devices.

[0246] In one aspect, the kit further comprises a plurality of conductive couplers, wherein each of the plurality of conductive couplers has at least one conductive surface area and at least one insulating surface area at predetermined locations for electrically coupling one of the OLED devices with another OLED device or with a mount.

[0247] In one aspect, the kit is provided wherein at least one of the plurality of OLED devices has one or more via holes for receiving an elongated conductor.

[0248] In one aspect, the kit is provided wherein at least one of the plurality of OLED devices has one or more via holes for receiving an elongated conductor, and wherein the elongated conductor is flexible.

[0249] In one aspect, the kit is provided wherein at least one of the plurality of OLED devices has one or more via holes for receiving an elongated conductor, and wherein the elongated conductor is configured to also mechanically couple one of the OLED devices with another one of the OLED devices or with a mount.

[0250] In one aspect, the kit further comprises an elongated conductor, wherein at least one of the plurality of OLED devices has one or more via holes for receiving the elongated conductor, and wherein the elongated conductor is configured to also mechanically couple one of the OLED devices with another one of the OLED devices or with a mount.

[0251] In one aspect, the kit further comprises a flexible elongated conductor, wherein at least one of the plurality of OLED devices has one or more via holes for receiving the flexible elongated conductor.

[0252] In one aspect, the kit further comprises a mount, wherein at least one of the plurality of OLED devices is configured to be coupled to the mount.

[0253] In one aspect, the kit further comprises a mount and a power supply, wherein at least one of the plurality of OLED devices is configured to be mechanically coupled to the mount, and electrically coupled to the power supply via the mount.

[0254] In another embodiment, a method of manufacturing an OLED device is described. The steps comprise: providing a substrate, an anode, a cathode, and an active region comprising an organic material, and a housing, wherein the active region is electrically coupled to the anode and the cathode and is configured to emit a broadband emission spectrum with a full width at half maximum (FWHM) larger than about 50 nm; and assembling the substrate, the anode, the cathode, the active region and the housing to form the OLED device.

[0255] In one aspect, the method is provided wherein assembling comprises: disposing the housing over the substrate; and sealing the housing onto the substrate using a first

sealant thereby forming an encapsulation that isolates the active region from an ambient environment.

[0256] In one aspect, the method is provided wherein the assembling comprises sealing the housing onto the substrate using a first sealant thereby forming an enclosure that isolates the active region from an ambient environment, wherein the sealing is performed in an inert gas at a pressure equal to or higher than an ambient atmospheric pressure.

[0257] In one aspect, the method is provided wherein the assembling comprises sealing the housing onto the substrate using a first sealant thereby forming an enclosure that isolates the active region from an ambient environment, wherein the sealing comprises performing the sealing in an inert gas at a pressure equal to or higher than an ambient atmospheric pressure, and wherein the pressure is between about 1.0 and 1.5 times the ambient atmospheric pressure.

[0258] In one aspect, the method is provided wherein the assembling comprises sealing the housing onto the substrate using a first sealant thereby forming an enclosure that isolates the active region from an ambient environment, wherein the sealing is performed in an inert gas at a pressure higher than an ambient atmospheric pressure, wherein the substrate is an un-diced substrate, the method further comprising dicing the substrate after sealing the housing onto the substrate.

[0259] In one aspect, the method is provided wherein the assembling comprises sealing the housing onto the substrate using a first sealant thereby forming an enclosure that isolates the active region from an ambient environment, wherein the sealing is performed in an inert gas at a pressure equal to or higher than an ambient atmospheric pressure, and wherein the sealing comprises sealing the housing onto a first side of the substrate, the method further comprising: disposing a second sealant over a second side of the substrate opposite a first side that is in contact with the first sealant; and bending an edge portion of the housing around the second sealant.

[0260] In one aspect, the method is provided wherein the assembling comprises sealing the housing onto the substrate using a first sealant thereby forming an enclosure that isolates the active region from an ambient environment, wherein the sealing is performed in an inert gas at a pressure equal to or higher than an ambient atmospheric pressure, and wherein the sealing comprises sealing the housing onto a first side of the substrate, the method further comprising: disposing a second sealant over a second side of the substrate opposite a first side that is in contact with the first sealant; and bending an edge portion of the housing around the second sealant; and sealing a gap between the edge portion of the housing and the OLED chip.

[0261] In another embodiment, an OLED device is provided. The OLED device comprises a substrate; an anode; a cathode; an active region comprising an organic material, wherein the active region is electrically coupled to the anode and the cathode; at least one coupler; and an encapsulation that isolates the active region from an ambient environment.

[0262] In a further embodiment, the coupler is configured to electrically couple at least one of the anode or the cathode to a power supply.

[0263] In one aspect, an OLED device is provided, comprising a substrate; an anode; a cathode; an active region comprising an organic material, wherein the active region is electrically coupled to the anode and the cathode; at least one coupler; and an encapsulation that isolates the active region from an ambient environment, wherein the coupler is config-

ured to mechanically couple the OLED device with a mount or with one or more other OLED devices.

[0264] In one aspect, an OLED device is provided, comprising a substrate; an anode; a cathode; an active region comprising an organic material, wherein the active region is electrically coupled to the anode and the cathode; at least one coupler; and an encapsulation that isolates the active region from an ambient environment, wherein the coupler is configured for both electrical and mechanical coupling the OLED device with an article.

[0265] In another embodiment, a lighting system is provided, comprising a plurality of OLED devices, wherein each of the OLED devices comprises: a substrate; an anode; a cathode; an active region comprising an organic material, wherein the active region is electrically coupled to the anode and the cathode; at least one coupler configured to electrically couple at least one of the anode or the cathode to a power supply; and an encapsulation that isolates the active region from an ambient environment.

[0266] In one aspect, the lighting system further comprises a mount, wherein at least some of the plurality of OLED devices are removably coupled to the mount through their respective couplers.

[0267] In one aspect, the lighting system is provided wherein at least some of the plurality of OLED devices have different colors, and wherein the plurality of OLED devices are selected such that the lighting system emits light of desired color characteristics.

[0268] In one aspect, the lighting system further comprises: a mount; and an elongated conductor for coupling at least some of the plurality of OLED devices to the mount.

[0269] In one aspect, the lighting system further comprises: a mount; and an elongated conductor for coupling at least some of the plurality of OLED devices to the mount, wherein the elongated conductor has a patterned surface including insulating and conductive regions.

[0270] In one aspect, the lighting system further comprises: a mount including a plurality of conductive layers; and a plurality elongated conductor for coupling at least some of the plurality of OLED devices to the mount, wherein at least some of the plurality of elongated conductor insulating regions at locations corresponding to the plurality of conductive layers.

[0271] In one aspect, the lighting system further comprises: a mount including a plurality of conductive layers; and an elongated conductor for coupling at least some of the plurality of OLED devices to the mount, wherein the elongated conductor has at least two arms, and wherein each of the at least two arms has insulating regions at locations corresponding to the plurality of conductive layers.

[0272] In one aspect, the lighting system further comprises: a mount including a plurality of conductive layers; and an elongated conductor for coupling at least some of the plurality of OLED devices to the mount, wherein the elongated conductor is substantially U-shaped.

[0273] The FIGS. 1-12 provided herein are exemplary embodiments. Other embodiments can be carried out by one skilled in the art within the spirit and scope of the claims.

1-43. (canceled)

44. An OLED device comprising multiple electrodes, wherein at least one of the multiple electrodes is electrically isolated from an active region of the OLED device.

45. The OLED device of claim 44, wherein the electrically isolated electrode is configured to provide an electrical connection between at least two couplers or OLED devices, between a power supply and at least one coupler or OLED device, or between at least one OLED device and at least one coupler.

46-59. (canceled)

* * * * *