

(19)



Europäisches Patentamt
European Patent Office
Office européen des brevets



(11)

EP 0 540 140 B1

(12)

EUROPEAN PATENT SPECIFICATION

(45) Date of publication and mention
of the grant of the patent:
25.03.1998 Bulletin 1998/13

(51) Int Cl.⁶: **G02F 1/1335**

(21) Application number: **92305457.1**

(22) Date of filing: **15.06.1992**

(54) Backlighting system for electro-optic displays

Hintergrundbeleuchtungssystem für elektrooptische Anzeigen

Système d'éclairage par transmission pour affichages à électro-optique

(84) Designated Contracting States:
DE FR GB

(30) Priority: **01.11.1991 US 786484**

(43) Date of publication of application:
05.05.1993 Bulletin 1993/18

(73) Proprietor: **LITTON SYSTEMS CANADA LIMITED**
Etobicoke Ontario M9W 5A7 (CA)

(72) Inventor: **Farrell, James Francis**
Etobicoke, Ontario M9B531 (CA)

(74) Representative: **Godsill, John Kenneth et al**
Haseltine Lake & Co.,
Imperial House,
15-19 Kingsway
London WC2B 6UD (GB)

(56) References cited:
EP-A- 0 364 346 **US-A- 3 950 078**
US-A- 4 573 766 **US-A- 4 799 771**
US-A- 4 934 793 **US-A- 5 046 826**

EP 0 540 140 B1

Note: Within nine months from the publication of the mention of the grant of the European patent, any person may give notice to the European Patent Office of opposition to the European patent granted. Notice of opposition shall be filed in a written reasoned statement. It shall not be deemed to have been filed until the opposition fee has been paid. (Art. 99(1) European Patent Convention).

Description

This invention relates to a backlighting system for electro-optical displays and is applicable to, but not limited to, an apparatus and method to allow an active matrix liquid crystal display to be viewed.

Active matrix liquid crystal displays are presently being developed and used widely as instrument monitors in many fields of use. Particularly, it is advantageous to make use of flat liquid crystal displays in the cockpit instrumentation panel where the status of various sensors are displayed for viewing by the pilot. In the past, such displays contained cathode ray tubes (CRT) to convert the electronic information to visual pictures of the data viewable by the pilot. CRT displays require considerable volume for their installation. The advantage of any flat-panel displays such as active matrix liquid crystal displays is obvious.

Liquid crystal displays can be constructed as multi and full color displays in several ways. One way is to use fluorescent lamps excited by ultraviolet radiation as a backlighting panel. The light from this bright flat-panel is modulated by the LCD to create the patterns of information bearing pictures on the display for viewing by the operator. The backlighting panel can be a fluorescent white lamp with proper filters or of a properly organized blue-green-red matrix fluorescent phosphor structure.

Several types of fluorescent lighting for LCD backlighting have been developed and used. One type, as an example, is a flat fluorescent lamp similar to that reported in the article "Flat Fluorescent Lamp for LCD Back-light" by K. Hinotani, S. Kishimoto, and K. Terada, 1988 Society for Information Display, International Display Research Conference, pp. 52-55. Hinotani et al shows the construction of a flat-panel fluorescent lamp designed for use in small size portable LCD televisions.

United States Patent No. 4,842,378 by Flasck et al presents a method of illuminating flat panel displays utilizing a serpentine shaped fluorescent tube which is placed adjacent to the back screen of the panel to back-light the screen. Also shown in this patent is the use of individual fluorescent tubes spaced parallel to one other along a back plane to create the backlighting for flat-panel display purposes.

United States Patent No. 4,748,546 by Ukrainsky presents a similar use of fluorescent tubes where such fluorescent tubes are embedded in RTV rubber or other transparent potting material, and with the use of diffusing layers becomes a backlighting device for a flat panel display.

In addition to the use of fluorescent tubes other methods of providing light sources have been suggested. The United States Patent No. 4,573,766 by Bournay, Jr. et al presents a light emitting diode (LED) backlighting panel with the LED light sources installed in side edges of the solid state panel. The panel then serves as a wave guide to distribute the light along a roughened surface perpendicular to the edges where the LED's are

installed. At the roughened surface the light is diffused upward through the LCD and display area.

Each of these methods of lighting a flat-panel display, and others not mentioned here, provide the capability and facility of emitting light at high intensity quite suitable for daylight viewing. In many cases, particularly military uses, it becomes necessary to be capable of viewing the same display during dark conditions where the viewer is utilizing night vision electronic equipment. Such night vision electronic equipment usually is designed to be sensitive to very low light level intensities, frequently in the near infrared region.

Any near infrared source of light at an intensity above the surrounding night time conditions will have the tendency to cause night vision electronic viewing equipment to overload and cease functioning. Quite clearly then, the use of LCD displays designed for daylight use became a handicap at night in an aircraft where a pilot is relying on night vision equipment to view the environment about him.

EP-A-0364346 discloses a backlit electrooptical modulated light valve display device using first means for emitting light for daylight viewing and second means for emitting relatively low intensity light for use in dark conditions with night vision equipment. In order to reduce the infrared content of the light at night EP-A-036436 teaches the use of fluorescent tubes, with those of the second means having a spectrum which has a low infrared content. The display device of the embodiment has the tubes of the first means interdigitating the tubes of the second means.

According to a first aspect of the invention, there is provided a backlit electrooptic modulated light valve display device which comprises an electrooptic light valve panel for controllably modifying light being transmitted therethrough into patterns of information, first means for emitting relatively high intensity light, the first means comprising an electrically energised light source means and means for directing the light generated by the light source means at a rear surface of and through said electrooptic light valve panel with sufficient intensity for daylight viewing of the display, and second means for emitting relatively low intensity light through said electrooptic light valve panel for use in viewing the panel in dark conditions with night vision equipment whilst the means for emitting relatively high intensity light is deactivated by deenergising the light source means, characterised in that the first means are disposed in a zone extending from the rear surface of the panel, the second means are disposed outside that zone, so as not to be interposed between portions of the first means nor between the first means and the panel, and being arranged to direct the relatively low intensity light to the panel via said zone, and there are infrared filter means for filtering the light from the second means before or as it enters said zone.

Preferred embodiments of the first aspect are based upon the concept of the inventor that it would be

desirable to develop a method whereby the intensity of light emitted by an LCD display in the near infrared spectrum is sufficiently low as not to interfere with the operation of night vision equipment and would thus allow the operator the ability to view such display through the night vision equipment.

One possible solution to this problem is the design of an optical filter for the display surface which would allow sufficient visible throughput for daylight observation while maintaining sufficient suppression of the transmission of wavelengths that night vision equipment are susceptible to, e.g. infrared (IR). Several studies were conducted by the inventor on candidate filters for such a purpose. Unfortunately, the results revealed that those filters which would reduce the IR portion of the spectrum simultaneously did not have the best visible transmission. Therefore, with the reduced visible transmission, operation under daylight conditions was handicapped by the reduced brightness of visible light available at the display.

In contrast, it will be appreciated that embodiments of the first aspect of the invention can be designed to provide converting a standard fluorescent activated backlit display suitable for daylight viewing into a simultaneously display capability of emitting very low-level light intensity during dark viewing conditions with night vision equipment.

For example, by the addition of an IR filtered secondary matrix of fluorescent light sources, or light emitting diodes or miniature low-level incandescent lamp light sources, outside the zone occupied by the standard daylight source(s) one attains ability to convert a standard fluorescent backlit active matrix liquid crystal display into a display capable of effective viewing during daylight conditions with the unaided eye and during dark night conditions with the observers eyes augmented by night vision electronic equipment.

Thus one may leave the design of a backlit liquid crystal display in its standard form for daylight viewing with the unaided eye and add to it secondary arrays of fluorescent light tubes augmented with filters and diffusers, or arrays of miniature LED or arrays of filtered incandescent low-level light sources. Secondary fluorescent light sources will need little colour balance adjustment since they compliment the same technique used for daylight viewing. Although the discussion is focused mainly on LCD type displays, it is to be recognized that the invention is applicable to any backlit display where an electrooptic modulated light valve functions as the medium for controllably modifying light being transmitted through it into readable patterns of information.

Low-level miniature light sources can be installed in a manner to emit a balanced white color to optimize the color control of the transmitted light by the LCD. These low intensity miniature sources can be a combination or red, blue and green light sources respectively. The relative intensity of the red, blue and green light can be individually adjusted so that the color balance of the

display is selectable.

According to a second aspect of the invention, there is provided a backlit electrooptic modulated light valve display device which comprises an electrooptic light valve panel for controllably modifying light being transmitted therethrough into patterns of information, first means for emitting relatively high intensity light, the first means comprising an electrically energised light source means and means for directing the light generated by the light source means at a rear surface of and through said electrooptic light valve panel and with sufficient intensity for daylight viewing of the display, and second means for emitting relatively low intensity light through said electrooptic light valve panel for use in viewing the panel in dark conditions with night vision equipment whilst the means for emitting relatively high intensity light is deactivated by deenergising the light source means, characterised in that the first means are disposed in a zone extending from a rear surface of the panel, the second means are disposed outside that zone, so as not to be interposed between portions of the first means nor between the first means and the panel, and being arranged to direct the relatively low intensity light to the panel via said zone through diffusing portions of the first means in said zone to diffuse that light before that low intensity light reaches the panel.

For example, the use of secondary arrays of fluorescent lamps can involve placing them below primary fluorescent tubes in a manner such that filters and diffusers can be interposed to reduce the light intensity from the secondary array, and also to allow the light from the secondary array to further diffuse through portions of the primary fluorescent tubes used for daylight viewing. During low light viewing, the primary fluorescent tubes are deactivated.

The miniature low-level lamps are preferably chosen so that their emission is night vision compatible; there is then no need to optically filter the emission of the primary fluorescent tubes by the use of a specially designed filter. Again, during night time viewing, the primary fluorescent lamps are turned off.

If miniature low-level lamps are located directly behind the fluorescent tubes, the light from the low-level miniature lamps is diffused by the tubes. This diffusion will tend to spread the low-level light evenly across the surface of the display, as is designed to occur when such primary fluorescent tubes are activated to create normal backlighting during daylight viewing.

If the low-level lamps are arrayed and located not to reside directly behind existing fluorescent tubes, the use of a diffusing plate can be used as may be necessary. This diffusing plate may be located either at the liquid crystal display or just above the low-level intensity lamps.

The above location of the low-level intensity lamps in the back plane of the backlighting source is effective for those backlit sources utilizing fluorescent lighting tubes or flat fluorescent lamps wherein the entire cavity

behind the liquid crystal display functions as a fluorescent source of light.

Other embodiments introduce the use of miniature low-level intensity lamps with solid state light guide devices usually containing a roughened surface to cause light transmitting within the light guide medium to reflect in a diffused manner towards and through the liquid crystal display viewing area. Such solid state light guide systems are also usually illuminated by a fluorescent lamp source, although other forms of light source located along the edges of the light guide can be used. To convert this form of backlighting, one embodiment utilizes low-level intensity light sources located behind existing fluorescent lamps in a similar manner as described above.

For a better understanding of the invention and to show how the same may be carried into effect, reference will now be made, by way of example, to the accompanying drawings, in which:

Figure 1 shows a cut away view of the construction of a backlit display utilizing primary fluorescent light tubes backed by holes for housing low-level miniature lamp sources.

Figure 2 is a cross-sectional view of Figure 1 on line 2-2 showing low-level light sources beneath fluorescent light tubes.

Figure 3 shows a cut away view of the construction of a flat fluorescent lamp which functions as a backlighting source.

Figure 4 is a cross-sectional view on line 4-4 of Figure 3 showing low-level light sources.

Figure 5 is a partial cross-sectional view of a fluorescent lamp backlighting source showing an alternative construction for low-level light sources.

Figure 6 shows a solid state light wave guide backlighting source illuminated by side mounted fluorescent light tubes.

Figure 7 shows a view of the solid state backlighting source system of Figure 6 augmented with low-level light sources.

Figure 8 shows a cut away view of the construction of a backlit display utilizing primary fluorescent light tubes backed by slots positioned to allow low-level light from secondary fluorescent light tubes to filter through.

Figure 9 is a cross-sectional view on line 9-9 of Figure 8 showing emission of low-level light from secondary fluorescent sources beneath primary fluorescent light tubes.

The preferred embodiment now to be described is a backlit liquid crystal display panel which is readable with the unaided eye under bright lighting conditions of daylight and is also readable with night vision equipment under dark conditions of night, and which comprises the elements of a liquid crystal panel 12, or any other electrooptically modulated light valve that controllably modifies the light being transmitted through the panel into readable color patterns of information, a means for emitting relatively high intensity light through the liquid crys-

tal panel and which has an intensity suitable for daylight viewing of the display, and a means for emitting relatively low intensity light through the crystal panel for viewing in dark conditions with night vision equipment. In the usual case, fluorescent lighting tubes are used to provide the high intensity light sources for daylight viewing of the display. To the inventors knowledge, at the present, no suitable light source has been suggested or implied for providing a low intensity capability for use with electronic night vision equipment except for the invention presented herein.

A preferred embodiment of a liquid crystal display panel is shown in Figures 8 and 9. This embodiment utilizes primary fluorescent light tubes 18 either formed in a continuous serpentine fashion to attempt to achieve light distribution evenly over liquid crystal display panel 12, or alternatively by using fluorescent light tubes 18 positioned parallel to one another behind said liquid crystal panel display or electrooptically modulated light valve unit 12. Figure 8 illustrates the general construction for an LCD display utilizing separate, parallel fluorescent light tubes 18 positioned behind liquid crystal display panel 12. Figure 9 shows a cross-sectional view on line 9-9 in Figure 8.

A reflector body 24 is placed behind fluorescent tubes 18 to reflect light emitted in the reverse direction of the fluorescent tubes back towards LCD 12 in a manner to encourage or enhance an even distribution of light intensity on the LCD. In this example, a reflecting surface 20 of reflector body 24 is sculptured to form cylindrically circular or parabolic reflection behind fluorescent tubes 18 as desired for the particular circumstance.

Light emitted during daylight operating conditions is exhibited in Figure 9 by rays 30 emanating from the fluorescent light tubes. As shown, it is seen that forward emitted rays proceed directly towards and through LCD panel 12 while the back side rays are reflected from surface 20. This illustrates the normal manner of operation for daytime viewing where the LCD display unit can be read with high brightness and good contrast. As a general rule, a diffuser plate 16 is placed in the path of the backlighting rays before they reach LCD 12. The diffuser 16 tends to smooth out the light intensity to aid in obtaining even intensity across the entire surface area of the LCD.

In this embodiment slots 23 are cut through reflector body 24 just below the location of primary fluorescent tubes 18. The length and width of such slots will depend upon the particular size and design for the display area required. Mounted behind slots 23 are secondary fluorescent tubes 37. Interposed between fluorescent tubes 37 and slots 23 may be a filter plate 39.

For low light level operation, primary fluorescent tubes 18 are turned off and secondary fluorescent sources 37 are turned on. Light radiating from tubes 37 passes through filter plate 39 and slots 23 before being intercepted by primary fluorescent tubes 18. The intensity and light balance of the low-level light is controlled

by the choice for filter 39 and by adjustment of the power to secondary fluorescent tubes 37. The low-level light is further diffused and scattered by primary fluorescent tubes 18 and, finally, is emitted smoothly as rays 34 before transiting LCD panel 12.

In another preferred embodiment for a liquid crystal display panel, backlighting is again created by fluorescent light tubes either formed in a continuous serpentine fashion or by using separate fluorescent light tubes positioned parallel to one another behind liquid crystal panel 12 display unit. Figure 1 illustrates the general construction for an LCD display utilizing separate fluorescent light tubes 18 positioned behind liquid crystal display panel 12.

Figure 2 shows a cross-sectional view on line 2-2 in Figure 1 which further aid to view the construction configuration. A reflector body 24 is again placed behind the fluorescent tubes 18 to reflect light emitted in the reverse direction of the fluorescent tubes back towards LCD 12 in a manner to encourage or enhance an even distribution of light intensity on the LCD panel. Light emitted during daylight operating conditions is exhibited in Figure 2 by the rays 30 emanating from the fluorescent light tubes. Again, diffuser plate 16 is placed in the path of the backlighting rays before they reach the LCD to smooth out the light intensity across the entire surface area of LCD panel 12.

This embodiment has the insertion within reflector block 24 of low-level light sources 38. For the particular embodiment shown in Figures 1 and 2, the placement of these low-level light sources 22 are more effectively located along the axis and behind each fluorescent light tube 18. By this arrangement, as shown in Figure 2, low-level light emitted by light source 38, represented by rays 32, will be intercepted by the fluorescent light tubes and reradiated for the most part as rays 34. This effect serves to provide a diffusing nature to light reaching LCD 12. The net result is a low intensity, diffused light level impinging on LCD 12 which is well balanced across the surface area. The further use of a diffuser 16 is not generally necessary, although depending on the circumstances is capable of being applied as required.

The low-level light sources 38 may be either incandescent or light emitting diodes (LED). These light sources may also be constructed with lenses to aid focusing their emitted light into fluorescent light tubes 18. Various color low-level sources may be placed in their locations in a manner that they may be adjusted and controlled to yield light of a proper color, usually white, for transmission and modification by the LCD.

In this embodiment red, blue and green lights are used and adjusted so that a white color balance to the display is selectable. With these miniature, low-level light sources chosen so that their emission is night vision compatible, there is no need to operate the fluorescent tubes. During night vision operation such fluorescent light tubes would be turned off. In the event that selected low-level light sources emit a higher than desired inten-

sity in the near infrared, small night vision filter inserts 36 may be placed to reduce the intensity emitted by low-level light sources 38 to an acceptable level.

Fig. 3 shows a modification in which a flat fluorescent light source 52 is constructed of an upper glass panel 54 and a lower glass panel 58. Each of these glass panels contains a phosphor layer 56 on its inner surface. Electrodes for activating the fluorescent cavity are located at sides 60 to cavity 52.

The combination of upper glass panel 54, lower glass panel 58, phosphor layers 56, and electrodes 60 make up the flat fluorescent light source. An activate matrix LCD or electrooptically modulated light valve 62 is located above said light source. Daylight viewing would be accomplished with the above described combination. A diffuser plate, if necessary, could be inserted between LCD 62 and the flat luminescent light source.

Figures 4 and 5 show cross-sectional cutaways of lower glass panel 58 with installation of low-level intensity light sources. In Figure 4 low-level light sources 68 are installed in lower glass panel 58. Again, as may be required, small night vision filter 66 may be placed to reduce the intensity or correct the emission spectrum of low-level light sources 68. As shown, the low-level light sources are installed below phosphor layer 56 on lower glass plate 58. Figure 3 illustrates one manner of arraying the location 64 of the low-level light sources on the surface area of plate 58. Of course, it is to be recognized that many array configurations are possible. In cases where further diffusion of light emitted by arrays 64 of low-level light sources is desired, a diffuser 70 may be installed on lower glass panel 58 beneath phosphor layer 56. This diffuser 70 can further smooth and aid in distributing the intensity across the surface area in a more uniform manner.

Figure 6 illustrates a solid state optical plate 82 used as a lightwave guide for backlighting an LCD. Fluorescent light tubes 84 illuminate the edges of light guide 82. Lightwaves 88 emanating from fluorescent tubes 84 move through waveguide 82 by reflecting from one surface to the other back and forth across the width of the light guide. The lower surface 86 of light guide 82 is roughened slightly to cause diffused scattering of light rays 88. This results in a diffused spread of light rays 90 in the direction towards the LCD. This diffused reflection occurs continuously throughout waveguide 82 along surface 86. By this means, the LCD is illuminated from behind with a reasonably uniform field of light across its surface area.

In Figure 7, light guide 82 is shown configured on two sides by fluorescent light tubes 84 and augmented on all four sides by distributed arrays of low-level intensity light sources 92. Therefore, the same principle as illustrated in the examples described above can be effective through light guide 82.

During daylight viewing, fluorescent light tubes 84 illuminate through light guide 82 to allow bright and high contrast viewing of the LCD. For night time viewing

through night vision equipment, fluorescent tubes 84 are turned off and the low-level light sources located in arrays 92 are activated. Again, varying colored incandescent low-level light sources or LED sources are distributed over light arrays 92. Adjustment of the combinations of colors used such as blue, red, and green light, allow for establishing a desired white color balance throughout light guide 82. The installation of low-level light sources in arrays 92 may again be augmented with small night vision filter such as shown as 66 in Figures 4 and 5.

While these specific embodiments of the invention herein have been illustrated and described in detail, it will be appreciated that the invention is not limited thereto, since many modifications may be made by one skilled in the art which fall within the claims.

Claims

1. A backlit electrooptic modulated light valve display device which comprises an electrooptic light valve panel (12) for controllably modifying light being transmitted therethrough into patterns of information, first means (18) for emitting relatively high intensity light, the first means comprising an electrically energised light source means (18) and means (16, 20) for directing the light generated by the light source means at a rear surface of and through said electrooptic light valve panel (12) and with sufficient intensity for daylight viewing of the display, and second means (37) for emitting relatively low intensity light through said electrooptic light valve panel (12) for use in viewing the panel in dark conditions with night vision equipment whilst the means (18) for emitting relatively high intensity light is deactivated by deenergizing the light source means (18), characterised in that the first means are disposed in a zone extending from the rear surface of the panel, the second means are disposed outside that zone, so as not to be interposed between portions of the first means nor between the first means and the panel, and being arranged to direct the relatively low intensity light to the panel via said zone, and there are infrared filter means for filtering the light from the second means before or as it enters said zone.
2. A device according to claim 1 wherein the second means (37) are arranged to direct light into said zone and through diffusing portions (18) of the first means before that light reaches the panel.
3. A backlit electrooptic modulated light valve display device which comprises an electrooptic light valve panel (12) for controllably modifying light being transmitted therethrough into patterns of information, first means (18) for emitting relatively high intensity light, the first means comprising an electrically energised light source means (18) and means (16, 20) for directing the light generated by the light source means at a rear surface of and through said electrooptic light valve panel (12) and with sufficient intensity for daylight viewing of the display, and second means (37) for emitting relatively low intensity light through said electrooptic light valve panel (12) for use in viewing the panel in dark conditions with night vision equipment whilst the means (18) for emitting relatively high intensity light is deactivated by deenergising the light source means (18), characterised in that the first means are disposed in a zone extending from a rear surface of the panel, the second means are disposed outside that zone, so as not to be interposed between portions of the first means nor between the first means and the panel, and being arranged to direct the relatively low intensity light to the panel via said zone through diffusing portions of the first means (18) in said zone to diffuse that light before that low intensity light reaches the panel.
4. A device according to claim 2 or 3, wherein the light source means (18) comprises at least one primary lighting source means (18) and the second means are arranged behind the light source means (18) to direct their light to the panel via the lighting source means which serves to diffuse the light of the second means.
5. A device according to claim 1, 2, 3 or 4 and comprising a reflecting surface (20) defining a boundary of said zone at that side of the first light emitting means (18) opposite the placement of the electrooptic modulated light valve panel (12) whereby light from said first light emitting means (18) is reflected through said electrooptic modulated light valve panel (12).
6. A device according to claim 5, wherein the reflecting surface (20) contains through apertures (23).
7. A device according to claim 6, wherein the second light emitting means are arranged to emit light through said apertures (23) to the panel (12).
8. A device according to claim 7, when appended to claim 1, wherein said filter means (39) are placed between the second light emitting means (37) and said apertures (23).
9. A device according to claim 5, 6 or 7, wherein the second light emitting means (22) are embedded within the material defining said reflecting surface (20).
10. A device according to any one of the preceding

claims, wherein the directing means comprises a light guide (82) and the second means are arranged to direct the relatively low intensity light through one side of the light guide.

11. A device according to claim 10 wherein the light guide comprises a side illuminated, internally reflecting, light pipe or guide (82).
12. A device according to any one of the preceding claims wherein the first means (18) for emitting relatively high intensity light comprises at least one primary, fluorescent, lighting means.
13. A device according to claim 12, wherein said first means for emitting relatively high intensity light comprises a flat fluorescent lamp (52).
14. A device according to any one of the preceding claims wherein the first means comprises a diffusing means (16) placed between the lighting source of the first means (18) and the light valve panel (12).
15. A device according to any one of claims 1 to 13 wherein the first means comprises a filter means placed between the lighting source of the first lighting means (18) and the light valve panel (12).
16. A device according to any one of the preceding claims comprising at least one secondary, fluorescent, lighting means (37) as the means for emitting relatively low intensity light and which is arranged to transmit light through the deactivated means (18, 20) for emitting relatively high intensity light.
17. A device according to any one of claims 1 to 15, wherein the second means comprises multiple light emitting sources (22).
18. A device according to claim 17 when appended to claim 2 or 3, wherein said sources are associated with optical lenses which aid in focusing the emitted low-level light into the first means (18).
19. A device according to claim 17 or 18, wherein the sources (38) are associated with filters (36) to controllably reduce the relatively low intensity light emitted to a preselected level suitable for viewing the panel display (12) in the dark with night vision equipment.
20. A device according to any one of claims 17 to 19, wherein said sources are an array of light emitting diodes.
21. A device according to any one of claims 17 to 19, wherein said sources comprise an array of miniature incandescent lamps.

22. A device according to any one of the preceding claims wherein said panel (12) is a liquid crystal panel.

5 23. A device according to any one of the preceding claims and arranged so as to be operable to define readable coloured patterns of information at the panel.

10 24. A device according to any one of the preceding claims, wherein the second means are arranged to emit light substantially excluding the infrared region.

15

Patentansprüche

1. Anzeigevorrichtung mit Hinterlicht und elektrooptisch moduliertem Lichtdurchlass, umfassend

20

eine elektrooptische Lichtdurchlassplatte (12), die Licht, das durch die Platte hindurchgeht, in steuerbarer Weise zu Informationsmustern verändert;

25

erste Einrichtungen (18), die ein Licht vergleichsweise hoher Intensität abgeben, wobei die ersten Einrichtungen eine elektrisch erregte Lichtquelleneinrichtung (18) enthalten sowie Einrichtungen (16, 20) zum Lenken des in der Lichtquelleneinrichtung erzeugten Lichts auf und durch eine rückwärtige Fläche der elektrooptischen Lichtdurchlassplatte (12) hindurch, wobei die Intensität ausreicht, dass man die Anzeige bei Tageslicht sehen kann;

30

zweite Einrichtungen (37), die durch die elektrooptische Lichtdurchlassplatte (12) hindurch ein Licht vergleichsweise geringer Stärke abgeben, so dass man unter dunklen Bedingungen die Platte mit einer Nachtsichtausrüstung sehen kann, während die Einrichtung (18) zum Aussenden von Licht vergleichsweise hoher Stärke deaktiviert ist, indem die Lichtquelleneinrichtung (18) nicht mehr erregt wird, dadurch gekennzeichnet,

35

dass die ersten Einrichtungen in einem Bereich angeordnet sind, der von der rückwärtigen Fläche der Platte vorsteht,

40

dass die zweiten Einrichtungen außerhalb dieses Bereichs angeordnet sind, so dass sie weder zwischen Teilen der ersten Einrichtungen angeordnet sind noch zwischen den ersten Einrichtungen und der Platte, sondern so eingerichtet sind, dass sie das Licht vergleichsweise geringer Intensität durch den Bereich auf die Platte lenken, und

45

dass Infrarot-Filtervorrichtungen vorhanden sind, die das Licht der zweiten Einrichtungen, bevor oder wenn es in den Bereich eintritt, fil-

50

55

tern.

2. Vorrichtung nach Anspruch 1, wobei die zweiten Einrichtungen (37) so angeordnet sind, dass sie das Licht, bevor es die Platte erreicht, in den Bereich und durch Diffusorabschnitte (18) der ersten Einrichtungen lenken.

3. Anzeigevorrichtung mit Hinterlicht und elektrooptisch moduliertem Lichtdurchlass, umfassend

eine elektrooptische Lichtdurchlassplatte (12), die das Licht, das die Platte durchdringt, in steuerbarer Weise zu Informationsmustern verändert,

erste Einrichtungen (18), die Licht vergleichsweise hoher Intensität aussenden, wobei die ersten Einrichtungen eine elektrisch erregte Lichtquelleneinrichtung (18) enthalten sowie Vorrichtungen zum Lenken des in der Lichtquelleneinrichtung erzeugten Lichts auf und durch eine rückwärtige Fläche der elektrooptischen Lichtdurchlassplatte hindurch, und die Intensität für die Betrachtung der Anzeige bei Tageslicht ausreicht,

zweite Einrichtungen (37) zum Aussenden von Licht relativ geringer Intensität durch die elektrooptische Lichtdurchlassplatte (12), damit man die Platte in der Dunkelheit mit einer Nachtsichtausrüstung betrachten kann, während die Einrichtung (18) zum Aussenden des relativ hochintensiven Lichts dadurch abgeschaltet wird, dass die Lichtquelleneinrichtung (18) nicht mehr erregt wird, dadurch gekennzeichnet,

dass die ersten Einrichtungen in einem Bereich angeordnet sind, der von der rückwärtigen Fläche der Platte vorsteht,

dass die zweiten Einrichtungen außerhalb dieses Bereichs angeordnet sind, so dass sie weder zwischen Teilen der ersten Einrichtungen angeordnet sind noch zwischen den ersten Einrichtungen und der Platte, sondern so eingerichtet sind, dass sie das Licht relativ geringer Intensität über den Bereich zur Platte lenken, und zwar durch Diffusorabschnitte der ersten Einrichtungen (18) in dem Bereich, um das Licht zu streuen, bevor das Licht geringer Intensität die Platte erreicht.

4. Vorrichtung nach Anspruch 2 oder 3, wobei die Lichtquelleneinrichtung (18) zumindest eine primäre Lichtquellen-Einrichtung (18) besitzt und die zweiten Einrichtungen hinter der Lichtquelleneinrichtung (18) angeordnet sind, um ihr Licht über die Lichtquelleneinrichtung, die zum Streuen des Lichts der zweiten Einrichtungen dient, zur Platte zu lenken.

5. Vorrichtung nach Anspruch 1, 2, 3 oder 4, zudem umfassend eine reflektierende Oberfläche (20), die eine Grenze des Bereichs an der Seite der ersten lichtaussendenden Einrichtungen (18) bestimmt und gegenüber der elektrooptisch modulierten Lichtdurchlassplatte (12) angeordnet ist, wobei die elektrooptisch modulierte Lichtdurchlassplatte (12) Licht aus den ersten lichtaussendenden Einrichtungen (18) reflektiert.

6. Vorrichtung nach Anspruch 5, wobei die reflektierende Oberfläche (20) Durchgangsöffnungen (23) enthält.

7. Vorrichtung nach Anspruch 6, wobei die zweiten lichtaussendenden Einrichtungen so gestaltet sind, dass sie Licht durch die Öffnungen (23) zur Platte (12) senden.

8. Vorrichtung nach Anspruch 7, wenn abhängig von Anspruch 1, wobei die Filtervorrichtungen (39) zwischen den zweiten lichtaussendenden Einrichtungen (37) und den Öffnungen (23) angeordnet sind.

9. Vorrichtung nach Anspruch 5, 6 oder 7, wobei die zweiten lichtaussendenden Einrichtungen (22) in dem Material eingebettet sind, das die reflektierende Oberfläche (20) bestimmt.

10. Vorrichtung nach irgendeinem der vorhergehenden Ansprüche, wobei die Lenkvorrichtung eine Lichtführung (82) enthält und die zweiten Einrichtungen so gestaltet sind, dass sie das Licht relativ geringer Intensität durch eine Seite der Lichtführung lenken.

11. Vorrichtung nach Anspruch 10, wobei die Lichtführung einen seitlich beleuchteten und innen reflektierenden Lichtleiter oder eine Führung (82) enthält.

12. Vorrichtung nach irgendeinem der vorhergehenden Ansprüche, wobei die erste Einrichtung (18) zum Aussenden von Licht vergleichsweise hoher Intensität zumindest eine primäre Fluoreszenz-Beleuchtungseinrichtung umfasst.

13. Vorrichtung nach Anspruch 12, wobei die erste Einrichtung zum Aussenden relativ hochintensiven Lichts eine ebene Fluoreszenzlampe (52) enthält.

14. Vorrichtung nach irgendeinem der vorhergehenden Ansprüche, wobei die erste Einrichtung eine Diffusorvorrichtung (16) enthält, die zwischen der Lichtquelle der ersten Einrichtungen (18) und der Lichtdurchlassplatte (12) angeordnet ist.

15. Vorrichtung nach irgendeinem der Ansprüche 1 bis 13, wobei die erste Einrichtung eine Filtervorrichtung

tung umfasst, die zwischen der Lichtquelle der ersten Beleuchtungseinrichtungen (18) und der Lichtdurchlassplatte (12) angeordnet ist.

16. Vorrichtung nach irgendeinem der vorhergehenden Ansprüche, umfassend zumindest eine sekundäre Fluoreszenz-Beleuchtungseinrichtung (37) als Einrichtung zum Aussenden von Licht relativ geringer Intensität, die so eingerichtet ist, dass sie Licht durch die abgeschaltete Einrichtung (18, 20) zum Aussenden von relativ hochintensivem Licht sendet. 5 10
17. Vorrichtung nach irgendeinem der Ansprüche 1 bis 15, wobei die zweite Einrichtung eine Anzahl lichtaussendender Quellen (22) enthält. 15
18. Vorrichtung nach Anspruch 17, wenn abhängig von Anspruch 2 oder 3, wobei die Quellen optischen Linsen zugeordnet sind, die das Fokussieren des abgegebenen schwachen Lichts auf die ersten Einrichtungen (18) unterstützen. 20
19. Vorrichtung nach Anspruch 17 oder 18, wobei den Quellen (38) Filter (36) zugeordnet sind, damit das abgegebene Licht relativ geringer Intensität gesteuert auf einen vorgewählten Pegel abgeschwächt werden kann, der sich zum Betrachten der Plattenanzeige (12) im Dunkeln mit einer Nachtsichtausrüstung eignet. 25 30
20. Vorrichtung nach irgendeinem der Ansprüche 17 bis 19, wobei die Quellen ein Leuchtdiodenfeld sind. 35
21. Vorrichtung nach irgendeinem der Ansprüche 17 bis 19, wobei die Quellen ein Feld aus Miniglühlampen enthalten. 40
22. Vorrichtung nach irgendeinem der vorhergehenden Ansprüche, wobei die Platte (12) eine Flüssigkristallplatte ist. 45
23. Vorrichtung nach irgendeinem der vorhergehenden Ansprüche, so eingerichtet, dass sie zum Bestimmen lesbarer farbiger Informationsmuster auf der Platte betreibbar ist. 50
24. Vorrichtung nach irgendeinem der vorhergehenden Ansprüche, wobei die zweiten Einrichtungen so gestaltet sind, dass sie Licht im wesentlichen außerhalb des Infrarotbereichs abgeben. 55

Revendications

1. Dispositif d'affichage à éclairage par l'arrière à modulateur électro-optique de lumière qui comprend :

un écran (12) à modulateur électro-optique de lumière destiné à modifier de façon maîtrisée la lumière qui le traverse pour former des motifs d'information, un premier moyen (18) destiné à émettre de la lumière de relativement forte intensité, le premier moyen comprenant un moyen (18) formant source de lumière alimenté par de l'électricité et un moyen (16, 20) destiné à diriger la lumière produite par le moyen formant source de lumière sur une face arrière dudit écran (12) à modulateur électro-optique de lumière, et à travers celui-ci, et avec une intensité suffisante pour voir l'afficheur à la lumière du jour ; et un second moyen (37) destiné à émettre une lumière d'intensité relativement faible à travers ledit écran (12) à modulateur électro-optique de lumière servant à voir l'écran dans des conditions d'obscurité à l'aide d'un équipement de vision nocturne, tandis que le moyen (18) destiné à émettre de la lumière d'intensité relativement forte est désactivé par coupure de l'alimentation du moyen (18) formant source de lumière, caractérisé en ce que le premier moyen est disposé dans une zone s'étendant depuis la face arrière de l'écran, en ce que le second moyen est disposé à l'extérieur de cette zone, de façon à n'être pas interposé entre des parties du premier moyen ni entre le premier moyen et l'écran, et étant agencé pour diriger la lumière d'intensité relativement faible sur l'écran en passant par ladite zone, et en ce qu'il y a un moyen formant filtre à infrarouge destiné à filtrer la lumière provenant du second moyen avant ou lorsqu'elle entre dans ladite zone.

2. Dispositif selon la revendication 1, dans lequel le second moyen (37) est agencé pour diriger de la lumière dans ladite zone et à travers des parties diffusantes (18) du premier moyen avant que la lumière atteigne l'écran.

3. Dispositif d'affichage à éclairage par l'arrière à modulateur électro-optique de lumière qui comprend : un écran (12) à modulateur électro-optique de lumière destiné à modifier de façon maîtrisée la lumière qui le traverse pour former des motifs d'information ; un premier moyen (18) destiné à émettre de la lumière de relativement forte intensité, le premier moyen comprenant un moyen (18) formant source de lumière alimenté par de l'électricité et un moyen destiné à diriger la lumière produite par le moyen formant source de lumière sur une face arrière dudit écran à modulateur électro-optique de lumière, et à travers celui-ci, et avec une intensité suffisante pour voir l'afficheur à la lumière du jour ; et un second moyen (37) destiné à émettre une lumière d'intensité relativement faible à travers ledit écran (12) à modulateur électro-optique de lumière servant à voir l'écran dans des conditions d'obscurité à l'aide d'un équipement de vision nocturne, tan-

- dis que le moyen (18) destiné à émettre de la lumière d'intensité relativement forte est désactivé par coupure de l'alimentation du moyen (18) formant source de lumière, caractérisé en ce que le premier moyen est disposé dans une zone s'étendant depuis la face arrière de l'écran, en ce que le second moyen est disposé à l'extérieur de cette zone, de façon à n'être pas interposé entre des parties du premier moyen ni entre le premier moyen et l'écran, et étant agencé pour diriger la lumière d'intensité relativement faible sur l'écran en passant par ladite zone à travers des parties diffusantes du premier moyen (18) dans ladite zone pour diffuser cette lumière avant que la lumière de faible intensité atteigne l'écran.
4. Dispositif selon la revendication 2 ou 3, dans lequel le moyen (18) formant source de lumière comprend au moins un moyen primaire (18) formant source de lumière et dans lequel le second moyen est agencé derrière le moyen (18) formant source de lumière pour diriger sa lumière sur l'écran en passant par le moyen formant source de lumière qui sert à diffuser la lumière du second moyen.
 5. Dispositif selon la revendication 1, 2, 3 ou 4 et comprenant une surface réfléchissante (20) définissant une frontière de ladite zone du côté du premier moyen (18) émetteur de lumière opposé à l'emplacement de l'écran (12) à modulateur électro-optique de lumière, en réfléchissant ainsi la lumière issue du premier moyen (18) émetteur de lumière à travers ledit écran (12) à modulateur électro-optique de lumière.
 6. Dispositif selon la revendication 5, dans lequel la surface réfléchissante (20) contient des ouvertures traversantes (23).
 7. Dispositif selon la revendication 6, dans lequel le second moyen émetteur de lumière est agencé pour émettre de la lumière à travers lesdites ouvertures (23) vers l'écran (12).
 8. Dispositif selon la revendication 7, lorsqu'elle dépend de la revendication 1, dans lequel ledit moyen (39) formant filtre est placé entre le second moyen (37) émetteur de lumière et lesdites ouvertures (23).
 9. Dispositif selon la revendication 5, 6 ou 7, dans lequel le second moyen (22) émetteur de lumière est incorporé à l'intérieur de la matière formant ladite surface réfléchissante (20).
 10. Dispositif selon l'une quelconque des revendications précédentes, dans lequel le moyen de direction comprend un guide (82) de lumière et le second moyen est agencé pour diriger la lumière de relativement faible intensité à travers un côté du guide de lumière.
 - 5 11. Dispositif selon la revendication 10, dans lequel le guide de lumière comprend un tube ou guide (82) de lumière, éclairé latéralement, à réflexion interne.
 - 10 12. Dispositif selon l'une quelconque des revendications précédentes, dans lequel le premier moyen (18) destiné à émettre de la lumière de relativement forte intensité comprend au moins un moyen primaire d'éclairage, fluorescent.
 - 15 13. Dispositif selon la revendication 12, dans lequel ledit premier moyen destiné à émettre de la lumière de relativement forte intensité comprend une lampe fluorescente plate (52).
 - 20 14. Dispositif selon l'une quelconque des revendications précédentes, dans lequel le premier moyen comprend un moyen diffusant (16) placé entre la source de lumière du premier moyen (18) et l'écran (12) à modulateur de lumière.
 - 25 15. Dispositif selon l'une quelconque des revendications 1 à 13, dans lequel le premier moyen comprend un moyen formant filtre placé entre la source de lumière du premier moyen d'éclairage (18) et l'écran (12) à modulateur de lumière.
 - 30 16. Dispositif selon l'une quelconque des revendications précédentes comprenant au moins un moyen secondaire (37) d'éclairage fluorescent en tant que moyen destiné à émettre de la lumière de relativement faible intensité et qui est agencé pour transmettre de la lumière à travers le moyen (18, 20) désactivé, destiné à émettre de la lumière de relativement forte intensité.
 - 35 17. Dispositif selon l'un quelconque des revendications 1 à 15, dans lequel le second moyen comprend de multiples sources (22) émettrices de lumière.
 - 40 18. Dispositif selon la revendication 17, lorsqu'elle dépend de la revendication 2 ou 3, dans lequel lesdites sources sont associées à des lentilles optiques qui aident à focaliser, dans le premier moyen (18), la lumière de faible niveau émise.
 - 50 19. Dispositif selon les revendications 17 ou 18, dans lequel les sources (38) sont associées à des filtres (36) pour réduire de façon maîtrisée la lumière de relativement faible intensité émise à un niveau choisi préalablement, approprié pour voir l'afficheur (12) à écran dans l'obscurité à l'aide d'un équipement de vision nocturne.
 - 55

- 20.** Dispositif selon les revendications 17 à 19, dans lequel lesdites sources sont un groupement de diodes émettrices de lumière.
- 21.** Dispositif selon les revendications 17 à 19, dans lequel lesdites sources comprennent un groupement de lampes à incandescence miniatures. 5
- 22.** Dispositif selon l'une quelconque des revendications précédentes, dans lequel ledit écran (12) est un écran à cristaux liquides. 10
- 23.** Dispositif selon l'une quelconque des revendications précédentes, et agencé de façon à pouvoir être mis en oeuvre pour définir, sur l'écran, des motifs colorés, lisibles, d'information. 15
- 24.** Dispositif selon l'une quelconque des revendications précédentes, dans lequel le second moyen est agencé pour émettre de la lumière excluant sensiblement la région de l'infrarouge. 20

25

30

35

40

45

50

55

FIG. 1

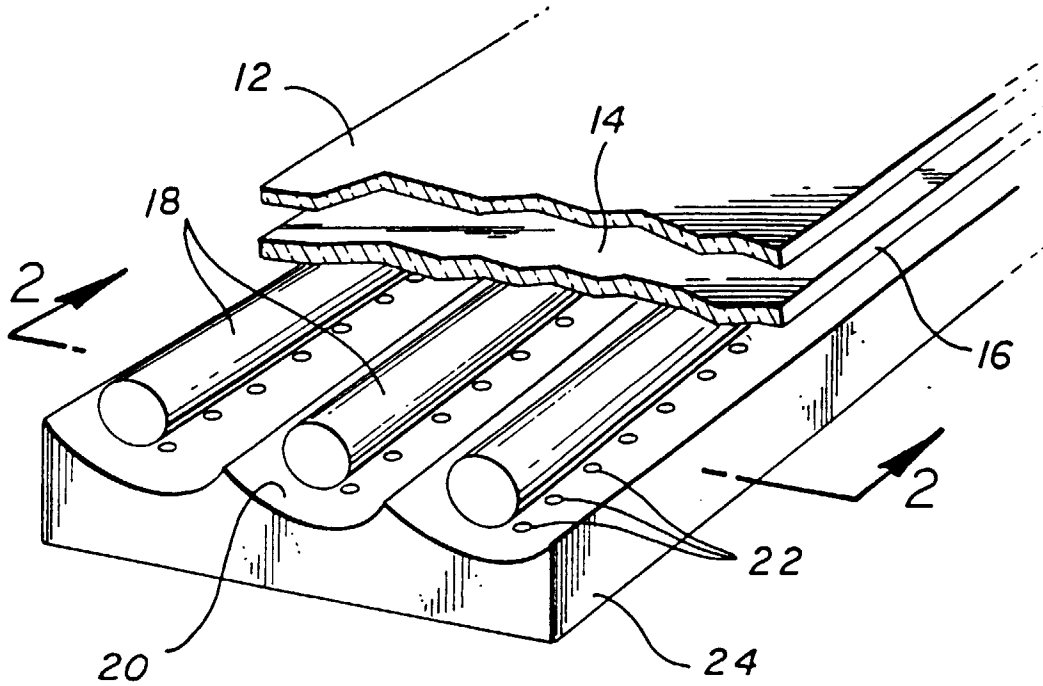

FIG. 2

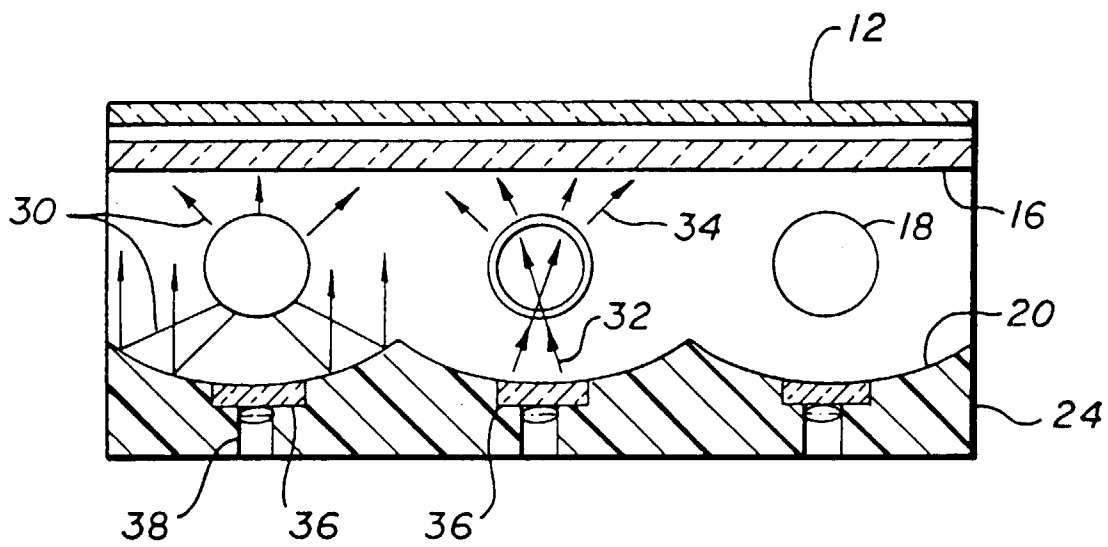

FIG. 3

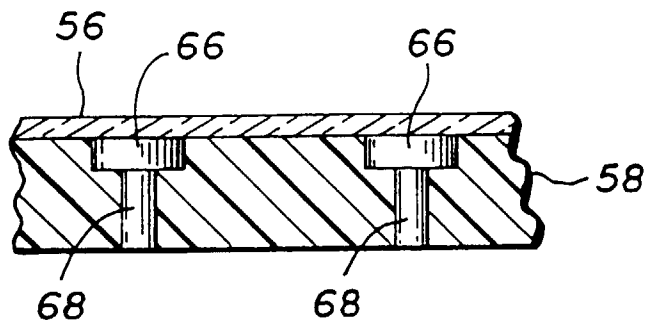
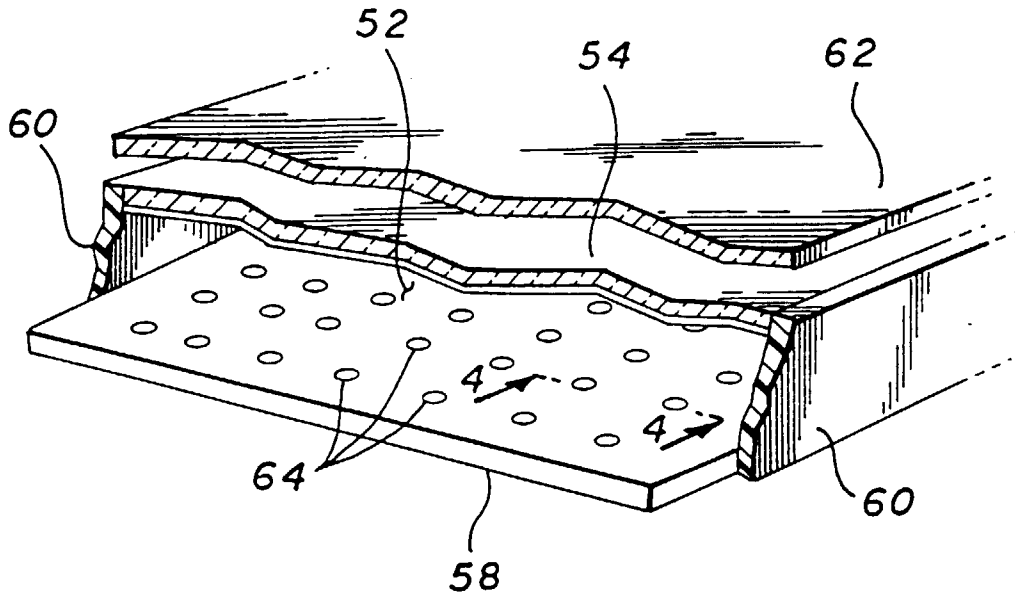

FIG. 4

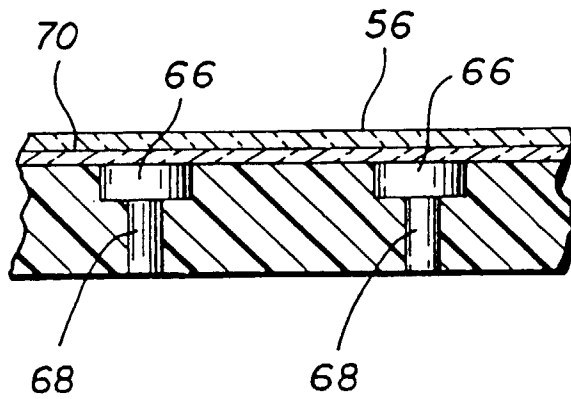

FIG. 5

FIG. 6

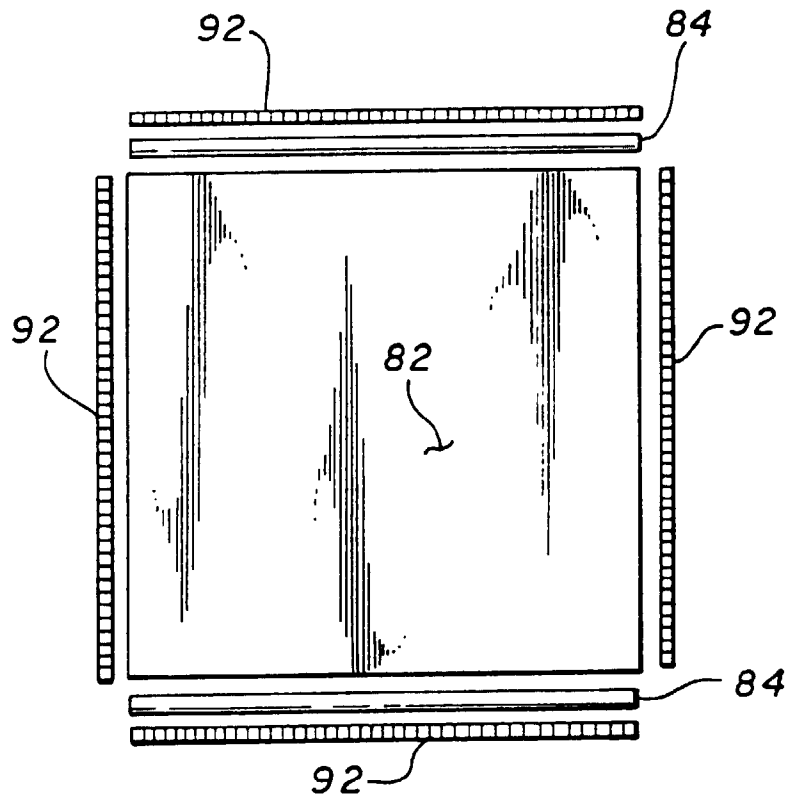
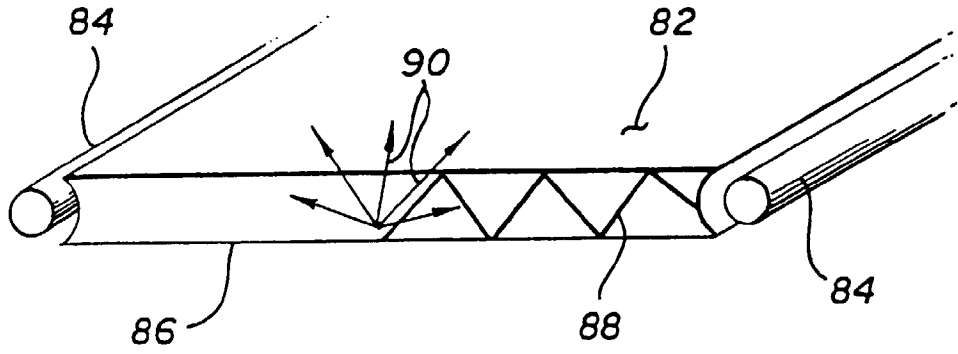

FIG. 7

FIG. 8

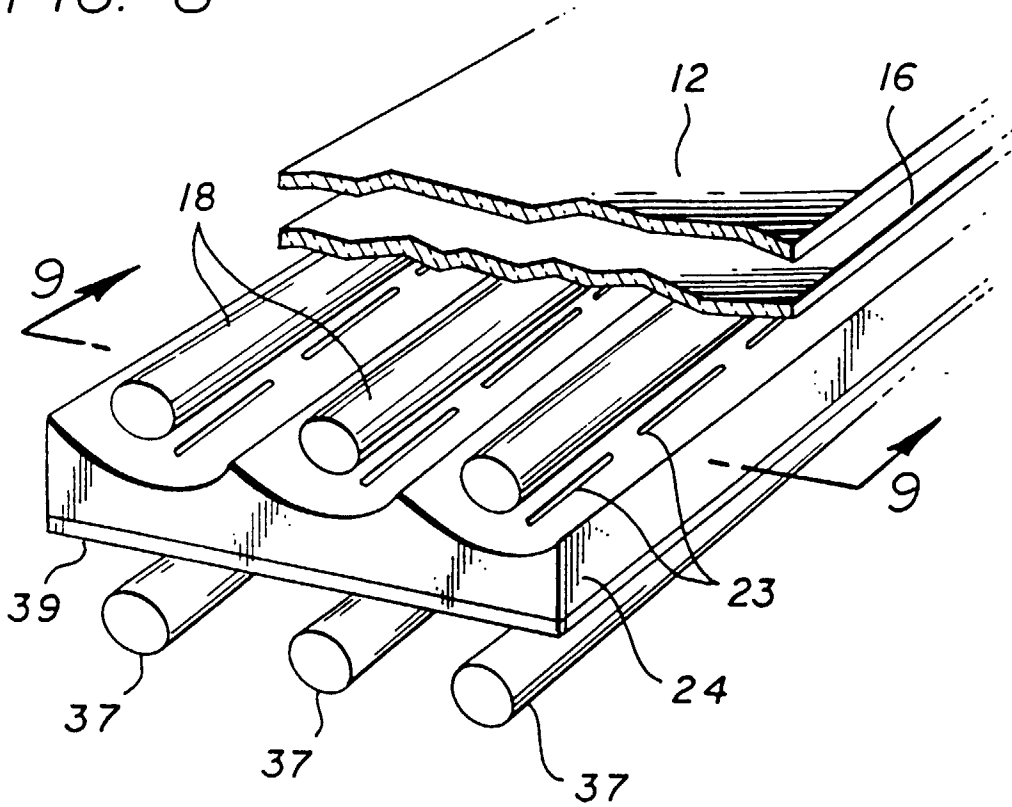

FIG. 9

