



(12) **EUROPEAN PATENT APPLICATION**

(43) Date of publication: **03.11.2004 Bulletin 2004/45** (51) Int Cl.7: **G03F 7/20**

(21) Application number: **04250743.4**

(22) Date of filing: **11.02.2004**

(84) Designated Contracting States:  
**AT BE BG CH CY CZ DE DK EE ES FI FR GB GR  
HU IE IT LI LU MC NL PT RO SE SI SK TR**  
Designated Extension States:  
**AL LT LV MK**

(72) Inventor: **Hansen, Steven George  
Phoenix, Arizona 85048 (US)**

(74) Representative: **Leeming, John Gerard  
J.A. Kemp & Co.,  
14 South Square,  
Gray's Inn  
London WC1R 5JJ (GB)**

(30) Priority: **11.02.2003 US 361831  
20.11.2003 US 716439**

(71) Applicant: **ASML Netherlands B.V.  
5504 DR Veldhoven (NL)**

Remarks:

The references to figures 43-59 are deemed to be deleted (Rule 43 EPC).

(54) **Lithographic apparatus and method for optimizing an illumination source using photolithographic simulations**

(57) A method for optimizing the illumination conditions of a lithographic apparatus by computer simulation, the lithographic apparatus including an illuminator and a projection system, includes defining a lithographic pattern to be printed on the substrate, selecting a simulation model, selecting a grid of source points in a pupil

plane of the illuminator, calculating separate responses for individual source points, each of the responses representing a result of a single or series of simulations using the simulation model, and adjusting an illumination arrangement based on analysis of accumulated results of the separate calculations.

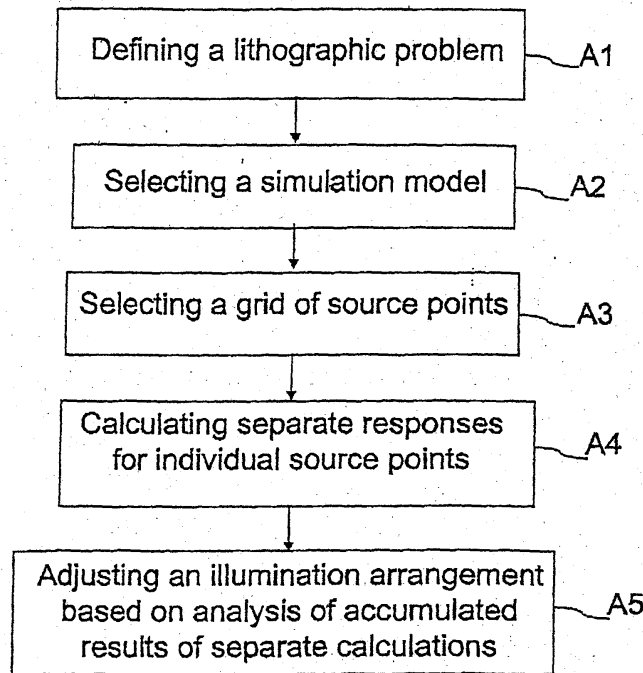

FIG. 13

## Description

**[0001]** The present invention relates to a method for optimizing an illumination source of a lithographic apparatus. More specifically, the invention relates to a method for optimizing an illumination source using computer simulation.

**[0002]** The term "patterning structure" as here employed should be broadly interpreted as referring to a device that can be used to endow an incoming radiation beam with a patterned cross-section, corresponding to a pattern that is to be created in a target portion of the substrate. The term "light valve" can also be used in this context. Generally, the pattern will correspond to a particular functional layer in a device being created in the target portion, such as an integrated circuit or other device. An example of such a patterning structure is a mask. The concept of a mask is well known in lithography, and it includes mask types such as binary, alternating phase shift, and attenuated phase shift, as well as various hybrid mask types. Placement of such a mask in the radiation beam causes selective transmission (in the case of a transmissive mask) or reflection (in the case of a reflective mask) of the radiation impinging on the mask, according to the pattern on the mask. In the case of a mask, the support structure will generally be a mask table, which ensures that the mask can be held at a desired position in the incoming radiation beam, and that it can be moved relative to the beam if so desired.

**[0003]** Another example of a patterning structure is a programmable mirror array. One example of such an array is a matrix-addressable surface having a viscoelastic control layer and a reflective surface. The basic principle behind such an apparatus is that, for example, addressed areas of the reflective surface reflect incident light as diffracted light, whereas unaddressed areas reflect incident light as undiffracted light. Using an appropriate filter, the undiffracted light can be filtered out of the reflected beam, leaving only the diffracted light behind. In this manner, the beam becomes patterned according to the addressing pattern of the matrix addressable surface. An alternative embodiment of a programmable mirror array employs a matrix arrangement of tiny mirrors, each of which can be individually tilted about an axis by applying a suitable localized electric field, or by employing piezoelectric actuators. Once again, the mirrors are matrix addressable, such that addressed mirrors will reflect an incoming radiation beam in a different direction to unaddressed mirrors. In this manner, the reflected beam is patterned according to the addressing pattern of the matrix-addressable mirrors. The required matrix addressing can be performed using suitable electronics. In both of the situations described hereabove, the patterning structure can include one or more programmable mirror arrays. More information on mirror arrays as here referred to can be seen, for example, from United States Patents U.S. 5,296,891 and 5,523,193, and PCT publications WO 98/38597 and WO 98/33096.

In the case of a programmable mirror array, the support structure may be embodied as a frame or table, for example, which may be fixed or movable as required.

**[0004]** Another example of a patterning structure is a programmable LCD array. An example of such a construction is given in U. S. Patent 5,229,872. As above, the support structure in this case may be embodied as a frame or table, for example, which may be fixed or movable as required.

**[0005]** For purposes of simplicity, the rest of this text may, at certain locations, specifically direct itself to examples involving a mask and mask table. However, the general principles discussed in such instances should be seen in the broader context of the patterning structure as hereabove set forth.

**[0006]** Lithographic projection apparatus can be used, for example, in the manufacture of integrated circuits (ICs). In such a case, the patterning structure may generate a circuit pattern corresponding to an individual layer of the IC, and this pattern can be imaged onto a target portion (e.g. including one or more dies on a substrate (silicon wafer) that has been coated with a layer of radiation sensitive material (resist). In general, a single wafer will contain a whole network of adjacent target portions that are successively irradiated via the projection system, one at a time. In current apparatuses, employing patterning by a mask on a mask table, a distinction can be made between two different types of machines. In one type of lithographic projection apparatus, each target portion is irradiated by exposing the entire mask pattern onto the target portion at once. Such an apparatus is commonly referred to as a wafer stepper. In an alternative apparatus, commonly referred to as a step and scan apparatus, each target portion is irradiated by progressively scanning the mask pattern under the projection beam in a given reference direction (the "scanning" direction) while synchronously scanning the substrate table parallel or anti-parallel to this direction. Since, in general, the projection system will have a magnification factor  $M$  (generally  $< 1$ ), the speed  $V$  at which the substrate table is scanned will be a factor  $M$  times that at which the mask table is scanned. More information with regard to lithographic devices as here described can be seen, for example, from U.S. Patent 6,046,792.

**[0007]** In a known manufacturing process using a lithographic projection apparatus, a pattern (e.g. in a mask) is imaged onto a substrate that is at least partially covered by a layer of radiation sensitive material (resist). Prior to this imaging, the substrate may undergo various procedures, such as priming, resist coating and a soft bake. After exposure, the substrate may be subjected to other procedures, such as a post-exposure bake (PEB), development, a hard bake and measurement and/or inspection of the imaged features. This array of procedures is used as a basis to pattern an individual layer of a device, e.g. an IC. Such a patterned layer may then undergo various processes such as etching, ion-

implantation (doping), metallization, oxidation, chemical, mechanical polishing, etc., all intended to finish off an individual layer. If several layers are required, then the whole procedure, or a variant thereof, will have to be repeated for each new layer. It is important to ensure that the overlay (juxtaposition) of the various stacked layers is as accurate as possible. For this purpose, a small reference mark is provided at one or more positions on the wafer, thus defining the origin of a coordinate system on the wafer. Using optical and electronic devices in combination with the substrate holder positioning device (referred to hereinafter as "alignment system"), this mark can then be relocated each time a new layer has to be juxtaposed on an existing layer, and can be used as an alignment reference. Eventually, an array of devices will be present on the substrate (wafer). These devices are then separated from one another by a technique such as dicing or sawing, whence the individual devices can be mounted on a carrier, connected to pins, etc. Further information regarding such processes can be obtained, for example, from the book "Microchip Fabrication: A Practical Guide to Semiconductor Processing", Third Edition, by Peter van Zant, McGraw Hill Publishing Co., 1997, ISBN 0-07-067250-4.

**[0008]** For the sake of simplicity, the projection system may hereinafter be referred to as the "lens." However, this term should be broadly interpreted as encompassing various types of projection systems, including refractive optics, reflective optics, and catadioptric systems, for example. The radiation system may also include components operating according to any of these design types for directing, shaping or controlling the projection beam of radiation, and such components may also be referred to below, collectively or singularly, as a "lens." Further, the lithographic apparatus may be of a type having two or more substrate tables (and/or two or more mask tables). In such "multiple stage" devices the additional tables may be used in parallel or preparatory steps may be carried out on one or more tables while one or more other tables are being used for exposures. Dual stage lithographic apparatuses are described, for example, in U.S. Patents 5,969,441 and 6,262,796.

**[0009]** Photolithography is widely recognized as one of the key steps in the manufacturing of integrated semiconductor circuits. At present, no alternative technology provides the desired pattern architecture with similar accuracy, speed, and economic productivity. However, as the dimensions of the ICs become smaller, photolithography is becoming one of the most, if not the most, critical gating factors for enabling miniature semiconductor device structures to be manufactured on a truly massive scale.

**[0010]** A theoretical estimate of the limits of pattern printing can be given by the Rayleigh criterion for resolution  $R$  as shown in equation (1):

$$R = k_i * \frac{\lambda}{NA} \quad (1)$$

where  $\lambda$  is the wavelength of the radiation used,  $NA$  is the numerical aperture of the lens in the projection system and  $k_1$  is a process dependent adjustment factor.

**[0011]** It follows from equation (1) that the resolution can be improved in three ways: by shortening the exposure wavelength  $\lambda$ , by increasing the numerical aperture  $NA$  or by decreasing the value of  $k_1$ . All of these strategies have been pursued simultaneously in the past and are expected to continue in the future.

**[0012]** The performance of the lithographic apparatus and its limitation may also be explained and characterized with the Depth Of Focus (DOF), which is generally viewed as one of the most critical factors in determining the resolution of the lithographic projection apparatus.

The DOF, defined in equation (2), is defined as the distance along the optical axis over which the image of the pattern is adequately sharp.

$$DOF = +/-k_2 * \frac{\lambda}{NA^2} \quad (2)$$

where  $k_2$  is an empirical constant.

**[0013]** Additional important responses/measures that provide more insight into the real difficulties associated with photolithography at the resolution limit include the Exposure Latitude (EL), the Dense Isolated Bias (DIB), and the Mask Error Enhancement Factor (MEEF). The Exposure Latitude describes the percentage dose range where the printed pattern's critical dimension (CD) is acceptable, typically 10%. It is used along with the DOF to determine the process window, i.e. the regions of focus and exposure that keep the final resist profile within prescribed specifications. As for the DIB, it is a measure of the size difference between similar features, depending on the pattern density. Finally, the MEEF describes how reticle CD errors are transmitted into wafer CD errors.

**[0014]** As the semiconductor industry moves into the deep submicron regime, the resolution limit of currently available lithographic techniques is being reached due to a decrease in the depth of focus, difficulty in the design of lenses and complexities in the lens fabrication technology. In order to address this issue, there have been continued endeavors to develop resolution enhancement techniques.

**[0015]** Historically, the resolution limit of a lithographic projection tool was optimized by the control of the relative size of the illumination system numerical aperture (NA). Control of this NA with respect to the projection system's objective lens NA allows for modification of spatial coherence at the mask plane, commonly referred to as partial coherence  $s$ . This is accomplished through specification of the condenser lens pupil in a Köhler illumination system. Essentially, this allows for manipulation of the optical processing of diffraction information. Optimization of the partial coherence of a projection imaging system is conventionally accomplished using full

circular illuminator apertures. By controlling the distribution of diffraction information in the objective lens with the illuminator pupil size, maximum image modulation can be obtained. Illumination systems can be further refined by considering variations to full circular illumination apertures. A system where illumination is obliquely incident on the mask at an angle so that the zero-th and first diffraction orders are distributed on alternative sides of the optical axis may allow for improvements. Such an approach is generally referred to as off-axis illumination.

**[0016]** Off-axis illumination improves resolution by illuminating the mask with radiation that is at an angle to the optical axis of the lens. The incidence of the radiation on the mask, which acts as a diffraction grating, improves the contrast of the image by transmitting more of the diffracted orders through the lens. Off-axis illumination techniques used with conventional masks produce resolution enhancement effects similar to resolution enhancement effects obtained with phase shifting masks.

**[0017]** Various other enhancement techniques that have been developed to increase the resolution and the DOF include optical proximity correction (OPC) of optical proximity errors (OPE), phase shifting masks (PSM), and sub-resolution assist features (SRAF). Each technique may be used alone, or in combination with other techniques to enhance the resolution of the lithographic projection tool.

**[0018]** One approach to generate off-axis illumination is to incorporate a metal aperture plate filter into the fly eye lens assembly of the projection system illuminator providing oblique illumination. A pattern on such a metal plate would have four symmetrically arranged openings (zones) with sizing and spacing set to allow diffraction order overlap for specific geometry sizing and duty ratio on the photomask. Such an approach results in a significant loss in intensity available to the mask, lowering throughput and making the approach less than desirable. Additionally, the four circular openings need to be designed specifically for certain mask geometry and pitch and do not improve the performance of other geometry sizes and spacings. The previous work in this area describes such a method using either two or four openings in the aperture plate. See, for example, EP 0 500 393, U.S. Patents 5,305,054, 5,673,103, 5,638,211, EP 0 496 891 and EP 0 486 316.

**[0019]** Another approach to off-axis illumination using the four-zone configuration, which is disclosed in U.S. Patent 6,452,662 is to divide the illumination field of the projection system into beams that can be shaped to distribute off-axis illumination to the photomask. By incorporating the ability to shape off-axis illumination, throughput and flexibility of the exposure source is maintained. Additionally, this approach allows for illumination that combines off-axis and on-axis (conventional) characteristics. By doing so, the improvement to dense features that are targeted with off-axis illumination is less significant than straight off-axis illumination. The per-

formance of less dense features, however, is more optimal because of the more preferred on-axis illumination for these features. The result is a reduction in the optical proximity effect between dense and isolated features.

Optimization is less dependent on feature geometry and more universal illumination conditions can be selected.

**[0020]** Referring to FIGS. 2-5, currently available illumination intensity distributions or arrangements include small, or low, sigma (FIG. 2), annular (FIG. 3), quadrupole (FIG. 4), and quasar (FIG. 5), with the illuminated areas (hereinafter referred to as the aperture(s)) shown in cross section. The annular, quadrupole and quasar illumination techniques of FIGS. 3-5 are examples of off-axis illumination schemes.

**[0021]** Small sigma illumination is incident on the mask with approximately zero illumination angle (i.e. almost perpendicular to the mask) and produces good results with phase shifting masks to improve resolution and increase the depth of focus. Annular illumination is incident on the mask at angles that are circularly symmetrical and improves resolution and increases depth of focus while being less pattern dependent than other illumination schemes. Quadrupole and quasar illumination are incident on the mask with four main angles and provide improved resolution and increased depth of focus while being strongly pattern dependent.

**[0022]** Referring to FIGS. 6 and 7, two illumination systems are schematically illustrated. The systems illustrated in FIGS. 6 and 7 include light collecting/collimating optics 10; an axicon/zoom module 12; and light integrating and projecting optics 14. The illumination systems define an optical axis 16, a pupil plane 18, and a mask plane 20. The axicon/zoom module 12 comprises a pair of axicons 22, one concave and one convex, whose separation can be varied. The module 12 also comprises a zoom lens 24.

**[0023]** For the case of conical axicons, some examples of the illumination intensity distributions achievable at the pupil plane 18 are shown in FIG. 8. The spot size can be varied between states A and B by changing the zoom lens position. Similarly, the annularity can be changed between states A and C by varying the axicon opening (separation between the axicons).

**[0024]** To improve the illumination homogeneity, an optical integrator 26 is used. In FIG. 6 the optical integrator takes the form of a light pipe 26, such as a glass, calcium fluoride or quartz rod. A coupler 28 couples the illumination at the pupil plane 18 into the rod 26, and rod exit imaging optics 30 are also provided. In FIG. 7 a fly's eye element 32 acts as the integrator. The fly's eye element 32 is a composite lens comprising an array or honeycomb of small lenses. Further, objective lenses 34 and 36 complete the projection optics.

**[0025]** It results from the foregoing discussion that numerous options are available to the process engineer for increasing the resolution of the lithographic projection apparatus and for maximizing the process window. Yet, given the cost and time to perform experiments in

a semiconductor fabrication facility (fab), the approach that would consist of testing these options across the board to develop a robust process is simply unrealistic. As the product cycle times in the semiconductor field are relatively short, severe limitations are put on the amount of time that can be spent on research and development for each new product line or manufacturing process.

**[0026]** In response to this concern, there has been a growing interest in photolithographic simulations within the industry. Given the fact that a simulation experiment for optimizing the optical proximity correction features for a new mask test may only take one day, instead of months with experiments on wafers, simulations are viewed today as a useful tool to aid in the development and optimization of lithographic apparatuses.

**[0027]** It follows that simulations can be extremely helpful as a development tool, by quickly evaluating options, optimizing processes, and saving time and money by reducing the number of required experiments. Simulations can also aid in the research context to understand many physical phenomena that occur when pushing the limits of resolution to achieve feature size in the order of or below the wavelength of the lithographic apparatus. Finally, simulations can be a tremendous tool to extend the optical lithography to the sub-150 nm regime and to prolong the lifetimes of million dollar steppers and billion dollar fabs.

**[0028]** One aspect of the present invention is optimizing the illumination conditions of a lithographic projection apparatus by computer simulation. The present invention provides optimization of illumination conditions of various responses of a lithographic projection apparatus, including, for example, the process window (exposure/dose latitude versus depth of focus), side lobe printing and mask error enhancement factor.

**[0029]** According to this aspect of the present invention, there is provided a method for optimizing the illumination conditions of a lithographic apparatus by computer simulation, wherein the lithographic apparatus includes an illuminator and a projection system, the method including: defining a lithographic pattern to be printed on a substrate; selecting a simulation model; selecting a grid of source points in a pupil plane of the illuminator, calculating separate responses for individual source points, each of the responses representing a result of a single or series of simulations using the simulation model; and adjusting an illumination arrangement of the illuminator based on analysis of accumulated results of the separate calculations.

**[0030]** According to another aspect of the present invention, there is provided a method for optimizing the illumination conditions of a lithographic apparatus by computer simulation using full resist calculation, wherein the lithographic apparatus includes an illuminator and a projection system, the method including: defining a lithographic pattern to be printed on a substrate; selecting a resist model; selecting a grid of source points; cal-

culating separate responses for individual source points, each of the responses representing a result of a single or series of simulations using the resist model; and adjusting an illumination arrangement based on analysis of accumulated results of the separate calculations.

**[0031]** According to yet another aspect of the invention, there is provided a method for optimizing the illumination conditions of a lithographic apparatus by computer simulation using isofocal compensation, wherein the lithographic apparatus includes an illuminator and a projection system, the method including: defining a lithographic pattern to be printed on a substrate; selecting a simulation model; selecting a grid of source points in a pupil plane of the illuminator; calculating separate responses for individual source points, each of the responses representing a result of a single or series of simulations using the simulation model; calculating a metric representing variation of the separate responses for individual source points with defocus; and adjusting an illumination arrangement based on analysis of the metric.

**[0032]** According to yet another aspect of the invention, there is provided a method for optimizing the illumination conditions of a lithographic apparatus by computer simulation using aberration sensitivity, wherein the lithographic apparatus includes an illuminator and a projection system, the method including: defining a lithographic pattern to be printed on a substrate; selecting a simulation model; selecting a grid of source points in a pupil plane of the illuminator; defining at least one aberration set for the projection system; calculating separate responses for individual source points and for the at least one aberration set, each of the responses representing a result of a single or series of simulations using the simulation model; and adjusting an illumination arrangement based on analysis of accumulated results of the separate calculations.

**[0033]** According to yet another aspect of the invention, there is provided a method for optimizing the illumination conditions of a lithographic apparatus by computer simulation using mask assist features at the illuminator level, wherein the lithographic apparatus includes an illuminator and a projection system, the method including: defining a lithographic pattern to be printed on a substrate; selecting a simulation model; defining mask assist features configured to help print the lithographic pattern on the substrate; selecting a grid of source points in a pupil plane of the illuminator, calculating separate responses for individual source points with and without mask assist features, each of the responses representing a result of a single or series of simulations using the simulation model; and adjusting an illumination arrangement based on analysis of accumulated results of the separate calculations.

**[0034]** According to another aspect of the invention, there is provided a method for optimizing the illumination conditions of a lithographic apparatus by computer sim-

ulation using best CD uniformity metric, wherein the lithographic apparatus includes an illuminator and a projection system, the method including: defining a lithographic pattern to be printed on a substrate; selecting a simulation model; selecting a grid of source points in a pupil plane of the illuminator; defining a plurality of parameters and their range of variation; calculating separate responses for individual source points and for each of the plurality of parameters, each of the responses representing a result of a single or series of simulations using the simulation model; calculating a metric representing CD variation of the lithographic pattern for the plurality of parameters and for the individual source points; and adjusting an illumination arrangement based on analysis of the metric.

**[0035]** According to yet another aspect of the present invention, there is provided a lithographic projection apparatus including: an illumination system to provide a projection beam of radiation; a support structure to support a patterning structure which can be used to pattern the projection beam according to a desired pattern; a substrate table to hold a substrate; a projection system to project the patterned beam onto a target portion of the substrate; a processor to define a lithographic pattern to be printed on the substrate, select a grid of source points in a pupil plane of the illumination system, calculate separate responses for individual source points, each of the responses representing a result of a single or series of simulations using a simulation model, and calculate an optimized illumination arrangement based on analysis of the accumulated results of the separate calculations; and a selectably variable beam controller that is adapted to modify a cross-sectional intensity distribution in the projection beam exiting the illumination system in accordance with the optimized illumination arrangement calculated by the processor.

**[0036]** According to another aspect of the present invention, there is provided a machine readable medium encoded with machine executable instructions for optimizing an illumination arrangement of an illuminator according to a method including: defining a lithographic pattern to be printed on a substrate; selecting a simulation model; selecting a grid of source points in a pupil plane of the illuminator; calculating separate responses for individual source points, each of the responses representing a result of a single or series of simulations using the simulation model; and adjusting the illumination arrangement based on analysis of the accumulated results of the separate calculations.

**[0037]** According to yet another aspect of the invention, there is provided a device manufacturing method including: projecting a patterned beam of radiation onto a target portion of a layer of radiation-sensitive material on a substrate, wherein, prior to impinging the mask, a cross-sectional intensity distribution in the projection beam is optimized using a method as described above.

**[0038]** Although specific reference may be made in this text to the use of the apparatus according to the

invention in the manufacture of ICs, it should be explicitly understood that such an apparatus has many other possible applications. For example, it may be employed in the manufacture of integrated optical systems, guidance and detection patterns for magnetic domain memories, liquid crystal display panels, thin film magnetic heads, etc. It should be appreciated that, in the context of such alternative applications, any use of the terms "reticle", "wafer" or "die" in this text should be considered as being replaced by the more general terms "mask", "substrate" and "target portion", respectively.

**[0039]** In the present document, the terms "radiation" and "beam" are used to encompass all types of electromagnetic radiation, including ultraviolet radiation (e.g. with a wavelength of 365, 248, 193, 157 or 126 nm) and EUV (extreme ultra-violet radiation, e.g. having a wavelength in the range 5-20 nm), as well as particle beams, such as ion beams or electron beams.

## 20 BRIEF DESCRIPTION OF THE DRAWINGS

**[0040]** Embodiments of the invention will now be described, by way of examples only, with reference to the accompanying schematic drawings in which:

25 **[0041]** FIG. 1 is a schematic illustration of a photolithographic projection apparatus;

**[0042]** FIG. 2 is a schematic illustration of a small, or low, sigma illumination arrangement;

30 **[0043]** FIG. 3 is a schematic illustration of an annular off-axis illumination arrangement;

**[0044]** FIG. 4 is a schematic illustration of an off-axis quadrupole illumination arrangement;

**[0045]** FIG. 5 is a schematic illustration of an off-axis quasar illumination arrangement;

35 **[0046]** FIG. 6 is a schematic illustration of an illumination system;

**[0047]** FIG. 7 is a schematic illustration of another illumination system;

40 **[0048]** FIG. 8 is a schematic illustration of illumination arrangements obtainable with the illumination systems of FIGS. 6 and 7;

**[0049]** FIG. 9 is a schematic illustration of yet an illumination system;

45 **[0050]** FIG. 10a is a schematic illustration of a multipole mode generating element of the illumination system of FIG. 9;

**[0051]** FIG. 10b is a schematic illustration of a multipole mode generating element according to another exemplary embodiment of the invention;

50 **[0052]** FIG. 11 is a schematic illustration of a multipole mode generating element according to another exemplary embodiment of the invention;

**[0053]** FIG. 12 is schematic cross section illustration of another illumination system and the resulting illumination arrangements obtainable therewith;

55 **[0054]** FIG. 13 is a flowchart illustrating a method for optimizing the illumination conditions of a lithographic projection apparatus in accordance with an embodiment

of the present invention;

**[0055]** FIG. 14(a) is a schematic representation of a cross section of the illuminator with a low sigma illumination arrangement;

**[0056]** FIG. 14(b) is a schematic representation of a cross section of the illuminator with a quasar arrangement;

**[0057]** FIG. 15 is a contour map illustrating the value of the normalized aerial image log-slope (NILS) as a function of source point location for a specific lithographic pattern (65 nm isolated lines printed with a Chromeless Phase Lithography mask);

**[0058]** FIG. 16 is a flowchart illustrating a method for optimizing the conditions of illumination of a lithographic projection apparatus according to an embodiment of the invention;

**[0059]** FIG. 17 is a contour map obtained with the method described in FIG. 16;

**[0060]** FIG. 18 is a flowchart illustrating a method for optimizing the conditions of illumination according to an embodiment of the invention;

**[0061]** FIG. 19 is a diagram comparing Depth of Focus (DOF) values simulated with various trial illumination conditions to DOF values obtained with the methods described in FIGS. 16 and 18;

**[0062]** FIG. 20 is a schematic representation of the several illumination arrangements used in FIG 19;

**[0063]** FIG. 21 is a table comparing DOF values for several illumination arrangements obtained with a commercial simulation software (Proth™) and with the embodiment of the present invention that uses weighted dose and interpolated source measurements;

**[0064]** FIG. 22 is a diagram comparing DOF values obtained with a commercial simulation software using full illuminator calculation to DOF values obtained with the methods described in FIGS. 16 and 18 for the illumination arrangements shown in FIG. 20;

**[0065]** FIG. 23 is a diagram comparing DOF values obtained with a commercial simulation software using full illuminator calculation to DOF values obtained with the methods described in FIGS. 16 and 18 for the illumination arrangements shown in FIG. 20;

**[0066]** FIG. 24 is a flowchart illustrating a method for optimizing the illumination using isofocal compensation in accordance with an embodiment of the invention;

**[0067]** FIG. 25 is a Bossung plot showing multiple CD vs. defocus curves, each curve at a different exposure;

**[0068]** FIGS. 26a and 26b represent isofocal curvature maps obtained with resist calculation and aerial image calculation;

**[0069]** FIG. 26c represents the lithographic problem studied in FIGS. 26a and 26b, corresponding to a pattern of 90 nm holes in a 360 nm pitch;

**[0070]** FIGS. 27a and 27b are isofocal curvature maps obtained with resist calculation and aerial image calculation and illustrating opposite isofocal behaviors within the illuminator;

**[0071]** FIG. 28 is a contour map showing opposite iso-

focal behavior and indicating the best illumination arrangement for the specific pattern studied (90 nm holes /360 nm pitch);

**[0072]** FIG. 29 shows the variation of the CD as a function of defocus for several exposure energies after optimization of the illumination conditions;

**[0073]** FIG. 30a is a contour map illustrating the contribution of each source point located in the illuminator to the maximum exposure latitude max-EL;

**[0074]** FIG. 30b is a contour map illustrating the contribution of each source point located in the illuminator to the dose-to-size E1:1;

**[0075]** FIG. 31 is an illumination arrangement at the pupil plane of the illuminator that combines information related to isofocal compensation, exposure latitude and dose-to-size;

**[0076]** FIG. 32 is a focus exposure matrix obtained with the illumination arrangement shown in FIG. 31;

**[0077]** FIG. 33 shows the exposure latitude obtained with the illumination arrangement shown in FIG. 31;

**[0078]** FIG. 34 shows the variation of the exposure latitude with defocus for different illumination conditions;

**[0079]** FIGS. 35a-d represent, respectively, simulation results obtained for the exposure latitude, depth of focus, depth of focus at 8% of the exposure latitude and the isofocal curvature for a pattern corresponding to 75 nm holes located in a 400 nm pitch;

**[0080]** FIG. 36a shows simulation results showing the variation of the depth of focus at 8% of the exposure latitude (DOF@8%EL) as a function of the pitch for different types of illumination arrangement, which are shown in FIGS. 36b and 36c, for a pattern corresponding to 75nm holes;

**[0081]** FIG. 36b is an illumination arrangement at the pupil plane of the illuminator that combines information related to isofocal compensation, exposure latitude and dose-to-size and having a 0.4s + 0.90/0.4 quasar illumination;

**[0082]** FIG. 36c is an illumination arrangement at the pupil plane of the illuminator that combines information related to isofocal compensation, exposure latitude and dose-to-size and having a 0.4s + 0.97/0.4 quasar illumination;

**[0083]** FIG. 37 is a flowchart illustrating a method for optimizing the conditions of illumination in accordance with an embodiment of the invention;

**[0084]** FIG. 38a shows the CD variation of a double line pattern for three lenses as a function of wavefront aberration created by lens aberrations;

**[0085]** FIG. 38b is a schematic illustration of the double line structure used to simulate the CD variation due to lens aberrations;

**[0086]** FIG. 39a is a contour map illustrating the contribution of each source point located in the illuminator to the depth of focus calculated at 8% of exposure latitude (DOF@8%EL) and calculated for the double line structure shown in FIG. 38b;

**[0087]** FIG. 39b is a contour map illustrating isofocal

curvature and calculated for the double line structure shown in FIG. 38b;

**[0088]** FIG. 40 represents the CD variation of the double line structure for three lenses and for three types of illumination ( $s=0.25$ ,  $s=0.15$ , and small CQuad +  $s=0.15$ ) as a function of wavefront aberration;

**[0089]** FIG. 41 shows the different illumination arrangements at the pupil plane of the illuminator that are used in the trial of FIG. 40, i.e.  $s=0.25$ ,  $s=0.15$ , and small CQuad +  $s=0.15$ ;

**[0090]** FIG. 42 is a contour map representing CD variation due to aberrations as a function of source point location in accordance with an embodiment of the present invention;

**[0091]** FIG. 43 is a contour map representing the variation of Depth of Focus measured at 8% of Exposure Latitude as a function of source point location for simulations done for the same double line structure depicted in FIG. 38b and for a Chromeless Phase Lithography mask;

**[0092]** FIG. 44 is a contour map representing CD variation due to aberrations as a function of source point location in accordance with an embodiment of the present invention;

**[0093]** FIG. 45 represents the CD variation of the double line structure for three lenses and for three types of illumination (Phase shift mask  $s=0.25$ , CPL mask 0.80/0.55 Quasar 30°, and CPL mask 0.85/0.50 Quasar 45°) as a function of wavefront aberration;

**[0094]** FIG. 46 shows the variation of the Exposure Latitude as a function of the depth of focus for the three types of illumination arrangement shown in FIG. 44;

**[0095]** FIG. 47 is a flowchart illustrating a method for optimizing the conditions of illumination in accordance with an embodiment of the invention;

**[0096]** FIG. 48 is a schematic illustration of a pattern of trenches with mask assist features (anti-scattering bars) disposed on both sides of each trench;

**[0097]** FIGS. 49a and 49b are two contour maps representing the variation of Depth of Focus and Exposure Latitude as a function of source point location for simulations done for the structure depicted in FIG. 48 and for a 6%-attenuated phase shift mask;

**[0098]** FIG. 50 shows the variation of the exposure latitude as a function of depth of focus for various Anti-Scattering bar pitches and for various size and length of CQuad poles; **[00100]** FIGS. 51a and 51b are two contour maps representing the variation of Depth of Focus and Exposure Latitude as a function of source point location for simulations done for the structure depicted in FIG. 48 (without anti-scattering bars) and for a 6%-attenuated phase shift mask; **[00101]** FIG. 52 shows the CD variation of the trench as a function of defocus with the trench exposed with a 35°CQuad and 0.1s illumination that has been selected using isofocal compensation analysis;

**[0099]** FIG. 53 represents the variation of Exposure Latitude as a function of Depth of Focus for the two illu-

mination arrangements selected with the embodiment of the invention represented in FIG. 47;

**[0100]** FIG. 54 represents the variation of Exposure Latitude as a function of Depth of Focus showing the effect of bias on Exposure Latitude; **[00104]** FIG. 55 is a flowchart illustrating a method for optimizing the conditions of illumination with best CDU metric in accordance with an embodiment of the invention;

**[0101]** FIG. 56 schematically illustrates a 50nm double line structure printed on a CPL mask; **[00106]** FIG. 57 is a contour map representing DOF@8%EL variation as a function of source point location in accordance with an embodiment of the present invention;

**[0102]** FIG. 58 is a contour map representing CD variation as a function of source point location in accordance with the embodiment of the present invention shown in FIG. 55; and

**[0103]** FIG. 59 represents CD variation for several illumination arrangements and for various parameters.

## DETAILED DESCRIPTION

**[0104]** Figure 1 schematically depicts a lithographic projection apparatus 1 according to an embodiment of the invention. The apparatus includes a radiation system Ex, IL constructed and arranged to supply a projection beam PB of radiation (e.g. UV or EUV radiation, such as, for example, generated by an excimer laser operating at a wavelength of 248 nm, 193 nm or 157 nm, or by a laser-fired plasma source operating at 13.6 nm). In this embodiment, the radiation system also comprises a radiation source LA. The apparatus also includes a first object (mask) table MT provided with a mask holder constructed and arranged to hold a mask MA (e.g. a reticle), and connected to a first positioning device PM (not shown) to accurately position the mask with respect to a projection system or lens PL; a second object (substrate) table WT provided with a substrate holder constructed and arranged to hold a substrate W (e.g. a resist-coated silicon wafer), and connected to a second positioning device PW to accurately position the substrate with respect to the projection system or lens PL. The projection system or lens PL (e.g. a quartz and/or CaF<sub>2</sub> lens system or a refractive or catadioptric system, a mirror group or an array of field deflectors) is constructed and arranged to image an irradiated portion of the mask MA onto a target portion C (e.g. including one or more dies) of the substrate W. The projection system PL is supported on a reference frame RF.

**[0105]** As here depicted, the apparatus is of a transmissive type (i.e. has a transmissive mask). However, in general, it may also be of a reflective type, (e.g. with a reflective mask). Alternatively, the apparatus may employ another kind of patterning device, such as a programmable mirror array of a type as referred to above.

**[0106]** The source LA (e.g. a UV excimer laser, an undulator or wiggler provided around the path of an electron beam in a storage ring or synchrotron, a laser-pro-



duced plasma source, a discharge source or an electron or ion beam source) produces a beam PB of radiation. The beam PB is fed into an illumination system (illuminator) IL, either directly or after having traversed a conditioner, such as a beam expander Ex, for example. The illuminator IL may comprise a selectably variable beam controller or an adjusting device AM for setting the outer and/or inner radial extent (commonly referred to as  $\sigma$ -outer and  $\sigma$ -inner, respectively) of the intensity distribution in the beam. In addition, it will generally comprise various other components, such as an integrator IN and a condenser CO. In this way, the beam PB impinging on the mask MA has a desired uniformity and intensity distribution in its cross-section.

**[0107]** Still referring to FIG. 1, the projection apparatus also includes a control unit CU which may be programmed to execute the method illustrated, for example, in FIGS. 14, 16, 18, 24, 37, 47, and 55, and may be configured to control the different components of the lithographic apparatus. In an embodiment of the invention, control unit CU may include a processor that is configured to control the adjusting device AM and to modify the cross-sectional intensity distribution in the projection beam exiting the illuminator IL.

**[0108]** It should be noted with regard to Figure 1 that the source LA may be within the housing of the lithographic projection apparatus (as is often the case when the source LA is a mercury lamp, for example), but that it may also be remote from the lithographic projection apparatus, the radiation beam which it produces being led into the apparatus (e.g. with the aid of suitable directing mirrors). The latter scenario is often the case when the source LA is an excimer laser. The present invention encompasses both of these scenarios. In particular, the present invention encompasses embodiments wherein the radiation system Ex, IL is adapted to supply a projection beam of radiation having a wavelength of less than about 250 nm, such as with wavelengths of 248nm, 193nm, 157 nm, 126 nm and 13.6 nm, for example.

**[0109]** The beam PB subsequently intercepts the mask MA, which is held on the mask table MT. Having traversed the mask MA, the beam PB passes through the lens PL, which focuses the beam PB onto a target portion C of the substrate W. With the aid of the second positioning device PW and interferometer IF, the substrate table WT can be moved accurately, e.g. so as to position different target portions C in the path of the beam PB. Similarly, the first positioning device PM (not shown) can be used to accurately position the mask MA with respect to the path of the beam PB, e.g. after mechanical retrieval of the mask MA from a mask library, or during a scan. In general, movement of the object tables MT, WT will be realized with the aid of a long-stroke module (coarse positioning) and a short-stroke module (fine positioning). However, in the case of a wafer stepper (as opposed to a step and scan apparatus) the mask table MT may just be connected to a short stroke actu-

ator, or may be fixed. The mask MA and the substrate W may be aligned using mask alignment marks  $M_1$ ,  $M_2$  and substrate alignment marks  $P_1$ ,  $P_2$ .

**[0110]** The depicted apparatus can be used in the following preferred modes:

1. In step mode, the mask table MT and the substrate table WT are kept essentially stationary, while an entire pattern imparted to the projection beam is projected onto a target portion C in one go (i.e. a single static exposure). The substrate table WT is then shifted in the X and/or Y direction so that a different target portion C can be exposed. In step mode, the maximum size of the exposure field limits the size of the target portion C imaged in a single static exposure.

2. In scan mode, the mask table MT and the substrate table WT are scanned synchronously while a pattern imparted to the projection beam is projected onto a target portion C (i.e. a single dynamic exposure). The velocity and direction of the substrate table WT relative to the mask table MT is determined by the (de)magnification and image reversal characteristics of the projection system PL. In scan mode, the maximum size of the exposure field limits the width (in the non-scanning direction) of the target portion in a single dynamic exposure, whereas the length of the scanning motion determines the height (in the scanning direction) of the target portion.

3. In another mode, the mask table MT is kept essentially stationary holding a programmable patterning structure, and the substrate table WT is moved or scanned while a pattern imparted to the projection beam is projected onto a target portion C. In this mode, generally a pulsed radiation source is employed and the programmable patterning structure is updated as required after each movement of the substrate table WT or in between successive radiation pulses during a scan. This mode of operation can be readily applied to maskless lithography that utilizes a programmable patterning structure, such as a programmable mirror array of a type as referred to above.

**[0111]** Combinations and/or variations on the above described modes of use or entirely different modes of use may also be employed.

**[0112]** Referring to FIG. 9, the illumination system may include light collecting/collimating optics 10; an axicon/zoom module 12; a multipole mode generating element 38; and light integrating and projecting optics 14. The components lie along optical axis 16 and are used to illuminate the mask MA located at a mask plane 20 which then produces an exposure pattern in resist on the wafer W via the projection system or lens PL. The illumination system illustrated in FIG. 9 includes a quartz rod light integrator 26. The optical axis 16 shown in FIG.

9 can be folded to produce a more compact illumination system.

**[0113]** An exemplary embodiment of the multipole mode generating element 38 is shown in FIG. 10a. The element 38 has four triangular blades 41, 42, 43, 44 insertable into the beam path at the pupil plane 18 and which form a Maltese cross 40, which is also referred to herein as a Maltese aperture blade (MAB). Each blade has an apex angle  $\beta$ . FIG. 10b shows the illumination intensity distribution resulting from the combination of an annular illumination mode produced by the axicon/zoom module 12 and the MAB 40. The distribution has four light beams or poles 45. This embodiment enables continuously variable quadrupole illumination modes to be produced. The radial position of each pole 45 can be varied by adjusting the axicon optics 22, the radial width of each pole can be varied by adjusting the zoom lens 24, and the tangential pole width can be changed by inserting another set of blades having a different apex angle  $\beta_1$ , such as Maltese cross 40 shown in FIG. 11. By removing the blades altogether, the illumination system can be used for conventional and/or annular modes, again with continuous variation. **[00119]** Interposing blades of a different apex angle permits the tangential pole width to be changed in discrete steps. According to another embodiment of the invention, the tangential pole width can be continuously varied by each arm of the Maltese cross comprising a stack of  $n$  blades, rotatable with respect to each other about the optical axis of the system where their vertices lie.

**[0114]** According to a further embodiment, just two blades are used as the multipole mode generating element 38 in an optical system which includes a light pipe, such as a rectangular quartz rod 26, as shown in the illumination system of FIG. 9. One of the blades is oriented parallel to the short side of the rectangular cross-section of the light pipe 26 and the other blade parallel to the long side. Due to the multiple reflections in the pipe 26, the resulting illumination mode is a mixture of annular and quadrupole. The two-blade system can produce an illumination mode including a quadruple component with lower energy-loss than the Maltese cross arrangement, as there are fewer blades obstructing the light beam. In one example the blades are triangular and are like two perpendicular arms of a Maltese cross, e.g. blades 41 and 42 shown in FIG. 10a. One or both of the blades in this embodiment can be a composite blade including a stack of smaller rotatable blades as described above.

**[0115]** Typically the blades are positioned along directions corresponding to orthogonal lines on the mask MA, so that the light poles 45 are located in each quadrant with centers  $45^\circ$  from the orthogonal lines. This orientation can produce optimal projection of the lines, particularly for dense structures, such as for DRAM-like structures. The orthogonal lines are generally referred to as horizontal and vertical. As pattern features decrease in size, light poles located in each quadrant with

centers  $90^\circ$  from the orthogonal lines become more preferred. The optimal sigma for quadrupole illumination can be estimated from the formula:  $\sigma = \lambda / (\sqrt{2} NA \cdot pitch)$ , and for dipole and  $45^\circ$  rotated quadrupole from:  $\sigma = \lambda / (2 NA \cdot pitch)$

**[0116]** A further variation on the above embodiments using blades is to make all the blades rotatable about the optical axis 16 of the illumination system so that the position of the poles can be rotated.

**[0117]** Referring to FIG. 12, another exemplary embodiment of the present invention includes the axicon/zoom module with a pyramidal prism 50 as the multipole mode generating element. This also enables conventional, annular and quadrupole illumination to be produced with continuous variations of the modes. FIG. 12 shows the optical components of an axicon/zoom module. The right hand column in FIG. 12 shows the illumination intensity distributions at the pupil plane 18 for various positions of the axicon pair 22a, 22b and zoom lens 24. The axicon pair 22 comprises a pair of elements having conical surfaces, one concave 22a, one convex 22b, to produce circular and annular illumination patterns. The fourth row shows the effect of separating the pyramid-shaped prism 50 from convex element 22b. The side of the convex element 22b facing the pyramid 50 is concave pyramidal for receiving the pyramid 50. The convex element 22b and pyramid 50 comprise a second axicon also known as a pyramidal axicon or pyramidon. The pyramid-shaped prism 50 has a four-sided base, which consequently produces quadrupole mode illumination patterns, such as the four spots illustrated at the bottom in the right hand column in FIG. 12.

**[0118]** The axicon/zoom module of FIG. 12 allows the illumination mode to be varied continuously from conventional to annular or quadrupole. The zoom lens 24 sets the spot size or partial coherence factor, the axicon pair 22 determines the annularity, and the pyramid 50 determines the quadrupolarity. In addition, since light flux is redistributed rather than blocked, there is virtually no light loss, so that a high throughput can be maintained.

**[0119]** The method of the present invention allows for optimization of the illumination conditions of the lithographic apparatus by selecting an appropriate arrangement of the illuminator by computer simulation. In an embodiment of the invention, optimization of the conditions of illumination is achieved with a method including defining a lithographic pattern to be printed on the substrate, selecting a simulation model, selecting a grid of source points in a pupil plane of the illuminator, calculating separate responses for individual source points, each of the responses representing a result of a single or series of simulations using the simulation model, and adjusting an illumination arrangement of the illuminator based on analysis of accumulated results of the separate calculations.

**[0120]** Referring to FIG. 13, an exemplary embodiment of a method for optimizing the conditions of illumi-

nation of a lithographic apparatus will now be explained.

**[0121]** The method begins in step (A1) where a lithographic problem is defined. The lithographic problem represents a particular pattern to be printed onto a substrate. This pattern, which is used to optimize the parameters of the lithographic apparatus and to choose a proper configuration of the illumination system, is preferably representative of an aggressive configuration included in the mask layout. This can be, for example, features with 1:1 to 1:20 line to space duty ratio or a pattern simultaneously grouping dense features and isolated features.

**[0122]** The method then proceeds to step (A2) where the simulation model that calculates the profile of the pattern is selected.

**[0123]** The simulation model may include in an embodiment of the invention an aerial image model. In that case, the distribution of the incident light energy distribution onto the photoresist will be calculated. Calculation of the aerial image may be done either in the scalar or vector form of the Fourier optics. Practically, this simulation may be carried out with the aid of a commercially available simulator such as Prolith™, Solid-C™ or the like. In this embodiment, the characteristics of the different elements of the lithographic apparatus, like the numerical aperture NA or specific patterns, may be entered as input parameters for the simulation.

**[0124]** The image calculated in this embodiment may be evaluated versus some predetermined criteria to judge whether the image has enough contrast to successfully print the desired feature in photoresist on the wafer. The aerial image can be analyzed, through a focus range, to provide estimates of the exposure latitude and DOF and the procedure can be performed iteratively to arrive at the best optical conditions. Practically, the quality of the aerial image may be determined by using a contrast or normalized aerial image log-slope (NILS) metric (normalized to the feature size). This value corresponds to the slope of the image intensity (or aerial image).

**[0125]** In this specific embodiment, key relevant parameters to run aerial image simulations may include the distance from the focal plane of the Gaussian image plane, meaning the distance to the plane where the best plane of focus exists, as determined by the geometrical ray optics, or the center wavelength of the quasi-monochromatic light source. These parameters may also include a measure of degree of spatial partial coherence of the illumination system, the numerical aperture of the lens system illuminating the semiconductor substrates, the aberrations of the optical system and a full description of the spatial transmission function representing the optical mask.

**[0126]** It should be understood that selection of the simulation model, in step (A2), is by no means limited to an aerial image model. Additional models like a Lumped Parameter Model or a Variable Threshold Resist model may also be used in other embodiments of

the invention. In all these embodiments, the model is selected because it has been matched to experimental data. **[00133]** It should also be understood that the use of simulation in step (A2) is not limited to the calculation of the resist profile and that simulations may be carried out to extract additional/complementary responses like process latitude, dense/isolated feature biases, side lobe printing and sensitivity to mask errors.

**[0127]** After defining the resist model and the key relevant parameters, the method then proceeds to step (A3) where a grid of source points, representing a discretization of the source beam, is defined in the pupil plane of the illuminator.

**[0128]** More specifically, illumination files, each representing an individual grid point, are generated and loaded in the simulation software. The light source points contained in the files form a light source point grid that spatially covers the entire cross-section of the illuminator at the pupil plane 18 of the illumination system shown in FIGS. 7-9. The response of the lithographic projection apparatus is calculated for each grid point. The results of the individual responses may be plotted on a contour map, such as shown in FIG. 15. Quantitative analysis of the individual source point results allows comparison of different trial illumination arrangements to determine an optimal illumination arrangement.

**[0129]** The physical location of each light source point relative to the full illuminator aperture is set in the individual source points file and can be varied depending on the degree of accuracy desired. A small spacing between each light source point will provide more detailed information on the source response but may notably increase the calculation time. Conversely, a large spacing between each light source point may provide less accurate information on the source response but will significantly decrease the calculation time. In an embodiment of the invention, the spacing of the grid relative to the full illuminator aperture is approximately 0.1. In other embodiments, the grid spacing is approximately 0.01 to 0.2.

**[0130]** Referring to FIGS. 14(a) and 14(b), a schematic representation of a cross section of the illuminator on which a grid of source points has been overlaid is illustrated. In the present invention, the response of the projection lithographic apparatus is calculated for each grid point. The perimeter of the cross section of the illuminator is represented by circle 1, which delineates the contour of the full illuminator aperture (maximum numerical aperture). The light source grid 2 is also represented in these figures.

**[0131]** In an embodiment of the present invention, in order to estimate how a trial illuminator, i.e. an illuminator considered for use and configurable with the lithographic projection apparatus, will perform, the trial illuminator pattern is overlaid on the grid and the calculated responses are averaged in some way over the included grid points. FIG. 14(a) illustrates an intensity of a projection beam having a circular distribution while FIG. 14

(b) illustrates an intensity of a projection beam having a quasar distribution.

**[0132]** It should be understood that the grid of source points may be defined differently in other embodiments of the invention. For example, as an alternative to illumination files, the grid of source points may be specified parametrically in the simulation software.

**[0133]** Still referring to FIG. 13, the method for optimizing an illumination source of a lithographic projection apparatus proceeds to step (A4) where separate responses are calculated for each grid source point.

**[0134]** More specifically, each of the separate responses will represent a result or series of results of simulations using the simulation models. Potential responses may include, for example, a critical dimension of the pattern studied or an intensity threshold necessary to define the target CD on the substrate. In another embodiment of the present invention, other responses may include the depth of focus (DOF), the exposure latitude (EL), the depth of focus at 8% EL (DOF@8%EL), the dose-to-size  $E_{1,1}$ , dense to isolated feature bias, arbitrary feature size biases, sidelobe printing, film loss, sidewall angle, mask error enhancement factor (MEEF), linear resolution, or absolute resolution.

**[0135]** In order to aid in the optimization of the illumination conditions, the results of the calculations can then be visualized by plotting the contour map of the responses as a function of source point location.

**[0136]** Referring to FIG. 15, an exemplary embodiment of a contour map obtained in accordance with the method of the present invention is provided. FIG. 15 corresponds to the upper right hand of the illuminator at the pupil plane 18. As can be seen in this figure, the source point grid has a 0.1:0.1 spacing relative to the full aperture of the illuminator. For symmetry reasons, only the upper right hand quadrant of the illuminator need be visualized.

**[0137]** The lithographic problem studied is a pattern of 65 nm isolated lines printed with a Chromeless Phase Lithography (CPL) mask. In this embodiment, the wavelength of the projection beam is 193 nm and the numerical aperture of the lithographic projection apparatus is 0.85 NA. Simulations are performed with a 0.2  $\mu\text{m}$  defocus.

**[0138]** In the embodiment illustrated in FIG. 15, the response studied is the Normalized aerial Image Log Slope (NILS), which corresponds to the log of the slope of the intensity image (or aerial image). As can be seen in FIG. 15, the contour map represents the value of NILS obtained on the wafer as a function of the source point position in the illuminator. It is shown that only the source points located at approximately  $45^\circ$  (relative to the line orientation on the mask) and a radius of 0.7 to 0.8 have a significant contribution to greater value of NILS and, therefore, to the depth of focus. Illumination emanating from this region is favorable for printing the isolated lines and illumination from outside this region is not favorable. It is therefore expected that the process window for this

particular lithographic problem will be maximized with a quasar arrangement. The performance of this quasar arrangement can then be determined, for example, by averaging the responses due to the individual source points captured by the illuminator.

**[0139]** Referring back to FIG. 13, the method for optimizing the conditions of illumination of a lithographic projection apparatus proceeds to step (A5) where the illumination conditions of the illuminator are adjusted based on analysis of the responses. In an embodiment of the present invention, this is done, for example, by varying the positions of the axicon pair 22a, 22b and zoom lens 24 shown in FIG. 12. The adjusting of the illuminator may be carried out, in an embodiment of the invention, with the control unit CU.

**[0140]** It should be understood that, in case the performance of a trial illuminator need be estimated, calculation of the responses is performed for the source points captured by the aperture of the illuminator. These source points are schematically represented by the black dots in FIGS. 14(a) and 14(b). In this particular case, the performance of the illuminator may be determined, for example, by averaging the responses due to these captured individual source points.

**[0141]** Referring to FIG. 16, a method for optimizing the conditions of illumination of lithographic projection apparatus according to an embodiment of the invention will now be explained. In this embodiment of the invention, optimization of the conditions of illumination is achieved by computer simulation using full resist calculation with a method including defining a lithographic problem, selecting a resist model, selecting a grid of source points, calculating separate responses for individual source points, each of the responses representing a result of a single or series of simulations using the simulation model, and adjusting an illumination arrangement based on analysis of accumulated results of separate calculations.

**[0142]** As shown previously, it is possible to define the best illumination conditions of the illuminator and to select an appropriate design of aperture by simulating the incident light energy distribution onto the photoresist surface. This quantity is defined as aerial image, in reference to the fact that the intensity of the light is in a plane at the top of the photoresist, prior to entering into the resist. The calculated image can then be evaluated versus some predetermined criteria to judge whether the image has enough contrast to successfully print the desired feature in photoresist on the wafer. The aerial image can be analyzed to provide estimates of the exposure latitude and depth of focus and the procedure can be performed iteratively to arrive at the best optical conditions.

**[0143]** As also shown previously, the quality of the aerial image may be determined by using a normalized aerial image log-slope (NILS) metric (normalized to the feature size). This value corresponds to the log of the slope of the intensity image (or aerial image). In this ap-

proach, the best illumination setting or shape may be determined using an analysis of aerial image metrics (e. g. NILS or contrast) at some fixed defocus value. The best lithographic process latitude may be found when the aerial image quality is high.

**[0144]** In order to simulate the aerial image of the mask pattern, the parameters of the different elements of the photolithographic apparatus are required as input parameters in the simulation programs. These parameters typically include geometric parameters of the projection system and the illuminator, and optical parameters such as the numerical aperture NA of the projection system and the partial coherence factor  $s$  of the photolithographic apparatus. Although many parameters may be required to adequately determine the profile of the aerial image at the top of the photoresist, the theory used to calculate the image is well developed and is based on the Fourier optics either in its scalar or vector form.

**[0145]** A "pure aerial image" approach may not, however, accurately predict the final image printed onto the substrate. This is due to the fact that this approach disregards the effects of the image receiver, i.e., the photoresist. The interaction of the electromagnetic field with the photoresist, also referred to as the vector effects, and the physical and chemical characteristics of the resist, for example, are not accounted for in the calculation. Basically, in order to match the predictions of the aerial image calculations that use a fixed intensity threshold to determine the printed CD, the photoresist would have to exhibit infinite dissolution contrast with zero diffusion of the photo-generated species. Unfortunately, such photoresist processes do not exist. An accurate photoresist simulation model includes the effects associated with diffusion of the active species (which "smear" the projected optical image) and the finite dissolution contrast of the real photoresist, and gives predictions which match experiment. The reasons for differences between aerial image predictions and real resist processes, and some of their characteristics, is discussed in "The Resist Vector: Connecting the Aerial Image to Reality," Proc. SPIE, Vol. 4690, p. 366 (2002), the entire contents of which are incorporated herein by reference.

**[0146]** Therefore, in order to accurately predict the process window of a lithographic process or to select the best illumination arrangement, a full resist calculation may be desirable. Ideally, this calculation should take into account the steps of photoresist exposure, photoresist baking (PEB) and photoresist developing. Photoresist exposure occurs when the projection beam changes the chemical nature of the resist by activating the molecules of the resist material. Depending on the nature of the resist, i.e. conventional i-line resist or chemically amplified resist, different models can be used to simulate the interaction between the projection beam and the resist material and to calculate the change of the absorption coefficient of the resist material.

**[0147]** The method begins in (B1) where a lithographic problem is defined. The lithographic problem may represent a particular geometry of a pattern to be printed onto a wafer.

5 **[0148]** The method then proceeds to step (B2) where a resist process to be used to print the pattern is defined, modeled and loaded in the simulation software, such as Prolith™, Solid-C™ or the like. Preferably, the resist model should take into account, in the calculation of the  
10 resist's critical dimension (or size) and its variation with variables such as dose and focus, the photoresist exposure, the photoresist baking and the photoresist developing. Other responses, such as dense/isolated feature biases, side lobe printing and mask error enhancement factors, may be defined and modeled by the simulation software.

15 **[0149]** Likewise, the resist model chosen in (B2) may take into account, in an embodiment of the invention, the scattering of the electromagnetic field caused by the inhomogeneity of the resist, a nonplanar topography and the vector effects. The vector effects refer to the fact that the electromagnetic wave propagates obliquely when high numerical apertures are used. Although these vector effects can be accounted for when calculating the aerial image, a calculation of the vector effects  
20 in air greatly overestimates the contrast loss obtained on the wafer. This is due to the fact that the incident rays tend to be straightened when they propagate in the resist because of the resist's refractive index. Therefore, a resist model with a rigorous electromagnetic calculation may be preferable to accurately determine the resist response.

25 **[0150]** The choice of the resist model in (B2) may also take into account, in an embodiment of the invention, the photoresist baking. A post exposure bake may be used prior to developing the resist pattern. Besides removing the solvent, this allows the regions of high concentration in the photoactive compound to be diffused into the regions of low concentration, thereby smoothing out standing wave patterns. A classical diffusion process may be used to model this baking process. Alternatively, other models accounting for the nonlinear diffusion effects may also be used in another embodiment of the invention.

30 **[0151]** The method then proceeds to step (B3) where illumination files, each representing an individual grid point, are generated and loaded in the simulation software. The light source points contained in the files form a light source point grid that spatially covers the entire cross-section of the illuminator at the pupil plane 18 of the illumination system shown in FIGS. 7 and 9.

35 **[0152]** The method then proceeds to step (B4) where separate responses are calculated for individual source points using a full resist calculation. In the embodiment of the invention represented in FIG. 16, each of the separate responses may represent a result or series of a  
40 single or series of simulations using the simulation model. The responses studied may include, for example, the  
45  
50  
55

Depth of Focus (DOF), the Exposure Latitude (EL), Depth of Focus at 8% of Exposure Latitude (DOF@8%EL), the dose-to-size  $E_{1:1}$ , dense to isolated feature bias, arbitrary feature biases, sidelobe printing, film loss, sidewall angle, Mask Error Enhancement Factor (MEEF), linear resolution, or absolute resolution. These responses can also be visualized by plotting the contour map of the results as a function of the source location.

**[0153]** Referring to FIG. 17, an example of a contour map obtained with this method is shown. This figure represents the upper right hand quadrant of the illuminator at the pupil plane 18. The response visualized is the depth of focus in microns. As shown in FIG. 17, the source point grid has a 0.1:0.1 spacing relative to the full aperture of the illuminator. The lithographic problem studied was a pattern of 65 nm isolated lines printed with a chromeless phase lithography (CPL) mask, a 0.85 NA and 193 nm radiation. For symmetry reasons, only the upper right hand quadrant of the illuminator need be visualized. This contour map represents the depth of focus obtained on the wafer as a function of the source point position in the illuminator. It is shown that only the source points located at approximately  $45^\circ$  (relative to the line orientation on the mask) and a radius of approximately 0.5 to 0.8 have a significant contribution to the depth of focus. Illumination emanating from this region is favorable for printing the isolated lines and illumination from outside this region is not favorable. It is also shown that a maximum depth of focus of about 0.5 to 0.6  $\mu\text{m}$  is expected with the best quasar arrangement. Similar contour maps may be obtained for the exposure latitude and the dose-to-size  $E_{1:1}$ .

**[0154]** After calculating the separate responses for the individual source points, the method then proceeds to step (B5) where the illumination arrangement is adjusted based on an analysis of the accumulated results of the separate calculations. The performance of the best arrangement can be determined, for example, by averaging the responses captured by the actual illuminator being considered.

**[0155]** Referring to FIG. 18, an exemplary embodiment of a method for obtaining a refined process window of a lithographic problem will now be explained. In this embodiment, the method begins in (B1) and proceeds to step (B5) in the same way as in the embodiment shown in FIG. 16. The method then proceeds to (B6) where a first order dose correction is applied to the average value of the responses. The first order correction may be done by a simple average, i.e. by counting the points included in the circle 1. The first order correction may also be done by interpolation to make extra grid points. In a preferred embodiment, the first order correction may still also be done by a weighting of the points based on their calculated sizing doses, i.e. by dose weighted averaging. The lithographic projection apparatus may use only one dose. The calculations, however, may determine a best dose for each individual grid

point. Even if a point included in the circle 1 provides a good individual response, if its dose is not close to the one provided by the lithographic projection apparatus it does not contribute favorably to the response obtained with the real illuminator. Individual points may thus be weighted on the basis of the difference between their individual dose and the dose of the lithographic projection apparatus. Those points having smaller differences are weighted higher than points having larger differences. The first order correction may also be done by a combination of interpolation and dose weighted averaging.

**[0156]** In an embodiment of the invention, the refined values are obtained by increasing the number of points contained within the aperture. This is done by diminishing the spacing between the source points. In another embodiment of the invention, a linearly interpolated grid may be used in combination with a smaller grid spacing. The interpolated grid provides a smoother averaging process by providing a "higher resolution" grid that reduces numerical errors caused by slight movement of the trial illuminator changing the specific source points captured

**[0157]** While a first order correction has been applied to the average response calculated with the method illustrated in FIG. 16, i.e. using a full resist calculation, it should be understood that a similar approach may be pursued in the method illustrated in FIGS. 13, 24, 37, 47 and 55.

**[0158]** Referring to FIG. 19, simulations obtained with a commercial simulation software using a full resist calculation are compared to calculations obtained with the methods described in FIGS. 16 and 18. Calculation is done for several embodiments set forth above. That is, the depth of focus is calculated either using the DOF value of individual source points (method of FIG. 16, "average from illum. map"), a first order dose correction ("dose weighted avg. from illum. map"), an interpolated grid ("interpolated and avg. illum. map") or a combination of an interpolated grid and a first order dose correction ("interpolate and dose weight").

**[0159]** The bars in the diagram represent the value of the depth of focus (with a simultaneous 8% exposure latitude constraint) obtained with several arrangements of illuminator. FIG. 20 represents the different arrangements used in this trial. The cross section of the projection beam at the pupil plane 18 is shown for each illuminator. These different illumination arrangements can be obtained, for example, by appropriate adjustment of the multipole generating element 38 in FIG. 9.

**[0160]** The lithographic problem studied in this trial corresponds to a pattern of 80nm holes with a 200nm pitch. Simulations of the hole size in resist are made with a commercial software (Prolith™ using full illuminator calculations and the results are compared to the averaged results of the grid simulations. The comparison of the different averaging approaches discussed above to the calculations obtained with the trial illuminator allow a quantitative analysis of the accuracy of the averaging

methods and selection of the best illuminator. As averaging calculated grid points requires less time than running simulations of various trial illuminators, the present invention can more quickly determine the best illuminator for a particular lithographic problem.

**[0161]** FIG. 19 indicates that both the lengthy Prolith™ calculation and the calculations obtained with the methods described in FIGS. 16 and 18 concur in the choice of dose weighted interpolation for the best illuminator.

**[0162]** Referring to FIG. 21, predictions of the DOF value (simultaneously constrained to at least 8% exposure latitude) based on the weighted and interpolated source measurements are compared to the prediction obtained with Prolith™. The comparison is made for several trial illuminators (shown in FIG. 18). Data indicate that predictions obtained with the method of the present invention satisfactorily match the prediction obtained with Prolith™. These results point out that the method of the present invention favorably match the predictions obtained with the actual illuminator and used for source selection, optimization, and design.

**[0163]** Referring to FIG. 22, predictions obtained with a full resist calculation (according to the method described in FIG. 16) are compared to the predictions obtained with a scalar aerial image metric at different defocus values (NILSF2 and NILSF3). The defocus used for maximizing the process window and determining the best illumination conditions are 0.2 μm (NILSF2) and 0.3 μm (NILSF3). The lithographic problem studied is the same as above and corresponds to a pattern of 80 nm holes with a 200 nm pitch and the trial illuminators used are identical to those described in FIG. 20. Results indicate that the aerial image metrics predict the best illuminator to a lesser extent.

**[0164]** Referring to FIG. 23, a similar trial as in FIG. 22 is carried out for a different lithographic problem. The lithographic problem studied in this trial corresponds to a pattern of 80 nm holes with a 300 nm pitch. Both NILS and aerial image intensity at the mask edge MEF2 (i.e. with a 0.2 μm defocus) miss the best illuminator predicted by the full resist simulations.

**[0165]** Results in the trials described in FIGS. 22 and 23 indicate that NILS measurements, which may be used to maximize the process window, less precisely predict the best illumination conditions and further do not quantitatively predict the process window. The fall off in accuracy is expected to be worse as NA increases (stronger vector effects) and for certain processes which have moderate contrast and print far away from the aerial image limit

**[0166]** Referring now to FIG. 24, a method for optimizing the conditions of illumination of lithographic projection apparatuses according to an embodiment of the invention will now be explained. In this embodiment, selection of the illuminator arrangement is done so that the lithographic process obtained is substantially isofocal over a predetermined range of defocus. In an embodi-

ment of the invention, isofocal compensation is achieved with a method including: defining a lithographic pattern to be printed on a substrate; selecting a simulation model; selecting a grid of source points in a pupil plane of the illuminator; calculating separate responses for individual source points, each of the responses representing a result of a single or series of simulations using the simulation model; calculating a metric representing variation of the separate responses for individual source points with defocus; and adjusting an illumination arrangement based on analysis of the metric.

**[0167]** In the method illustrated in FIG. 24, optimization of the illumination conditions is based on the fact that for many lithographic problems two opposite failure mechanisms in defocus exist. This principle is illustrated in FIG. 25, which represents a focus exposure matrix at fixed CD on the mask. This matrix, also called a Bossung plot, captures important lithographic information, and more specifically the variation of the CD as a function of focus for different exposure energies.

**[0168]** In FIG. 25, the lithographic useful dose and focus are defined by their ability to equally print structures of the desired size. In this graph, the lithographic process will be deemed robust if a large variation in focus and dose minimally impacts the target CD. Practically; this requires to keep the printed CD within a range of acceptable CDs. This range is schematically illustrated in FIG. 25 by the CDs comprised between dotted lines (1) and (2). Ideally, this robust process will be portrayed by the "isofocal" segment AB in the Bossung plot.

**[0169]** As can be seen in this graph, errors in focus and dose can lead to two opposite effects, which can trigger a failure mechanism for the lithographic process. The first effect is characterized by a CD increase outside the range of acceptable CDs while the second effect is characterized by a CD decrease outside this range.

**[0170]** Therefore, in order to render the lithographic process substantially isofocal (i.e. insensitive to focus errors) optimization of the lithographic process is performed in an embodiment of the invention by compensating one effect with another. More particularly, this is achieved, in an embodiment of the invention, by balancing the regions in the illuminator producing failure due to high CDs with defocus with the regions producing failure due to small CDs, with defocus. By doing so, CD variations within the process window are drastically decreased, a substantially isofocal process over the predetermined range of focus may be obtained, and the focus range (DOF) over which the CDs remain acceptable is augmented.

**[0171]** More specifically, the method for optimizing the illumination conditions of a lithographic apparatus provides in an embodiment of the invention a new metric that accounts for the variations of the target CD with defocus. The metric in this embodiment calculates, for each source point situated in the illuminator, the CD at a given defocus and compares this result with the CD obtained at the best focus. This computation is subse-

quently reiterated for all the source points located in the illuminator. Adjustment of the illumination conditions is then performed on the basis of the comparison of the results obtained for each source point. More specifically, adjustment of the illumination conditions is performed by selecting an illumination arrangement combining areas of the illuminator producing, in the defocused condition, high CDs on the substrate with areas of the illuminator producing small CDs on the substrate.

**[0172]** The method of the present invention allows for calculation of the CDs of the pattern and more generally of the response for each source point by computer simulations.

**[0173]** In an embodiment of the invention an aerial image model may be used to calculate the separate responses. In this embodiment, the incident light energy distribution onto the photoresist surface is simulated. Simulation of the aerial image may be done with the aid of commercially available simulators such as Prolith™ or the like. As mentioned previously, the models used in such a case are well known and are based on the Fourier optics either in its scalar or vector form. In this embodiment, the characteristics of the different elements of the photographic apparatus, like the numerical aperture NA or specific patterns, may be entered as input parameters for the simulation.

**[0174]** Also, in this embodiment, the calculated image may be evaluated versus some predetermined criteria to judge whether the image has enough contrast to successfully print the desired feature in photoresist on the wafer. The aerial image can be analyzed, through a focus range, to provide estimates of the exposure latitude and DOF and the procedure can be performed iteratively to arrive at the best optical conditions. Practically, the quality of the aerial image may be determined by using a contrast or normalized aerial image log-slope (NILS) metric (normalized to the feature size). This value corresponds to the slope of the image intensity (or aerial image).

**[0175]** **[00182]** In this embodiment, the response studied for each source point may be the variation with defocus of the intensity threshold of the aerial image giving the target CD. Alternatively, in another embodiment of the invention, the response studied may be the variation of the CD with defocus at fixed intensity threshold (i.e., at the intensity threshold of the aerial image giving the target CD).

**[0176]** In another embodiment of the present invention, simulation of the responses for each source point can be performed using a full resist calculation. In this approach, the effect of the image receiver, i.e. the photoresist, and more specifically the effects due to the interaction of the electromagnetic field with the photoresist will be accounted for in the computation. The full resist process simulation may also take into account the steps of photoresist baking and photoresist developing, thereby considering the effects due to non-zero diffusion of active physical species or finite dissolution contrast.

**[0177]** In this model, input parameters may comprise dissolution parameters ( $R_{\min}$ ,  $R_{\max}$ ; Mack4n and  $M_{th}$ ; notch model  $n$ ,  $n_{\text{notch}}$ , and  $M_{th}$ ), bake parameters (diffusion length, quencher concentration (Q), amplification rate constant [ $K_{\text{amp}}$ ]), and optical parameters (Dill B).

**[0178]** Referring back to FIG. 24, an exemplary embodiment of a method for optimizing the illumination conditions of a lithographic apparatus using isofocal compensation will now be explained.

**[0179]** The method begins in step (C1) where a lithographic problem is defined. The lithographic problem represents a particular pattern to be printed onto a substrate. This pattern, which is used to optimize the parameters of the lithographic apparatus and to choose a proper configuration of the illumination system, is preferably representative of an aggressive configuration included in the mask layout.

**[0180]** The method then proceeds to step (C2) where the simulation model that calculates the profile of the pattern is selected.

**[0181]** The simulation model may include in an embodiment of the invention an aerial image model. In that case, the distribution of the incident light energy distribution onto the photoresist will be calculated. Calculation of the aerial image may be done either in the scalar or vector form of the Fourier optics. Practically, this simulation may be carried out with the aid of a commercially available simulator such as Prolith™, Solid-C™ or the like.

**[0182]** As mentioned previously, key relevant parameters to run aerial image simulations may comprise the distance from the focal plane of the Gaussian image plane, meaning the distance to the plane where the best plane of focus exists, as determined by the geometrical ray optics, or the center wavelength of the quasi-monochromatic light source. These parameters may also include a measure of degree of spatial partial coherence of the illumination system, the numerical aperture of the lens system illuminating the semiconductor substrates, the aberrations of the optical system and a full description of the spatial transmission function representing the optical mask.

**[0183]** Alternatively, the simulation model may be based in another embodiment of the invention on a full resist calculation. In such a case, the simulation may take into account the scattering of the electromagnetic field caused by the non-homogeneity of the photoresist, a non-planar topography or the vector effects. The resist model should also preferably take into account the photoresist exposure, the photoresist baking and the photoresist developing.

**[0184]** Naturally, in the event that a full resist calculation is used, essential parameters to run the simulation will be defined and loaded in the simulator. These parameters may include, besides the set of parameters used in the aerial image simulation, the dissolution and the bake parameters. **[00192]** It should be understood that selection of the simulation model, in step (C2), is by



no means limited to an aerial image model or a full resist calculation model. Additional models like a Lumped Parameter Model or a Variable Threshold Resist model may also be used in other embodiments of the invention. In all these embodiments, the model is selected because it has been matched to experimental data.

**[0185]** It should also be understood that the use of simulation in step (C2) is not limited to the calculation of the resist profile and that simulations may be carried out to extract additional/complementary responses like process latitude, dense/isolated feature biases, side lobe printing and sensitivity to mask errors.

**[0186]** The method then proceeds to step (C3) where a grid of source points, representing a discretization of the source beam, is defined in the pupil plane of the illuminator.

**[0187]** More specifically, illumination files, each representing an individual grid point, are generated and loaded in the simulation software. The light source points contained in the files form a light source point grid that spatially covers the entire cross-section of the illuminator at the pupil plane 18 of the illumination system shown in FIGS. 7-9. As mentioned in the foregoing discussion, it should be understood that the grid of source points may be defined differently in other embodiments of the invention. For example, as an alternative to illumination files, the grid of source points may be specified parametrically in the simulation software.

**[0188]** Still referring to FIG. 24, the method for optimizing an illumination source using isofocal compensation proceeds to step (C4) where separate responses are calculated for each grid source point.

**[0189]** More specifically, each of the separate responses will represent a result or series of results of simulations using the simulation models. Potential responses may include, for example, a critical dimension of the pattern studied or an intensity threshold necessary to define the target CD on the substrate.

**[0190]** After calculation of the separate responses for individual source points, the method then proceeds to step C5 to estimate the variations of the separate responses for individual source points with defocus.

**[0191]** In an embodiment of the invention, this is achieved by a metric that calculates another set of responses for the individual source points at a given defocus. The metric will then compare the responses obtained at defocus with the responses calculated at best focus, and generate a metric-response for each source point. In the event that the response is a critical dimension, the CD obtained at defocus will be subtracted from the CD calculated without defocus, or vice versa. Alternatively, if the response studied is the intensity threshold, the intensity threshold obtained at defocus will be subtracted from the intensity threshold determined without defocus. In doing so, the variation of the CD or the intensity threshold with defocus may be established. The value of the defocus may be set within or outside the range of depth of focus initially sought. In an embod-

ment of the invention, the value of the defocus may be within a range from 0.02 to 0.4 $\mu$ m.

**[0192]** In order to aid in the optimization of the illumination conditions, the results of the metric can then be visualized by plotting the contour map of the metric-responses as a function of source location.

**[0193]** Referring to FIGS. 26a and 26b, exemplary embodiments of a contour map obtained in accordance with the method of the present invention are provided. FIGS. 26a-b correspond to the upper right hand of the illuminator at the pupil plane 18. As can be seen in these figures, the source point grid has a 0.1:0.1 spacing relative to the full aperture of the illuminator. For symmetry reasons, only the upper right hand quadrant of the illuminator need be visualized. **[00202]** The lithographic problem studied was a pattern of 90 nm holes in a 360 nm pitch (See FIG. 26c). FIG. 26a represents a contour map of the metric-responses obtained with resist calculation. In that case, the metric calculates and compares the critical dimension of the pattern obtained at best focus and defocus. FIG. 26b is an example of a contour map, which is obtained with aerial image simulation. In this example, the metric compares the intensity threshold at best focus and the intensity threshold for a 0.2 $\mu$ m defocus. In this embodiment, it should be noted that a variation of the threshold intensity in an aerial image simulation is equivalent to a CD variation.

**[0194]** These contour maps indicate the regions of the illuminator that generate an increase or a decrease in the hole CD with defocus, and the magnitude of the size offset. Each area of the illuminator gives a CD change with defocus compared to the CD obtained at best focus. In FIG. 26a, the CD variation is calculated in nanometers and in FIG. 26b, the intensity threshold variation where an intensity value of 1.0 represents the open frame value.

**[0195]** Referring now in more detail to FIG. 26a, the regions of the illuminator producing an augmentation of the CD are concentrated in the extreme bottom left of the quadrant. They reflect a CD augmentation of around 25-50nm. This corresponds in a Bossung plot to a "smiling" curve. By contrast, the areas of the illuminator creating a diminution of the CD are located in the center of the map. In that case, the curves in the Bossung plot will "frown" severely and holes will be closed (CD=0) when out of focus.

**[0196]** Similar information may be obtained in the contour map illustrated in FIG. 26b. As can be seen in this graph, the areas of the illuminator where an augmentation of the CDs is the most significant are located in the bottom left portion of the quadrant. Conversely, the center of the quadrant will be representative of the region in the illuminator producing a diminution of the intensity threshold and the CD.

**[0197]** These contour maps may be reduced in one embodiment of the invention to contour maps representing opposite isofocal behaviors, as shown in FIGS. 27a-b.

**[0198]** In these maps only two regions are depicted. The first one corresponds to the region of the illuminator creating an augmentation of the CD, which is represented respectively by the positive sign region in the full resist model and the negative sign region in the aerial image calculation. Conversely, the second area corresponds to the region of the illuminator creating a diminution of the CD and is represented by an opposite sign region.

**[0199]** Referring back to FIG. 24, the method for optimizing the illumination conditions using isofocal compensation proceeds to step (C6) where the illumination conditions of the illuminator are adjusted based on the analysis of the metric.

**[0200]** In an embodiment of the invention, the optimization of the illumination conditions is earned out by selecting a type of illumination that combines regions producing an augmentation of the value of the responses (CD or intensity threshold) with regions producing a diminution of the value of the responses. Practically, this means that, in FIG. 27a-b, positive sign regions are balanced with negative sign regions, or vice versa.

**[0201]** The balancing of the regions may be done in an embodiment of the invention by selecting some source points in the positive regions and in the negative regions, as shown in FIG. 28. Practically, selection of these source points should take into account the aptitude of these source points to print the target CD. In other words, in this embodiment of the invention, a weight may be attributed to each source point. In the case of an aerial image simulation, the weight of a source point will depend on the intensity of the aerial image obtained from this source point. In the case of a full resist calculation, the weight of a source point will be inversely proportional to the dose required to print the target CD (i.e. CD to size) at best focus. As a result, if the required dose is low for this source point, then that point may potentially counterbalance a relatively larger area in the region of opposite sign. Naturally, if the source points have substantially the same weight, the balancing of the regions is done by selecting an equal number of source points in the positive regions and in the negative region. In FIG. 28, this results in selecting a 0.25-s illumination arrangement (i.e. the arrangement that defines an aperture corresponding to the arc shown in FIG. 28). In so doing, the lithographic process is rendered substantially isofocal over the range of defocus studied.

**[0202]** Results in terms of CD variation with a 0.25-s illumination arrangement are shown in FIG. 29. This graph corresponds to a matrix exposure that illustrates the variation of the critical dimension of the 90 nm holes as a function of the focus for several exposures. As can be seen in this graph, there is almost no variation of the CD over the range of focus studied, regardless of the exposure energies.

**[0203]** It should be understood that supplementary responses may also be taken into account in selecting the best illumination conditions. These responses may in-

clude in an embodiment of the invention the Exposure Latitude EL, the dose-to-size E1:1, the depth of focus at 8% EL (DOF@8%EL), dense-iso bias, or MEEF.

**[0204]** These responses may carry additional information that may be pertinent in the determination of the optimal arrangement of the illuminator. Calculation of the responses may be based on the same principles set forth in the present invention. That is, separate responses for individual source points may be calculated, each of the responses representing a result of a single or series of simulations using the simulation model. Naturally, simulations for each of these responses may be run with an aerial image model or a full resist calculation.

**[0205]** FIGS. 30a-b illustrate contour maps obtained with a full resist calculation. In the first graph, the response studied is the maximum exposure latitude. In the second graph, the dose-to-size E1:1 response is analyzed. As can be seen in these graphs, different areas of the illuminators give different values for these responses and will contribute to an optimization of the illumination conditions. For example, the areas of the illuminator that will enhance the exposure latitude are located in the upper right portion of the quadrant. Similarly, useful areas that lead to a favorably low E1:1 are also situated in the upper right portion in the contour map.

**[0206]** It is therefore expected that the best illumination conditions to print the 90 nm holes in a 360 nm pitch will be provided by an illumination arrangement as shown in FIG. 31. This figure indicates the profile of the projection beam in the pupil plane of the illuminator. This arrangement combines a on-axis illumination and off axis quasar illumination. Simulated results in terms of depth of focus and exposure latitude obtained with the illumination arrangement shown in FIG. 31 are provided respectively in FIGS. 32 and 33. As can be seen in these graphs, there is almost no variation of the CD and the exposure latitude through defocus.

**[0207]** FIG. 34 compares variation of the exposure latitude with defocus for a process optimized with (1) standard calculation (in that case a full resist calculation) which maximizes depth of focus at a fixed dose latitude, (2) isofocal compensation based on a simple illuminator design or (3) isofocal compensation using a complex illuminator and targeting maximum dose latitude. This figure shows that isofocal compensation substantially increases the DOF. This figure also shows that the exposure latitude can be greatly increased while maintaining high DOF by combining appropriate parts of the illuminator. Note that the same enhancement could be obtained by analyzing aerial image calculations including information on the NILS at best focus. Because NILS is proportional to exposure latitude, such an analysis would also lead to a combination of on-axis and off axis illumination to give isofocal performance with high dose latitude.

**[0208]** A similar approach was used to optimize the illumination conditions for another lithographic problem. Examination of a case where a wide range of contact

hole pitches must be printed simultaneously using an attenuated phase shift mask leads to a conclusion that a combination of quasar illumination (for dense pitches) and small sigma (for isolated pitches) gives best results. More careful analysis of an "isolated pitch", in this case, the lithographic pattern studied corresponds to 75 nm holes in a 400 nm pitch illuminated with a 193 nm source under a 1.1 numerical aperture, provides new information. FIGS. 35a-d show simulation results obtained, respectively, for the exposure latitude (max-EL), the depth of focus (max DOF), the depth of focus at 8% of the exposure latitude (DOF@8%EL) and the isofocal curvature.

**[0209]** The first three responses obtained with full resist calculation indicate that a small sigma illumination would be best for this isolated pitch, as expected. By contrast, isofocal curvature simulation shows that addition of a small quasar arrangement at the very edge of the pupil, would add isofocal compensation to the lithographic performance. It was therefore concluded that the best illumination arrangement would extend the quasar plus small sigma illumination beyond that normally needed to print the dense pitches.

**[0210]** Simulated results in terms of depth of focus measured at 8% of the exposure latitude (DOF@8%EL) are illustrated in FIG. 36a for the types of illumination arrangement predicted with the method of the present invention. This graph shows the variation of DOF@8%EL as a function of the pitch. For reference, FIGS. 36b and 36c illustrate the source shape with two types of arrangement (in terms of NA and quasar illumination) at the pupil plane of the illuminator.

**[0211]** As can be seen in this graph, the DOF@8%EL remains stable, regardless of the pitch. More importantly, this figure indicates that a small variation of the quasar illumination may lead to a significant increase in the depth of focus. In that case, isofocal compensation showed that a 0.97 quasar illumination was better than a 0.90 quasar illumination, particularly for the isolated pitches. Simulation of the variation of the DOF@8%EL as a function of pitch clearly corroborates this result. This notable increase in DOF, which could not be predicted with standard calculations, clearly indicates that isofocal compensation calculations are extremely useful to optimize the lithographic process.

**[0212]** Referring now to FIG. 37, a method for optimizing the conditions of illumination of a lithographic projection apparatus according to an embodiment of the invention will now be explained. In this embodiment of the invention, the effects of lens aberrations are accounted for in optimizing the conditions of illumination. More particularly, the aberration sensitivity to the illumination conditions is calculated as a function of the source point location, and that information is then used to select the best condition of illumination.

**[0213]** In this embodiment of the invention, the optimization of the source for minimizing aberration sensitivity is achieved with a method including: defining a lith-

ographic pattern to be printed on the substrate; selecting a simulation model; selecting a grid of source points in a pupil plane of the illuminator; defining at least one aberration set for the projection system; calculating separate responses for individual source points and for the at least one aberration set, each of the responses representing a result of a single or series of simulations using the simulation model; and adjusting an illumination arrangement of the illuminator based on analysis of accumulated results of the separate calculations.

**[0214]** A major source of CD variations in lithography is caused by lens aberrations. Therefore, regardless of the light source utilized in the fabrication process, the fabrication of devices having critical dimensions of 150 nm or less requires that the near-diffraction-limited lens utilized in the fabrication process be substantially aberration free. As is known in the industry, aberrations can be caused by various sources, such as a defective lens or an aging laser which emits a beam having a frequency shifted from the desired value. Accordingly, it is desirable to verify lens performance (i.e., qualify the lens) prior to installation, and then to subsequently monitor the lens performance during use (e.g., in an IC fabrication process).

**[0215]** During the lens manufacturing process, the lens performance can be fully tested interferometrically. Typically, the lens is first qualified at the factory and then again during the initial installation in the field. One common practice utilized for lens qualification is to print wafers and then measure the dimensions of the minimum feature width, or the critical dimension (CD). During this qualification process, both "vertical" and "horizontal" features are measured (i.e., features extending in two orthogonal directions on the substrate plane). In some instances, the CD for 45-degree features is also measured. In order to verify lens performance, a sufficient number of CD measurements are required across the entire exposure field. The results of the CD measurements are then analyzed to determine whether or not the lens performance is acceptable.

**[0216]** An example of CD variations generated by lens aberration is shown in FIG. 38a. This figure illustrates simulated CD variations (in arbitrary units) of a double line structure and more particularly, the difference in width between the left and right line (of this double line structure) as a function of lens aberration. This structure was selected in this trial for its good sensitivity to lens aberrations. For reference, the double line structure is depicted in FIG. 38b. As can be seen in this figure, this structure includes two lines/ having a width of 50nm. The pitch of the lines is 230nm and the pair repeats at a larger pitch. A transparent 180° phase shift window PSW is also placed between the lines (See FIG. 38b).

**[0217]** In this trial, simulations of CD variations are performed for three similar lenses with a lithographic projection apparatus having a numerical aperture of 0.75NA, an illumination condition of 0.25s and a radiation of 157nm. For each lens, the RMS (Root Mean

Square) values of an aberration set, which correspond to aberrations on several points of the lens field, are known and have been extracted using conventional measurement techniques (by interferometry, for example). Each RMS value, each corresponding to an aberration measured at a specific point in the field, represents the quadratic sum of the (Zernike) coefficients of the Zernike polynomial, which is used to model the wavefront aberration at this specific point in the lens. More specifically, this RMS value represents the departure of the wavefront of the propagating wave from sphericity. It should be noted that, in this trial and in the embodiment of the method illustrated in FIG. 37, the aberrations are considered together as an overall wavefront error rather than as specific aberrations. In other words, each RMS aberration value may represent different types of aberrations (like the Seidel aberrations, which include coma, astigmatism, field curvature, distortion or spherical aberrations).

**[0218]** As can be seen in these graphs, the double line structure is very aberration sensitive. A small aberration of 10 milliwaves, for example, may generate a left/right vertical line CD variation in the field of about 10%.

**[0219]** FIGS. 39a and 39b show the contour maps of the  $\text{DOF}@8\%EL$  and isofocal curvature response simulated for the double line structure. Simulations were done using a full resist calculation and for the same conditions of illumination as before (075NA and 157nm). As can be seen in FIG. 39a, the contour map of  $\text{DOF}@8\%EL$  shows that a small portion of the center of the illuminator favorably contributes to a high depth of focus. By contrast, the isofocal curvature map indicates that illumination from the edge of the illuminator may favorably increase the process window. It is therefore expected that a combination of a small sigma and wide quasar illumination will greatly improve the lithographic process.

**[0220]** In order to validate the choice of the illumination arrangement (i.e. a small sigma and wide quasar illumination, see FIG. 41), a trial similar to the one illustrated in FIG. 38a is conducted. Results of this trial are shown in FIG. 40. As can be seen in this figure, it is indicated that the alternate settings have higher sensitivity aberrations and that an illumination with  $s=0.25$  remains favorable to limit CD variation of the double line structure. These results clearly show that it is desirable to take into account the lens aberrations to optimize the conditions of illumination.

**[0221]** Referring back to FIG. 37, the method for optimizing the conditions of illumination by reducing aberration sensitivity begins in step (D1) and proceeds to step (D3) in the same way as in the embodiments of the present invention shown, for example, in FIGS. 13 and 24. The method then proceeds to step D4 where at least one aberration set for the projection system is defined. As explained before, this aberration set contains aberrations corresponding to different locations in the field. In an embodiment of the present invention, the aberration set consists of 13 individual points. However, it should be understood that this aberration set may include more or fewer points depending on the degree of accuracy sought. It should be noted, in this respect, that a lens is conventionally specified by the manufacturer on 13 points. In addition, it should be understood that several aberration sets, corresponding to several similar projection systems or lenses, may be defined in step (D4). In that way, it may be possible to model the drift of lens aberrations over time and to account for this drift in optimizing the conditions of illumination. More importantly, it may also be possible with this embodiment of the present invention to account for the distribution of lithographic apparatuses (and therefore aberrations) in the fab (or those coming from the factory), and therefore to develop a more robust lithographic process.

**[0222]** As also explained previously, each point of the aberration set will have a corresponding RMS value. This value represents the quadratic sum of the coefficients of the Zernike polynomial that is used to simulate the wavefront aberration at this specific point in the field.

**[0223]** Although the set(s) of aberration(s) in step (D4) correspond(s) to aberrations extracted with one or several lenses, it should be understood that the set(s) may be defined differently. In an embodiment of the present invention, the set of aberrations may be defined, for example, to estimate the sensitivity of a particular aberration to the illumination conditions. In that case, the set will include typical values of that aberration. In another embodiment, the set may include interesting/important aberrations that specifically influence a particular lithographic process (for example, the lithographic pattern to be printed or the illumination conditions).

**[0224]** The method then proceeds to step (D5), where separate responses are calculated for the individual source points in the grid and for each RMS value of the aberration set. Calculations may be done either with a full resist model, an aerial model or with the other models discussed above. Practically, these simulations may be run with any commercially available simulators such as Prolith™, Solid-C™ or the like. In step (D5), the CD of the studied lithographic pattern is calculated for each source point and for the individual points/aberrations in the field lens (or projection lens). In doing so, a set of CDs for each source point is calculated, each of these CDs corresponding to one aberration. Next, the CDs (obtained with the several points in the field lens) of the calculated pattern are compared to one another in order to estimate the total CD range or, alternatively, the highest CD variation relative to the target CD for each source point. In cases where additional aberration sets (corresponding to other lenses or to aberrations of specific interests as discussed in the previous paragraph) are defined in step (D4), the highest range or the highest CD variation in any of the lenses may be taken into account to determine aberration sensitivity and to select the best conditions of illumination.

**[0225]** It should be understood that it is up to the user

of the present invention to select a method of weighting aberrations in order to find the best conditions of illuminations. Therefore, other ways of weighting aberration sensitivity and selecting the best conditions of illumination may be used in other embodiments of the invention. For example, in an embodiment of the invention the average value of the CD variations may be calculated and used to estimate the aberration sensitivity.

**[0226]** In order to aid in the optimization of the illumination conditions, the results of the calculations may then be visualized by plotting the contour map of the responses as a function of source location.

**[0227]** Referring to FIG. 42, an exemplary embodiment of a contour map obtained in accordance with the embodiment of the present invention shown in FIG. 37 is provided. FIG. 42 corresponds to the upper right of the illuminator at the pupil plane 18. This contour map represents the CD variation due to aberrations as a function of source location. For each source point, the highest CD variation is plotted. In the embodiment of the present invention shown in FIG. 42, calculations are done for three similar lenses and the highest CD variation in any of the lenses is plotted for each source point.

**[0228]** As can be seen in FIG. 42, the area of the illuminator that minimizes aberration sensitivity is located in the lower left part of the illuminator. However, it is also shown that a small s illumination will increase the CD variation due to aberrations. It is expected, therefore, that the best illuminator arrangement will combine a s illumination of at least 0.25, in order to reduce aberration sensitivity, and a CQuad illumination (in order to increase the depth of focus). In this particular trial, an augmentation of the small s illumination can drastically reduce the aberration sensitivity to the illumination conditions while still maintaining a robust process window.

**[0229]** This approach was successfully applied to select the best conditions of illumination for the same lithographic pattern (i.e. a double line structure) printed with a Chromeless Phase Lithography (CPL) mask.

**[0230]** Referring to FIG. 43, this figure shows the variations of  $\text{DOF}@8\%EL$  as a function of source point location. This contour map is obtained using embodiments of the invention illustrated, for example, in FIGS. 13 or 24. As can be seen in this graph, an illumination arrangement providing a tight quasar illumination notably increases the depth of focus of the lithographic process.

**[0231]** Results in terms of CD variation due to aberrations obtained with the embodiment of the present invention shown in FIG. 37 are represented in FIG. 44. The contour map indicates that a quasar arrangement favorably reduces the CD variation due to aberrations. The contour map in FIG. 44 also suggests that a quasar illuminations having poles larger ( $0.85/0.50Q45^\circ$ ) than those initially selected in FIG. 43 ( $0.80/0.50Q30^\circ$ ) may give better results (as it encompasses a larger area where CD variation is zero).

**[0232]** This assumption is corroborated in FIG. 45,

which represents the CD variation of the double line structure as a function of wavefront aberration (in RMS). This figure clearly indicates that aberration sensitivity is notably reduced by using a  $0.85/0.50$  quasar  $45^\circ$  illumination arrangement. For this illumination configuration, CD variation lower than 5 nm can still be obtained even with lens aberrations of up to 60 milliwaves.

**[0233]** FIG. 46 illustrates the variation of the Exposure Latitude as a function of depth of focus for the illumination arrangements used in FIG. 44. As can be seen in this graph, an illumination arrangement having larger poles ( $0.85/0.50$  quasar  $45^\circ$ ) may still give a favorable process window. This arrangement represents a good compromise because it favorably reduces CD variation due to aberrations while still maintaining a good process window.

**[0234]** Referring now to FIG. 47, a method for optimizing the conditions of illumination of a lithographic projection apparatus according to an embodiment of the invention will now be explained. In this embodiment of the invention, optimization of the conditions of illumination is done in order to match the results generally obtained with mask assist feature techniques. In an embodiment of the invention, there is provided a method for optimizing an illumination arrangement providing similar results to those obtained with complex Optical Proximity Correction (OPC). With the embodiment of the present invention represented in FIG. 47, low DOF features can be significantly improved by combining disparate areas of the illuminator without using complex and expensive mask assist features.

**[0235]** Mask assist features or reticle enhancement techniques (RET) have been used extensively to improve the fidelity and manufacturing of small dimension features in integrated circuits. They generally include optical proximity correction (OPC) and phase shift masks (PSM).

**[0236]** OPC involves modification to the design pattern to compensate for changes in feature shape and size that occur during pattern transfer from the reticle to the wafer. When the pattern is transferred from the reticle to the wafer, several effects introduce distortion into the pattern. These distortions include line-width variations dependent on pattern density, corner rounding, and line-end shortening. The changes to the pattern can create bad connections or cause devices to operate at less than optimal speed. Causes for the distortion include reticle pattern infidelity, optical proximity effects, diffraction and interference, and diffusion and loading effects during resist and etch processing.

**[0237]** OPC makes small changes to the IC pattern that are designed to anticipate and correct for these distortions. For example, line end shortening can be corrected by extending the line using a hammerhead shape that results in a line in the resist that more closely resembles the originally intended layout. Corner rounding is corrected by adding (or subtracting) serif shapes from corners.

**[0238]** Phase shift masks take advantage of the interference effect in a coherent or partially coherent imaging system to reduce the spatial frequency of a given object, to enhance its edge contrast, or both. It is possible to control locally the type of interference, destructive or constructive, at critical locations in a design by adding an additional patterned layer of transmitting material on the mask. This technique results in a combination of higher resolution, larger exposure latitude, and larger depth-of-focus. In phase shift lithography, a transparent coating is placed over a transparent area. The light waves passing through the coated region are delayed 180° out of phase with the light waves passing through the uncoated region. At the edge of a phase-shifted area, the light waves from the phase-shifted and clear areas will cancel out producing a more sharply defined interface.

**[0239]** The extension of phase shift windows and optical proximity correction to more complex designs results in a large increase in the complexity of the mask layout. Determining exactly what corrections to make (with OPC or phase shift windows) is an extremely complicated process that depends on neighboring geometries and process parameters. For example, when laying out phase shift windows on dense designs, phase conflicts may occur. In addition, millions of features may be laid out in the design of a single integrated circuit. The burden of data processing resources for iterative operations over such large numbers of features can be huge, and in some cases makes the iterative operation impractical.

**[0240]** In an embodiment of the invention, optimization of the source is achieved with a method including: defining a lithographic pattern to be printed on the substrate; defining mask assist features configured to help print the lithographic pattern on the substrate; selecting a simulation model; selecting a grid of source points in a pupil plane of the illuminator; calculating separate responses for individual source points with and without the mask assist features, each of the responses representing a result of a single or series of simulations using the simulation model; and adjusting an illumination arrangement of the illuminator based on analysis of accumulated results of the separate calculations.

**[0241]** Referring back to FIG. 47, the method for optimizing the conditions of illumination begins in step (E1) where a lithographic problem is defined. The method then proceeds to step (E2) where mask assist features are defined and loaded in the simulator. These mask assist features, which are configured to help printing the pattern on the mask, may include in an embodiment of the present invention Optical Proximity Correction. They may also include in another embodiment of the invention phase shift windows. An example of a mask assist feature is shown in FIG. 48. In this figure, the mask assist feature corresponds to 50 nm anti-scattering bars (ASB) disposed on each side of a 75 nm trench.

**[0242]** Next, the method proceeds from step (E3) to

step (E4). In these steps, a model is chosen to perform the simulations and a grid of source points is selected in the pupil plane of the illuminator.

**[0243]** The method then proceeds to step (E5) where separate responses for individual source points are calculated with and without the mask assist features, each of the responses representing a result of a single or series of simulations using the simulation model. Responses may include depth of focus (DOF), the exposure latitude (EL), the depth of focus at 8% EL (DOF@8%EL), the dose-to-size  $E_{1:1}$ , dense to isolated feature bias, arbitrary feature size biases, sidelobe printing, film loss, sidewall angle, mask error enhancement factor (MEEF), linear resolution, or absolute resolution.

**[0244]** The method ends in step (E6) where an illumination arrangement of the illuminator is selected based on analysis of accumulated results of the separate calculations. More specifically, optimization of the conditions of illumination is performed in an embodiment of the invention by comparing the responses calculated with mask assist features to the responses calculated without mask assist features. Then, the illuminator arrangement is selected by determining the area(s) of the illuminator that give(s) responses as good as or substantially similar to the best responses calculated with mask assist features. This ensures that the resulting illuminator arrangement, which is used to expose the pattern without mask assist feature, will give results at least comparable to those obtained with mask assist features. In this way, it is possible to produce some of the advantages generally obtained via, for example, reticle OPC by applying "assist features" at the illuminator level. Thereby, the need for costly and complex reticles may greatly be reduced.

**[0245]** It should be understood that optimization of the illumination conditions according to the embodiment of FIG. 47, may also be done including some mask assist features of specific interests. In that case, optimization of the illumination arrangement is done by comparing simulation results obtained with and without these mask assist features of specific interests.

**[0246]** It should also be understood that optimization of the illumination conditions is done to make the most cost effective process. Specifically, it should be kept in mind that mask or source "enhancement" is undertaken to produce a reasonable manufacturing yield. Therefore, one may attempt to use a relatively simple illumination with a complicated mask, or alternatively a complex illumination arrangement with a simple mask. In some cases, these two options could be combined (i.e. for a very difficult process). The present invention provides a useful tool to help in deciding the avenue to follow in order to obtain the most cost effective process.

**[0247]** This approach was successfully pursued to select an illumination arrangement that provides similar results to those obtained with the anti-scattering bars in FIG. 48. As explained above, optimization of the conditions of illumination was first done by selecting the best

illumination arrangement using the responses calculated with mask assist features. Selection of the best arrangement was performed with the max DOF and max EL responses. For reference, the variation of these two responses as a function of source point position is represented in FIGS. 49a and 49b. In this trial, the reticle used is a 6% attenuated phase shift mask, the radiation has a 193 nm wavelength and the exposure is done with a 0.93 numerical aperture.

**[0248]** As can be seen in FIGS. 49a and 49b, a very wide CQuad or quasar arrangement may be desirable to obtain the best condition of illumination. Results for these types of illumination arrangement in terms of Exposure Latitude are represented in FIG. 50. This graph shows the variation of EL as a function of depth of focus for various lengths and sizes of CQuad poles (the length being expressed in arc degree) and for various Anti-Scattering Bar pitches. This graph shows that the best illumination arrangement and the best lithographic process may be attained with ASB disposed in a 160nm pitch and exposed with 22.5 °CQuad poles. In this trial, a 10 nm and 20 nm positive bias, corresponding to a size of the trench of 85 nm and 95 nm respectively, is applied on the mask.

**[0249]** After finding the best illumination and ASB arrangement, the optimization of the condition of illumination according to an embodiment of the invention shown in FIG. 47 proceeds by calculating the same responses without mask assist features. These results are illustrated in FIGS. 51 a and 51b, which represent the variation of these responses as a function of source point location. Calculation of the separate responses for individual source points and determination of the contour map may be done with the embodiments of the present invention represented, for example, in FIGS. 13 and 18. As can be seen in these figures, the DOF response suggests that a CQuad illumination may be desirable to obtain a good process window. By contrast, the EL response indicates that a small sigma illumination may be best for this lithographic problem. It is therefore expected that a small sigma illumination combined with a wide CQuad illumination would constitute the best illumination arrangement to obtain a large process window.

**[0250]** In this particular case, selection of the size of the poles in the CQuad illumination and the size of the s illumination was determined by isofocal compensation analysis according to the embodiment of the present invention illustrated in FIG. 24. That is, the sizes of the CQuad and s spots are selected so that the resulting lithographic process is rendered substantially isofocal. By doing so, CD variations within the process window are drastically reduced, a substantial isofocal process over the predetermined range of focus may be obtained, and the focus range (DOF) over which the CDs remain acceptable is augmented.

**[0251]** Using isofocal compensation analysis, it is concluded that one can match at least the results obtained with mask assist features by selecting a

35°CQuad illumination with a 0.1s illumination. As can be seen in FIG. 52, the CD variation of the trench with this illumination arrangement is relatively stable over a predetermined range of focus. For reference, the cross section of the resulting beam intensity at the pupil plane of the illuminator is represented in this figure.

**[0252]** It should be noted that it may be desirable in some cases to reduce the intensity of the illumination from small poles in order to optimize the conditions of illumination. For example, it is possible to obtain the required "isofocal balance" without resorting to unrealistic small pole sizes. This may be achieved by reducing the intensity of the pole while increasing its size.

**[0253]** Referring now to FIG. 53, this graph shows the variation of exposure latitude as a function of depth of focus for the best lithographic process determined with mask assist feature and for an alternative process that does not use assist features but which has been developed to give very good results. As can be seen in this graph, the lithographic process developed without mask assist features gives better results than the process developed with mask assist features. These results show that it is possible to replicate the positive effects obtained with mask assist features by selecting an appropriate illumination arrangement in accordance with the method of the present invention shown, for example, in FIGS 13 and 18. It is therefore concluded that by selecting an appropriate illuminator arrangement with the embodiment of the present invention shown in FIG. 47, one can quickly develop a lithographic process that gives good results without using mask assist features. With the embodiment of the invention shown in FIG. 47, the "assist features" are applied in the illuminator and the need of complex and-expensive reticles to print sub 150 nm patterns may be obviated.

**[0254]** It should be noted that by using a "simple mask /complex illuminator" approach as shown in FIG. 47, it is possible to reduce the pattern bias on the mask and, therefore, to increase the depth of focus of the lithographic process. Thus, as there are no assist features present on the mask, there is no risk of opening them by using high exposure energies. It is therefore now possible to use high doses with low bias to improve the process window. To illustrate this principle, reference is made to FIG. 54. This graph shows the variation of the exposure latitude as a function of depth of focus for various biases. As can be seen in this graph, it is possible to increase the depth of focus with a -5nm bias (corresponding to a 70 nm trench on mask).

**[0255]** Referring now to FIG. 55, a method for optimizing the conditions of illumination of a lithographic projection apparatus according to an embodiment of the invention will now be explained. In this embodiment of the invention, optimization of the illumination is performed using a best CDU (Critical Dimension Uniformity) metric. More particularly, the critical dimension uniformity of a lithographic pattern is calculated as a function of the source point location, and that information is then used

to select the best condition of illumination.

**[0256]** In this embodiment of the invention, optimization of the source using best CDU metric is achieved with a method including: defining a lithographic pattern to be printed on the substrate; selecting a simulation model; selecting a grid of source points in a pupil plane of the illuminator; defining a plurality of parameters and their range of variation; calculating separate responses for the individual points and for each of the plurality of parameters, each of the responses representing a result of a single or series of simulations using the simulation model; calculating a metric representing a CD variation of the lithographic pattern for the plurality of parameters and for the individual source points; and adjusting an illumination arrangement based on analysis of the metric. In this embodiment of the present invention, optimization of the conditions of illumination is performed to maximize the critical dimension uniformity (CDU) of the lithographic pattern. This is achieved in an embodiment of the invention by including many important contributors to CD variation when selecting the best illuminator arrangement.

**[0257]** Critical dimensions (CDs), which are used to monitor the pattern size and ensure that it is within the customer's specification, are especially important to have size maintenance during substrate processing. CD uniformity (CDU) refers to when the designed values match the actual values on the substrate, or when the CD's of multiple similar features on the same semiconductor device are identical. CDU is generally considered by process engineers as one of the most direct indicators in determining whether a device will function within specifications.

**[0258]** However, pattern fidelity can deteriorate dramatically in sub-wavelength lithography and the resulting semiconductor features may deviate significantly in size and shape from the ideal pattern drawn by the circuit designer. Given that deviations from the target CD may dramatically affect the product yield and the product performances, it is desirable to account for CDU when selecting the best condition of illumination.

**[0259]** It should be noted that one of the approaches to determine simulated CD uniformity is to use a Monte Carlo method. In this method, all the variables are changed simultaneously with values selected randomly from their assumed (or known) distribution. With the method of the present invention, it is possible to obtain similar results to those obtained with a Monte Carlo calculation.

**[0260]** Referring back to FIG. 55, the method for optimizing the conditions of illumination using best CDU metric begins in step (F1) and proceeds to step (F3). That is, a lithographic problem is defined in step (F1), a simulation model is selected in step (F2) and a grid of source points is generated at the pupil plane of the illuminator in step (F3). Next the method proceeds to step (F4) where a plurality of parameters and their associated variation range are defined and loaded in the simu-

lator.

**[0261]** In the embodiment of the present invention shown in FIG. 55, at least two separate responses are calculated. However, it may be desirable to calculate as many responses as possible for each source point in order to define a good process window. In an embodiment of the present invention, the plurality of parameters may include the focus range ( $\mu\text{m}$ ), the dose range (%), the lens aberrations (RMS in milliwaves), the system flare level (%), the variation of pattern density (%) and the mask CD range (nm). The flare level corresponds to non-image-forming light that reaches the substrate, resulting generally in a loss of contrast in the final image. It should be understood that this list of potential parameters is not exhaustive and that additional parameters may also be included in the calculation.

**[0262]** The method according to the embodiment of the present invention shown in FIG. 55 then proceeds to step (F5) where separate responses are calculated for each source point and for each parameter. In FIG. 55, the calculated response is a critical dimension (CD) of the lithographic pattern defined in (F1). More particularly, the CD variation is calculated for each source point over the predetermined range defined in (F4). In the embodiment of the invention shown in FIG. 55, each of the parameters, i.e. each of the causes of CD variations, are treated independently.

**[0263]** After determining a plurality of CD variation (each of them being obtained by varying the value of the parameters over their predetermined range), the method then proceeds to step (F6) where a metric is calculated. This metric determines the overall CD variation induced by all of the parameters. More particularly, the metric calculates the quadratic sum of the parameters and determines an average CD variation for each source point. The method then ends in step (F7) where an illumination arrangement is adjusted based on analysis of the metric.

**[0264]** It should be understood that it is up to the user of the method of the present invention to determine a way of weighting the CD variation. Therefore, it should be understood that the CD variation for each source point may be determined differently in other embodiments of the invention. For example, in an embodiment of the present invention, the highest CD variation induced by the parameters may represent the CD variation for the studied source point.

**[0265]** The method of optimization according to the embodiment of FIG. 55 was successfully applied to select the best illumination arrangement for the lithographic problem shown in FIG. 56. This problem corresponds to a pattern of 50 nm twin line structures printed with a CPL mask. As can be seen in FIG. 57, calculation of the  $\text{DOF}@8\%EL$  as a function of source point location, according to the embodiment of the invention shown in FIG. 16, indicates that a small quasar illumination may be desirable to print for this specific lithographic pattern.

**[0266]** Referring now to FIG. 58, this contour map il-



illustrates the total CD variation, determined in accordance with the embodiment of the invention shown in FIG. 55, as a function of source point location. This graph suggests that a quasar illumination with large poles (or at least larger than those determined in FIG. 57) may be desirable to lower CD variation.

**[0267]** A comparison of CD variation for different illumination arrangements and for different parameters is shown in FIG. 59. Calculation of the CD variation for each of these arrangements is done with the embodiment of the present invention illustrated in FIG. 55. In FIG. 59, the CDU values were calculated using the actual illuminators depicted. However, the CD value for each arrangement may also be determined by averaging the CD values of each point contained within the illumination spots (similarly to the embodiment of the invention shown in FIG. 18) As can be seen in this graph, the quasar arrangements with poles larger than those determined in FIG. 57 lower the CD variation. More importantly, this graph shows that selecting an illuminator based on the process window alone may not be sufficient to reduce CD variation. It is concluded, therefore, that the best CDU approach defined in the embodiment of the invention of FIG. 55 may be a useful tool to optimize the conditions of illumination for a given lithographic problem.

**[0268]** While specific embodiments of the invention have been described above, it will be appreciated that the invention may be practiced other than as described. The description is not intended to limit the invention.

## Claims

1. A method for optimizing the conditions of illumination of a lithographic apparatus by computer simulation, the lithographic apparatus comprising an illuminator and a projection system, the method comprising:
  - defining a lithographic pattern to be printed on a substrate;
  - selecting a simulation model;
  - selecting a grid of source points in a pupil plane of the illuminator,
  - calculating separate responses for individual source points, each of the responses representing a result of a single or series of simulations using the simulation model; and
  - adjusting an illumination arrangement of the illuminator based on analysis of accumulated results of the separate calculations.
2. A method according to claim 1, wherein each of the responses is a focus exposure matrix and results in a process window that includes dose latitude and depth of focus information.
3. A method according to claim 1 or 2, further comprising calculating a response of trial illumination schemes by averaging separate responses for the individual source points contained within the illumination arrangement.
4. A method according to claim 3, further comprising applying a dose weighted averaging of the responses.
5. A method according to claim 1, 2, 3 or 4, wherein the response is E 1: 1, dense to isolated feature bias, arbitrary feature size biases, sidelobe printing, film loss, sidewall angle, mask error enhancement factor, linear resolution, or absolute resolution.
6. A method according to claim 1, 2, 3, 4 or 5, further comprising mapping the responses as a function of individual source point positions.
7. A method according to any one of the preceding claims, wherein a spacing of the grid is within a range from 0.01 to 0.2.
8. A method according to any one of the preceding claims, wherein the simulated grid is interpolated to increase the grid point density to aid in averaging.
9. A method according to any one of the preceding claims, wherein adjusting the illumination arrangement includes adjusting the illumination arrangement by varying a position of an axicon/zoom module relative to a pyramidal prism, a position of a diffractive optical element, a position of an aperture blade, or by adjusting a programmable mirror array.
10. A method according to any one of the preceding claims, wherein adjusting the illumination arrangement includes selecting a multipole illuminator arrangement.
11. A method according to any one of the preceding claims, wherein adjusting the illumination arrangement includes defining an illumination arrangement with a multipole generating element.
12. A method according to any one of the preceding claims, wherein selecting a simulation model comprises choosing a resist process to be used to print the pattern on the substrate.
13. A method according to claim 12, wherein the resist model is a calibrated model capable of adequately predicting experimental results.
14. A method according to claim 12, wherein defining the resist model includes defining a resist model taking into account at least one of vector effects,

non-zero diffusion of active species, and finite dissolution contrast

15. A method according to any one of the preceding claims, further comprising calculating a metric representing variation of the separate responses for individual source points with defocus and wherein adjusting the illumination arrangement comprises adjusting the illumination arrangement based on analysis of the metric.
16. A method according to claim 15, wherein calculating the metric comprises:
- applying a defocus;
- calculating separate defocus responses for the individual source points at the defocus, each of the defocus responses representing a result of a single or series of simulations using the simulation model; and
- comparing the separate responses with the separate defocus responses for individual source points.
17. A method according to claim 16, wherein the comparing comprises determining separate metric responses for individual source points.
18. A method according to claim 17, wherein the separate metric responses correspond either to an augmentation of the value of the defocus response or a diminution of the value of the defocus response.
19. A method according to claim 17, wherein the determining comprises subtracting the separate defocus responses from the separate responses for individual source points.
20. A method according to claim 17, wherein adjusting the illumination arrangement comprises mapping the metric responses as a function of individual source point positions.
21. A method according to claim 18, wherein adjusting the illumination arrangement comprises selecting an illumination arrangement capturing source points having opposite metric response behaviors.
22. A method according to any one of claims 15 to 21, wherein the defocus is within a range from 0.02 to 0.4 $\mu$ m.
23. A method according to any one of claims 15 to 22, wherein selecting a simulation model comprises selecting one of a full resist model, an aerial image model, a lumped parameter model and a variable threshold resist model.

24. A method according to claim 23, wherein the resist model is a calibrated model capable of adequately predicting experimental results.

- 5 25. A method according to claim 24, wherein the resist model includes defining a resist model taking into account at least one of vector effects, non-zero diffusion of active species, and finite dissolution contrast.
- 10 26. A method according to any one of claims 15 to 25, wherein the separate responses comprise one of a critical dimension of the pattern and an intensity threshold.
- 15 27. A method according to any one of claims 15 to 26, wherein adjusting the illumination arrangement comprises selecting an illumination arrangement so that the variation of the separate responses is minimized or reduced through defocus.
- 20 28. A method according to any one of claims 15 to 27, further comprising calculating other separate responses for individual source points, each of the other responses representing a result of a single or series of simulation using the simulation model.
- 25 29. A method according to claim 28, wherein adjusting the illumination arrangement comprises adjusting an illumination arrangement based on analysis of the other separate responses.
- 30 30. A method according to claim 28 or 29, wherein the other responses comprise one of exposure latitude, depth of focus, E1:1, dense to isolated features bias, arbitrary feature biases, sidelobe printing, film loss, sidewall angle, mask error enhancement factor, linear resolution and absolute resolution.
- 35 31. A method according to claim 28, 29 or 30, further comprising mapping the other separate responses as a function of individual source point positions.
- 40 32. A method according to any one of claims 15 to 31, further comprising mapping the variation of the separate responses as a function of individual source point positions.
- 45 33. A method according to any one of claims 15 to 32, wherein a spacing of the source point in the grid is within a range from 0.01 to 0.2.
- 50 34. A method according to any one of claims 15 to 33, wherein adjusting the illumination arrangement includes varying a position of an axicon/zoom module relative to a pyramidal prism, a position of a diffractive optical element, a position of an aperture blade, or by adjusting a programmable mirror array.
- 55

35. A method according to any one of claims 15 to 34, wherein adjusting the illumination arrangement includes selecting a multipole illuminator arrangement.
36. A method according to any one of the preceding claims, further comprising defining at least one aberration set for the projection system and wherein calculating separate responses for individual source points comprises calculating separate responses for individual source points and for the at least one aberration set.
37. A method according to claim 36, wherein calculating separate responses for individual source points and for the at least one aberration set comprises calculating for each, source point separate responses with the aberration set
38. A method according to claim 37, further comprising comparing for each source point the separate responses and determining the greatest one.
39. A method according to claim 38, wherein the response is a CD variation of the lithographic pattern.
40. A method according to claim 39, further comprising mapping the greatest CD variation as a function of individual source point positions.
41. A method according to any one of claims 36 to 40, wherein the at least one aberration set comprise aberrations that are located in separate positions in a field of the projection system.
42. A method according to claim 41, wherein the aberration set is an aberration set from or representative of a real optical system.
43. A method according to claim 41 or 42, wherein the aberrations are considered together as an overall wavefront error.
44. A method according to any one of claims 36 to 43, wherein defining at least one aberration set for the projection system comprises defining a plurality of aberration sets, each set corresponding to an aberration set from or representative of a real projection system.
45. A method according to any one of the preceding claims, further comprising defining mask assist features configure to help print the lithographic pattern on the substrate and wherein calculating separate responses for individual source points comprises calculating separate responses for individual source points with and without mask assist features.
46. A method according to claim 45, wherein adjusting the illumination arrangement comprises selecting the source points in the grid that give responses, calculated without mask assist features, substantially similar to the best responses calculated with mask assist features.
47. A method according to claim 45, wherein the mask assist features are one of optical proximity corrections, anti-scattering bars and phase shift windows provided on the mask.
48. A method according to any one of the preceding claims, further comprising defining a plurality of parameters and their associated variation range and calculating a metric representing CD variation of the lithographic pattern for the plurality of parameters and for the individual source points and wherein calculating separate responses for individual source points comprises calculating separate CD variations for individual source points and for each of the plurality of parameters.
49. A method according to claim 48, wherein adjusting the illumination arrangement comprises adjusting the illumination arrangement based on analysis of the metric.
50. A method according to claim 48 or 49, wherein the CD variations for each of the plurality of parameters are treated as independent variations.
51. A method according to claim 50, wherein calculating a metric comprises calculating the quadratic sum of the CD variations for each source point.
52. A method according to claim 48, 49, 50 or 51, wherein the plurality of parameters comprise focus range, dose range, lens aberration, flare level, variation of pattern density and mask CD range.
53. A lithographic projection apparatus comprising:
- an illumination system to provide a projection beam of radiation
  - a support structure to support a patterning structure which can be used to pattern the projection beam according to a desired pattern;
  - a substrate table to hold a substrate;
  - a projection system to project the patterned beam onto a target portion of the substrate;
  - a processor to define a lithographic pattern to be printed on the substrate, select a grid of source points in a pupil plane of the illumination system, calculate separate responses for individual source points, each of the responses representing a result of a single or series of simulations using a simulation model, and calcu-

late an optimized illumination arrangement based on analysis of the accumulated results of the separate calculations; and a selectably variable beam controller that is adapted to modify a cross-sectional intensity distribution in the projection beam exiting the illumination system in accordance with the optimized illumination arrangement calculated by the processor.

5

10

**54.** A lithographic projection apparatus according to claim 53, wherein the processor is further configured to calculate a metric representing variation of the separate responses for individual source points with defocus and calculate a metric representing CD variation with a plurality of parameters comprising focus range, dose range, lens aberration, flare level, variation of pattern density and mask CD range.

15

20

**55.** A computer program comprising program code means that, when executed on a computer system, instruct the computer system to perform the method of any one of claims 1 to 52.

25

**56.** A device manufacturing method, comprising:

projecting a patterned beam of radiation onto a target portion of a layer of radiation-sensitive material on a substrate, wherein, prior to impinging the mask, a cross-sectional intensity distribution in the projection beam is optimized using a method according to any one of claims 1 to 52.

30

35

**57.** A method according to claim 56, wherein the adjusting comprises weighing the individual source points.

**58.** A method according to claim 56 or 57, wherein defining at least one aberration set comprises defining one of a representative aberration set and a representative aberration set of specific interest for the projection system.

40

45

50

55

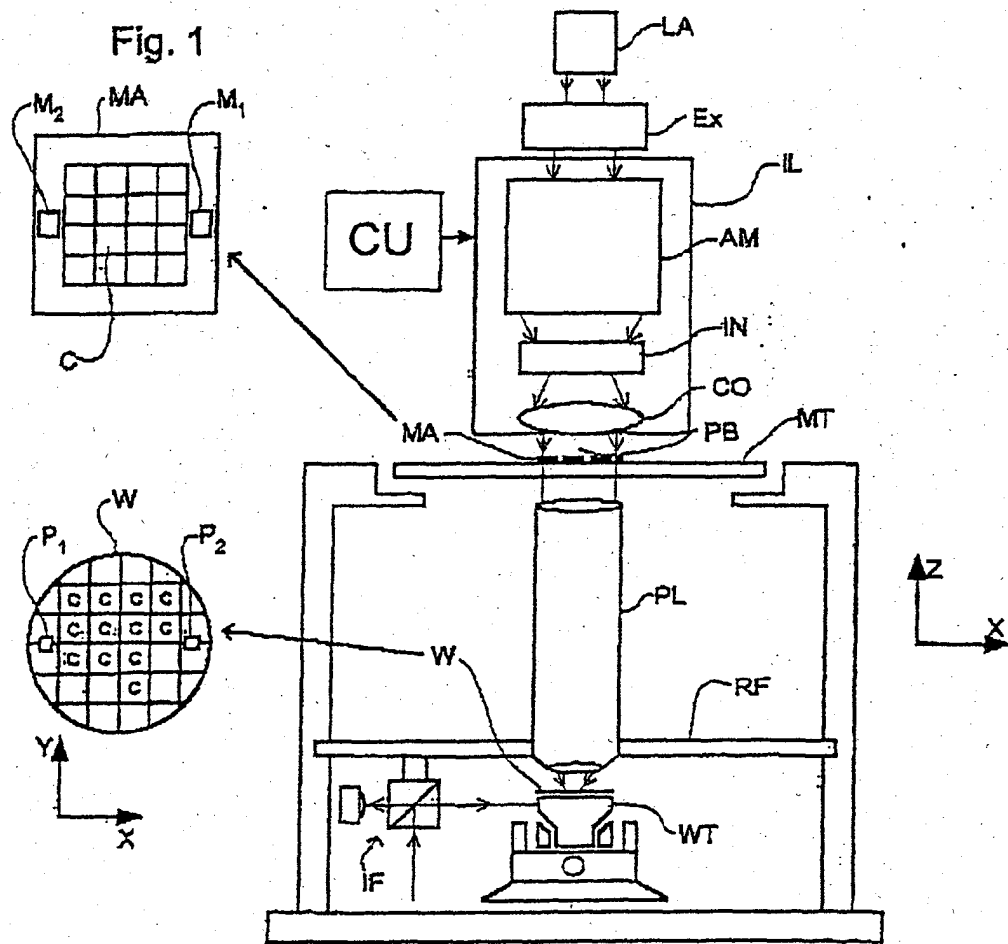

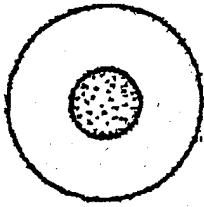

FIG. 2

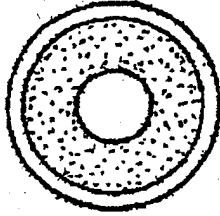

FIG. 3

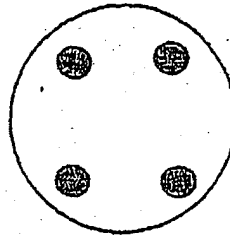

FIG. 4

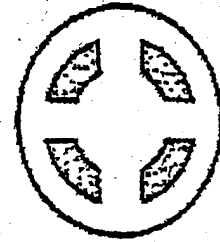
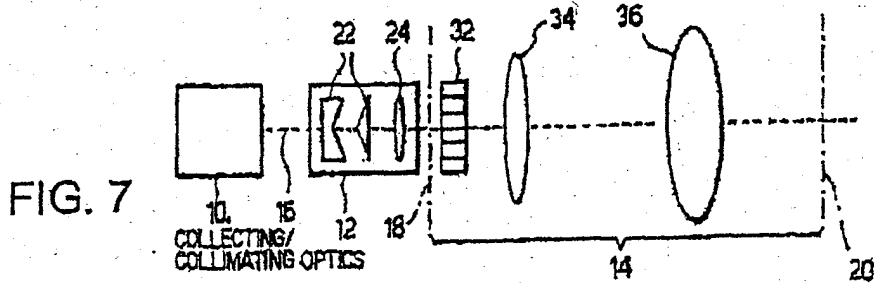
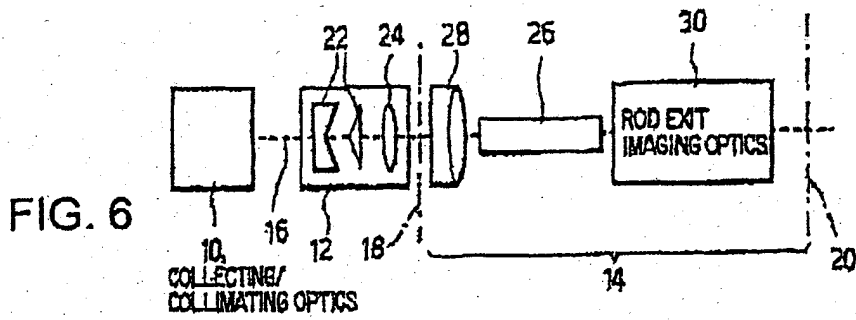
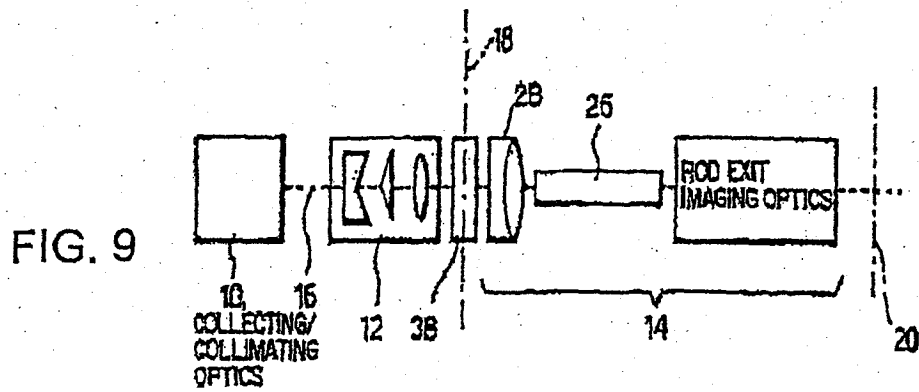
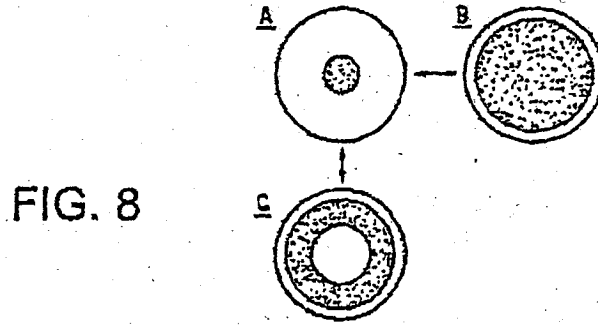

FIG. 5





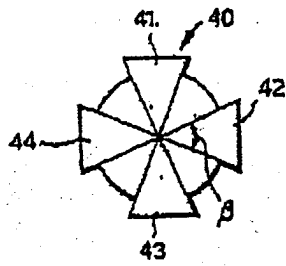

FIG. 10a

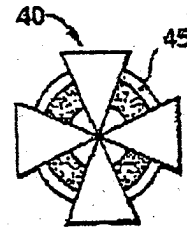

FIG. 10b

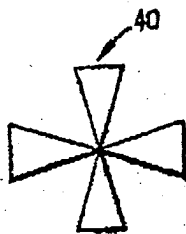

FIG. 11





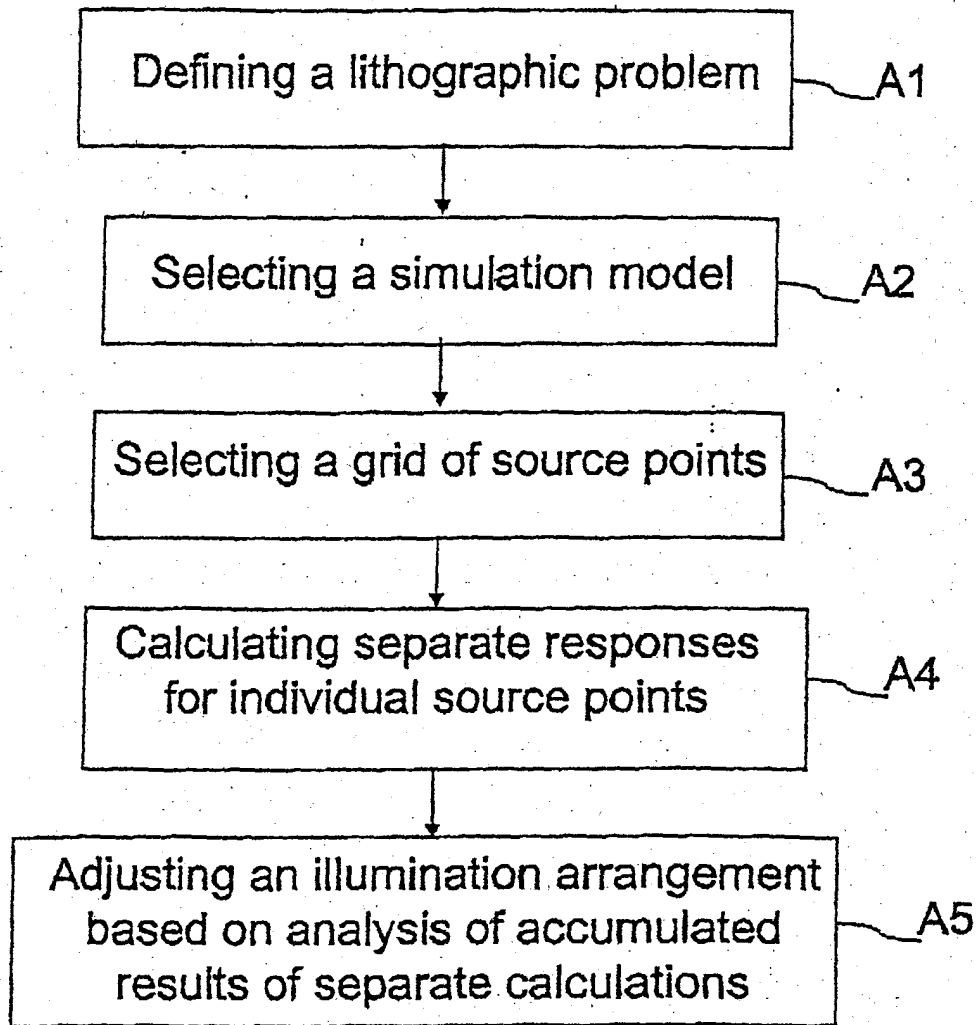

FIG. 13

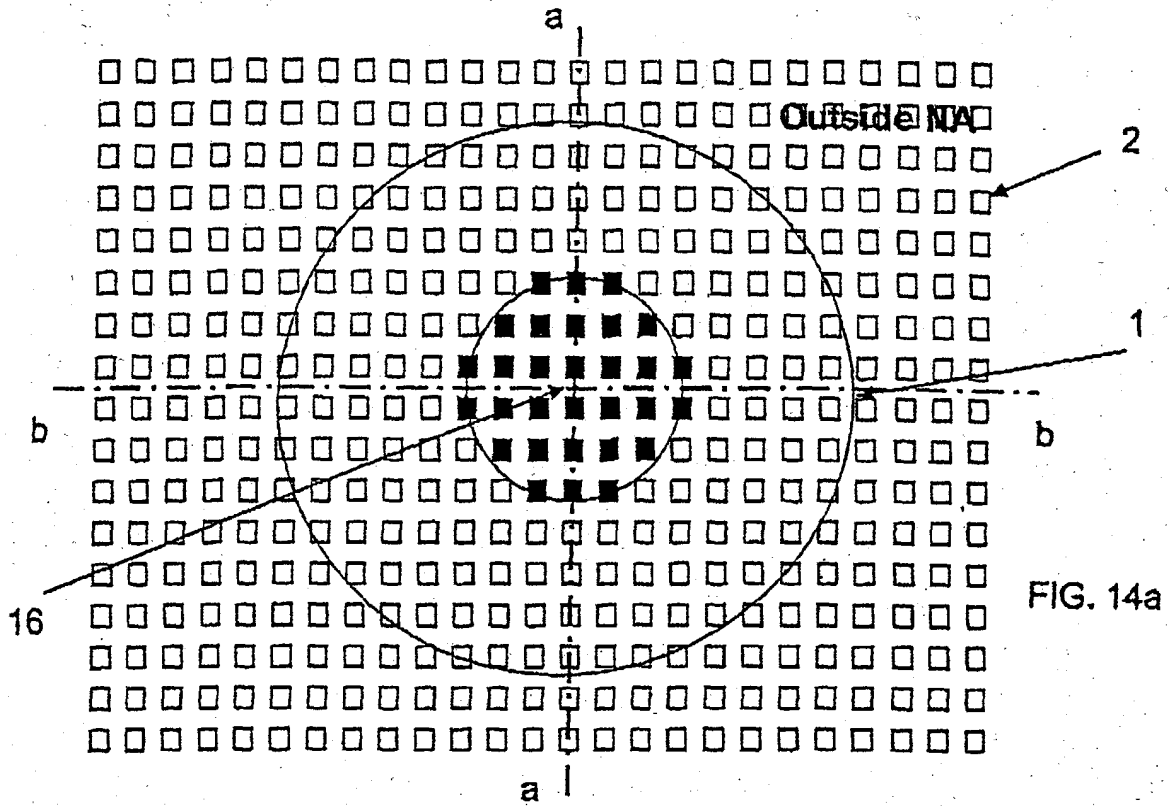

FIG. 14a

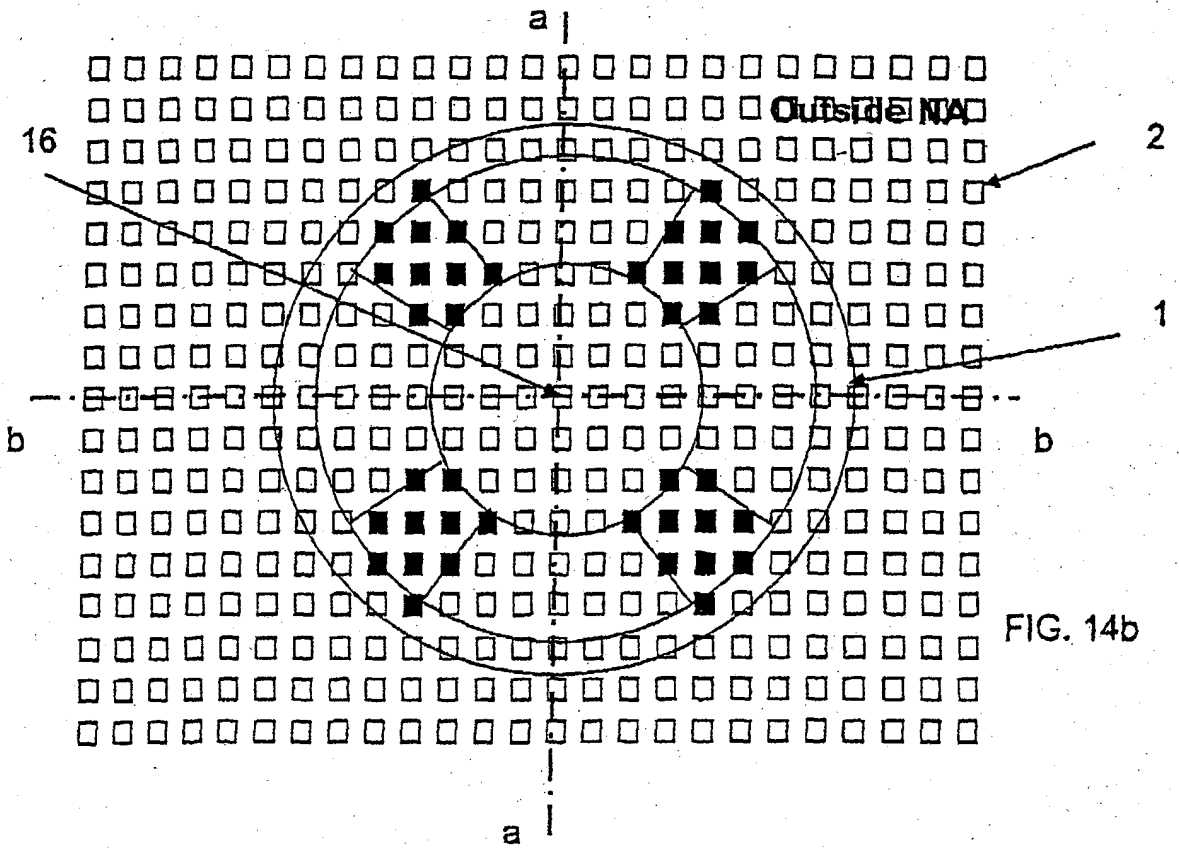

FIG. 14b

65nm CPL isolated lines, 193nm  
0.85NA, scalar aerial image simulations  
0.2 $\mu$ m defocus

High DOF expected with  
appropriate Quasar

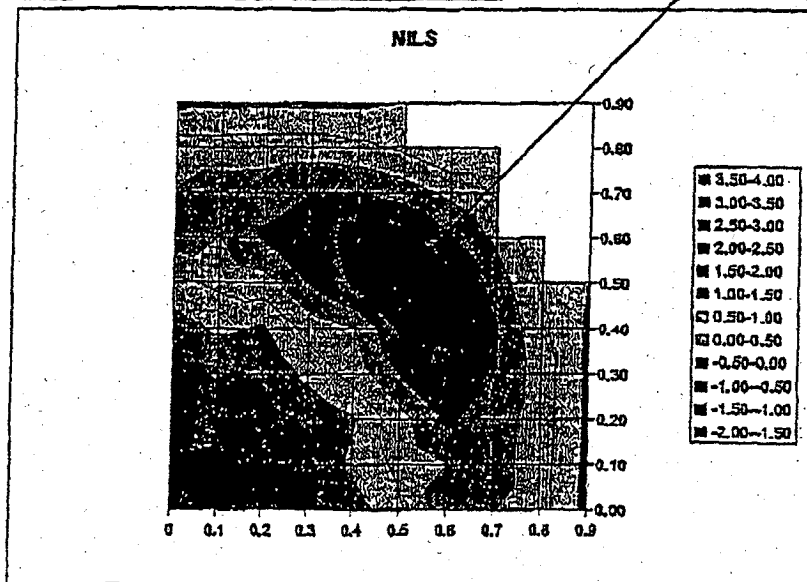

FIG. 15

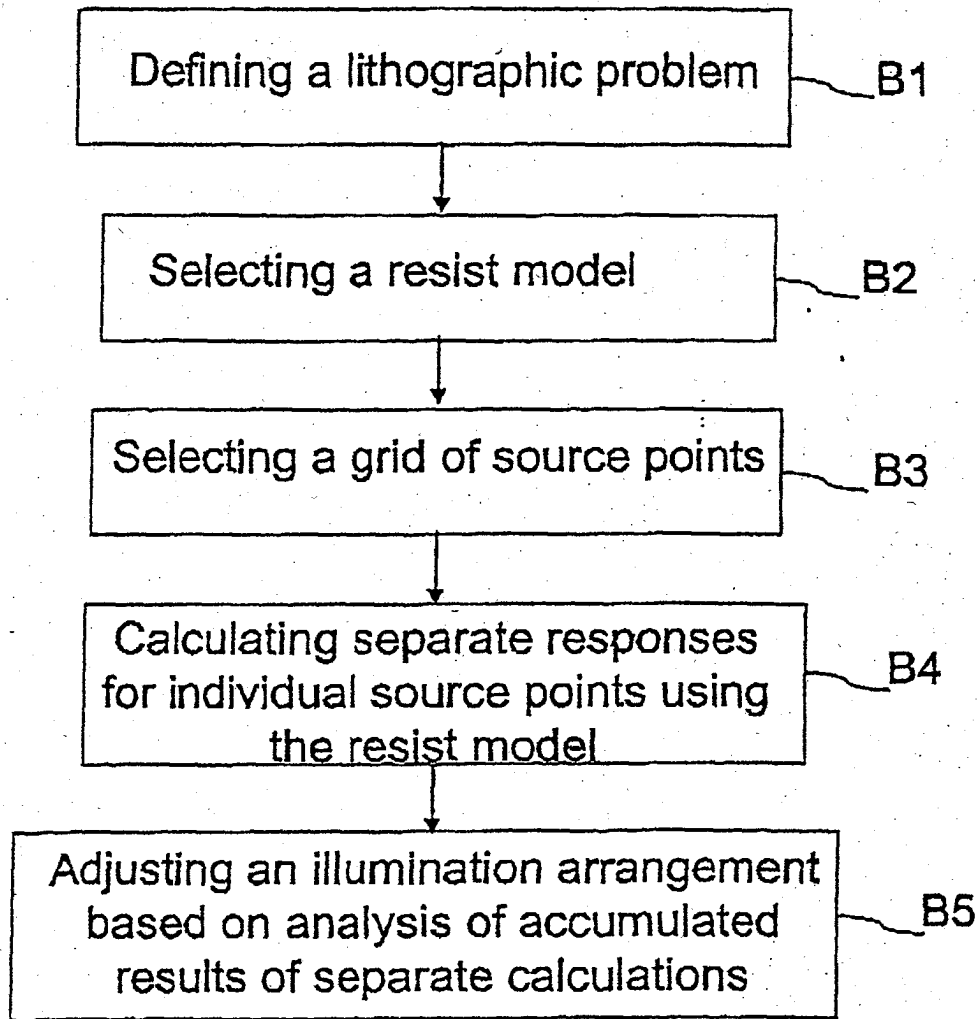

FIG. 16

65nm CPL isolated lines, 193nm  
0.85NA, TOK63 vector resist simulations

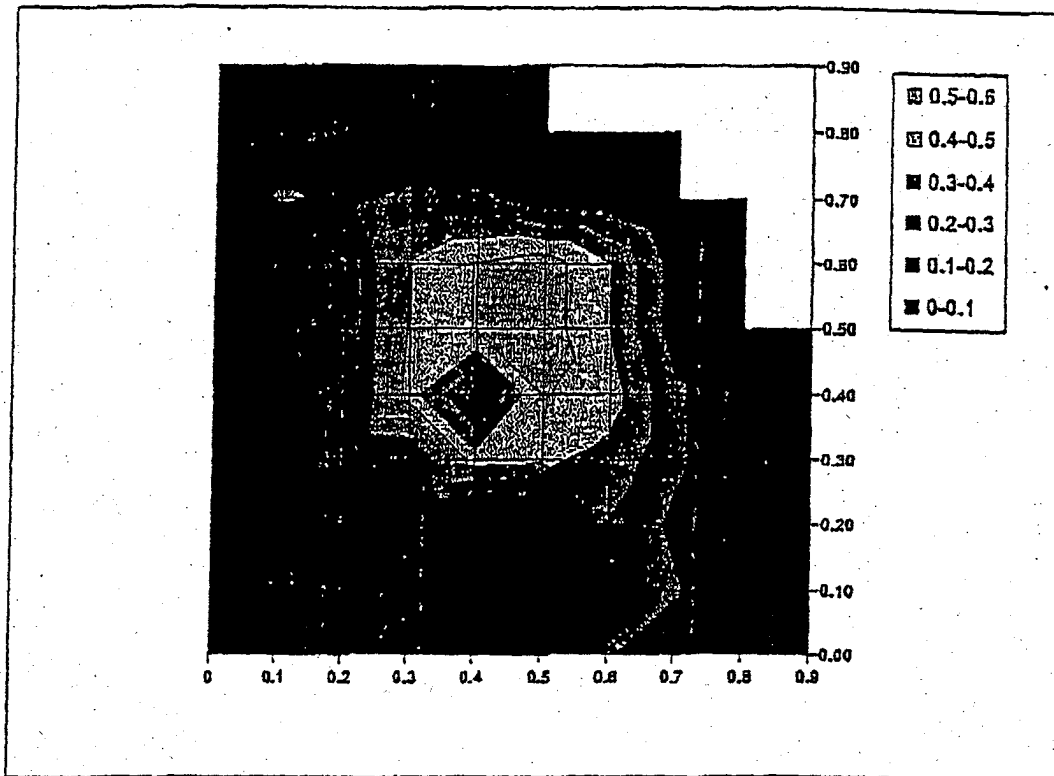

FIG. 17

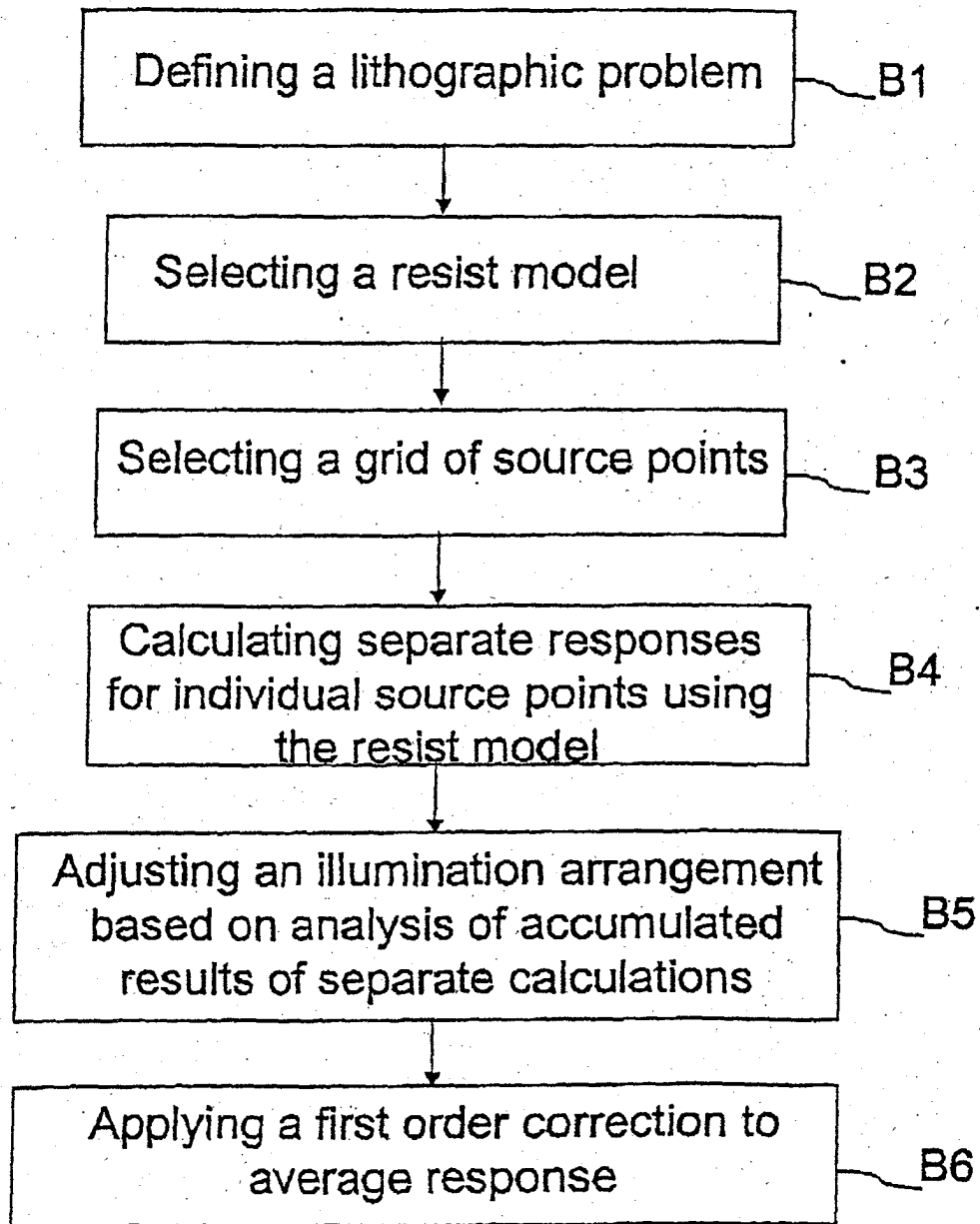

FIG. 18

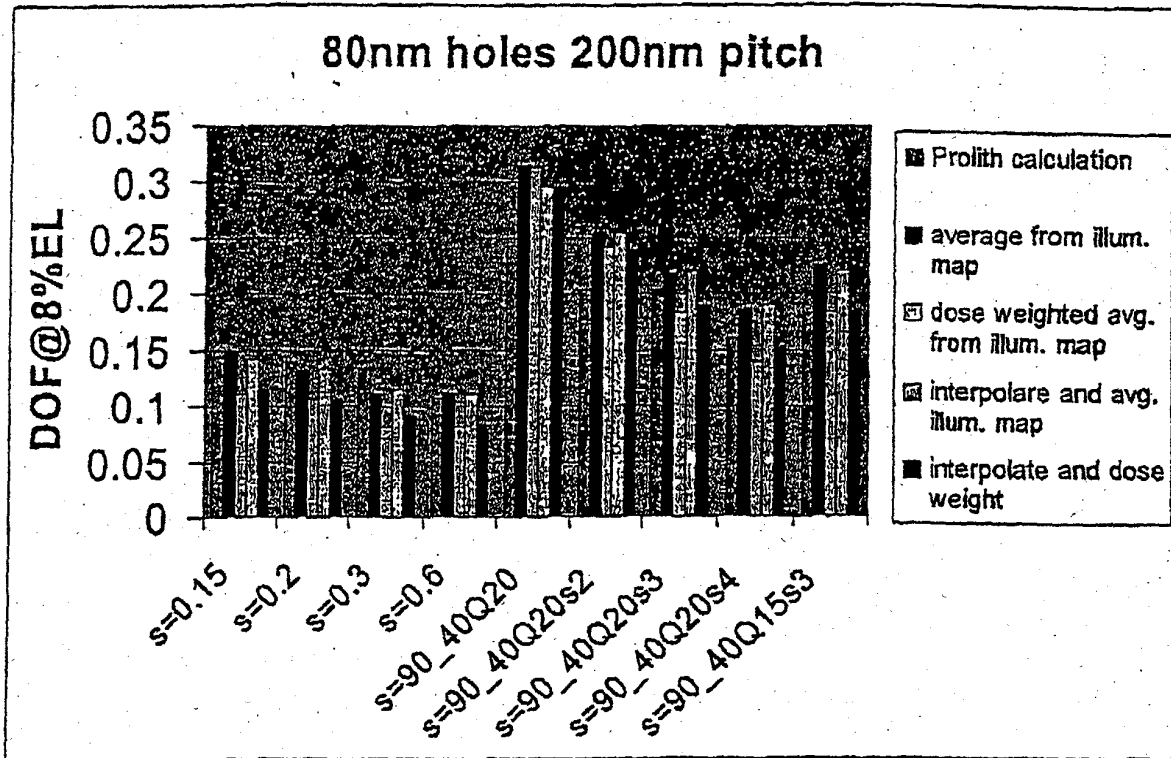

FIG. 19



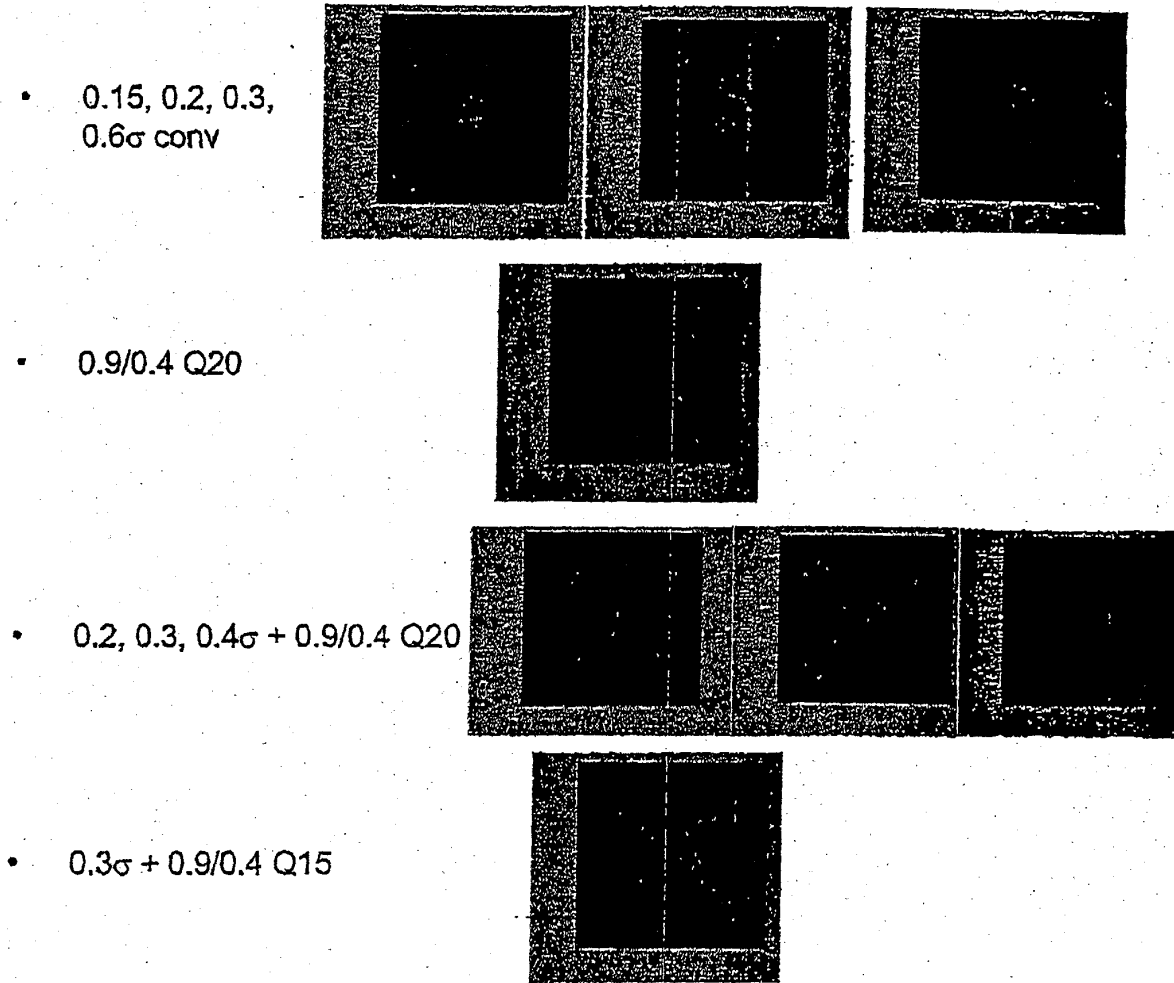

FIG. 20

trial illuminator	prediction based on weighted and interpolated source measurements	Prolith simulation with this illuminator
0.85_0.55Q30	0.293u	0.23u
0.75_0.55Q20	0.416	0.41
0.80_0.60Q20	0.383	0.355
0.80_0.60annular	0.110	0.10
0.75_0.55annular	0.118	0.105

FIG. 21

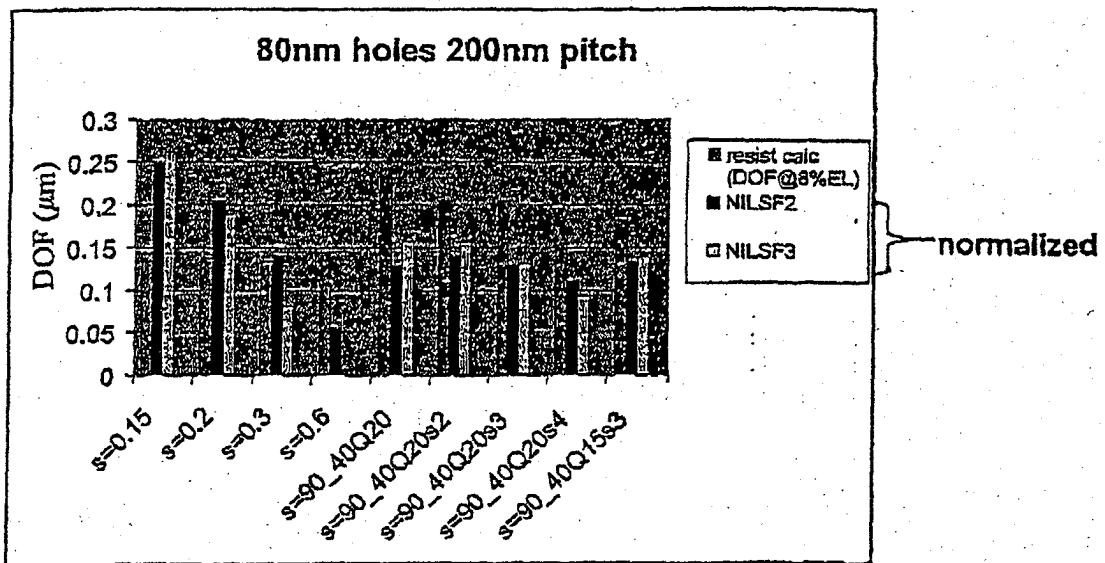

FIG. 22

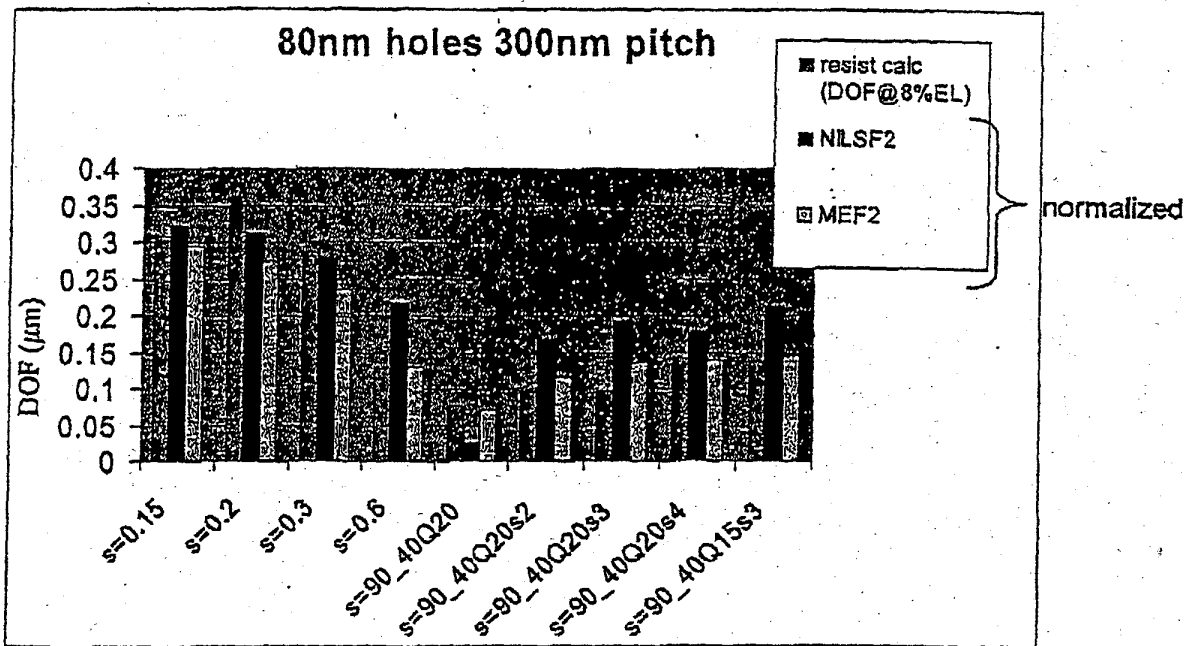

FIG. 23

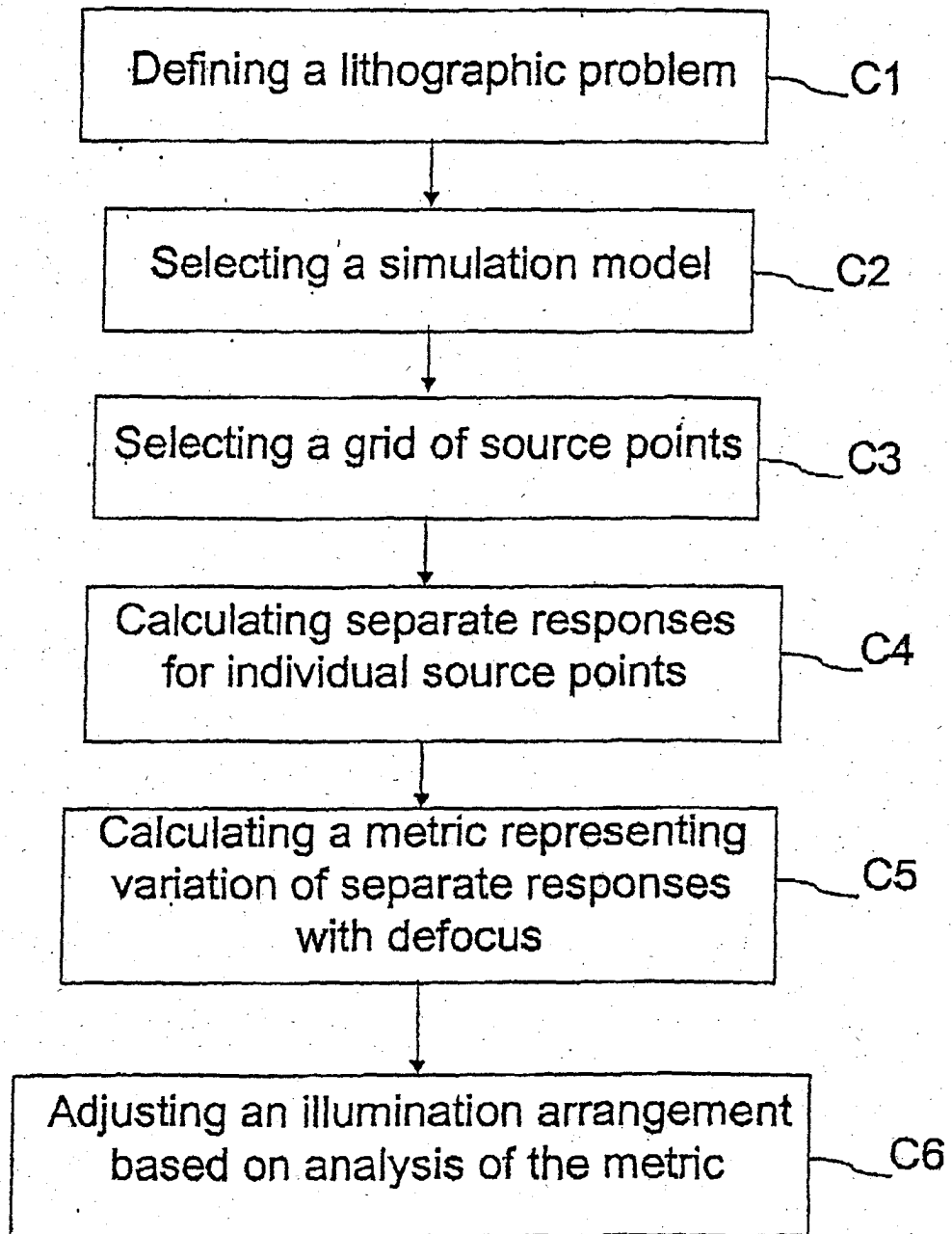

FIG. 24

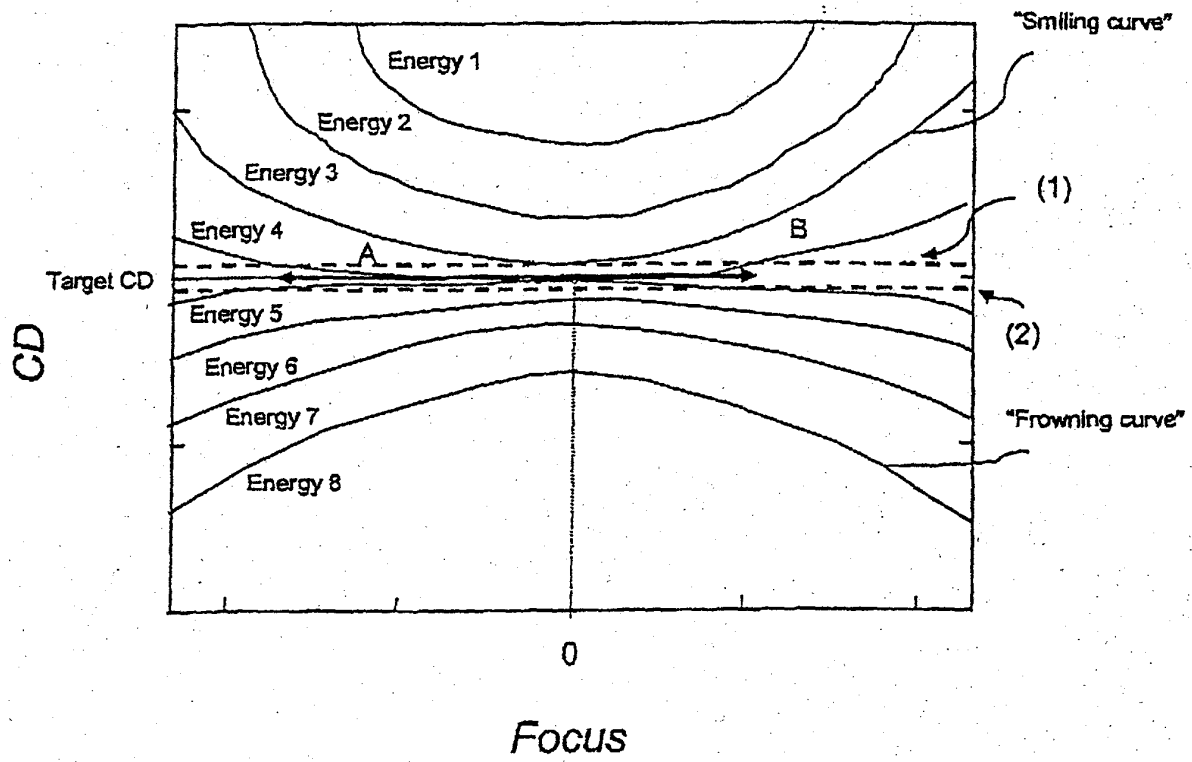

FIG. 25

resist calculation: CD/BF = 2, CD/BF = 2

FIG. 26a

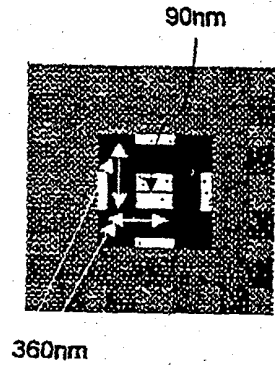
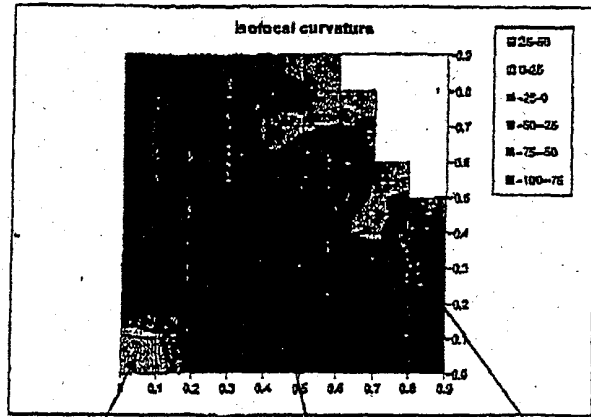

FIG. 26c

Area where Bossung grows smiles  
 $CD = 0.25$   
 $BF = 0$

Area where Bossung grows severely  
 hole closed at 0.25 defects

Area where Bossung grows less severely

Aerial image calculation: thresh(BF) = thresh(BF + 0.2)

FIG. 26b

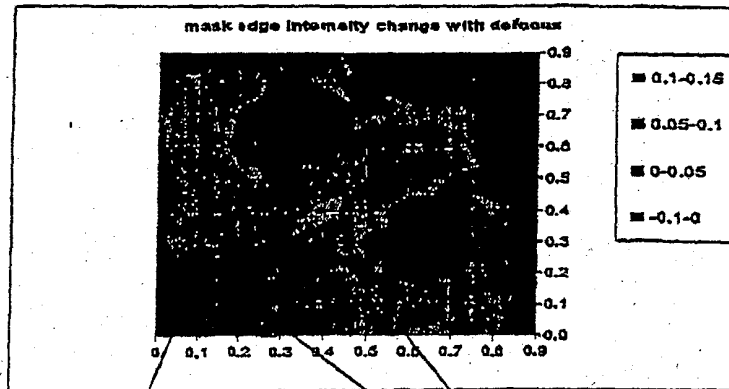

Area where image CD is larger in defocus

Area where image CD is smaller in defocus

mask calculation thresh(BF=0.2) CD(BF)

FIG. 27a

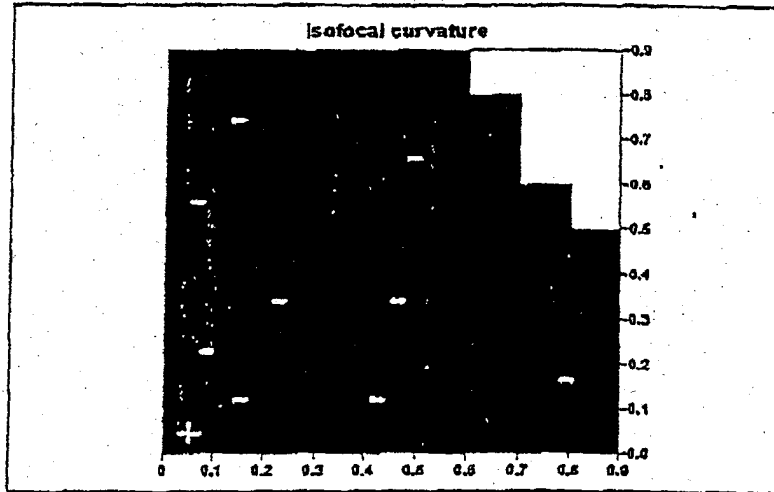

Aerial image calculation thresh(BF) thresh(BF=0.2)

FIG. 27b

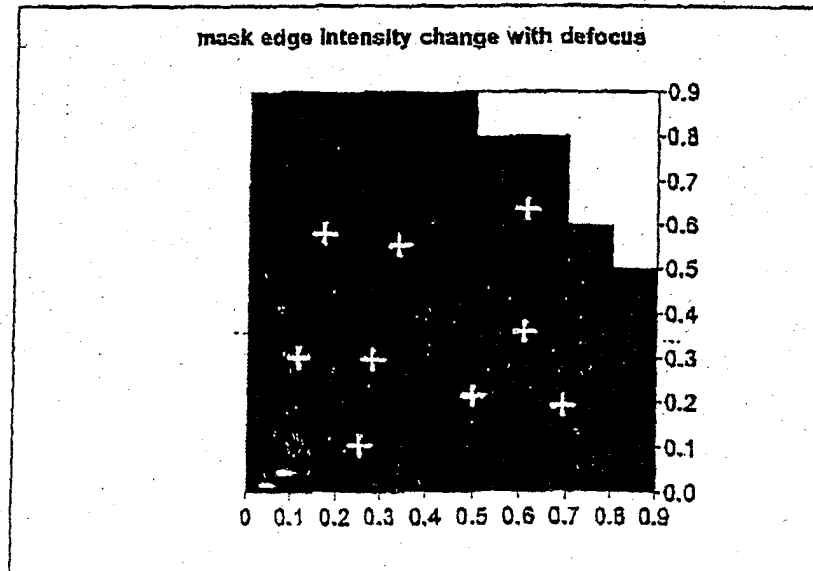
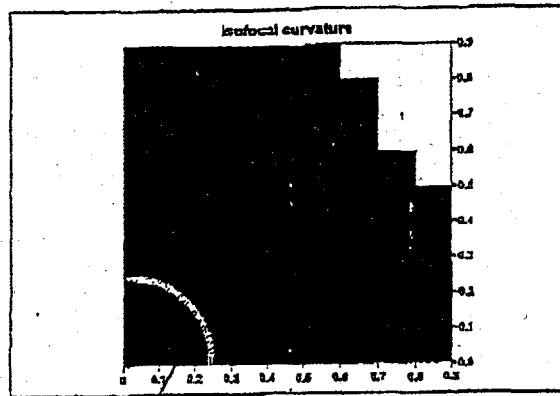



FIG. 28



$\sigma = 0.25$  combines areas of  $\sigma = 0.1$  and  $\sigma = 0.4$  isofocal curvature

$\sigma = 0.25$  process is approximately isofocal  
DOF is good but dose latitude is low

FIG. 29

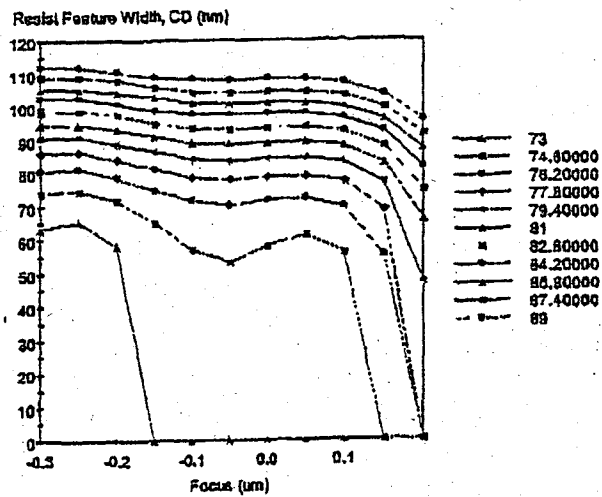

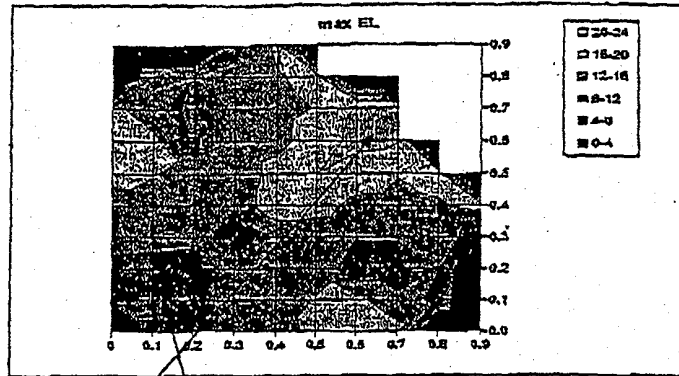

FIG. 30a

Low area provides poor EL and also requires high dose to print (weak aerial image)

Desirable area for high EL is wide quasar

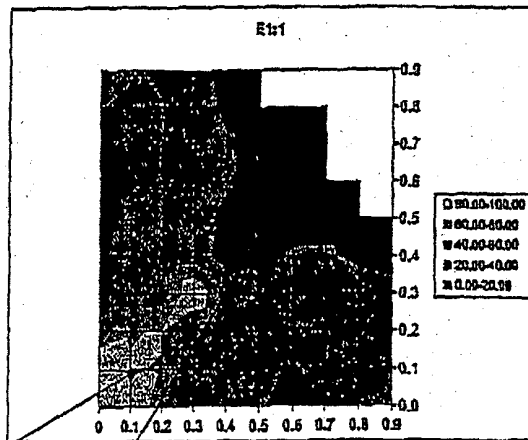

FIG. 30b

Low area provides poor EL and also requires high dose to print (weak aerial image)

Wide quasar also provides low E<sub>t</sub> (strong aerial image)

Illuminator =  $\sigma(0.1 \text{ conv}) + (0.92/0.88Q5^\circ)$

FIG. 31

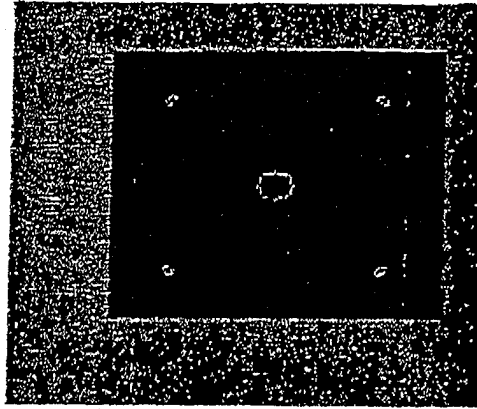

FIG. 32

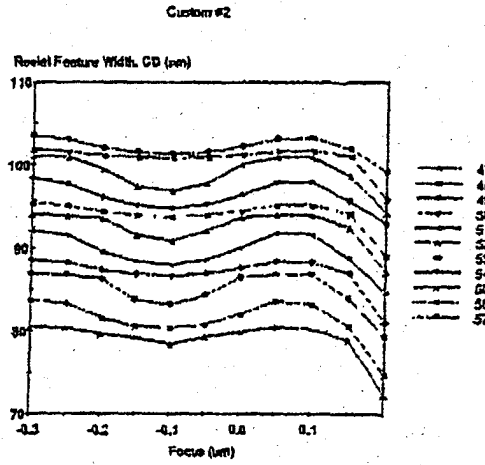
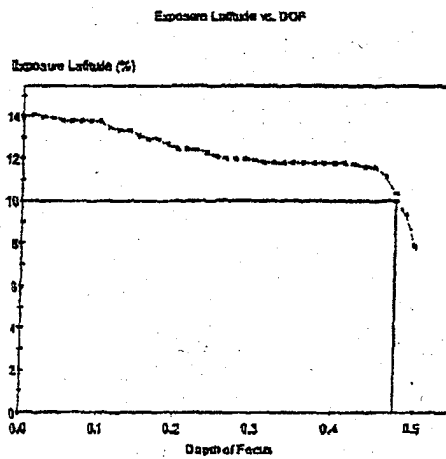

FIG. 33



optimization method	illumination	max EL	max DOF	DOF @ 10% EL	DOF @ 5% EL
standard	0.52/0.70COS <sup>2</sup>	18%	0.3	0.19	0.24
simple isofocal compensation	0.25 conv	8%	>0.58	0	0.29
high EL isofocal compensation	0.52/0.88COS <sup>2</sup> +0.1conv	18%	>0.85	0.87	0.63

FIG. 34

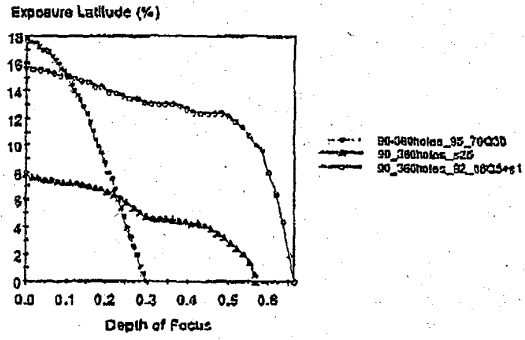
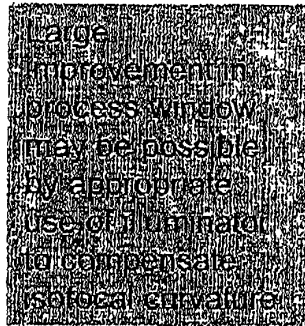

FIG. 35a

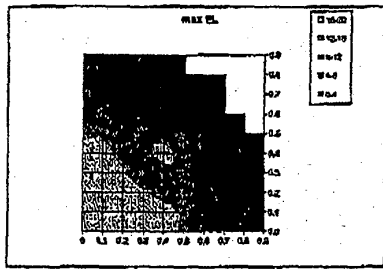

FIG. 35b

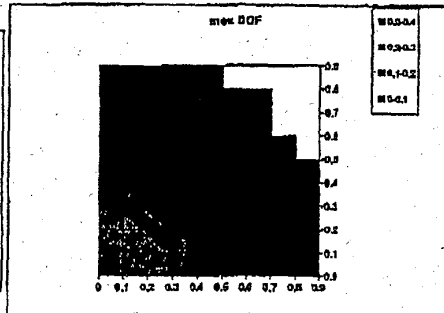

FIG. 35d

FIG. 35c

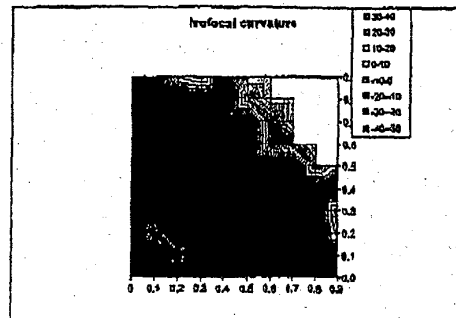
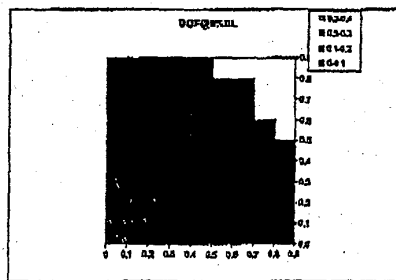

FIG. 36a

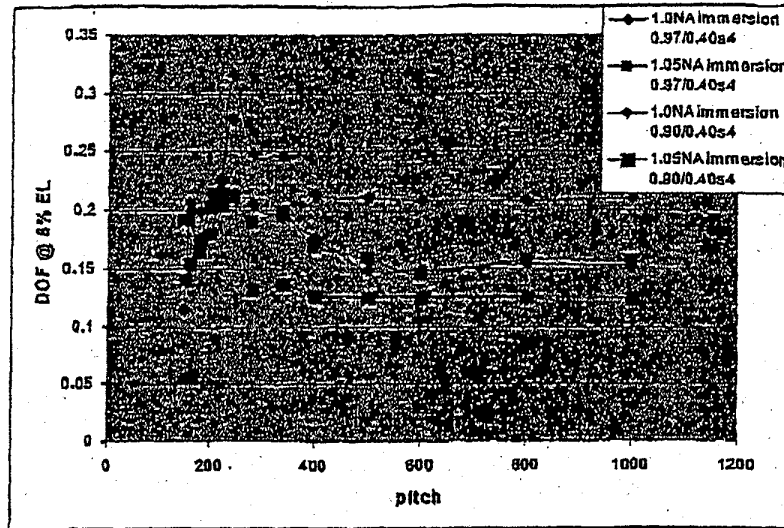
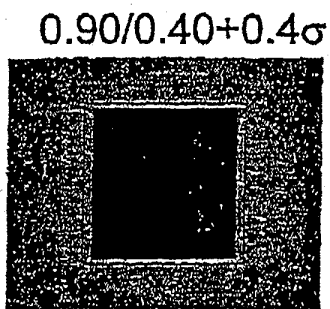

FIG. 36b



0.97/0.40+0.4σ

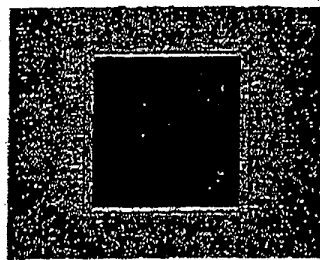

FIG. 36c

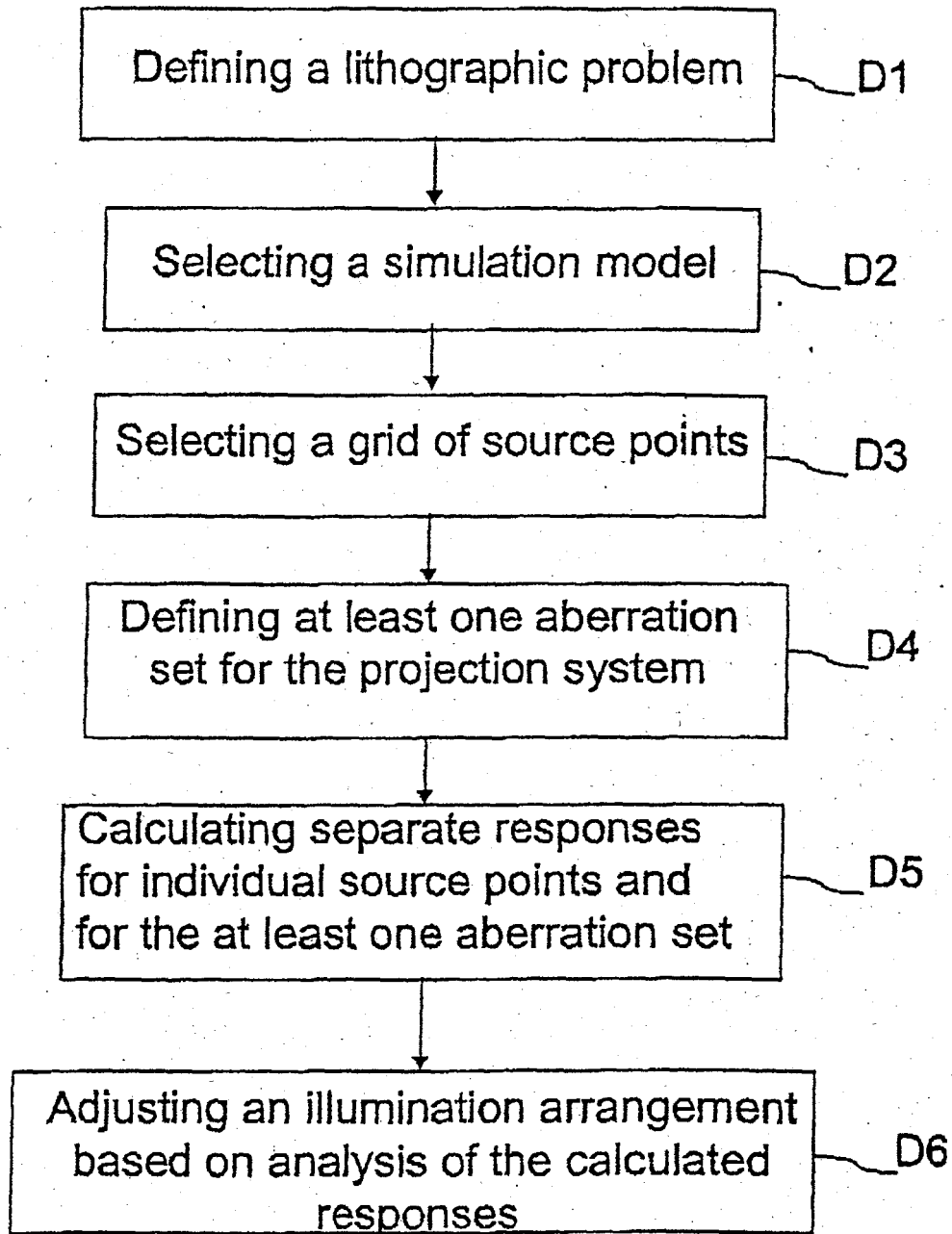

FIG. 37

Under these conditions, the structure  
is very aberration sensitive

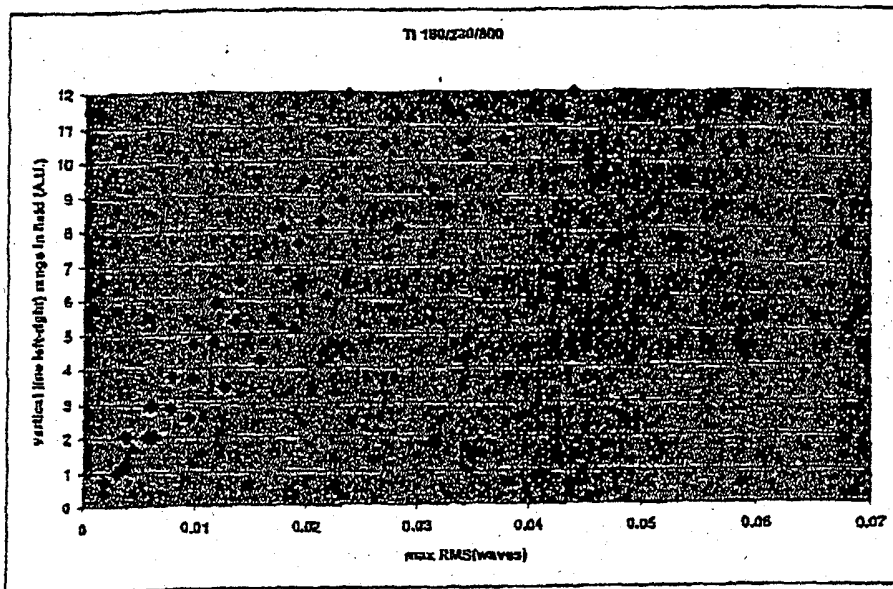
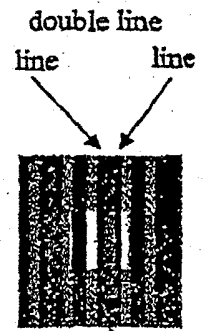

FIG. 38a



PSW  
180 phase  
shift window

FIG. 38b

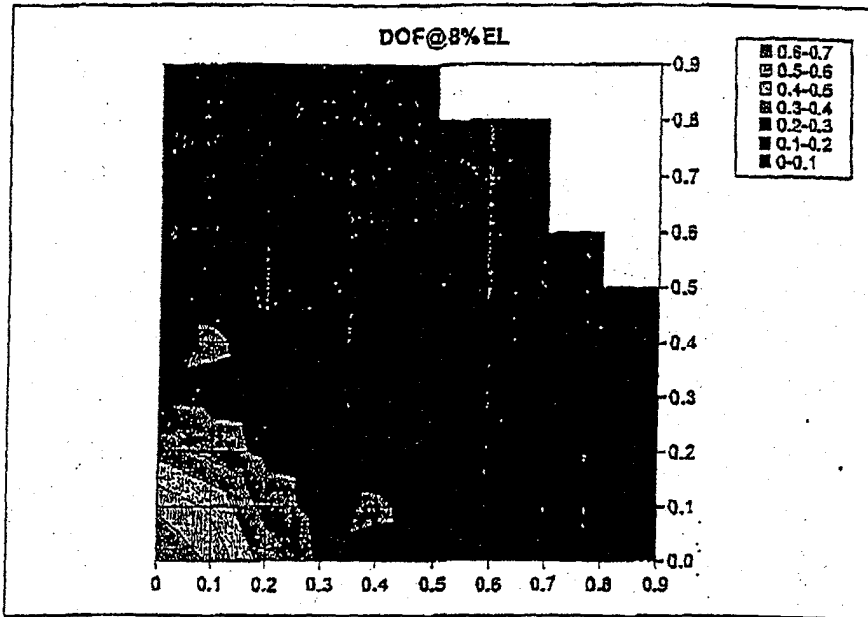

FIG. 39a

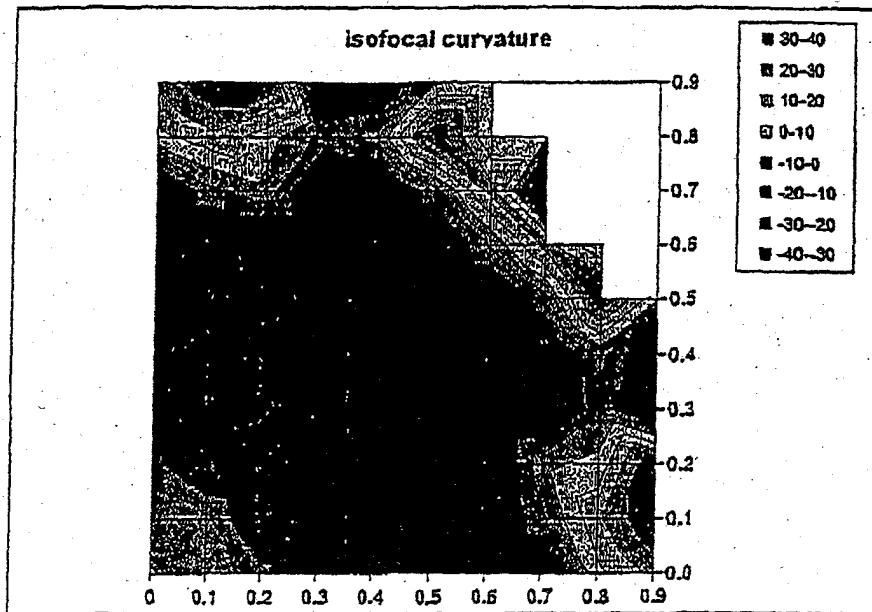
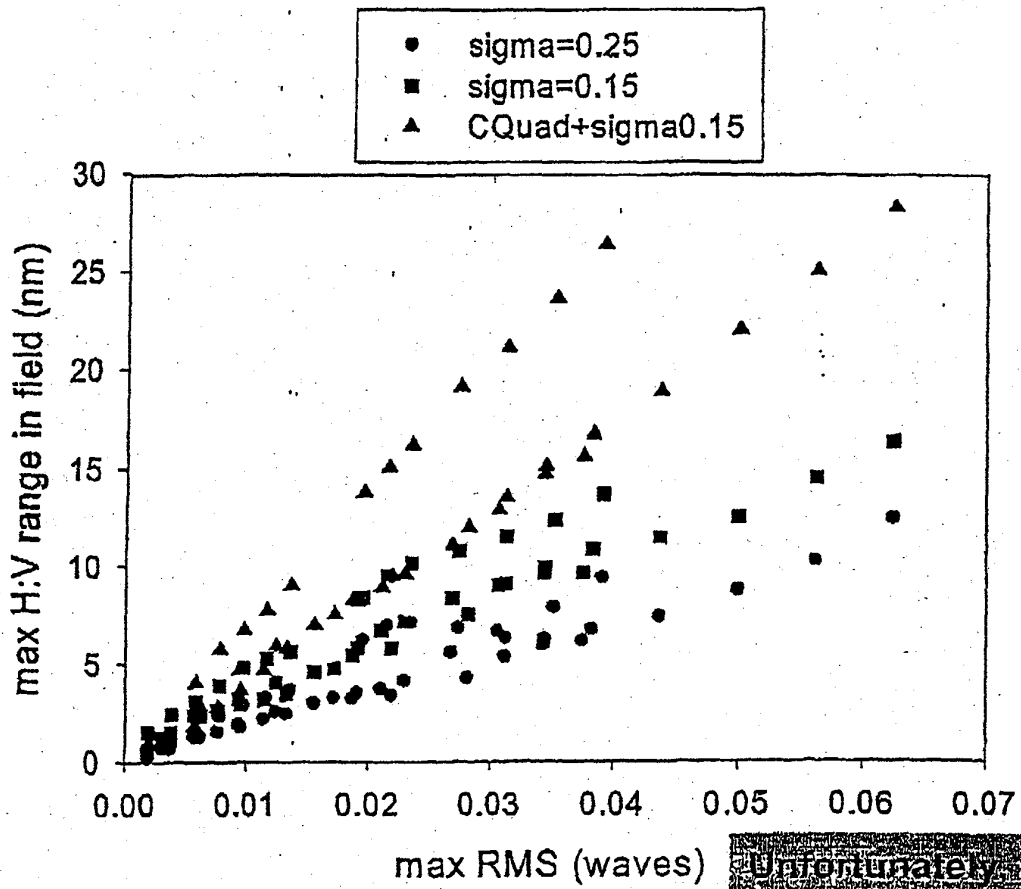

FIG. 39b



Illuminator comparison for double line



Unfortunately, the alternate settings have higher aberration sensitivity.

FIG. 40

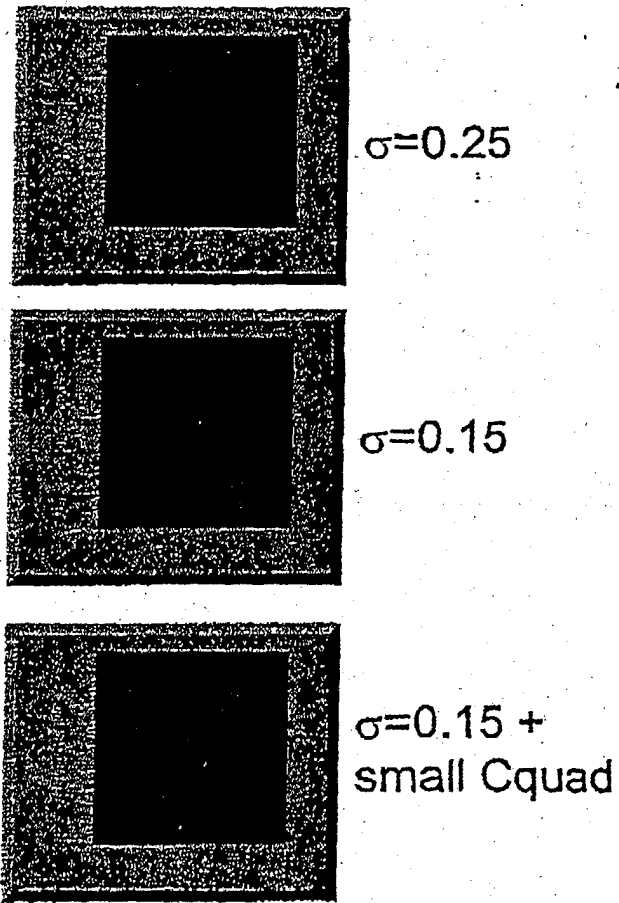

FIG. 41

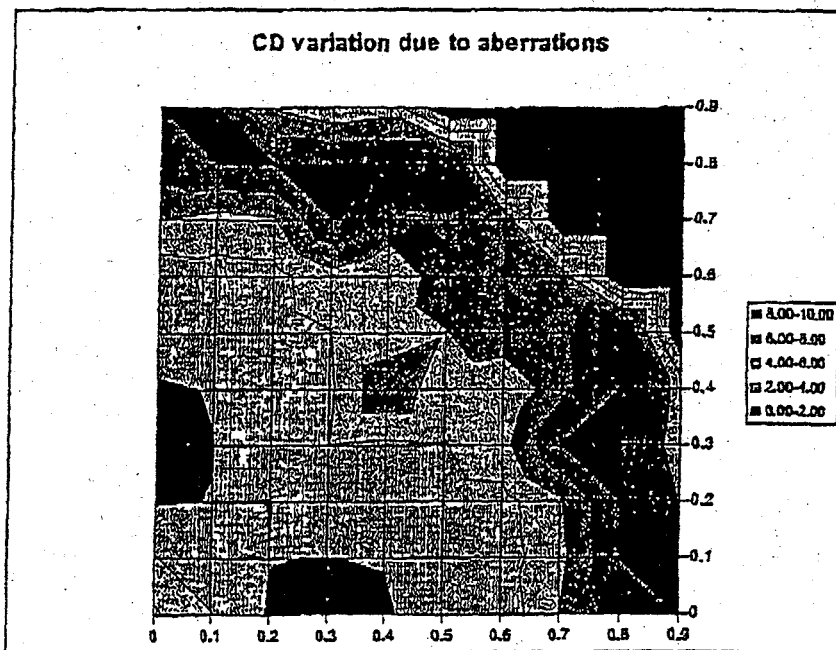

FIG. 42