



US008968847B2

(12) **United States Patent**
Weder

(10) **Patent No.:** **US 8,968,847 B2**
(45) **Date of Patent:** ***Mar. 3, 2015**

(54) **FLEXIBLE PACKAGING MATERIALS AND METHODS OF MAKING AND USING SAME**

B31D 5/0073 (2013.01); *B31D 5/0078* (2013.01); *B32B 1/02* (2013.01); *B32B 3/16* (2013.01); *B65B 55/20* (2013.01); (Continued)

(71) Applicant: **Wanda M. Weder and William F. Straeter, not individually but solely as Trustees of The Family Trust,** Highland, IL (US)

(58) **Field of Classification Search**
CPC B65D 81/052; B65D 23/02; B65D 81/03; B65D 81/00; B65D 81/02; B65D 9/10; B29D 22/02; B29D 22/00; B29D 23/00; B65B 23/00; B65B 23/02
USPC 428/34.1; 220/232; 206/457, 522; 217/122, 3 R; 53/472
See application file for complete search history.

(72) Inventor: **Donald E. Weder,** Highland, IL (US)

(73) Assignee: **Wanda M. Weder & William F. Straeter,** Highland, IL (US), not individually but solely as Trustees of The Family Trust U/T/A dated 12/8/1995

(*) Notice: Subject to any disclaimer, the term of this patent is extended or adjusted under 35 U.S.C. 154(b) by 0 days.
This patent is subject to a terminal disclaimer.

(56) **References Cited**

U.S. PATENT DOCUMENTS

524,219 A 8/1894 Schmidt
732,889 A 7/1903 Paver
(Continued)

(21) Appl. No.: **14/134,719**

FOREIGN PATENT DOCUMENTS

(22) Filed: **Dec. 19, 2013**

AU 4231978 6/1979
BE 654427 1/1965
(Continued)

(65) **Prior Publication Data**

US 2014/0103011 A1 Apr. 17, 2014

Related U.S. Application Data

(63) Continuation of application No. 13/692,169, filed on Dec. 3, 2012, now Pat. No. 8,728,596, which is a continuation of application No. 13/022,760, filed on Feb. 8, 2011, now abandoned, which is a continuation
(Continued)

Speed Cover Brochure, "The Simple Solution for Those Peak Volume Periods", Highland Supply Corporation, ©1989.
(Continued)

Primary Examiner — Michael C Miggins
(74) *Attorney, Agent, or Firm* — Dunlap Codding, P.C.

(51) **Int. Cl.**
B29D 22/00 (2006.01)
B29D 23/00 (2006.01)
(Continued)

(57) **ABSTRACT**
Packaging materials are disclosed, along with packages formed therefrom and methods for forming the packages.

(52) **U.S. Cl.**
CPC *B65D 9/10* (2013.01); *A41G 1/009* (2013.01);

14 Claims, 10 Drawing Sheets

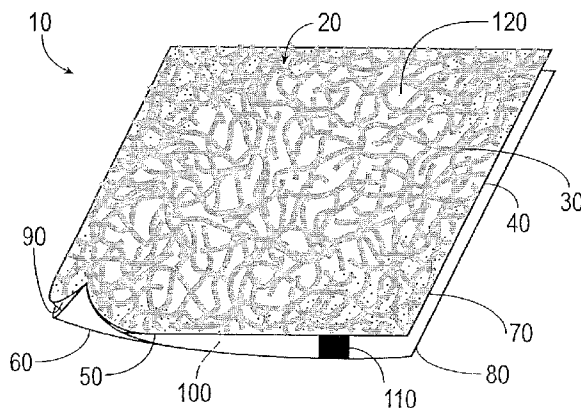

Related U.S. Application Data

of application No. 12/577,422, filed on Oct. 12, 2009, now Pat. No. 7,906,190, which is a continuation of application No. 11/063,024, filed on Feb. 22, 2005, now abandoned, which is a continuation-in-part of application No. 10/383,413, filed on Mar. 7, 2003, now abandoned, which is a continuation-in-part of application No. 09/934,301, filed on Aug. 21, 2001, now Pat. No. 6,534,136.

(51) **Int. Cl.**

- B32B 1/08** (2006.01)
- B31B 45/00** (2006.01)
- B65D 6/08** (2006.01)
- A41G 1/00** (2006.01)
- B31D 5/00** (2006.01)
- B32B 1/02** (2006.01)
- B32B 3/16** (2006.01)
- B65B 55/20** (2006.01)
- B65D 81/03** (2006.01)
- B65D 81/05** (2006.01)
- B65B 11/00** (2006.01)
- B65D 65/40** (2006.01)
- B65B 23/02** (2006.01)

(52) **U.S. Cl.**

- CPC **B65D 81/03** (2013.01); **B65D 81/05** (2013.01); **B65D 81/051** (2013.01); **B65D 81/052** (2013.01); **B65B 11/00** (2013.01); **B65D 65/406** (2013.01); **B65B 23/02** (2013.01); **B31D 2205/0023** (2013.01); **B31D 2205/0082** (2013.01)
- USPC **428/34.1**; 220/232; 206/457; 206/522; 217/122; 217/3 R; 53/472

(56)

References Cited

U.S. PATENT DOCUMENTS

950,785 A	3/1910	Pene
1,044,260 A	11/1912	Schloss
1,063,154 A	5/1913	Bergen
1,446,563 A	2/1923	Hughes
1,520,647 A	12/1924	Hennigan
1,525,015 A	2/1925	Weeks
1,610,652 A	12/1926	Bouchard
1,697,751 A	1/1929	Blake
1,794,212 A	1/1929	Snyder
1,811,574 A	3/1930	Barrett
1,863,216 A	6/1932	Wordingham
1,978,631 A	10/1934	Herrlinger
2,048,123 A	7/1936	Howard
RE21,065 E	5/1939	Copeman
2,170,147 A	8/1939	Lane
2,200,111 A	5/1940	Bensel
2,278,673 A	4/1942	Savada et al.
2,302,259 A	11/1942	Rothfuss
2,323,287 A	7/1943	Amborg
2,355,559 A	8/1944	Renner
2,371,985 A	3/1945	Freiberg
2,411,328 A	11/1946	MacNab
2,510,120 A	6/1950	Leander
2,529,060 A	11/1950	Trillich
2,621,142 A	12/1952	Wetherell
2,648,487 A	8/1953	Linda
2,688,354 A	9/1954	Berger
2,688,914 A	9/1954	Eckler
2,774,187 A	12/1956	Smithers
2,822,287 A	2/1958	Avery
2,846,060 A	8/1958	Yount
2,850,842 A	9/1958	Eubank, Jr.
2,883,262 A	4/1959	Borin

2,989,828 A	6/1961	Warp
3,003,681 A	10/1961	Orsini
3,022,605 A	2/1962	Reynolds
3,080,680 A	3/1963	Reynolds et al.
3,094,810 A	6/1963	Kalpin
3,121,647 A	2/1964	Harris et al.
3,130,113 A	4/1964	Silman
3,166,799 A	1/1965	Birnkrant
3,172,796 A	3/1965	Gülker
3,271,922 A	9/1966	Wallerstein et al.
3,293,100 A	12/1966	Questel
3,316,675 A	5/1967	Cartwright, Jr.
3,322,325 A	5/1967	Bush
3,357,152 A	12/1967	Geigel
3,376,666 A	4/1968	Leonard
3,380,646 A	4/1968	Doyen et al.
3,405,863 A	10/1968	Kugler
3,431,706 A	3/1969	Stuck
3,508,372 A	4/1970	Wallerstein et al.
3,510,054 A	5/1970	Sanni et al.
3,512,700 A	5/1970	Evans et al.
3,550,318 A	12/1970	Remke et al.
3,552,059 A	1/1971	Moore
3,554,434 A	1/1971	Anderson
3,556,389 A	1/1971	Gregoire
3,557,516 A	1/1971	Brandt
3,620,366 A	11/1971	Parkinson
3,681,105 A	8/1972	Milutin et al.
3,767,104 A	10/1973	Bachman et al.
3,793,799 A	2/1974	Howe et al.
3,804,322 A	4/1974	Ericson
3,869,828 A	3/1975	Matsumoto
3,888,443 A	6/1975	Flanigen
3,962,503 A	6/1976	Crawford
4,043,077 A	8/1977	Stonehocker
4,054,697 A	10/1977	Reed et al.
4,091,925 A	5/1978	Griffo et al.
4,113,100 A	9/1978	Soja et al.
4,118,890 A	10/1978	Shore
4,149,339 A	4/1979	Hall et al.
4,170,618 A	10/1979	Adams
4,189,868 A	2/1980	Tymchuck et al.
4,216,620 A	8/1980	Weder et al.
4,248,347 A	2/1981	Trimbee
D259,333 S	5/1981	Charbonneau
4,265,049 A	5/1981	Gorewitz
4,280,314 A	7/1981	Stuck
4,297,811 A	11/1981	Weder
4,333,267 A	6/1982	Witte
4,347,686 A	9/1982	Wood
4,380,564 A	4/1983	Cancio et al.
4,400,910 A	8/1983	Koudstall et al.
4,413,725 A	11/1983	Bruno et al.
4,508,223 A	4/1985	Catrambone
D279,279 S	6/1985	Wagner
4,546,875 A	10/1985	Zweber
4,621,733 A	11/1986	Harris
4,640,079 A	2/1987	Stuck
4,674,972 A	6/1987	Wagner
4,692,111 A	9/1987	Wagner
4,717,262 A	1/1988	Roen et al.
4,733,521 A	3/1988	Weder et al.
4,765,464 A	8/1988	Ristvedt
4,771,573 A	9/1988	Stengel
4,773,182 A	9/1988	Weder et al.
4,801,014 A	1/1989	Meadows
4,810,109 A	3/1989	Castel
4,835,834 A	6/1989	Weder
D301,991 S	7/1989	Van Sant
D304,317 S	10/1989	Wagner
4,900,390 A	2/1990	Colten et al.
4,941,572 A	7/1990	Harris
4,946,290 A	8/1990	Matyja
4,980,209 A	12/1990	Hill
4,989,396 A	2/1991	Weder et al.
D315,700 S	3/1991	Stephens
5,073,161 A	12/1991	Weder et al.
5,074,675 A	12/1991	Osgood
5,076,011 A	12/1991	Stehouwer

(56)

References Cited

U.S. PATENT DOCUMENTS

5,102,034 A 4/1992 Amabili
 5,105,599 A 4/1992 Weder
 5,111,638 A 5/1992 Weder
 5,117,584 A 6/1992 Ottenwalder
 5,120,382 A 6/1992 Weder
 5,152,100 A 10/1992 Weder et al.
 5,181,364 A 1/1993 Weder
 D335,105 S 4/1993 Ottenwalder et al.
 5,199,242 A 4/1993 Weder et al.
 5,205,108 A 4/1993 Weder et al.
 5,228,234 A 7/1993 de Klerk et al.
 5,235,782 A 8/1993 Landau
 5,239,775 A 8/1993 Landau
 5,249,407 A 10/1993 Stuck
 5,259,106 A 11/1993 Weder et al.
 5,307,606 A 5/1994 Weder
 5,315,785 A 5/1994 Avôt et al.
 5,350,240 A 9/1994 Billman et al.
 5,353,575 A 10/1994 Stepanek
 5,361,482 A 11/1994 Weder et al.
 5,388,695 A 2/1995 Gilbert
 5,428,939 A 7/1995 Weder et al.
 5,443,670 A 8/1995 Landau
 D362,829 S 10/1995 Wagner
 5,493,809 A 2/1996 Weder et al.
 D368,025 S 3/1996 Sekerak et al.
 5,496,251 A 3/1996 Cheng
 5,496,252 A 3/1996 Gilbert
 5,526,932 A 6/1996 Weder
 5,551,570 A 9/1996 Shaffer et al.
 5,572,849 A 11/1996 Weder et al.
 5,572,851 A 11/1996 Weder
 5,575,107 A 11/1996 Doerr
 5,575,133 A 11/1996 Weder et al.
 5,617,703 A 4/1997 Weder
 5,624,320 A 4/1997 Martinez
 5,625,979 A 5/1997 Weder
 5,647,168 A 7/1997 Gilbert
 5,647,193 A 7/1997 Weder et al.
 5,706,605 A 1/1998 Alzacar
 5,715,944 A 2/1998 Windisch
 5,735,103 A 4/1998 Weder
 5,758,472 A 6/1998 Weder
 5,813,194 A 9/1998 Weder
 D399,787 S 10/1998 Wagner
 D399,788 S 10/1998 Wagner
 5,823,840 A 10/1998 Powers
 D404,684 S 1/1999 Shea
 5,891,286 A 4/1999 Weder
 D409,057 S 5/1999 Wagner
 5,924,241 A 7/1999 Hodge
 5,941,020 A 8/1999 Weder
 D413,547 S 9/1999 Wagner
 5,966,866 A 10/1999 Ferguson
 5,974,730 A 11/1999 Chien
 5,985,380 A 11/1999 Weder
 5,992,637 A 11/1999 Weder
 D419,436 S 1/2000 Celtorius et al.
 6,009,687 A 1/2000 Weder
 6,047,524 A 4/2000 Weder
 D424,972 S 5/2000 Ferguson
 6,065,601 A 5/2000 Weder
 6,071,445 A 6/2000 Wagner
 D428,827 S 8/2000 Wagner
 6,098,336 A 8/2000 Ferguson
 D431,495 S 10/2000 Wagner
 6,129,208 A 10/2000 Ferguson
 6,129,209 A 10/2000 Tchira
 6,141,906 A 11/2000 Weder
 D435,481 S 12/2000 Wagner
 6,182,395 B1 2/2001 Weder
 6,183,590 B1 2/2001 Weder
 D448,130 S 9/2001 Wagner
 6,286,255 B1 9/2001 Weder et al.
 6,286,256 B1 9/2001 Weder

6,345,467 B1 2/2002 Weder
 6,534,136 B2 3/2003 Weder
 6,740,274 B2* 5/2004 Weder et al. 264/132
 7,906,190 B2 3/2011 Weder
 2002/0078506 A1 6/2002 Slood
 2002/0112401 A1 8/2002 Weder et al.

FOREIGN PATENT DOCUMENTS

CH 560532 4/1975
 DE 15550 6/1900
 DE 345464 12/1921
 DE 513971 11/1930
 DE 1166692 3/1964
 DE 1962947 6/1971
 DE 2060812 11/1971
 DE 2748626 5/1979
 DE 3445799 6/1986
 DE 3911847 10/1990
 DK 1204647 9/1970
 EP 0050990 5/1982
 EP 0791543 8/1997
 FR 1376047 9/1964
 FR 2036163 12/1970
 FR 2137325 12/1972
 FR 2272914 12/1975
 FR 2332144 7/1977
 FR 2489126 3/1982
 FR 2567068 7/1984
 FR 2610604 8/1988
 FR 2603159 3/1989
 FR 2619698 3/1989
 GB 5605 0/1885
 GB 2056410 3/1981
 GB 2074542 11/1981
 GB 2100357 12/1982
 GB 2128083 4/1984
 GB 2203127 10/1988
 GB 2212136 7/1989
 GB 2252708 8/1992
 IT 224507 4/1996
 JP 542958 2/1993
 JP 6127555 5/1994
 JP 8-19334 1/1996
 NL 8301709 12/1984
 NL 1000658 1/1996
 WO 9315979 8/1993
 WO 9712819 4/1997

OTHER PUBLICATIONS

“Speed Sheets and Speed Rolls” Brochure, Highland Supply Corporation, ©1990.
 “Color Them Happy with Highlander Products” ©1992.
 “Costa Keeps the Christmas Spirit”, Supermarket Floral, Sep. 15, 1992.
 “Super Seller”, Supermarket Floral, Sep. 15, 1992.
 “Halloween”, Link Magazine, Sep. 1992.
 “Now More Than Ever”, Supermarket Floral, Sep. 15, 1992.
 Le Plant Sac Advertisement, published prior to Sep. 26, 1987.
 “A World of Cut Flower and Pot Plant Packaging” Brochure, Klerk’s Plastic Products Manufacturing, Inc., published prior to Mar. 31, 1994, 6 pages.
 Chantler & Chantler brochure showing Zipper Sleeve™ and Florasheet®, published prior to Mar. 31, 1994, 2 pages.
 “Stand Alone Plastic Bagmaking” brochure, AMI, Atlanta, GA, Feb. 15, 1996, 2 pages.
 “Foil Jackets” brochure, Custom Medallion, Inc., Dec. 1996, 2 pages.
 “Derwent Abstract” of FR 2610604A. It is noted that the abstract is an incorrect English translation of the contents of the French patent. The French patent does not enable or disclose adhesively attaching the covering to the container. 1988.
 “Silver Linings” Brochure, Affinity Diversified Industries, Inc., 1986. The Silver Linings brochure shows a floral sleeve with a closed bottom. The brochure shows, in one embodiment, a vase with flowers inside a “cut flower” sleeve with the sleeve tied with a ribbon about the neck of the vase.

(56)

References Cited

OTHER PUBLICATIONS

“Special Occasion Printed Highlophane Bags” Brochure, Highland Supply Corporation, 1990, 2 pages.

“Creative Packaging” Brochure, John Henry Company, Sep. 1992.

“Make Highlander Your Headquarters” Brochure, Highland Supply Corporation, 1991.

U.S. Appl. No. 10/383,413, filed Mar. 7, 2003; Office Action, dated Aug. 25, 2004.

U.S. Appl. No. 10/383,413, filed Mar. 7, 2003; Office Action, dated Jun. 8, 2005.

U.S. Appl. No. 10/383,413, filed Mar. 7, 2003; Office Action, dated Apr. 14, 2006.

U.S. Appl. No. 10/383,413, filed Mar. 7, 2003; Office Action, dated Oct. 12, 2006.

U.S. Appl. No. 10/383,413, filed Mar. 7, 2003; Office Action, dated Jun. 26, 2007.

U.S. Appl. No. 10/383,413, filed Mar. 7, 2003; Final Office Action, dated Mar. 31, 2008.

U.S. Appl. No. 11/063,024, filed Feb. 22, 2005; Office Action, dated Jan. 9, 2008.

U.S. Appl. No. 11/063,024, filed Feb. 22, 2005; Office Action, dated Oct. 6, 2008.

U.S. Appl. No. 11/063,024, filed Feb. 22, 2005; Final Office Action, dated Jul. 10, 2009.

U.S. Appl. No. 12/577,422, filed Oct. 12, 2009; Office Action, dated Apr. 29, 2010.

U.S. Appl. No. 12/577,422, filed Oct. 12, 2009; Notice of Allowance, dated Nov. 15, 2010.

U.S. Appl. No. 11/283,008, filed Nov. 18, 2005; Office Action, dated Mar. 25, 2008.

U.S. Appl. No. 11/283,008, filed Nov. 18, 2005; Office Action, dated Dec. 1, 2008.

U.S. Appl. No. 11/283,008, filed Nov. 18, 2005; Final Office Action, dated Aug. 18, 2009.

U.S. Appl. No. 12/634,086, filed Dec. 9, 2009; Office Action, dated Jul. 21, 2010.

U.S. Appl. No. 13/011,325, filed Jan. 21, 2011; Office Action, dated Dec. 8, 2011.

U.S. Appl. No. 13/011,325, filed Jan. 21, 2011; Final Office Action, dated Jul. 5, 2012.

U.S. Appl. No. 13/022,760, filed Feb. 8, 2011; Office Action, dated Jan. 19, 2012.

U.S. Appl. No. 13/022,760, filed Feb. 8, 2011; Office Action, dated May 23, 2012.

* cited by examiner

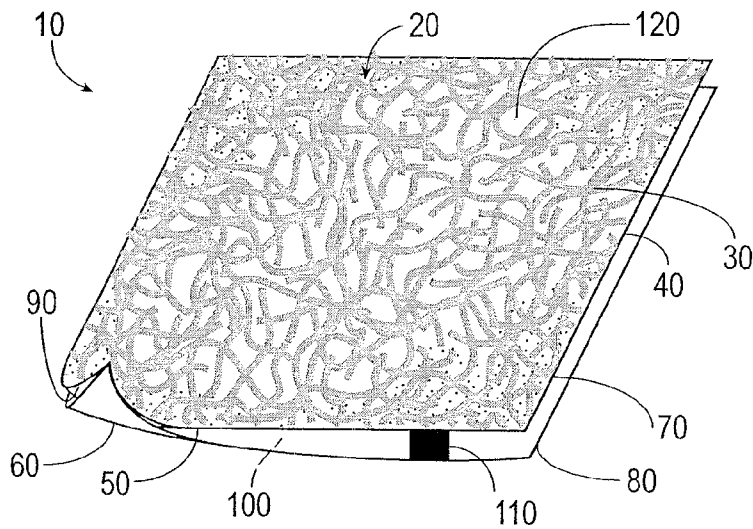

Fig. 1

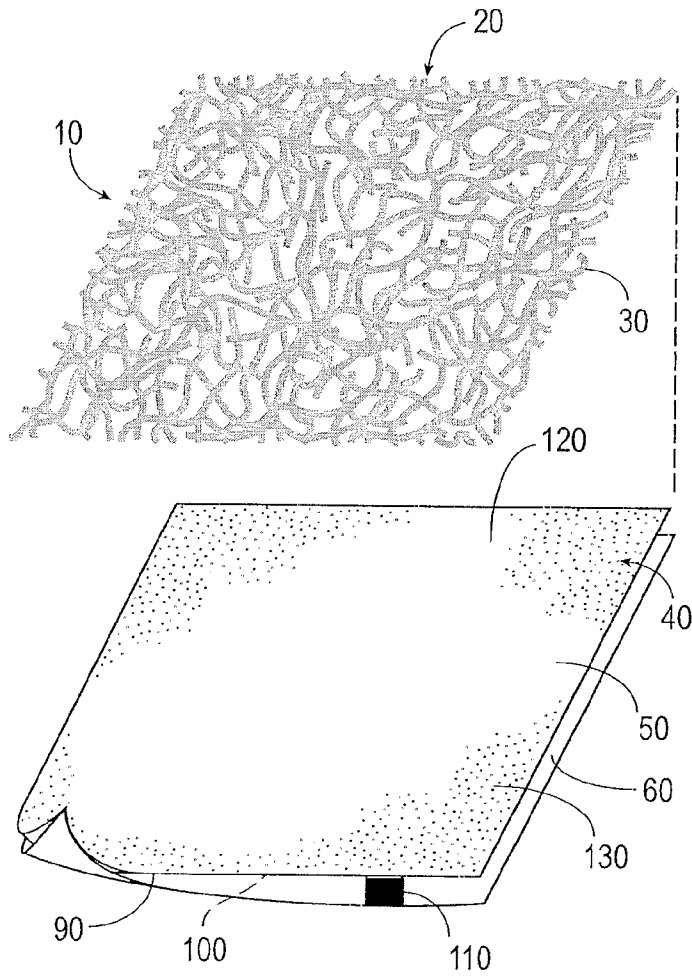

Fig. 2

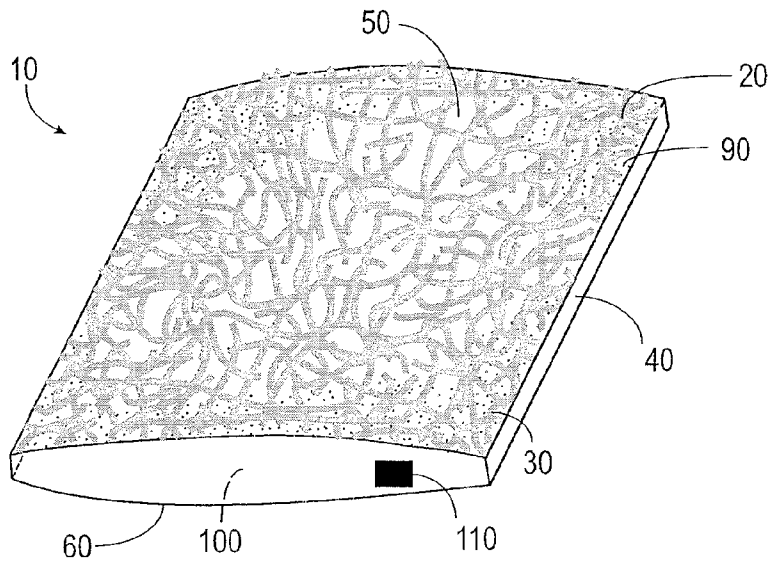

Fig. 2A

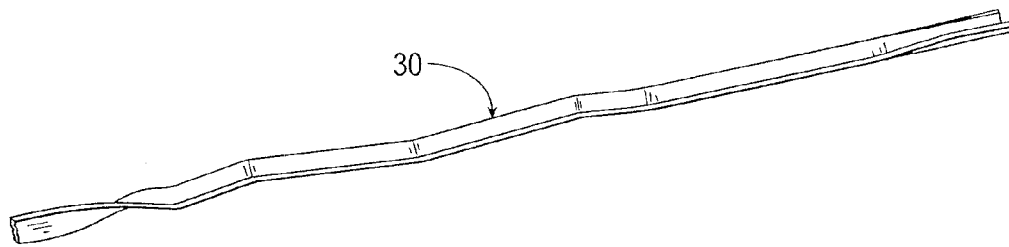

Fig. 3

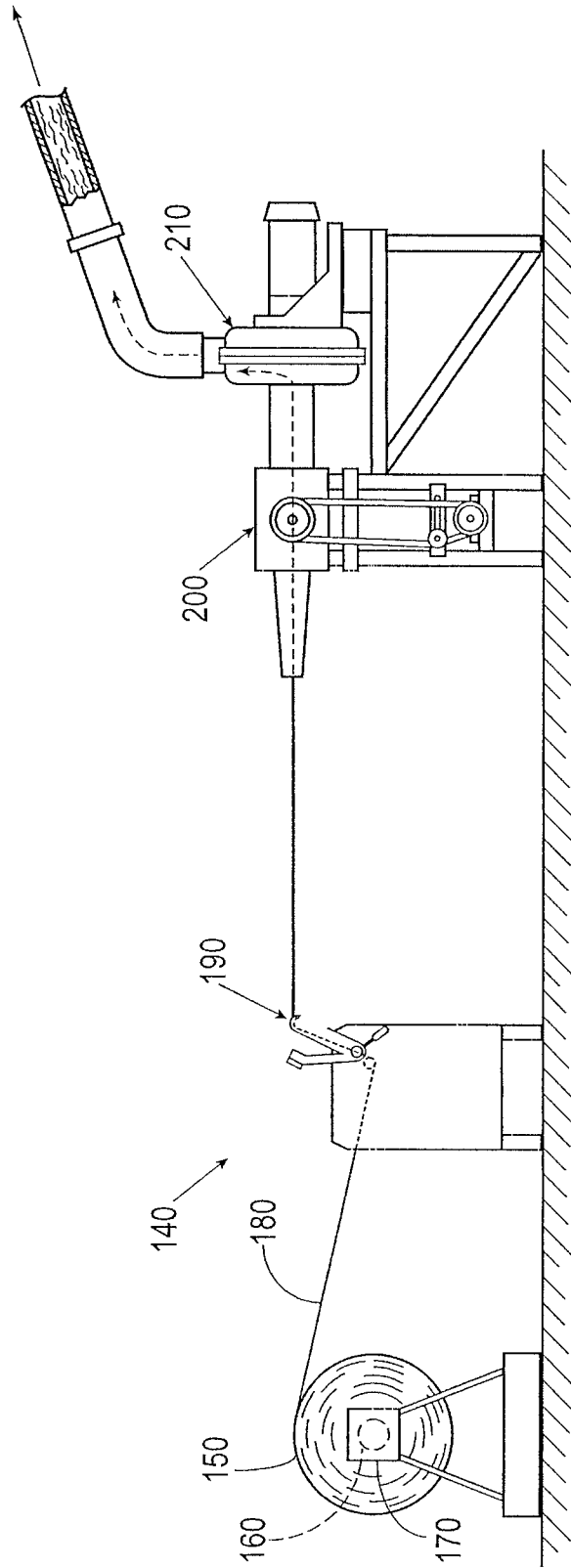

Fig. 4

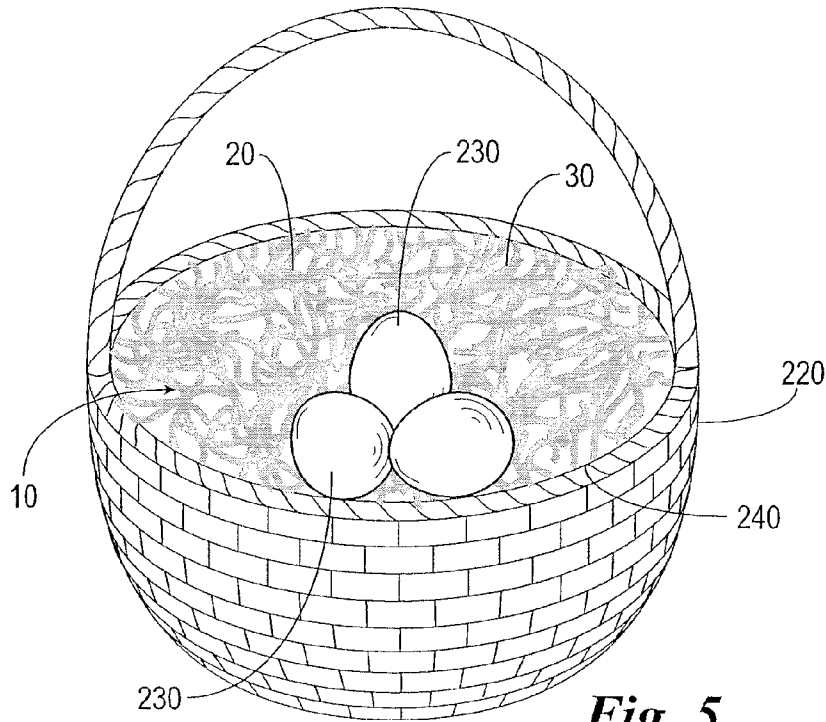

Fig. 5

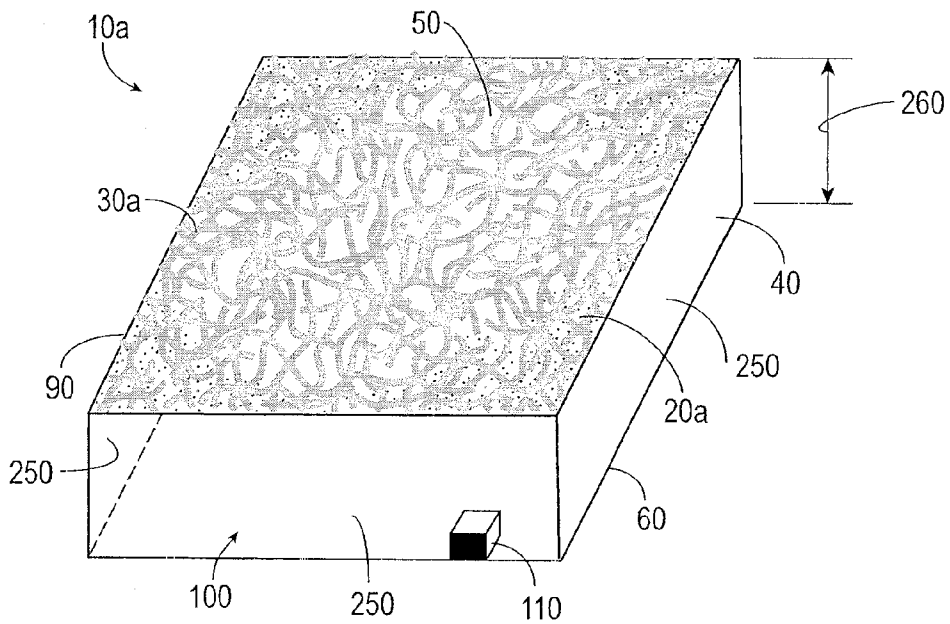
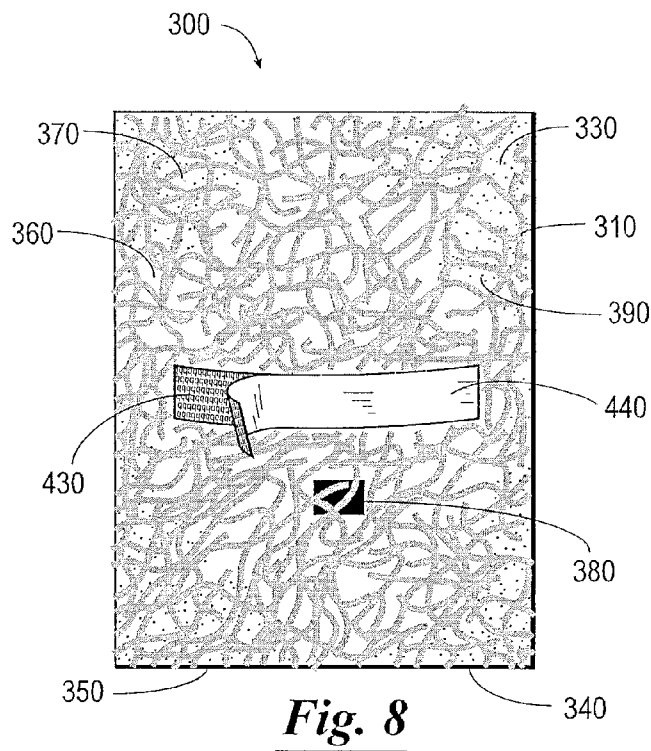
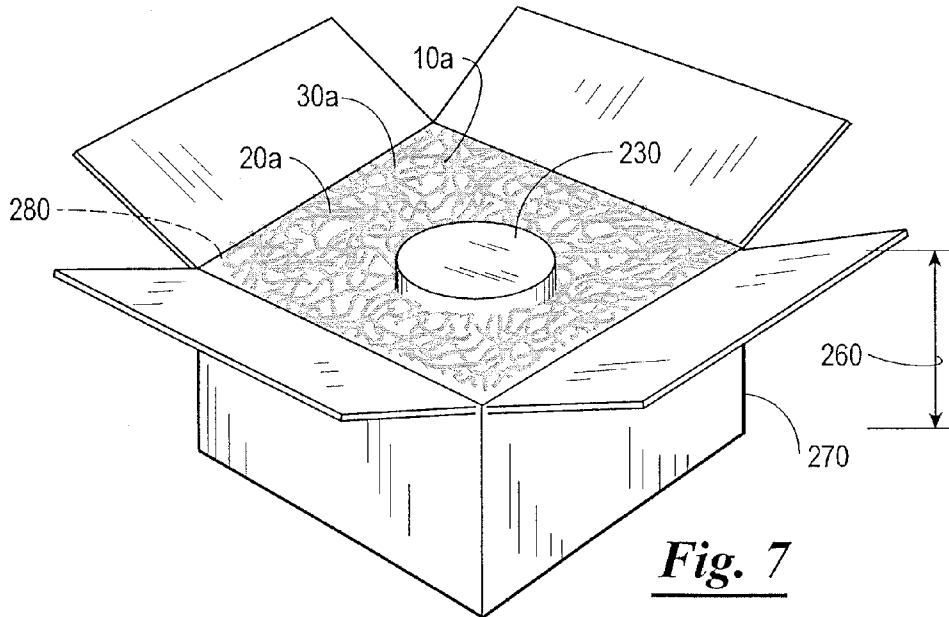
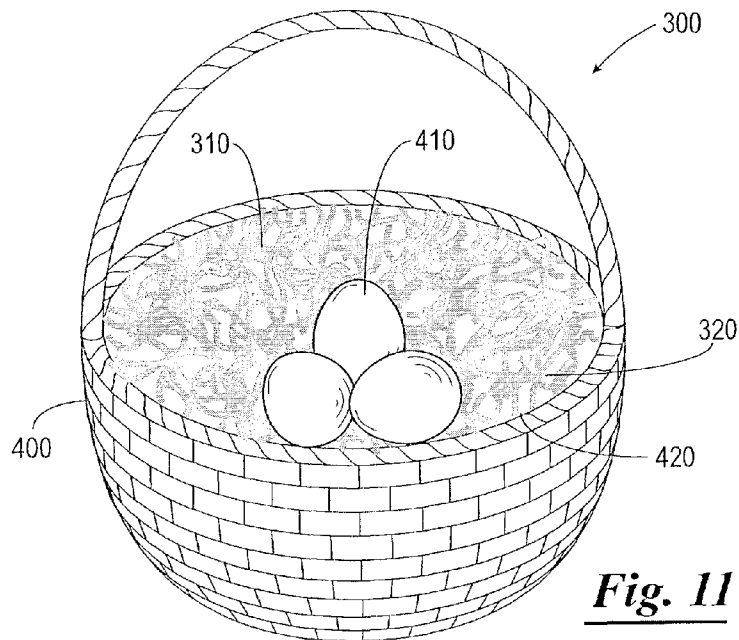
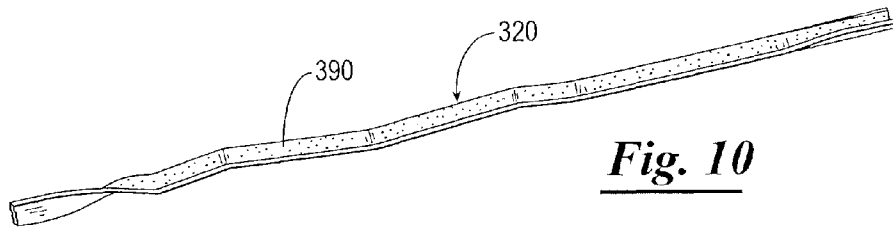
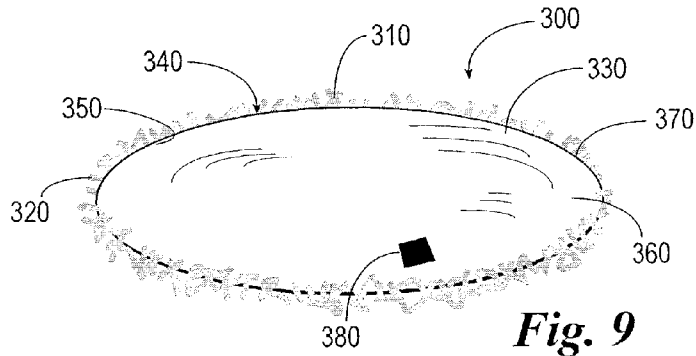

Fig. 6





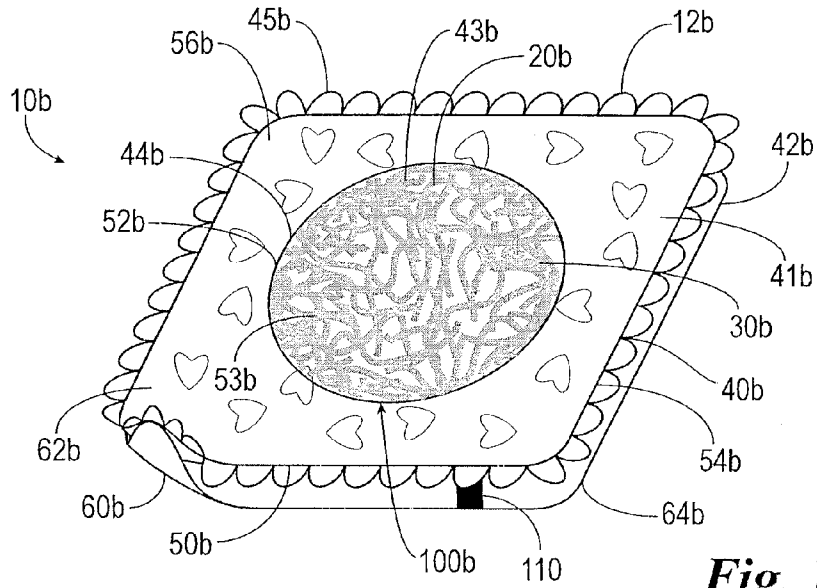

Fig. 12

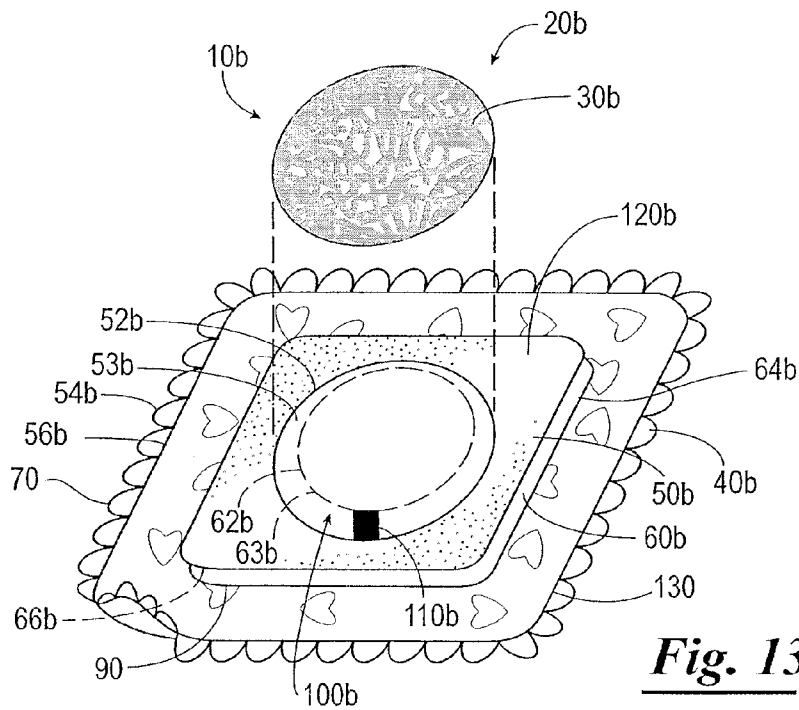

Fig. 13

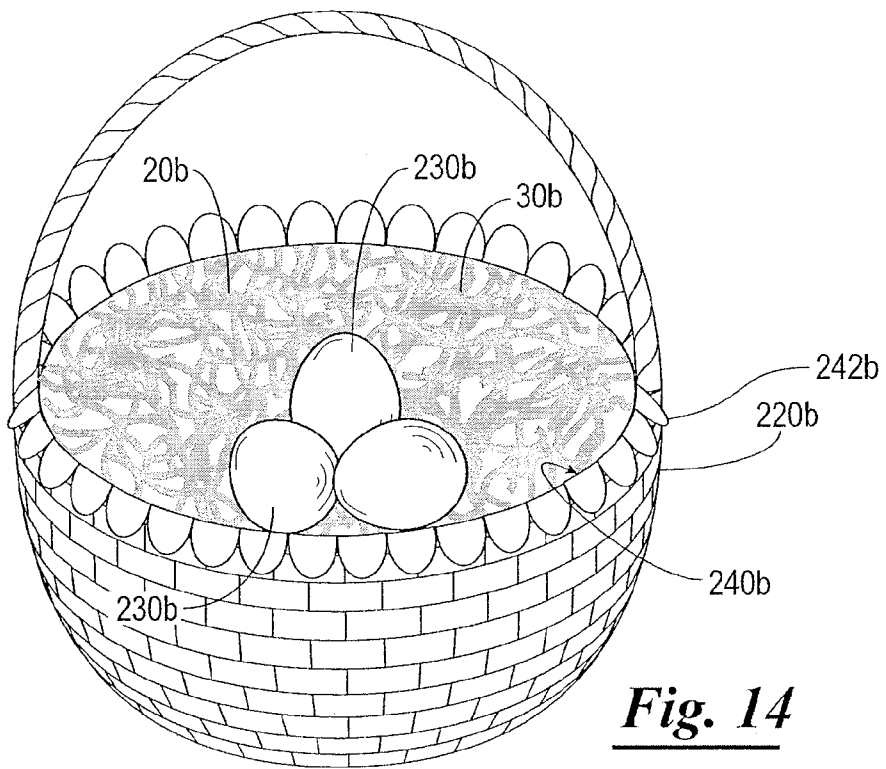

Fig. 14

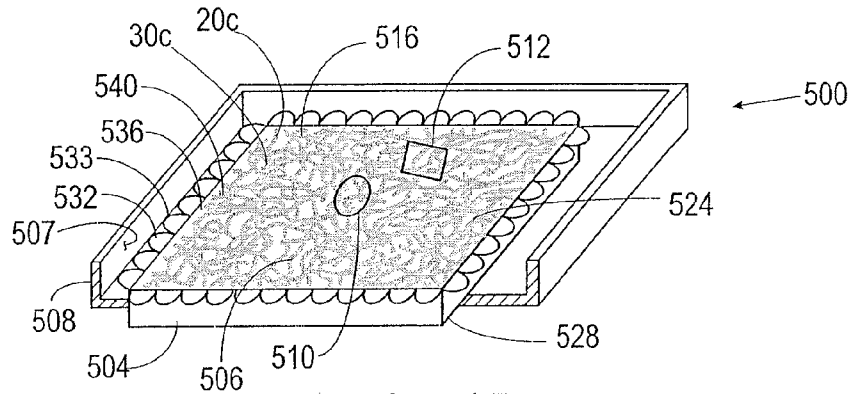

Fig. 15

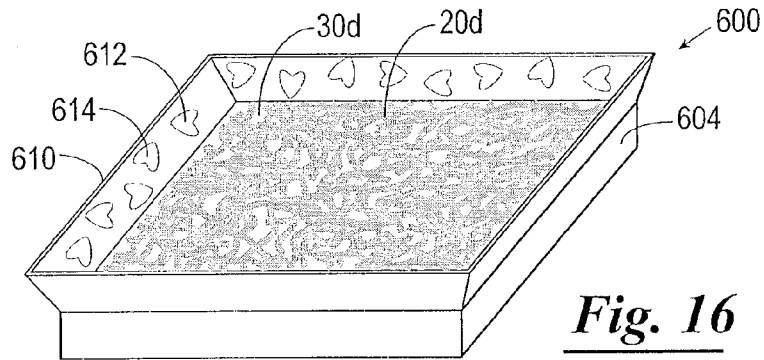

Fig. 16

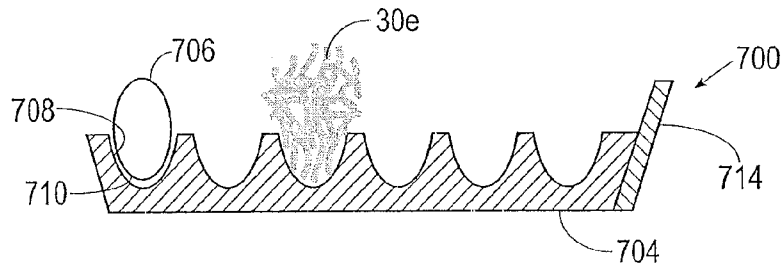

Fig. 17

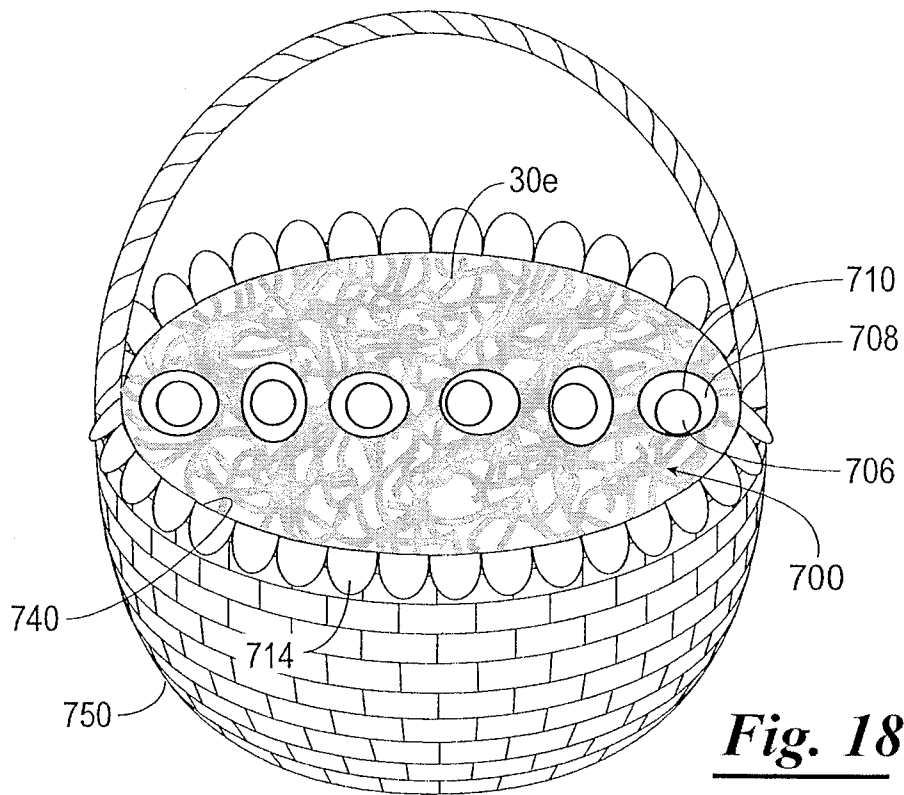

Fig. 18

FLEXIBLE PACKAGING MATERIALS AND METHODS OF MAKING AND USING SAME

CROSS REFERENCE TO RELATED APPLICATIONS/INCORPORATION BY REFERENCE STATEMENT

This application is a continuation of U.S. Ser. No. 13/692, 169, filed Dec. 3, 2012; which is a continuation of U.S. Ser. No. 13/022,760, filed Feb. 8, 2011, now abandoned; which is a continuation of U.S. Ser. No. 12/577,422, filed Oct. 12, 2009, now U.S. Pat. No. 7,906,190, issued Mar. 15, 2011; which is a continuation of U.S. Ser. No. 11/063,024, filed Feb. 22, 2005, now abandoned; which is a continuation-in-part of U.S. Ser. No. 10/383,413, filed on Mar. 7, 2003, now abandoned; which is a continuation-in-part of U.S. Ser. No. 09/934,301, filed Aug. 21, 2001, now U.S. Pat. No. 6,534, 136. The entire contents of each of the above-referenced patents and patent applications are expressly incorporated herein by reference.

BACKGROUND

In the process of shipping an article from one location to another, the article is typically placed in a container along with a protective packaging material to fill the voids about the article and to cushion the article during the shipping process. One common protective packaging material includes a plurality of plastic foam, peanut-shaped members which are commonly known as "Styrofoam peanuts". An advantage in using Styrofoam peanuts is the ease with which they may be disposed about an article positioned in a container by simply pouring the Styrofoam peanuts from a dispenser.

While Styrofoam peanuts have been widely accepted in the packaging industry, they are not without disadvantages. For example, their light weight and flowability results in heavier objects gravitating through the peanuts to the bottom of the container where the heavier objects can be damaged. Also, while the flowability of the Styrofoam peanuts facilitates the introduction of the peanuts into a container, the receiver of the package is left with having to deal with cleaning up the mess left by the peanuts which are easily scattered upon removal of the article from the container.

These and other disadvantages associated with the disposal of Styrofoam peanuts, have made paper protective packaging material a popular alternative. Paper is biodegradable, recyclable, and renewable therefore making it an environmentally responsible choice. However, like Styrofoam peanuts, paper packaging materials are not without disadvantages. Paper, particularly shredded paper, can be inconvenient to clean up and to dispose of due to the lack of cohesiveness of the packaging material. Due to the lack of resiliency in paper products, large amounts of paper are typically required to provide the bulk needed to adequately cushion an object.

Strips of sheet material formed into tufts have also been used for many years as a packaging material. More specifically, material known as decorative grass has been used in fruit baskets, Easter baskets, picnic baskets, and for other packaging and decorative purposes. The decorative grass of the prior art has been produced by numerous methods and from a variety of materials such as polymeric materials, paper, cellophane or the like. Typically, such materials are cut and shredded to produce segments having predetermined dimensions. As such, decorative grass, like Styrofoam peanuts and paper materials described above, can be inconvenient to clean up. Furthermore, the decorative grass can compress and lose its cushioning ability. Large amounts of

decorative grass are necessary, therefore, in order to overcome such compression and/or compaction deficiencies.

To this end, a packaging material is needed that includes or mimics a plurality of resilient individual strips, strands, or units of material intertwined with one another or other organic or inorganic materials that may be bondably connected to a flexible substrate or substratum so as to form a unitary cushioning unit which overcomes the above-mentioned disadvantages of prior art packaging materials and has the added benefit of providing a decorative border. It is to such a packaging material that the presently disclosed and claimed inventive concept(s) is directed.

BRIEF DESCRIPTION OF THE DRAWINGS

FIG. 1 is a perspective view of an inflatable packaging material (in a deflated condition) constructed in accordance with the presently disclosed and claimed inventive concept(s), one edge of the uninflatable packaging material being upwardly turned for illustration purposed only.

FIG. 2 is an exploded view of the inflatable packaging material of FIG. 1.

FIG. 2A is a perspective view of the inflatable packaging material of FIG. 1 in an inflated condition.

FIG. 3 is a perspective view of a strip, strand, or unit of material used to form a tuft of the inflatable packaging material constructed in accordance with the presently disclosed and claimed inventive concept(s).

FIG. 4 is a schematic representation of a system for making the strip, strand, or unit of material of FIG. 3.

FIG. 5 is a perspective view of a basket having the inflatable packaging material disposed therein with a plurality of eggs displayed or cushioned thereon.

FIG. 6 is a perspective view of another embodiment of the inflatable packaging material in an inflated condition constructed in accordance with the presently disclosed and claimed inventive concept(s).

FIG. 7 is a perspective view of a package illustrating the inflatable packaging material of FIG. 6 disposed therein for cushioning an article during a shipping process.

FIG. 8 is an elevational view of another embodiment of a packaging material constructed in accordance with the presently disclosed and claimed inventive concept(s).

FIG. 9 is a perspective view of the inflatable packaging material of FIG. 8.

FIG. 10 is a perspective view of a strip, strand, or unit of material used to form a tuft of the inflatable packaging material of the presently disclosed and claimed inventive concept(s).

FIG. 11 is a perspective view of a basket showing the inflatable packaging material of FIG. 9 inserted therein and supporting and cushioning eggs.

FIG. 12 is a perspective view of another embodiment of an inflatable packaging material constructed in accordance with the presently disclosed and claimed inventive concept(s).

FIG. 13 is an exploded view of the inflatable packaging material of FIG. 12.

FIG. 14 is a perspective view of a basket having the inflatable packaging material of FIG. 12 disposed therein with a plurality of eggs displayed or cushioned thereon.

FIG. 15 is a cut away view of a container having a packaging material constructed in accordance with the presently disclosed and claimed inventive concept(s) disposed therein.

FIG. 16 is a perspective view of another embodiment of a packaging material constructed in accordance with the presently disclosed and claimed inventive concept(s).

FIG. 17 is a cross-sectional view of the packaging material of FIG. 16 having a plurality of eggs displayed thereon.

FIG. 18 is a perspective view of a basket having the packaging material of FIG. 17 disposed therein with a plurality of eggs cushioned or displayed thereon.

DETAILED DESCRIPTION

Before explaining the various embodiments of the presently disclosed and claimed inventive concept(s) in detail, it is to be understood that the presently disclosed and claimed inventive concept(s) is not limited in its application to the details of construction and the arrangement of the components set forth in the following description or illustrated in the drawings. The presently disclosed and claimed inventive concept(s) is capable of other embodiments or of being practiced or carried out in various ways and as such all such embodiments and/or equivalents are to be considered as being encompassed within the scope and description of the presently disclosed and claimed inventive concept(s). Also, it is to be understood that the phraseology and terminology employed herein is for purpose of description and should not be regarded as limiting.

The presently disclosed and claimed inventive concept(s) relates, generally, to packaging material for use in filling boxes, baskets, and in any container used to protect, store, and/or ship articles or objects. In one embodiment, the packaging material includes an inflatable flexible substrate having a decorative border and a mass of individual, thin, flexible strips, strands, or units of material intertwined with one another to form a cohesive, resilient tuft. The mass of individual strips, strands, or units of material may also be attached to one another as well as being disposed on the exterior surface of the inflatable flexible substrate. In an alternate embodiment the inflatable flexible substrate is exchanged or replaced by a cushioning substratum.

The packaging material formed according to the methods disclosed herein may be incorporated into a package which additionally includes a container, such as a box or basket, and an object positioned within the container and on top of the packaging material. The packaging material is arranged in the container to support the object when the object is disposed in the container. The packaging material may be caused to bond to the container and the object may be caused to bond to the packaging material. In use, the packaging material is disposed so as to take up excess room in the container and protect and/or cushion the object.

The objects, features and advantages of the presently disclosed and claimed inventive concept(s) will become apparent from the following detailed description when read in conjunction with the accompanying drawings and appended claims.

Referring now to the drawings, and more specifically to FIGS. 1-3, an inflatable packaging material 10 constructed in accordance with the presently disclosed and claimed inventive concept(s) is illustrated in FIG. 1. The inflatable packaging material 10 includes a tuft 20 comprised of a plurality of individual strips, strands, or units of material 30 (FIG. 3) bondably connected to a flexible inflatable substrate 40.

The plurality of individual strips, strands, or units of material 30 can be fabricated from any flexible sheet of material including but not limited to: paper, crepe paper, polymeric film, laminated polymeric film, and waxed paper, for example. In one embodiment of the presently disclosed and claimed inventive concept(s) the laminated polymeric film for example but not by way of limitation can be at least one clear layer of polymeric film laminated to at least one iridescent

layer of polymeric film so as to provide an iridescent effect to the laminated polymeric film. The flexible sheet of material from which the plurality of individual strips, strands, or units of material 30 are fabricated may have printed matter and/or one or more embossed patterns on at least one side thereof, and the one or more embossed patterns may be either in register or out of register with the printed pattern.

The plurality of individual strips, strands, or units of material 30 may also be organic or inorganic materials, including leaves, tree bark, branches, dirt, sand, sea shells, or any other type of organic or inorganic material that is capable of being bondably connected to the flexible inflatable substrate 40 to provide a decorative and/or cushioning effect. Furthermore, when the plurality of individual strips, strands, or units of material 30 are fabricated from a flexible sheet of material, additional inorganic and/or organic materials may be attached onto or be incorporated into or within the flexible sheet of material prior to or after its being used to fabricate the plurality of individual strips, strands, or units of material 30.

The printed pattern on the flexible sheet of material from which the plurality of individual strips, strands, or units of material 30 are fabricated can be printed in a conventional matter so that, when the sheet of material is slit and cut to produce the strips, strands, or units of material 30, at least a substantial portion of the strips, strands, or units of material 30 contain at least a portion of the printed pattern. Further, different colors can be employed to provide the printed pattern on the sheet of material from which the plurality of individual strips, strands, or units of material 30 is fabricated.

The sheet of material can also have one or more embossed patterns to provide the sheet of material with an embossed pattern. Further, the sheet of material can be provided with an embossed pattern as well as a printed pattern, and the embossed pattern can be either in register or out of register with the printed material and/or printed design.

The plurality of individual strips, strands, or units of material 30, as described above, in one embodiment are commonly referred to as strands, or units of "Easter grass" or "decorative grass", and such, decorative grass has been used for many years for filling fruit baskets, Easter baskets, and picnic baskets and for other decorative and packaging purposes. The decorative grass of the prior art has been produced by numerous methods and from a variety of materials, such as those listed above. Typically, such materials are shredded and cut to produce segmented strips having predetermined dimensions. While the prior art methods for making decorative grass have been widely accepted, new techniques for facilitating the use of decorative grass as a packaging material have been sought in view of the fact that decorative grass and other loose shredded packaging material readily fall onto the floor, cling to various objects making them awkward and inconvenient to clean up, and compact and thereby no longer adequately cushion and/or protect the items placed thereon.

By connecting the tuft 20 (composed of a plurality of the strips, strands, or units of material 30) to the flexible inflatable substrate 40, the clean up problems associated with loose fill materials are alleviated and, because the flexible inflatable substrate 40 is capable of being inflated, the compacting problems with loose fill are also alleviated and lesser amounts of material are required. The flexible inflatable substrate 40 can also be caused to adhere or cohere to an object and/or the container in which it is placed thereby resulting in an enhanced packaging effect. That is, with loose packaging materials, the object being packaged has a tendency to gravitate through the packaging material to the bottom of the container thereby reducing the effectiveness of the packaging material. By using the inflatable packaging material 10 dis-

closed herein, the cohesiveness of the inflatable packaging material **10** surrounding the object prevents the object from gravitating through the container and coming to rest in the bottom of the container.

As best shown in FIG. 2, the flexible inflatable substrate **40**, in one embodiment, is fabricated of a first sheet of material **50** and a second sheet of material **60**. It will be appreciated that the dimensions of the flexible inflatable substrate **40** may be further varied and the shape of the flexible inflatable substrate **40** may also, therefore, be variable—e.g., a circle, square, triangle, heart, an animal shape, a floral shape, etc. The flexible inflatable substrate **40** can be any flexible sheet of material, such as paper, crepe paper, wax paper, polymeric film, laminated polymeric film, fabric, cellulose, and foil. The flexible inflatable substrate **40** may have printed matter and/or one or more embossed patterns on at least one side thereof, and the one or more embossed patterns can be either in register or out of register with the printed pattern. Different colors can be employed to provide the printed pattern on the flexible inflatable substrate **40**. For example, the printed pattern may be a pictorial representation or color or shape of the plurality of individual strips, strands, or units of material **30** such that when a small amount of the plurality of individual strips, strands, or units of material **30**, forming the tuft **20** are bonded to the flexible inflatable substrate **40**, the printed pattern fills in the voids between the plurality of individual strips, strands, or units of material **30** such that it appears that there are few or no actual voids of the plurality of individual strips, strands, or units of material **30** on the flexible inflatable substrate **40** thereby resulting in an aesthetically pleasing inflatable packaging material **10** that appears to be fully covered with the individual strips, strands, or units of material **30**.

The first sheet of material **50** and the second sheet of material **60** of the flexible inflatable substrate **40** may be constructed of a single layer of material or a plurality of layers of the same or different types of materials. In addition, any thickness of the first sheet of material **50** and the second sheet of material **60** of the flexible inflatable substrate **40** may be utilized with the presently disclosed and claimed inventive concept(s). The first sheet of material **50** has an outer peripheral edge **70** and the second sheet of material **60** has an outer peripheral edge **80**. The outer peripheral edge **70** of the first sheet of material **50** is bonded via a bonding material **90** to the outer peripheral edge **80** of the second sheet of material **60** to provide and define an expandable interior inflation space **100**. A means **110** for inflating the flexible inflatable substrate **40** is placed within the expandable interior inflation space **100**.

The means **110** for inflating the flexible inflatable substrate **40** may be any composition or assembly capable of inflating the expandable interior inflation space **100** to provide and place the inflatable packaging material **10** in its inflated configuration. For example, the means **110** for inflating the flexible inflatable substrate **40** may be associated with an exterior surface **120** of the flexible inflatable substrate **40** and be in fluid communication with the expandable interior inflation space **100**—e.g., a tube capable of being sealed off after air and/or other gases and/or liquids are passed into the expandable interior inflation space **100**.

In an alternative embodiment the means **110** for inflating the expandable interior inflation space **100** is an exothermic reaction assembly wherein, when the exothermic reaction assembly is activated, an exothermic reaction takes place thereby producing a gas capable of filling at least a portion of the expandable interior inflation space **100** of the flexible inflatable substrate **40**. The exothermic reaction assembly may further include at least two chambers wherein at least one other chamber contains a weak basic composition and at least

one chamber contains a weak acid composition that, when brought into reactive contact with one another (e.g., breaking each open to intermix the weak acid composition with the weak basic composition), react and form a gaseous reaction product that substantially fills the expandable interior inflation space **100** of the flexible inflatable substrate **40**. The weak basic composition may in one embodiment include a Group I or Group II element. For example, the weak basic composition may be selected from the group consisting of sodium carbonate, calcium carbonate, and combinations thereof. The weak acid may be vinegar. Although certain compositions have been set forth as being included in the exothermic reaction assembly, any combination of compositions that, when placed in reactive contact with one another, produce a gaseous reaction that substantially fills the expandable interior inflation space **100** of the flexible inflatable substrate **40** are considered for use.

Although the flexible inflatable substrate **40** is shown in FIGS. 1-2 as being square, the flexible inflatable substrate **40** may be any shape. For example, the flexible inflatable substrate **40** may be square, rectangular, circular or any other geometric or fanciful shape. The shape of the flexible inflatable substrate **40** may even have an irregular, capricious or decorative shape.

To receive the tuft **20**, the exterior surface **120** of the flexible inflatable substrate **40** is coated with a bonding material **130** (which may be the same as the bonding material **90**) such as an adhesive or cohesive whereby the tuft **20** is caused to bond to the exterior surface **120** of the flexible inflatable substrate **40** as illustrated in FIG. 1. As shown in FIG. 2, the bonding material **130** is disposed on the entire exterior surface **120** of the flexible inflatable substrate **40**—i.e., on each of the first sheet of material **50** and the second sheet of material **60**. Alternatively, the bonding material **130** may be applied in such a manner as to substantially coat only one of the first sheet of material **50** or the second sheet of material **60** of the flexible inflatable substrate **40**. It will be further appreciated that the bonding material **130** may be disposed on the first sheet of material **50** and/or the second sheet of material **60** in any of a variety of patterns such as strips, circles, dots or any other geometric or biomorphic shape, including decorative designs, so long as the bonding material **130** is positioned to function in accordance with the presently disclosed and claimed inventive concept(s).

The term “bonding material” as used herein can mean an adhesive, frequently a pressure sensitive adhesive, or a cohesive or any adhesive/cohesive combination, having adhesive qualities (i.e., qualities of adhesion or adhesion/cohesion, respectively) sufficient to effect the connection between portions of the tuft **20** brought into engagement with the flexible inflatable substrate **40**. It will be appreciated that both adhesives and cohesives suitable for the purposes described herein are well known in the art, and both are commercially available.

FIG. 4 schematically illustrates a system **140** for making the individual strips, strands, or units of material **30** in accordance with the presently disclosed and claimed inventive concept(s). The system **140** includes a roll of material **150** supported on a shaft **160** having a brake assembly **170** operably connected thereto for controlling the rate of withdrawal of the roll of material **150**.

The roll of material **150** provides a web of sheet material **180** which is passed through a slitter **190**. The slitter **190** includes a plurality of spaced apart, stationary knives or other conventional cutting mechanism, which slit or cut the web of sheet material **180** into the individual strips, strands, or units of material **30** of into a desired width.

The slitted web of sheet material **180** is thereafter passed into a cutter **200** where the slitted web of sheet material **180** is cut into predetermined lengths so as to form the individual strips, strands, or units of material **30**. From the cutter **200**, the individual strips, strands, or units of material **30** are conveyed by a conveyor unit **210**, which is in the form of a centrifugal blower, to a storage area (not shown) which may be in the form of a suitable bin, packaging machine, or the like.

As an alternative to forming the individual strips, strands, or units of material **30** from the roll of material **150**, it will be appreciated that the individual strips, strands, or units of material **30** may be formed from a polymeric film discharged from a film extrusion die which is then chilled prior to the slitting process. Such a method is disclosed in U.S. Pat. No. 4,292,266, entitled "Process for Making Decorative Grass", issued to Weder et al. on Sep. 29, 1981, which is hereby expressly incorporated herein in its entirety by reference.

As illustrated in FIG. 3, the individual strips, strands, or units of material **30** tend to curl and form folds during the forming process. It will be appreciated that these curls and folds contribute to the resiliency and bulkiness or fluffiness of the tuft **20** produced by amassing and intertwining a plurality of the individual strips, strands, or units of material **30**. It will be further appreciated that the degree to which the individual strips, strands, or units of material **30** are curled and folded can vary dependant on several factors, such as the type of material used to form the individual strips, strands, or units of material **30**.

To assemble the inflatable packaging material **10**, the individual strips, strands, or units of material **30** are amassed and intertwined to form the tuft **20** and then the tuft **20** is bondably connected to the flexible inflatable substrate **40** (FIG. 2). Thereafter, and as shown in FIG. 2A, the means **110** for inflating is activated such that the expandable interior inflation space **100** is inflated and the inflatable packaging material **10** is provided.

FIG. 5 illustrates one use of the inflatable packaging material **10** described above. The inflatable packaging material **10** is shown in its inflated configuration after the means **110** for inflating has been activated (i.e., the expandable interior inflation space **100** is inflated) and is disposed in a basket **220** to support a plurality of articles or objects **230**, such as candies or Easter eggs, for display. More specifically, the inflatable packaging material **10** is positioned in an interior **240** of the basket **220** such that the flexible inflatable substrate **40** substantially conforms to the contour of the interior **240** of the basket **220** thereby lining the interior **240** of the basket **220** with the individual strips, strands, or units of material **30** forming the tuft **20** that is bonded to the flexible inflatable substrate **40** to form the inflatable packaging material **10**. If the second sheet of material **60** of the flexible inflatable substrate **40** is provided with the bonding material **22**, the second sheet of material **60** of the flexible inflatable substrate **40** can be bondably connected to the interior **240** of the basket **220**. In addition, the bonding material **22** on the second sheet of material **60** of the flexible inflatable substrate **40** causes the inflatable packaging material **10** to remain in place in the basket **220**. If the second sheet of material **60** of the flexible inflatable substrate **40** is not provided with the bonding material **22**, the flexible inflatable substrate **40** simply rests in the interior **240** of the basket **220**.

FIG. 6 illustrates a modified inflatable packaging material **10a** which is similar in construction to the inflatable packaging material **10** illustrated in FIG. 1 with the exception that the inflatable packaging material **10a** has elongated sidewalls **250** that upon activating the means **110** for inflating the expandable interior inflation space **100** provide the inflatable

packaging material **10a** with a height **260**. A tuft **20a** similar to the tuft **20** may be connected to the first sheet of material **50** and/or the second sheet of material **60** and/or the elongated sidewalls **250**. It will be appreciated that such a configuration will facilitate insertion of the inflatable packaging material **10a** into a tall square container.

For example, FIG. 7 illustrates the inflatable packaging material **10a** disposed in a tall square container **270** so as to provide an interior **280** of the tall square container **270** with an inflatable packaging material **10a**. The inflatable packaging material **10a** is being used as a packaging material for protecting an article **230** disposed in the tall square container **270**. In this manner, the tuft **20a** of the inflatable packaging material **10a** functions to cushion the plurality of articles or objects **230** during transport.

Referring now to FIGS. 8 and 9, an inflatable packaging material **300** constructed in accordance with the presently disclosed and claimed inventive concept(s) is illustrated. The inflatable packaging material **300** includes a tuft or mass **310** of individual, thin, flexible strips, strands or units of material **320**, commonly referred to as decorative grass or Easter grass (although the tuft **310** may be fabricated from the same or similar material as tuft **20** disclosed hereinabove), disposed upon an exterior surface **330** of an flexible inflatable bag **340**. It will be appreciated that tufts of decorative grass are often packaged loosely in a bag whereby when it is desired to utilize the decorative grass, the bag is opened and the grass removed. The inflatable packaging material **300** is unique in at least one respect in that the flexible inflatable bag **340** is used in conjunction with the tuft **310** on the exterior surface **330** in a manner similar to that described above in relation to the inflatable packaging material **10**. That is, in addition to functioning as a substrate for the tuft **310**, the flexible inflatable bag **340** is capable of being inflated while holding the tuft **310** to thereby clean up the problems associated with loose fill materials and provide a more economical and cushioning packaging material.

The structure of the flexible inflatable bag **340** can be that of any flexible inflatable bag suitable for being used in a packaging manner. For example, the flexible inflatable bag **340** can be fabricated from a sheet of material having a relatively small thickness and being of the type commonly referred to in the art as a "film". More particularly, the sheet of material can be a processed, man-made organic polymer film selected from the group of films consisting of polypropylene, polyvinyl chloride, or combinations thereof. However, it is to be noted that the sheet of material may also be constructed from a material selected from a group of materials consisting of plastic film, cellophane, paper, cloth, or combinations thereof. Alternatively, the flexible inflatable bag **340** may be of the type used typically to package sandwiches, such as a GLAD™ sandwich bag. The flexible inflatable bag **340** may also be a corsage bag, a balloon, a water storage bag, or any flexible bag or container that is capable of being inflated.

The flexible inflatable bag **340** is characterized as having the exterior surface **330** as well as an interior surface **350** with the interior surface **350** defining an expandable interior inflation space **360**. As best shown in FIG. 8, the exterior surface **330** of the flexible inflatable bag **340** is coated with a bonding material **370**, such as an adhesive or cohesive, whereby the tuft **310** is caused to bond to the exterior surface **330** of the flexible inflatable bag **340** upon being disposed on the flexible inflatable bag **340**. The flexible inflatable bag **340** illustrated in FIG. 10 has the bonding material **370** disposed on substantially the entire exterior surface **330**. Alternatively, the bonding material **370** may be applied in such a manner as to

substantially coat only a portion of the exterior surface **330** of the flexible inflatable bag **340**. It will be further appreciated that the bonding material **370** may be disposed on the exterior surface **330** of the flexible inflatable bag **340** in any of a variety of patterns such as strips, circles, dots or any other geometric or biomorphic shape, including decorative designs, so long as the bonding material **370** is positioned to function in accordance with the presently disclosed and claimed inventive concept(s). The tuft **310** is disposed on the flexible inflatable bag **340** in any manner which is known in the art, such as automatically passing the tuft **310** through a tube (not shown) which is disposed generally above the flexible inflatable bag **340**, or the flexible inflatable bag **340** may be dipped, rolled, or dropped into a plurality of tufts **310** such that the tufts **310** stick to the exterior surface **330** of the flexible inflatable bag **340**.

Upon the tuft **310** being placed onto the flexible inflatable bag **340**, the tuft **310** will bondingly connect to the exterior surface **330** of the flexible inflatable bag **340** via the bonding material **370**. After the tuft **310** has been disposed onto the flexible inflatable bag **340**, the flexible inflatable bag **340** may be inflated via a means **380** for inflating the flexible inflatable bag **340** disposed in the expandable interior inflation space **360** to form the inflatable packaging material **300**. The means **380** for inflating the flexible inflatable bag **340** is similar in construction to the means **110** for inflating the flexible inflatable substrate **40** of the inflatable packing material **10** as described hereinabove. It should be appreciated that with the tuft **310** disposed on the flexible inflatable bag **340**, the flexible inflatable bag **340** can be stored, transported, and displayed in a conventional manner when it is in its inflated configuration or in its non-inflated configuration.

In addition to, or as an alternative to coating the exterior surface **330** of the flexible inflatable bag **340** with the bonding material **370**, the tuft **310** may be connected to the exterior surface **330** of the flexible inflatable bag **340** via a bonding material **390** (FIG. 10) provided on the individual strips, strands, or units of material **320** making up the tuft **310**. The bonding material **390** may be an adhesive or cohesive whereby the individual strips, strands, or units of material **320** are caused to stick together when a plurality of the strips, strands, or units of material **320** are amassed to form the tuft **310**. The strips, strands, or units of material **320** may be spot coated wherein the bonding material **390** is disposed as randomly disposed spots on the individual strips, strands, or units of material **320**. It will be appreciated, however, that the bonding material **390** may be applied in such a manner as to substantially cover the strips, strands, or units of material **320**. Further, the bonding material **390** may be disposed on the strips, strands, or units of material **320** in any of a variety of other patterns such as circles, dots or any other geometric or biomorphic shape, including decorative designs, so long as the bonding material **390** is positioned to function in accordance with the presently disclosed and claimed inventive concept(s).

FIG. 11 illustrates one use of the inflatable packaging material **300** described above. The inflatable packaging material **300** is shown disposed in a basket **400** and supporting a plurality of articles or objects **410**, such as candies or Easter eggs, for display. More specifically, a portion of the flexible inflatable bag **340** has been removed so as to expose the tuft **310** while the tuft remains connected to the exterior surface **330** of the flexible inflatable bag **340**.

With the flexible inflatable bag **340** inflatable, the inflatable packaging material **300** may then be positioned in an interior **420** of the basket **400** such that the flexible inflatable bag **340** substantially conforms to the contour of the interior **420** of the

basket **400** and thereby lines the interior **420** of the basket **400** with the plurality of articles or objects **230** being supported by the tuft **310** and the tuft **310** being held in the basket **400**.

It will be appreciated that coating the tuft **310** with a bonding material in the manner discussed above provides an additional advantage of improved object support. That is, with loose packaging materials, objects being packaged often have a tendency to gravitate through the packaging material to the bottom of the container thereby reducing the effectiveness of the packaging material. By providing a bonding material on the individual strips, strands, or units of material **320** making up the tuft **310**, the cohesiveness of the tuft **310** supporting the plurality of articles or objects **410** prevent the plurality of articles or objects **410** from gravitating through the tuft **310**.

As shown in FIG. 8, the exterior surface **330** of the flexible inflatable bag **340** may also be provided with a bonding material **430**. In this instance, the bonding material **430** would be provided with a backing or release strip **440** to protect the bonding qualities of the bonding material **430** and to prevent adjacent bags from bonding to one another during shipping and storage. By providing the exterior surface **330** of the flexible inflatable bag **340** with the bonding material **430** (as shown in FIG. 8), the exterior surface **330** of the flexible inflatable bag **340** can be bondably connected to an interior **420** of the basket **400** to hold the inflatable packaging material **300** in the basket **400**. In addition, the bonding material **430** on the exterior surface **330** of the flexible inflatable bag **340** will cause overlapping portions of the flexible inflatable bag **340** to be bondably connected so as to retain the shape of the flexible inflatable bag **340** after it has been shaped to conform to the contour of the interior **240** of the basket **400**. If the exterior surface **330** of the flexible inflatable bag **340** is not provided with the bonding material **430**, the flexible inflatable bag **340** is simply shaped to conform to the contour of the interior **420** of the basket **400**.

In using the inflatable packaging material **300** described above, it should be appreciated that a single unit of the inflatable packaging material **300** can be used in a container or on a surface or multiple units of the inflatable packaging material **300** can be used by either nesting one inflatable packaging material **300** into another inflatable packaging material **300** or otherwise layering one inflatable packaging material **300** on top of another inflatable packaging material **300**, thereby increasing the volume and/or density of the inflatable packaging material **300**.

Referring to FIGS. 12-14, shown therein is an inflatable packaging material **10b** constructed in accordance with the presently disclosed and claimed inventive concept(s). The inflatable packaging material **10b** is similar in construction to the inflatable packaging material **10**. The inflatable packaging material **10b** includes a flexible inflatable substrate **40b**, a decorative extension **12b** and the tuft **20b**. The tuft **20b** is similar to the tuft **20a**. The tuft **20b** is connected to the flexible inflatable substrate **40b** in a manner similar to the manner in which the tuft **20** is connected to the flexible inflatable substrate **40**. The tuft **20b** includes the plurality of individual strips, strands, or units of material **30b** similar to the plurality of individual strips, strands or units of material **30** and can be, for instance, bondably connected to the flexible inflatable substrate **40b**. The flexible inflatable substrate **40b** includes an exterior surface **41b**, and interior surface **42b**, an inner area **43b** substantially surrounded by an inner seal **44b** and a distal edge **45b**. In one embodiment the decorative extension **12b** extends outwardly from at least a portion of the inner seal **44b** to at least a portion of the distal edge **45b**.

The flexible inflatable substrate **40b** is fabricated of a first sheet of material **50b** and a second sheet of material **60b**

similar in construction to the first sheet of material **50** and the second sheet of material **60**, respectively. It will be appreciated that the dimensions of the flexible inflatable substrate **40b** may be varied and the shape of the flexible inflatable substrate **40b** may be variable—e.g., a circle, square, triangle, heart, an animal shape, a floral shape, etc. The first sheet of material **50b** and the second sheet of material **60b** can be any flexible sheet of material, such as paper, wax paper, polymeric film, laminated polymeric film, fabric, cellulose, and foil. The first sheet of material **50b** and the second sheet of material **60b** may have printing and embossing on all or a part of at least one side thereof, and the embossing can be either in register or out of register with the printing. Different colors can be employed to provide the printing on the first sheet of material **50b** and the second sheet of material **60b**. For example, the printing may be a pictorial representation, or color, or shape of the plurality of individual strips, strands, or units of material **30b** such that when a small amount of the plurality of individual strips, strands, or units of material **30**, forming the tuft **20b** are bonded to the flexible inflatable substrate **40b**, the printing fills in the voids between the plurality of individual strips, strands, or units of material **30b**. The printing provides the illusion that there are few or no actual voids of the plurality of individual strips, strands, or units of material **30b** on the flexible inflatable substrate **40b** thereby resulting in an aesthetically pleasing inflatable packaging material **10b** that appears to be fully covered with the individual strips, strands, or units of material **30b**.

The first sheet of material **50b** and the second sheet of material **60b** of the flexible inflatable substrate **40b** may be constructed of a single layer of material or a plurality of layers of the same or different types of materials. In addition, any thickness of the first sheet of material **50b** and the second sheet of material **60b** may be utilized with the presently disclosed and claimed inventive concept(s). The first sheet of material **50b** has an inner perimeter **52b**, an inner area **53b** surrounded by the inner perimeter **52b**, an outer peripheral edge **54b** and an outer area **56b** between the inner perimeter **52b** and the outer peripheral edge **54b**.

The second sheet of material **60b** has an inner perimeter **62b**, an inner area **63b** surrounded by the inner perimeter **62b** substantially sized and shaped to mate with the inner perimeter **52b** and inner area **53b**, respectively, of the first sheet of material **50b** such that as the first sheet of material **50b** and the second sheet of material **60b** are disposed in a coplanar, parallel and aligned configuration the sealing of the inner perimeter **52b** of the first sheet of material **50b** to the inner perimeter **62b** of the second sheet of material **60b** provides the inner seal **44b** for the flexible inflatable substrate **40b**. In one embodiment the second sheet of material **60b** also has an outer peripheral edge **64b** and an outer area **66b** between the inner perimeter **62b** and outer peripheral edge **64b**. The outer area **56b** of the first sheet of material **50b** can be bonded to the outer area **66b** of the second sheet of material **60b** to provide the decorative extension **12b** for the inflatable packaging material **10b** and the outer peripheral edge **54b** of the first sheet of material **50b** and the outer peripheral edge **64b** of the second sheet of material **60b** provides the distal edge **45b** for the flexible inflatable substrate **40b**. The inner perimeter **52b** of the first sheet of material **50b** can be sealed via bonding or welding the inner perimeter **66b** of the second sheet of material **60b** to provide and define an expandable interior inflation space **100b**. A means **110b** for inflating similar in construction to the means **110** for inflating, previously described herein, is disposed within the expandable interior inflation space **100b**. The flexible inflatable substrate **40b** is inflated by the means **110b** for inflation.

Although the flexible inflatable substrate **40b** is shown in FIGS. **12-14** as having the inner area **43b** being substantially round and the distal edge **45b** being scalloped, the inner area **43b** and the distal edge **45b** of the flexible inflatable substrate **40b** may be any shape. For example, the inner area **43b** and/or the distal edge of the flexible inflatable substrate **45b** may be square, rectangular, oval, oblong, triangular, hexagonal or any other geometric or fanciful shape. The distal edge **45b** of the flexible inflatable substrate **40b** may also be any shape or even have an irregular, capricious or decorative shape. The tuft **20b** is attached to the exterior surface **120b** of the flexible inflatable substrate **40b** in substantially the same way as the tuft **20** is attached to the flexible inflatable substrate **40**. The tuft **20b** can be sized and configured to cover all or only a portion of the exterior surface **120b** of the flexible inflatable substrate **40b**. The tuft **20b** can also be sized, configured and disposed to cover all or a portion of the decorative extension **12b**.

FIG. **14** illustrates one use of the inflatable packaging material **10b** described above. The inflatable packaging material **10b** is shown in its inflated condition after the means **110b** for inflating has been activated (i.e., the expandable interior inflation space **100b** is inflated) and is disposed in a basket **220b** to support a plurality of articles or objects **230b**, such as candies or Easter eggs, for display. More specifically, the inflatable packaging material **10b** is positioned in an interior **240b** of the basket **220b** such that the inner area **43b** of the flexible inflatable substrate **40b** substantially conforms to the contour of the interior **240b** of the basket **220b** thereby lining the interior **240b** of the basket **220b** with the individual strips, strands, or units of material **30b** forming the tuft **20b** that is bonded to the flexible inflatable substrate **40b** to form the inflatable packaging material **10b** and the decorative extension **12b** extends generally above an upper edge **242b** of the basket **220b**. If the second sheet of material **60b** of the flexible inflatable substrate **40b** is provided with the bonding material **22b**, the second sheet of material **60b** of the flexible inflatable substrate **40b** can be bondably connected to the interior **240b** of the basket **220b**. In addition, the bonding material **22b** on the second sheet of material **60b** of the flexible inflatable substrate **40b** causes the inflatable packaging material **10b** to remain in place in the basket **220b**. If the second sheet of material **60b** of the flexible inflatable substrate **40b** is not provided with the bonding material **22b**, the flexible inflatable substrate **40b** simply rests in the interior **240b** of the basket **220b**.

Referring now to FIG. **15** shown therein is a packaging material **500** constructed in accordance with the presently disclosed and claimed inventive concept(s). The packaging material **500** includes a substratum **504** and a printed pattern **506** simulating a grass-like pattern disposed on at least a portion of the substratum **504** so as to provide the substratum with a grass-like appearance. Although the substratum **504** is shown in FIG. **15** as rectangular, the substratum **504** may be any shape. For example, the substratum **504** may be square, triangular, hexagonal, circular or any other geometric shape. The substratum **504** may even have an irregular or non-linear, capricious or decorative shape.

The substratum **504** can be constructed of any non-inflatable cushioning and/or resilient type of material capable of supporting and cushioning an object such as sponge-like material such as, by way of example but not limitation, natural sponge, artificial sponge, polymeric material, cloth, paper, cardboard, cellulose, papier-mâché or combinations, derivations and laminations thereof. The substratum **504** may be constructed of a single layer of material or a plurality of layers of the same or different types of material. In addition, any

thickness of substratum 504 may be utilized in the presently disclosed and claimed inventive concept(s). Preferably, the substratum 504 is substantially conformable to the general contour of an interior surface 507 of a container 508 and the substratum 504 is capable of supporting and cushioning an object 510 disposed on the substratum 504. A plurality of the substratum 504 may be disposed in the container 508. The plurality of the substratum 504 is preferably substantially conformable to the general contour of the interior surface 507 of the container 508 and capable of cushioning the object 510 supported by the plurality of the substratum 504.

The substratum 504 can also be embossed so as to provide the substratum 504 with an embossed pattern 512. The embossed pattern 512 can be either in register or out of register with the printed pattern 506. The embossing can cover all or only a portion of the substratum 504.

Different colors can be employed to provide the printed pattern 506 on the substratum 504. The printed pattern 506 can be disposed on the entire exterior surface 516 of the substratum 504 or the printed pattern 506 can be disposed on only a portion of the substratum 504.

A bonding material 520 may be applied to all or at least a portion of the substratum 504. The term "bonding material" as used herein can mean an adhesive, frequently a pressure sensitive adhesive, or a cohesive or any adhesive/cohesive combination having adhesive qualities (i.e., qualities of adhesion or adhesion/cohesion, respectively) sufficient to affect the connection between portions of the substratum 504 and portions of the container 508 and/or an object supported by the substratum 504 brought into engagement with the substratum 504. It will be appreciated that both adhesives and cohesives, for the purposes described herein, are well-known in the art, and commercially available.

The bonding material 520 may be applied in such a manner so as to substantially coat only a first surface 524 or only a second surface 528 of the substratum 504. It will further be appreciated that the bonding material 520 may be disposed on the first surface 524 and/or the second surface 528 in any variety of patterns such as strips, circles, dots, or any other geometric or biomorphic shape, including decorative designs so long as the bonding material 520 is positioned to function in accordance with the presently disclosed and claimed inventive concept(s).

The printed pattern 506 may be any printed pattern or any pictorial representational color or shape, such as a printed pattern simulating the grass-like appearance of the tuft 20c such that when a small amount of the plurality of individual strips strands, or units of material 30c forming a tuft 20c are bonded to the substratum 504, the printed pattern 506 fills voids between the plurality of individual strips, strands or units of material 30c such that it provides the illusion that there are few or no actual voids of the plurality of individual strips, strands or units of material 30c on the substratum 504 thereby resulting in an aesthetically pleasing packaging material 500 that appears to be fully covered with the individual strips, strands, or units of material 30c.

The packaging material 500 can also include at least one decorative extension 532 that extends outwardly from at least a portion of the substratum 504. The decorative extension 532 can be fabricated from any sheet of material including but not limited to paper, crepe paper, polymeric film, laminated polymeric film, cardboard, papier-mâché, cloth or combinations, laminations, and derivations thereof. The decorative extension 532 can include an interior expandable space 533 and a means for inflating the interior expandable space 533 so as to allow the decorative border 532 to be inflatable. The decorative extension 532 can include printing 536 disposed on at

least a portion of the decorative extension 532. The decorative extension 532 can also include embossing 540. Printing 536 and embossing 540 on the decorative extension 532 can be in register or out of register. Different colors can be employed to provide the printing 536 on the decorative extension 532. The decorative extension 532 can extend entirely around substratum 504 or the decorative extension 532 can extend only around a portion of the substratum 504. Although the shape of the decorative extension 532 is shown as substantially scalloped the shape of the decorative extension 532 can be any geometric, or non-geometric, or linear, or non-linear decorative or even fanciful shape. All or a portion of the decorative extension 532 can be bonded to the substratum 504 or frictionally secured to the substratum 504. Furthermore, the decorative extension 532 can be secured to the substratum 504 via securing elements such as by way of example but not limitation rubber bands, elastic bands, clips, thread, twine, string, cloth or staples or combinations and derivations thereof. The decorative extension 532 can be sized, shaped, and configured such that the decorative extension 532 extends above the container 508 into which the substratum 504 and the decorative extension 532 are disposed or the decorative extension 532 can be sized, shaped and configured such that the decorative extension 532 is even with or below the container 508 into which the substratum 504 and the decorative extension 532 are disposed. The decorative extension 532 can include a means for conveniently removing the decorative extension 532 from the substratum 504 via a detaching element such as a tear strip, score line or a plurality of perforations.

Referring now to FIG. 16 shown therein is packaging material 600 similar to the packaging material 500. The packaging material 600 includes a substratum 604 similar to the substratum 504, except the substratum 604 does not include the printing 508. The packaging material 600 does include individual strips, strands or units of material 30d disposed on the substratum 604. The individual strips, strands or units of material 30d can be bondably connected to the substratum 604. The packaging material 600 can also include at least one decorative extension 610, similar to the decorative extension 532, bonded to the substratum 604 or frictionally connected to the substratum 604 or secured to the substratum 604 via the securing elements such as elastic bands, rubber bands, strips of cloth, staples, twine, or string or otherwise at least partially secured or associated with the substratum 604. The decorative extension 610 can include a printed pattern 612 similar to the printed pattern 536 and embossing 614 similar to the embossing 540.

The individual strips, strands or units of material 30d can be intertwined to form a cohesive mass of strips, strands and units of material 20d for connection to or disposition on the substratum 604 or the individual strips, strands and units of material 30d can include a bonding material disposed on at least a portion of the mass of individual strips, strands and units of material to form a cohesive mass of strips, strands and units of material connected to the substratum 604. Furthermore, the individual strips, strands or units of material 30d can be both intertwined and include the bonding material to form a cohesive mass of strips, strands and units of material 20d connected to the substratum 604.

Referring now to FIG. 17 shown therein is a packaging material 700 similar to the packaging material 500 and the packaging material 600. The packaging material 700 includes a substratum 704 adapted to support and/or cushion at least one object 706. The substratum 704 includes at least one depression 708 sized and configured to receive at least a portion 710 of the object 706. The packaging material 700 can

15

also include a decorative extension 714 similar to the decorative extension 532 and the decorative extension 632. The decorative extension 714 can include printing and embossing similar to the printing and embossing on the decorative extensions 532 and 632 of packaging material 500 and packaging material 600, respectively. The packaging material 700 also includes the mass of individual strips, strands or units of material 30e connected to the substratum 704. In one embodiment of the packaging material 700, the at least one depression 708 is substantially semi-elliptically configured, sized and shaped to receive at least a portion of at least one substantially egg-shaped object 706.

FIG. 18 illustrates one use of the packaging material 700. The packaging material 700 is positioned in an interior 740 of a basket 750 such that the substratum 704 substantially conforms to the general contour of the interior 740 of the basket 750 thereby lining the interior 740 of the basket 750 and providing the at least one depression 708 in the substratum 704 sized and configured to receive at least a portion 710 of at least one substantially egg shaped object 706 disposed in the depression 708 of the substratum 704. Surrounding the substantially egg-shaped object 706 disposed in the depression 708 of the substratum 704 is the mass of individual strips, strands or units of material 30e so as to provide a pleasing and decorative appearance. The decorative extension 714 extends outwardly from the substratum 704 to add to the overall decorative effect. The individual strips, strands or units of material 30e can be constructed of at least one clear layer of polymeric film laminated to at least one layer of iridescent polymeric film so as to provide an iridescent effect to the packaging material 700. The packaging material 700 can be secured to the basket 750 via bonding material or securing elements or the packaging material 700 can be secured to the basket 750 via a combination of bonding materials, securing elements and/or frictionally secured.

From the above description it is clear that the presently disclosed and claimed inventive concept(s) is well adapted to carry out the objects and to attain the advantages mentioned herein as well as those inherent in the presently disclosed and claimed inventive concept(s). While presently preferred embodiments of the inventive concept(s) have been described for purposes of this disclosure, it will be understood that numerous changes may be made which will readily suggest themselves to those skilled in the art and which are accomplished within the spirit of the inventive concept(s) disclosed and as defined in the appended claims.

What is claimed:

1. A package, comprising:

a container having an interior;

a packaging material disposed within the interior of the container, the packaging material comprising a substratum adapted to support and cushion an object, wherein the substratum is a flexible inflatable substrate having an exterior surface and an interior surface, wherein the interior surface defines an expandable interior inflation space, the packaging material further comprising:

(a) at least one strip, strand, or unit of material disposed on a surface of the substratum and within the interior of the container; and/or

16

(b) a printed pattern disposed on at least a portion of the substratum, the printed pattern comprising a plurality of individual strips, strands, or units of material, thereby providing the substratum with a grass-like appearance; and

at least one object disposed on the packaging material and within the interior of the container, whereby the packaging material supports and cushions the object within the interior of the container.

2. The package of claim 1, wherein the packaging material further includes an inflation assembly for inflating the flexible inflatable substrate, and wherein at least one of:

(a) the inflation assembly is disposed in the expandable interior inflation space of the flexible inflatable substrate;

(b) the inflation assembly is associated with the exterior surface of the flexible substrate and is in fluid communication with the expandable interior inflation space of the flexible inflatable substrate; and

(c) the inflation assembly includes an exothermic reaction assembly, wherein when the exothermic reaction assembly is activated, an exothermic reaction takes place thereby producing a gas capable of filling at least a portion of the expandable interior inflation space of the flexible substrate.

3. The package of claim 1, wherein the exterior surface of the flexible inflatable substrate of the packaging material includes a decorative effect.

4. The package of claim 1, wherein the container is a basket.

5. The package of claim 1, wherein the at least one object comprises at least one candy and/or Easter egg.

6. The package of claim 1, wherein the packaging material is bondingly connected to the interior of the container.

7. The package of claim 1, wherein the object is bondingly connected to the packaging material.

8. The package of claim 1, wherein (a) is further defined as a plurality of strands of decorative grass.

9. The package of claim 1, wherein the packaging material substantially conforms to a contour of the interior of the container and thereby lines the interior of the container with the at least one object being supported by the packaging material held within the interior of the container.

10. The packaging material of claim 1, wherein the substratum is constructed of sponge-like material.

11. The packaging material of claim 1, further comprising at least one depression formed in the substratum, wherein the at least one depression is substantially elliptically configured and sized to receive at least a portion of at least one substantially egg-shaped object.

12. The package of claim 1, wherein the packaging material further includes a decorative extension extending outwardly from at least a portion of the substratum.

13. The package of claim 12, wherein the decorative extension includes embossing on at least a portion of the decorative extension.

14. The package of claim 12, further comprising a printed pattern simulating the appearance of decorative grass disposed on at least a portion of the decorative extension.

* * * * *

UNITED STATES PATENT AND TRADEMARK OFFICE
CERTIFICATE OF CORRECTION

PATENT NO. : 8,968,847 B2
APPLICATION NO. : 14/134719
DATED : March 3, 2015
INVENTOR(S) : Donald E. Weder

Page 1 of 1

It is certified that error appears in the above-identified patent and that said Letters Patent is hereby corrected as shown below:

On the Title Page:

Under (71) Applicant: After "Family Trust," insert -- U/T/A dated 12/8/1995 --

Signed and Sealed this
Twenty-seventh Day of October, 2015

Michelle K. Lee
Director of the United States Patent and Trademark Office