

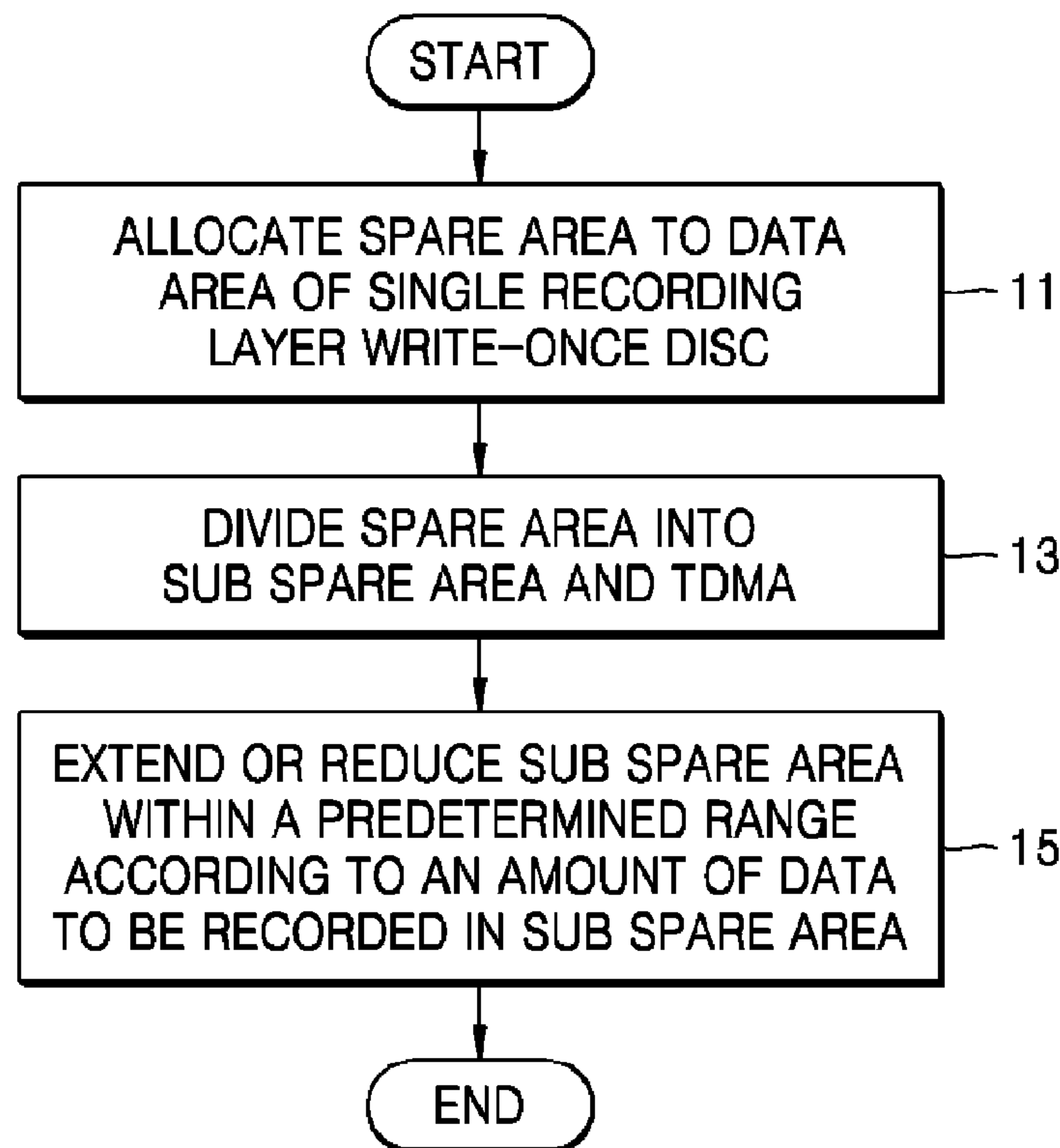

(86) Date de dépôt PCT/PCT Filing Date: 2004/09/24
 (87) Date publication PCT/PCT Publication Date: 2005/04/07
 (45) Date de délivrance/Issue Date: 2012/04/10
 (85) Entrée phase nationale/National Entry: 2006/03/24
 (86) N° demande PCT/PCT Application No.: KR 2004/002479
 (87) N° publication PCT/PCT Publication No.: 2005/031741
 (30) Priorité/Priority: 2003/09/30 (KR10-2003-0067917)

(51) Cl.Int./Int.Cl. *G11B 20/12* (2006.01)
 (72) Inventeurs/Inventors:
 HWANG, SUNG-HEE, KR;
 KO, JUNG-WAN, KR
 (73) Propriétaire/Owner:
 SAMSUNG ELECTRONICS CO., LTD., KR
 (74) Agent: RIDOUT & MAYBEE LLP

(54) Titre : DISQUE NON EFFACABLE, PROCEDE D'UTILISATION DE CE DISQUE, ET APPAREIL D'ENREGISTREMENT ET/OU DE REPRODUCTION DE DONNEES
 (54) Title: WRITE-ONCE DISC, METHOD OF USING WRITE-ONCE DISC, AND DATA RECORDING AND/OR REPRODUCING APPARATUS



(57) **Abrégé/Abstract:**

Provided are a write-once disc, a method of using the write-once disc, and a data recording and/or reproducing apparatus. The method includes: allocating at least one spare area to a data area of the recording layers; and dividing each spare area into a sub spare area and a temporary disc management area in the direction in which user data is recorded. Here, the size of the temporary disc management area is greater than or equal to 1/N (N is a real number) of the size of one spare area.

(12) INTERNATIONAL APPLICATION PUBLISHED UNDER THE PATENT COOPERATION TREATY (PCT)

(19) World Intellectual Property
Organization
International Bureau



(43) International Publication Date
7 April 2005 (07.04.2005)

PCT

(10) International Publication Number
WO 2005/031741 A1

(51) International Patent Classification⁷: **G11B 20/12**

[KR/KR]; 420-403 Jugong Apt., 189, Gaepo-dong, Gangnam-gu, Seoul 135-240 (KR). **KO, Jung-Wan** [KR/KR]; 114-1101 Byucksan Apt., Mangpo-dong, Yeongtong-gu Suwon-si, Gyeonggi-do 442-707 (KR).

(21) International Application Number:
PCT/KR2004/002479

(22) International Filing Date:
24 September 2004 (24.09.2004)

(74) Agent: **LEE, Young-Pil**; The Cheonghwa Building, 1571-18, Seocho-dong, Seocho-gu, Seoul 137-874 (KR).

(25) Filing Language: English

(81) Designated States (unless otherwise indicated, for every kind of national protection available): AE, AG, AL, AM, AT, AU, AZ, BA, BB, BG, BR, BW, BY, BZ, CA, CH, CN, CO, CR, CU, CZ, DE, DK, DM, DZ, EC, EE, EG, ES, FI, GB, GD, GE, GH, GM, HR, HU, ID, IL, IN, IS, JP, KE, KG, KP, KZ, LC, LK, LR, LS, LT, LU, LV, MA, MD, MG, MK, MN, MW, MX, MZ, NA, NI, NO, NZ, OM, PG, PH, PL, PT, RO, RU, SC, SD, SE, SG, SK, SL, SY, TJ, TM, TN, TR, TT, TZ, UA, UG, US, UZ, VC, VN, YU, ZA, ZM, ZW.

(26) Publication Language: English

(30) Priority Data:
10-2003-0067917
30 September 2003 (30.09.2003) KR

(71) Applicant (for all designated States except US): **SAM-SUNG ELECTRONICS CO., LTD.** [KR/KR]; 416, Maetan-dong, Yeongtong-gu, Suwon-si, Gyeonggi-do 442-742 (KR).

(72) Inventors; and

(75) Inventors/Applicants (for US only): **HWANG, Sung-Hee**

(84) Designated States (unless otherwise indicated, for every kind of regional protection available): ARIPO (BW, GH, GM, KE, LS, MW, MZ, NA, SD, SL, SZ, TZ, UG, ZM,

[Continued on next page]

(54) Title: WRITE-ONCE DISC, METHOD OF USING WRITE-ONCE DISC, AND DATA RECORDING AND/OR REPRODUCING APPARATUS

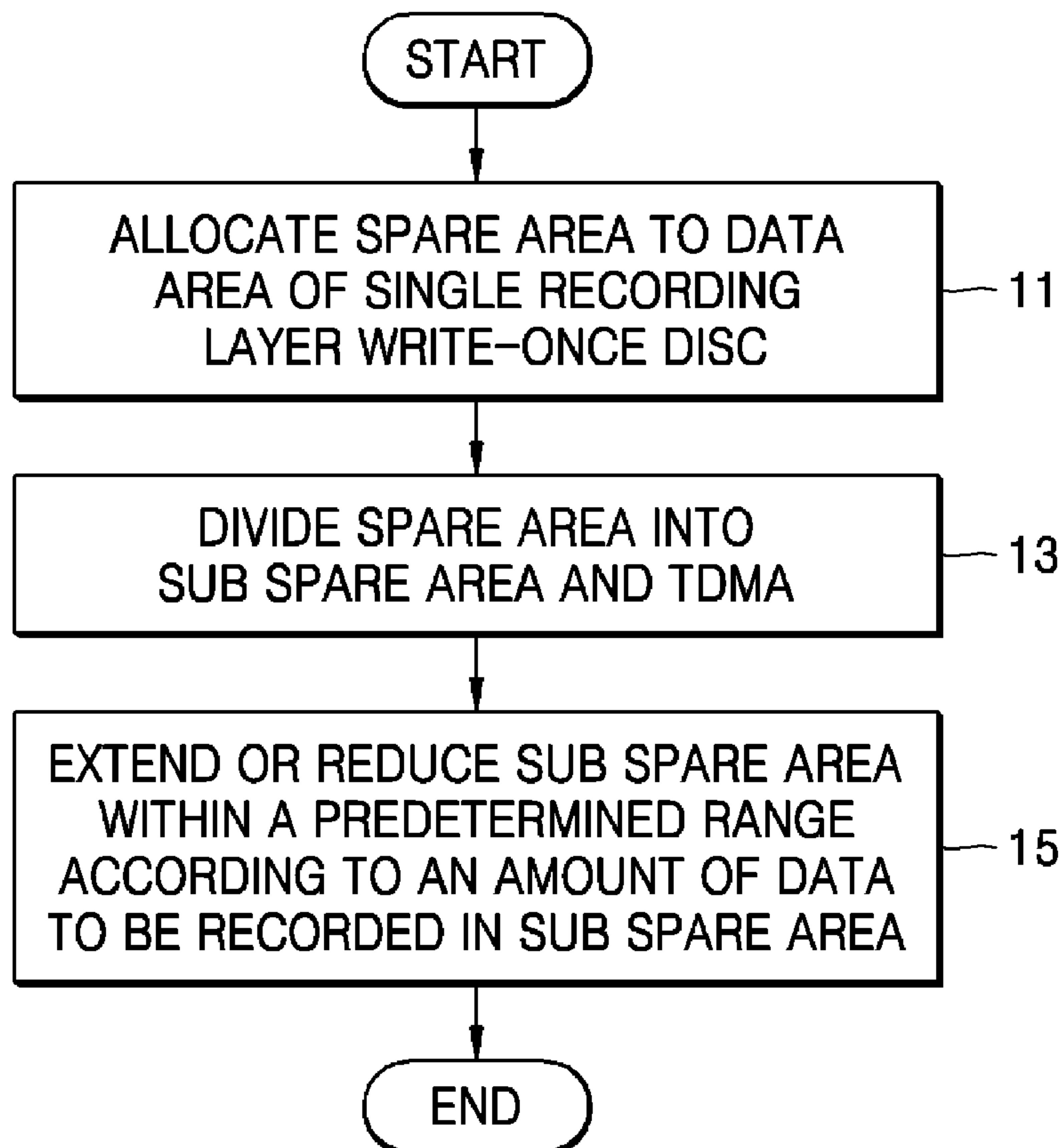

(57) Abstract: Provided are a write-once disc, a method of using the write-once disc, and a data recording and/or reproducing apparatus. The method includes: allocating at least one spare area to a data area of the recording layers; and dividing each spare area into a sub spare area and a temporary disc management area in the direction in which user data is recorded. Here, the size of the temporary disc management area is greater than or equal to $1/N$ (N is a real number) of the size of one spare area.

WO 2005/031741 A1

WO 2005/031741 A1



ZW), Eurasian (AM, AZ, BY, KG, KZ, MD, RU, TJ, TM),
European (AT, BE, BG, CH, CY, CZ, DE, DK, EE, ES, FI,
FR, GB, GR, HU, IE, IT, LU, MC, NL, PL, PT, RO, SE, SI,
SK, TR), OAPI (BF, BJ, CF, CG, CI, CM, GA, GN, GQ,
GW, ML, MR, NE, SN, TD, TG).

For two-letter codes and other abbreviations, refer to the "Guidance Notes on Codes and Abbreviations" appearing at the beginning of each regular issue of the PCT Gazette.

Published:

— *with international search report*

Description

WRITE-ONCE DISC, METHOD OF USING WRITE-ONCE DISC, AND DATA RECORDING AND/OR RE-PRODUCING APPARATUS

Technical Field

- [1] The present invention relates to a write-once disc, and more particularly, to a write-once disc, a method of using the write-once disc, and a data recording and/or reproducing apparatus.

Background Art

- [2] A write-once disc is an information storage medium which can be recorded onto only once. Thus, a user cannot delete or change information recorded on the write-once disc.
- [3] Such a write-once disc additionally includes a spare area and a temporary disc management area (TDMA) in order to record information related to defect management or file system information including several kinds of information related to data recorded on the write-once disc in consideration of the characteristics of the write-once disc.
- [4] Defect management refers to re-recording a defective portion of user data recorded in a user data area of an information storage medium in a spare area in order to prevent loss of data caused by the defect.
- [5] The defect management method of the write-once disc will be explained in more detail. A drive records data on the write-once disc in predetermined units and then verifies the recorded data using a verify-after-write method to find defective positions on the write-once disc. The drive re-records data from the defective positions in a spare area, and generates a Temporary DeFect List (TDFL) indicating the defective positions and corresponding positions in the spare area, and a Temporary Disc Definition Structure (TDDS) indicating the position in which the TDFL is recorded.
- [6] The drive stores the TDFL or TDDS in a memory, collects a predetermined amount of the TDFL or TDDS, and records the predetermined amount of the TDFL or TDDS in the TDMA. Continuous recording of data on the write-once disc contributes to updating the TDFL or TDDS recorded in the TDMA.
- [7] Also, file system information updated due to recording of data in the spare area is recorded using the above-described defect management and a logical over-write function. The logical over-write function refers to the update of information recorded

in a logical address by changing the physical address of a disc corresponding to the logical address without changing the logical recording portion of the disc, i.e., the logical address.

[8] The update of the file system information on the write-once disc will be described in more detail. The drive checks whether data is recorded in a physical address of the write-once disc corresponding to a logical address of the file system information, in compliance with a file system update command of a host. When the drive checks that the data has been recorded in the physical address, the drive determines that the physical address area is a defective area and then records updated file system information in the spare area.

[9] The above-described spare area is allocated within a data area during initialization of the write-once disc. An area outside the data area, i.e., a lead-in area or a lead-out area, includes at least one TDMA. However, a portion of the spare area may be allocated as a TDMA during the initialization of the write-once disc.

[10] Also, when the amount of data to be recorded in the spare area is larger than expected, the spare area may be extended. However, the amount of data recorded in the spare area is proportional to the amount of data recorded in the TDMA. In other words, when the amount of data to be recorded in the spare area is large, an amount of data to be recorded in the TDMA increases. Thus, the spare area must be extended or reduced according to the size of the TDMA.

Disclosure of Invention

Technical Solution

[11] The present invention provides a write-once disc, a method of using the write-once disc so as to further efficiently use a data area, and a data recording and/or reproducing apparatus.

Advantageous Effects

[12] According to the present invention, a spare area and a TMDA can be allocated in the write-once disc. Also, the spare area can be extended or reduced according to the size of the TMDA. As a result, a data area of the write-once disc can be more efficiently used.

Description of Drawings

[13] The above and other features and advantages of the present invention will become more apparent by describing in detail exemplary embodiments thereof with reference to the attached drawings in which:

[14] FIG. 1A is a view showing the structure of a write-once disc according to an

embodiment of the present invention;

[15] FIG. 1B is a view showing the structure of a write-once disc according to another embodiment of the present invention;

[16] FIG. 2 is a view showing the structure of a recording layer of a single recording layer write-once disc or a first recording layer of a dual recording layer write-once disc;

[17] FIGS. 3A and 3B are views showing the structure of a recording layer of a write-once disc in which spare areas are allocated to a data area, according to an embodiment of the present invention;

[18] FIGS. 4A and 4B are views showing the sizes of spare area 2 and TDMA 2 of FIGS. 3A and 3B;

[19] FIGS. 5A and 5B are views showing the structure of recording layer L1 of a dual recording layer write-once disc in which spare areas and a TDMA are allocated to a data area, according to an embodiment of the present invention;

[20] FIG. 6 is a block diagram of a data recording and/or reproducing apparatus according to an embodiment of the present invention; and

[21] FIG. 7 is a flowchart of a method of using a single recording layer write-once disc, according to an embodiment of the present invention.

Best Mode

[22] According to an aspect of the present invention, there is provided a method of using a write-once disc comprising at least one recording layer, including: allocating at least one spare area to a data area of the recording layers; and dividing each spare area into a sub spare area and a temporary disc management area in the direction in which user data is recorded. Here, the size of the temporary disc management area is greater than or equal to $1/N$ (N is a real number) of the size of one spare area.

[23] According to another aspect of the present invention, there is provided a data recording and/or reproducing apparatus including: a recording and/or reading unit which records data on and/or reads data from a write-once disc comprising at least one recording layer; and a controller which allocates at least one spare area to a data area of the recording layers, divides each spare area into a sub spare area and a temporary disc management area in the direction in which user data is recorded, and controls the recording and/or reading unit to record information on the position and/or size of each spare area and information on the position and/or size of the sub spare area and the temporary disc management area on the write-once disc. Here, the controller determines the size of the temporary disc management area to be greater than or equal

to $1/N$ of the size of one spare area.

[24] According to still another aspect of the present invention, there is provided a single recording layer write-once disc on which user data is recorded from the inside out, including a recording layer which comprises a data area. The data area includes a spare area which is allocated to an area ranging from a predetermined position of the data area to the last position of the data area and which is divided into a sub spare area and a temporary disc management area from the inside out. Here, the size of the temporary disc management area is greater than or equal to $1/N$ (N is a real number) of the size of the spare area.

[25] According to yet another aspect of the present invention, there is provided a dual recording layer write-once disc including: a first recording layer on which user data is recorded using an opposite track path method; and a second recording layer which comprises a data area. Here, an area ranging from a predetermined position of the data area to the last position of the data area is allocated as a spare area which is divided into a sub spare area and a temporary disc management area from the outside in, and the size of the temporary disc management area is greater than or equal to $1/N$ (N is a real number) of the size of the spare area.

Mode for Invention

[26] Embodiments of the present invention will be described in detail with reference to the attached drawings.

[27] In the present invention, when a spare area is allocated to a data area during initialization of a write-once disc and then divided into a sub spare area and a TDMA, the sub spare area may be extended or reduced within a predetermined range according to the size of the TDMA, so as to more efficiently use the data area or the spare area of the write-once disc.

[28] FIG. 1A is a view showing the structure of a write-once disc according to an embodiment of the present invention, and FIG. 1B is a view showing the structure of a write-once disc according to another embodiment of the present invention. FIG. 1A shows a single recording layer write-once disc, and FIG. 1B shows a dual recording layer write-once disc.

[29] Referring to FIG. 1A, the single recording layer write-once disc includes inner area 0, data area 0, and outer area 0. The data area 0 includes spare area 1, user data area 1, and spare area 2. Referring to FIG. 1B, the dual recording layer write-once disc includes recording layers L0 and L1. Here, each of the recording layers L0 and L1 has the same structure as recording layer L0 of the single recording layer write-once disc

of FIG. 1A.

- [30] FIG. 2 is a view showing the structure of the recording layer L0 of the single recording layer write-once disc or the recording layer L0 of the dual recording layer write-once disc. Referring to FIG. 2, inner area 0 includes disc management area 1 (DMA 1), a recording condition test area, a TDMA 1, and DMA 2. Data area 0 includes spare area 1, user data area 1, and spare area 2. The spare area 2 is divided into sub spare area 2 and TDMA 2. The spare areas 1 and 2 are allocated to pre-determined positions of the data area 0 during initialization of the write-once disc according to the selection of a user or the command of a drive. The spare area 2 is divided into the sub spare area 2 and the TDMA 2 according to a selection of the user or a command of the drive.
- [31] Here, a TDMA refers to an area in which defect management information, temporary disc management information, and the like are recorded. The defect management information includes a TDFL and a TDDS, and the temporary disc management information includes a space bit map (SBM) for representing the data recording state of the write-once disc using different bit values, a last recorded address (LRA) of a user data area, and the like.
- [32] According to an aspect of the present invention, a spare area may be allocated to a data area and then divided into a sub spare area and a TDMA. Here, the temporary disc management information includes information as to whether the spare area has been allocated to the data area, information as to the position and size of the spare area, and information as to the positions and sizes of the sub spare area and the TDMA into which the spare area allocated to the data area is divided.
- [33] A DMA refers to an area in which final disc defect information and temporary disc management information recorded in a TDMA are recorded during finalization of the write-once disc.
- [34] FIGS. 3A and 3B are views showing the structure of recording layer L0 of a single recording layer write-once disc or a dual recording layer write-once disc including a data area to which spare areas and a TDMA are allocated, according to an embodiment of the present invention. Referring to FIG. 3A, spare areas 1 and 2 are allocated to data area 0 during initialization of the write-once disc. The remainder of the data area 0, except the spare areas 1 and 2, i.e., a user data area, is used from the inside out as shown in FIG. 3A. The spare area 1 is used from the inside out, while the spare area 2 is used from the outside in. If a spare area needs to be extended, the spare area 2 is used from the outside in.

- [35] In general, a spare area which replaces a defective area occupies about 5% of the entire capacity of a write-once disc. However, when updated file system information is recorded in the spare area using logical over-write (LOW) and defect management, the size of the spare area does not need to be larger. In the present invention, a spare area is allocated in advance during initialization of a write-once disc and extended within a predetermined range if necessary.
- [36] Referring to FIG. 3B, the spare areas 1 and 2 are allocated to the data area 0 as shown in FIG. 3A, and then the spare area 2 is divided into sub spare area 2 and TDMA 2.
- [37] FIGS. 4A and 4B are views showing the sizes of the spare area 2 and the TDMA 2 of FIGS. 3A and 3B.
- [38] In the present embodiment, the size of the TDMA 2 in the spare area 2 is greater than or equal to 1/4 of the size of the spare area 2. However, the ratio of the size of the TDMA 2 to the size of the spare area 2 is not limited to this and may vary.
- [39] Referring to FIG. 4A, the spare area 2 having the size of $4N$ is allocated to the end of the data area 0 during initialization of the write-once disc. Here, the size of an area refers to the number of error correction code (ECC) blocks or the amount of data that can be recorded in the area. In the present embodiment, the size of a specific area refers to the number of ECC blocks of the specific area. Here, $4L$ indicates the maximum size allocable to the spare area 2.
- [40] Referring to FIG. 4B, the spare area 2 is divided into the sub spare area 2 and the TDMA 2. The data area 0 is used from the inside out, while the sub spare area 2 is used from the outside in so as to be easily extended.
- [41] As previously described, the amount of data recorded in a spare area is proportional to the amount of data recorded in a TDMA. Thus, it is preferable that the size of the spare area is determined according to the size of the TDMA. In the present embodiment, as shown in FIG. 4B, the TDMA 2 has the size of K which is greater than or equal to N or less than or equal to L . In other words, the size of the TDMA 2 is greater than or equal to 1/4 of the size of the spare area 2 or less than or equal to 1/4 of the maximum size allocable to the spare area 2. Thus, since the TDMA 2 has the size of K , the spare area 2 has the size of $4N-K$.
- [42] After the spare area 2 is divided into the sub spare area 2 and the TDMA 2, the size of the TDMA 2 cannot vary. However, the sub spare area 2 may be extended inward or reduced outward. The extension of the sub spare area 2 is possible when data is not recorded in user data area 0 adjacent to the sub spare area 2.

- [43] According to the present embodiment, the sub spare area 2 is extended according to the size of the TDMA 2. In other words, the sub spare area 2 is extended so that the sum of the sizes of the extended sub spare area 2 and the TDMA 2 does not exceed four times the size of the TDMA 2. When the size of the TDMA 2 is 1/4 of the size of the spare area 2, i.e., N, the spare area 2 may not be extended.
- [44] If the amount of data to be recorded in a spare area is small but a user data area must be extended, the sub spare area 2 may be reduced. Here, the size of the spare area 2 is reduced to '0'.
- [45] FIGS. 5A and 5B are views showing the structure of recording layer L1 of a dual recording layer write-once disc in which spare areas and a TDMA are allocated to a data area, according to an embodiment of the present invention.
- [46] In the case of the dual recording layer write-once disc according to the present embodiment, spare areas 1 and 2 may be allocated to recording layer L0, and spare areas 3 and 4 may be allocated to recording layer L1. Here, it is preferable that the spare area 4 is divided into sub spare area 4 and TDMA 2. All spare areas may be extended or reduced during the use of the write-once disc. However, the spare area 4 is most easily extended. Thus, in the present embodiment, the spare area 4 is divided into the sub spare area 4 and the TDMA 2. Here, like the case of the recording layer L0 of FIGS. 4A and 4B, the ratio of the size of the spare area 4 to the size of the TDMA 2 is 4:1.
- [47] The size range of the TDMA 2 in the spare area 4 and the range of extension or reduction of the sub spare area 4 are the same as in the embodiment of FIGS. 4A and 4B. However, the present embodiment is different from the embodiment of FIGS. 4A and 4B in that the spare area 4 is divided into the sub spare area 4 and the TDMA 2, user data area 1 is used from the outside in, and the spare area 4 is used from the inside out.
- [48] FIG. 6 is a block diagram of a data recording and/or reproducing apparatus, according to an embodiment of the present invention. Referring to FIG. 6, the data recording and/or reproducing apparatus includes a recording and/or reading unit 1, a controller 2, and a memory 3. Here, a write-once disc 100 may be the single recording layer write-once disc of FIG. 1A or the dual recording layer write-once disc of FIG. 1B.
- [49] The recording and/or reading unit 1 records data on and/or reproduces data from the write-once disc 100 under the control of the controller 2. Data to be recorded on the write-once disc 100 includes user data, a **TDFL**, a **TDDS**, and so on. The

TDDS includes information as to whether a spare area is allocated to a data area of the write-once disc 100, information as to the position and size of the spare area, and information as to the position and size of a sub spare area and a TDMA into which the spare area is divided.

- [50] The controller 2 controls the overall operation of the data recording and/or reproducing apparatus according to the present embodiment. In particular, the controller 2 allocates the spare area to the data area of the write-once disc 100 or divides the spare area into the sub spare area and the TDMA and records information on the allocation of the spare area to the data area on the write-once disc 100.
- [51] The memory 3 temporarily stores data read from the write-once disc 100 or various kinds of data to be recorded on the write-once disc 100.
- [52] A method of using a write-once disc adopting the data recording and/or reproducing apparatus of FIG. 6, according to an embodiment of the present invention, will now be explained.
- [53] FIG. 7 is a flowchart of a method of using a single recording layer write-once disc, according to an embodiment of the present invention.
- [54] Here, the method will be explained in detail with reference to the write-once disc of FIGS. 4A and 4B.
- [55] In step 11, the controller 2 allocates an area, which ranges from a predetermined position of a data area of a recording layer of a single recording layer write-once disc to the last position of the data area, as a spare area according to the command of a user or a program. In the case of the write-once disc according to the embodiment of FIG. 4A, the spare areas 1 and 2 have been allocated to both ends of the data area 0. However, the spare area 2 allocated to the outside of the data area 0 is the main area of the present invention. The allocation of the spare area is performed before user data is recorded, i.e., when the write-once disc 100 is initialized.
- [56] When the spare area is allocated to the data area, the controller 2 controls the recording and/or reading unit 1 to record information for indicating that the spare area has been allocated to the data area and information as to the position and size of the spare area in a predetermined area of the write-once disc 100, for example, in a TDMA.
- [57] In step 13, the controller 2 divides the spare area 2 into sub spare area 2 and TDMA 2 from the inside out according to the command of the user or a program. If user data is recorded in the data area from the inside out, the spare area 2 is divided into the sub spare area 2 and the TDMA 2 from the inside out, because adjoining the

outer edge of a user data area with the sub spare area 2 allows the sub spare area 2 to be easily extended or reduced. In step 13, it is preferable that the size of the TDMA 2 is greater than or equal to $1/N$ (N is a real number) of the size of the spare area 2. Also, it is preferable that the size of the TDMA 2 is less than or equal to $1/N$ of the maximum size allocable to the sub spare area 2. In the present embodiment, N is 4.

[58] Steps 11 and 13 are performed during initialization of the write-once disc 100. Since the user data is recorded on the write-once disc 100 after the write-once disc 100 is initialized, data is recorded in each of at least one spare area and at least one TDMA of the write-once disc 100.

[59] If a spare area is needed when the spare areas 1 and 2 of the write-once disc 100 are almost full during the use of the write-once disc 100, in step 15, the controller 2 extends the sub spare area 2 to be less than N times the size of the TDMA 2 toward the inner edge of the sub spare area 2 according to the command of the user or a program. Alternatively, if the user data area is to be extended due to the user data area filling up, in step 15, the controller 2 reduces the size of the sub spare area 2. When the size of the sub spare area 2 is adjusted, the controller 2 controls the recording and/or reading unit 1 to record information on the adjusted position and/or size of the sub spare area 2 in a predetermined area of the write-once disc 100, for example, in a TDMA.

[60] The method of using the write-once disc and the data recording and/or reproducing apparatus, according to the present invention, have been described with reference to the single recording layer write-once disc of FIGS. 4A and 4B, but may also be applied to a dual recording layer write-once disc. In other words, as shown in FIGS. 5A and 5B, the spare area 4 of the recording layer L1 of the dual recording layer write-once disc may be divided into the TDMA 2 and the sub spare area 4, and then the sub spare area 4 may be extended or reduced as in the case of the above-described single recording layer write-once disc.

[61] While the present invention has been particularly shown and described with reference to exemplary embodiments thereof, it will be understood by those of ordinary skill in the art that various changes in form and details may be made therein without departing from the spirit and scope of the present invention as defined by the following claims.

Claims:

1. A method of using a write-once disc comprising at least one recording layer, the method comprising:

allocating at least one spare area to a data area of the at least one recording layer; and

dividing the at least one spare area into a sub spare area and a temporary disc management area,

wherein the size of the temporary disc management area is greater than or equal to $1/N$ (N is a real number) of the size of the spare area, and

wherein user data area which is included in the data area and the sub spare area are used in the opposite direction.
2. The method of claim 1, wherein the size of the temporary disc Management area is less than or equal to $1/N$ of the maximum size allocable to the spare area.
3. The method of claim 1, further comprising:

extending the sub spare area in the direction opposite to that in which the user data is recorded, to be less than or equal to N times the size of the temporary disc management area.
4. The method of claim 1, further comprising:

reducing the sub spare area in the direction in which the user data is recorded.
5. The method of claim 1, wherein each spare area is an area in which the user data is re-recorded or updated file system information is recorded when the user data recorded in a user data area has a defect.
6. The method of claim 1, wherein the temporary disc management area is an area in which a temporary disc definition structure is recorded.
7. The method of claim 1, wherein N is 4.
8. A data recording and/or reproducing apparatus comprising:

a recording and/or reading unit which records data on and/or reads data from a write-once disc comprising at least one recording layer; and

a controller which allocates at least one spare area to a data area of the at least one recording layer, divides the at least one spare area into a sub spare area and a temporary disc management area, and controls the recording and/or reading unit to record information on position and/or size of each spare area and information on position and/or size of the sub spare area and the temporary disc management area on the write-once disc, wherein the controller determines the size of the temporary disc management area to be greater than or equal to $1/N$ of the size of one spare area, and wherein user data area which is included in the data area and the sub spare area are used in the opposite direction.

9. The data recording and/or reproducing apparatus of claim 8, wherein the controller determines the size of the temporary disc management area to be less than or equal to $1/N$ of the maximum size allocable to one spare area.

10. The data recording and/or reproducing apparatus of claim 8, wherein the controller extends the sub spare area in the direction opposite to that in which the user data is recorded, to be less than or equal to N times of the size of the temporary disc management area, and controls the recording and/or reading unit to record information on the size of the extended sub spare area on the write-once disc.

11. The data recording and/or reproducing apparatus of claim 8, wherein the controller reduces the sub spare area in the direction in which the user data is recorded, and controls the recording and/or reading unit to record information on the size of the reduced sub spare area on the write-once disc.

12. The data recording and/or reproducing apparatus of claim 8, wherein each spare area is an area in which the user data is re-recorded or updated file system information is recorded when the user data recorded in a user data area has a defect.

13. The data recording and/or reproducing apparatus of claim 8, wherein the temporary disc management area is an area in which a temporary disc definition structure is recorded.

14. The data recording and/or reproducing apparatus of claim 8, wherein N is 4.

15. A single recording layer write-once disc on which user data is recorded from the inside out, comprising:

a recording layer which comprises a data area, wherein the data area comprises:
a spare area which is allocated to an area ranging from a predetermined position of the data area to the last position of the data area and which is divided into a sub spare area and a temporary disc management area from the inside out, wherein the size of the temporary disc management area is greater than or equal to $1/N$ (N is a real number) of the size of the spare area, and wherein user data area which is included in the data area and the sub spare area are used in the opposite direction.

16. The single recording layer write-once disc of claim 15, wherein the size of the temporary disc management area is less than or equal to $1/N$ of the maximum size allocable to the spare area.

17. The single recording layer write-once disc of claim 15, wherein the sub spare area is an area which is extended inward to be less than or equal to N times the size of the temporary disc management area.

18. The single recording layer write-once disc of claim 15, wherein the sub spare area is an area which is reduced outward.

19. The single recording layer write-once disc of claim 15, wherein the spare area is an area in which the user data is re-recorded or updated file system information is recorded when the user data recorded in a user data area has a defect.

20. The single recording layer write-once disc of claim 15, wherein the temporary disc management area is an area in which a temporary disc definition structure is recorded.

21. The single recording layer write-once disc of claim 15, wherein N is 4.

22. A dual recording layer write-once disc comprising:

a first recording layer on which user data is recorded using an opposite track path method; and

a second recording layer which comprises a data area, wherein an area ranging from a predetermined position of the data area to the last position of the data area is allocated as a spare area which is divided into a sub spare area and a temporary disc management area from the outside in, and the size of the temporary disc management area is greater than or equal to $1/N$ (N is a real number) of the size of the spare area.

23. The dual recording layer write-once disc of claim 22, wherein the size of the temporary disc management area is less than or equal to $1/N$ of the maximum size allocable to the spare area.
24. The dual recording layer write-once disc of claim 22, wherein the sub spare area is an area which is extended outward to be less than or equal to N times the size of the temporary disc management area.
25. The dual recording layer write-once disc of claim 22, wherein the sub spare area is an area which is reduced inward.
26. The dual recording layer write-once disc of claim 22, wherein the spare area is an area in which the user data is re-recorded or updated file system information is recorded when the user data recorded in a user data area has a defect.
27. The dual recording layer write-once disc of claim 22, wherein the temporary disc management area is an area in which a temporary disc definition structure is recorded.
28. The dual recording layer write-once disc of claim 22, wherein N is 4.

FIG. 1A

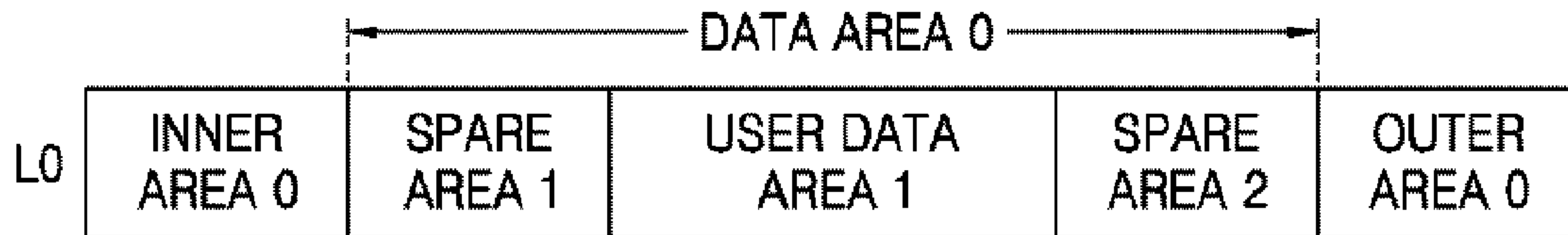

FIG. 1B

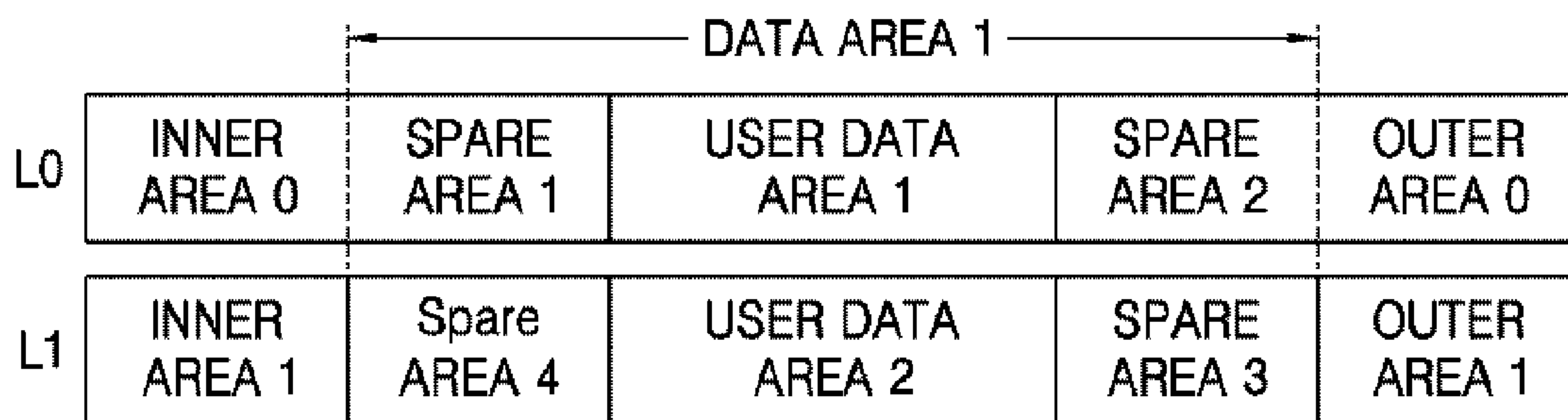

FIG. 2

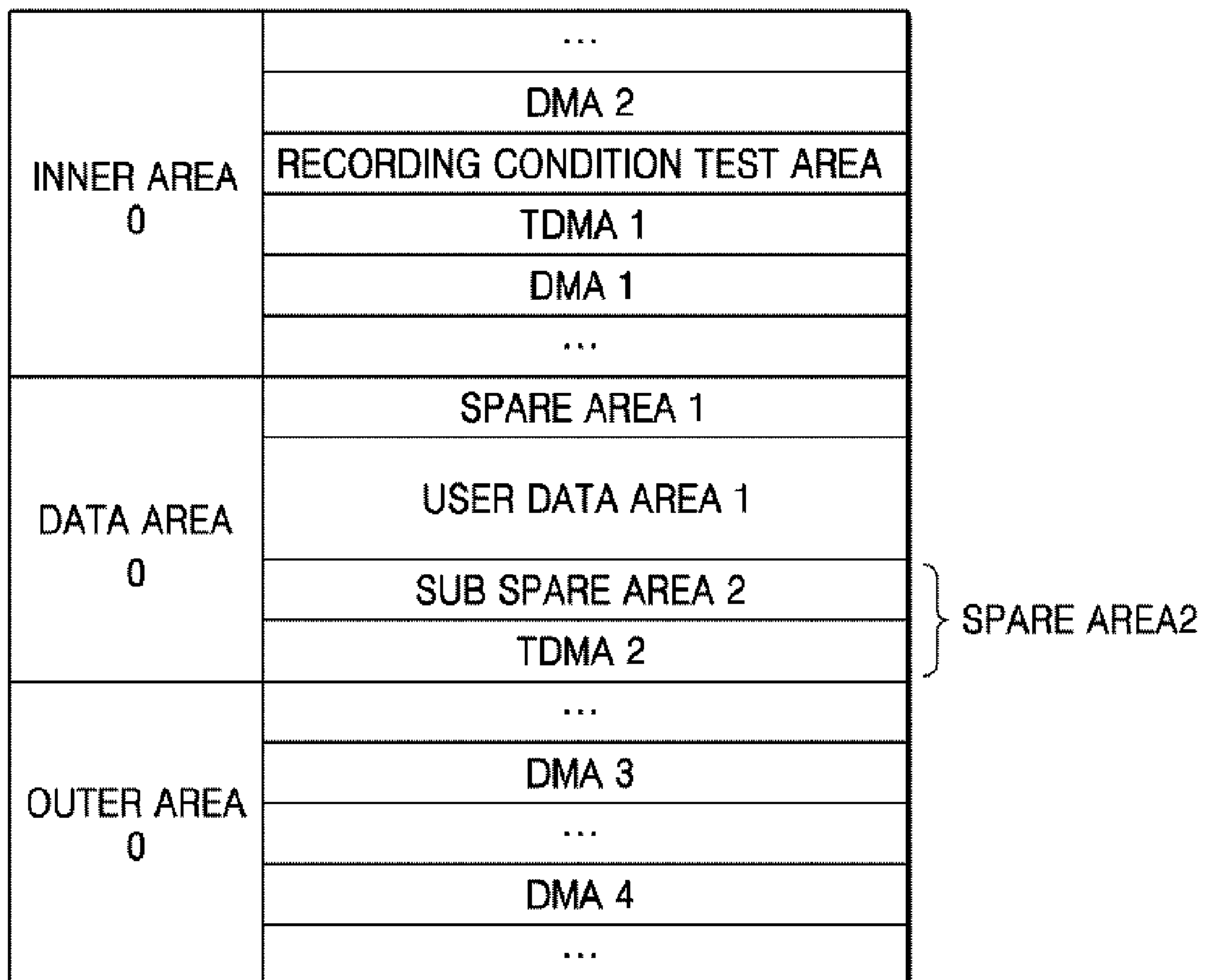

FIG. 3A

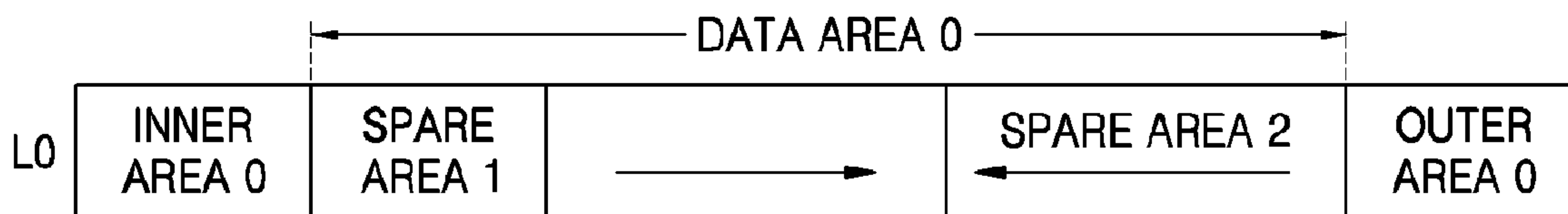

FIG. 3B

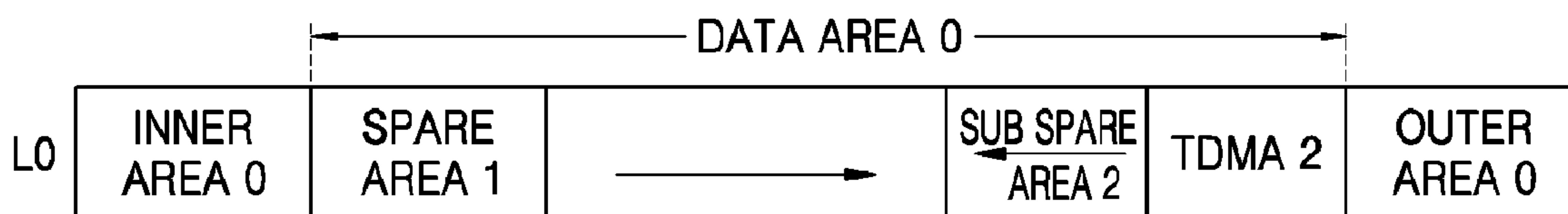

FIG. 4A

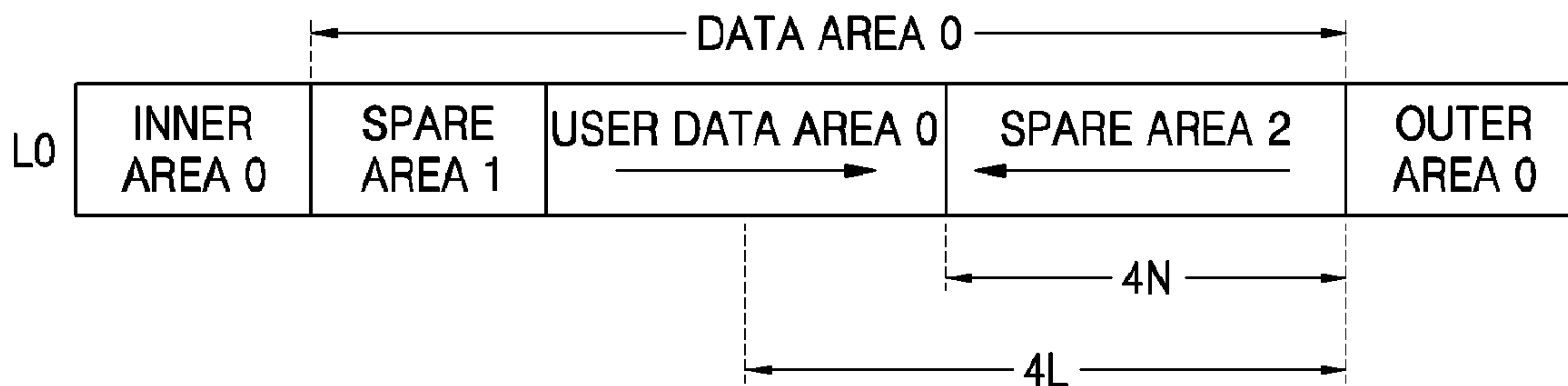

FIG. 4B

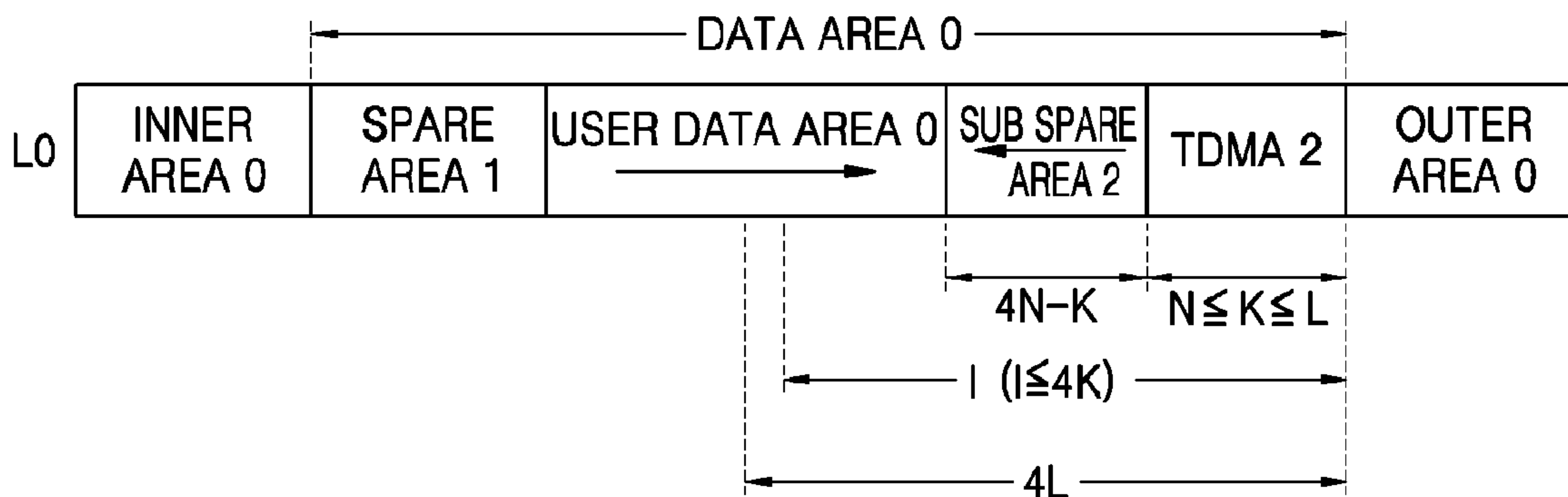

FIG. 5A

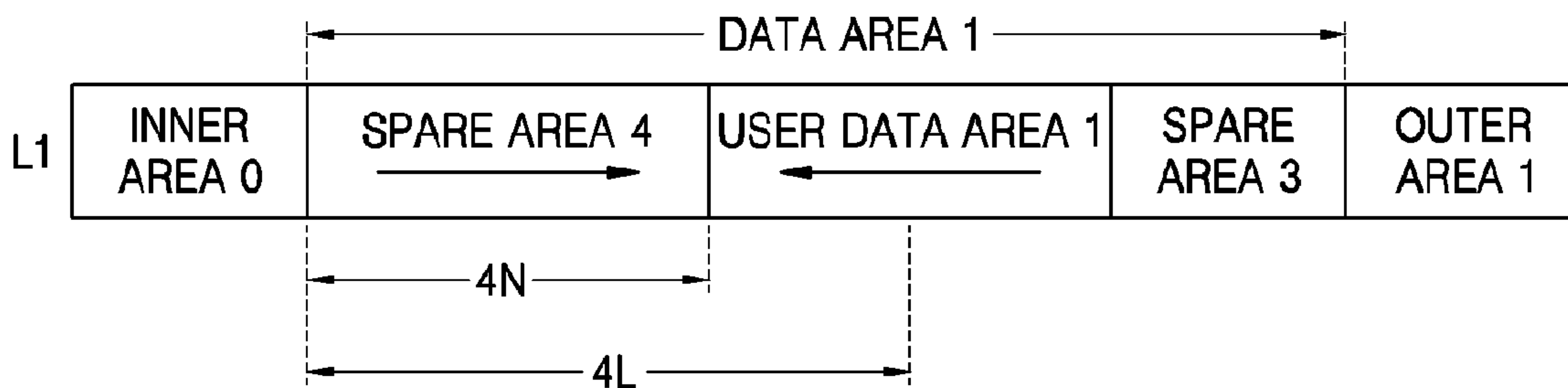

FIG. 5B

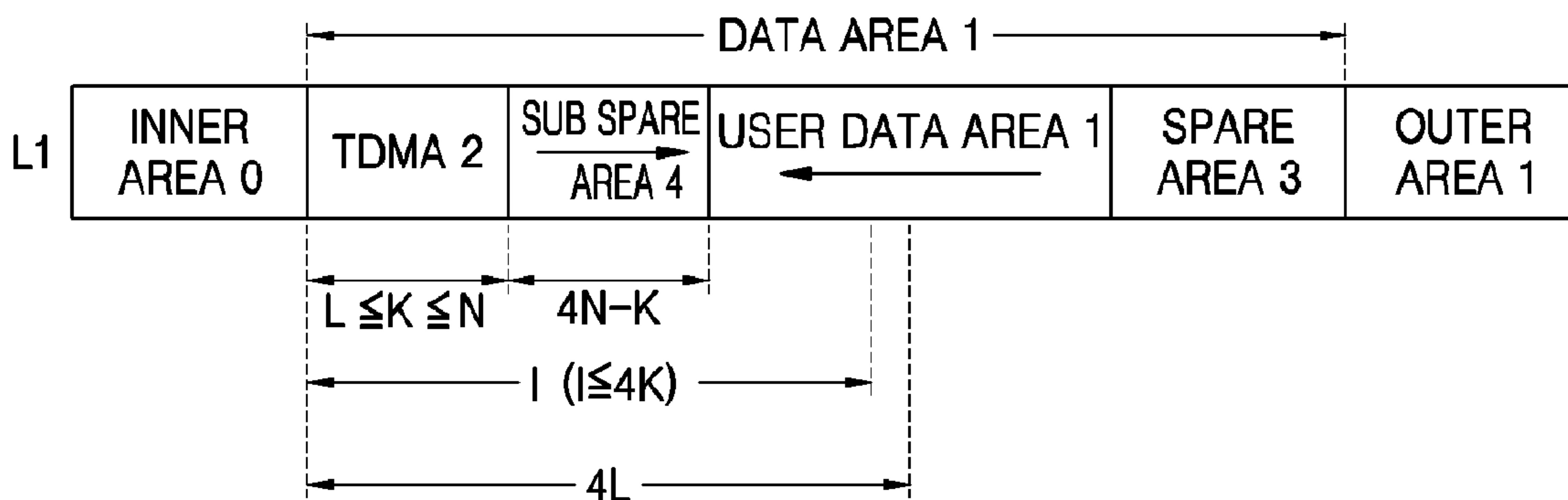

FIG. 6

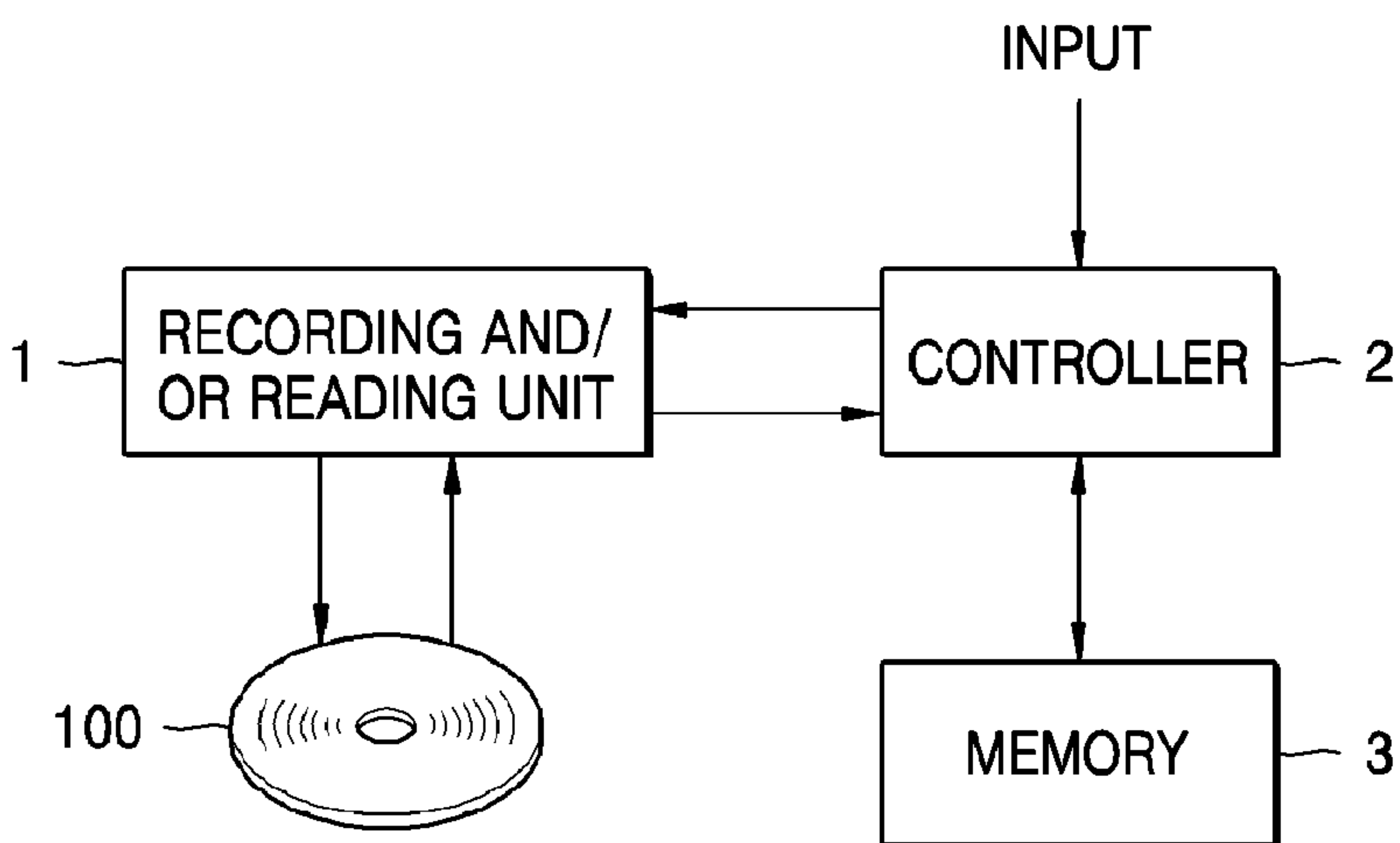
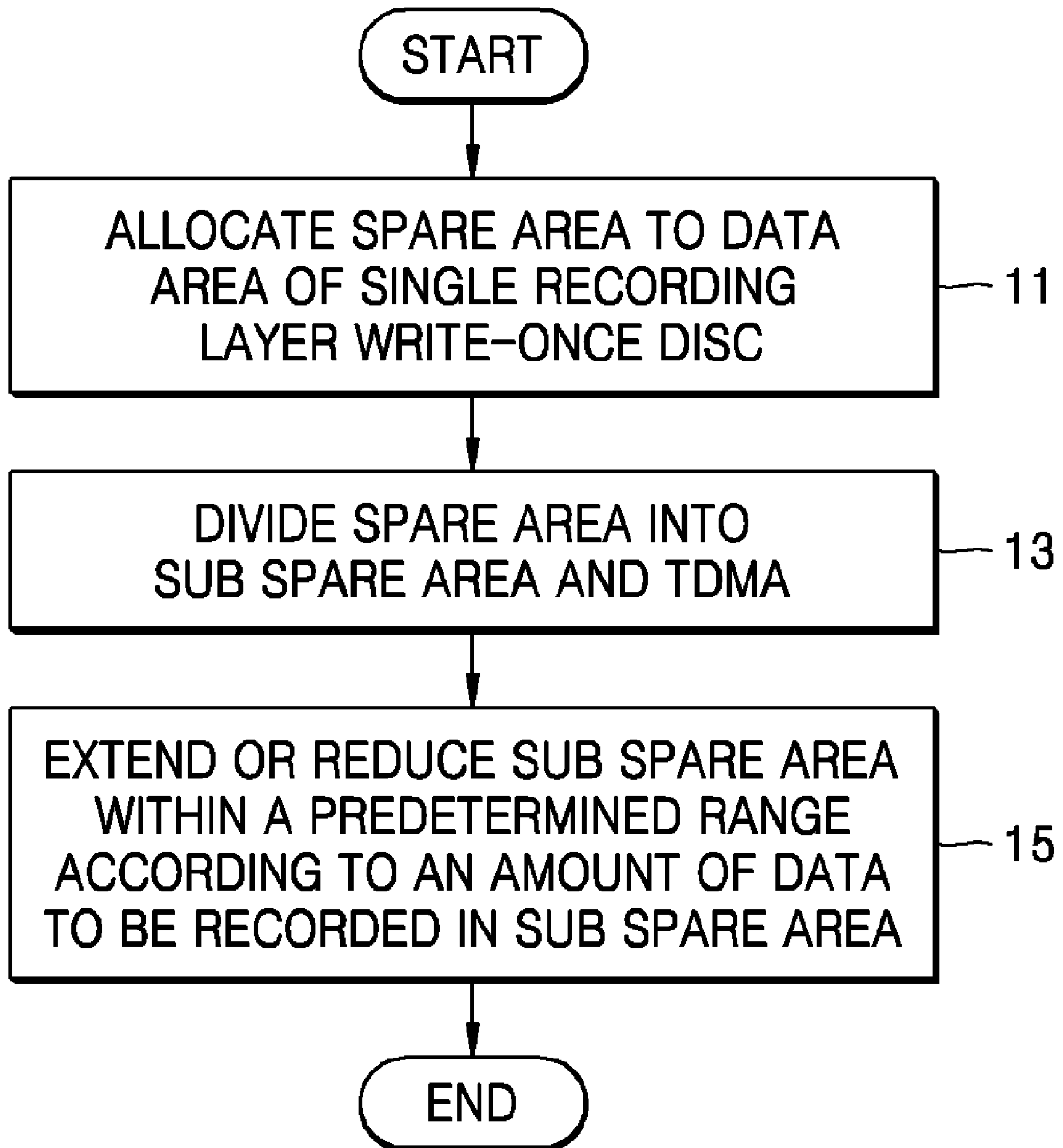

FIG. 7



START

ALLOCATE SPARE AREA TO DATA
AREA OF SINGLE RECORDING
LAYER WRITE-ONCE DISC

11

DIVIDE SPARE AREA INTO
SUB SPARE AREA AND TDMA

13

EXTEND OR REDUCE SUB SPARE AREA
WITHIN A PREDETERMINED RANGE
ACCORDING TO AN AMOUNT OF DATA
TO BE RECORDED IN SUB SPARE AREA

15

END